

COMBINATION CASES

- CONVERTIBLE SERVICE ABOVE REFRIGERATED SELF-SERVICE (HOU[L*]52R)
- NON-REFRIGERATED SERVICE ABOVE REFRIGERATED SELF-SERVICE (HUDLR[L*]52)
- REFRIGERATED SERVICE ABOVE REFRIGERATED SELF-SERVICE (HURLR[L*]52)
- NON-REFRIGERATED SERVICE BESIDE REFRIGERATED SELF-SERVICE (HVLD[L*]RSS)
- REFRIGERATED SERVICE BESIDE NON-REFRIGERATED SERVICE (H5C[L*]50LR or RR)
- NON-REFRIGERATED SERVICE ABOVE REFRIGERATED SERVICE (HSL[L*]50R)
- REFRIGERATED SERVICE ABOVE REFRIGERATED SELF-SERVICE WITH REAR STORAGE (HVOU[L*]RSS)

PLEASE NOTE THE FOLLOWING:

1. YOUR SPECIFIC MODEL NUMBER IS ON THE SERIAL LABEL ON CASE REAR (NEAR MAIN POWER SWITCH).
2. CASES SHOWN REFLECT FULL & OPEN END PANELS / STRAIGHT OR ANGLED BASES. YOURS MAY DIFFER.
3. SEE "MODELS (AND THEIR RESPECTIVE CASE DIMENSIONS) LISTED IN THIS MANUAL" SECTION FOR ADDITIONAL INFORMATION REGARDING SPECIFIC CASE DIMENSIONS OF STANDARD MODELS AND CDRs.
4. *[L] DENOTES VARIETY OF CASE LENGTHS.

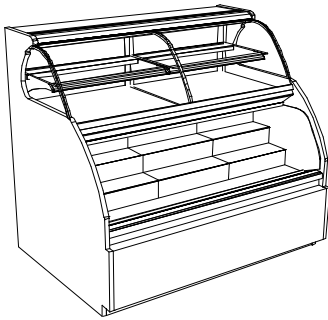

HOU[L*]52R w/Optional Lower Display Steps

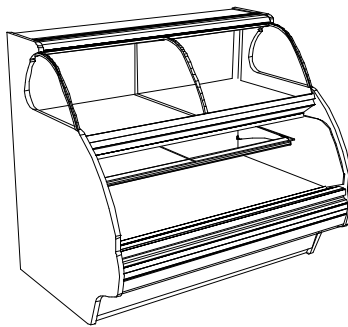

HOU[L*]52R Optional Angled Base

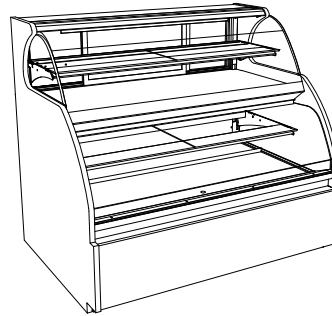

HUDLR[L*]52 Straight Base

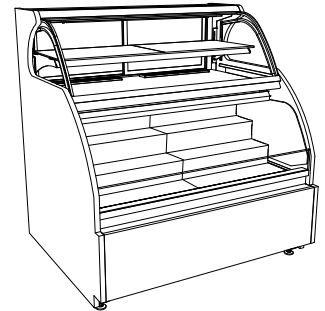

HURLR[L*]52 w/Optional Lower Display Steps

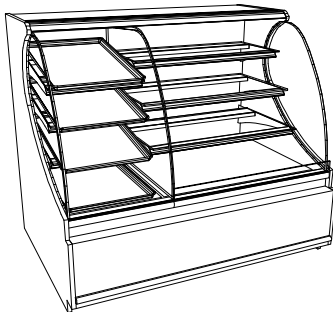

HVLD[L*]RSS With Straight Base

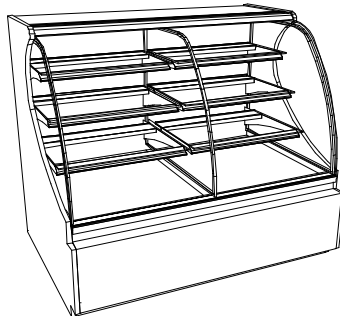

H5C[L*]50LR or RR Straight Base / Cutaway Ends

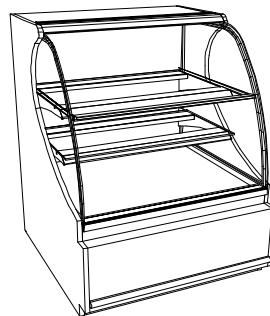

HSL[L*]50R Optional Lower Shelf

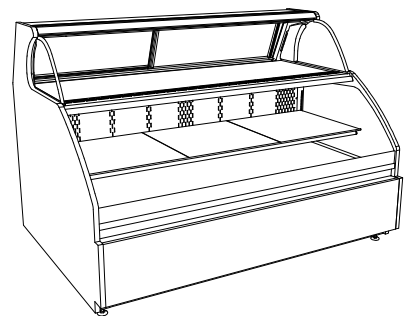

HVOU[L*]RSS Straight Base

TABLE OF CONTENTS

TABLE OF CONTENTS	2
MODELS LISTED IN MANUAL / DETERMINING THEIR RESPECTIVE CASE DIMENSIONS.....	3
OVERVIEW / TYPE / COMPLIANCE / WARNINGS / PRECAUTIONS / WIRING / PLUGS.....	4-5
INSTALLATION: REMOVAL FROM SKID, REMOVING LOWER FRONT PANELS	6
INSTALLATION: ADJUSTING FRONT PANELS / ADJOINING UNITS / GLASS SHELVING	7
INSTALLATION: ELEC. CONNECTIONS / LOCKING CASTERS / ADJUSTING LEVELERS	8
INSTALLATION: FRONT GLASS ALIGNMENT & ADJUSTMENT (CURVED & FLAT)	9
INSTALLATION: REFRIG. LINES / STUB-UPS / DRAINS / WIRING DIAGRAMS / VENTILATION	10
INSTALLATION: DISPLAY CASE START-UP / REAR STORAGE (MODEL HVOU[L]RSS ONLY)	11
INSTALLATION: DISPLAY CASE START-UP, LIGHTS, TEMPERATURE CONTROLLER, SST	12
BAFFLES: AMBIENT VS. REFRIGERATED CONDITIONS	13
OPTIONAL NIGHT AIR CURTAIN INST. / OPER. INSTRUCTIONS (HUDLR / HURLR / HOU)	14
OPTIONAL NIGHT AIR CURTAIN INST. & OPERATING INSTRUCTIONS (MODEL HVLD[L]RSS).....	15
SECURITY GRID INSTRUCTIONS (OPTIONAL)	16-17
SECURITY GRID INFORMATION FOR MODEL HVLD[L]RSS ONLY.....	18
DRAIN, HOSE AND BRACKET PLACEMENT ILLUSTRATIONS	19
MAINTENANCE FUNDAMENTALS - STANDARD LIGHT FIXTURES / REAR SLIDING DOORS.....	20
MAINTENANCE FUNDAMENTALS - LED LIGHTS/BRACKETS/SHELVES/DRAIN/TXV VALVE	21
MAINTENANCE FUNDAMENTALS - REFRIG. PKG., TEMP. CONTROLLER, EVAPORATOR PAN	22
MAINTENANCE FUNDAMENTALS - ENERGYWISE REFRIGERATION PACKAGE LAYOUT	23
MAINTENANCE FUNDAMENTALS - HONEYCOMB AIR DIFFUSERS/UPPER SECT'N AIR DUCT	24
CLEANING SCHEDULE	25
TROUBLESHOOTING - GENERAL ISSUES	26-28
TROUBLESHOOTING - CONDENSING SYSTEM	29
TROUBLESHOOTING - EVAPORATOR SYSTEM	30
PREVENTIVE MAINTENANCE (TO BE PERFORMED BY TRAINED SERVICE PROVIDER)	31-32
SERIAL LABEL INFORMATION & LOCATION	33
TEMPERATURE CONTROLLER - CAREL®	34-33
TEMPERATURE CONTROLLER - CPC®	37-38
TECHNICAL SERVICE CONTACT INFORMATION & WARRANTY INFORMATION	39

DETERMINING YOUR MODEL AND ITS CASE DIMENSIONS:

Note 1. Your model number can be found on serial label at rear of case (near main power switch).

Note 2. Dimensions of most models can be found at www.structuralconcepts.com. Simply enter the case model number into the Product Number Search box. Click the ***product specification*** link for complete dimensions.

Note 3. If your specific model is not found, contact technical service (phone number is listed at Technical Service section in this manual) for dimensions.

Note 4. CDRs (Customer Design Requests) are listed with a 4-digit number. All CDR dimensions are identical to standard model dimensions.

NOTE: THIS OPERATING MANUAL ENCOMPASSES THE FOLLOWING (AND POSSIBLY OTHER) STRUCTURAL CONCEPTS MODELS:

***Standard HOU3852R HOU3852R.4758 HOU3852R.5149 HOU4852R HOU5652R
HOU7452R HOU9652R HOU9652R.4419 HOU9652R.4419A HOU11252R.4419C
H5C4850LR H5C4850RR H5C5650LR H5C5650RR H5C7450LR H5C7450RR
HSL3850R HSL4850R HUDLR3852 HUDLR3852.5520 HUDLR4852 HUDLR5652
HUDLR7452 HVLD48RSS HVLD56RSS HVLD74RSS HVOU56RSS HVOU74RSS
HVOU96RSS HVOU144RSS HVOU96RSS.3580B HVOU96RSS.3615A
HVOU96RSS.4260 HVOU144RSS.3580C HVOU96RSS.3580D HVOU144RSS.3580E
HVOU144RSS.4261 HVLD48RSS HVLD56RSS HVLD74RSS***

OVERVIEW

- These Structural Concepts merchandisers are designed to merchandise packaged products at 41 °F [5 °C] or less product temperatures [unless custom cases with wire rack shelving].
- Cases should be installed and operated according to this operating manual's instructions to ensure proper performance.
- Improper use will void warranty.

CASE TYPE

This unit is designed for the display of products in ambient store conditions where temperatures and humidity are maintained within a specific range.

- For Type 1 Conditions (most cases): ambient conditions are to be at 55% maximum humidity and maximum temperatures of 75 °F [24 °C].
- For Type 2 Conditions: ambient conditions are to be at 60% maximum humidity and maximum temperatures of 80 °F [27 °C].

- If unsure if unit is designed for Type 1 or 2, see tag next to serial label. See **SERIAL LABEL LOCATION & INFORMATION LISTED / TECH INFO & SERVICE** section in this manual for sample serial labels.

COMPLIANCE

- Performance issues when in violation of applicable NEC, federal, state and local electrical and plumbing codes are not covered by warranty.
- See below compliance guideline.

WARNINGS

- This sheet contains important warnings to prevent injury or death.
- Please read carefully!

PRECAUTIONS, CORD/PLUG MAINTENANCE & WIRING DIAGRAM INFORMATION

- See next page for **PRECAUTIONS, CORD/PLUG MAINTENANCE** and **WIRING DIAGRAM** information.



**ATTENTION
INSTALLER**

COMPLIANCE
This equipment **MUST** be installed in compliance with all applicable NEC, federal, state and local electrical and plumbing codes.



WARNING
Risk of electric shock. Disconnect power before servicing unit. **CAUTION!** More than one source of electrical supply is employed with units that have separate circuits. **Disconnect ALL ELECTRICAL SOURCES before servicing.**



WARNING
Hazardous moving parts. Do not operate unit with covers removed. Fan blades may be exposed when deck panel is removed. Disconnect power before removing deck panel.



WARNING
Condensate Pan is Hot!
Disconnect and allow to cool before cleaning or removing from case.

PRECAUTIONS

- This sheet contains important precautions to prevent damage to unit or merchandise.
- Please read carefully!
- See previous page for specifics on **OVERVIEW**, **TYPE**, **COMPLIANCE** and **WARNINGS**.

WIRING DIAGRAM

- Each case has its own wiring diagram folded and in its own packet.
- Wiring diagram placement may vary; it may be placed near ballast box, field wiring box, raceway cover, or other related location.

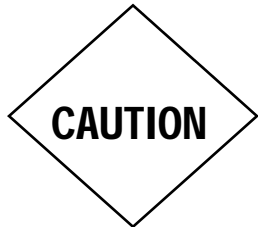

CAUTION! LAMP REPLACEMENT GUIDELINES
 LED lamps reflect specific size, shape and overall design. Any replacements must meet factory specifications. Fluorescent lamps have been treated to resist breakage and must be replaced with similarly treated lamps.



CAUTION! GFCI BREAKER USE RECOMMENDATION
 If N.E.C. (National Electric Code) or your local code requires GFCI (Ground Fault Circuit Interrupter) protection, the use of a GFCI breaker is strongly recommended.



CAUTION! POWER CORD AND PLUG MAINTENANCE
 Risk of electric shock. If cord or plug becomes damaged, replace only with cord and plug of same type.

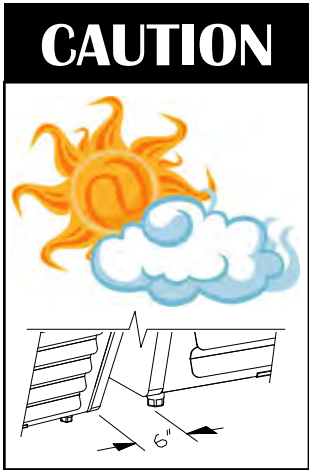

CAUTION! ADVERSE CONDITIONS / SPACING ISSUES

- Performance issues caused by adverse conditions are NOT warranted.
- End panels must be tightly joined or kept at least 6-inches away from any structure to prevent condensation.
- Unit must be kept at least 15-feet from exterior doors, overhead HVAC vents or any air curtain disruption to maintain proper temperatures.
- Unit must not be exposed to direct sunlight or any heat source (ovens, fryers, etc.).
- Tile floors, low ceilings or small rooms increase noise level. Whisper Cool compressor blankets or remote units resolve noise level issues.
- Keep at least 8-inch clearance above unit for air discharge (self-contained units only).

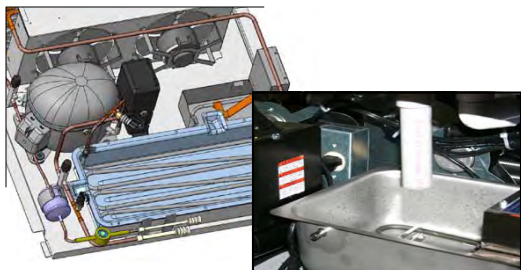

CAUTION! CHECK CONDENSATE PAN POSITION & PLUG
 Water on flooring can cause extensive damage!
 Before powering up unit, check that:

- Condensate pan is **DIRECTLY UNDER** condensate drain.
- Condensate pan plug is securely plugged into receptacle.

INSTALLATION: REMOVAL FROM SKID, REMOVING LOWER FRONT PANELS

1. Remove Case From Skid (Levelers)

- Remove shipping brace that may be securing case to skid.
- Support case to prevent tipping.
- **Caution! Levelers can be damaged if case hits floor with heavy force!**
- Carefully slide unit to rear of skid and tip backward off skid.
- Illustration may not reflect every feature or option of your particular case.

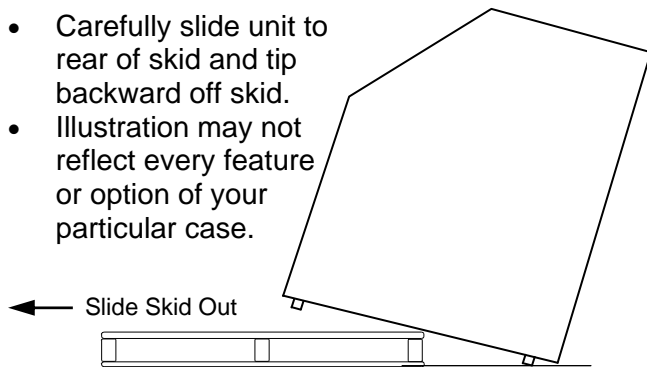

Case can be repositioned with pallet truck when front lower panel is removed. Blocking may be necessary to obtain adequate height.

2. Remove Case From Skid (Casters)

- Remove shipping brackets that may be securing casters to skid
- Place ramp up against skid (to allow case to smoothly slide off from skid).
 - Maintain support of case at all times or center of gravity may cause case to fall.
 - Unlock Casters. Roll unit to rear of skid.

Roll down ramp and off from skid.

Note: Illustrations shown reflect a general outline of sample cases and do not reflect features or options of your particular model.

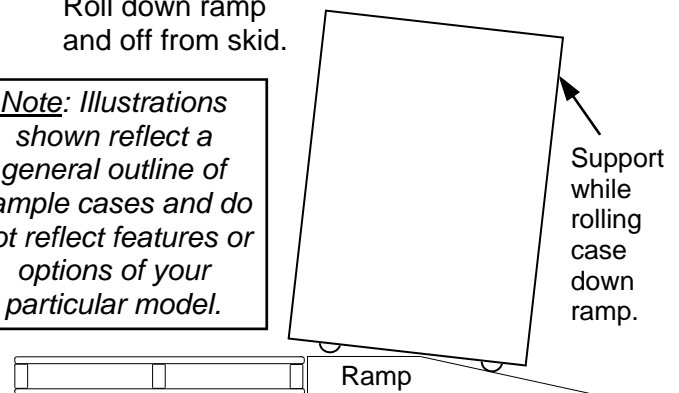

3A. Removing Angled Lower Front Panels

Upper panel support.

- Remove screws located behind upper front panel.

Lower panel support.

- *Most applications*, screws secure the lower panel support (located below front panel) to the unit.

See illustration at right.

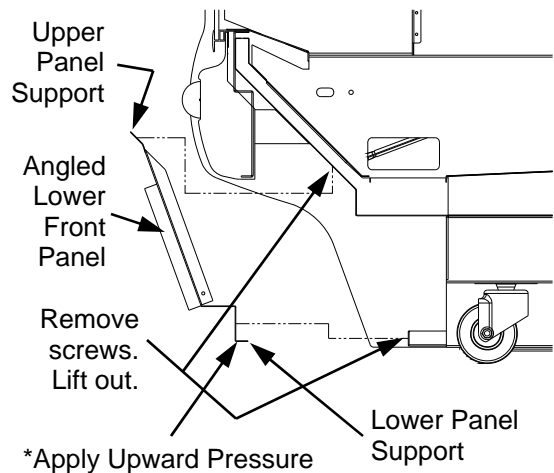

3B. Removing Vertical Lower Front Panels

Front Panel Upper Support

- Lift Front Glass.
- Remove the caps and screws holding Deck Support in place.

Front Panel Lower Support

- For most display cases, screws secure Front Panel Lower Support to Base.
- Remove screws holding Front Panel Lower Support to Display Case Base.

Vertical Lower Front Panel can now be removed (see illustration at lower right).

**Alternate applications (for cases without lower panel screws):* Apply upward pressure to lower panel support to disengage lower support panel tabs from slots located in the base at both ends of the unit.

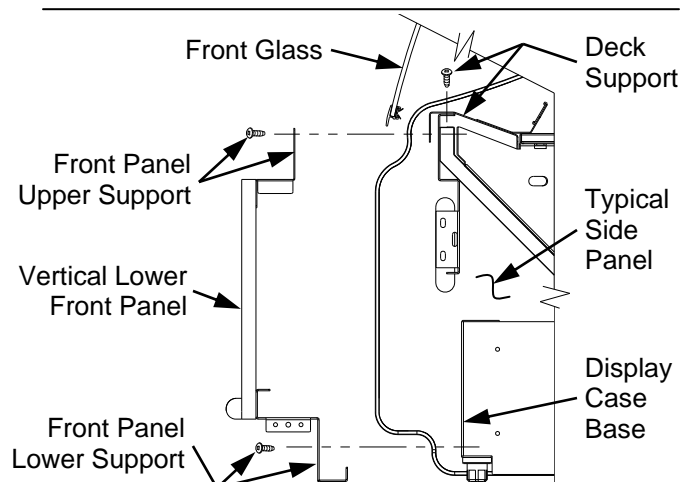

INSTALLATION: ADJUSTING FRONT PANELS / ADJOINING UNITS / GLASS SHELVING

4. Adjusting Upper Front Panels

- Remove screw cover and loosen adjustment screws.
- Adjust alignment and tighten screws.
- See illustration at mid-right.

5. Bolting and Caulking Units Together

Follow these steps to assure a secure, level lineup.

- Begin all lineups leveling from highest point of floor.
- After the 'first' case is level, apply industrial grade butyl caulk on non-visible areas (at case end). Use industrial grade silicone sealant on visible areas (at case end).
- Form Two (2) Caulk/Sealant Lines: (Sanitation and Refrigeration). See illustration at mid-right for outline of caulk/sealant lines.
- Line up 'second' case bolt-hole to bolt-hole to 'first' case.
- Using SCC-supplied bolts (found in installation packet), insert bolts in bolt hole locations (shown at right). You may need to remove decking to access lower bolt holes.
- Caution! Front of cases MUST be flush with each other! After leveling, all cases to be same height.
- Using SCC-supplied nuts & bolts, **lightly tighten** each of the 5 to 8 bolts in a cross-wise pattern. Work your way around the pattern, tightening more firmly at each pass. **Do not** firmly tighten one bolt and then start on the next!
- After the cases are bolted together, level the 'second' case. Repeat this process for each case to be adjoined.
- After all lined-up cases are level, seal all seams with industrial grade silicone sealant.

6. Glass Shelving

Glass shelving will be packed separately.

- Caution! Carefully remove from packaging.
- Grasp firmly and carefully install.
- *Caution! Check that plastic edging is intact before placing glass shelving onto brackets!*
- Plastic edging must NOT be removed from glass shelves. Contact Structural Concepts for replacement edging (see **TECHNICAL SERVICE CONTACT INFORMATION** section).
- Check that glass shelving is in proper position before placing product in case.
- See illustration at lower-right.

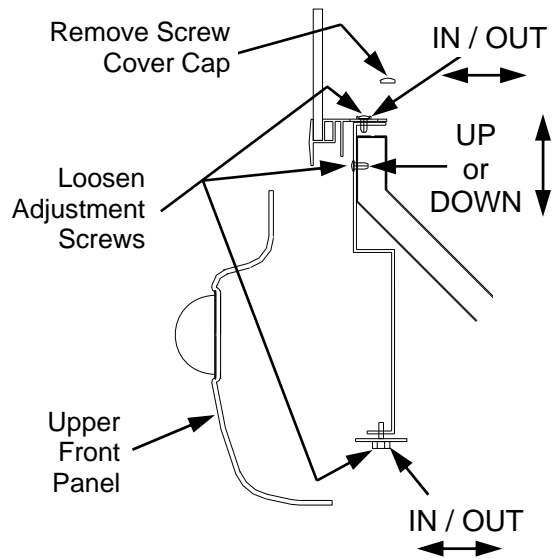

Approximate hole locations pointed at with arrows (←) for bolting units together.

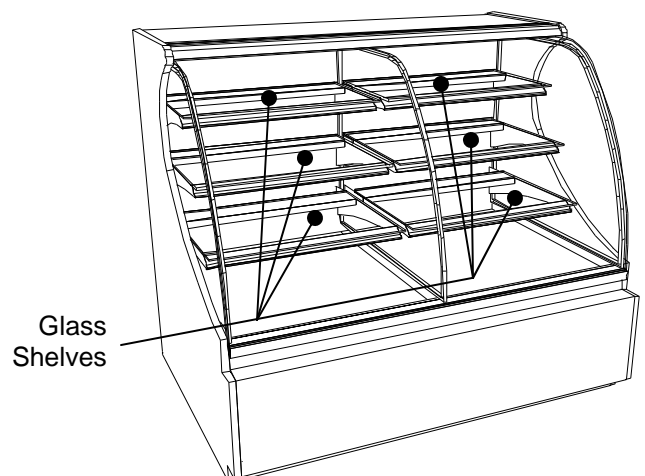
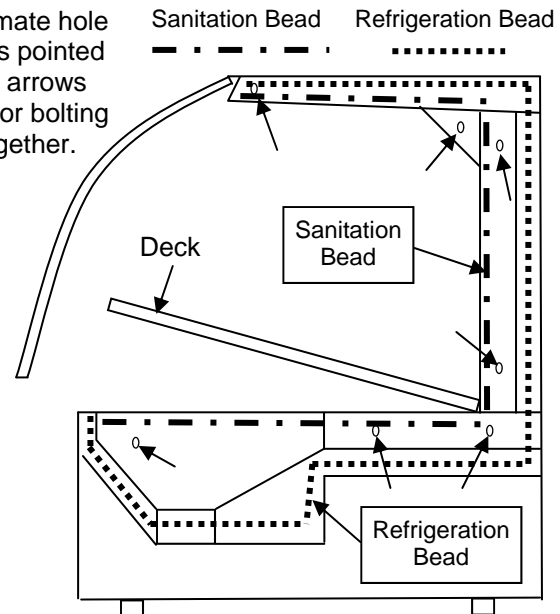

7. Electrical Connections

A. Rear Wire-Ways

- Remove screws from rear wire-way cover to access electrical leads.
- Wiring runs case to case through base cut-outs.
- Knockout is provided in bottom of wire-way for stub-up connection.
- See illustration at top-right.

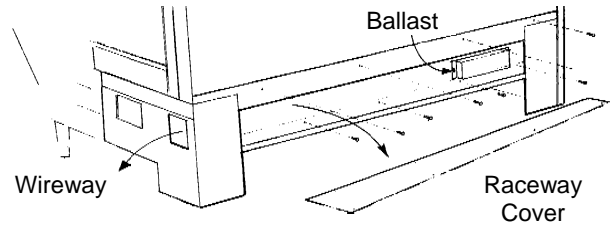

Note: Wiring process must be performed by certified electricians only.

- Voltage rating is on serial label at case rear.

B. Rear Ballast Box

- Remove 4 screws from ballast box face.
- Remove screws from rear panel (if any).
- Remove 3 screws from inner support.
- Knockouts are located on side and rear of box for making electrical connections.

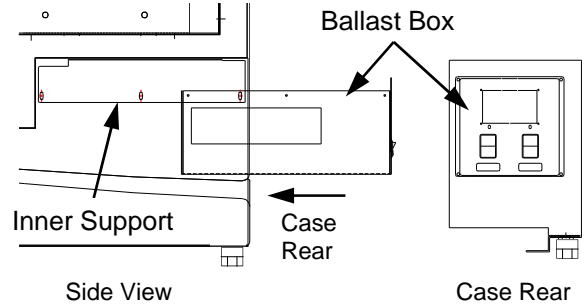

Note: Wiring process must be performed by certified electricians only.

- Serial label (at case rear) lists voltage rating.

C. Front Ballast Box

- Remove front panel.
- Stub-up connections are in ballast box.
- Remove ballast box covers.
- Knockouts are on sides and front of ballast assembly for making electrical connections.

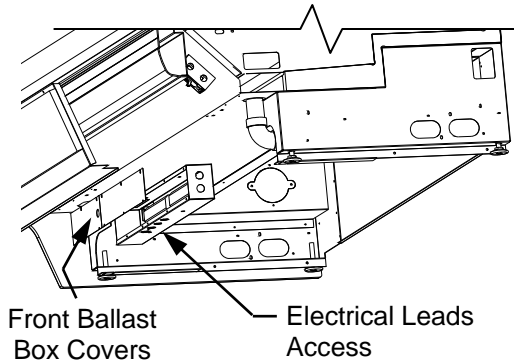

Note: Wiring process must be performed by certified electrician only.

- Voltage rating is on serial label at case rear.

8. Cases With Casters: Lock and Unlock

- To lock casters, press down on lever.
- To unlock casters, pull lever up.
- See illustration at right.

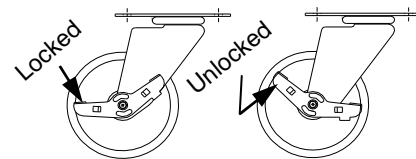

9. Cases With Levelers: Adjust Levelers

- After case is in position, adjust case so it is level and plumb (see illustration at right).
- You may need to remove front and/or rear Toe-Kick to access levelers.
- Use adjustable wrench (and possibly a pry bar) to adjust leveler.
- Do not use pry bar on toe-kick (it may buckle).
- Do not use pry bar on end panel (it may chip).
- Use pry bar ONLY on base frame to avoid damaging case.
- Use a block to reach base frames with pry bar.
- See illustrations at right.

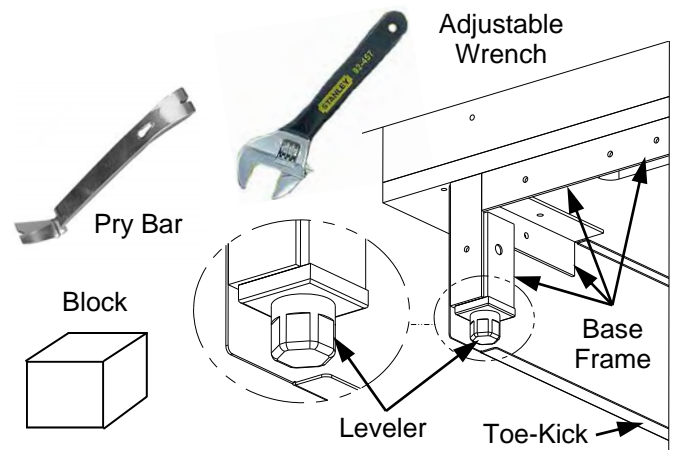

INSTALLATION: FRONT GLASS ALIGNMENT & ADJUSTMENT (CURVED & FLAT FRONT GLASS)

10. Front Glass Alignment & Adjustment via Levelers (For Curved and Flat Front Glass)

- Proper alignment of the front glass is important to create and maintain a seal inside the case.
- Improper alignment can cause air leaks compromising the environment inside the case and create condensation.
- Follow the five steps listed below to assure proper front glass alignment.

1. **Side-to-Side Leveling:** Place a level on top of display case (parallel to the front glass). Raise or lower either side of the case by rotating levelers to center the level bubble.

2. **Front-to-Back Leveling:** Place a level on top of case, perpendicular to front glass. Raise or lower either side of case by rotating levelers to center the level bubble. Double-check the side-to-side level.

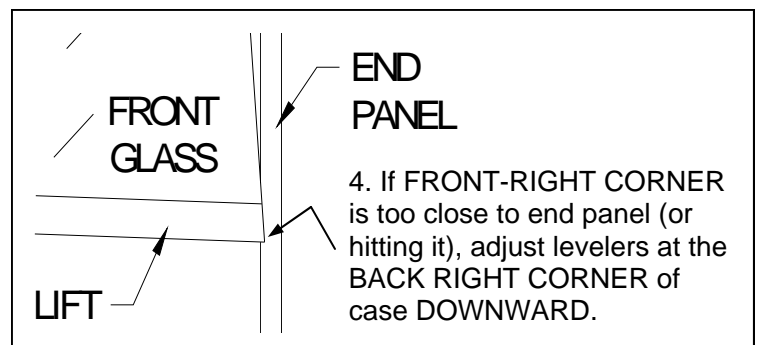
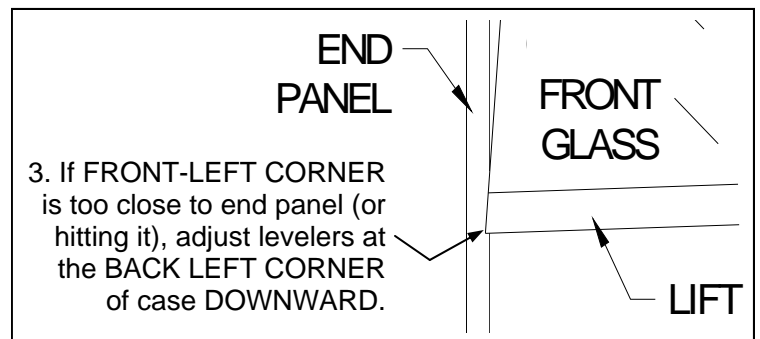
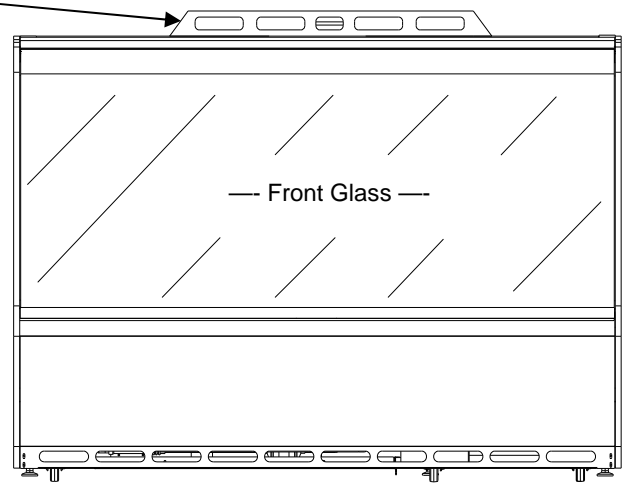
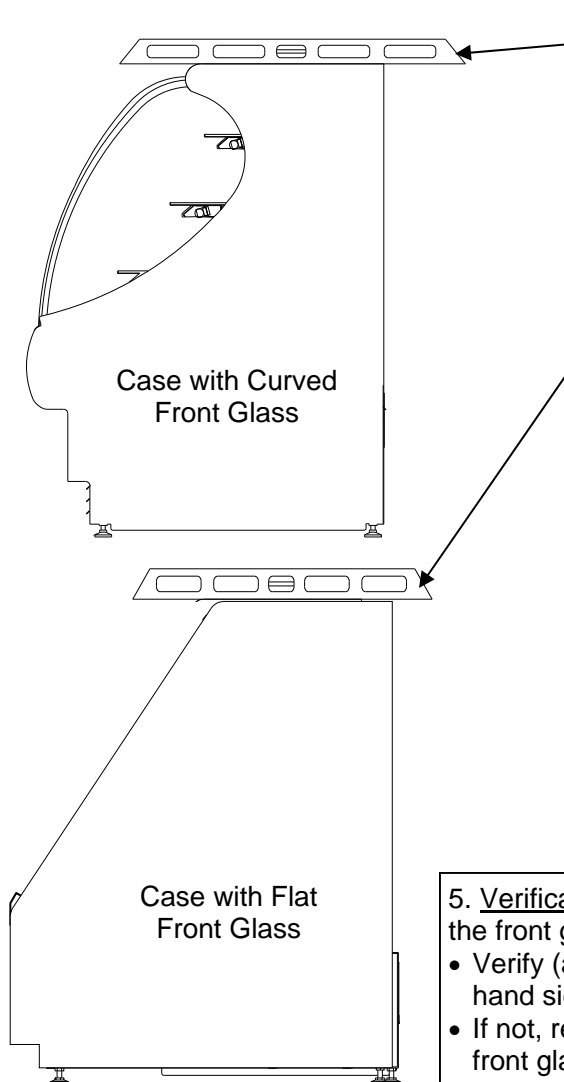

5. **Verification:** After inserting shims (or adjusting levelers), open and shut the front glass to confirm proper fit.

- Verify (again) that front glass is properly aligned at left-hand and right-hand side of the case.
- If not, repeat the shimming procedure (or leveler adjustment) until the front glass is properly aligned along both sides of the case.

11. Refrigeration Line Stub-Up Connections (Remote Units)

- Remove front panel.
- Refrigerant stub-up access opening is at the front on the left hand side of the base (see illustration at top-right).
- Stub-up connections are accessed from inside the case.
 - Remove interior ABS decks.
 - Remove fan shroud assembly.
- Line connections are in the tub front, on the left hand side
- Remove foam material from the entry hole provided in the tub drain trough.
- Route refrigerant lines through access hole.
 - Run case-to-case connections through cutouts in base.
 - Sweat the high and low pressure connections.
- Fill access hole with suitable filler to insure watertight integrity of tub.
- Illustration at top-right may not reflect every feature or option of your particular case.

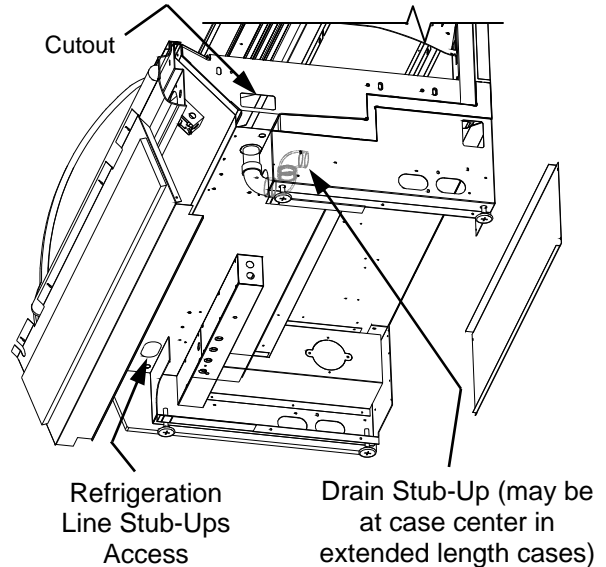

12. Refrigeration Drain Connection (Remote Units)

- Depending upon drain access needs, either front or rear panel may be removed to gain access to drain stub-up.
- 1.5" male PVC stub-up connection is under the case on the right hand side.
- Drain stub-up may be at case center in extended length cases.
- Connect tub drain to floor drain. Maintain 1/4"-fall per foot to provide proper drainage.
- Illustration at top-right may not reflect every feature or option of your particular case.

13. Evaporator Pan / Drain Position (Self-Contained Units)

- Remove the Rear Panel by lifting up & out.
- Slide the Condenser Unit out from case.
- Condenser Unit access is now available.
- Insure that the evaporator pan is installed under the PVC condensate drain trap.
- Insure that the evaporator pan is plugged into the receptacle inside base.
- Lower rear panel back into place.

- See **Drain, Hose and Bracket Placement** section in Operating Manual for details.

14. Electrical Wiring Diagram

- Each case has its own wiring diagram folded and in its own packet.
- Wiring diagram placement may vary; it may be placed near condenser fan cover, ballast box, raceway cover, or other related location.

15. Ventilation and Clearance

- **Self-Contained** refrigerated cases must maintain airflow clearance of 6" (minimum) to 12" (recommended) at front and rear.
- Restriction of air can void warranty.
- Illustration below may not reflect every feature or option of your particular case.

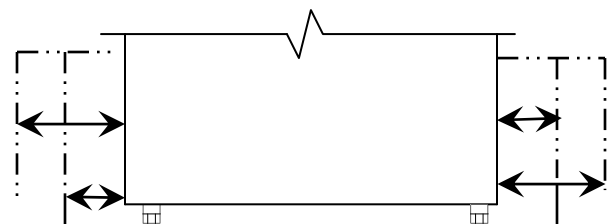

Check air grilles for obstructions.
Maintain airflow clearance of 6" (min.) to 12" (recommended) at front & rear.

16. Display Case Start-Up

A. Case

- Turn main power on at case rear.
- From the front of the case, lift curved front glass by grasping lift handle and raising (see illustration at right).
- Lift deck to check that coil fans are running.
- Coil fans (and in self-contained units, compressor motor) should turn on.

B. Rear Storage (Model HVOU[L]RSS only)

- Illustration below reflects view of rear storage area on model HVOU[L]RSS.
- Rear sliding doors provide access to area.

Rear Storage with Access via Rear Sliding Doors

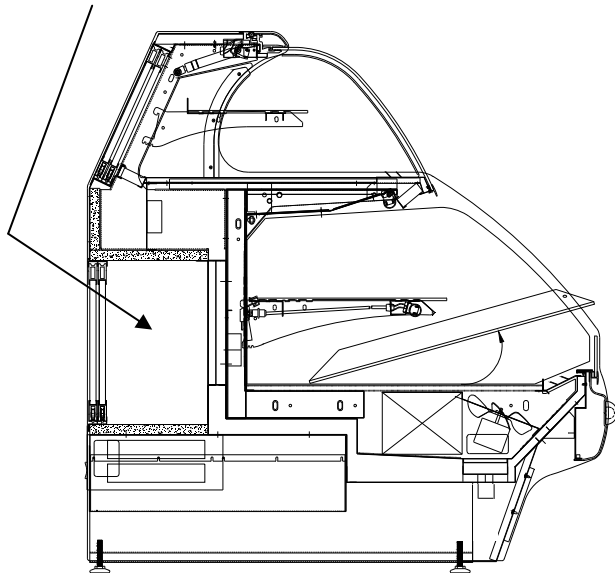

Model HVOU[L]RSS: Rear Storage with Access via Rear Sliding Doors

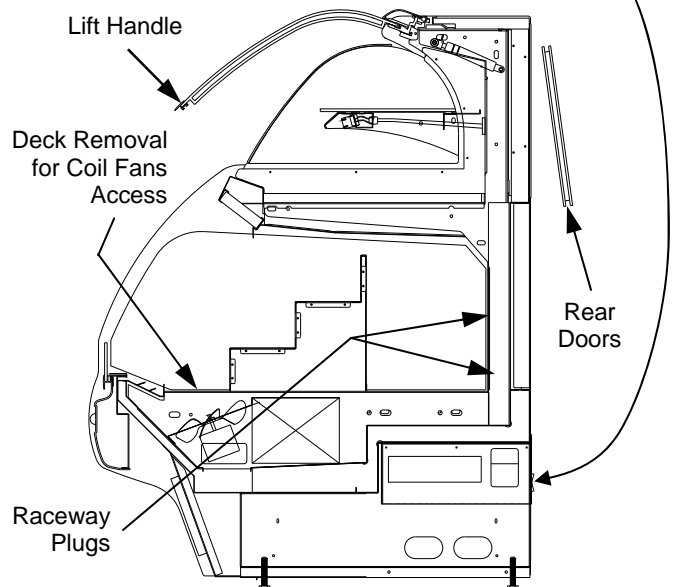
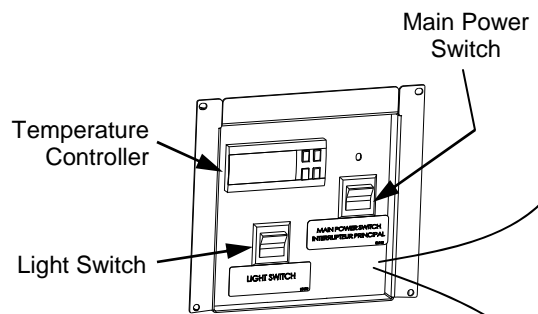
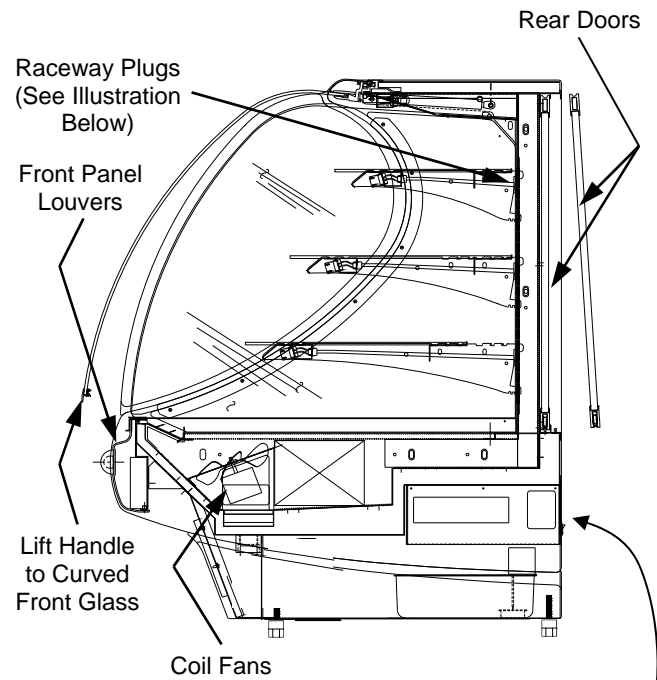

C. Lights

- Turn lights on.
 - ⇒ Self-Contained units: Switch at rear.
 - ⇒ Remote cases: NO SWITCH (lights come on when main power switch is turned on).
- All lights should come on at the same time. First time lighting may require a short warm-up period.
- Slightly dim / flickering of new bulbs is normal. If lights do not turn on, check raceway plugs.
- Lighting is wired in series so **all lights must be plugged in or receptacles capped** for case lights to be on. See illustration below right.
- LED Lights: If lights do not come on, check that plug is properly inserted into socket.

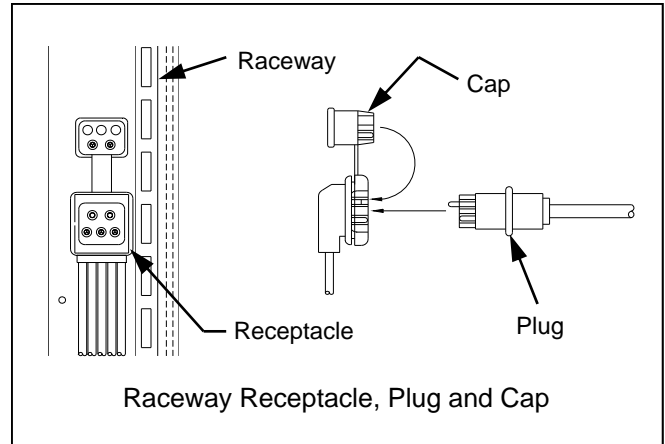

D. Temperature Controller (All Self-Contained Units and some Remote Units)

- Check that compressor symbol light is on.
- Depending upon SCC-Supplied temperature controller, compressor is identified with either:

 Compressor symbol (common in Carel® temperature controllers).

 Snowflake symbol (common in CPC® temperature controllers).

- After case has run for a few minutes, check that temperature starts to drop.
- If temperature controller does not begin cooling (in a few minutes) see temperature controller section in this operating manual for instructions.
- Remote units (without temperature controller on case): Verify that refrigeration requirements listed on serial label (found on the case) are being met.



Sample Carel® Controller Face



Sample CPC® Controller Face

E. Saturated Suction Temperature (Remote Units)

- See serial label on case for suction temperature requirements and BTU requirements.
- See serial label on case for defrost schedule and temperature termination parameters.

BAFFLES: AMBIENT VS. REFRIGERATED CONDITIONS

Baffles: Ambient vs. Refrigerated

Certain sections of the case can be either ambient or refrigerated (depending upon type of product being displayed).

A dual-purpose baffle is provided to facilitate desired condition. It is accessible through rear doors.

The baffle will prevent (or allow) refrigerated air from circulating through the display area and returning through the air return grille.

1. For ambient (non-refrigerated) conditions, baffle must be positioned to block air flow. See photo #1 at top right. *Note: Depending upon model, options and features chosen, photos may not exactly reflect every aspect of your particular case.*
 2. To switch from ambient to refrigerated condition, lift baffle up and out of air chamber. Rotate 90 degrees so arrows on the tag point down and tag is to the rear of the case. Lower baffle, with slots facing up, back down into the air chamber. See photo #2 at mid-right.
 3. For refrigerated conditions, baffle is positioned to allow air to circulate through display area and return through air return grille. See photo #3 at lower-right.
- *Note: To clean, remove baffle from case, brush out crumbs or residue from baffle. Wipe down with clean rag dipped in mild soap and water solution.*

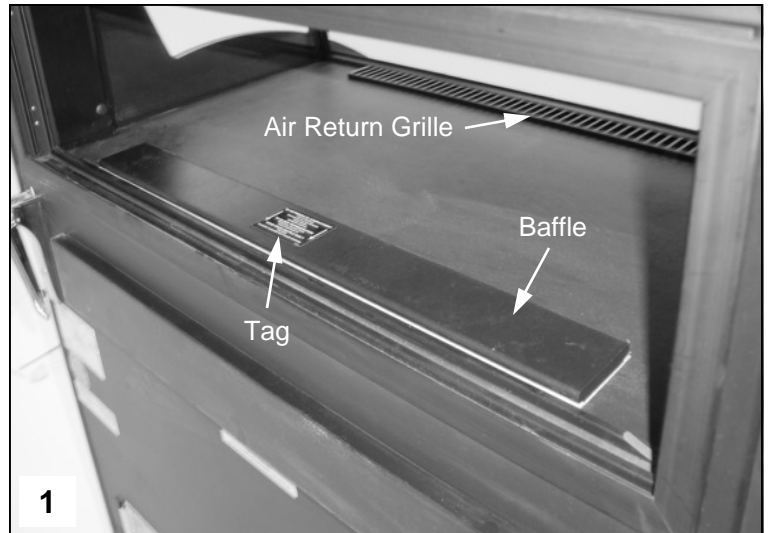

Photo of Baffle in Ambient (Non-Refrigerated) Position

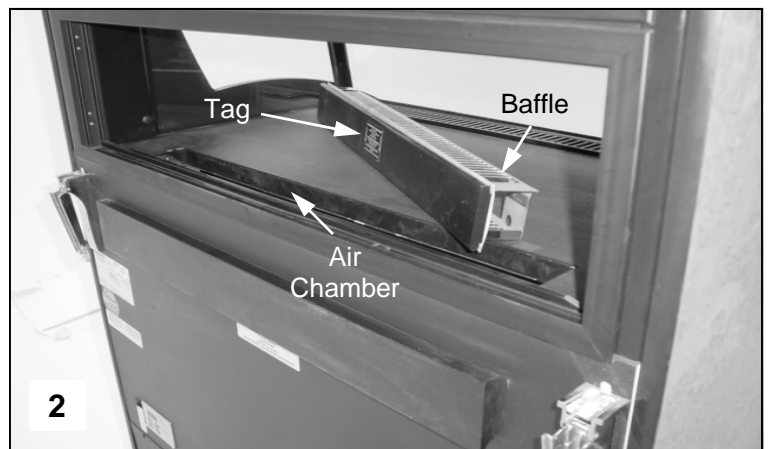

Photo of Baffle Removed From Chamber

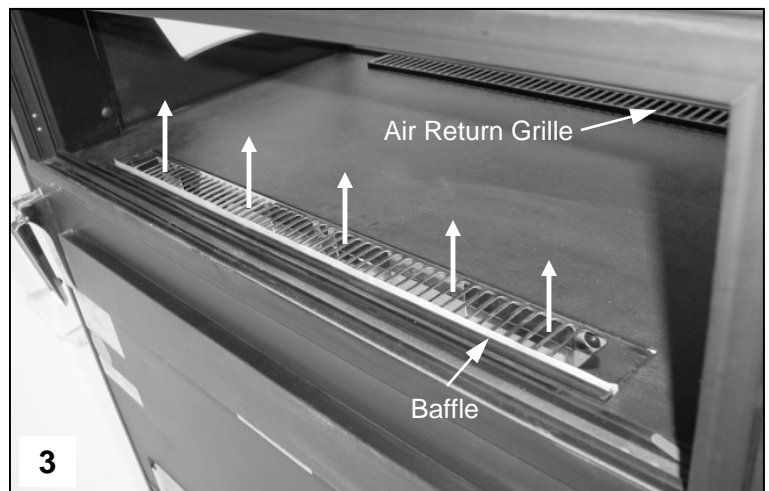
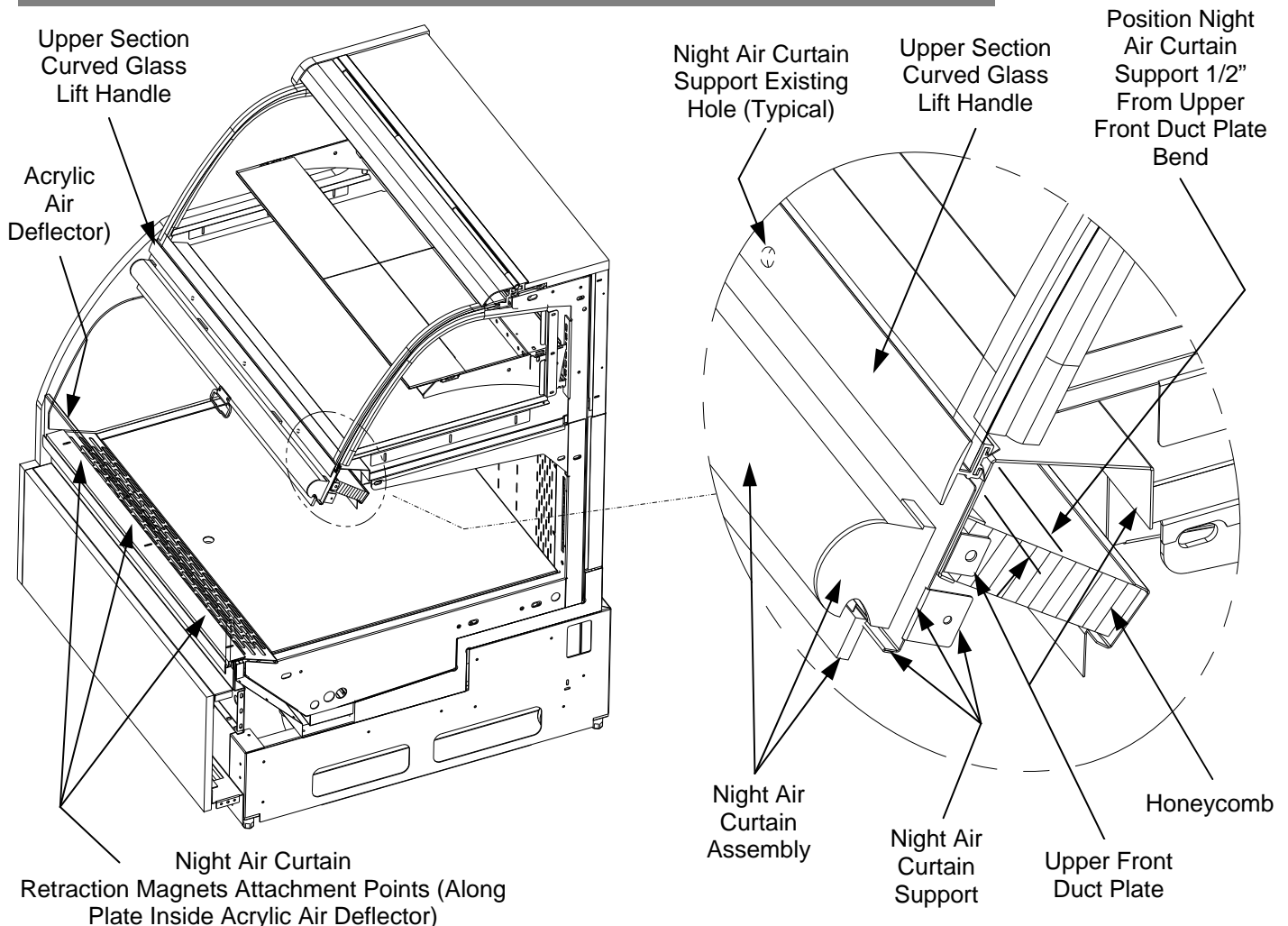

Photo of Baffle in Refrigerated Position. Note: Airflow Direction

Night Air Curtain Installation & Operating Instructions

1. Use caution when handling Night Air Curtain.
2. Display case may come with Night Curtain already attached. If not, a retrofit kit will be provided. If using SCC-supplied retrofit kit, attach the Night Air Curtain Support to the existing Upper Front Duct Plate (see illustration below). To attach, grasp the lift handle of the Upper Section Curved Glass and lift upward; hydraulic cylinder will keep glass raised. Use the Night Air Curtain Support (as a template) by placing it 1/2" from Upper Front Duct Plate Bend (as shown below). Mark locations of existing hole(s) onto Upper Front Duct Plate. Drill clearance holes for #10 screws at these points.
3. Place Night Air Curtain Support into position and use the SCC-supplied screw(s) to attach it to the Upper Front Duct Plate (where pilot hole[s] were just drilled).
4. Upper Section Curved Glass may now be lowered back into closed position.
5. Night Air Curtain Assembly may now be placed on the Night Air Curtain Support. Carefully positioned magnets will keep in place. Grasp handle and pull downward to desired location INSIDE acrylic air deflector (see illustration below).
6. To return Night Air Curtain to its retracted position, grasp handle, lift up and away from its magnetic attachment and carefully wind Night Air Curtain back into roll.
7. **Caution!** Do not allow spring-loaded Night Air Curtain to freely snap back into roll. Doing so can eventually destroy Night Air Curtain's tension and retractability.
8. **Note:** Due to ONLY the magnets keeping Night Air Curtain Assembly in place, it may be removed at any time by firmly lifting up and off Night Air Curtain Support.

NOTE: THE BELOW ILLUSTRATION MAY NOT EXACTLY REFLECT EVERY PARTICULAR CASE'S FEATURES OR OPTIONS.



Night Air Curtain Installation & Operating Instructions

1. Use caution when handling Night Air Curtain.
2. Display case may come with Night Curtain already attached. If not, a retrofit kit will be provided. If using SCC-supplied retrofit kit, place night curtain on top of case as shown. Mark "keyslot" locations using night curtain as a template (you may have to retract the curtain from housing to reveal "keyslots". Drill $\varnothing 11/32$ " holes in top board $1/2$ " deep. Press the "finserts" (shown below) into holes. Carefully tap in with flat object to prevent top board damage. Attach Night Air Curtain with #10-32 screws.
3. Grasp the handle and pull downward to desired location **INSIDE** acrylic air deflector.
4. To return Night Air Curtain to its retracted position, grasp handle, lift up and away from its magnetic attachment and carefully wind Night Air Curtain back into roll.
5. **Caution!** Do not allow spring-loaded Night Air Curtain to freely snap back into roll. Doing so can eventually destroy Night Air Curtain's tension and retractability.
6. To entirely detach Night Air Curtain from case, retract curtain (to access keyslots), remove screws. Lift Night Air Curtain upward and away from case.

NOTE: THE BELOW ILLUSTRATION MAY NOT EXACTLY REFLECT EVERY PARTICULAR CASE'S FEATURES OR OPTIONS.

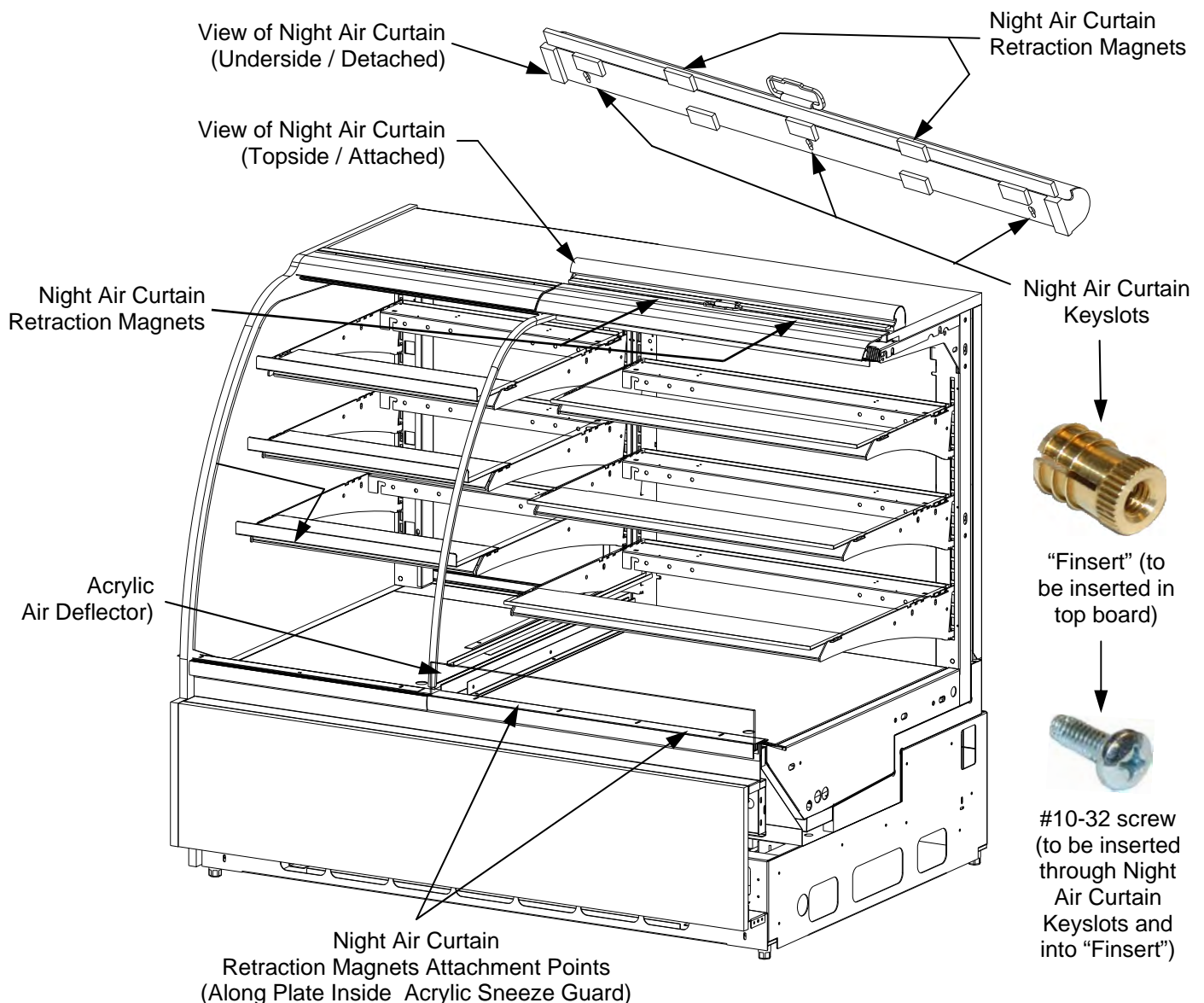

1. Initial Positioning and Installation of Security Brackets

1. Illustration below has Security Grid removed and end panel removed for more precise viewing.
2. Attach Security Brackets (one at each end) to Upper Front Duct AND to end panel. Use No. 10 black screws to securely position Security Brackets before installing Security Grid.
3. The next page in this manual will show how to position and install the Security Grid.
4. Right Side View shows illustration of Security Brackets after Security Grid installed.

**NOTE:
ILLUSTRATION
MAY NOT
EXACTLY
REFLECT YOUR
CASE'S
FEATURES OR
OPTIONS**

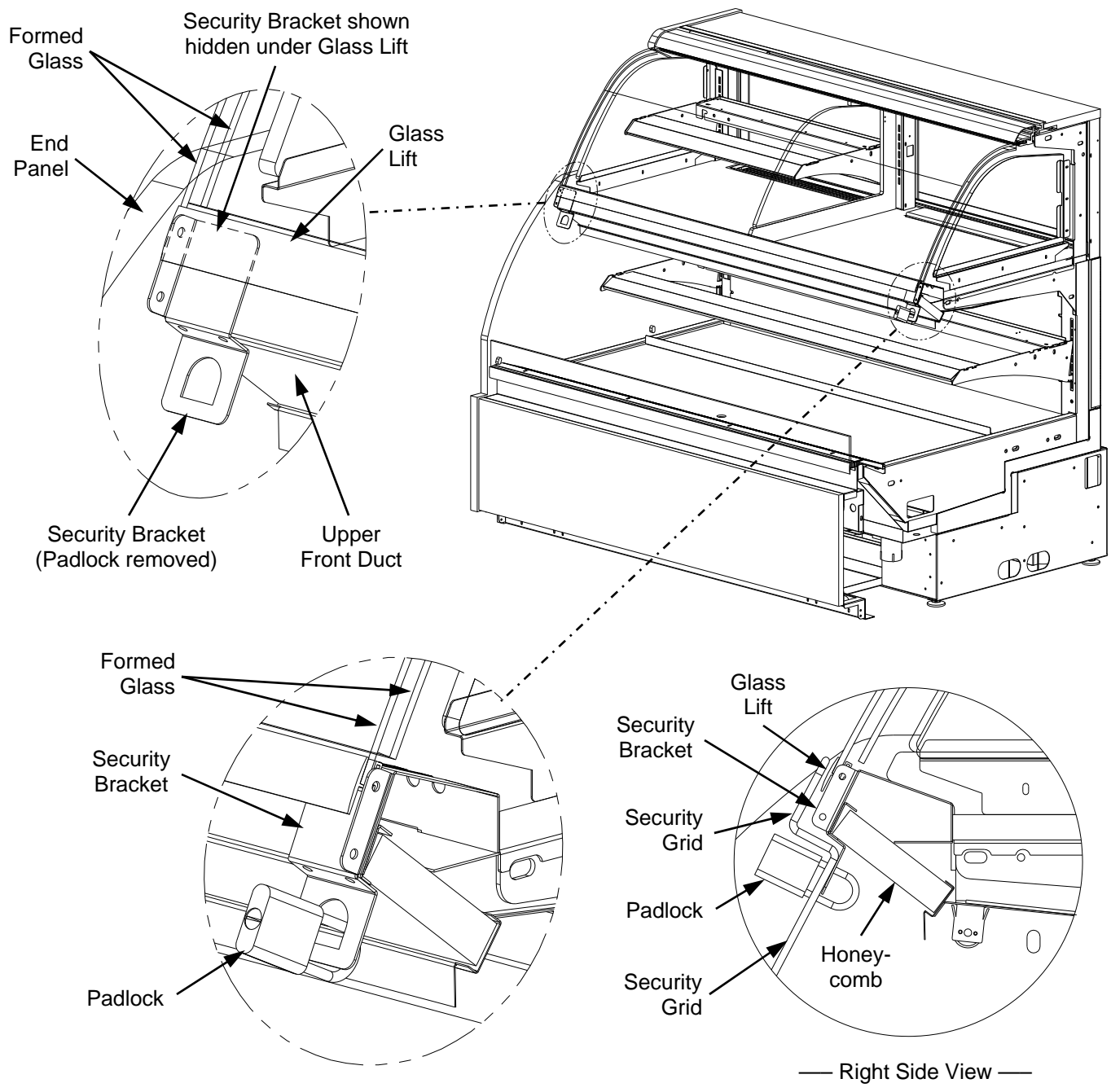

2. Initial Positioning and Installation of Security Grid

1. Due to weight and size, Security Grid installation requires two (2) people.
2. After hoisting Security Grid directly over Front Air Deflector, drop the (2) Security Grid Positioning Tabs into the Baffle Airflow Slots (see enlarged view below).
3. After securely positioned in the Baffle Airflow Slots, carefully and slowly lean the Security Grid back against the two Security Brackets.
4. Enlarged View (shown below) shows Security Grid Positioning.
5. Tabs must be securely positioned into Baffle Airflow Slot. There is one Security Grid Positioning Tab on each end of Security Grid.
6. Tabs must be securely positioned in both Airflow Slots prior to locking with Padlocks.

**NOTE:
ILLUSTRATION
MAY NOT
EXACTLY
REFLECT
YOUR
CASE'S
FEATURES
OR OPTIONS**

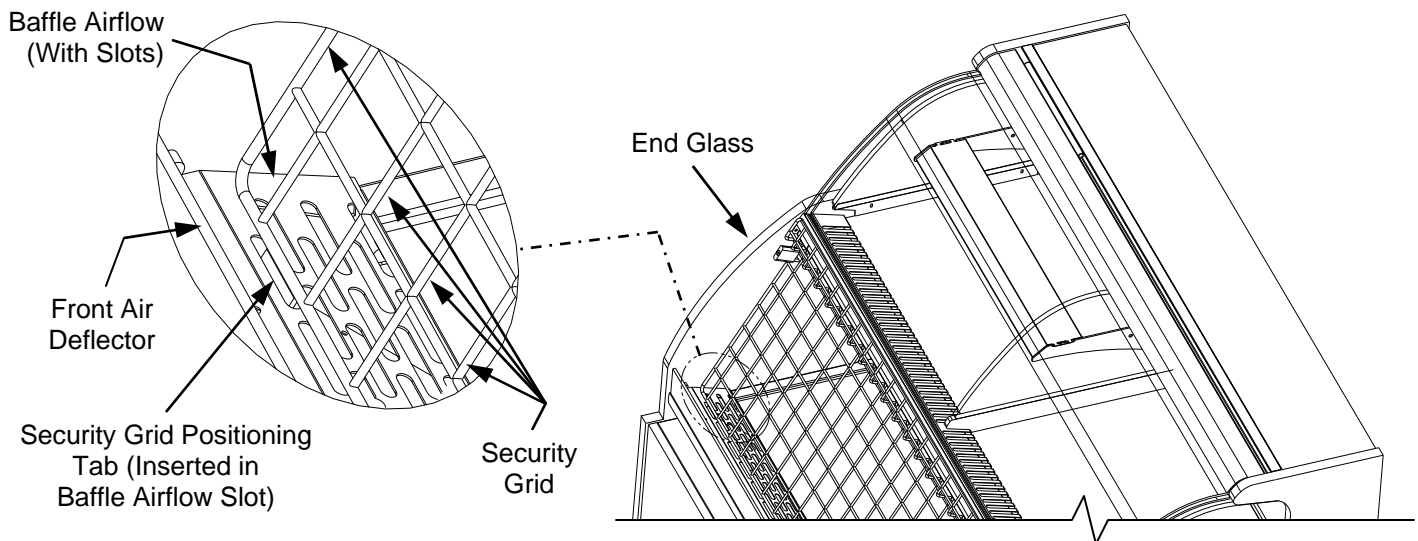

3. Securing Security Grid Into Place and Locking

7. After leaning the Security Grid back against the two Security Brackets, slide the (two) Padlocks through the Security Grid and the Security Brackets.
8. Securely lock the Padlocks (one Key fits both Padlocks).

4. Removing and Storing Security Grid and Locks

9. Due to weight and size, Security Grid removal requires two (2) people.
10. Unlock and remove Padlocks. Lean Security Grid forward. Lift upward and out of Baffle Airflow Slots.
11. Store Security Grid, Padlocks and Keys in a secure location to prevent theft or damage.

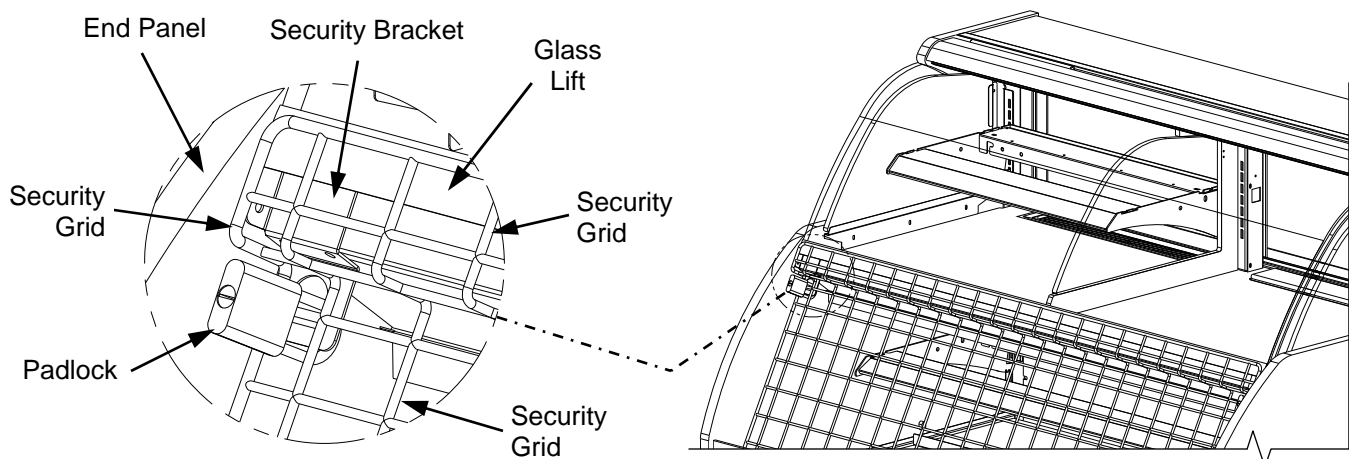

SECURITY GRID INFORMATION FOR MODEL HVLD[L]RSS ONLY

1. Initial Positioning and Installation of Security Grid

1. After hoisting the Security Grid directly over Front Air Deflector, drop (2) Security Grid Positioning Tabs into the Baffle Airflow Slots (see enlarged view below).
2. After securely positioned in the Baffle Airflow Slots, carefully and slowly lean the Security Grid back against the two Security Brackets.
3. Illustration below shows Security Grid Positioning Tab slid into Baffle Airflow Slot.. There is one Security Grid Positioning Tab on each end of Security Grid.
4. Tabs must be securely positioned in both Airflow Slots prior to locking with Padlocks.

**NOTE:
ILLUSTRATIONS
MAY NOT
EXACTLY
REFLECT EVERY
PARTICULAR
CASE'S
FEATURES**

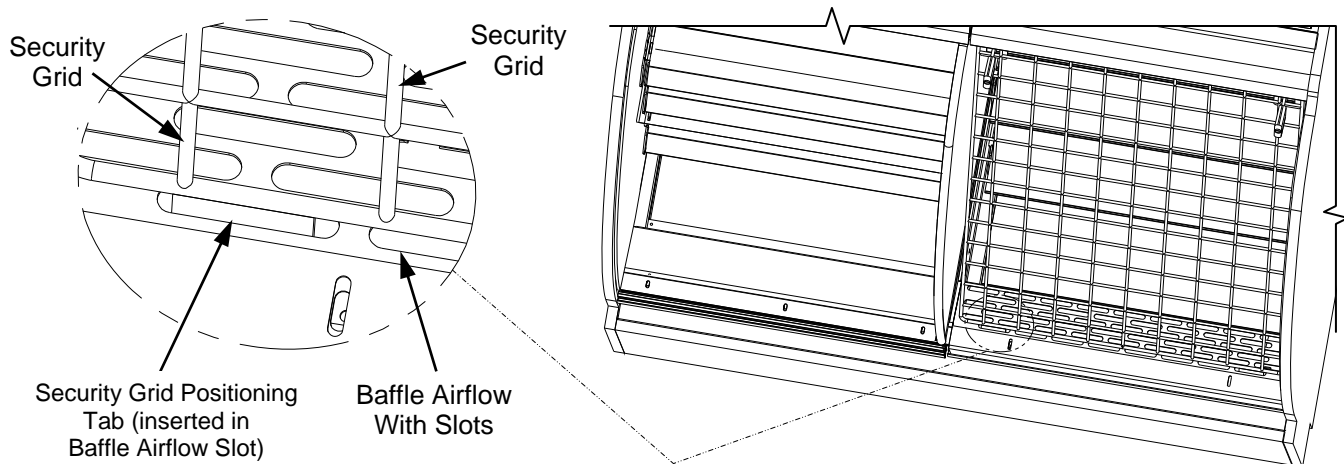

2. Securing Security Grid Into Place and Locking

5. After leaning the Security Grid back against the two Security Brackets, slide the (two) Padlocks through the Security Grid and the Security Brackets.
6. Securely lock the Padlocks (one Key fits both Padlocks).

3. Removing and Storing Security Grid and Locks

7. Unlock and remove Padlocks. Lean Security Grid forward. Lift upward and out of Baffle Airflow Slots. Tabs fit into (and slide out of) baffle slots as in other units. See next page tab and baffle slot locations and illustrations.
8. Store Security Grid, Padlocks and Keys in a secure location to prevent theft or damage.

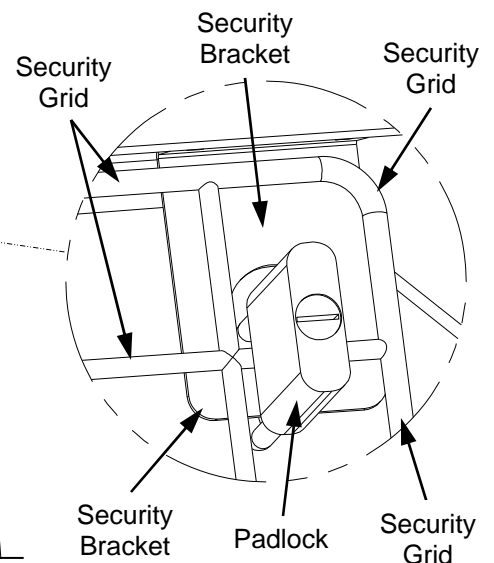

DRAIN, HOSE AND BRACKET PLACEMENT ILLUSTRATIONS

NOTE: BELOW ILLUSTRATIONS MAY NOT EXACTLY REFLECT EVERY PARTICULAR CASE'S FEATURES

Three Evaporator Systems Are Illustrated Below:

Illustration #1: Hot Gas "CopeVap" Evaporator System. "Copevap" is built into Compressor Unit.

Illustration #2: Hot Gas Evaporator System.

Illustration 3A/3B: Electrical Heat Rod Evaporator System. **Note:** Separate Evaporator Pan.

Warning! Regardless of Evaporator, the Hose and Drain Trap **MUST BE** secured and positioned over Evaporator Pan to prevent water seepage / spillage. When sliding out Condenser Unit, be careful that drain is not pulled from proper position.

1. Hot Gas "CopeVap" Evaporator System.

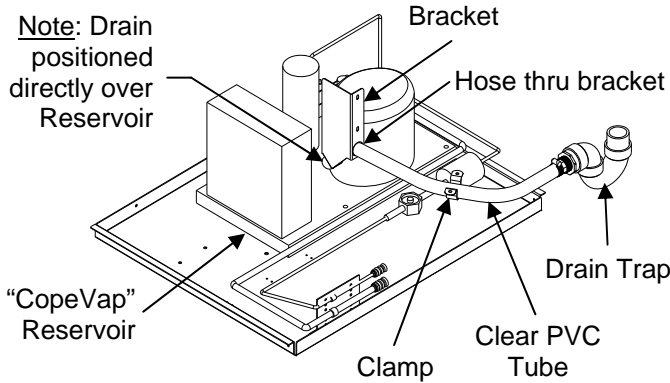

3A. Front View of Electrical Heat Rod Evaporator System

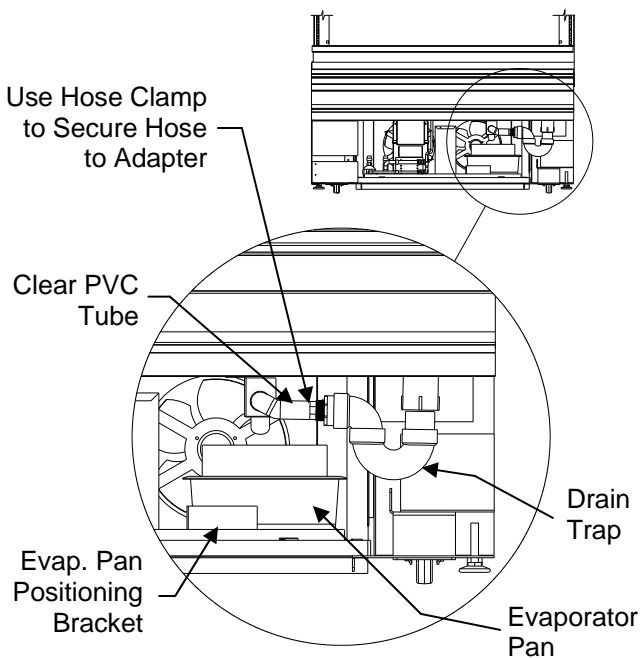

2. Hot Gas Evaporator System.

- Hot gas serpentine coil is routed through a condensate reservoir allowing water to be heated. This system uses a wicking material (partially submersed) with warm condenser air passing through it for evaporation.
- Also incorporates an overflow reservoir with heating element to ensure complete condensate removal.

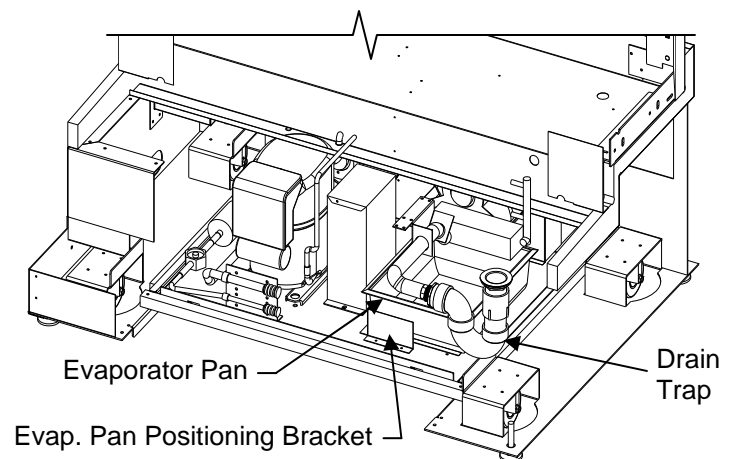
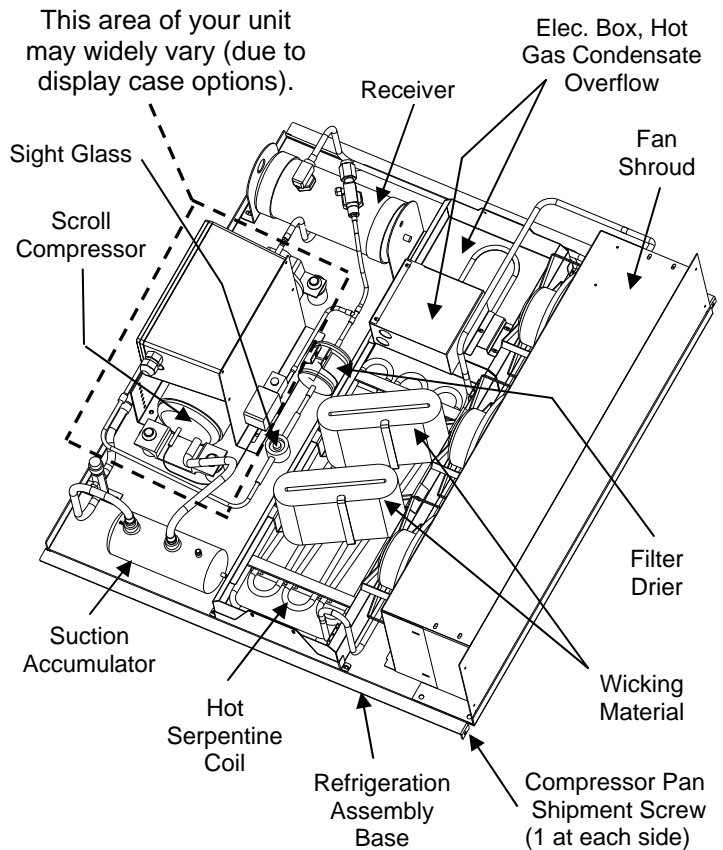

3B. Isometric View of Electrical Heat Rod Evaporator System

Warning! Disconnect power before providing maintenance and service to unit.

Caution: Lamps are treated to resist breakage and must be replaced with similarly treated lamps.

Note: Warranty will be void if claims arise from negligence, misuse of goods, extreme environmental conditions or improper maintenance. See Overview And Warnings section in manual.

1. Rear Sliding Doors

Note: Doors are not interchangeable. There is an inner and outer door. Outer door must be removed first and replaced last. See illustration at top-right.

- The outer door is the right hand door (from the service side or rear of case).
- Move doors toward the center of the case.
- Individually lift each door up toward the top of the case; pivot the bottom of the door out.
- Replace rear sliding doors in reverse order they were removed.

2. Light Fixtures

Note: Depending upon model and options, light fixtures can have either single or dual lamps.

Light fixtures are located on underside of shelf assemblies and at the top inside of case. See illustration at right for general locations.

Removal of lamps:

- Rotate lamp (1/4-turn) to disengage (upper or lower) pins/contacts from mounting sockets.
- Remove bulb by applying even pressure from back side at the bulb ends and pulling the remaining contact from sockets.
- See illustrations at mid and lower-right.

Installation of lamps:

- Align pins with slot.
- Insert pins into socket by rotating the bulb 1/4-turn to secure either the (upper or lower) pin contacts into the sockets.
- Rotate remaining bulb contacts (1/4-turn) into remaining lamp mounting socket contacts.
- See illustrations at right.

See next page for LED Light Fixture information.

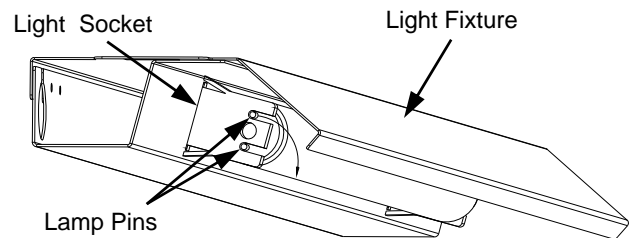
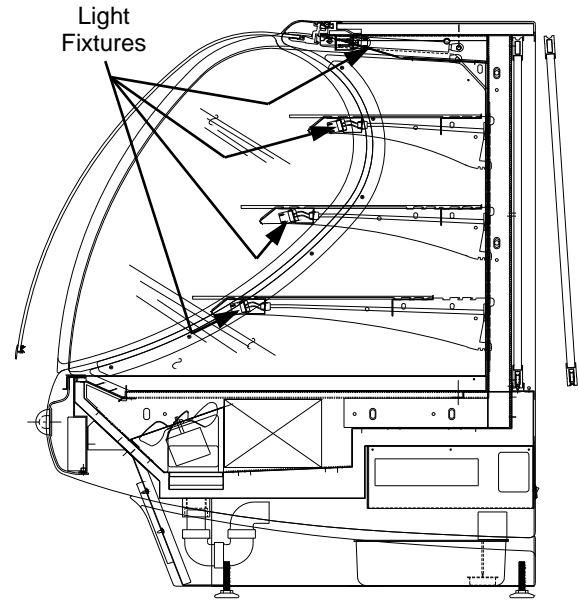

Single Lamp Light Fixture

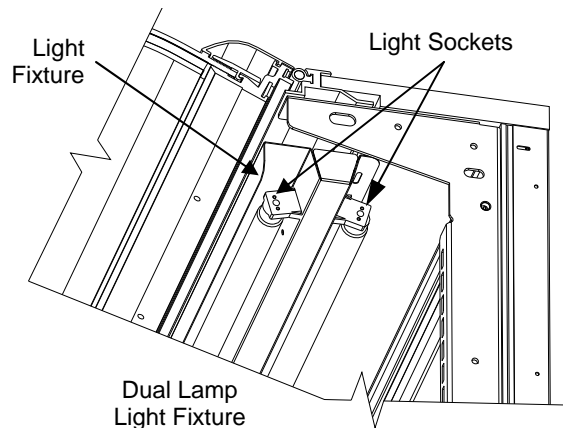

Dual Lamp Light Fixture



1. LED Light Removal / Replacement

- LED lights they rarely require change-out.
- Contact Structural Concepts' Technical Service Department for replacement parts (see Technical Service section of this guide).
- To remove LED light fixture, disconnect existing LED light from its brackets & self-adhesive tape.
- Then, firmly grasp LED light while applying outward pressure to brackets.
- Twist the LED away from the bracket to release.

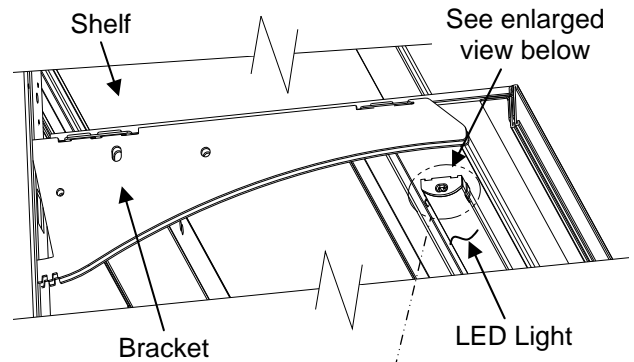

2. Plug and Cord Positioning

- Plug is to connect to LED light at raceway side of case.
- Before attaching LED light to case, plug must connect to LED properly without cord doubling-back.
- See photos of proper vs. improper connections.

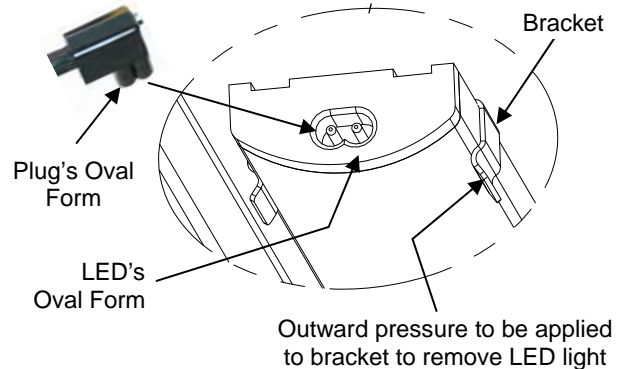

3. Proper Plug Insertion Into LED Light

- Plug must be inserted into LED light properly or the LED will not light up.
- Oval form of plug is to connect to LED light oval form.
- See illustration at right.

See previous page for Standard Light Fixture information.

4. Bracket Retainer Removal

- To remove brackets, it may be necessary to remove the nylon shipping bracket retainers.
- Pliers will be required to accomplish this task.
- See illustration at top-right for location of bracket retainers.

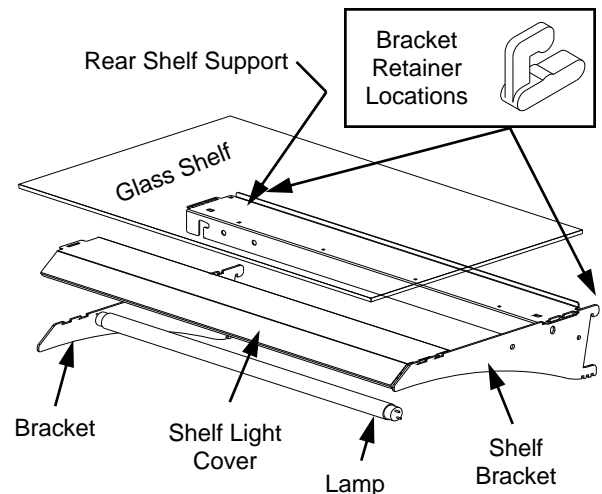

5. Shelf Assembly Removal

- Remove glass shelves
- For lighted shelving, unplug the light cord.
- Remove rear shelf support.
- Remove shelf light cover from brackets.
- Lift brackets up and out.

6. Drain and Expansion Valve Access

- The drain and expansion valve are both accessible from the front of the case.
- Unplug the fans (one plug per side) and remove the fastener from the access panel in the front right (or left) corner of the unit.
- The drain and the expansion valve (TXV) are directly below the access panel.

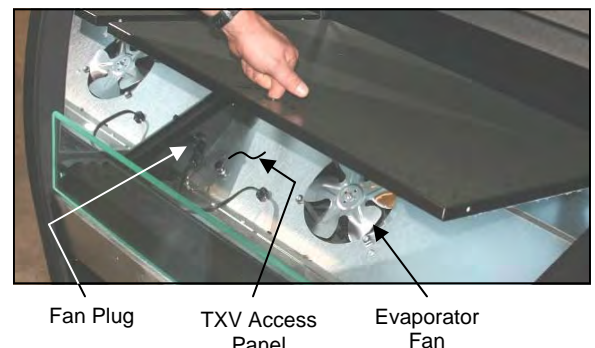

1. Refrigeration Pkg. Access [Standard Units]

Note: See Next Page for EnergyWise Refrigeration Package Configurations

Caution: Servicing to be accomplished by licensed electrical / refrigeration contractor.

2. Air Filter

- Magnetic strips attached to the filter adhere the filter to the rear grille.
- Clean the nylon mesh filter by rinsing thoroughly with water against the air flow direction.
- Mild detergent removes smoke & grease stains.
- See illustration at top-right.

3. Pull Out Refrigeration Package

- Remove the rear grille. Grille may be slid upward and out or removal of two screws may be required.
- **Note:** At initial slide-out, it may be necessary to remove Compressor Pan Shipment Screws (see illustration at right for location).
- *Refrigerant lines are flexible to facilitate rear access maintenance.*
- Plastic glides are mounted at base to assist in sliding the condenser out for access.
- Service connections are at the left of compressor.
- Slide condenser unit out 12 to 18 inches to access high pressure service connection.

4. Temperature Controller (Self-Contained Units Only)

- Temperature Controller is located in the ballast box.
- Temperature / Defrost control settings are programmable from these locations.
- Case Temperature Set Point is set at the factory, as determined by case size & sensor probe location.
- Temperature is controlled by thermostat.
- If a temperature setting change is required, follow instructions regarding Temperature Control Programming Steps in the technical information section of this operating manual.
- If service is required to the temperature control unit, call Structural Concepts Corporation. Maintenance should be performed by a certified technician.
- The toll-free number is listed in the Technical Service section of this manual.
- See Temperature Controller section in this manual.

NOTE: Digital or spirit-filled thermometers provided with equipment monitoring warmest air temperature only [not

Note: Illustrations below may not depict exact representations of your particular unit.

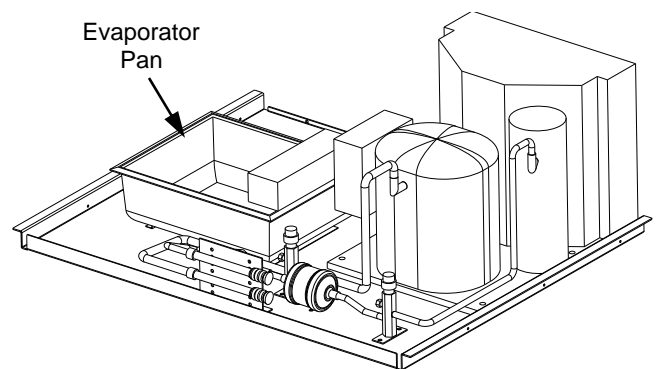
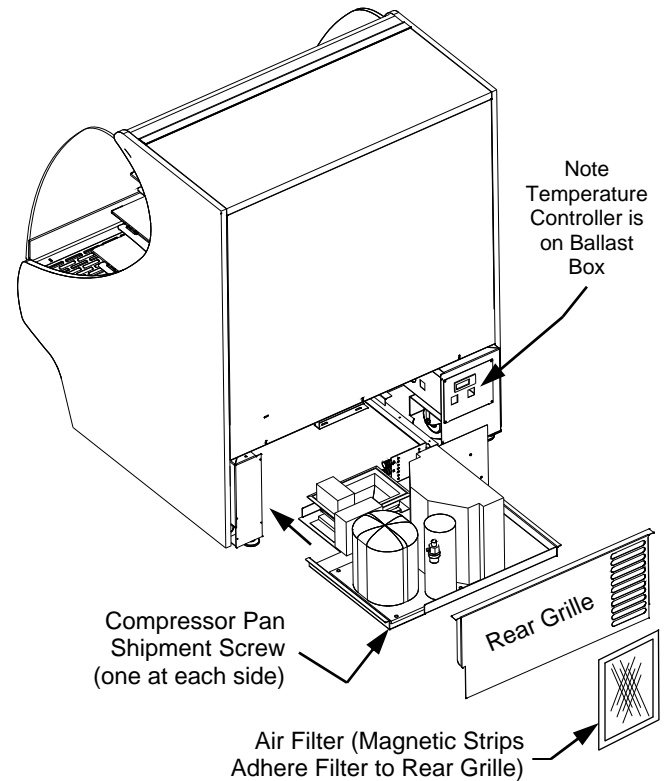

actual food temperature]. Use probe thermometers to determine actual product temperature.

5. Evaporator Pan Access / Removal

- Turn off main power; allow evaporator pan to cool.
- Lift Rear Grille up and off (no tools required).
- **WARNING! Evaporator Pan May Be Hot!** Check temperature of pan prior to handling.
- Withdraw evaporator pan from the right side behind electrical box.
- Unplug evaporator pan from the electric outlet.
- Empty evaporator pan contents into suitable

MAINTENANCE FUNDAMENTALS - ENERGYWISE REFRIGERATION PACKAGE LAYOUT

EnergyWise Refrigeration Package Configuration [Model HOU3852R.5149 and Others]

- Note: Your particular compressor may have slightly different EnergyWise refrigeration package layout.

1	Fan Shroud / Condenser Coil Cover: (Optional: May Have Shroud Attached to House Clean Sweep™ Automatic Condenser Coil Cleaner)	7	Hot Gas Condensate Evaporator Pan
2	Fan Motor & Bracket	8	Hot Gas Loop
3	Condenser Coil Tubing	9	Sight Glass
4	Receiver	10	Filter / Drier
5	Electrical Box (To Overflow Condensate Pan)	11	Hot Gas Loop Compressor
6	Overflow, Hot Gas Condensate Evaporator Pan	12	Start Components, Hot Gas Loop Compressor

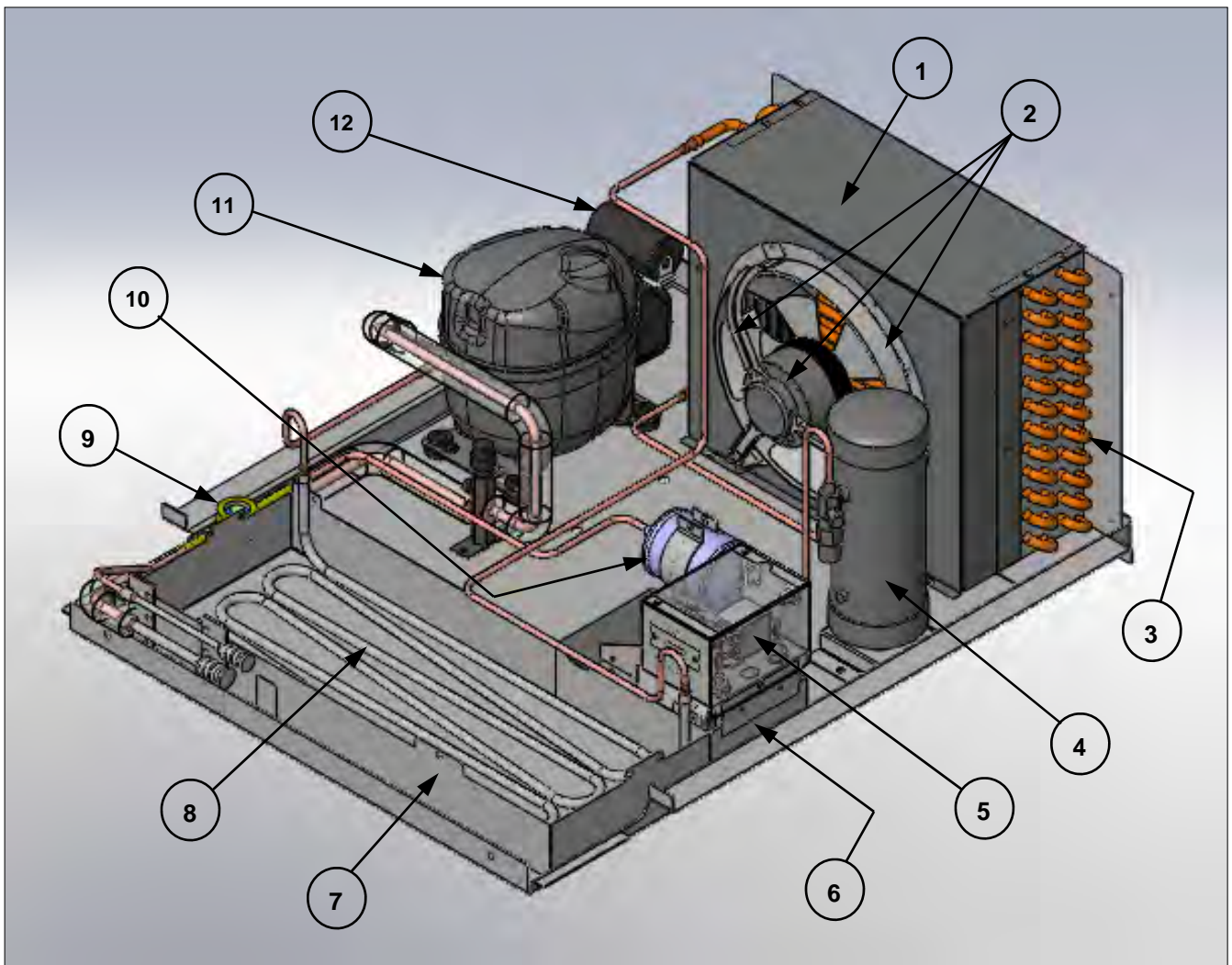

EnergyWise Refrigeration Package: Model HOU3852R.5149 Shown Above
 [Note: Your Package Layout May Slightly Vary]

Preventive maintenance should be performed every 30 days unless conditions warrant a more frequent replacement cycle.

1. Honeycomb Air Diffuser Removal

- A. Wedge non-metallic device of suitable strength (such as a ballpoint pen) between honeycomb and end panel.
- Caution!** Use care not to dislodge the heating wire (that prevents condensation on the lamp assembly).
- B. Apply pressure to collapse the honeycomb to allow it to be pulled out of honeycomb retainer.
- C. Pry downward and away from honeycomb retainer.

Clean honeycomb with warm water and soap solution. Submerge if necessary. Use brush to dislodge stubborn or sticky residue. Dry by using vacuum's 'blow mode'.

2. Honeycomb Air Diffuser Installation

- D. Squeeze honeycomb into the honeycomb retainer.
- E. Carefully slide honeycomb into place.
- F. Adjust honeycomb so that it fits flat against retainer. It must not be wavy or out of position.

Note: For honeycomb air diffusers in other locations, these same general instructions apply.

3. Air Duct - Upper Section (Top-Right Illustration)

- Depending upon model, Upper Section Air Duct may be removable for cleaning. If so, simply lift Air Duct up and out of chamber to access area to clean.
- If Upper Section Air Duct is not removable from case, Honeycomb removal will allow access to area.
- Clean with brush or vacuum with brush attachment.
- Wipe down with moist cloth.

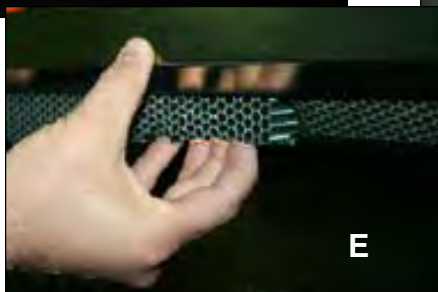
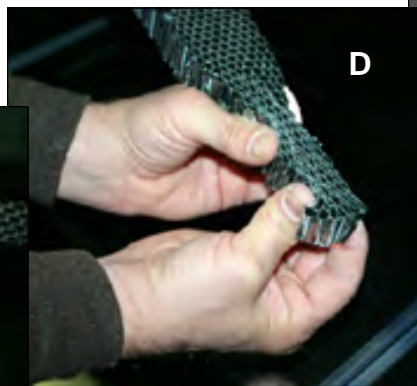
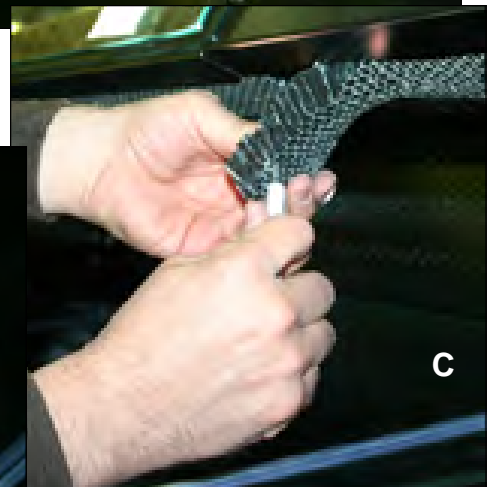
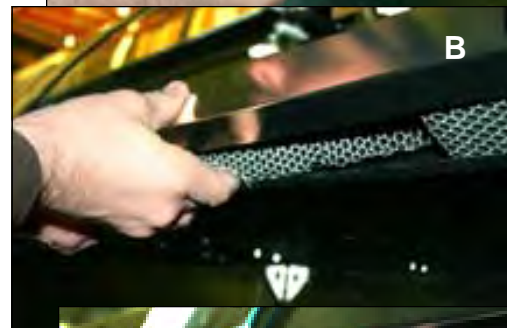
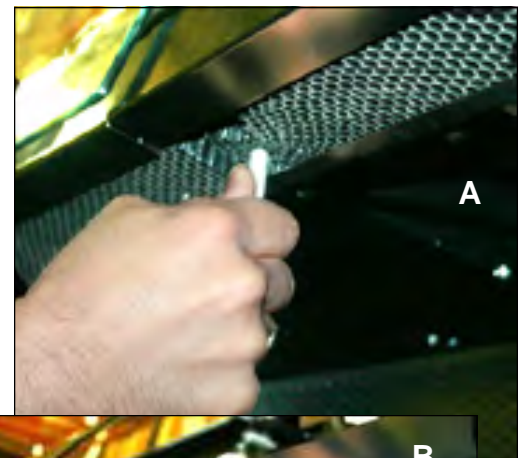
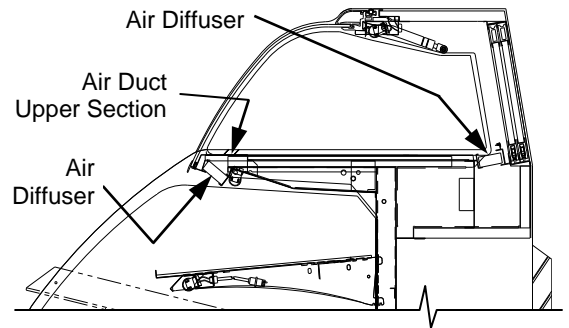

CLEANING SCHEDULE - TO BE PERFORMED BY STORE PERSONNEL

AREA	FREQ.	INSTRUCTIONS
Exterior	Daily	All Glass / Mirrors: Clean side glass, front glass, glass shelves, and mirrors with household or commercial glass cleaner. Clean out door track with moist cloth.
	Daily	Rear Sliding Door Exterior Glass: Clean with household or commercial glass cleaner.
	Daily	End Panels, Front Panel, Toe-Kick, etc.: Wipe off all surfaces with warm water and mild soap solution and non-abrasive cloth.
	Weekly	Wood, Laminate and Painted Surfaces: Clean with mild soap and water solution and a soft cloth .
	Weekly	Acrylic: Clean with warm water, mild soap solution and soft cloth; acrylic cleaning solutions are also available. Caution! Never use ammonia-based cleaners on acrylic. Incorrect cleaning agents or abrasive cleaning cloths cause surface to 'cloud' over time.
	Weekly	Air Filter (with Magnetic Strips) on Outside of Rear Grille: Remove air filter. Rinse with hot water against air flow direction. Use mild detergent to remove smoke and grease stains.
	Monthly	Condensing Coil: Remove rear grille. Vacuum or brush grille area on back of case; clean dust and dirt collecting on condenser coil. Avoid damaging fins.
	Monthly	Under Case Cleaning: Remove front toe-kick (or rear grille). Vacuum under case to remove all dust and dirt. Replace front toe-kick (or rear grille) when complete.
Interior	Weekly	Decks: Wipe off decks with moist cloth dipped in mild soap and water solution.
	Monthly	Tube and Drain: Keep clean and free of debris which could clog tube and drain. To access drain area, remove the deck and fan shroud. <ul style="list-style-type: none"> • Vacuum tube under deck. • Direct the drain to a floor drain or a bucket. • Run hose into drain to flush out debris. Carefully hose out the tube. • Caution! Avoid splattering water over the case and surrounding areas!
	Monthly	Air Return Grille and Fan Shroud Area: 1) Turn off power. 2) Remove decks from case. 3) Clean with moist cloth.
	Monthly	Honeycomb Air Diffuser: See MAINTENANCE FUNDAMENTALS - HONEYCOMB AIR DIFFUSERS section in this manual for cleaning instructions.
	Monthly	Air Duct - Upper Section: See MAINTENANCE FUNDAMENTALS - HONEYCOMB AIR DIFFUSERS / UPPER SECTION AIR DUCT section for specifics.

CONDITION	TROUBLESHOOTING
Case Not Lining Up	See Installation Section for instructions on properly aligning case (alongside other cases) and adjusting levelers.
Water Is On The Floor	<p>Caution! Water on flooring can cause much damage! Until cause is determined (and repaired), following these procedures:</p> <ul style="list-style-type: none"> • Use wet-dry vacuum (or mop & bucket) to remove standing water. • Use 'catch pans' for water to drain into. Swap out regularly until case has completely drained. <p>Note: See <i>Drain, Hose and Bracket Placement Illustrations</i> sheet in this manual for views of different evaporator systems used in display cases.</p>
	Check that the drain trap is free of debris.
	Check that the drain hose is correctly positioned over evaporator pan (or floor drain, for remote units).
	Check store conditions. To prevent condensation in NSF® Type 1 environments, maximum conditions are to be 55% humidity / 75° Fahrenheit. For NSF® Type 2, maximum conditions are to be 60% humidity / 80° Fahrenheit. See serial label (at case rear near main power switch) for NSF® Type of your case.
	Check evaporator pan float for proper operation (Heat Rod Evaporator System only).
	Check that evaporator pan is plugged in.
	<p>Caution! Evaporator pan may be malfunctioning (Electrical Heat Rod Evaporator system). If so, water will overflow pan and seep onto flooring causing damage! Until evaporator pan is functioning (or is replaced), following these procedures:</p> <ul style="list-style-type: none"> • Use wet-dry vacuum (or mop & bucket) to remove standing water. • Use 'catch pans' for water to drain into. Swap out regularly until case has completely drained.
	<p>Caution! Disruption of power can cause water to overflow pan and seep onto flooring causing damage! Check that power to case is constant. Until power is restored, following these procedures:</p> <ul style="list-style-type: none"> • Use wet-dry vacuum (or mop & bucket) to remove standing water. • Use 'catch pans' for water to drain into. Swap out regularly until evaporation of case is complete (or until power is restored). <p>When power to case is restored, evaporator pan should function properly and water will no longer overflow onto flooring.</p>
	<p>Wicking material may be dirty or worn and need replacement (Hot Gas Evaporator system wicking material).</p> <ul style="list-style-type: none"> • Slide refrigeration system out from under unit. • After refrigeration system has been carefully slid out from under unit, replace wicking material with new. If wicking material is not available, contact Structural Concepts®. See toll-free number at last page of this operating manual.

CONDITION	TROUBLESHOOTING
Fan Emits Excessive Noise	Check that the case is aligned, level and plumb.
	Check evaporator fan for cleanliness.
	Unplug fan motors; check motor shaft for excessive bearing wear.
	Check that fan motors are securely mounted in brackets.
	Verify that fan blades are securely mounted to fan motor.
	Check that nothing is preventing blade rotation.
	Check that the fan shroud is properly secured.
Fans Are Not Working	Check that the MAIN power switch (if present) is on.
	Check that fans are plugged in to fan shroud.
	Check for foreign material obstructing fan performance.
	Check that fan blades freely rotate within fan shrouds.
	Check that power is going to fans.
	Check that fan wiring is connected on terminal blocks.
System Is Not Operating	Check that the utility power is on.
	Check the circuit breaker box for tripped circuits.
Case Is Not Holding Temperature	If a large amount of warm product was added to the case, it will take time for the temperature to adjust. Product should be pre-chilled before placing in display case.
	Check Temperature Controller section in this manual.
	Check that the case is not in the sun or near a heat or air conditioning vent.
	If case is located near outside doors, temperature fluctuation can hinder unit's ability to maintain temperature.
	Check air grilles for obstructions. Maintain airflow clearance of 6" (minimum) to 12" (recommended) at case front and rear.
	Check sight glass for flashing and/or low charge.
	Check Set Point Temperature; it may be adjusted too high.

CONDITION	TROUBLESHOOTING
Case Lights Are Not Working	Check that Light switch is in the ON position (self-contained cases only). Remote case lights come on at start-up.
	Check for burned out bulbs. Turn lights off & replace.
	Clean dirt and dust from the bulbs to prevent flickering.
	Check to insure voltage at ballasts. If voltage is entering but not exiting the ballast, ballast is faulty.
	Check that ALL lights are plugged in and receptacles capped.
	LED lights only: Check that plug is properly plugged into LED light. See MAINTENANCE FUNDAMENTALS - LED LIGHT FIXTURES section in this manual for illustrations.
Control Display Is Flashing	Check Temperature Controller section in this manual.
Condensing Unit Is Not Operating (Self-Contained Units Only)	Check Temperature Controller section in this manual.
	Check that the power is turned on.
	Review Temperature Controller's Settings for accuracy.

TROUBLESHOOTING - CONDENSING SYSTEM (QUALIFIED SERVICE TECHNICIANS ONLY)

CONDITION	TROUBLESHOOTING
Head Pressure Too High	Check that the Condensing Coil is not dirty or covered.
	Check that Condensing Fans are working.
	Check that the refrigeration system is not overcharged.
	Check that case is free of non-condensables.
	Check that the Liquid Line Drier Filter is not plugged.
	Check Set Point temperature; it may be adjusted too high.
	Check System Operating temperatures.
	Check that Store Ambient temperature isn't above maximum allowed. See <i>Overview and Warnings</i> Section.
Head Pressure Too Low	Check that Refrigerant Charge isn't too low.
	Check that Suction Pressure isn't too low.
	Check to verify that Compressor Valves aren't faulty.

TROUBLESHOOTING - EVAPORATOR SYSTEM (QUALIFIED SERVICE TECHNICIANS ONLY)

CONDITION	TROUBLESHOOTING
Low Suction Pressure	Check for low refrigerant.
	Check that Expansion Valve isn't restricted.
	Check that Liquid Line or Filter isn't restricted.
	Check that Evaporator Motors are working.
	Check for Superheat setting.
	Check that the Thermostatic Element charge isn't depleted.
	Check that the Coil is not iced up.
High Suction Pressure	Check that Refrigerant Charge isn't too high.
	Check that Compressor Valves aren't faulty.
	Check that there is no air seepage around Condensing Coil.
	Check that the Cooling Load isn't high.
	Check that Superheat adjustment isn't low.
	Check TXV Bulb Installation a. Poor thermal contact. b. Warm location.
	Check Compressor: Low capacity means it is undersized for its application.

PREVENTIVE MAINTENANCE (TO BE PERFORMED BY TRAINED SERVICE PROVIDER)

WARNING! TURN OFF CASE BEFORE PERFORMING PREVENTIVE MAINTENANCE!

PREVENTIVE MAINTENANCE	FREQUENCY	INSTRUCTIONS
Case Exterior	Monthly	<p><u>Condensing Coil:</u> <i>Note:</i> The vacuum 'blow mode' is to be used when cleaning the condenser coil. Follow these steps:</p> <ol style="list-style-type: none"> Remove grille; use vacuum and brush to dislodge and remove dust on and in coil. Place damp rags around condensing fan motor brackets to collect airborne dust. Using vacuum (in 'blowing' mode), blow air through condenser coils and into fans. Make certain to blow entire surface of condensing coils to assure that all entrenched dust is removed. Caution! Coil fins are sharp. Handle with care! Replace Rear Grille to case (4 screws).
	Quarterly	<p><u>Evaporator Pan [Electric Coil]:</u> <i>Caution! Disconnect power from receptacle box.</i></p> <ul style="list-style-type: none"> Remove mounting screws from base. Use de-scaling solution (such as CLR® that will prevent corrosion, lime and rust) to clean pan. Rinse thoroughly; do not submerge in water. Reattach pan to case with same mounting screws. Reconnect power cord to receptacle box.
		<p><u>Evaporator Pan [Hot Gas Evaporator Coil Units in EnergyWise]:</u> <i>Caution! Turn off power and allow to cool before cleaning!</i></p> <ul style="list-style-type: none"> Remove Grille / Front Panel (by removing 2 screws). Slide out Refrigeration Assembly. <i>Note:</i> At initial slide-out, it may be necessary to remove two (2) Compressor Pan Shipment Screws for Refrigeration Assembly to slide out. Use a clean cloth and hot water with soap solution to wipe down all the dust and residue that may form on parts. For Hot Gas Coils and Pans (including overflow Pan), use clean cloth and warm water with CLR® (to prevent calcium, lime and rust from forming). After Hot Gas Coils and Pans are thoroughly cleaned, rinse thoroughly with a spray bottle filled with clean water and a sponge to absorb remaining residue. Slide Refrigeration Unit Assembly back under case. Replace Rear Grille to case (2 screws).

PREVENTIVE MAINTENANCE (TO BE PERFORMED BY TRAINED SERVICE PROVIDER), CONT'D

WARNING! TURN OFF CASE BEFORE PERFORMING PREVENTIVE MAINTENANCE!

PREVENTIVE MAINTENANCE	FREQUENCY	INSTRUCTIONS
Case Exterior, Continued	Quarterly	<p><u>Compressor Area:</u> <i>Caution! Be certain to disconnect power from case before cleaning Compressor Area!</i></p> <ul style="list-style-type: none"> • Slide/Roll compressor package out from under case. • Use moist cloth to wipe off dust & debris that collects on various parts. • Slide/Roll compressor package back under case.
	Quarterly	<p><u>Under Case Cleaning:</u> Once refrigeration package is clear of unit, vacuum under case to remove all dust and dirt that may collect under case.</p>
Case Interior	Quarterly	<p><u>Tub, Coil, Drain, Fan Blades, Motors, Brackets:</u> <i>Disconnect power from the case before cleaning the Tub, Coil, Fan, Motor and Drain Area!</i></p> <ul style="list-style-type: none"> • Remove Decking, Sub-Deck and Fan Shroud. • Use vacuum to clean Evaporator Coils. • Clean Tub, Coil and Drain with warm water, clean cloth, brush and mild soap solution. • Remove any debris that may clog drain. • Clean Fan Blades, Motors and Brackets by wiping down with moist cloth.

Serial Label Location & Information Listed / Technical Information & Service

- Serial labels are located near the electrical access on your case.
- Serial labels contain electrical, temperature & refrigeration information, as well as regulatory standards to which the case conforms.
- For additional technical information and service, see the *TECHNICAL SERVICE* page in this manual for instructions on contacting Structural Concepts' Technical Service Department.
- See images below for samples of both refrigerated and non-refrigerated serial labels.





888 E. Porter Rd · Muskegon, MI 49441

ENCORE[®] MODEL HV74RSS SCROLL
SERIES SERIAL NO.

FOR PARTS AND SERVICE
CALL 1-800-433-9489

SAMPLE ONLY

  3048256 CONFORMS TO UL STD 471 CONFORMS TO NSF STD 7 CERTIFIED TO CAN/CSA STD C22.2 NO 120	ELECTRICAL RATING REFRIGERANT DESIGN PRESSURE MINIMUM CIRCUIT MAXIMUM OVERCURRENT	120/1/60 24A R404A AMOUNT ?? OZ HIGH 450 LOW 200 30A 30A
-------------------------------------------------------------------------------------------------------------------------------------------------------------------------------------------------------------------------------------------------------------------------------	-----------------------------------------------------------------------------------------------	----------------------------------------------------------------------

SAMPLE ONLY

Super Heat Temp	8-10°F
BTUH Requirements	9,738 BTUH @ 20° F SST
Defrost	6 defrosts per day, 45° F termination, 45 min. failsafe

SAMPLE ONLY

----- Sample Serial Label For Refrigerated Case -----



888 E. Porter Rd · Muskegon, MI 49441

Addenda[®] PC5682 txtRemote
txtSerialNumber

120 VOLTS 60 HZ SINGLE PHASE 1.84AMP

FOR PARTS OR SERVICE CALL
STRUCTURAL CONCEPTS
AT
1-800-433-9489

SAMPLE ONLY

UL

UL

3048256
CONFORMS TO UL STD 65
CERTIFIED TO CAN/CSA
STD C22.2 NO 120

----- Sample Serial Label For Non-Refrigerated Case -----

CAREL

ir33 platform

Integrated Electronic
Microprocessor Controller



Programming The Instrument

To Modify The Setpoint

Set Press and hold the "SET" key for at least 1 second.

▲/aux **def/▼** 2. Use arrow keys ▲ ▼ on temperature controller to increase (or decrease) the setpoint.

Set 3. Quickly press and release the "SET" key again.

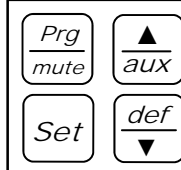

To Modify Defrost, Differential, Other Parameters

Prg/mute **Set** 1. Press & hold "Prg" & "SET" keys together for five (5) seconds; display will flash "0", representing password prompt.

Set 2. Confirm by pressing "SET" key.

▲/aux **def/▼** 3. Press ▲ or ▼ to reach the category to be modified.

Set 4. Press "SET" to modify this selected parameter.

▲/aux **def/▼** 5. Increase or decrease the value using the ▲ or ▼ button respectively.

Set 6. Press the "SET" key to temporarily save the new value and return to the display of the parameter.

Prg/mute 7. Press & hold the "Prg" key for at least 5 seconds to save changes. This action will also mute the audible alarm (buzzer) & deactivate the alarm relay.

How To Change Reading From Fahrenheit (°F) To Celsius (°C)

Prg/mute **Set** 1. Press and hold "Prg" and "SET" keys together for at least 5 seconds; display will show "0" (password prompt).

Set 2. Confirm by pressing "SET" key.

▲/aux **def/▼** 3. Press ▲ or ▼ until reaching the parameter "/ 5".

Set 4. Press "SET" to modify this selected parameter.

▲/aux **def/▼** 5. Press ▲ or ▼ to change value to desired setting: "0" for Celsius (°C) or "1" for Fahrenheit (°F).

Set 6. Press "SET" key to temporarily save the new value and return to the display of the parameter.

Prg/mute 7. Press & hold "Prg" key for at least 5 seconds to save changes. **Note! All values will automatically convert to new scale. No conversion is required.**

Warning! Save Your Parameter Settings!

1. To store the new parameter values, PRESS and HOLD the "Prg" key for at least 5 seconds.
2. All modifications made to parameters will be lost if you do NOT press a button within 60 seconds. Should this "timeout" occur, normal operational settings (prior to modifications being made) will resume.
3. If the instrument is switched off before pressing the "Prg" key, all modifications to parameters will be lost.

def/▼ **To Activate Manual Defrost**
Press and hold "def" key for at least 5 seconds.

▲/aux **To Activate / Deactivate Auxiliary Output**
Press and hold the "aux" key for 1 second.

Prg/mute **▲/aux** **To Reset Any Alarms With Manual Reset**
Press and hold the "Prg" and "aux" key for at least 1 second.

CAREL

ir33 platform
**Integrated Electronic
 Microprocessor Controller**



User Interface - Display

ICON	FUNCTION	DESCRIPTION	Normal operation			Start up
			ON	OFF	BLINK	
	COMPRESSOR	ON when the compressor starts. Flashes when the activation of the compressor is delayed by safety times.	Compressor on	Compressor off	awaiting activation	
	FAN	ON when the fan starts. Flashes when the activation of the fan is prevented due to external disabling or procedures in progress.	Fan on	Fan off	awaiting activation	
	DEFROST	ON when the defrost is activated. Flashes when the activation of the defrost is prevented due to external disabling or procedures in progress.	Defrost in progress	Defrost not in progress	awaiting activation	
	AUX	Flashes if the anti-sweat heater function is active, ON when the auxiliary output (1 and/or 2) selected as AUX (or LIGHT in firmware version 3.6) is activated.	AUX auxiliary output active (version 3.6 light auxiliary output active)	AUX auxiliary output not active	Anti-sweat heater function active	
	ALARM	ON following pre-activation of the delayed external digital input alarm. Flashes in the event of alarms during normal operation (e.g. high/low temperature) or in the event of alarms from an immediate or delayed external digital input.	Delayed external alarm (before the time 'A7' elapses)	No alarm present	Alarms in norm. operation (e.g. High/low temperature) or immediate or delayed alarm from external digital input	
	CLOCK	ON if at least one timed defrost has been set. At start-up, comes ON for a few seconds to indicate that the Real Time Clock is fitted.	If at least 1 timed defrost event has been set	No timed defrost event set	Alarm clock	ON if real-time clock present
	LIGHT	Flashes if the anti-sweat heater function is active, ON when the auxiliary output (1 and/or 2) selected as LIGHT is activated (in firmware version 3.6 it does not flash in anti-sweat heater mode and comes on when the dead band output is active).	Light auxiliary output on (version 3.6 dead band auxiliary output active)	Light auxiliary output off	Anti-sweat heater function active (version 3.6 does not flash in anti-sweat heater mode)	
	SERVICE	Flashes in the event of malfunctions, for example E2PROM errors or probe faults.		No malfunction	Malfunction (e.g. E2PROM error or probe fault). Contact service	
	CONTINUOUS CYCLE	ON when the CONTINUOUS CYCLE function is activated. Flashes if the activation of the function is prevented due to external disabling or procedures in progress (E.g.: minimum compressor OFF time).	CONTINUOUS CYCLE operation activated	CONTINUOUS CYCLE function not activated	CONTINUOUS CYCLE operation requested	

Summary Table of Alarm and Signals: Display, Buzzer and Relay

Code	Icon on the display	Alarm relay	Buzzer	Reset	Description
rE	flashing	on	on	automatic	virtual control probe fault
E0	flashing	off	off	automatic	room probe S1 fault
E1	flashing	off	off	automatic	defrost probe S2 fault
E2	flashing	off	off	automatic	probe S3 fault
E3	flashing	off	off	automatic	probe S4 fault
E4	flashing	off	off	automatic	probe S5 fault
	No	off	off	automatic	probe not enabled
LO	flashing	on	on	automatic	low temperature alarm
HI	flashing	on	on	automatic	high temperature alarm
AFr	flashing	on	on	manual	antifreeze alarm
IA	flashing	on	on	automatic	immediate alarm from external contact
dA	flashing	on	on	automatic	delayed alarm from external contact
dEF	on	off	off	automatic	defrost running
Ed1	No	off	off	automatic/manual	defrost on evaporator 1 ended by timeout
Ed2	No	off	off	automatic/manual	defrost on evaporator 2 ended by timeout
Pd	flashing	on	on	automatic/manual	maximum pump down time alarm
LP	flashing	on	on	automatic/manual	low pressure alarm
AtS	flashing	on	on	automatic/manual	autostart in pump down
cht	No	off	off	automatic/manual	high condenser temperature pre-alarm
CHT	flashing	on	on	manual	high condenser temperature alarm
dor	flashing	on	on	automatic	door open too long alarm
EE	flashing	off	off	automatic	E2prom error, unit parameters
EF	flashing	off	off	automatic	E2prom error, operating parameters
ccb	Signal				start continuous cycle request
ccE	Signal				end continuous cycle request
dFb	Signal				start defrost call
dFE	Signal				end defrost call
On	Signal				switch ON
off	Signal				switch OFF
rES	Signal				reset alarms w/manual reset / reset HACCP alarms / reset temp. monitoring

CAREL

ir33 platform

Integrated Electronic
Microprocessor Controller



Summary Table of Operating Parameters

CODE	PARAMETER	UOM*	TYPE	MINIMUM	MAXIMUM	DEFAULT
/5	Select Celsius (°C) or Fahrenheit (°F)	flag	C	0	1	For Case Specific Defaults See Serial Label Located Near Electrical Access On Your Case. For Additional Technical Information Call Structural Concepts Technical Service Dept. at 1(800) 433.9489
/c1	Calibration of probe 1	°C/°F	C	-20	20	
/c2	Calibration of probe 2	°C/°F	C	-20	20	
St	Temperature set point	°C/°F	F	r2	r1	
rd	Control delta	°C/°F	F	20	0.1	
dl	Interval between defrosts	hours	F	0	250	
dt1	End defrost temperature, evaporator	°C/°F	F	-50	200	
dP1	Maximum defrost duration, evaporator	min	F	1	250	
d6	Display on hold during defrost	-	C	0	2	
dd	Dripping time after defrost	min	F	0	15	
d/1	Display of defrost probe 1	°C/°F	F	-	-	

* Unit Of Measure

Controller Overview: The CPC® ESC3 series is an electronic refrigeration controller that provides control of compressor, fan and defrost management. The ESC3 provides control of a compressor (or solenoid) valve in response to temperature variations.



Temperature Control: Temperature control in the ESC3 is accomplished by comparing the temperature reading of case temperature probe against temperature set point. Compressor output is used to control temperature. If temperature is above temperature set point (LI) + the hysteresis set point (rd), compressor output is turned on. If the temperature is below temperature set point (L1) - the hysteresis set point (rd), compressor output is turned off.

Compressor Control: Several set points are available to allow operation of compressor output to be tailored to match individual needs.

Min ON/Off Times and Minimum Cycle Time: Minimum ON/OFF compressor times can be specified, as well as a minimum time delay between compressor cycles. These parameters help prevent short cycling.

Compressor Power On Delay: Compressor power on delay setpoint (c0) allows user to specify a delay after power-up of the controller. The compressor output will not come on regardless of the temperature reading until this amount of time has expired.

Compressor Safety Cycle: The Compressor Safety Cycle setpoint (c4) specifies a cycle time that the compressor is to be cycled if the temperature sensor used for control fails. If this set point is 0, the compressor will be off. If this setpoint is 100, the compressor will be on. Any value between 1 and 99 will result in the compressor being on for that period of time. At the end of this time, the compressor will be shut off for approximately 15 minutes.

Interface: The ESC3 features a 3 digit LED displaying supply air temperature. Supply air temperature will always be cooler than actual case temperature. For actual case temperature, see internal case thermometer. The temperature can be displayed in either °C or °F.

 **Alarm Key** - The Alarm key illuminates when the controller has detected an alarm condition. This key is also used to reset an alarm condition and to enter the setup mode (allowing the set points to be changed).

 **Compressor Key** - The Compressor key illuminates when compressor output is on. When ESC3 is in setup mode, this key is used to select a set point to be modified and to change set point value.

 **Defrost Key** - The Defrost key illuminates when the ESC3 is in defrost mode. Press the defrost key for 5 seconds to go into manual defrost mode. The key is also used in setup mode to select a set point to be modified and to change the value of the set point.

Alarm Operation - The ESC3 has several alarm functions. In addition to alarms based on air temperatures, it will alarm if a probe failure is detected.

Indications on the Display: If the “defrost” or “compressor” key blinks, the corresponding function is delayed by a timing routine or is inhibited.

Code Chart: See next page.

Viewing and Changing the Temperature Set Point

The temperature set point is the comparison point for the control temperature input. To change the set point value:

1. Press the Alarm key for 3 seconds, until the set point is displayed and blinking.
2. Press compressor key or defrost key to raise/lower value.
3. Press the Alarm key again to accept the new value.



Changing Other Parameter Settings

There are two levels of factory set point parameter settings in the ESC3.

1. The first level does not require a password to change (unless the buttons are locked out). It is identified by CPC® as “User Level Set Points”. *Note: These default settings can be obtained from OEM upon request.*
2. The second level does require a password to change and is identified by CPC® as “OEM Level Set Points”. *Note: These default settings can be obtained from OEM upon request.*

To change USER parameters:

1. Press the alarm key and hold it until the letters PS are displayed.
2. Use the compressor and defrost keys to scroll through the different parameters.
3. When the code is displayed for the set point you wish to change, press the alarm key. The value for that set point will be displayed.
4. Press the compressor or defrost key to change the value.
5. Press the alarm key to go back to the code.

At this point you must press the alarm key (for approximately 6 seconds) to accept the change or press the compressor or defrost key to scroll to the next USER set point. To accept the changes, press and hold the alarm key until the display stops flashing.

Code	Meaning
E0	Air probe has failed.
E1	Defrost termination or product probe has failed.
L0	Low temperature alarm.
HI	High temperature alarm.
Ed	Defrost timeout has occurred (did not terminate correctly).
dF	Controller is in defrost mode (not and alarm).

STRUCTURAL CONCEPTS CORPORATION TECHNICAL SERVICE
PHONE NUMBER: 1.800.433.9489 or For Your Master Service Agent See
WWW.STRUCTURALCONCEPTS.COM/Contact/Master_Service_Agents.asp

LIMITED WARRANTY

All sales by Structural Concepts Corporation (SCC) are subject to the following limited warranty. "Goods" refers to the product or products being sold by SCC.

Warranty Scope: Warranty is for equipment sold in the United States, Canada, Mexico and Puerto Rico. Equipment sold elsewhere may carry modified warranty.

Warranty; Remedies; Limitations. SCC warrants that if any Goods are found by an authorized representative of SCC not to be of good material or workmanship within one year of the date of shipments SCC will, at its option after inspection by an authorized representative, replace any defective Good or pay the reasonable cost of replacement for any such defective Goods, provided that written notice of the defect is given to SCC within 30 days of the appearance of such defect. If notice is not given within such period, any claim for breach of warranty shall be conclusively deemed to have been waived and SCC shall not be liable under this warranty. If SCC is unable to repair or replace the defective Goods, SCC shall issue a credit to the Purchaser for all or part of the purchase price, as SCC shall determine. The replacement or payment in the manner described above shall be the sole and exclusive remedy of Purchaser for a breach of this warranty. If any Goods are defective or fail to conform to this warranty, SCC will furnish instructions for their disposition. No Goods shall be returned to SCC without its prior consent.

SCC's liability for any defect in the Goods shall not exceed the purchase price of the Goods. SCC SHALL HAVE NO LIABILITY TO PURCHASE FOR CONSEQUENTIAL DAMAGES OF ANY KIND WHATSOEVER, INCLUDING, BUT NOT LIMITED TO, PERSONAL INJURY, PROPERTY DAMAGE, LOST PROFITS, OR OTHER ECONOMIC INJURY DUE TO ANY DEFECT IN THE GOODS OR ANY BREACH OF SCC, SCC SHALL NOT BE LIABLE TO THE PURCHASER IN TORT FOR ANY NEGLIGENT DESIGN OR MANUFACTURE OF THE GOODS, OR FOR THE OMISSION OF ANY WARNING THEREFROM.

SCC shall have no obligation or liability under this warranty for claims arising from any other party's (including Purchaser's) negligence or misuse of the Goods or environmental conditions. This warranty does not apply to any claim or damage arising for or cause by improper storage, handling, installation, maintenance, or from fire, flood, accidents, structural defects, building settlement or movement, acts of God, or other causes beyond SCC's control.

Except as expressly stated herein, SCC makes no warranty, express, implied, statutory or otherwise as to any parts or goods not manufactured by SCC. SCC shall warrant such parts or Goods only (I) against such defects, (II) for such periods of time, and (III) with such remedies, as are expressly warranted by the manufacturer of such parts of Goods. Notwithstanding the foregoing, any warranty with respect to such parts of Goods and any remedies available as a result of a breach thereof shall be subject to all of the procedures, limitations, and exclusions set forth herein.

THE WARRANTIES HEREIN ARE IN LIEU OF ALL WARRANTIES, EXPRESS, IMPLIED, STATUTORY, OR OTHERWISE. IN PARTICULAR, SCC MAKES NO WARRANTY OF MERCHANTABILITY OR FITNESS FOR A PARTICULAR PURPOSE.

No representative, agent or dealer of SCC has authority to modify, expand, or extend this Warranty, to waive any of the limitations or exclusions, or to make any different or additional warranties with respect to Goods.

Period of Limitations. No claim, suit or other proceeding may be brought by Purchaser for any breach of the foregoing warranty or this Agreement by SCC or in any way arising out of this Agreement or relating to the Goods after one year from the date of the breach. In the interpretation of this limitation on action for a breach by SCC, it is expressly agreed that there are no warranties of future performance of the goods that would extend that period of limitation herein contained for bringing an action.

Indemnifications. Purchaser agrees to indemnify, hold harmless, and defend SCC if so requested, from any and all liabilities, as defined herein, suffered, or incurred by SCC as a result of, or in connection with, any act, omission, or use of the Goods by Purchaser, its employees or customers, or any breach of this Agreement by Purchaser. Liabilities shall include all costs, claims, damages, judgments, and expenses (including reasonable attorney fees and costs).

Remedies of SCC. SCC's rights and remedies shall be cumulative and may be exercised from time to time. In a proceeding or action relating to the breach of this Agreement by Purchaser, Purchaser shall reimburse SCC for reasonable costs and attorney's fees incurred by SCC. No waiver by SCC of any breach of Purchaser shall be effective unless in writing nor operate as a waiver of any other breach of the same term thereafter. SCC shall not lose any right because it has not exercised it in the past.

Applicable Law. This Agreement is made in Michigan and shall be governed by and interpreted according to Michigan law. Any lawsuit arising out of this Agreement or the Goods may be handled by a federal or state court whose district includes Muskegon County, Michigan, and Purchaser consents that such court shall have personal jurisdiction over Purchaser.

Miscellaneous. If any provision of this Agreement is found to be invalid or unenforceable under any law, the provision shall be ineffective to that extent and for the duration of the illegality, but the remaining provisions shall be unaffected. Purchaser shall not assign any of its rights nor delegate any of its obligations under this Agreement without prior written of SCC. This Agreement shall be binding upon and inure to the benefit of SCC and Purchaser and each of their legal representatives, successors and assigns.

SCC warrants its products to be free of defects in materials and workmanship under normal use and service for a period of one (1) year from the date of delivery.

This warranty is extended only to the original purchaser for use of the Goods. It does not cover normal wear parts such as plastic tongs, tong holders, tong cables, bag holders, or acrylic dividers.

General Conditions. All service labor and/or parts charges are subject to approval by SCC. Contact the Customer Service Department in writing or call 231-798-8888.

All claims must contain the following information: (1) model & serial code number of equipment; (2) the date and place of installation; (3) the name and address of the agency which performed the installation; (4) the date of the equipment failure; and (5) a complete description of the equipment failure and all circumstances relating to that failure.

Once the claim has been determined to be a true warranty claim by SCC's Customer Service Department, the following procedure will be taken: (1) replacement parts will be sent at no charge from SCC on a freight prepaid basis; (2) reimbursement for service labor will be paid if the following conditions have been met - (a) prior approval of service agency was awarded from the Customer Service Department; and (b) an itemized statement of all labor charges incurred is received by the Customer Service Department. The cost of the service labor reimbursement will be based on straight time rates and reasonable time for the repair of the defect.

If problems occur with any compressor, notify SCC's Customer Service Department immediately. Any attempt to repair or alter the unit without prior consent from the Customer Service Department will render any warranty claim null and void. This warranty and protection plan does not apply to any condensing unit or any part thereof which has been subject to accident, negligence, misuse, or abuse, or which has not been operated in accordance with the manufacturer's recommendations or if the serial number of the unit has been altered, defaced, or removed.

Limit of Liability. The limit of liability of SCC toward the exchange cost of the original condensing unit, F.O.B. SCC, Norton Shores, MI, of each motor-compressor assembly replaced during the warranty shall not exceed manufacturer's current established wholesaler's exchange price and in no case shall the labor of removing or replacing the motor-compressor or parts thereof be the responsibility of SCC.