

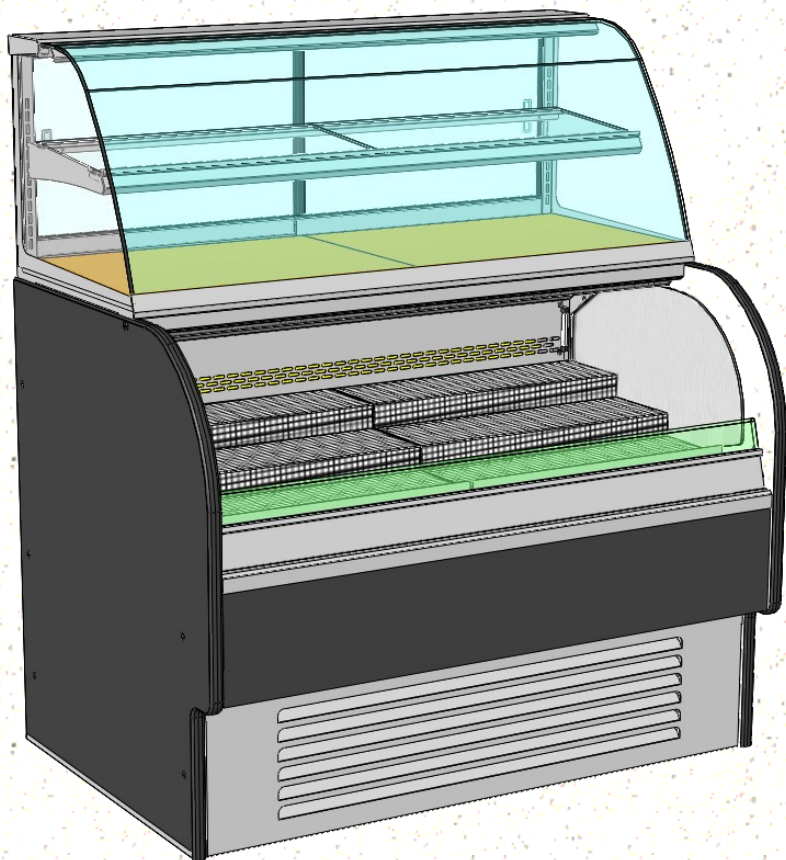

USER MANUAL

SCC P/N
20-35759

SELF-CONTAINED MERCHANDISERS
> REFRIGERATED SELF-SERVICE LOWER SECTION
> AMBIENT SERVICE UPPER SECTION



Model COU5057R.5854 (Shown With Customer-Supplied Front Panel)

Model
COU2765R

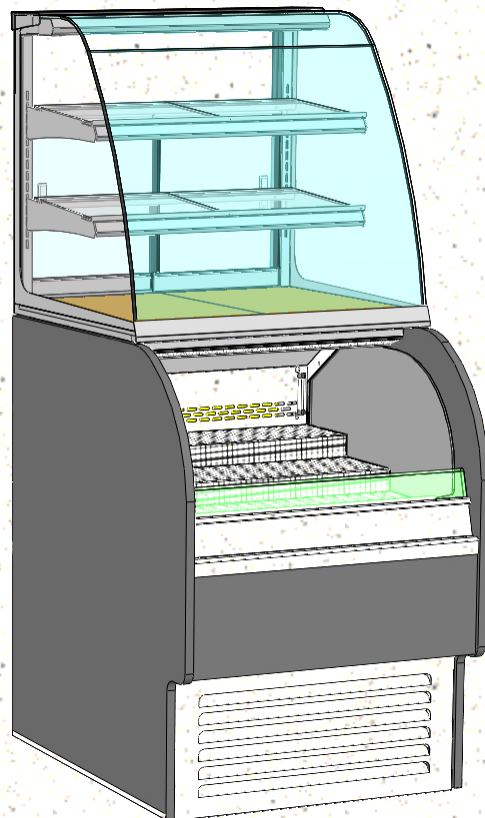

Model
COU2757R

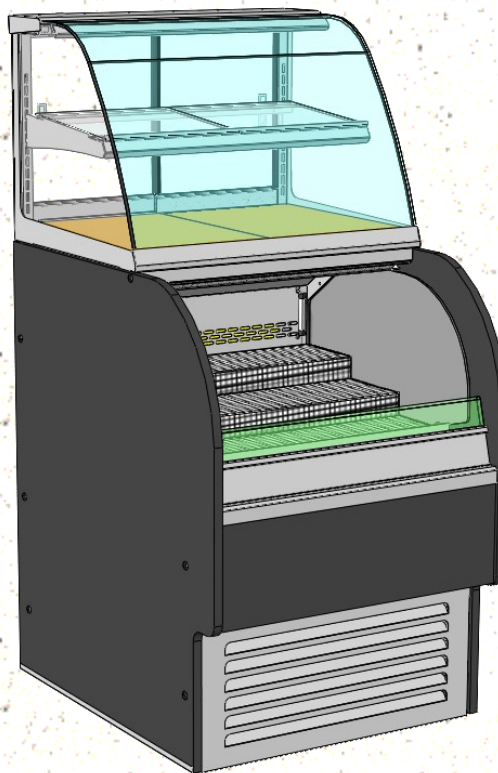

TABLE OF CONTENTS

OVERVIEW / TYPE / COMPLIANCE / WARNINGS / PRECAUTIONS / WIRING	3-4
POWER CORD CHANNEL / MERCHANDISER START-UP	5
MAINTENANCE FUNDAMENTALS - FRONT GRILLE / REAR DOORS / INTERIOR SHELVING / THERMOMETER	6
MAINTENANCE FUNDAMENTALS, CONT'D - LED STYLE LIGHT FIXTURES	7
MAINTENANCE FUNDAMENTALS, CONT'D - LOAD LINES / CONDENSER PACKAGE AIRFLOW	8
REAR ELECTRICAL COMPONENTS / FIELD ACCESS BOX / FIELD SENSOR	8
REFRIGERATION FUNDAMENTALS	9
EVAPORATOR FAN, FAN SHROUD, TXV, REFRIGERATION LINES ACCESS	10
GENERAL LAYOUT OF CONDENSER PACKAGE ON MODEL COU2757R.5853	11
GENERAL LAYOUT OF CONDENSER PACKAGE ON MODEL COU5057R.5854	12
CLEANING SCHEDULE (TO BE PERFORMED BY STORE PERSONNEL)	13
CLEANING SCHEDULE (TO BE PERFORMED BY TRAINED SERVICE PROVIDERS ONLY)	14
PREVENTIVE MAINTENANCE - HONEYCOMB AIR DIFFUSERS (TO BE PERFORMED BY TRAINED SVC. PROVIDERS ONLY)	15
TROUBLESHOOTING (TO BE PERFORMED BY STORE PERSONNEL)	16-17
TROUBLESHOOTING (TO BE PERFORMED BY TRAINED SERVICE PROVIDERS ONLY)	18-20
TROUBLESHOOTING (BY TRAINED SERVICE PROVIDERS ONLY) - CONDENSING SYSTEM	21
TROUBLESHOOTING (BY TRAINED SERVICE PROVIDERS ONLY) - EVAPORATOR SYSTEM ...	22
SERIAL LABEL LOCATION & INFORMATION LISTED / TECHNICAL INFO & SERVICE	23
CAREL® CONTROLLER - PROGRAMMING THE INSTRUMENT.....	24
CAREL® CONTROLLER - USER INTERFACE, SUMMARY TABLES OF ALARMS & SIGNALS	25
CAREL® CONTROLLER - Summary Table of Operating Parameters (After Programming Key) ..	26
STARBUCKS TECHNICAL SERVICE CONTACT INFORMATION & LIMITED WARRANTY	27

OVERVIEW

- These dual functional cases are designed to merchandise pre-chilled packaged bakery products at 3 °C / 38 °F or less (lower section) and at ambient temperatures (upper section).
- Cases should be installed and operated according to this operating manual's instructions to ensure proper performance.
- Improper use will void warranty.

TYPE I vs. TYPE II ENVIRONMENTAL CONDITIONS

This unit is designed for the display of products in ambient store conditions where temperature and humidity are maintained within a specific range.

- Type I display refrigerators are intended for use in an area where environmental conditions are controlled and maintained so that the ambient temperature does not exceed 75 °F (24 °C) and 55% maximum humidity.

- Type II display refrigerators are intended for use in an area where environmental conditions are controlled and maintained so that the ambient temperature does not exceed 80 °F (27 °C) and 60% maximum humidity.
- If unsure if your unit is Type I or II, see tag next to serial label. See **SERIAL LABEL LOCATION & INFORMATION LISTED / TECH INFO & SERVICE** section in this manual for sample serial labels.

COMPLIANCE

- Performance issues when in violation of applicable NEC, federal, state and local electrical and plumbing codes are not covered by warranty. See below.

WARNINGS

- This page contains important warnings to prevent injury or death.
- Please read carefully!



COMPLIANCE
 This equipment **MUST** be installed in compliance with all applicable NEC, federal, state and local electrical and plumbing codes.



WARNING
 Risk of electric shock. Disconnect power before servicing unit. **CAUTION!** More than one source of electrical supply is employed with units that have separate circuits. **Disconnect ALL ELECTRICAL SOURCES before servicing.**



WARNING
 Hazardous moving parts. Do not operate unit with covers removed. Fan blades may be exposed when deck panel is removed. Disconnect power before removing deck panel.



WARNING
 Condenser Pan is Hot!
 Disconnect or turn off unit and allow to cool before cleaning or removing from case.



WARNING: This product can expose you to chemicals, including Urethane (Ethyl Carbamate), which are known to the state of California to cause cancer and birth defects or other reproductive harm. For more information go to P65Warnings.ca.gov.

PRECAUTIONS

- Following are important precautions to prevent damage to unit or merchandise. Please read carefully!

WIRING DIAGRAM

- Each case has its own wiring diagram folded and in its own packet.
- Wiring diagram placement may vary; it may be placed near ballast box, field wiring box, raceway cover, or other related location.

REFRIGERANT DISCLOSURE STATEMENT

- This equipment is prohibited from use in California with any refrigerants on the “List of Prohibited Substances” for that specific end-use, in accordance with California Code of Regulations, title 17, section 95374.
- This disclosure statement has been reviewed and approved by Structural Concepts and Structural Concepts attests, under penalty of perjury, that these statements are true and accurate.



CAUTION! LAMP REPLACEMENT GUIDELINES
 LED lamps reflect specific size, shape and overall design. Any replacements must meet factory specifications.

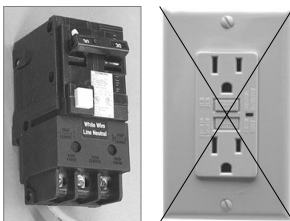

CAUTION! GFCI BREAKER USE RECOMMENDATION
 If N.E.C. (National Electric Code) or your local code requires GFCI (Ground Fault Circuit Interrupter) protection, the use of a GFCI breaker is strongly recommended.

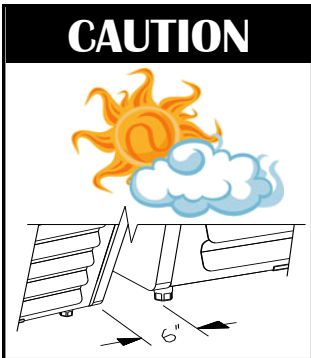

CAUTION! ADVERSE CONDITIONS / SPACING ISSUES

- Performance issues caused by adverse conditions are NOT warranted.
- To prevent damage to end panels due to condensation, apply industrial grade silicone sealant and tightly join to opposite end panels. When not adjoining cases, keep end panels at least 6” away from walls and structures. Rear panels must also be kept at least 6” from walls and structures.
- Case must not be exposed to direct sunlight or any heat source.
- To maintain proper case temperature, keep case at least 15-feet from exterior doors, overhead HVAC vents or any air curtain disruption.
- Self-contained case clearance: 6” min. air intake / 6” min. air discharge.



CAUTION! DO NOT RELY ON THERMOMETERS OR THERMOSTATS FOR PRODUCT (FOOD) TEMPERATURES.

- Thermometers & thermostats reflect air temperatures ONLY.
- For ACTUAL product (food) temperatures, use a calibrated food probe thermometers ONLY.
- For accurate readings, DO NOT use infrared food thermometers.

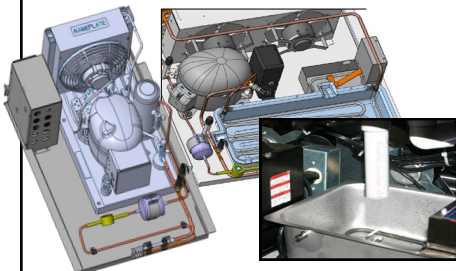

CAUTION! CHECK CONDENSATE PAN, ITS POSITION & PLUG!
 Water on flooring can cause extensive damage!

- Before powering up case, check that condensate pan is positioned directly under case’s condensate drain.
- Before powering up case, check that condensate pan’s electrical plug is SECURELY connected to condensate system’s receptacle.
- If wicking material is used in condensate pan, check that it is secure.

POWER CORD CHANNEL / MERCHANDISER START-UP

1. Power Cord Channel

- Depending upon outlet, power cord may need to be routed to opposite side of case.
- A channel is provided at case rear to assist in cord routing.
- See illustration at right.

2. Merchandiser Start-Up

- Do not use an extension cord with this unit.
- Do not operate this equipment with a damaged cord, plug or outlet.
- Insure the main power switch is off.
- Plug cord into a certified 110V electrical outlet with ground.
- Turn main power on.
 - Remove rear panel by removing 4 screws (as shown in illustration at right). Switch is on the right side of case.
- Coil fan should turn on.
 - From inside of the case, check for discharge air from front baffle, to confirm that the fans are functioning properly.
- When the case is in a start-up mode or has been idle for a long period of time, the unit will require 75-minutes running time to pull-down temperature.
- Turn lights on.
 - Light switch is a rocker type on the under right side of the top light.
 - The lights should come on at the same time.
- It is recommended that the **self-contained** refrigerated cases maintain front and rear airflow clearance of approximately twelve inches.
- Obstruction or restriction of air can void warranty.
- **Note:** Case temperature is set at the factory, as determined by case size.
- Temperature is controlled by a thermostat.
- If a temperature setting change is required, refer to the instructions for the temperature controller operating section of this manual.
- **Note:** See serial label on case for set point.

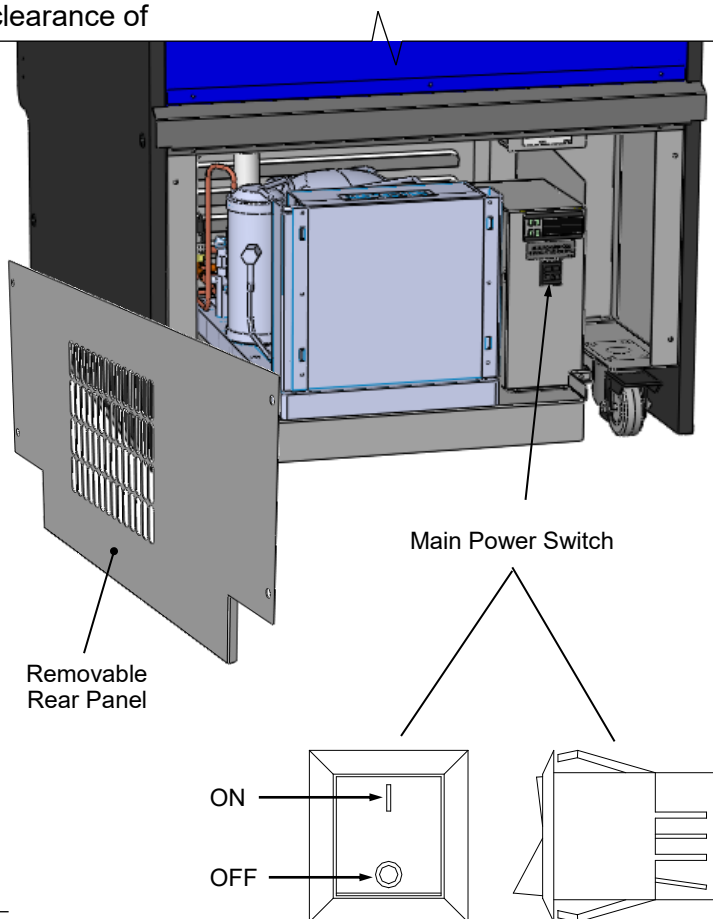
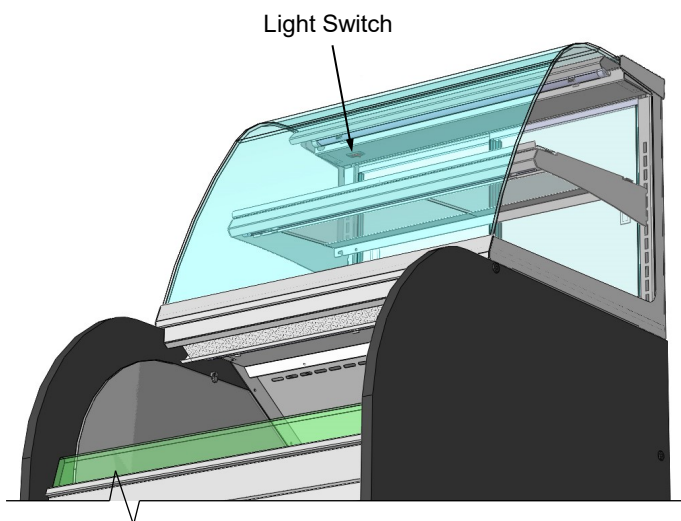
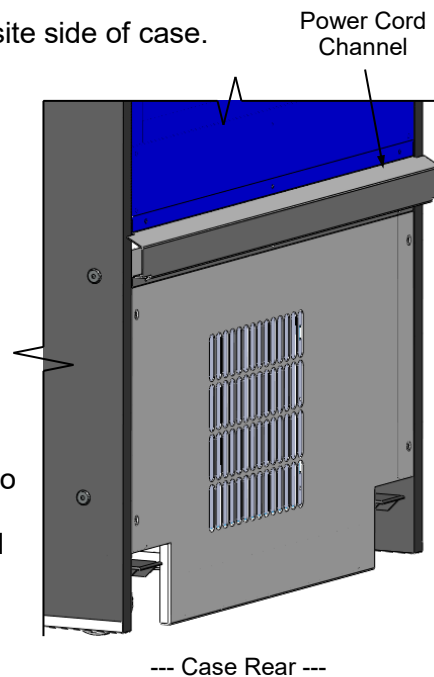

1. Removing Front Grille

- Lift front grille upward one-half inch to disengage a top support flange
- Simply pull away from case front and front grille is removed from merchandiser.

2. Removing Rear Doors

- Move rear doors toward the center of the case.
- Individually lift each door up toward the top of the case and pivot the bottom of the door out from track.

3. Removing Interior Shelving

- Remove the rear doors.
- Remove the glass shelving.
- Remove the rear shelf support from brackets.
- Disconnect shelf light from brackets and rotate to facilitate maintenance.
 - Note: Shelf light cannot be removed without being disassembled.
- Shelf brackets can not be removed.

4. Thermometer

- Spirit thermometer is located in the refrigerated compartment are for monitoring warmest air temperature.
- Probe must be used to determine actual product temperature.
- See illustration below-left.

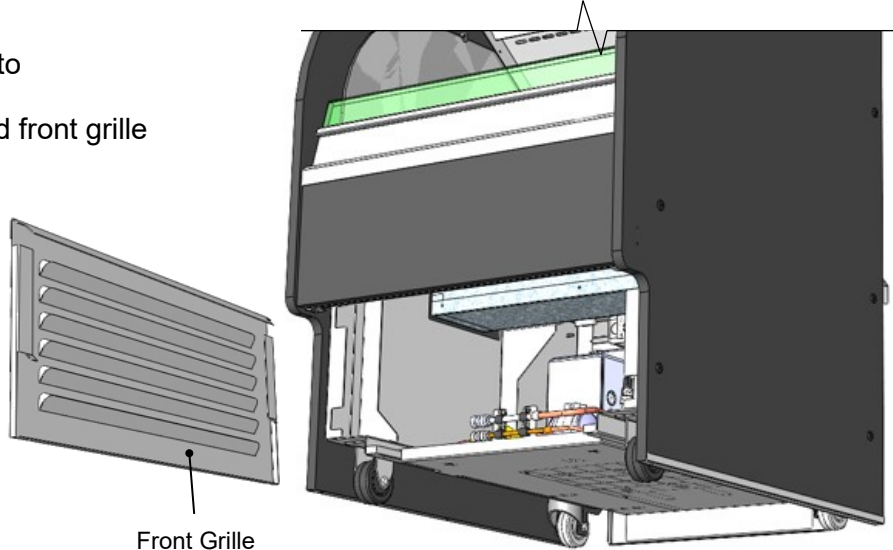

Front Grille

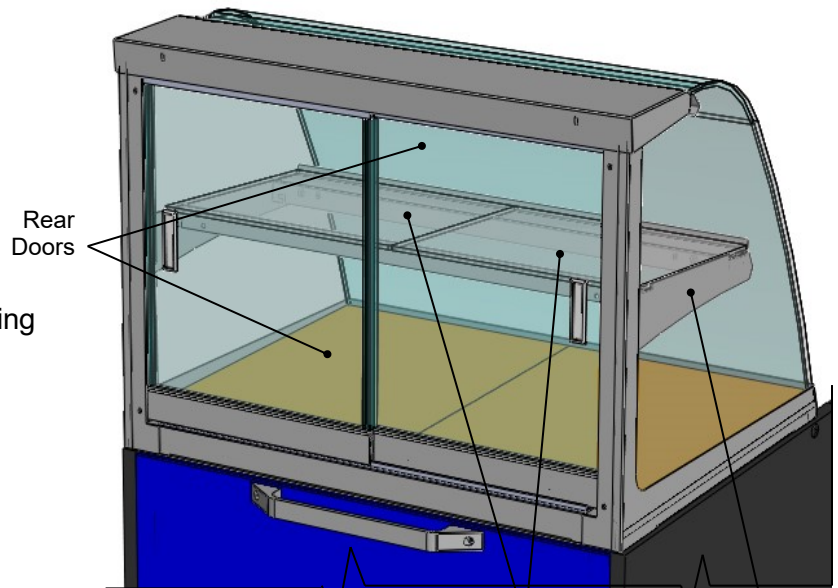

Rear Doors

Shelf Glass

Shelf Bracket

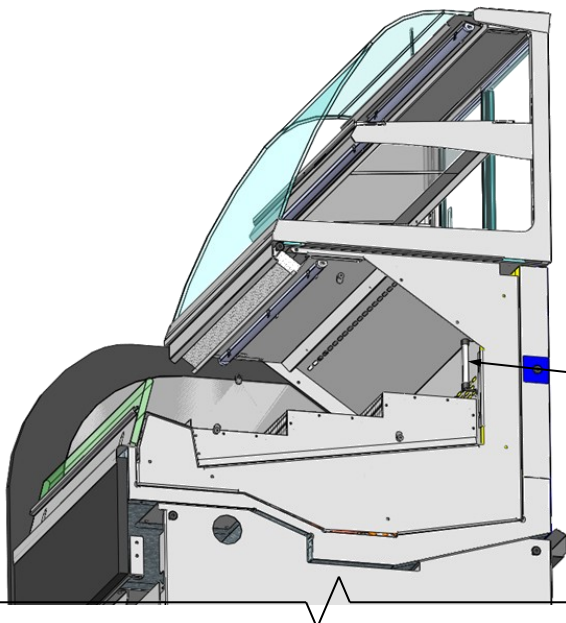

Spirit Thermometer

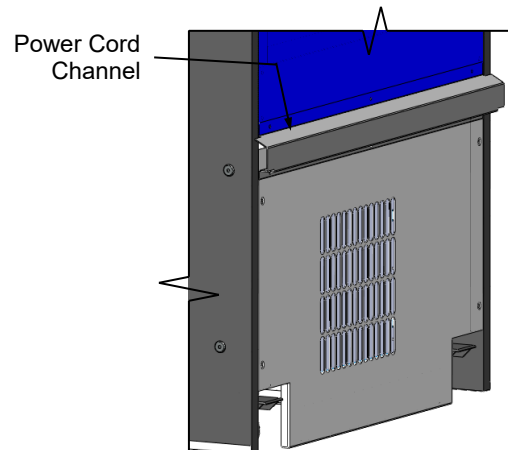

Power Cord Channel

5. LED Style Light Fixtures

Removal of Faulty LED Lights:

- Contact Structural Concepts' Technical Service Department for replacement LED lights.
- Turn off LED light switch.
- To remove faulty LED light, follow these steps:
 - A. Disconnect plug from LED light.
 - B. Using both hands, grasp LED light assembly (with its magnetic mounting clips). Pull downward and off its shelf (or header).
 - C. Remove magnetic mounting clips from LED light by pressing against flange part of clip with thumb.

>> **Note:** Mounting clips MAY be riveted to shelf or header. In such instances, simply remove LED light from mounting clips by pressing against flange part of clips with thumb.

Replacement of LED lights:

- Attach magnetic mounting clips onto LED light.
- Adjust magnetic mounting clips so they are equally spaced on LED light.
- Reattach LED light assembly to its shelf/header.
- Position properly in shelf/header.

>> **Note:** If mounting clips are riveted to shelf (or header), attach by placing LED in base of clip and then snapping into clip at FLANGE SIDE.

- Press plug's barrel-shaped insert deep into LED light.
- **Important:** If plug is not inserted ALL THE WAY IN the LED light's orifice, the light may not energize. See "**BAD**" vs. "**GOOD**" insertion illustrations below-right.
- Turn LED light switch back on.

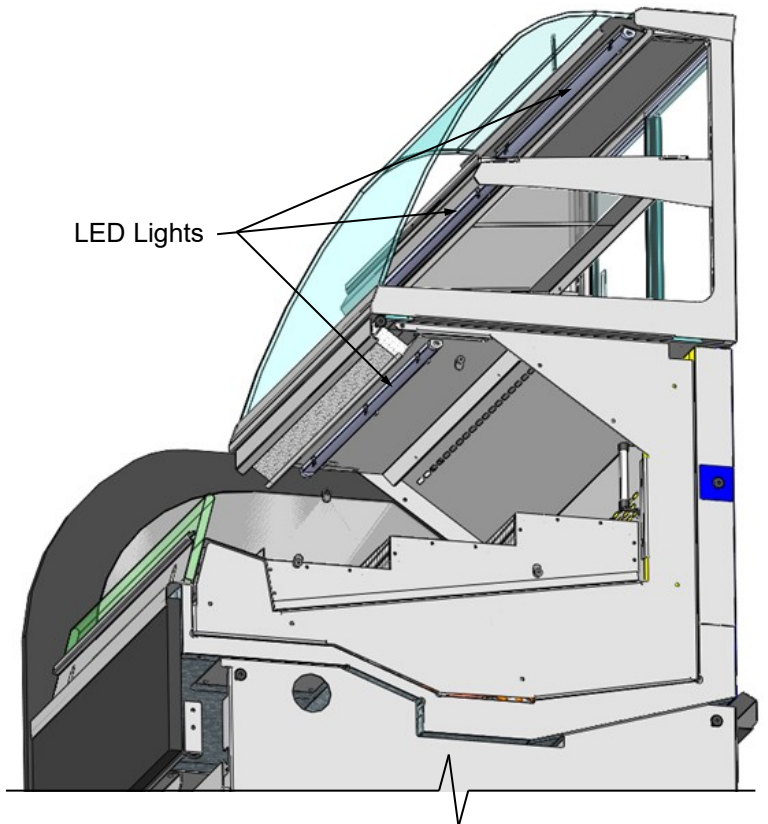
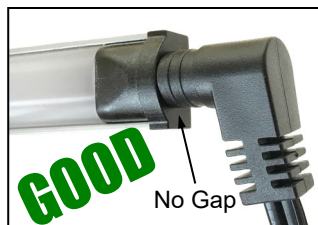
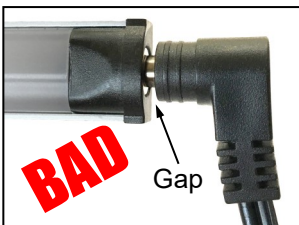
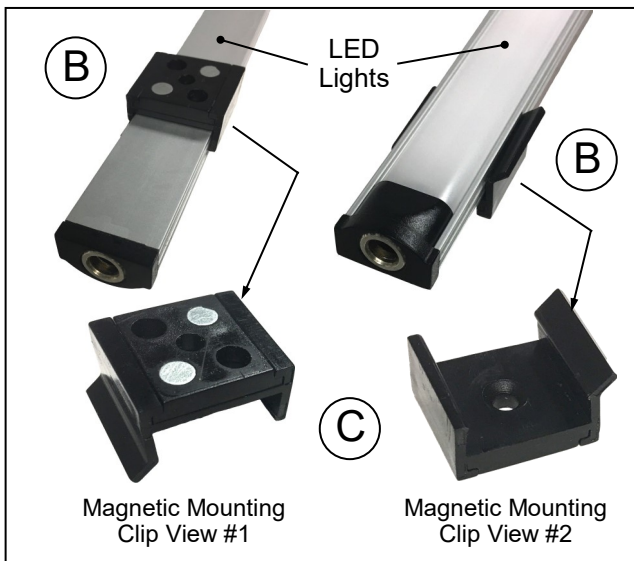
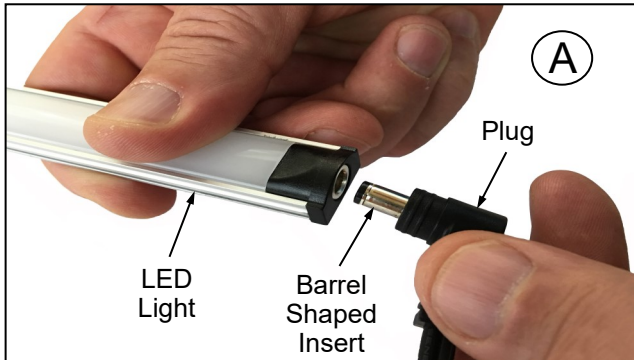

6. Load Lines

- Load lines represent the maximum product height AS WELL AS how near product can be placed near honeycomb air diffuser (and its air return duct).
- Keep product AT OR UNDER/BEHIND load lines to assure that refrigerated airflow is properly cycled.
- Proper product placement will maintain acceptable product temperature.
- See illustration below.

Model COU5057R.5854
Shown Partially
Disassembled For
Illustrative Purposes Only.

7. Condenser Package Airflow

- Air intake is at rear. Air outflow is at front.
- Do not block airflow areas.
- Keep at least 6" space between case rear and wall (or other obstruction).

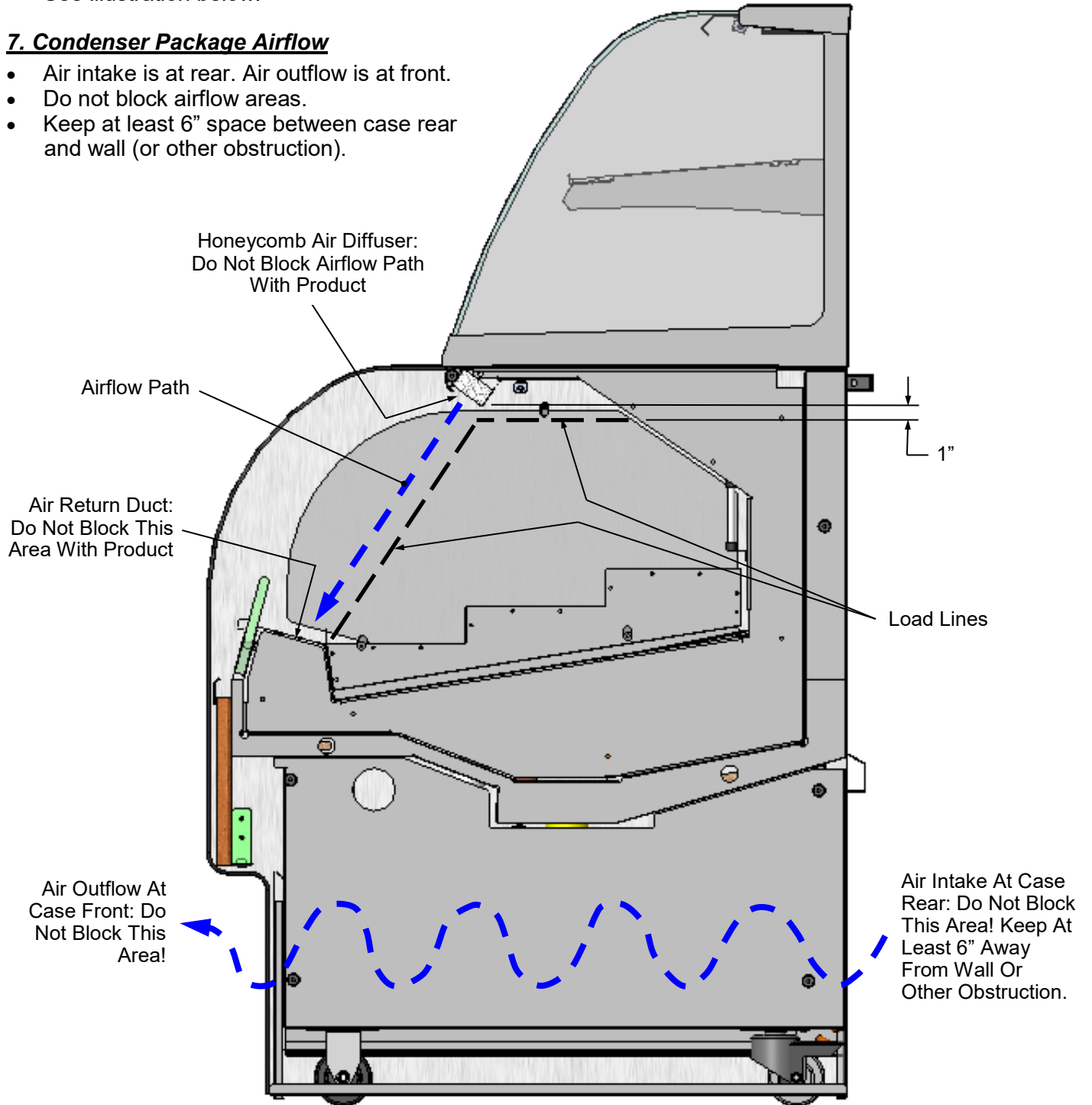

Rear Electrical Box Components / Field Access Box / Field Sensor

Warning, disconnect power before providing maintenance and service to unit.

Rear Electrical Box Access

- Remove rear panel (by removing 4 screws).
- Field access box, field sensor box temperature controller and main power switch is accessible.
- Carefully slide compressor pan out from under case to access electrical box side panel. Removal of 4 screws will allow side panel removal and access to electrical components.
- After performing cleaning, service and/or repair duties, slide compressor pan back under unit.
- Reattach rear panel to rear of case by attaching the four screws that had been removed.
- Case temperature is set at factory, as determined by the case size. Temperature is controlled by a thermostat. If a temperature setting change is required, follow the instructions for the **Carel® Controller** in the technical information section of this operating manual.

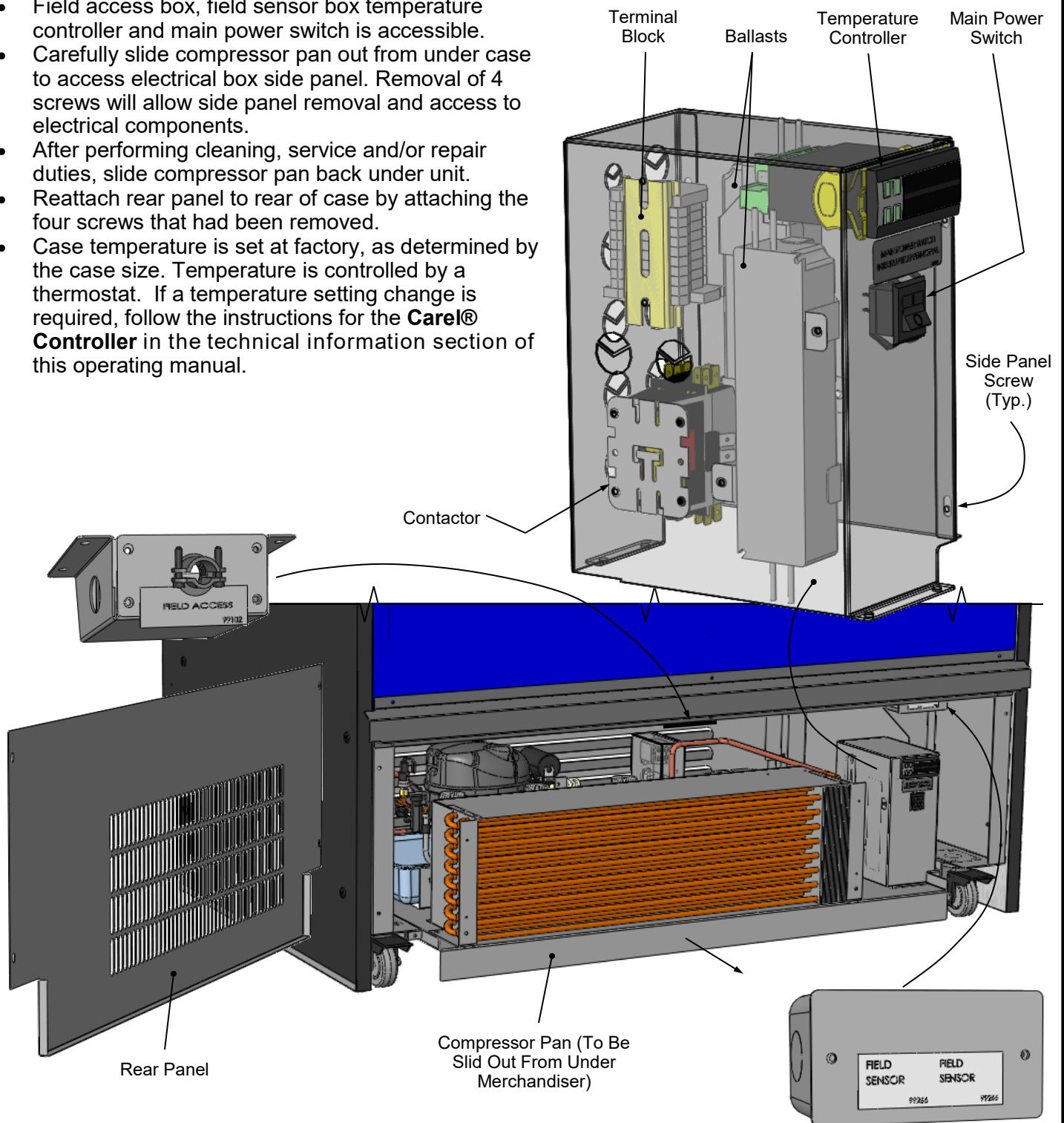

EVAPORATOR FAN, FAN SHROUD, TXV, REFRIGERATION LINES ACCESS

Evaporator Fan / Fan Shroud / TXV, etc.

- **Caution! Rotating fans can cause severe injury!**
- Turn off main power to unit before removing deck pans and accessing evaporator fan area (as shown in illustrations below).

- Deck pans have finger holes provided to allow easy removal.
- Drain, TXV and refrigeration line route is accessible after removal of fan shroud assembly (as shown at illustration at right). Fan shroud assembly may be removed from case by removing several thumbscrews from fan shroud.
- Return components to case in reverse order they were removed.
- Illustration shown reflects model COU5057R.5854. Your model may vary.

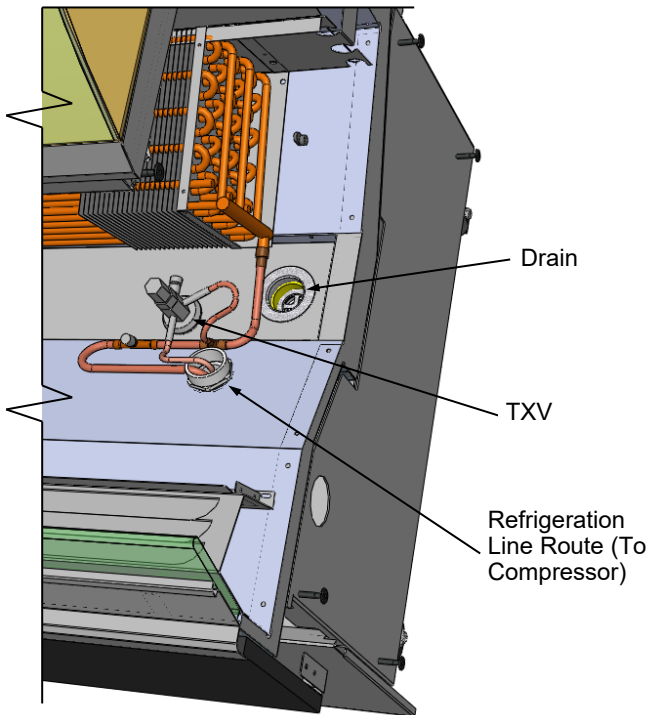

Partially Disassembled View of Components Under Fan Shroud Assembly

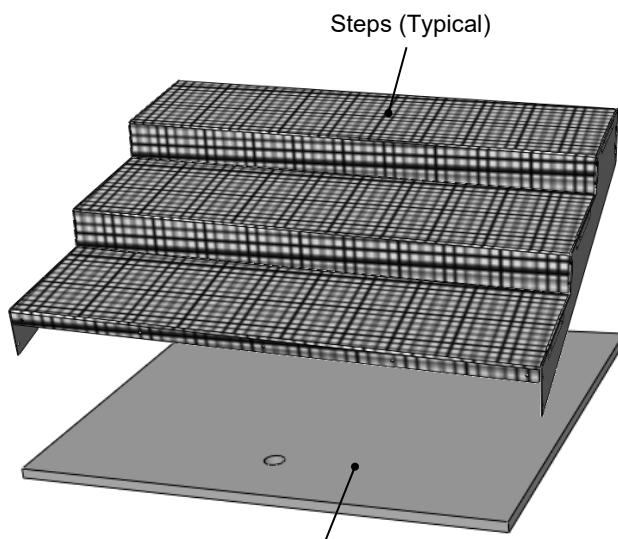

Deck Pan (Typical)

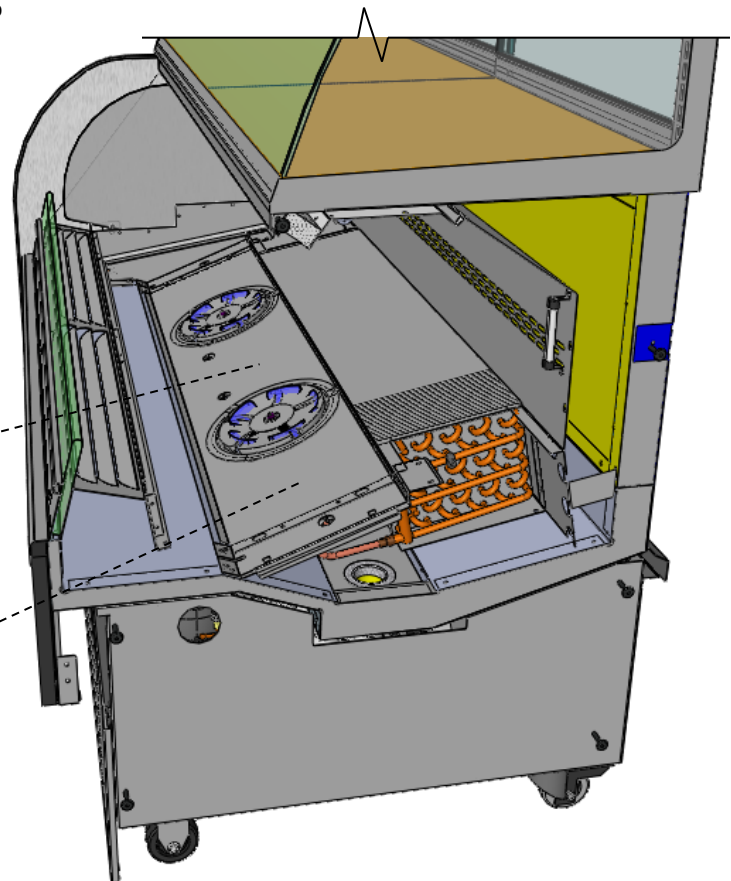

View of Model COU5057R.5854 After Removal of End Panel, Steps and Deck Pans

GENERAL LAYOUT OF CONDENSER PACKAGE ON MODEL COU2757R.5853

Note: Condenser Package Layout Shown Below is Used Primarily on Model COU2757R.5853 Units. See Next Page For Model COU5057R.5854 Condenser Package. Illustration Shown May Not Exactly Reflect Every Feature of Your Unit's Design.

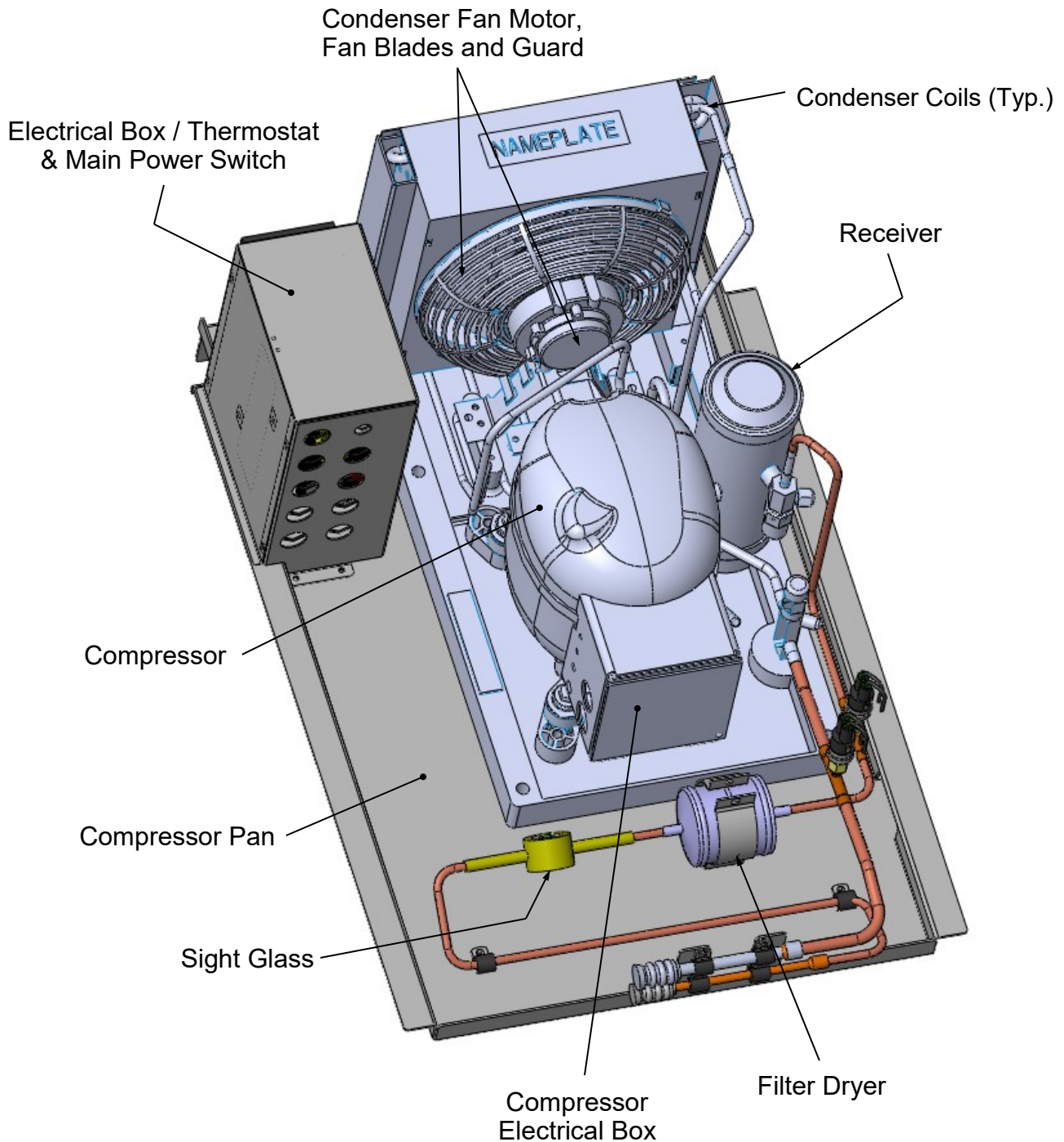

GENERAL LAYOUT OF CONDENSER PACKAGE ON MODEL COU5057R.5854

Note: Condenser Package Layout Shown Below is Used Primarily on Model COU5057R.5854 Units. See Previous Page For Model COU2757R.5853 Condenser Package. Illustration Shown May Not Exactly Reflect Every Feature of Your Unit's Design.

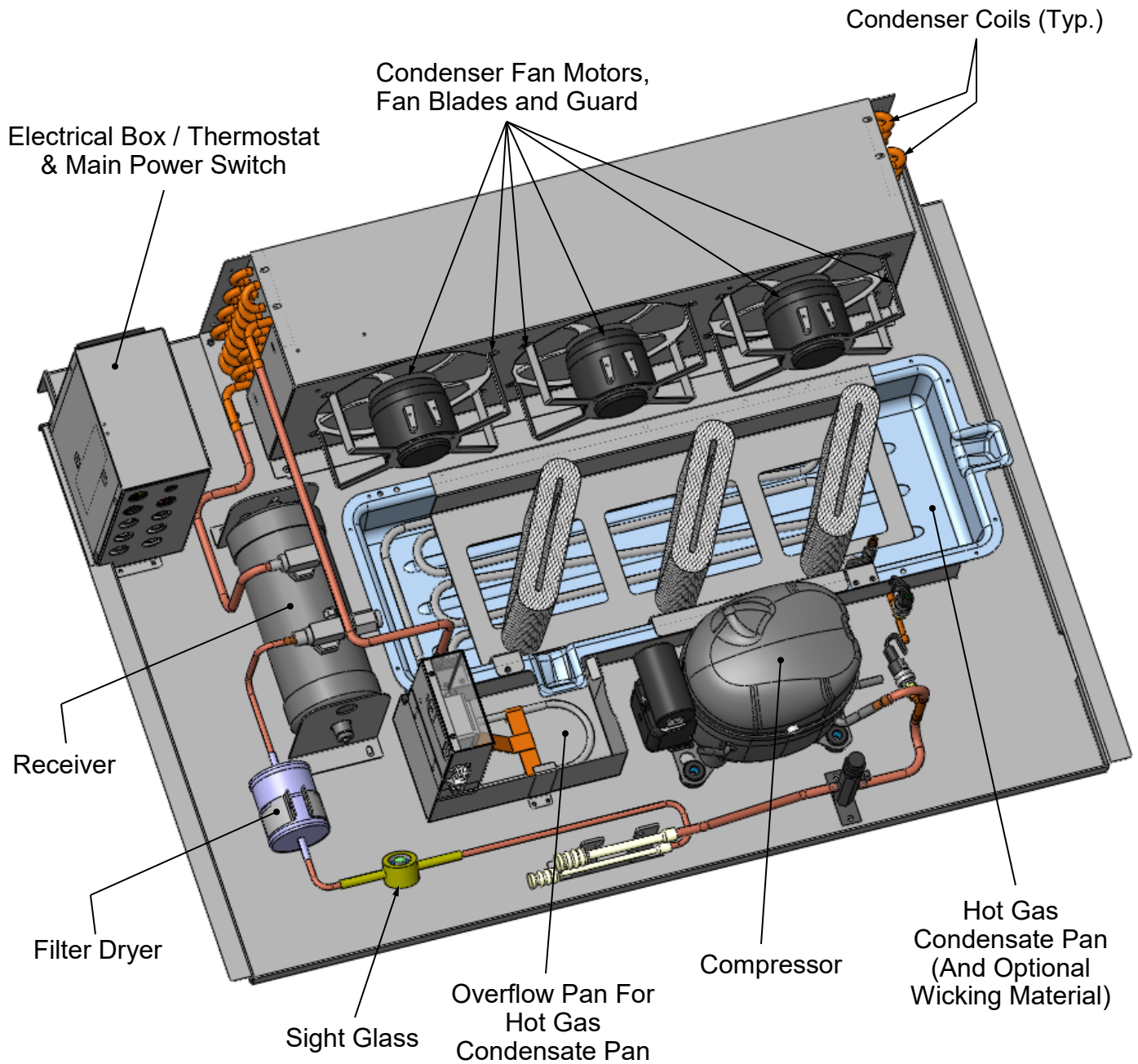

CLEANING SCHEDULE (TO BE PERFORMED BY STORE PERSONNEL)

WARNING! TURN OFF POWER TO CASE BEFORE PERFORMING PREVENTIVE MAINTENANCE!

Freq.	Cleaning Instructions
Daily	<u>Glass / Mirrors</u> : Clean front glass, side glass, glass shelves, and mirrors with a household or commercial glass cleaner.
Daily	<u>Acrylic</u> : Clean with a warm water and mild soap solution and soft cloth. Never use ammonia-based cleaners (or regular glass cleaner) on acrylic.
Daily To Weekly	<u>Magnetic Condenser Coil Filter (Self-Contained Units Only)</u> : <ul style="list-style-type: none"> • This filter helps prevent dust particles from entering condenser coil. • Clean magnetic condenser coil filter by following either of these steps: <ol style="list-style-type: none"> 1. As magnetic condenser coil filter is dishwasher safe, remove from case (no screw removal required) and use a rag or soft-bristled brush to wipe off excess dust particles from filter. Run in normal dishwasher cycle. Remove from dishwasher. Dry with soft cloth or paper towel. Return to case. 2. If not using dishwasher, remove magnetic condenser coil filter from case. Use a rag or soft-bristled brush to wipe off excess dust particles from filter. Submerge in warm, soapy water. Use soft-bristled brush to remove dust, dirt, grease and grime that may collect on filter. Rinse thoroughly.
Weekly	<u>Condensing Coil</u> : Remove base panel and condensing coil cover. Vacuum or brush condenser coil with metal or fiber brush to remove dust and dirt. Be careful to avoid damaging coil fins while cleaning!
Weekly	<u>Rear Sliding Doors and Door Track</u> : Remove rear doors. Clean with household or commercial cleaner. Clean out door track with moist cloth.
Daily	<u>Decks & Inserts (Steps)</u> : Wipe down and clean with mild soap, water & soft cloth.
Weekly	<u>Decks & Inserts (Steps)</u> : Remove and clean with mild soap, water & soft cloth.

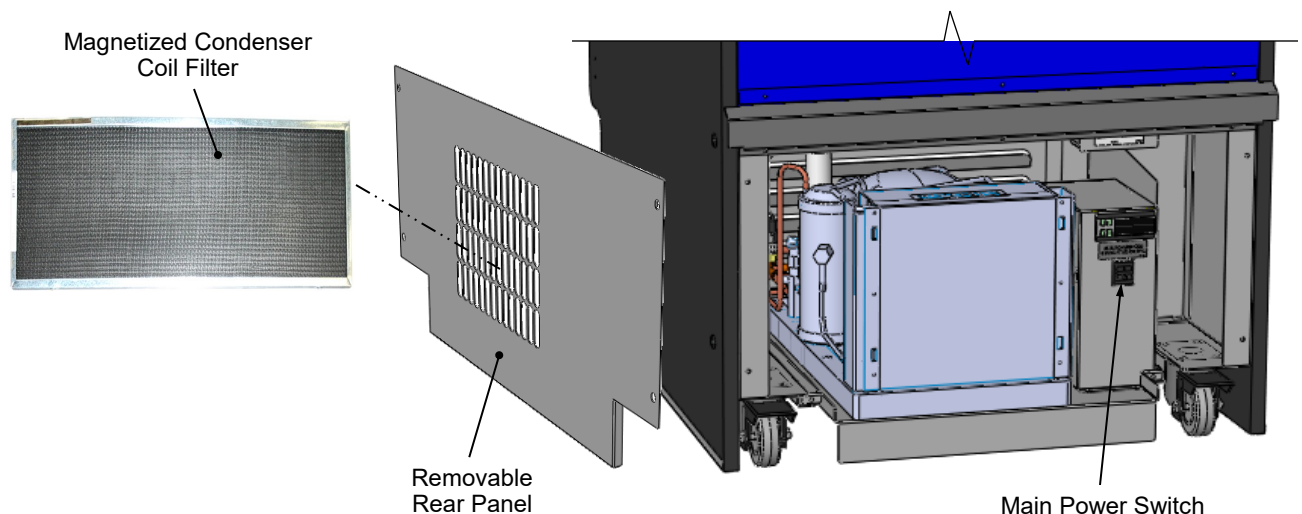

CLEANING SCHEDULE (TO BE PERFORMED BY TRAINED SERVICE PROVIDERS ONLY)

WARNING! TURN OFF POWER TO CASE BEFORE PERFORMING PREVENTIVE MAINTENANCE!

Maintenance	Freq.	Instructions
Case Exterior	Qtly	Condensing Coil: Using air pressure or an industrial strength vacuum, clean the dust and dirt that may collect on the condenser coil. It may be necessary to use a soft-bristled brush to loosen up caked dust and debris that may form on coil.
	Qtly	Under Case Cleaning: Once refrigeration package is clear of unit, vacuum under case to remove all dust and dirt that may collect.
Case Interior	Qtly	Tub, Coil and Drain: Remove evaporator fan panel (as shown in images #1 and 2 below) and clean tub, coil and drain with warm water and mild soap solution. Remove any debris that may clog drain.
	Qtly	Compressor Area: Slide out from case. Wipe off dust & debris w/moist cloth.
	Qtly	Hot Gas Loop (or Electric Coil) Condensate Pan: Disconnect power. Slide out refrigeration assembly. Use a non-corrosive de-scaling solution (that prevents corrosion, lime and rust) to thoroughly clean pan. Use wet /dry vacuum to remove all residue. If necessary, wipe down with damp cloth.
	Qtly	Evaporative Wicking Material (Optional): Lift up and off from support. Replace with new evaporative wicking material.
	Qtly	Fan Blades, Shroud, Drain: Wipe down each blade and shroud with moist cloth. Clean out drain. See images #1 and 2 below.
	Qtly	Honeycomb: See <i>PREVENTIVE MAINTENANCE - HONEYCOMB AIR DIFFUSERS (TRAINED SERVICE PROVIDERS ONLY)</i> section in this manual for specifications.
	Qtly	Upper and Lower Step Inserts: Remove from Case. Clean w/soap and water.

Image #1
Use finger holes to lift up Deck. Remove from case.



Image #2
Clean under Air Return Grille and Fan Shroud Area with moist cloth. Remove drain cleaning access door and clean drain.



PREVENTIVE MAINTENANCE - HONEYCOMB AIR DIFFUSERS (TRAINED SVC. PROVIDERS ONLY)

Honeycomb Air Diffuser Removal

See **PREVENTIVE MAINTENANCE (TO BE PERFORMED BY TRAINED SERVICE PROVIDER)** section in this manual for cleaning frequency.

A. Wedge a non-metallic device of suitable strength (such as a ballpoint pen) between the honeycomb and the end panel.

Caution! Use care not to dislodge the heating wire (that prevents condensation on the lamp assembly).

B. Apply pressure to collapse the honeycomb to allow it to be pulled out of honeycomb retainer.

C. Carefully pry downward and away from the honeycomb retainer. Remove entirely from case.

Clean honeycomb with warm water and soap

solution. Submerge if necessary. Use brush to dislodge stubborn or sticky residue. Dry by using vacuum's blow mode (vs. suction mode).

Honeycomb Air Diffuser Installation

D. Squeeze honeycomb to allow it to fit into the honeycomb retainer.

E. Carefully slide honeycomb into place.

F. Adjust honeycomb so that it fits flat against retainer. It must not be wavy or out of position.

Note: For honeycomb air diffusers in other locations, these same general instructions apply.

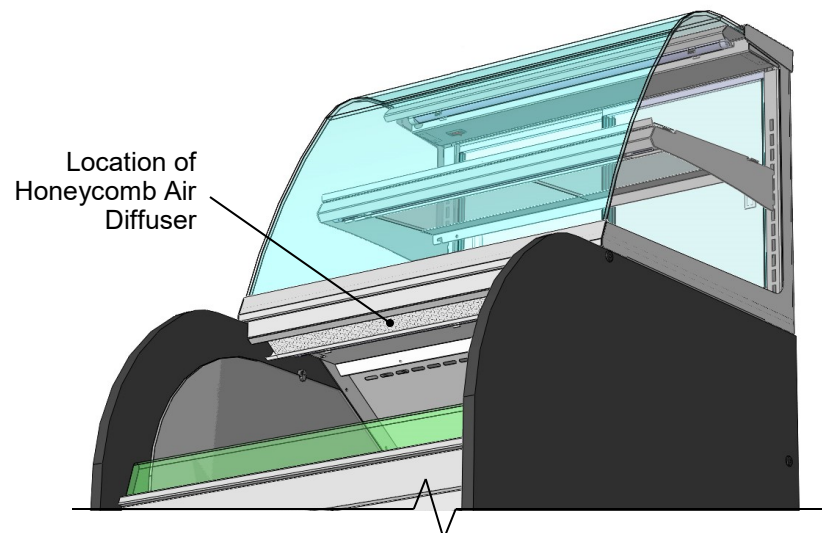
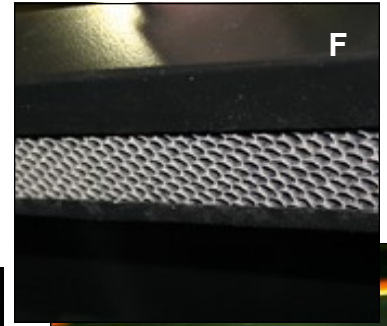
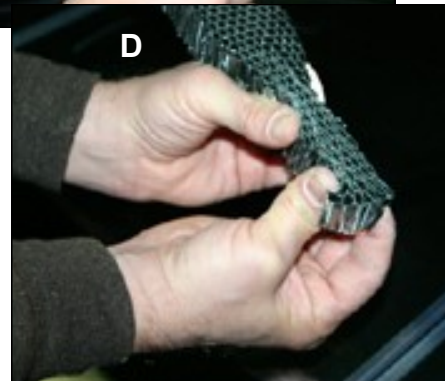

Product is Drying Out	Check the relative humidity in the store.
Water on the Floor	Check that the drain is correctly positioned over condensate pan.
	Check that condensate overflow pan is plugged in.
	Check that drain and drain trap do not have debris in them.
Excessive Fan Noise	Check that the case is aligned, level and plumb.
System is not Operating	Check that the utility power is on.
	Check that the MAIN power switch is on.
	Check the circuit breaker box for tripped circuits.
Alarm is Flashing (or Sounding)	See alarm and fault codes
Digital Control Display is Blank	Check that the MAIN power switch is on.
	Check the circuit breaker box for tripped circuits.
Fans Not Working	Check that the MAIN power switch is on.
Case Lights Not Working	Check that light switch is in the <i>on</i> position.
	Check that ALL of the lights are plugged in.
	Check bulbs for proper installation and connection.
	Check for burned out bulbs.

Note: If problems persist call FCC (Facilities Call Center)

Controller Display Flashing	If display is flashing, refer to Carel® Temperature Controller Section in this manual.
Not Holding Temperature	If a large amount of warm product was added to the case, it will take time for the temperature to adjust. Unit needs pre-chilled product.
	The temperature will change during defrost cycle but will return to normal when compressor turns on.
	Check to see if the condenser coil has been cleaned.
	Check that the case is not in the sun or near a heat or air-conditioning vent. See OVERVIEW / TYPE / COMPLIANCE / WARNINGS / PRECAUTIONS / WIRING section in this manual for specifics.
	Check <i>air</i> grilles for obstruction and remove.
	Ensure that front air grilles are not obstructed by product or other décor.
	<i>Note: Keep product off front air grilles! Product displayed on front air grilles will cause case to run warm and will negate warranty.</i>
Condensing Unit Not Operating	Check that the main power switch is turned on.
	Controller may be in defrost mode. Compressor cycling on and off is a normal condition. See Carel® Temperature Controller Section in this manual.
	Check if the case is on and the control display is blank. If blank, call FCC (Facilities Call Center).

Note: If problems persist call FCC (Facilities Call Center)

CONDITION	TROUBLESHOOTING
<p>Water Is On The Floor</p>	<p>Caution! Disruption of power can cause water to overflow pan and seep onto flooring causing damage! Check that power to case is constant. Until power is restored, follow these procedures:</p> <ul style="list-style-type: none"> • Use wet-dry vacuum (or mop & bucket) to remove standing water. • Use 'catch pans' for water to drainage. Swap out regularly until evaporation of case is complete (or until power is restored). • When power to case is restored, evaporator pan should function properly and water will no longer overflow onto flooring.
	<p>Check that the drain trap is free of debris.</p>
	<p>Check that the drain hose is correctly positioned over condensate pan (or floor drain, for remote units).</p>
	<p>Check store conditions. To prevent condensation in Type I environments, maximum conditions are to be 55% humidity / 75° Fahrenheit. For Type II, maximum conditions are to be 55% humidity / 80° Fahrenheit. See serial label (at case rear near main power switch) for "Type" of your case.</p>
	<p>Check that evaporator pan is properly plugged in or connected.</p>
	<p>Caution! Wicking material (hot gas loop condensate system only) may be dirty or worn and need replacement.</p> <ul style="list-style-type: none"> • Slide refrigeration system out from under unit. • After refrigeration system has been carefully slid out from under unit, replace wicking material with new. If wicking material is not available, contact Structural Concepts®. See toll-free number at last page of this operating manual.

CONDITION	TROUBLESHOOTING
Fan Emits Excessive Noise	Check that the case is aligned, level and plumb.
	Check evaporator fan for cleanliness.
	Unplug/power off fan motors. Check motor shaft for bearing wear.
	Check that fan motors are securely mounted in brackets.
	Verify that fan blades are securely mounted to fan motor.
	Check that nothing is preventing blade rotation.
	Check that the fan shroud is properly secured.
Fans Are Not Working	Check that the MAIN power switch is on.
	Check that fans are plugged in at the fan shroud.
	Check for foreign material obstructing fan performance.
	Check that fan blades freely rotate within fan shrouds
	Check that power is going to fans
	Check that fan wiring is connected on terminal blocks.
Digital Control Display Is Blank	Check that the MAIN power switch is on.
	Check the circuit breaker box for tripped circuits.
System Not Operating	Check that the utility power is on.
	Check that the MAIN power switch is on.
	Check the circuit breaker box for tripped circuits.

CONDITION	TROUBLESHOOTING
Case Lights Are Not Working	Check that light switch is on. See START-UP AND OPERATION in this manual for location.
	Check that ALL of the light cords and plugs are properly connected. See MAINTENANCE FUNDAMENTALS section in this manual.
	Check voltage at ballast (or driver). If voltage is entering but not exiting, ballast (or driver) may be faulty.
Control Display Is Flashing	See your case's serial label for your model's specified settings. See SERIAL LABEL LOCATION & INFORMATION LISTED / TECH INFO & SERVICE for label location, etc.
Case Is Not Holding Temperature	If a large amount of warm product was added to the case, it will take time for the temperature to adjust. Unit needs product to be pre-chilled.
	Temperature changes during defrost mode but will return to normal. Fourth LED will indicate defrost cycle in progress.
	Check that case is not in sun or near a heat or air-conditioning vent. See OVERVIEW / TYPE / COMPLIANCE / WARNINGS / PRECAUTIONS / WIRING section in manual for adverse conditions/spacing issue parameters.
	If case is located near front doors, temperature fluctuation can hinder unit's ability to maintain temperature. See OVERVIEW / TYPE / COMPLIANCE / WARNINGS / PRECAUTIONS / WIRING section in manual for adverse conditions/spacing issue parameters.
	Check that magnetized condenser coil air filter (attached to rear grille) has been cleaned. See GENERAL CLEANING (TO BE PERFORMED BY STORE PERSONNEL) section in operating manual for instructions.
	Check that condenser coil has been cleaned.
	Check air return grilles for obstructions.
	Check sight glass for flashing and/or low charge.
	Check Set Point Temperature; it may be adjusted too high.
Condensing Unit Is Not Operating	Check that the power is turned on.
	Determine if temperature controller settings are properly set. See your case's serial label for your model's specified settings. See SERIAL LABEL LOCATION & INFORMATION LISTED / TECH INFO & SERVICE section in manual for label location, etc.

TROUBLESHOOTING - CONDENSING SYSTEM (BY TRAINED SERVICE PROVIDERS ONLY)

CONDITION	TROUBLESHOOTING
Head Pressure Too High	Check that the condensing coil is not dirty or covered.
	Check that condensing fans are working.
	Check that refrigerant is not overcharged.
	Perform sub-cooling check and verify that no contaminants are in system.
	Check that liquid line filter dryer is not plugged.
	Check that close-offs are intact (around condensing coil) and that air is not recirculate.
	<ul style="list-style-type: none"> • Check that store ambient temperature isn't above maximum allowed. • See OVERVIEW / TYPE / COMPLIANCE / WARNINGS / PRECAUTIONS / WIRING / PLUGS section in this manual.
Head Pressure Too Low	Check if sight glass is flashing or showing low charge.
	Check that suction pressure isn't too low.
	Check that compressor reed valves aren't bad. Look for high suction/low head pressure. Perform pump-down.

TROUBLESHOOTING - EVAPORATOR SYSTEM (BY TRAINED SERVICE PROVIDERS ONLY)

CONDITION	TROUBLESHOOTING
Low Suction Pressure	Check if sight glass is flashing or showing low charge.
	Check that expansion valve (TXV) isn't restricted. Check element charge.
	Check that liquid line or filter isn't restricted. Check that refrigeration lines and/or hoses are not kinked on either high or low sides.
	Check that evaporator fan motors are working.
	Check that superheat is between 6 °F to 8 °F.
	Check that there is no air recirculation around evaporator coil.
	Check that evaporator coil is not iced up.
High Suction Pressure	Check for refrigerant overcharge.
	Check that compressor reed valves aren't bad. Look for high suction/low head pressure. Perform pump down.
	Check that the "cooling load" isn't high. Product must be pre-chilled before placing in refrigerated section of case.
	Check that case is at least <u>15-feet</u> from exterior doors, overhead HVAC vents or any air curtain disruption.
	Check that unit is not exposed to direct sunlight via windows or any other heat source (ovens, fryers, etc.).
	Check that superheat adjustment isn't low.
	Check TXV bulb installation a. Poor thermal contact. b. Warm location.

Serial Label Location & Information Listed / Technical Information & Service

- Serial labels are affixed at a wide range of places (on the header, near thermostat, at case rear, behind panels/toe-kicks, on electrical boxes, etc.).
- Serial labels contain electrical, temperature and refrigeration information, as well as regulatory standards to which the case conforms.
- Sample serial labels shown below.
- For additional technical information and service, see the *TECHNICAL SERVICE* page in this manual for instructions on contacting Structural Concepts' Technical Service Department.

→
Sample Serial Label For Refrigerated Cases

Structural Concepts®
888 E. Porter Rd - Muskegon, MI 49441

Reveal MODEL NRS3648RXV-SAMPLE
SERIAL NO. 12345X30DZ098765

Blend

Harmony Addenda *SAMPLE ONLY*

Impulse Grocerant

Oasis Fusion *SAMPLE ONLY*

Intertek Intertek

3048256
Conforms to UL Std. 471
Conforms to NSF/ANSI Stds. 2 & 7
CERTIFIED TO CAN/CSA
STD C22.2 NO 120

ELECTRICAL RATING
REFRIGERANT
DESIGN PRESSURE
MINIMUM CIRCUIT AMPACITY
MAXIMUM OVERCURRENT

120/1/60 16 A
R513A AMOUNT 50 OZ
HIGH 186 LOW 88
20A
20A

Super Heat Temp
Defrost

6-8 °F
6 defrosts per day, 45 °F

FOR PARTS AND SERVICE CALL
1-800-433-9490

TYPE II DISPLAY REFRIGERATOR: THIS EQUIPMENT IS INTENDED FOR USE IN AN AREA WHERE THE ENVIRONMENTAL CONDITIONS ARE CONTROLLED AND MAINTAINED SUCH THAT THE AMBIENT TEMPERATURE DOES NOT EXCEED 80 °F (27 °C).

 WARNING: This product can expose you to chemicals, including Urethane (Ethyl Carbamate), which are known to the state of California to cause cancer and birth defects or other reproductive harm. For more information go to P65Warnings.ca.gov.

Sample QR Code

→
Sample Serial Label For Ambient or Heated Cases

Structural Concepts®
888 E. Porter Rd - Muskegon, MI 49441

Blend MODEL NRS3648RXV-SAMPLE
SERIAL NO. 12345X30DZ098765

Harmony Reveal *SAMPLE ONLY*

Grocerant Addenda

Fusion Oasis *SAMPLE ONLY*

Impulse *SAMPLE ONLY*

Intertek

3048256
Conforms to UL Std. 65
CERTIFIED TO CAN/CSA
STD C22.2 NO 120

120 VOLTS 60HZ
FOR PARTS OR SERVICE CALL
STRUCTURAL CONCEPTS
AT 1-800-433-9489

SINGLE PHASE 1.84 AMPS

 WARNING: This product can expose you to chemicals, including Urethane (Ethyl Carbamate), which are known to the state of California to cause cancer and birth defects or other reproductive harm. For more information go to P65Warnings.ca.gov.

Sample QR Code

CAREL

ir33 platform

Integrated Electronic
Microprocessor Controller



Programming The Instrument

To Modify Defrost, Differential and Other Parameters

Prg **Set** 1. Press & hold “Prg” & “SET” keys together for at least five (5) seconds; display will flash “0,” representing password prompt.

▲ **aux** 2. Press ▲ until password “22” is reached.

Set 3. Press “SET” key to confirm password.

▲ **def** **▼** 4. Press ▲ or ▼ to reach a category to be modified.

Set 5. Press “SET” to modify selected parameter.

▲ **def** **▼** 6. Increase or decrease the value using the ▲ or ▼ button respectively.

Set 7. Press the “SET” key to temporarily save the new value and return to the parameter display.

Prg **mute** 8. Press & hold the “Prg” key for 5 full seconds to save changes. This will also mute the audible alarm (buzzer) and deactivate the alarm relay.

Warning! Save Your Parameter Settings!

1. To store the new parameter values, PRESS and HOLD the “Prg” key for at least 5 seconds.
2. All modifications made to parameters will be lost if you do NOT press a button within 60 seconds. Should this “timeout” occur, normal operational settings (prior to modifications being made) will resume.
3. If the instrument is switched off before pressing the “Prg” key, all modifications to parameters will be lost.

To Activate Manual Defrost

def **▼** Press and hold “def” key for at least 5 seconds.

To Activate / Deactivate Auxiliary Output

▲ **aux** Press and hold the “aux” key for 1 second.

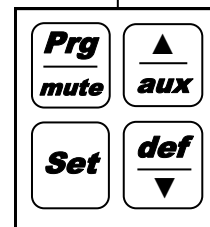

How To Change Reading From Fahrenheit (°F) To Celsius (°C)

Prg **Set** 1. Press and hold “Prg” and “SET” keys together for at least 5 seconds; display will show “0” (password prompt).

▲ **aux** 2. Press ▲ until password “22” is reached.

Set 3. Confirm by pressing “SET” key.

▲ **def** **▼** 4. Press ▲ or ▼ until reaching the parameter “/ 5.”

Set 5. Press “SET” to modify this selected parameter.

▲ **def** **▼** 6. Press ▲ or ▼ to change value to desired setting: “0” for Celsius (°C) or “1” for Fahrenheit (°F).

Set 7. Press “SET” key to temporarily save the new value and return to the display of the parameter.

Prg **mute** 8. Press & hold “Prg” key for 5 full seconds to save changes. **Note! All values will automatically convert to new scale. No conversion is required.**

To Reset Any Alarms With Manual Reset

Prg **▲** **aux** **mute** Press and hold the “Prg” and “aux” key for at least 1 second.

This data derived from Carel® Controller Material:
ir33 +030220441 - rel. 2.0 - 01.05.2006.
User Manuals\Carel ir33 Platform Programmable Controller For
Refrig Units - Rev C Date: 06/22/2022

CAREL

ir33 platform

Integrated Electronic
Microprocessor Controller



User Interface - Display

ICON	FUNCTION	DESCRIPTION	Normal operation		BLINK	Start up
			ON	OFF		
	COMPRESSOR	ON when the compressor starts. Flashes when the activation of the compressor is delayed by safety times.	Compressor on	Compressor off	awaiting activation	
	FAN	ON when the fan starts. Flashes when the activation of the fan is prevented due to external disabling or procedures in progress.	Fan on	Fan off	awaiting activation	
	DEFROST	ON when the defrost is activated. Flashes when the activation of the defrost is prevented due to external disabling or procedures in progress.	Defrost in progress	Defrost not in progress	awaiting activation	
	AUX	Flashes if the anti-sweat heater function is active, ON when the auxiliary output (1 and/or 2) selected as AUX (or LIGHT in firmware version 3.6) is activated.	AUX auxiliary output active (version 3.6 light auxiliary output active)	AUX auxiliary output not active	Anti-sweat heater function active	
	ALARM	ON following pre-activation of the delayed external digital input alarm. Flashes in the event of alarms during normal operation (e.g. high/low temperature) or in the event of alarms from an immediate or delayed external digital input.	Delayed external alarm (before the time 'A7' elapses)	No alarm present	Alarms in norm. operation (e.g. High/low temperature) or immediate or delayed alarm from external digital input	
	CLOCK	ON if at least one timed defrost has been set. At start-up, comes ON for a few seconds to indicate that the Real Time Clock is fitted.	If at least 1 timed defrost event has been set	No timed defrost event set	Alarm clock	ON if real-time clock present
	LIGHT	Flashes if the anti-sweat heater function is active, ON when the auxiliary output (1 and/or 2) selected as LIGHT is activated (in firmware version 3.6 it does not flash in anti-sweat heater mode and comes on when the dead band output is active).	Light auxiliary output on (version 3.6 dead band auxiliary output active)	Light auxiliary output off	Anti-sweat heater function active (version 3.6 does not flash in anti-sweat heater mode)	
	SERVICE	Flashes in the event of malfunctions, for example E2PROM errors or probe faults.		No malfunction	Malfunction (e.g. E2PROM error or probe fault). Contact service	
	CONTINUOUS CYCLE	ON when the CONTINUOUS CYCLE function is activated. Flashes if the activation of the function is prevented due to external disabling or procedures in progress (E.g.: minimum compressor OFF time).	CONTINUOUS CYCLE operation activated	CONTINUOUS CYCLE function not activated	CONTINUOUS CYCLE operation requested	

Summary Table of Alarm and Signals: Display, Buzzer and Relay

Code	Icon on the display	Alarm relay	Buzzer	Reset	Description
rE		on	on	automatic	virtual control probe fault
E0		off	off	automatic	room probe S1 fault
E1		off	off	automatic	defrost probe S2 fault
E2		off	off	automatic	probe S3 fault
E3		off	off	automatic	probe S4 fault
E4		off	off	automatic	probe S5 fault
	No	off	off	automatic	probe not enabled
LO		on	on	automatic	low temperature alarm
HI		on	on	automatic	high temperature alarm
AFr		on	on	manual	antifreeze alarm
IA		on	on	automatic	immediate alarm from external contact
dA		on	on	automatic	delayed alarm from external contact
dEF		off	off	automatic	defrost running
Ed1	No	off	off	automatic/manual	defrost on evaporator 1 ended by timeout
Ed2	No	off	off	automatic/manual	defrost on evaporator 2 ended by timeout
Pd		on	on	automatic/manual	maximum pump down time alarm
LP		on	on	automatic/manual	low pressure alarm
AtS		on	on	automatic/manual	autostart in pump down
cht	No	off	off	automatic/manual	high condenser temperature pre-alarm
CHT		on	on	manual	high condenser temperature alarm
dor		on	on	automatic	door open too long alarm
EE		off	off	automatic	E2prom error, unit parameters
EF		off	off	automatic	E2prom error, operating parameters
ccb	Signal				start continuous cycle request
cce	Signal				end continuous cycle request
dFb	Signal				start defrost call
dFE	Signal				end defrost call
On	Signal				switch ON
off	Signal				switch OFF
rES	Signal				reset alarms w/manual reset / reset HACCP alarms / reset temp. monitoring

This data derived from Carel® Controller Material:
ir33 +030220441 - rel. 2.0 - 01.05.2006.
User Manuals\Carel ir33 Platform Programmable Controller For
Refrig Units - Rev C Date: 06/22/2022

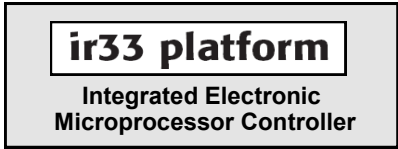

Summary Table of Operating Parameters

CODE	PARAMETER	UOM*	TYPE	MINIMUM	MAXIMUM	DEFAULT
/5	Select Celsius (°C) or Fahrenheit (°F)	flag	C	0	1	For Case Specific Defaults See Serial Label Located Near Electrical Access On Your Case. For Additional Technical Information Call Structural Concepts Technical Service Dept. at 1(800) 433.9490 Ext. 1
/c1	Calibration of probe 1	°C/°F	C	-20	20	
/c2	Calibration of probe 2	°C/°F	C	-20	20	
St	Temperature set point	°C/°F	F	r2	r1	
rd	Control delta	°C/°F	F	20	0.1	
dl	Interval between defrosts	hours	F	0	250	
d4	Defrost activated when instrument is switched on**	-	-	0	1	
dt1	End defrost temperature, evaporator	°C/°F	F	-50	200	
dP1	Maximum defrost duration, evaporator	min	F	1	250	
d6	Display on hold during defrost	-	C	0	2	
dd	Dripping time after defrost	min	F	0	15	
d/1	Display of defrost probe 1	°C/°F	F	-	-	

* Unit Of Measure

** Case will go into defrost ONLY when case is turned off and then back on when probe is reading below 45 °F.

This data derived from Carel® Controller Material:
 ir33 +030220441 - rel. 2.0 - 01.05.2006.
 User Manuals\Carel ir33 Platform Programmable Controller For
 Refriger Units - Rev C Date: 06/22/2022

STRUCTURAL CONCEPTS TECHNICAL SERVICE CONTACT INFORMATION & LIMITED WARRANTY

TECH SERVICE/WARRANTY CONTACT INFO:

1 (800) 433-9490 / EXTENSION 1

DAYS/HOURS AVAILABLE:

MONDAY - FRIDAY (CLOSED HOLIDAYS)
8:00 a.m. TO 5:00 p.m. EST

YOU MUST HAVE THE FOLLOWING INFO AVAILABLE BEFORE CONTACTING STRUCTURAL CONCEPTS:

SERIAL NO. / MODEL NO. / STORE NO. / STORE ADDRESS / DETAILS (PHOTOS, LEAK LOCATIONS, DAMAGE, STORE'S AMBIENT CONDITIONS, ETC.)

Starbucks Limited Warranty

Overview: All sales by Structural Concepts Corporation (hereafter referred to as "Structural Concepts") are subject to the following limited warranty. "Goods" refers to the product or products being sold by Structural Concepts.

Warranty Scope: Warranty is for equipment sold ONLY to Starbucks Corporation and its licensees in the United States, Canada, Mexico and Puerto Rico. Equipment sold elsewhere may carry modified warranties.

Warranty; Remedies; Limitations: Limit of liability of Structural Concepts toward the exchange cost of the original compressor motor (and/or any other components) is one year parts and labor. If any Goods are found to be of faulty material or workmanship within one year of the original F.O.B. (free on board) unit shipment, Structural Concepts will, at its option (after inspection by an authorized representative), replace or pay the reasonable cost of replacement of the faulty Goods. If warranty claim is not made within this one year time period, Structural Concepts is not bound to warrant Goods. A motor-compressor (and/or any other components) replaced during the warranty shall not exceed manufacturer's current established wholesaler's exchange price. If replacement motor-compressor (and/or other components) is available via storage facility, parts truck, etc., Structural Concepts mandates that readily accessible replacement components be used toward repair of Goods; in such instances, Structural Concepts will replace such equipment (at its own expense) after confirmation of its use/placement on defective unit. Structural Concepts shall not be charged an additional fee, up-charge or expense for such replacement Goods. If Structural Concepts is unable to repair or replace the defective Goods, Structural Concepts shall issue a credit to the Purchaser for full or partial purchase price, as Structural Concepts shall determine. The replacement or payment in the manner described above shall be the sole and exclusive remedy to Purchaser for a breach of this warranty. If any Goods are defective or fail to conform to this warranty, Structural Concepts will furnish instructions for their disposition. No Goods shall be returned to Structural Concepts without its prior consent.

Structural Concepts' liability for any defect in the Goods shall not exceed the purchase price of the Goods. Structural Concepts SHALL HAVE NO LIABILITY TO PURCHASE FOR CONSEQUENTIAL DAMAGES OF ANY KIND WHATSOEVER, INCLUDING, BUT NOT LIMITED TO, PERSONAL INJURY, PROPERTY DAMAGE, LOST PROFITS, OR OTHER ECONOMIC INJURY DUE TO ANY DEFECT IN THE GOODS OR ANY BREACH OF Structural Concepts, Structural Concepts SHALL NOT BE LIABLE TO THE PURCHASER IN TORT FOR ANY NEGLIGENT DESIGN OR MANUFACTURE OF THE GOODS, OR FOR THE OMISSION OF ANY WARNING THEREFROM.

Structural Concepts shall have no obligation or liability under this warranty for claims arising from any other party's (including Purchaser's) negligence or misuse of the Goods or environmental conditions. This warranty does not apply to any claim or damage arising from or caused by improper storage, handling, installation, maintenance, or from fire, flood, accidents, structural defects, building settlement or movement, acts of God, or other causes beyond Structural Concepts' control.

Except as expressly stated herein, Structural Concepts makes no warranty, express, implied, statutory or otherwise as to any parts or goods not manufactured by Structural Concepts. Structural Concepts shall warrant such parts or Goods only (I) against such defects, (II) for such periods of time, and (III) with such remedies, as are expressly warranted by the manufacturer of such parts of Goods. Notwithstanding the foregoing, any warranty with respect to such parts of Goods and any remedies available as a result of a breach thereof shall be subject to all of the procedures, limitations, and exclusions set forth herein.

THE WARRANTIES HEREIN ARE IN LIEU OF ALL WARRANTIES, EXPRESS, IMPLIED, STATUTORY, OR OTHERWISE. IN PARTICULAR, Structural Concepts MAKES NO WARRANTY OF MERCHANTABILITY OR FITNESS FOR A PARTICULAR PURPOSE.

No representative, agent or dealer of Structural Concepts has authority to modify, expand, or extend this Warranty, to waive any of the limitations or exclusions, or to make any different or additional warranties with respect to Goods.

Period of Limitations: No claim, suit or other proceeding may be brought by Purchaser for any breach of the foregoing warranty or this Agreement by Structural Concepts or in any way arising out of this Agreement or relating to the Goods after one year from the date of the breach. In the interpretation of this limitation on action for a breach by Structural Concepts, it is expressly agreed that there are no warranties of future performance of the goods that would extend that period of limitation herein contained for bringing an action.

Indemnifications: Purchaser agrees to indemnify, hold harmless, and defend Structural Concepts if so requested, from any and all liabilities, as defined herein, suffered, or incurred by Structural Concepts as a result of, or in connection with, any act, omission, or use of the Goods by Purchaser, its employees or customers, or any breach of this Agreement by Purchaser. Liabilities shall include all costs, claims, damages, judgments, and expenses (including reasonable attorney fees and costs).

Remedies of Structural Concepts: Structural Concepts' rights and remedies shall be cumulative and may be exercised from time to time. In a proceeding or action relating to the breach of this Agreement by Purchaser, Purchaser shall reimburse Structural Concepts for reasonable costs and attorney's fees incurred by Structural Concepts. No waiver by Structural Concepts of any breach of Purchaser shall be effective unless in writing nor operate as a waiver of any other breach of the same term thereafter. Structural Concepts shall not lose any right because it has not exercised it in the past.

Applicable Law. This Agreement is made in Michigan and shall be governed by and interpreted according to Michigan law. Any lawsuit arising out of this Agreement or the Goods may be handled by a federal or state court whose district includes Muskegon County, Michigan, and Purchaser consents that such court shall have personal jurisdiction over Purchaser.

Miscellaneous: If any provision of this Agreement is found to be invalid or unenforceable under any law, the provision shall be ineffective to that extent and for the duration of the illegality, but the remaining provisions shall be unaffected. Purchaser shall not assign any of its rights nor delegate any of these obligations under this Agreement without prior written consent of Structural Concepts. This Agreement shall be binding upon and inure to the benefit of Structural Concepts and Purchaser and each of their legal representatives, successors and assignees.

Structural Concepts warrants its products to be free of defects in materials and workmanship under normal use and service for a period of one (1) year.

This warranty is extended only to the original purchaser for use of the Goods. It does not cover normal wear parts such as plastic tongs, tong holders, tong cables, bag holders, or acrylic dividers.

General Conditions: All service labor and/or parts charges are subject to approval by Structural Concepts. Contact Customer Service Dept. in writing, by phone, fax or email.

All claims must contain the following information: (1) model & serial code number of equipment; (2) the date and place of installation; (3) the name and address of the agency which performed the installation; (4) the date of the equipment failure; and (5) a complete description of the equipment failure and all circumstances relating to that failure.

Once the claim has been determined to be a true warranty claim by Structural Concepts' Customer Service Department, the following procedure will be taken: (1) replacement parts will be sent at no charge from Structural Concepts on a freight prepaid basis; (2) reimbursement for service labor will be paid if the following conditions have been met - (a) prior approval of service agency was awarded from the Customer Service Department; and (b) an itemized statement of all labor charges incurred is received by the Customer Service Department. The cost of the service labor reimbursement will be based on straight time rates and reasonable time for the repair of the defect.

If problems occur with any compressor, notify Structural Concepts' Customer Service Department immediately. Any attempt to repair or alter the unit without prior consent from the Customer Service Department may render any warranty claim null and void. This warranty and protection plan does not apply to any condensing unit or any part thereof which has been subject to accident, negligence, misuse, or abuse, or which has not been operated in accordance with the manufacturer's recommendations or if the serial number of the unit has been altered, defaced, or removed.

One Year Limit of Liability: After Structural Concepts' one-year parts and labor warranty on the original F.O.B. (free on board) unit has expired, Structural Concepts is not liable for either the equipment or labor costs of repairing or replacing the motor compressor, nor any other components that were included in the original F.O.B. (free on board) unit.