

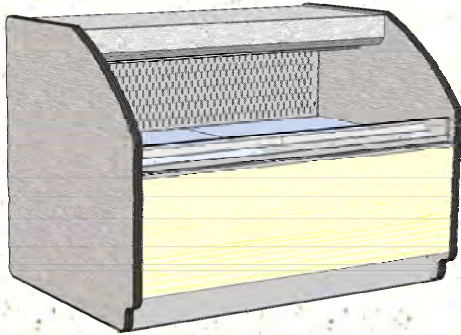

# INSTALLATION AND OPERATING MANUAL

PN 20-24002

## SELF-SERVICE REFRIGERATED MERCHANDISER



Model CO43R With Curved End Panels

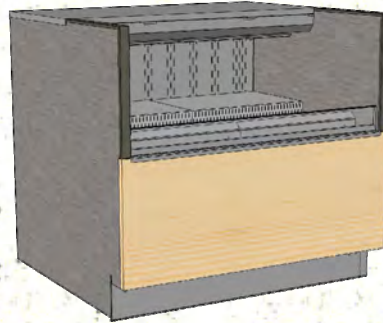

Model CO33R With Counter End Panels And Continuous Top & Front

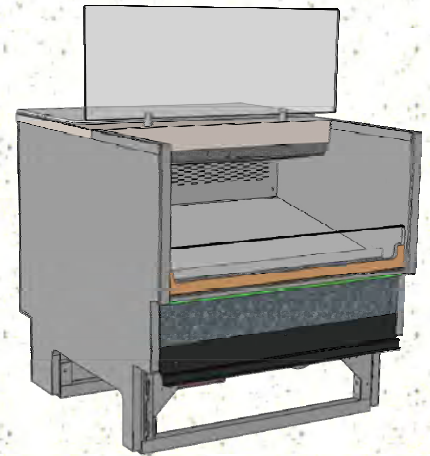

Model CO3436RG.5716 Without Front Panel / With Angled Riser and Vertical Sneeze Guard

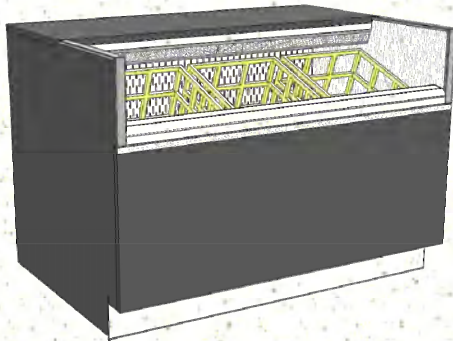

Model CO43RM Under Counter Unit

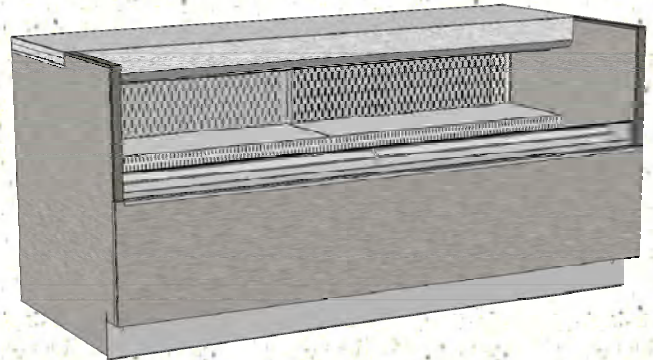

Model CO63R With Counter End Panels And Continuous Top & Front

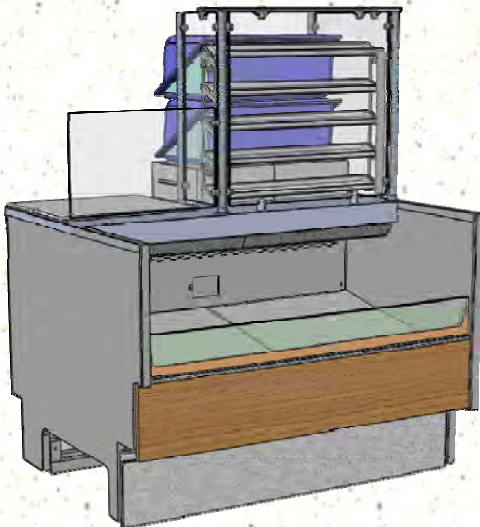

Model CO3436R.5716 and CO4836RG.5716 (Glycol Unit) Includes SCC's Model BDXXXX Removable Bread Display On Counter (Next To Sneeze Guard)

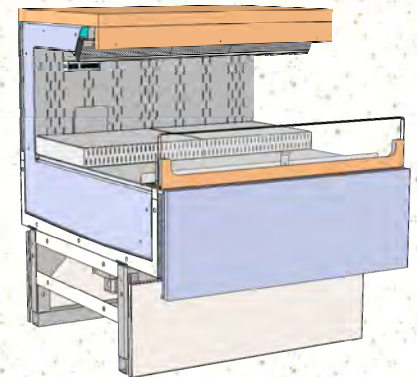

Model CO3034RG.5718 & CO3034RG.5718A With Product Steps

**Models Represented In This Operating Manual**  
CO33R / CO43R / CO53R / CO63R / CO43RM / CO4324R / CO63RM / CO3034RG.5718 / CO3034RG.5718A / CO3436RG.5716 / CO4836R.5716 / CO4836RG.5716



888 E. Porter Road · Muskegon, MI 49441 Phone: 231.798.8888 Fax: 231.798.4960 www.structuralconcepts.com

## TABLE OF CONTENTS

<b>OVERVIEW / TYPE / COMPLIANCE / WARNINGS / PRECAUTIONS / WIRING / PLUGS .....</b>	<b>3-4</b>
<b>SHIPPING BRACKET REMOVAL / TOE-KICK REMOVAL / REMOVING CASE FROM SKID .....</b>	<b>5</b>
<b>CAULKING / SEALING / BOLTING ADJOINED UNITS .....</b>	<b>6</b>
<b>SHIMMING FRAME SUPPORT RAILS / ADJUSTING LEVELERS .....</b>	<b>7</b>
<b>START-UP AND OPERATION: T'STAT / MAIN POWER SWITCH / LIGHTS SWITCH / FILTER .....</b>	<b>8</b>
<b>PRODUCT PLACEMENT / HONEYCOMB AIRFLOW CONSIDERATION / LOAD LINES .....</b>	<b>9</b>
<b>MAINTENANCE - TOE-KICKS / LIGHT FIXTURES / NIGHT CURTAIN, HONEYCOMB, THERMOMETER .....</b>	<b>10</b>
<b>MAINTENANCE - REMOVABLE FRONT PANELS (NON-MAGNETIC) .....</b>	<b>11</b>
<b>MAINTENANCE - REMOVABLE FRONT PANELS (MAGNETIC) .....</b>	<b>12</b>
<b>MAINTENANCE - LED LIGHT FIXTURE / LOCATION / REPAIR / REPLACEMENT .....</b>	<b>13</b>
<b>MAINTENANCE - OPTIONAL NIGHT AIR CURTAIN OPERATING INSTRUCTIONS .....</b>	<b>14</b>
<b>MAINTENANCE - ELECTRICAL ACCESS AND COMPONENTS .....</b>	<b>15</b>
<b>MAINTENANCE - REAR COMPONENT LAYOUT (MODEL CO3436RG.5716 ONLY) .....</b>	<b>16</b>
<b>MAINTENANCE - OPTIONAL SECURITY COVER (MODEL CO43RM / CO63RM, ETC.) .....</b>	<b>17</b>
<b>MAINTENANCE - MODEL CO4836R.5716 &amp; CO4836RG.5716 / REMOVABLE BREAD DISPLAY...</b>	<b>18</b>
<b>REFRIGERATION - EVAPORATOR AREA: MODELS CO33R / CO43R / CO4324R / CO53R / CO63R .....</b>	<b>19</b>
<b>REFRIGERATION - EVAPORATOR AREA: MODELS CO43RM / CO63RM (AND SIMILAR UNITS)</b>	<b>20</b>
<b>REFRIGERATION - EVAPORATOR AREA: MODELS CO3434RG.5716, CO3436RG.5716, CO3034RG.5718 &amp; CO3034RG.5718A .....</b>	<b>21</b>
<b>REFRIGERATION - CONDENSATE PACKAGE ACCESS (SCREW REMOVAL REQUIRED) .....</b>	<b>22</b>
<b>REFRIGERATION - CONDENSATE PACKAGE ACCESS (NO SCREW REMOVAL REQUIRED) ....</b>	<b>23</b>
<b>REFRIGERATION - CONDENSATE PACKAGE ILLUSTRATED PARTS BREAKDOWN (CO**R) ...</b>	<b>24</b>
<b>REFRIGERATION - CONDENSATE PACKAGE (CO3436RG.5716 / CO3034RG.5718 / CO3034RG.5718A) .....</b>	<b>25</b>
<b>GENERAL CLEANING (TO BE PERFORMED BY STORE PERSONNEL) - EXTERNAL .....</b>	<b>26</b>
<b>GENERAL CLEANING (TO BE PERFORMED BY STORE PERSONNEL) - INTERIOR .....</b>	<b>27</b>
<b>GENERAL CLEANING (BY TRAINED SERVICE PROVIDERS ONLY) .....</b>	<b>28</b>
<b>TROUBLESHOOTING (TO BE PERFORMED BY STORE PERSONNEL) .....</b>	<b>29</b>
<b>TROUBLESHOOTING (TO BE PERFORMED BY TRAINED SERVICE PROVIDERS ONLY) .....</b>	<b>30-31</b>
<b>TROUBLESHOOTING (BY TRAINED SERVICE PROVIDERS ONLY) - CONDENSING SYSTEM ....</b>	<b>32</b>
<b>TROUBLESHOOTING (BY TRAINED SERVICE PROVIDERS ONLY) - EVAPORATOR SYSTEM .....</b>	<b>33</b>
<b>PREVENTIVE MAINTENANCE (TO BE PERFORMED BY TRAINED SERVICE PROVIDERS ONLY) .....</b>	<b>34</b>
<b>PREVENTIVE MAINTENANCE: HONEYCOMB AIR DIFFUSERS (TO BE PERFORMED BY TRAINED SERVICE PROVIDERS ONLY) .....</b>	<b>35</b>
<b>SERIAL LABEL &amp; LOCATION / TECHNICAL INFORMATION / ADD'L INFORMATION .....</b>	<b>36</b>
<b>CAREL® CONTROLLER - PROGRAMMING THE INSTRUMENT.....</b>	<b>37</b>
<b>CAREL® CONTROLLER - USER INTERFACE, SUMMARY TABLES OF ALARMS &amp; SIGNALS ....</b>	<b>38</b>
<b>CAREL® CONTROLLER - Summary Table of Operating Parameters (After Programming Key) ..</b>	<b>39</b>
<b>SCC TECHNICAL SERVICE CONTACT INFORMATION &amp; LIMITED WARRANTY .....</b>	<b>40</b>

**OVERVIEW**

- These Structural Concepts merchandisers are designed to merchandise packaged products at 41 °F (5 °C) or less product temperatures.
- Product must be pre-chilled to 41 °F (5 °C) or less prior to being placed in merchandiser.
- Cases should be installed and operated according to this operating manual's instructions to ensure proper performance.
- Improper use will void warranty.

**TYPE I vs. TYPE II ENVIRONMENTAL CONDITIONS**

This unit is designed for the display of products in ambient store conditions where temperature and humidity are maintained within a specific range.

- Type I display refrigerators are intended for use in an area where environmental conditions are controlled and maintained so that the ambient temperature does not exceed 75 °F (24 °C) and 55% maximum humidity.
- Type II display refrigerators are intended for use in an area where environmental conditions are controlled and maintained so that the ambient temperature does not exceed 80 °F (27 °C) and 60% maximum humidity.

- If unsure if your unit is Type I or II, see tag next to serial label. See **SERIAL LABEL LOCATION & INFORMATION LISTED / TECH INFO & SERVICE** section in this manual for sample serial labels.

**COMPLIANCE**

- Performance issues when in violation of applicable NEC, federal, state and local electrical and plumbing codes are not covered by warranty.
- See below compliance guideline.

**WARNINGS**

- This sheet contains important warnings to prevent injury or death.
- Please read carefully!

**PRECAUTIONS, CORD/PLUG MAINTENANCE & WIRING DIAGRAM INFORMATION**

- See next page for **PRECAUTIONS, CORD/PLUG MAINTENANCE** and **WIRING DIAGRAM** information.



**COMPLIANCE**  
 This equipment **MUST** be installed in compliance with all applicable NEC, federal, state and local electrical and plumbing codes.



**WARNING**  
 Risk of electric shock. Disconnect power before servicing unit. **CAUTION!** More than one source of electrical supply is employed with units that have separate circuits. *Disconnect ALL ELECTRICAL SOURCES before servicing.*



**WARNING**  
 Hazardous moving parts. Do not operate unit with covers removed. Fan blades may be exposed when deck panel is removed. Disconnect power before removing deck panel.



**WARNING**  
 Condensate pan and overflow condensate pan is hot! Allow to cool before cleaning or removing from case.

**PRECAUTIONS**

- Following are important precautions to prevent damage to unit or merchandise.
- Please read carefully!
- See previous page for specifics on **OVERVIEW**, **TYPE**, **COMPLIANCE** and **WARNINGS**.

**WIRING DIAGRAM**

- Each case has its own wiring diagram folded and in its own packet.
- Wiring diagram placement may vary; it may be placed near ballast box, field wiring box, raceway cover, or other related location.

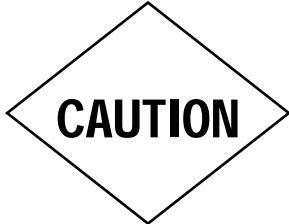

**CAUTION! LAMP REPLACEMENT GUIDELINES**  
 LED lamps reflect specific size, shape and overall design. Any replacements must meet factory specifications. Fluorescent lamps have been treated to resist breakage and must be replaced with similarly treated lamps.



**CAUTION! GFCI BREAKER USE REQUIREMENT**  
 If N.E.C. (National Electric Code) or your local code requires GFCI (Ground Fault Circuit Interrupter) protection, you **MUST** use a GFCI breaker in lieu of a GFCI receptacle.



**CAUTION! POWER CORD AND PLUG MAINTENANCE**  
 Risk of electric shock. If cord or plug becomes damaged, replace only with cord and plug of same type.



**CAUTION! ADVERSE CONDITIONS / SPACING ISSUES**

- Performance issues caused by adverse conditions are **NOT** warranted.
- End panels must be tightly joined or kept at least **6-inches** away from any structure to prevent condensation.
- Unit must be kept at least **15-feet** from exterior doors, overhead HVAC vents or any air curtain disruption to maintain proper temperatures.
- Unit must not be exposed to direct sunlight or any heat source (ovens, fryers, etc.).
- Tile floors, low ceilings or small rooms will increase noise level. Whisper Cool compressor blanket or remote unit may resolve noise level issues.
- Keep at least **8-inch** clearance above unit for air discharge (self-contained units only).

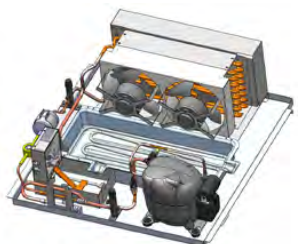

**CAUTION! CHECK CONDENSATE PAN**  
 Water on flooring can cause extensive damage!  
 Before powering up unit, check the following:

- Condensate pan **MUST BE** positioned directly under condensate drain.
- Overflow pan plug **MUST BE** securely plugged into receptacle.

## SHIPPING BRACKET REMOVAL / TOE-KICK REMOVAL / REMOVING CASE FROM SKID

### 1. Removing Shipping Brackets Attached To Skid

- Remove screws holding case shipping brackets to skid.
- Remove case shipping brackets from skid.
- See illustrations at right. Note: Shipping brackets will vary in size, shape, material and location depending upon case type and model.

Various Types Of Shipping Brackets Shown With

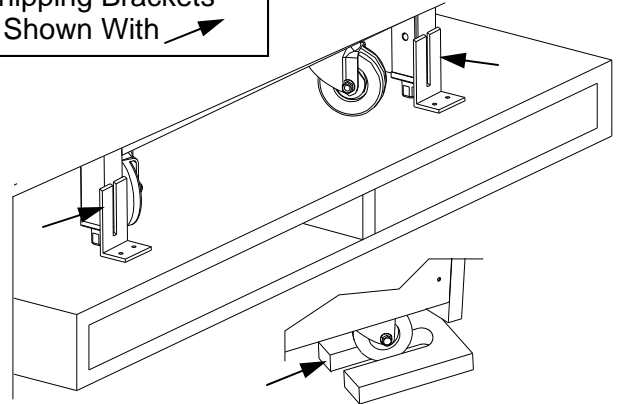

### 2. Remove Front / Rear Toe-Kicks Before Removing From Skid

- Toe-kicks are normally shipped separately.
- If toe-kicks are attached to case, they must be removed.
- Toe-kicks may be attached to case via slot / magnet method.
- Remove toe-kick by pulling away from lower magnet and lifting up and off hooks.
- No screw removal is required.
- See illustrations at mid-right.

### 3. Remove Case From Skid

- To prevent damage, support case while sliding it toward edge of skid ).
- IF NO CASTERS ARE ON SKID, tip case slightly back and slide skid from underside of case. When case is at edge of skid, carefully lower to floor (so two levelers rest on floor).
- IF CASTERS ARE ON CASE, it may be rolled off skid via ramp (as shown in lower-right illustration).
- Carefully slide skid out from under case.
- After removal of case from skid, place into position.
- Note: Illustration below-right reflects general outline of sample case and does not reflect any particular model or options).

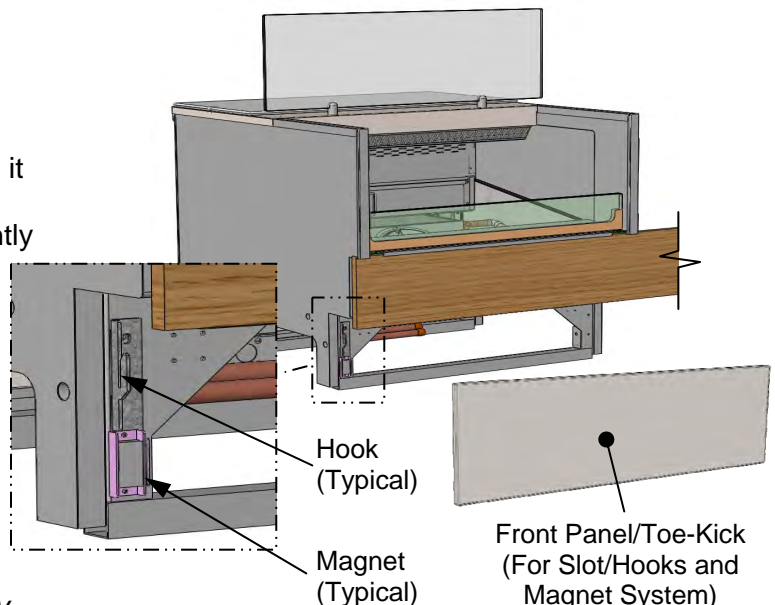

### 4. Position/Align Case Alongside Other Cases

- If lineup requires it, be sure to position/align your case alongside adjoining cases before adjusting levelers or shimming frame support rails.
- Also, see next page for instructions on caulking, sealing and bolting to adjoining cases prior to adjusting levelers or shimming frame support rails.
- This may require the repositioning of the case you are installing or the already positioned cases.

Note: View at Right Shows Partially Disassembled Case For Illustrative Purposes Only.

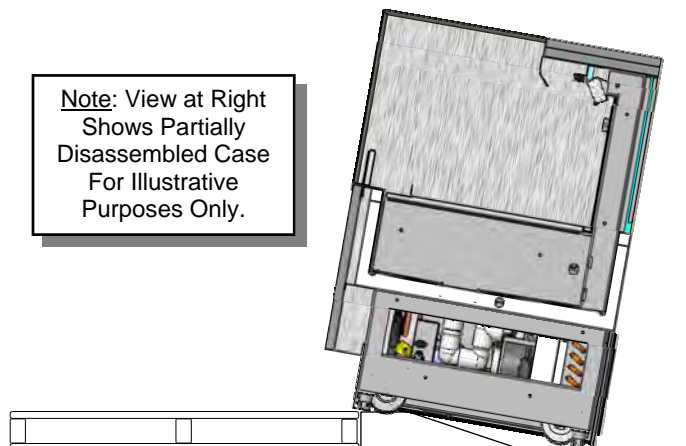

## CAULKING / SEALING / BOLTING ADJOINED UNITS

### Caulking, Sealing, Bolting Adjoined Units

*Note: Your model's features or options may vary from illustration shown below, but general guidelines apply.*

Warranty will be voided if improper sealant is used. Lay a generous bead of caulk/sealant as specified below.

- Use Industrial grade butyl caulk on non-visible areas.
- Use industrial grade silicone sealant on visible areas.
- Form Two (2) Caulk/Sealant Lines: Sanitation and Refrigeration (see illustrations below).
- Caulking/sealing tub prevents air from escaping thru seams between cases (which may cause condensation problems and reduced refrigeration efficiency).
- Caulking/sealing also prevents water from seeping between cases to the floor.
- Note: Place thicker bead of caulk around drain.
- Bolt Holes are locations shown below.
- Use 1/4-20 x 1.00" bolts and accompanying nuts.
- Remove deck pan assembly to access holes 3, 4 & 5.

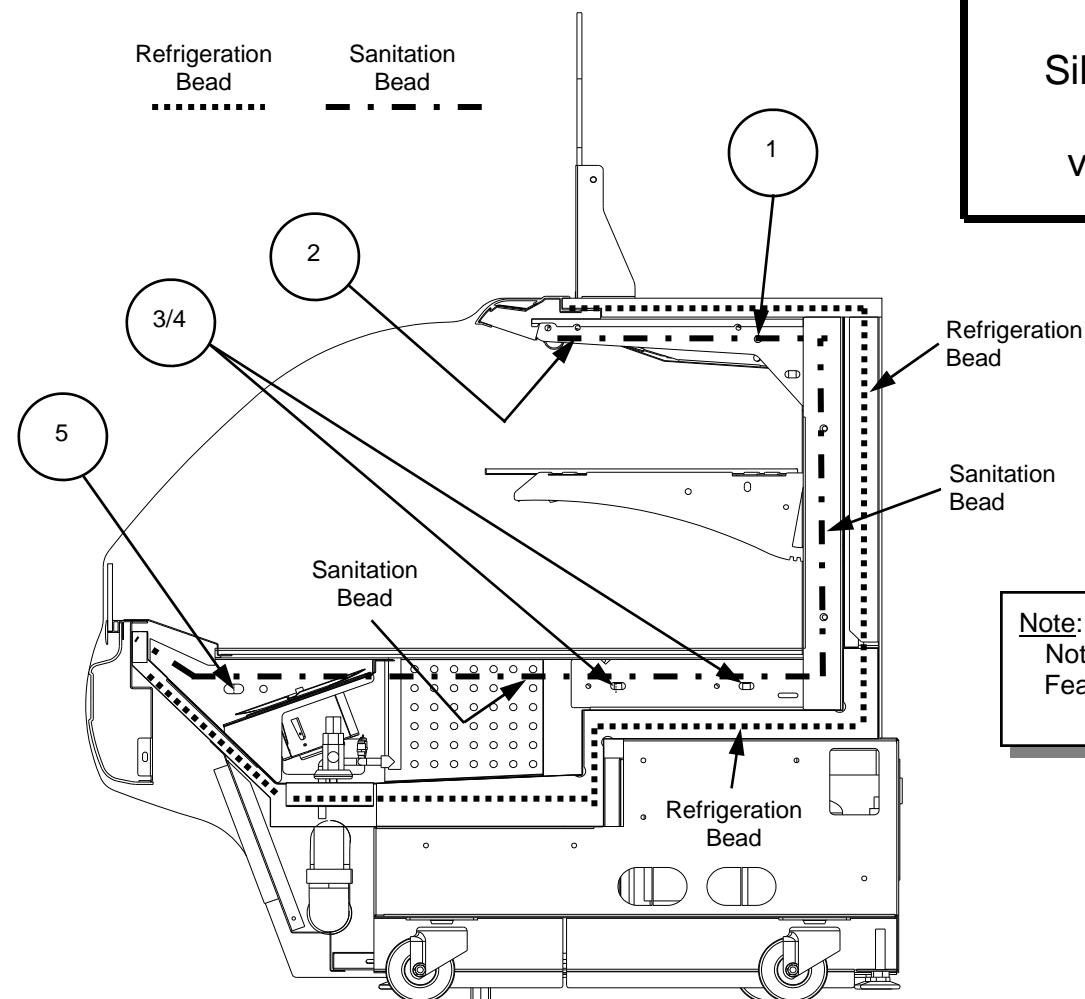

### Note

Butyl is to be used on non-visible areas.

Silicone is to be used on visible areas.

Note: Illustrations Shown May Not Exactly Reflect Every Feature or Option of Your Particular Case.

## SHIMMING FRAME SUPPORT RAILS / ADJUSTING LEVELERS

### **1. Cases With Frame Support Rails: Shim**

- Illustration at top-left shows case with frame support rails.
- Shims will be provided on cases with frame support rails.
- Use shims to level case.

### **2. Cases With Levelers: Adjust**

- After case is in position, adjust case so it is level and plumb.

- You may need to remove front and/or rear toe-kick to access levelers.
- Use adjustable wrench (and possibly a pry bar) to adjust leveler.
- Do not use pry bar on toe-kick (it may buckle).
- Do not use pry bar on end panel (it may chip).
- Use pry bar ONLY on base frame to avoid damaging case.
- Use a block to reach base frames with pry bar.
- See below-right illustrations.

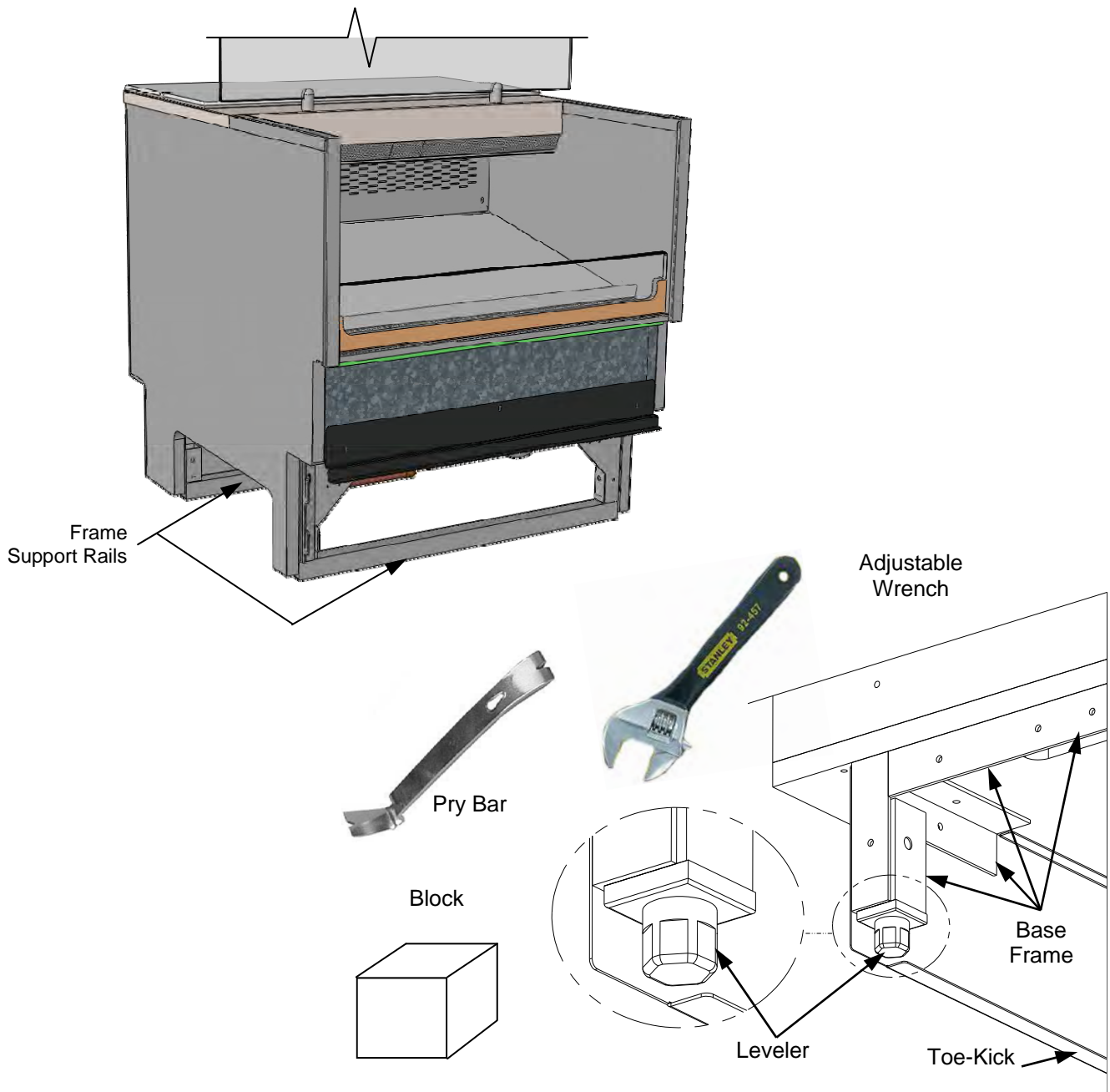

**1. Merchandiser Start-Up**

- Do not use an extension cord with this appliance.
- Do not operate this equipment with a damaged cord, plug or outlet.
- Insure that the main power switch is off.
- Plug cord into a certified 110V electrical outlet with ground.
- Turn main power switch on (see location at rear of case in illustration below)
- Coil fans should turn on.
  - From inside of the case, check for discharge air from front baffle, to confirm that the fans are functioning properly.
- When the case is in a start-up mode or has been idle for a long period of time, unit may require 75 minutes running time to pull-down temperature.
- Turn lights on.
  - Light switch is next to main power switch.
  - The lights should come on at the same time.
- Always maintain front and rear airflow clearance of twelve inches.
- Obstruction or restriction of air can void warranty.

- Thermometer is also at case rear (as shown below), and controls internal case temperature.
- Interior case temperature is to be 35 °F to 41 °F.
  - **Note:** Case temperature is determined by case size. Temperature is controlled by a thermostat. If a temperature setting change is required, refer to instructions in Temperature Controller Programming sections of this manual.
- **Note:** Set point should be 40 °F. This will maintain product temperature range. Settings lower than 40 °F can cause food items to freeze.

**2. Removable, Condenser Coil Filter**

- A removable filter prevents impurities (dust, dirt and debris) from entering condenser coil.
- Filter must be removed weekly and cleaned.
- See **GENERAL CLEANING (TO BE PERFORMED BY STORE PERSONNEL) - EXTERIOR** in this operating manual for cleaning instructions.

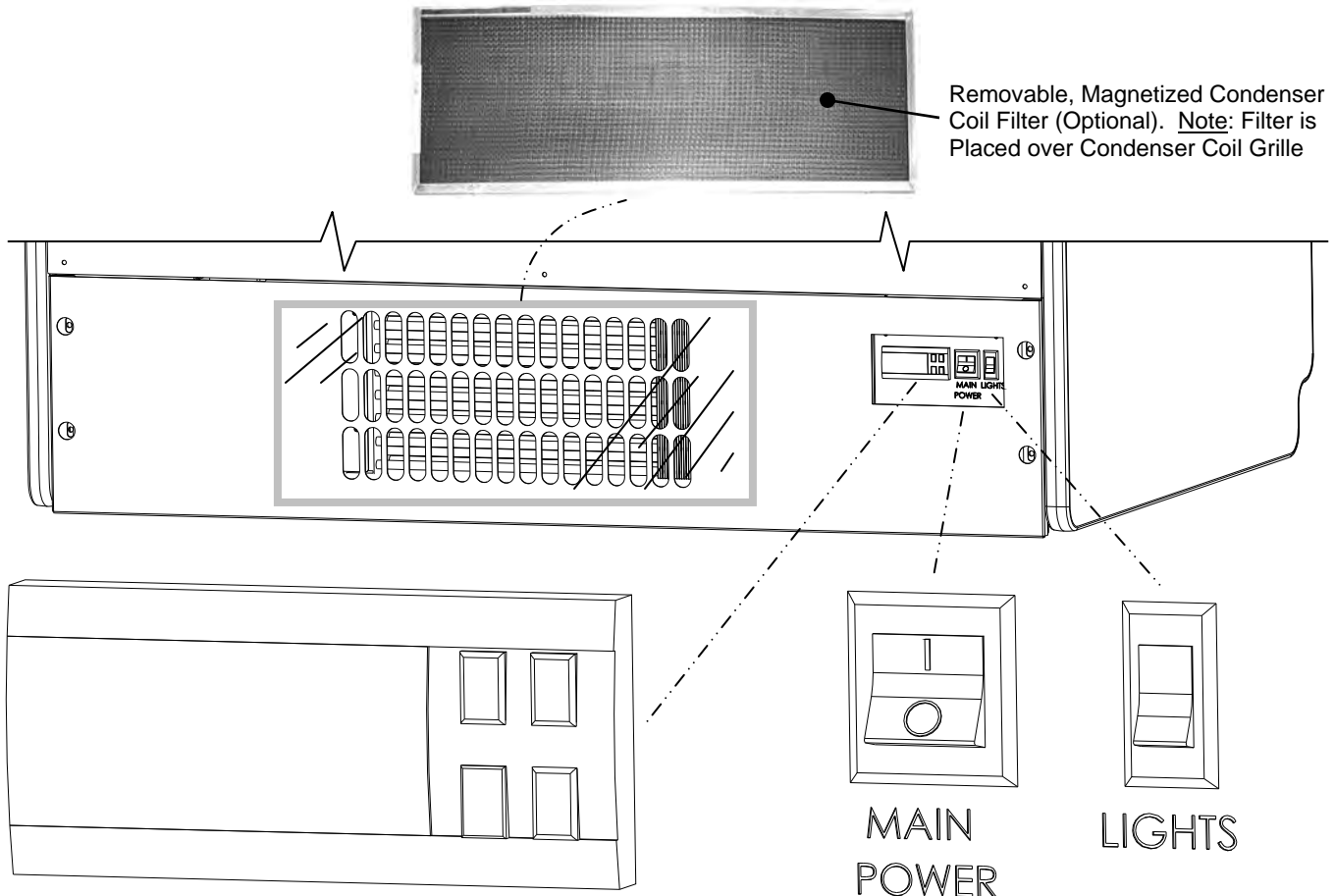

**1. Product Placement**

- Product can be placed on decking or steps (risers) within self-service display area.
- A wide range of product may be displayed.

**2. Honeycomb Airflow Consideration**

- Airflow from honeycomb air diffuser is designed to flow over (and around) product to return air grille at case front.
- Caution! You must keep the honeycomb air diffuser unblocked by product for airflow to reach return air grille.
- Caution! You must ALSO keep product OFF return air grill at case front.
- See illustration below.

**3. Load Lines**

- Load lines represent the maximum height that product can be placed and/or stacked in case.
- Keep product at or under load lines to assure that refrigerated airflow is properly cycled from honeycomb air diffuser through the return air grille.
- Proper product placement will maintain acceptable product temperature.
- See illustration below.

Note: Perspective View of Model CO4836RG.5716 Is Shown At Right And May Not Exactly Reflect Every Feature or Option of Your Particular Case.

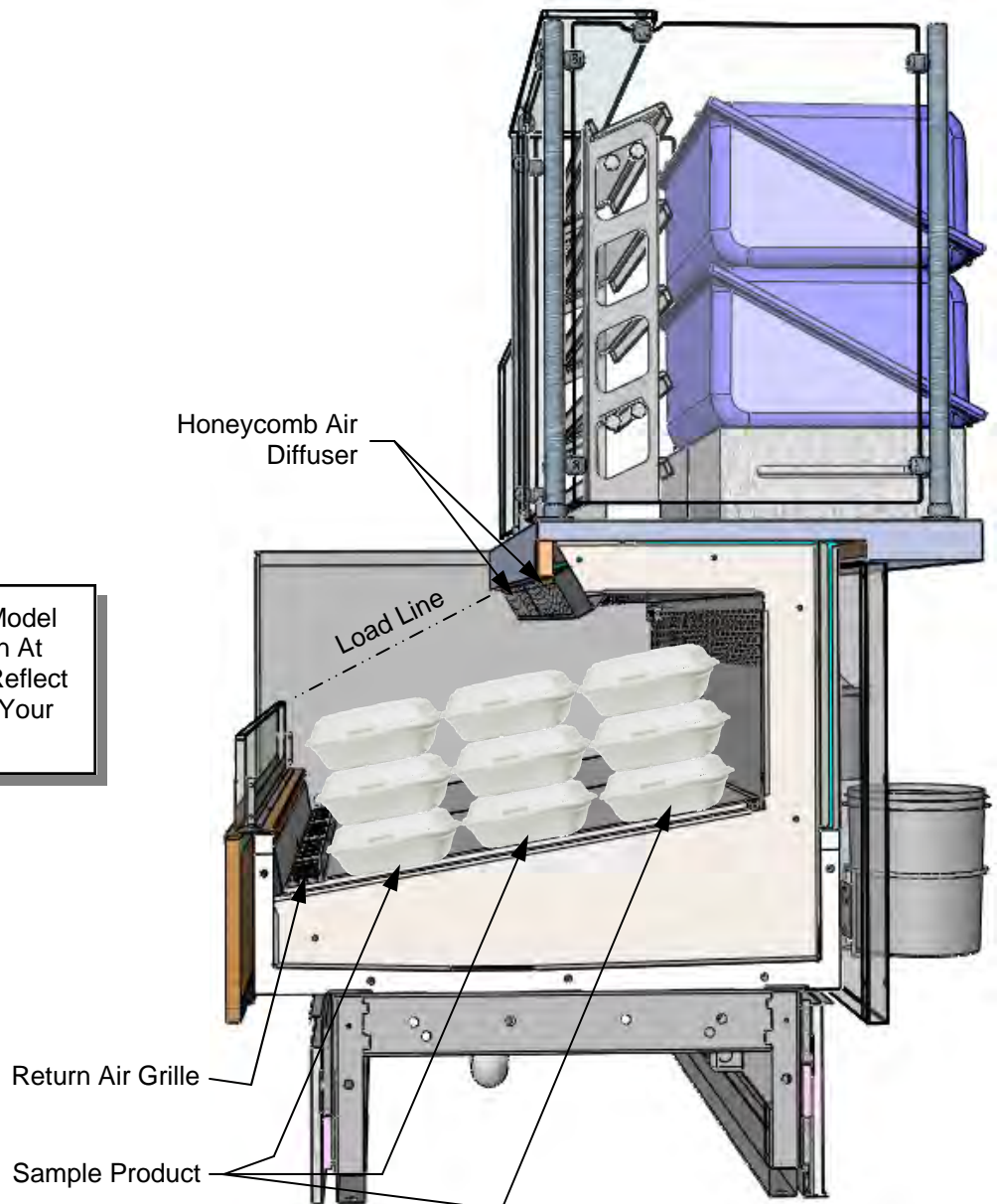

**1. Adjustable Front Toe-Kick (Models CO33R, CO43R, CO53R, CO63R, Etc.)**

- Front toe-kick is adjustable.
- Loosen screws holding front toe-kick in place.
- Lower front toe-kick to floor.
- After case is in desired position, use silicone sealant to seal toe-kick to floor.
- See next page for removable front panel (without screws) for models CO3434RG.5716, CO3034RG.5718 and CO3034RG.5718A

**2. Light Fixture**

LED light fixture is at upper section of case as shown in illustration below.

**Note:** Illustrations Shown May Not Exactly Reflect Every Feature or Option of Your Particular Case.

- LEDs rarely require change-out.
- See next page in this manual for more specifics.

**3. Night Curtain**

Optional night air curtain is near honeycomb.

- See **OPTIONAL NIGHT AIR CURTAIN OPERATING INSTRUCTIONS** section in this manual for more specific illustrations.

**4. Honeycomb Air Diffuser**

See **PREVENTIVE MAINTENANCE - HONEYCOMB (BY TRAINED SERVICE PROVIDERS ONLY)** section in this manual for complete information.

**5. Thermometer**

- Thermometers provide internal air temperature only (not actual food temperature).
- Use probe thermometers to determine actual product temperatures.

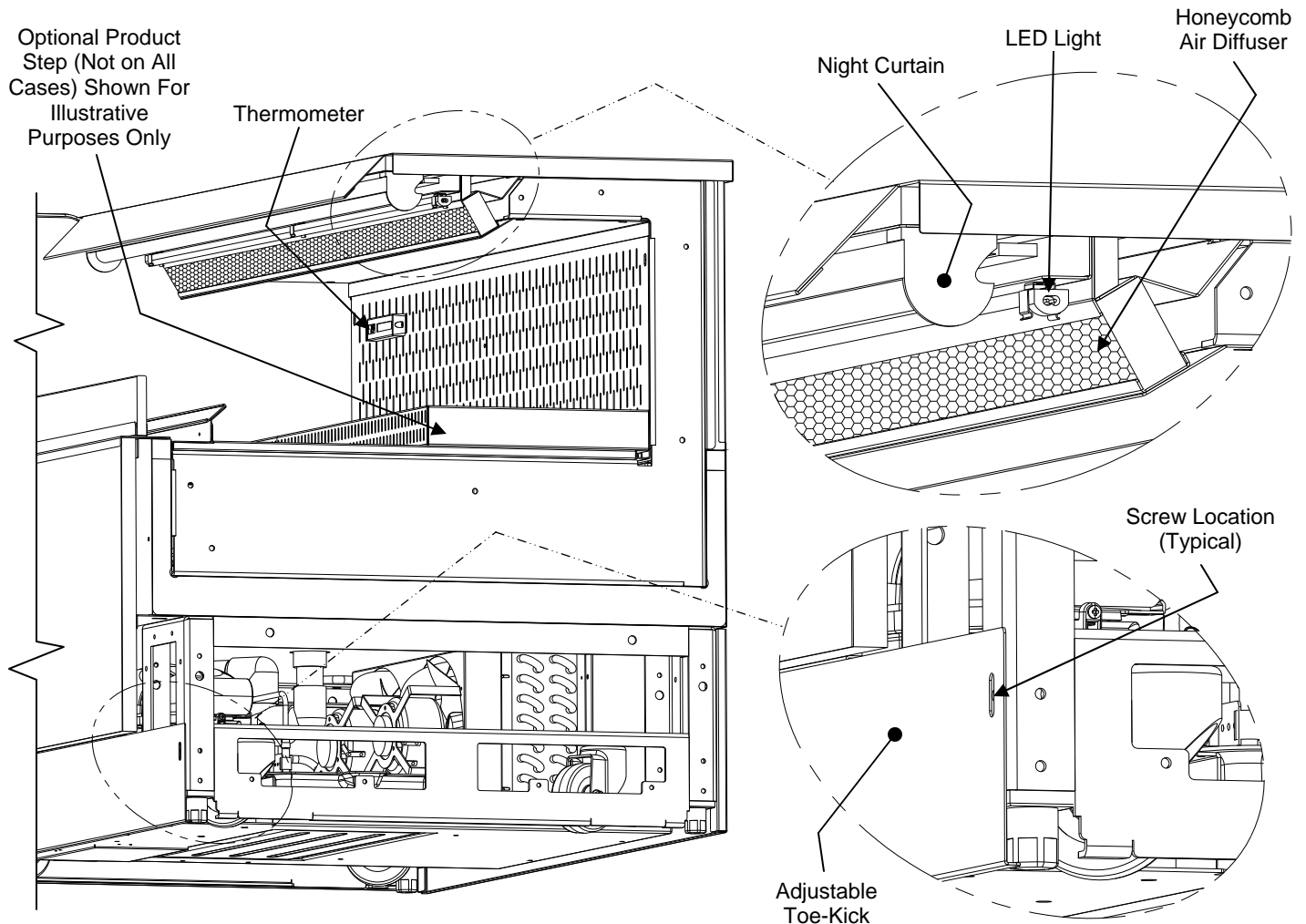

### 1. Removable Toe-Kicks

- Front toe-kick is removable.
- Simply lift up and off.
- After case is in desired position, use silicone sealant to seal toe-kick to floor.
- See previous page for adjustable front toe-kicks (with screws) on models CO33R, CO43R, CO53R, CO63R, etc.
- See next page for magnetic removable front panels.

### 2. Product Risers (aka "Steps")

- Risers ("steps") allow product to be more prominently displayed.
- Risers are to rest on decks and be placed as far back as possible (up against rear plenum) as shown in illustration below.
- See **GENERAL CLEANING (TO BE PERFORMED BY STORE PERSONNEL) - INTERIOR** in manual for instructions on cleaning risers/steps.

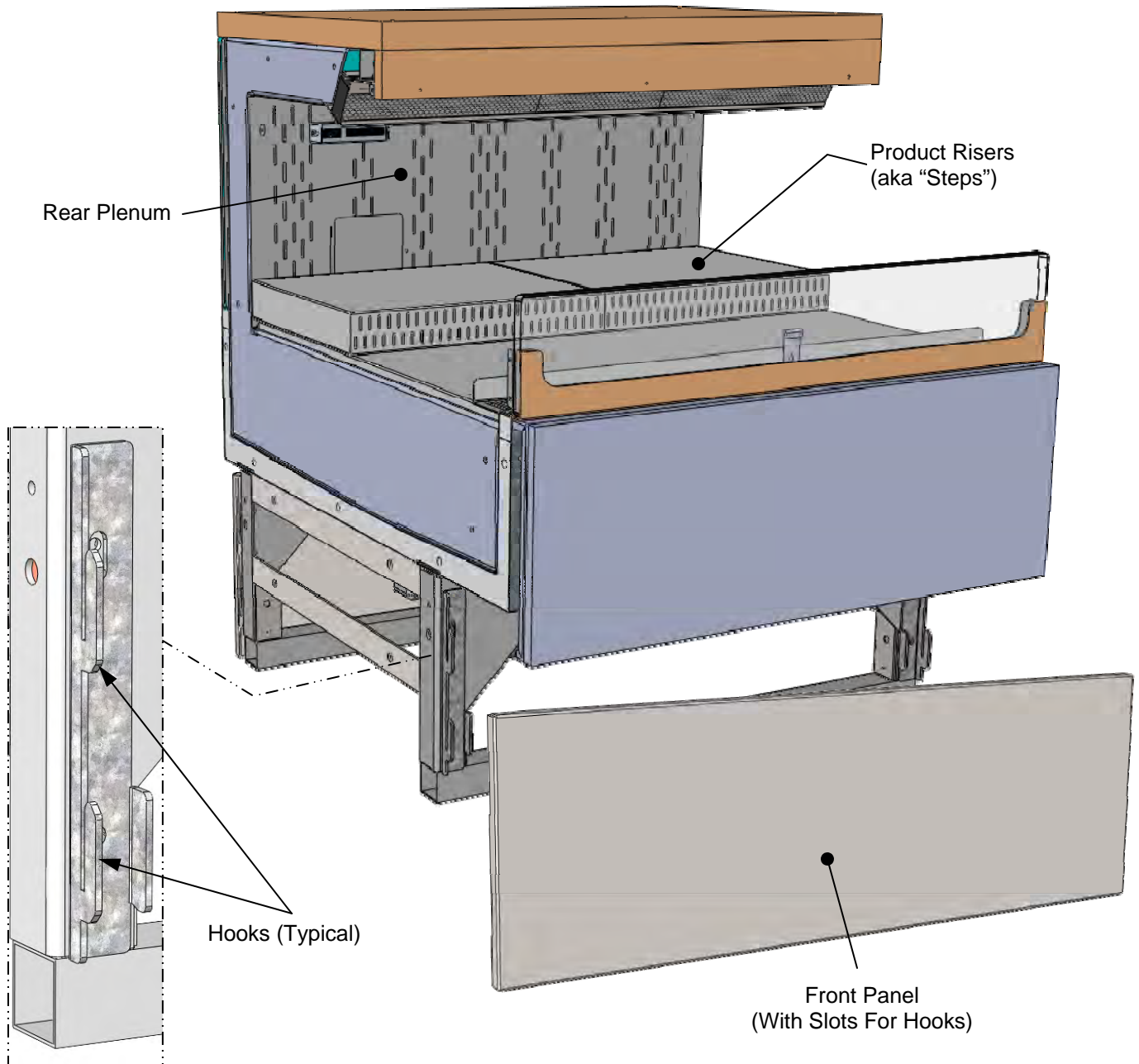

## MAINTENANCE - REMOVABLE FRONT TOE-KICKS (MAGNETIC SYSTEM)

### ***Removable Magnetized Front Panels***

- These panels are found on models CO3434RG.5716, CO3436RG.5716, CO3034RG.5718 and CO3034RG.5718A
- Toe-kicks are shipped separately.
- Toe-kicks are to be placed on case via slot/magnet attachment method.

- Remove toe-kick by pulling away from lower magnet and lifting up and off hooks.
- No screw removal is required.
- See illustrations below
- See previous page for slot/hook removable front panels.

Note: Illustrations Shown May Not Exactly Reflect Every Feature or Option of Your Particular Case.

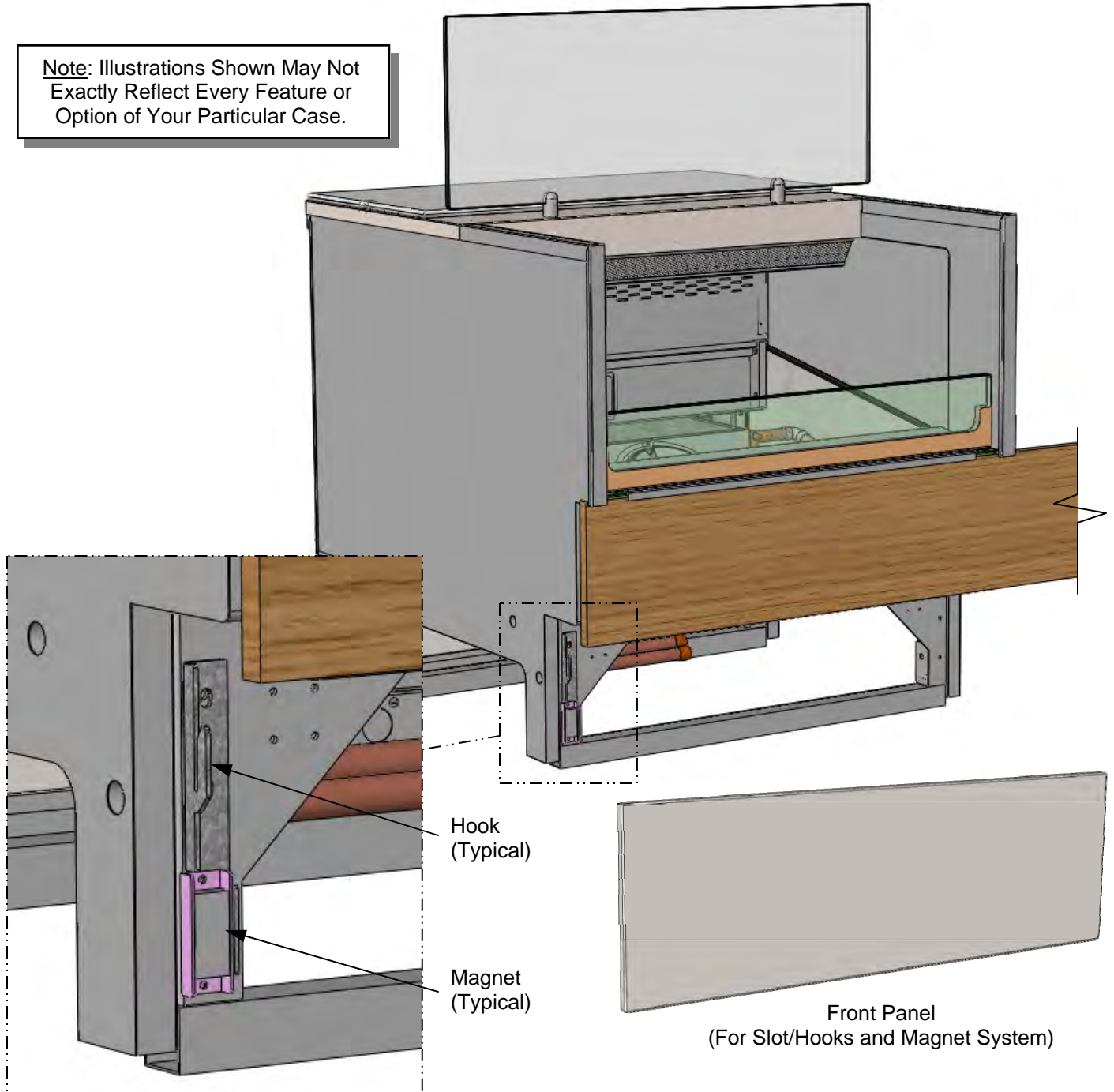

**1. LED Light Fixtures (Location / Switch)**

- LED light fixture is located at top of case.
- Light switch is located at case rear.
- See illustration below.

**2. LED Light Fixture Repair / Removal / Replacement**

*Repair of Lamp:*

- Plug can come loose from LED light socket.
- Simply insert firmly and check that it is securely held in place.

*Removal of Lamp:*

- This case is provided with LED lights which will rarely require change-out.
- Contact Structural Concepts' Technical Service Department for replacement parts (see Technical Service section of manual).

*Replacement of Lamp:*

- To replace LED Light Fixture, disconnect the existing LED light from its brackets. Replace.
- **Note:** LED plug must be connected in specific manner or they will not work.
- Oval form of plug must connect to oval form of LED light. See below-left photos.

**3. LED Power Supply / Ballast Access (Service Technicians Only!)**

- See **ELECTRICAL ACCESS AND COMPONENTS** section in this manual for illustration.

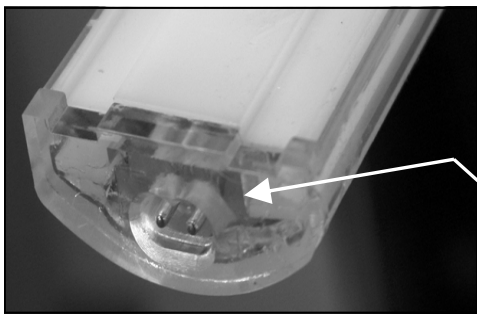

LED's Oval Form (Typical)



Plug's Oval Form (Typical)

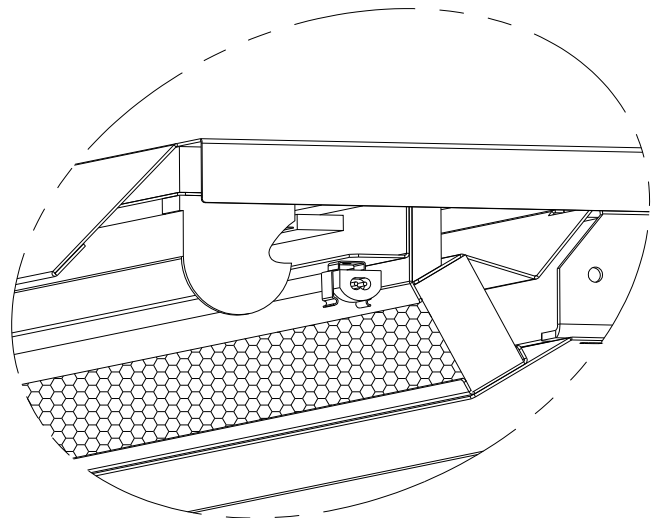

Optional Product Step (Not on All Cases) Shown For Illustrative Purposes Only

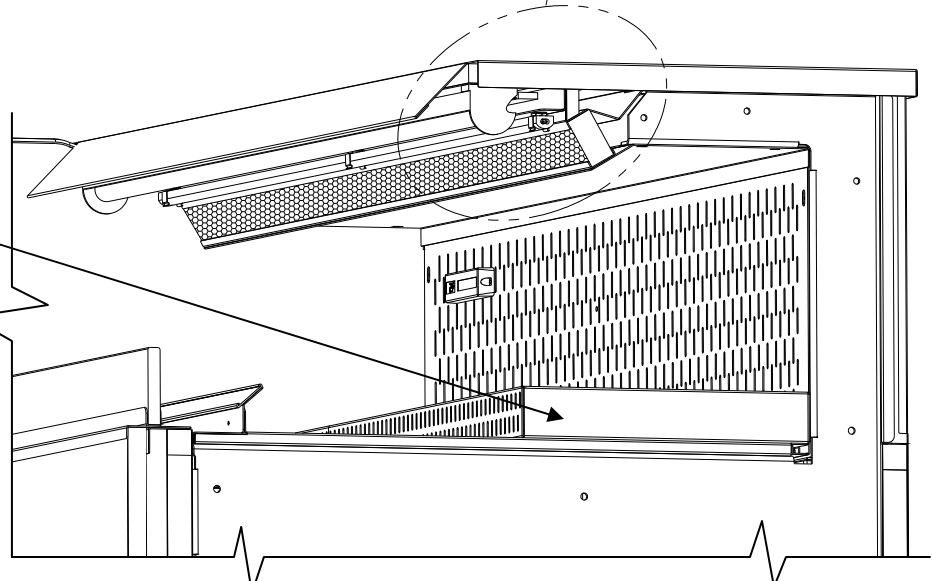

**Note:** Illustrations Shown May Not Exactly Reflect Every Feature or Option of Your Particular Case.

**Night Air Curtain Installation & Operating Instructions**

1. Use caution when handling night air curtain.
2. Display case may come with night curtain already attached. If not, a retrofit kit will be provided. If using SCC-supplied retrofit kit, attach to display case by centering night curtain along top-front of case as shown in illustration below. Attachment magnets will hold night air curtain firmly in place.
3. Grasp the handle and pull downward to desired location in front of case (as shown in illustration below).
4. To return night air curtain to its retracted position, grasp handle, lift up and away from its magnetic attachment and carefully wind night air curtain back into roll.
5. **Caution!** Do not allow spring-loaded night air curtain to freely snap back into roll. Doing so can eventually destroy night air curtain's tension and retractability.
6. To entirely detach night air curtain from case, simply pull it downward and away from case. Caution! Do NOT drag night air curtain along top (underside) of case or magnets may scratch or mar surface. Simply lift night air curtain downward and away from case. Store in safe place away from foot-traffic.
7. Store in a safe and secure space until needed again.

**NOTE: THE BELOW ILLUSTRATION MAY NOT EXACTLY REFLECT EVERY PARTICULAR CASE'S FEATURES OR OPTIONS.**

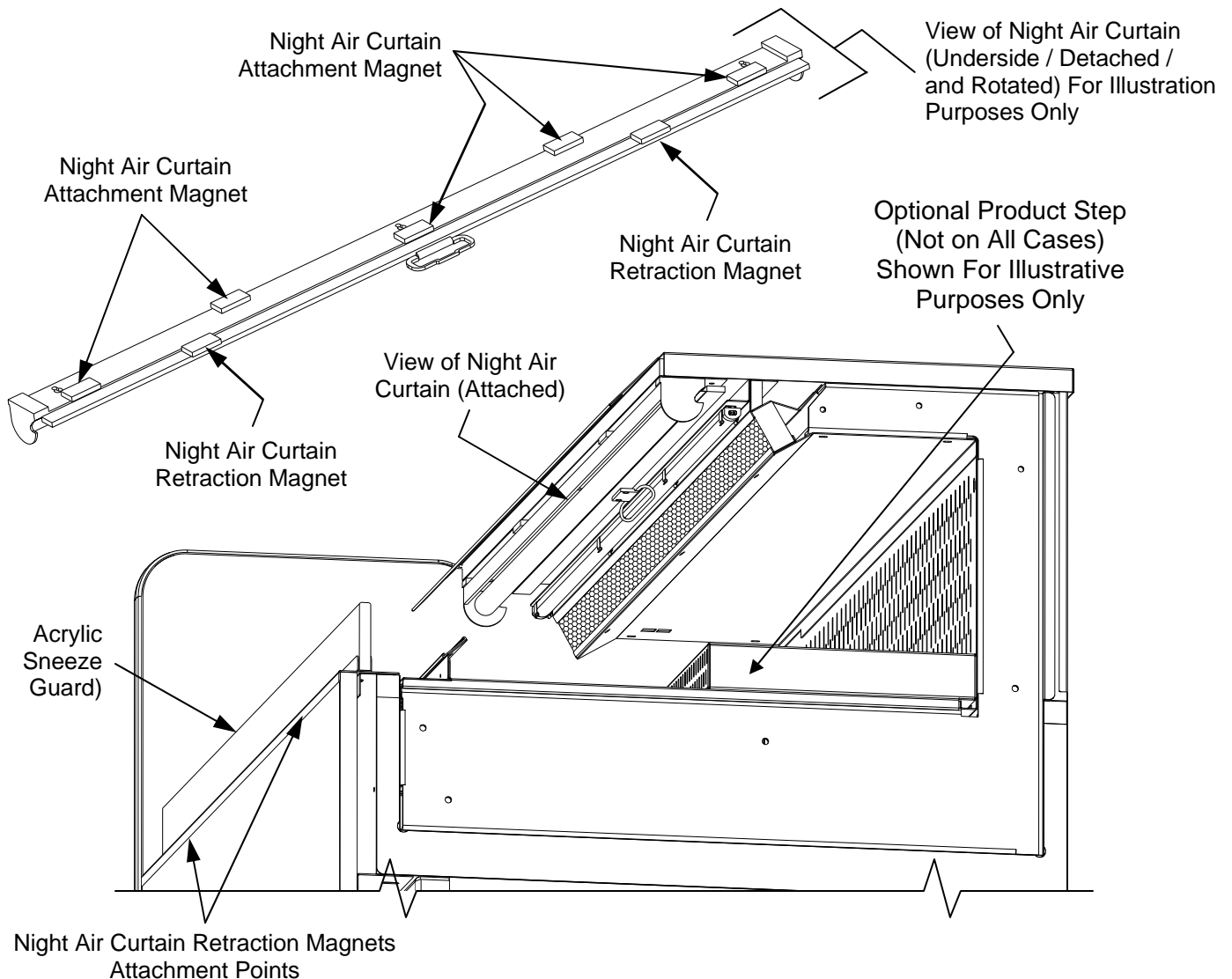

### Electrical: Access and Components

**Warning, disconnect power before providing maintenance and service to unit.**

#### 1. Ballast Access

- A 6 1/2" space is provided at case rear to access electrical components (between refrigeration package and temperature controller plate).
- Electrical components such as terminal block, contactor, and ballast are in main electrical box.

#### 2. Temperature & Defrost Control

- The case temperature is set at the factory, as determined by the case size. The temperature is controlled by a thermostat. If a temperature setting change is required, follow the instructions in the Temperature Controller section of manual.
- If service is required to the temperature control unit, call Structural Concepts. This maintenance should be performed by a certified technician.

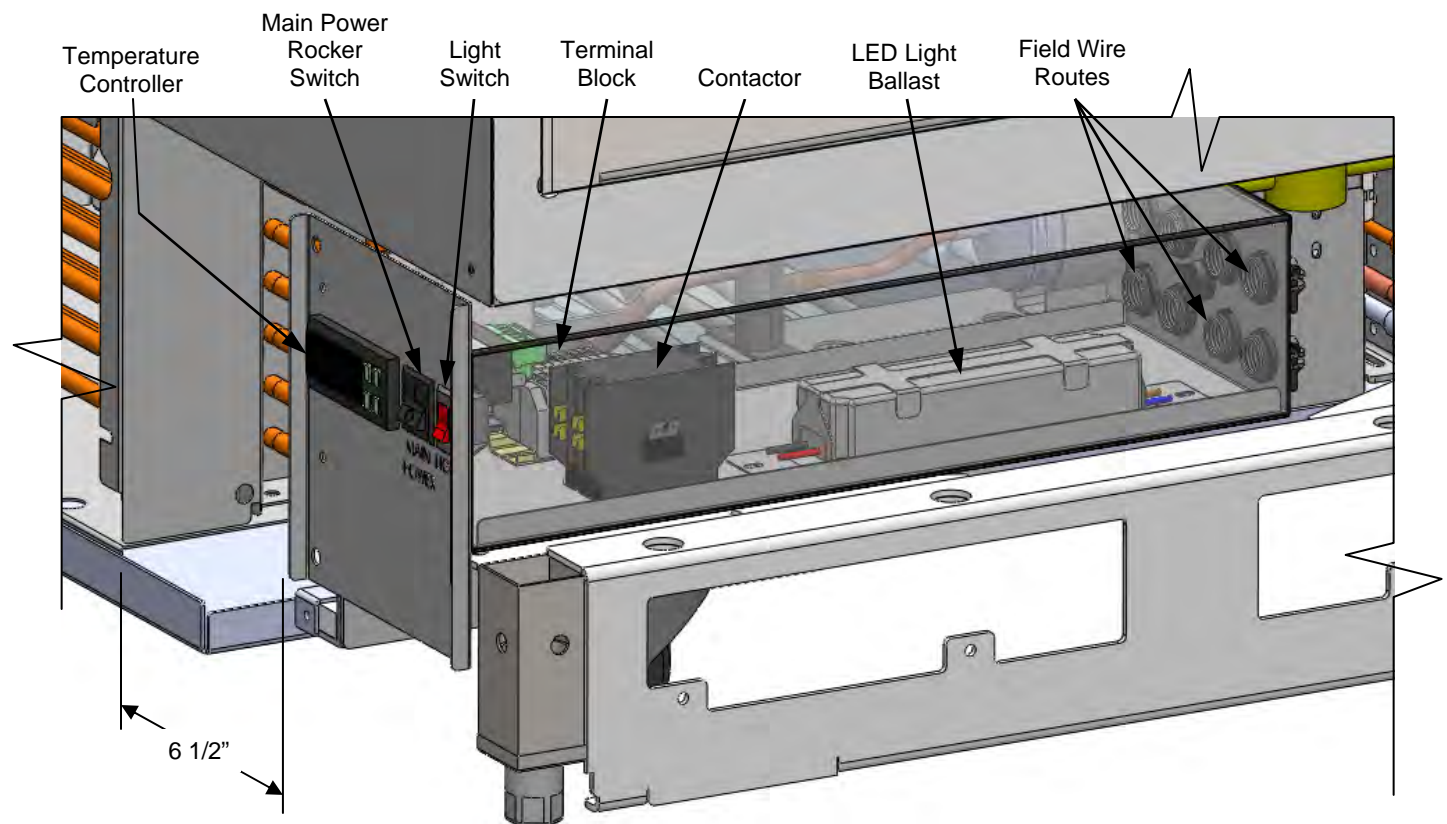

**Note:** Illustrations Shown May Not Exactly Reflect Every Feature or Option of Your Particular Case.

## MAINTENANCE - REAR COMPONENT LAYOUT (MODEL CO3436RG.5716 ONLY)

### 1. Vertical Glass Divider / Sneeze Guard

- Vertical glass divider/sneeze guard is held securely with mounts. **DO NOT** lean against or strike glass or it could snap off mounts or break.

### 2. Removable 18" Sanalite® Wrapping Board

- Sanalite® wrapping board is at case rear.

### 3. Salad Tissue Box Holder

- Salad tissue box holder is at rear-right.

### 4. Sandwich Wrap Holder

- Sandwich wrap holder is at rear-center.

### 5. Removable Writing Instrument Cup

- Pens and markers are used for writing on wrapped products.
- **Note:** Writing instruments are to be wiped off with sanitary wipes **AFTER EACH USE**.

### 6. Removable Sanitary Wipe Bucket

- Sanitary wipes are designed to wipe off writing instruments after each use.

### 7. Removable Rear Panel

- Rear panel is removable for cleaning purposes.
- Simply remove six (6) Phillips® screws.
- Carefully lift off case rear.

### > Removable Holders (From Rear Panel)

- Salad tissue box holder and sandwich wrap holders can be lifted up and off case rear for cleaning purposes. See illustrations below.

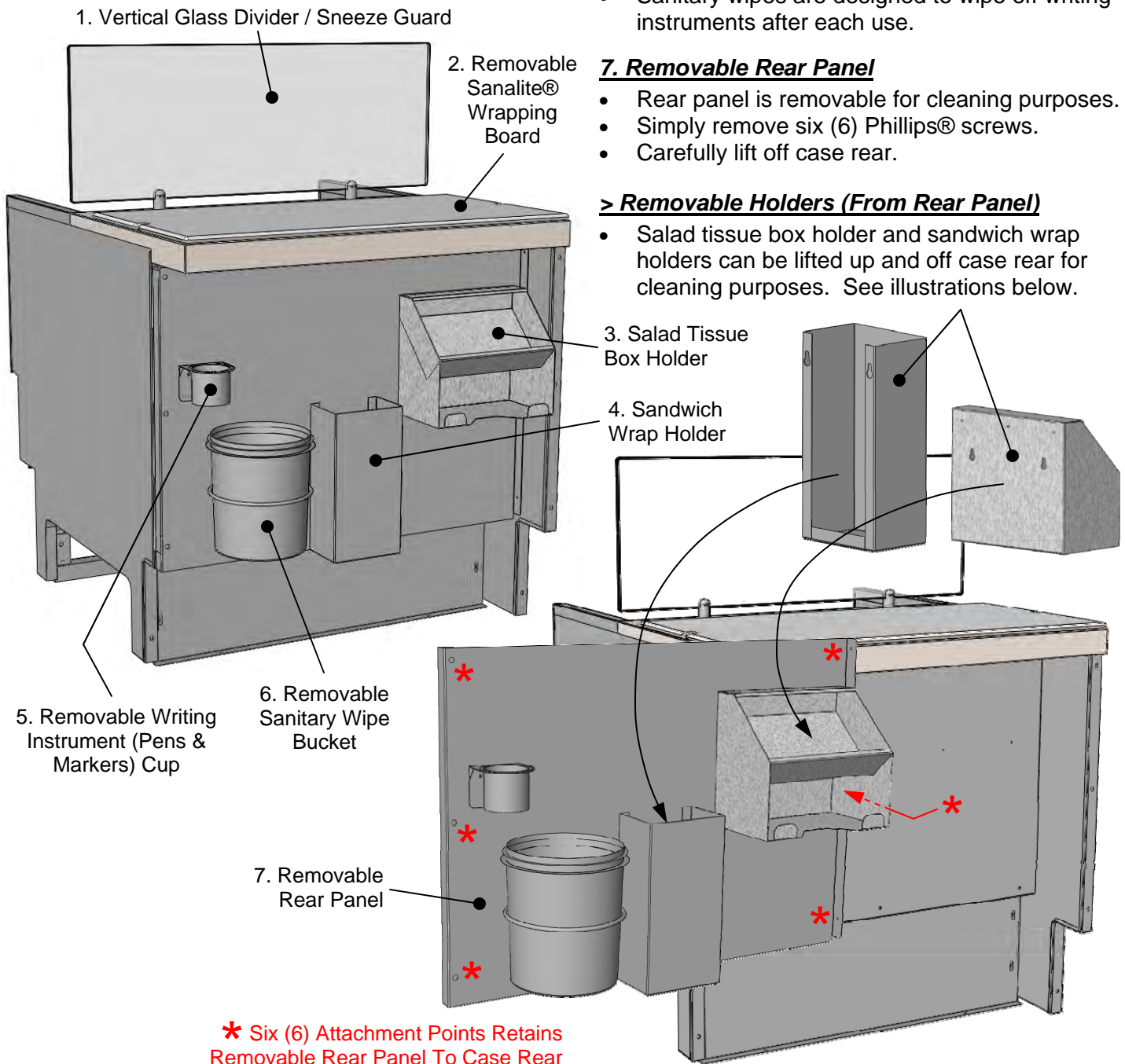

**1. Security Cover (Optional)**

- Security covers are designed to prevent access to merchandiser.
- Security cover is to be placed OVER upper latch retaining clip and UNDER lower latch retaining clip.
- Handles allow security cover to be lifted up and off.

**2. Locking Mechanism**

- Locking mechanism key allows plate cam lock to be rotated under upper retaining clip.
- Proper rotation of plate cam lock prevents cover from being removed.

**3. Key Storage / Cover Storage**

- When security cover is attached to case, remove keys and store in easy-to-remember, yet secure location.
- When security cover is removed from case, store in safe, secure location away from foot traffic.

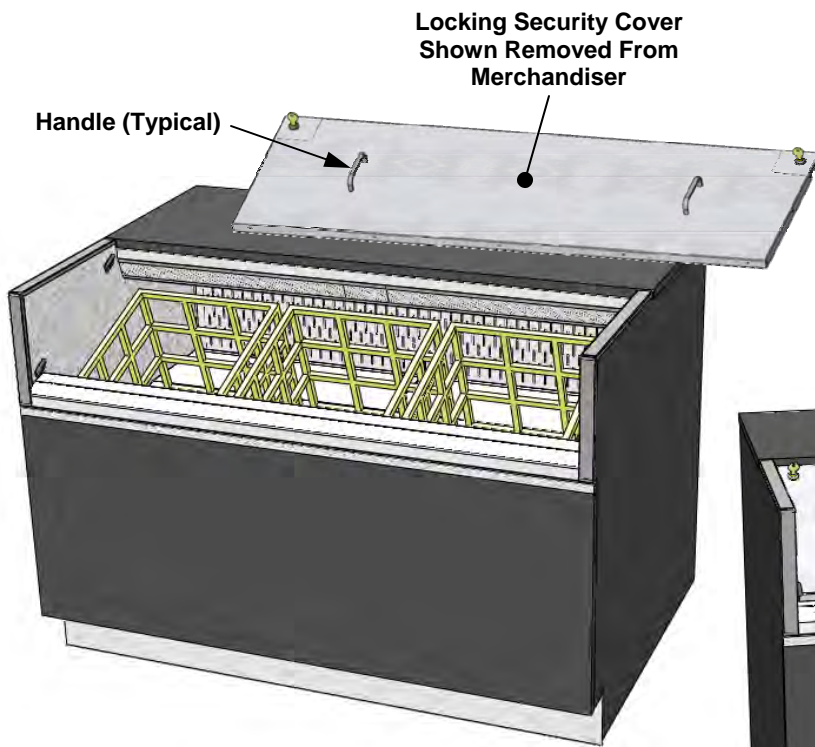

**Model CO43RM Under Counter Unit With Optional Locking Security Cover Removed**

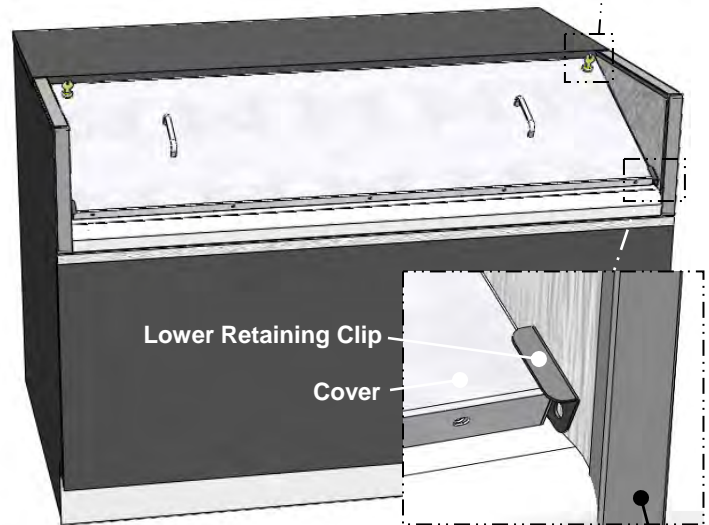
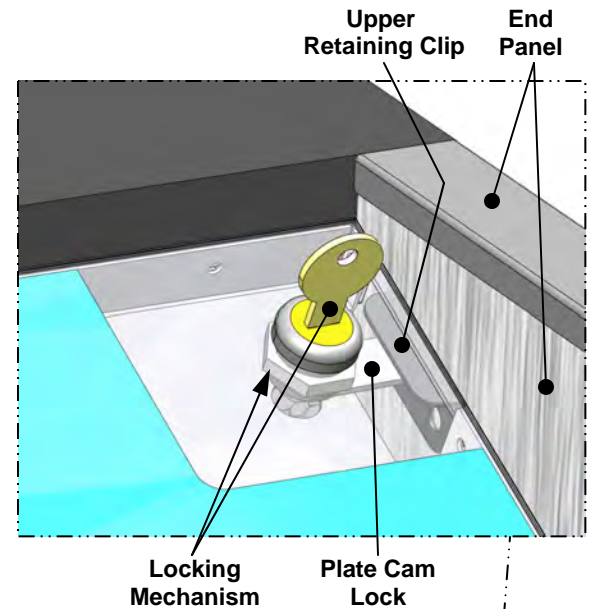

**Model CO43RM Under Counter Unit With Optional Locking Security Cover Intact**

**1. Merchandiser Overview**

- Model CO4836R.5716 and CO4836RG.5716 also have a bread display unit that sits atop counter and is protected by a glass sneeze guard. This bread display unit is also separately manufactured by SCC as Model BDXXXX.
- Stainless steel posts hold sneeze guards in position.
- Sneeze guards are glass (sides and top).
- Acrylic bread bins and bread display supports are removable.

- Stainless steel brackets suspend bread display.
- Stainless steel removable wrap cubbies are accessible at case rear.
- See illustration below.

**2. Rear Panel Removal (For Cleaning Purposes)**

- See **MAINTENANCE - REAR COMPONENT LAYOUT (MODEL CO3436RG.5716 ONLY)** section in this manual for location of the six (6) rear panel attachment points.
- Removing screws at these attachment points will allow entire rear panel to be removed from case.

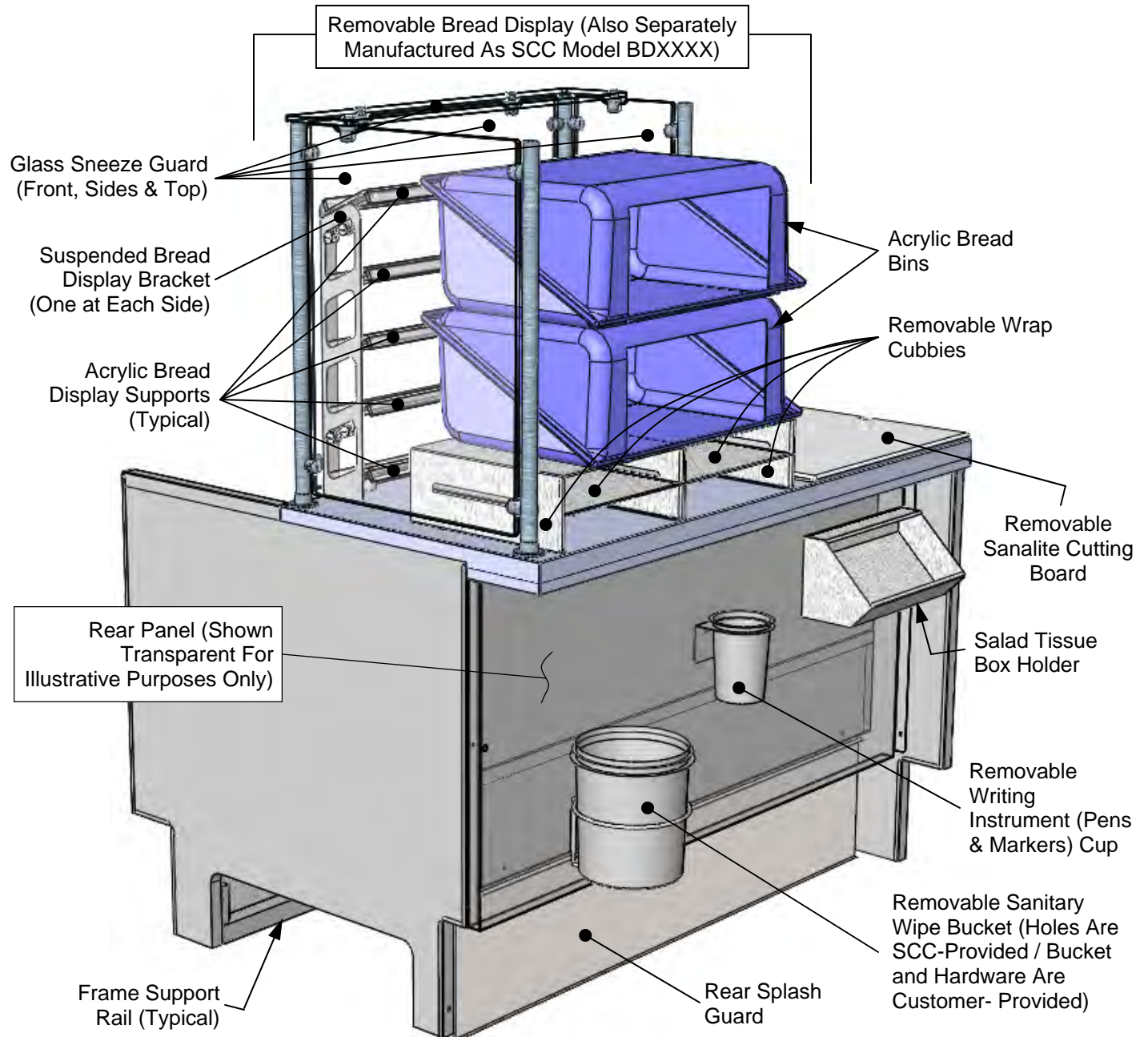

**1. Evaporator Fan Access**

- Remove lower decking.
- Lift decks straight up and out to avoid scratching insides of case while removing decks.

**3. Drain**

- Drain is located at center of tub (under evap. fan).
- Access to drain may also be gained by removing evaporator fan shroud.

**2. Thermostatic Expansion Valve Access**

- TXV also becomes accessible upon removal of decking.

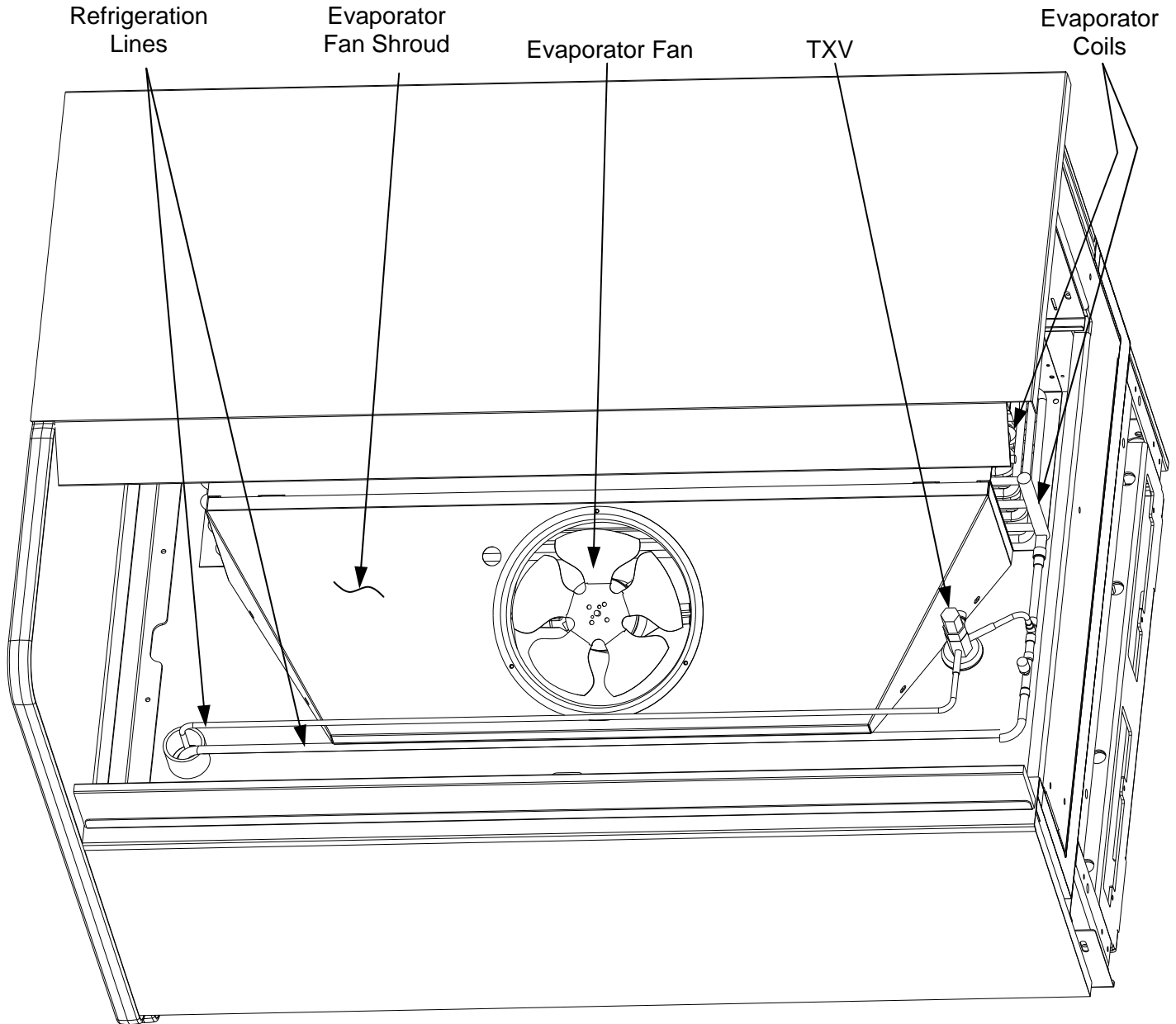

Above Illustration Shown With End Panel and Decking Removed For Illustrative Purposes

## REFRIGERATION - EVAPORATOR AREA: MODELS CO43RM / CO63RM (AND SIMILAR UNITS)

### 1. Evaporator Fan Access

- Remove milk crates and lower decking.
- Lift decks straight up and out to avoid scratching insides of case while removing decks.

### 2. Thermostatic Expansion Valve Access

- TXV is accessible upon removal of decking.
- See illustration below.

### 3. Drain

- Drain is located at center of tub (under TXV).
- Access trough by removing evaporator fan shroud.

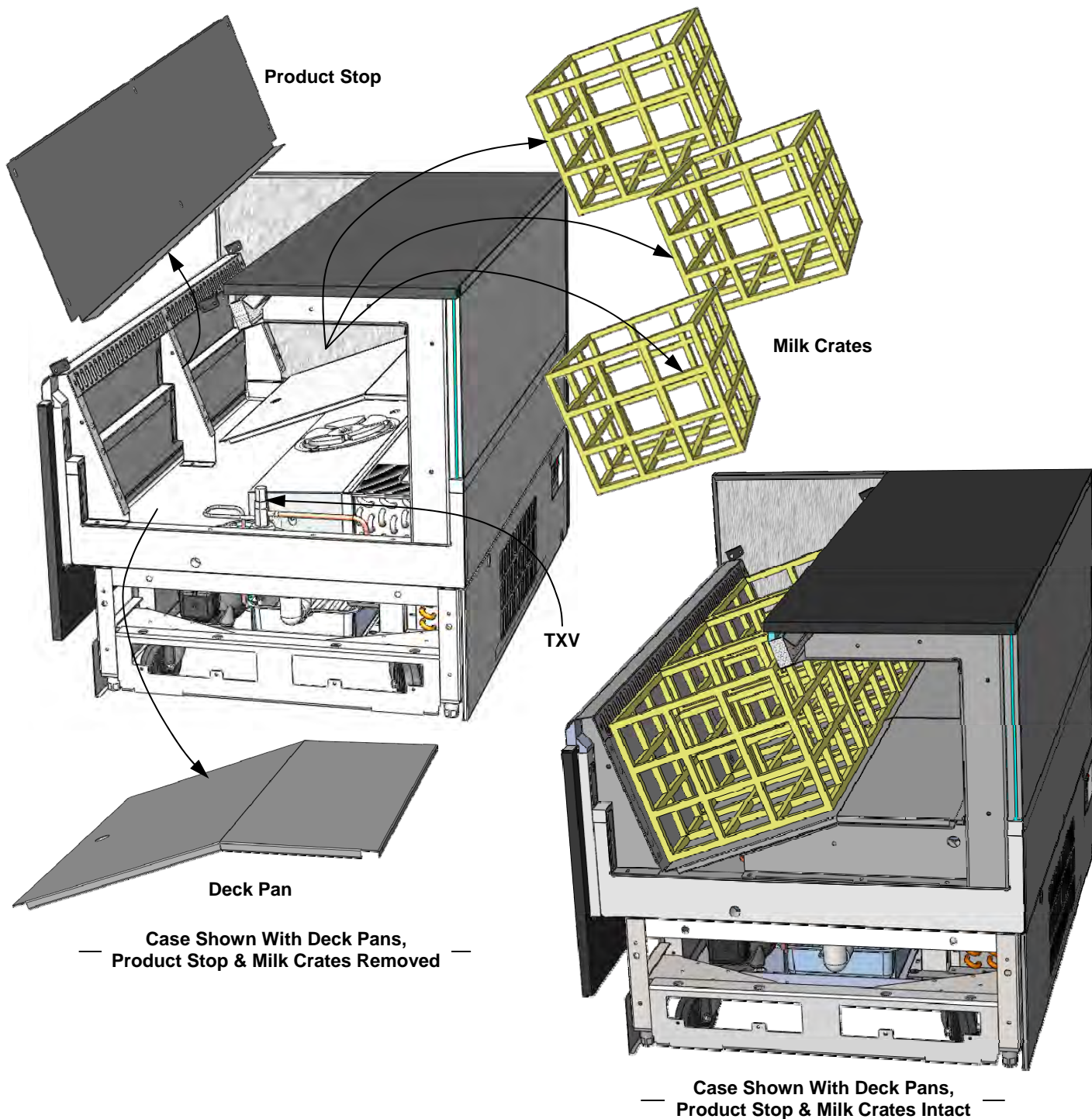

**1. Evaporator Fan Access**

- Remove lower decking.
- Lift decks straight up and out to avoid scratching insides of case while removing decks.

**2. Balancing Valve / Sweat Valve Access**

- Balancing valve and sweat valve becomes accessible upon removal of decking.

**3. Drain**

- Drain is located at front right side of as shown below.
- Access to drain may also be gained by removing evaporator fan shroud.

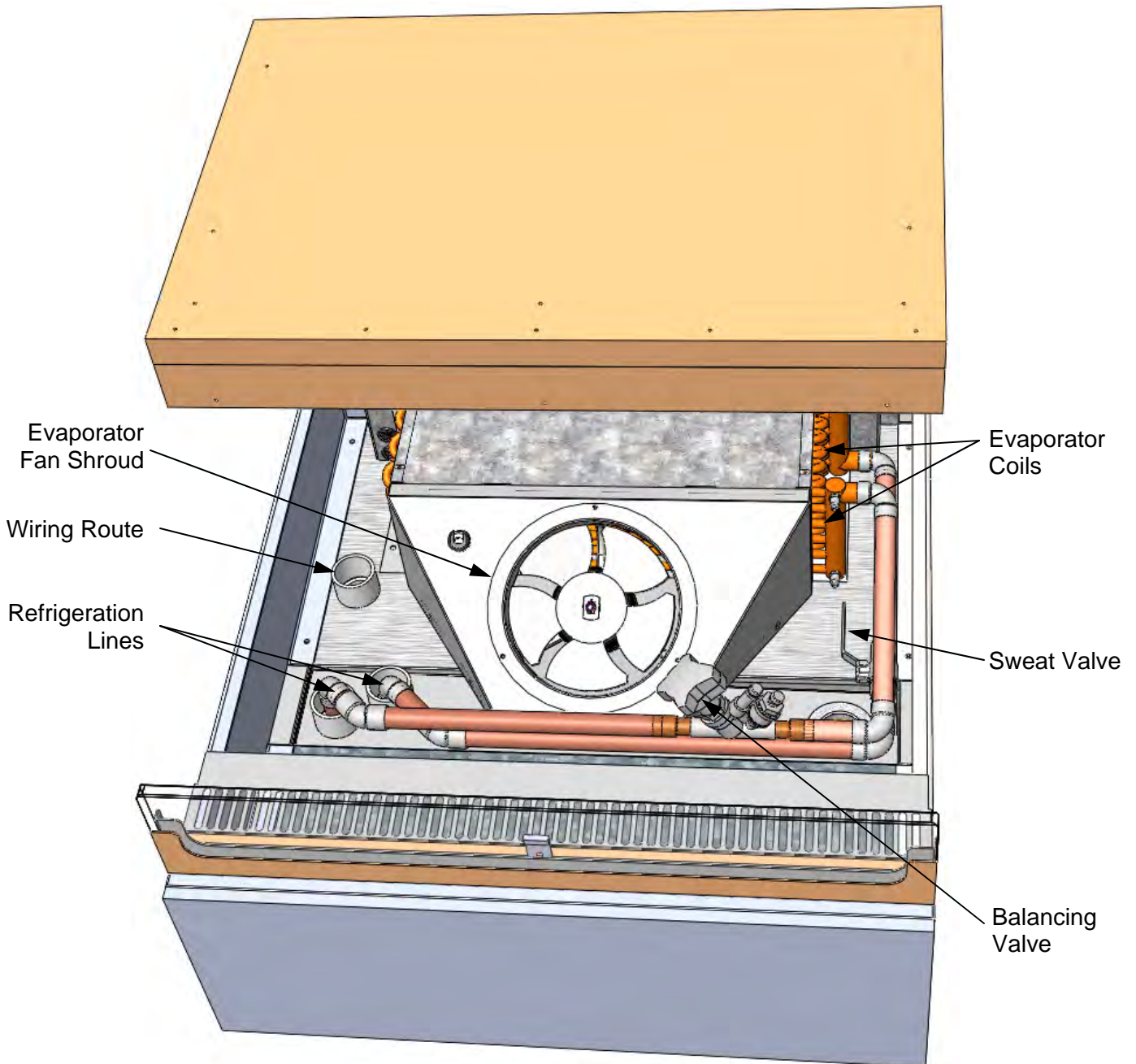

Above Illustration Shown With End Panel and Decking Removed For Illustrative Purposes

## REFRIGERATION - CONDENSATE PACKAGE ACCESS (SCREW REMOVAL REQUIRED)

### Refrigeration Fundamentals

#### **1. Condensate Package Access With Screw Removal Required**

- **Assembly or disassembly and servicing of condensate package is to be accomplished by a licensed refrigeration contractor.**
- Refer to maintenance fundamentals for access.
- Remove rear grille (by removing 4 screws) as shown in illustration at right and below.
- See next page for units with rear grilles requiring NO screw removal.

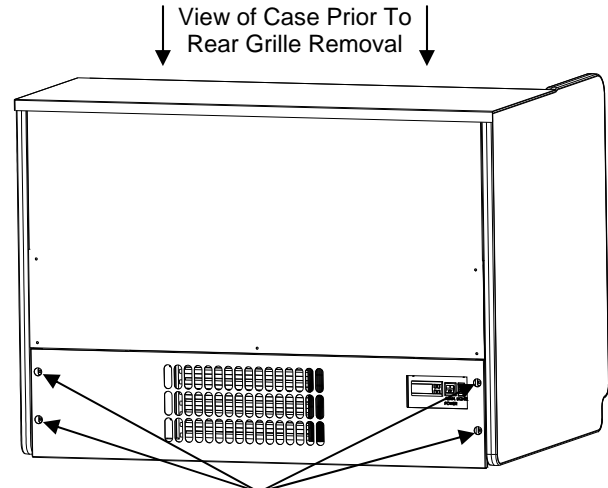

Screw Removal Required To Remove Rear Grille

**Note:** Illustrations Shown May Not Exactly Reflect Every Feature or Option of Your Particular Case.

View of Case Rear After Rear Grille Removal

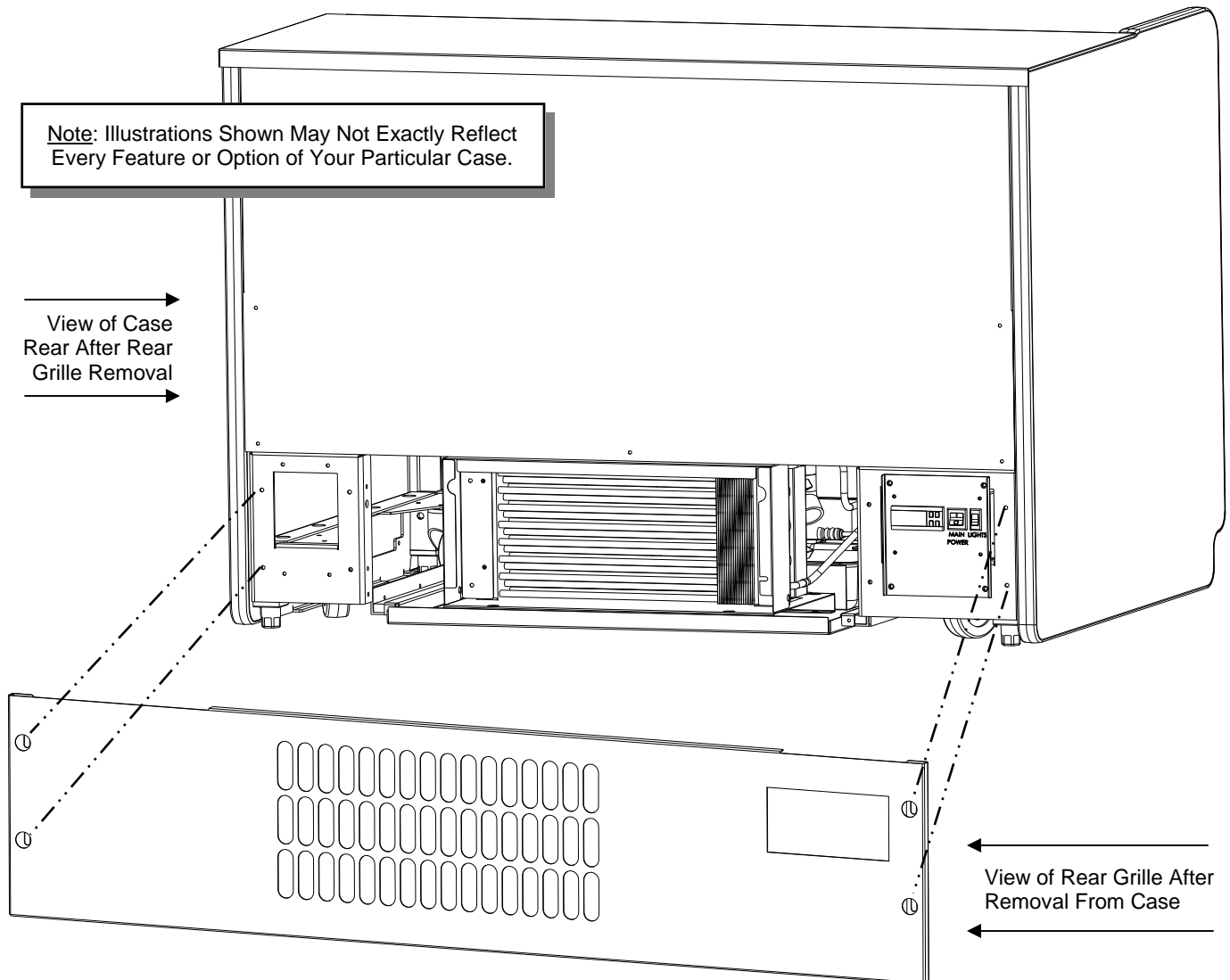

View of Rear Grille After Removal From Case

## REFRIGERATION - CONDENSATE PACKAGE ACCESS (NO SCREW REMOVAL REQUIRED)

### Refrigeration Fundamentals, Continued

#### 2. Condensate Package Access - No Screw Removal Required

- **Assembly or disassembly and servicing of condensate package is to be accomplished by a licensed refrigeration contractor.**
- Refer to maintenance fundamentals for access.
- Remove rear grille by grasping two (2) finger holes and pulling outward.

- Rear grille will then be free from rear panel magnets (one at each end).
- Slots of rear grille (one at each end) grille may then be lifted up and off rear panel hooks (one at each end).
- See previous page for rear grilles that require screw removal.

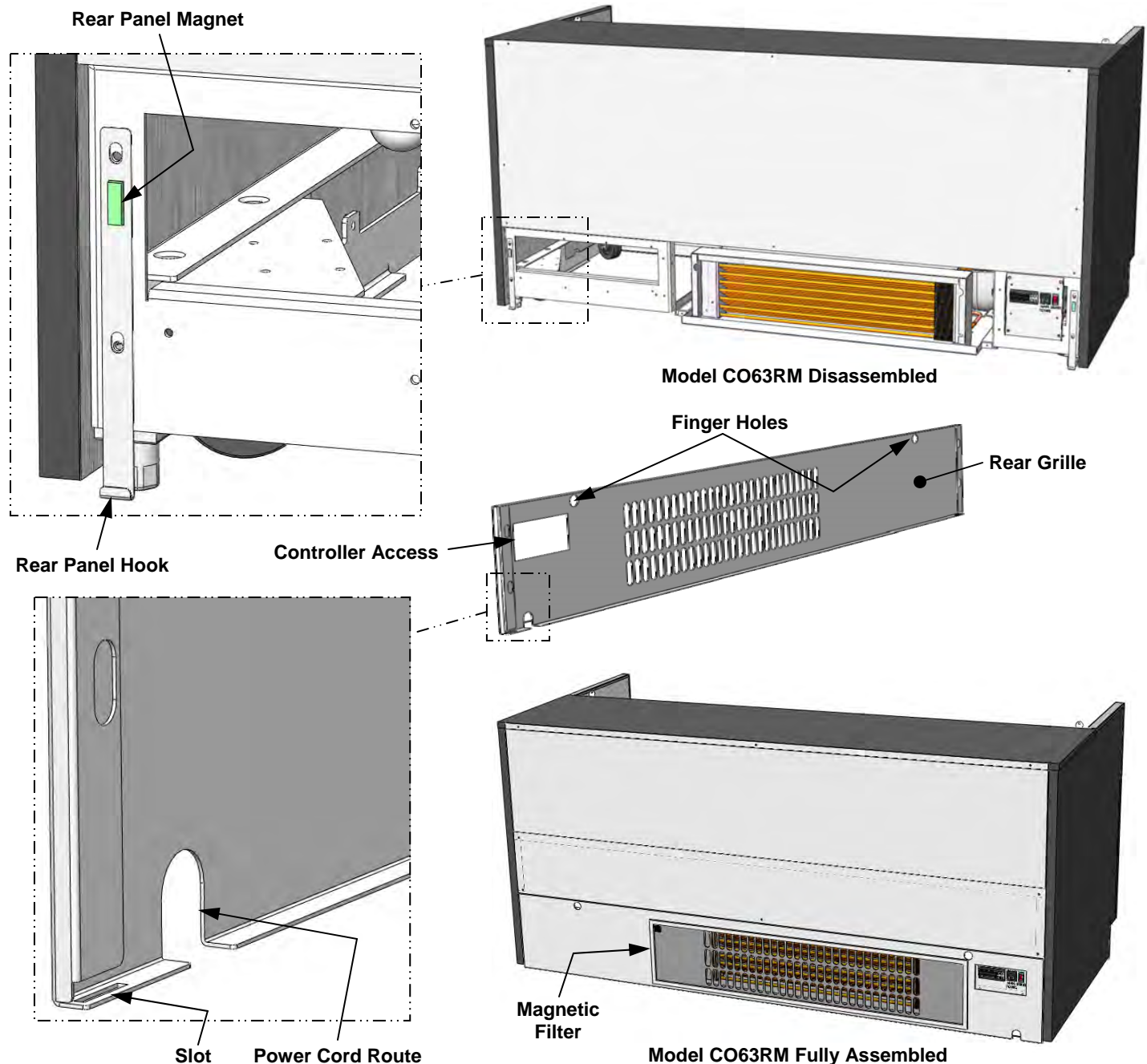

Refrigeration Fundamentals, Continued

**3. Condensate Package Illustrated Parts Breakdown**

- **Assembly or disassembly and servicing to be accomplished by licensed refrigeration contractor.**
- After rear grille has been removed, slide condensate package out slowly and carefully.
- After service, slide back under case. Return rear grille to case and attach with four (4) retaining screws.
- See previous page for screw removal illustration.

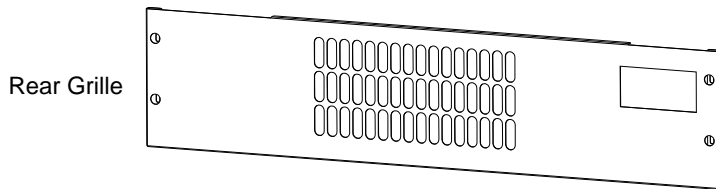
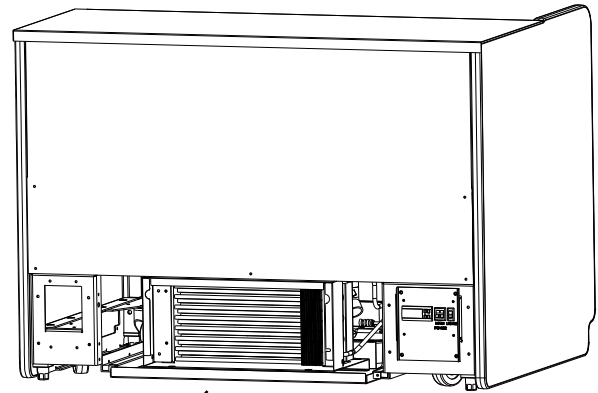

Condensate Package  
Shown Rotated For  
Illustrative Purposes

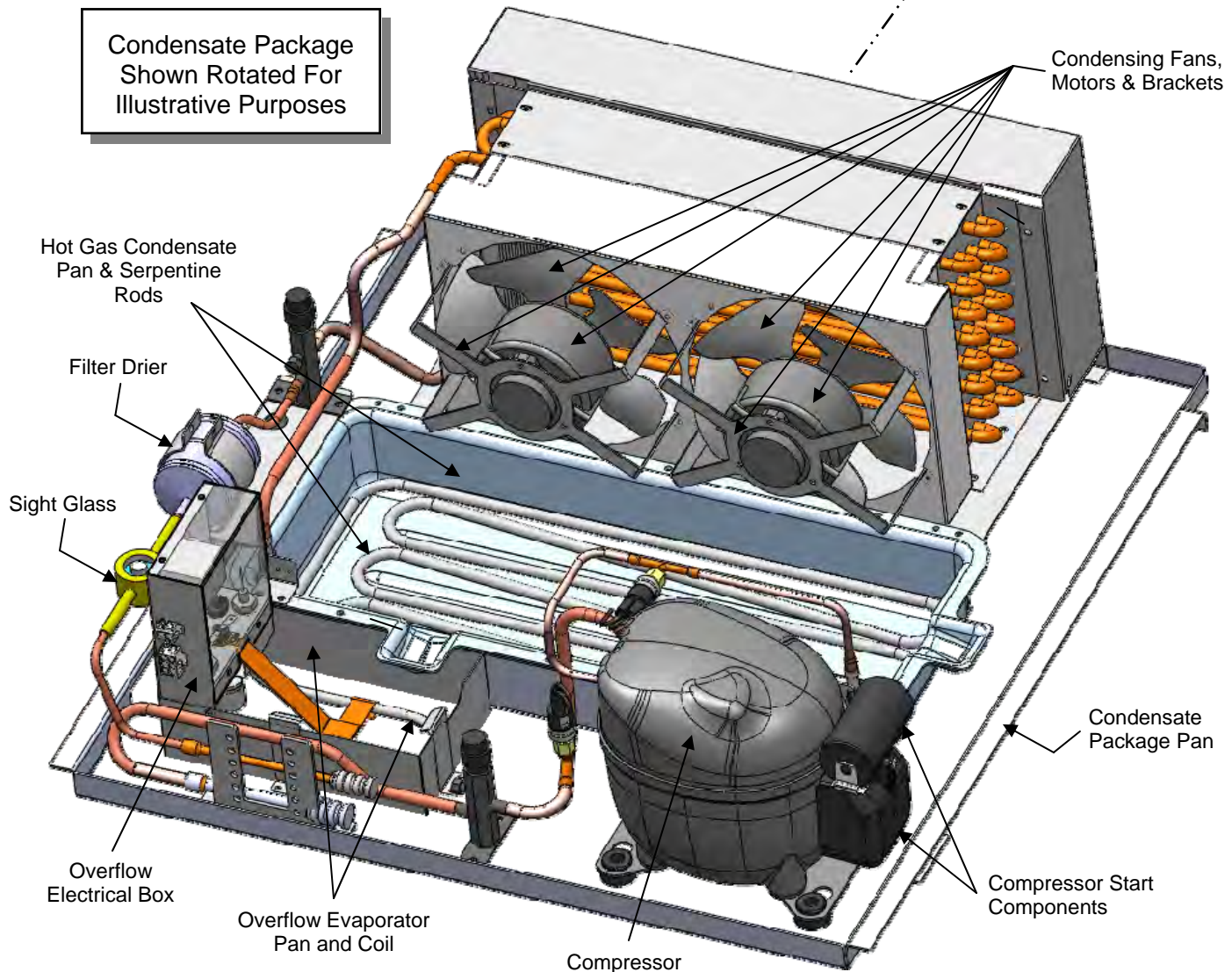

Refrigeration Fundamentals, Continued

**4. Condensate Package Illustrated Parts Breakdown**

- **Assembly or disassembly and servicing to be accomplished by licensed refrigeration contractor.**
- After rear grille has been removed, slide condensate package out slowly and carefully.
- After service, slide back under case. Return rear grille to case and attach with four (4) retaining screws.

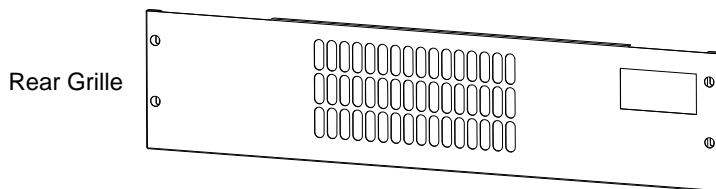
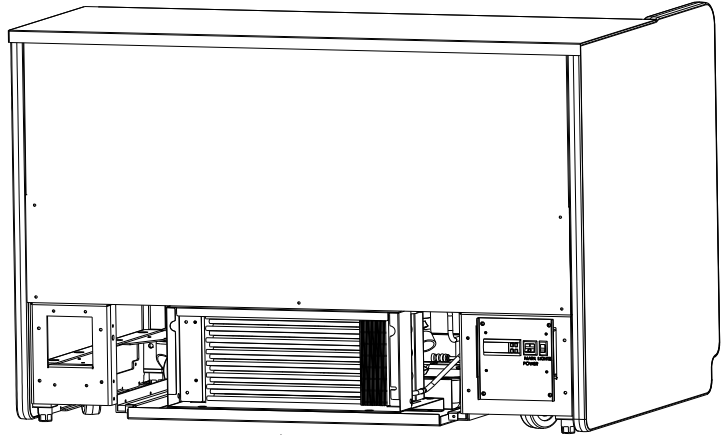

**Note:** Condensate Package Shown Rotated For Illustrative Purposes

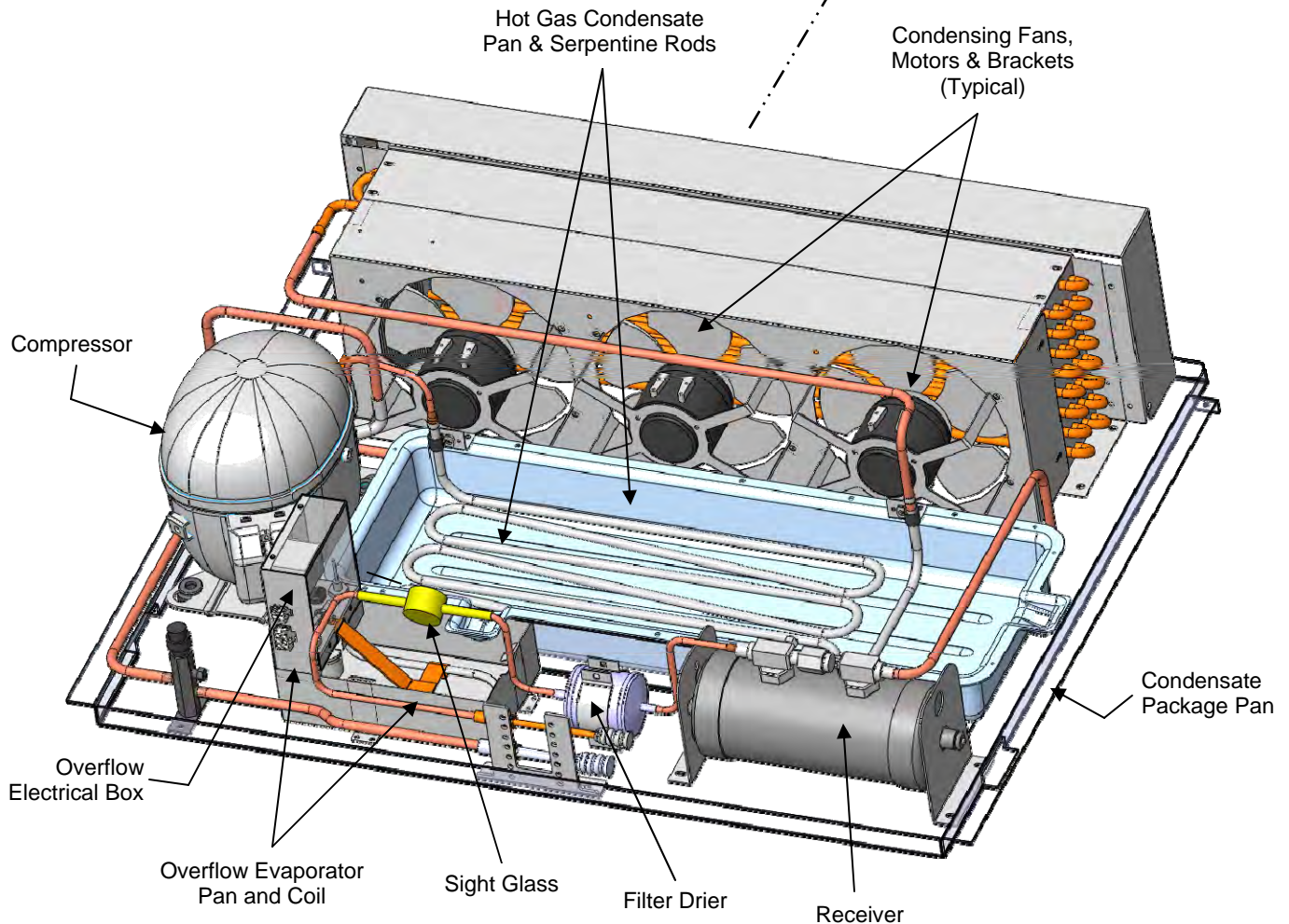

**GENERAL CLEANING (TO BE PERFORMED BY STORE PERSONNEL) - EXTERIOR**

**NOTE: INSTRUCTIONS ARE FOR CASE EXTERIOR ONLY (D=DAILY / W = WEEKLY / M = MONTHLY)**

FREQ.	INSTRUCTIONS
D	<b><u>Sides/Top/Front Panel:</u></b> Clean with household or commercial cleaner, soft cloth or paper towel.
D	<b><u>Acrylic Air Deflector:</u></b> Clean with a mild soap and water solution and a soft cloth.
D	<b><u>Glass Sneeze Guards:</u></b> Clean with household or commercial glass cleaner.
D	<b><u>Sanalite® Cutting Board (Model CO3434RG.5716, CO4836R.5716):</u></b> Sanalite® cutting boards require very little maintenance. Use a clean cloth to thoroughly wipe entire Sanalite® surface with hot water and soap solution on a regular basis. Rinse with a spray bottle of clean water. Pat dry with clean cloth or paper towel.
D	<b><u>Acrylic Bread Bins / Bread Display Supports:</u></b> Clean out bread crumbs with a paper towel or clean cloth. Wipe off any smudges or fingerprints with mild soap and warm water solution and soft cloth.
W	<b><u>Magnetic Condenser Coil Filter (Self-Contained Units Only):</u></b> <ul style="list-style-type: none"> <li>• This filter (accessible at case rear) helps prevent dust particles from entering condenser coil.</li> <li>• Clean magnetic condenser coil filter by following either of these steps:               <ol style="list-style-type: none"> <li>1. As magnetic condenser coil filter is dishwasher safe, remove from case (no screw removal required) and use a rag or soft-bristled brush to wipe off excess dust particles from filter. Run in normal dishwasher cycle. Remove from dishwasher. Dry with soft cloth or paper towel. Return to case.</li> <li>2. If NOT using dishwasher, remove magnetic condenser coil filter from case. Use a rag or soft-bristled brush to wipe off excess dust particles from filter. Submerge in warm, soapy water. Use soft-bristled brush to remove dust, dirt, grease and grime that may collect on filter. Rinse thoroughly. Dry with soft cloth or paper towel or allow to air dry. Replace.</li> </ol> </li> </ul>
W	<b><u>Model CO3434RG.5716 Salad Tissue Box Holder / Sandwich Wrap Holder:</u></b> <ul style="list-style-type: none"> <li>• Clean with a mild soap and water solution and a soft cloth. Dry with paper towel or cloth.</li> <li>• For more thorough cleaning, remove from case rear (by lifting up and off). Submerge in warm soapy water and use a nylon brush to remove hardened residue. Rinse thoroughly. Dry with paper towel or soft, clean cloth. Return to case.</li> </ul>
W	<b><u>Model CO3434RG.5716 Writing Instrument Cup:</u></b> <ul style="list-style-type: none"> <li>• Remove from case rear (by lifting up and away from unit). Submerge in warm soapy water and use a nylon brush to remove hardened residue. Rinse thoroughly. Dry with paper towel or soft, clean cloth. Return to case.</li> </ul>
W	<b><u>Model CO3434RG.5716 Sanitary Wipe Bucket:</u></b> <ul style="list-style-type: none"> <li>• Remove from case rear (by lifting up and away from unit).</li> <li>• Submerge in warm soapy water and use a nylon brush to remove hardened residue.</li> <li>• Rinse thoroughly. Dry with paper towel or soft, clean cloth. Return to case.</li> </ul>
M	<b><u>Night Air Curtain:</u></b> <ul style="list-style-type: none"> <li>• Grasp handle, slowly raise curtain and attach to top panel (as shown in <b><i>MAINTENANCE FUNDAMENTALS: NIGHT AIR CURTAIN OPERATING INSTRUCTIONS</i></b> section in this manual for illustrations.</li> <li>• After curtain is fully extended, wipe down with warm soapy water and soft cloth.</li> <li>• After curtain has been wiped down, use spray bottle with clean water to spray surface of curtain (to remove soap residue) and dry with paper towel or soft, clean cloth.</li> <li>• Return night air curtain to its retracted position slowly and carefully.</li> </ul>

**GENERAL CLEANING (TO BE PERFORMED BY STORE PERSONNEL) - INTERIOR**

**NOTE: INSTRUCTIONS ARE FOR CASE INTERIOR ONLY (D=DAILY / W = WEEKLY / M = MONTHLY)**

FREQ.	INSTRUCTIONS
D	<p><b><u>Decking, Rear Plenum</u></b>: Clean with a warm soap and water solution. For stubborn stains/residue, TURN MAIN POWER SWITCH OFF. Remove deck and clean with soap and water solution or submersed in hot, soapy water solution. Rinse thoroughly. Dry. Return to case. Turn main power switch back on.</p>
D	<p><b><u>Product Display Risers/Steps (Optional)</u></b>: Remove steps for cleaning purposes.</p> <ul style="list-style-type: none"> <li>• Light cleaning: Remove. Wipe with mild soap and water solution and soft cloth.</li> <li>• Severe cleaning: Remove and submerge in warm to hot water solution. Clean with soft cloth or non-metal brush.</li> </ul>
D	<p><b><u>Glass Surfaces</u></b>: Clean with household or commercial glass cleaner.</p>
W	<p><b><u>Air Return Grilles</u></b>:</p> <ul style="list-style-type: none"> <li>• Wipe off air return airflow grilles with moist cloth.</li> <li>• Return airflow grilles can be removed, submersed in warm, soapy waterfor more thorough cleaning. Rinse thoroughly before returning.</li> </ul>
M	<p><b><u>Condenser Coil</u></b>: Remove rear grille. Vacuum or brush grille condenser coil. Use metal or fiber brush to remove dust and dirt that can collect on condenser coils. Be careful not to damage the fins on the coil. See <b>REFRIGERATION FUNDAMENTALS: ACCESS / CONNECTIONS / SERVICING</b> section in this manual for instructions on rear grille removal.</p>

**GENERAL CLEANING (TO BE PERFORMED BY TRAINED SERVICE PROVIDERS ONLY)**

AREA TO CLEAN	FREQUENCY	INSTRUCTIONS
Case Interior	Monthly	<p><b><u>Evaporator Fan Shroud Area (Under Decking):</u></b> <i>Caution! Due to rotating fans in area, turn off case and disconnect plug from wall outlet before beginning fan shroud (and surrounding tub area) cleaning!</i> 1) Turn off power. 2) Remove deck from case. 3) Clean fan shroud area (and surrounding tub area) with moist cloth.</p>
	Quarterly	<p><b><u>Tub &amp; Drain:</u></b> <i>Caution! Due to rotating fans in area, turn off case and disconnect plug from wall outlet before beginning tub &amp; drain cleaning!</i> Vacuum tub under decks. Clean with soap and water solution. Wipe dry with clean cloth. Keep drain free of debris to prevent clogging.</p> <ul style="list-style-type: none"> <li>Note: Fan shroud must be removed to access drain at center of tub.</li> </ul>

**TROUBLESHOOTING (TO BE PERFORMED BY STORE PERSONNEL)**

CONDITION	TROUBLESHOOTING
<b>Water Is On The Floor</b>	Call service provider.
<b>Fan Emits Excessive Noise</b>	Call service provider.
<b>No Case Lights Are Working</b>	Check that light switch is in the <i>on</i> position.
	Check that ALL of the light cords and plugs are properly connected. See <b>LED LIGHT FIXTURES: REPAIR / REMOVAL / REPLACEMENT</b> section in this manual for specifics.
	Check circuit breaker box for tripped circuit.
	If case lights still do not come on, call service provider.
<b>Case Light Is Not Working</b>	<p>Check that ALL of the light cords and plugs are properly connected. This includes the following items:</p> <ul style="list-style-type: none"> <li>• Oval form of plug must connect to oval form of LED light.</li> <li>• See <b>MAINTENANCE FUNDAMENTALS - LED LIGHT FIXTURE / LOCATION / REPAIR / REPLACEMENT</b> section in this manual for more specifics including illustrations.</li> </ul>
	If case light still does not come on, call service provider.
<b>Case is Not Holding Proper Temperature</b>	If a large amount of warm product was added to the case, it will take time for the temperature to adjust. Product must be pre-chilled before placing in case.
	Check that the case is not in the sun or near a heat or air-conditioning vent. See <b>OVERVIEW / TYPE / COMPLIANCE / WARNINGS / PRECAUTIONS / WIRING / PLUGS</b> section in this manual for specifics.
	If case is located near front doors, temperature fluctuation can hinder unit's ability to maintain temperature. See <b>OVERVIEW / TYPE / COMPLIANCE / WARNINGS / PRECAUTIONS / WIRING / PLUGS</b> section in this manual for specifics.
	Check that filter and condenser coil has been cleaned. See <b>GENERAL CLEANING (TO BE PERFORMED BY STORE PERSONNEL)</b> section in this manual for specifics.
	Check air return grilles (area at front of decking) for obstructions. <b>DO NOT</b> set product on air grilles as this will prevent proper airflow!
	If case still is not holding proper temperature, call service provider.

**TROUBLESHOOTING (TO BE PERFORMED BY TRAINED SERVICE PROVIDERS ONLY)**

CONDITION	TROUBLESHOOTING
<b>Water Is On The Floor</b>	Check that the drain trap is free of debris.
	Check that the drain hose is correctly positioned over evaporator pan.
	Check store conditions. <ul style="list-style-type: none"> <li>• For Type 1 Conditions (most cases): ambient conditions are to be at 55% max. humidity / 75°F.</li> <li>• For Type 2 Conditions: ambient conditions are to be at 60% maximum humidity / 80°F.</li> </ul>
	Check that the hot gas condensate pan is properly connected and heating.
	Wicking material (optional) may be dirty or worn and need replacement (hot gas loop condensate system). <ul style="list-style-type: none"> <li>• Slide refrigeration system out from under unit.</li> <li>• After refrigeration system has been slid out from under unit, replace wicking material with new. If wicking material is not available, contact Structural Concepts®. See toll-free number at last page of this manual.</li> </ul>
<b>Fan Emits Excessive Noise</b>	Check that the case is aligned, level and plumb.
	Check evaporator fan for cleanliness.
	Unplug/power off fan motor. Check motor shaft for bearing wear.
	Check that fan motor is securely mounted in bracket.
	Verify that fan blades are securely mounted to fan motor.
	Check that nothing is preventing blade rotation.
	Check that the fan shroud is properly secured.
<b>Fan Is Not Working</b>	Check that the MAIN power switch is on.
	Check that fan motor is plugged in at the fan shroud.
	Check for foreign material obstructing fan performance.
	Check that fan blades freely rotate within fan shroud.
	Check that power is going to fan.
	Check that fan wiring is connected on terminal blocks.
<b>Digital Control Display Is Blank.</b>	Check that the MAIN power switch is on.
	Check the circuit breaker box for tripped circuits.
<b>System Not Operating</b>	Check that the utility power is on.
	Check that the MAIN power switch is on.
	Check the circuit breaker box for tripped circuits.

**TROUBLESHOOTING (TO BE PERFORMED BY TRAINED SERVICE PROVIDERS ONLY), CONTINUED**

CONDITION	TROUBLESHOOTING
<b>No Case Lights Are Working</b>	Follow previous page's <b>System Not Operating</b> instructions.
	Check voltage at LED driver. If voltage is entering but not exiting, LED driver may be faulty.
	Check connection at case rear (from field wiring box) for voltage.
<b>Case Light Is Not Working</b>	Follow previous page's <b>System Not Operating</b> instructions.
	If case light still do not come on, call <b>SCC Technical Service</b> phone number (listed on last page of this operating manual).
<b>Control Display Is Flashing</b>	See your case's thermostat label (near temperature controller) for your model's required settings.
<b>Case Is Not Holding Temperature</b>	If a large amount of warm product was added to the case, it will take time for the temperature to adjust. Unit needs product to be pre-chilled.
	Temperature changes during defrost mode but will return to normal. Fourth LED (on temperature controller) will indicate defrost cycle in progress.
	Check that case is not in sun or near a heat or air-conditioning vent.
	If case is located near front doors, temperature fluctuation can hinder unit's ability to maintain temperature.
	Check that condenser coil has been cleaned.
	Check air grilles for obstructions.
	Check sight glass for flashing and/or low charge.
	Check Set Point Temperature; it may be adjusted too high.
<b>Condensing Unit Is Not Operating</b>	Check that the power is turned on.
	Determine if temperature controller settings are properly set. <i>See your case's serial label for your model's specified settings. See <b>SERIAL LABEL LOCATION &amp; INFORMATION LISTED / TECH INFO &amp; SERVICE</b> section in manual for label location, etc.</i>

**TROUBLESHOOTING (BY TRAINED SERVICE PROVIDERS ONLY) - CONDENSING SYSTEM**

CONDITION	TROUBLESHOOTING
<b>Head Pressure Too High</b>	Check that the condensing coil is not dirty or covered.
	Check that condensing fans are working.
	Check that refrigerant is not overcharged.
	Perform sub-cooling check and verify that no contaminants are in system.
	Check that liquid line filter dryer is not plugged.
	Check that close-offs are intact (around condensing coil) and that air is not recirculate.
	Check that store ambient temperature isn't above maximum allowed. See <b>OVERVIEW / TYPE / COMPLIANCE / WARNINGS / PRECAUTIONS / WIRING / PLUGS</b> section in this manual.
<b>Head Pressure Too Low</b>	Check if sight glass is flashing or showing low charge.
	Check that suction pressure isn't too low.
	Check that compressor reed valves aren't bad. Look for high suction/low head pressure. Perform pump down.

**TROUBLESHOOTING (BY TRAINED SERVICE PROVIDERS ONLY) - EVAPORATOR SYSTEM**

CONDITION	TROUBLESHOOTING
<b>Low Suction Pressure</b>	Check if sight glass is flashing or showing low charge.
	Check that expansion valve (TXV) isn't restricted. Check element charge.
	Check that liquid line or filter isn't restricted. Check that refrigeration lines and/or hoses are not kinked on either high or low sides.
	Check that evaporator fan motors are working.
	Check superheat.
	Check that there is no air recirculation around evaporator coil.
	Check that evaporator coil is not iced up.
<b>High Suction Pressure</b>	Check for refrigerant overcharge.
	Check that compressor reed valves aren't bad. Look for high suction/low head pressure. Perform pump down.
	Check that the "cooling load" isn't high. Product must be pre-chilled before placing in refrigerated section of case.
	Check that case is at least <u>15-feet</u> from exterior doors, overhead HVAC vents or any air curtain disruption.
	Check that unit is not exposed to direct sunlight via windows or any other heat source (ovens, fryers, etc.).
	Check that superheat adjustment isn't low.
	Check TXV bulb installation <ul style="list-style-type: none"> <li>a. Poor thermal contact.</li> <li>b. Warm location.</li> </ul>

**PREVENTIVE MAINTENANCE (TO BE PERFORMED BY TRAINED SERVICE PROVIDERS ONLY)**

**WARNING! TURN OFF CASE BEFORE PERFORMING PREVENTIVE MAINTENANCE!**

PREVENTIVE MAINTENANCE	FREQUENCY	INSTRUCTIONS
Case Exterior	Quarterly	<p><b><u>Condensing Coil:</u></b></p> <ul style="list-style-type: none"> <li>• Remove rear grille (by lifting up and off).</li> <li>• Use air pressure or industrial strength vacuum; clean dust and dirt that may collect on the Condenser Coil.</li> <li>• <b>Caution! Coil fins are sharp. Handle with care!</b></li> <li>• Replace rear grille to case.</li> </ul>
	Quarterly	<p><b><u>Refrigeration Package/Compressor Area:</u></b> <i>Caution! Be certain to disconnect power from case before cleaning Refrigeration Package!</i></p> <ul style="list-style-type: none"> <li>• <i>Warning! Condensate Pan Is HOT! Disconnect power from case and allow to cool before cleaning evaporator pan!</i></li> <li>• Slide/Roll compressor package out from under case.</li> <li>• See <b>REFRIGERATION FUNDAMENTALS</b> section for in-depth instructions on accessing the evaporator pan.</li> <li>• Use a scrub-brush and a de-scaling solution such as CLR® (to prevent corrosion, lime and rust). Follow instructions as to proper dilution, safety precautions and scrubbing method.</li> <li>• After thoroughly cleaning pan with scrub-brush and solution, rinse thoroughly with clean water (in spray bottle) and wipe dry with sponge or paper towel.</li> <li>• Use moist cloth to wipe off dust &amp; debris that collects on various parts (fans, sight glass, overflow pan, etc.).</li> <li>• Slide refrigeration assembly back under case.</li> <li>• Replace front panel and lower grille via hooks (no screws required).</li> </ul>
	Quarterly	<p><b><u>Under Case Cleaning:</u></b> Once refrigeration package is clear of unit, vacuum under case to remove all dust and dirt that may collect under case.</p>
Case Interior	Quarterly	<p><b><u>Tub, Coil, Drain, Fans, Brackets:</u></b></p> <ul style="list-style-type: none"> <li>• Remove decking.</li> <li>• Use vacuum to clean entire area.</li> <li>• After vacuuming, clean area with warm water, clean cloth, and mild soap solution.</li> <li>• Remove any debris that may clog drain.</li> </ul>
	Quarterly	<p><b><u>Honeycomb:</u></b> Check honeycomb air diffuser to determine whether it is dirty. If dirty, remove from case. See <b>PREVENTIVE MAINTENANCE: HONEYCOMB AIR DIFFUSERS (TRAINED SERVICE PROVIDERS ONLY)</b> section of this manual (next page) for cleaning specifics.</p>

## PREVENTIVE MAINTENANCE - HONEYCOMB (BY TRAINED SERVICE PROVIDERS ONLY)

### **1. Honeycomb Air Diffuser Removal**

See **PREVENTIVE MAINTENANCE (TO BE PERFORMED BY TRAINED SERVICE PROVIDER)** section in this manual for cleaning frequency.

A. Wedge a non-metallic device of suitable strength (such as a ballpoint pen) between the honeycomb and the end panel.

**Caution!** Use care not to dislodge the heating wire (that prevents condensation on the lamp assembly).

B. Apply pressure to collapse the honeycomb to allow it to be pulled out of honeycomb retainer.

C. Carefully pry downward and away from the honeycomb retainer.

Clean honeycomb with warm water and soap solution. Submerge if necessary. Use brush to dislodge stubborn or sticky residue. Dry by using vacuum's blow mode (vs. suction mode).

### **2. Honeycomb Air Diffuser Installation**

D. Squeeze honeycomb to allow it to fit into the honeycomb retainer.

E. Carefully slide honeycomb into place.

F. Adjust honeycomb so that it fits flat against retainer. It must not be wavy or out of position.

**Note:** For honeycomb air diffusers in other locations, these same general instructions apply.

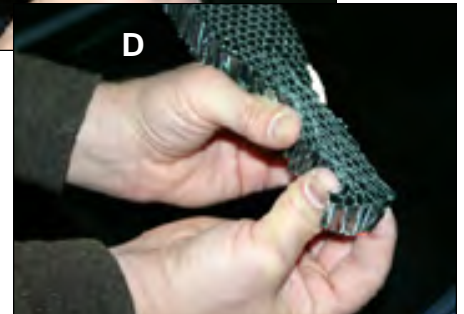

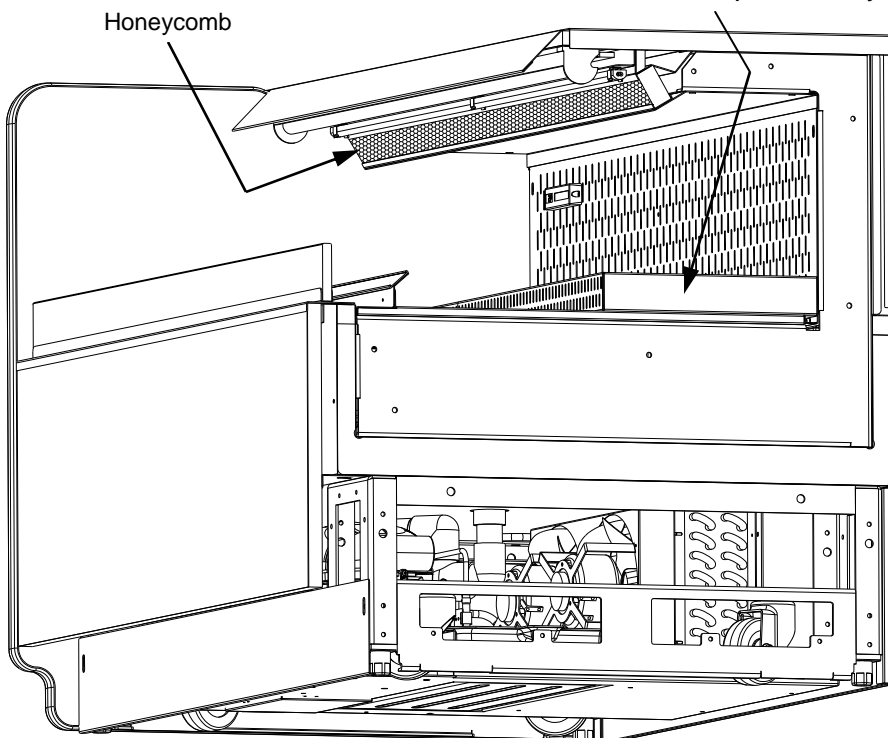

Optional Product Step (Not on All Cases) Shown For Illustrative Purposes Only



**Serial Label Location & Information Listed / Technical Information & Service**

- Serial labels are located near the electrical access on your case.
- Serial labels contain electrical, temperature & refrigeration information, as well as regulatory standards to which the case conforms.
- For additional technical information and service, see the *TECHNICAL SERVICE* page in this manual for instructions on contacting Structural Concepts' Technical Service Department.
- See image below for sample serial label.

 <p>888 E. Porter Rd · Muskegon, MI 49441</p>		<p><b>ENCORE<sup>®</sup></b> MODEL HV74RSS SCROLL SERIES SERIAL NO.</p>	
<p>FOR PARTS AND SERVICE CALL 1-800-433-9489</p>		<p><b>SAMPLE ONLY</b></p>	
 <p>3048256</p>		<p>ELECTRICAL RATING</p>	120/1/60 24A
<p>CONFORMS TO UL STD 471</p>		REFRIGERANT	R404A AMOUNT ?? OZ
<p>CONFORMS TO NSF STD 7</p>		DESIGN PRESSURE	HIGH 450 LOW 200
<p>CERTIFIED TO CAN/CSA STD C22.2 NO 120</p>		MINIMUM CIRCUIT	30A
		MAXIMUM OVERCURRENT	30A
<p><b>SAMPLE ONLY</b></p>			
Super Heat Temp	8-10°F	<p><b>SAMPLE ONLY</b></p>	
BTUH Requirements	9,738 BTUH @ 20° F SST		
Defrost	6 defrosts per day, 45° F termination, 45 min. failsafe		

----- Sample Serial Label For Refrigerated Case -----

# CAREL

## ir33 platform

Integrated Electronic  
Microprocessor Controller



### Programming The Instrument

#### To Modify The Setpoint

**Set** Press and hold the "SET" key for at least 1 second.

**▲/aux** **def/▼** 2. Use arrow keys ▲ ▼ on temperature controller to increase (or decrease) the setpoint.

**Set** 3. Quickly press and release the "SET" key again.

#### To Modify Defrost, Differential, Other Parameters

**Prg/mute** **Set** 1. Press & hold "Prg" & "SET" keys together for five (5) seconds; display will flash "0", representing password prompt.

**Set** 2. Confirm by pressing "SET" key.

**▲/aux** **def/▼** 3. Press ▲ or ▼ to reach the category to be modified.

**Set** 4. Press "SET" to modify this selected parameter.

**▲/aux** **def/▼** 5. Increase or decrease the value using the ▲ or ▼ button respectively.

**Set** 6. Press the "SET" key to temporarily save the new value and return to the display of the parameter.

**Prg/mute** 7. Press & hold the "Prg" key for at least 5 seconds to save changes. This action will also mute the audible alarm (buzzer) & deactivate the alarm relay.

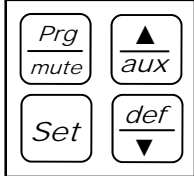

#### How To Change Reading From Fahrenheit (°F) To Celsius (°C)

**Prg/mute** **Set** 1. Press and hold "Prg" and "SET" keys together for at least 5 seconds; display will show "0" (password prompt).

**Set** 2. Confirm by pressing "SET" key.

**▲/aux** **def/▼** 3. Press ▲ or ▼ until reaching the parameter "/ 5".

**Set** 4. Press "SET" to modify this selected parameter.

**▲/aux** **def/▼** 5. Press ▲ or ▼ to change value to desired setting: "0" for Celsius (°C) or "1" for Fahrenheit (°F).

**Set** 6. Press "SET" key to temporarily save the new value and return to the display of the parameter.

**Prg/mute** 7. Press & hold "Prg" key for at least 5 seconds to save changes. **Note! All values will automatically convert to new scale. No conversion is required.**

#### Warning! Save Your Parameter Settings!

1. To store the new parameter values, PRESS and HOLD the "Prg" key for at least 5 seconds.
2. All modifications made to parameters will be lost if you do NOT press a button within 60 seconds. Should this "timeout" occur, normal operational settings (prior to modifications being made) will resume.
3. If the instrument is switched off before pressing the "Prg" key, all modifications to parameters will be lost.

**def/▼** **To Activate Manual Defrost**  
Press and hold "def" key for at least 5 seconds.

**▲/aux** **To Activate / Deactivate Auxiliary Output**  
Press and hold the "aux" key for 1 second.

**Prg/mute** **▲/aux** **To Reset Any Alarms With Manual Reset**  
Press and hold the "Prg" and "aux" key for at least 1 second.

# CAREL

**ir33 platform**  
**Integrated Electronic  
 Microprocessor Controller**



## User Interface - Display

ICON	FUNCTION	DESCRIPTION	Normal operation			Start up
			ON	OFF	BLINK	
	COMPRESSOR	ON when the compressor starts. Flashes when the activation of the compressor is delayed by safety times.	Compressor on	Compressor off	awaiting activation	
	FAN	ON when the fan starts. Flashes when the activation of the fan is prevented due to external disabling or procedures in progress.	Fan on	Fan off	awaiting activation	
	DEFROST	ON when the defrost is activated. Flashes when the activation of the defrost is prevented due to external disabling or procedures in progress.	Defrost in progress	Defrost not in progress	awaiting activation	
	AUX	Flashes if the anti-sweat heater function is active, ON when the auxiliary output (1 and/or 2) selected as AUX (or LIGHT in firmware version 3.6) is activated.	AUX auxiliary output active (version 3.6 light auxiliary output active)	AUX auxiliary output not active	Anti-sweat heater function active	
	ALARM	ON following pre-activation of the delayed external digital input alarm. Flashes in the event of alarms during normal operation (e.g. high/low temperature) or in the event of alarms from an immediate or delayed external digital input.	Delayed external alarm (before the time 'A7' elapses)	No alarm present	Alarms in norm. operation (e.g. High/low temperature) or immediate or delayed alarm from external digital input	
	CLOCK	ON if at least one timed defrost has been set. At start-up, comes ON for a few seconds to indicate that the Real Time Clock is fitted.	If at least 1 timed defrost event has been set	No timed defrost event set	Alarm clock	ON if real-time clock present
	LIGHT	Flashes if the anti-sweat heater function is active, ON when the auxiliary output (1 and/or 2) selected as LIGHT is activated (in firmware version 3.6 it does not flash in anti-sweat heater mode and comes on when the dead band output is active).	Light auxiliary output on (version 3.6 dead band auxiliary output active)	Light auxiliary output off	Anti-sweat heater function active (version 3.6 does not flash in anti-sweat heater mode)	
	SERVICE	Flashes in the event of malfunctions, for example E2PROM errors or probe faults.		No malfunction	Malfunction (e.g. E2PROM error or probe fault). Contact service	
	CONTINUOUS CYCLE	ON when the CONTINUOUS CYCLE function is activated. Flashes if the activation of the function is prevented due to external disabling or procedures in progress (E.g.: minimum compressor OFF time).	CONTINUOUS CYCLE operation activated	CONTINUOUS CYCLE function not activated	CONTINUOUS CYCLE operation requested	

## Summary Table of Alarm and Signals: Display, Buzzer and Relay

Code	Icon on the display	Alarm relay	Buzzer	Reset	Description
rE	flashing	on	on	automatic	virtual control probe fault
E0	flashing	off	off	automatic	room probe S1 fault
E1	flashing	off	off	automatic	defrost probe S2 fault
E2	flashing	off	off	automatic	probe S3 fault
E3	flashing	off	off	automatic	probe S4 fault
E4	flashing	off	off	automatic	probe S5 fault
'	No	off	off	automatic	probe not enabled
LO	flashing	on	on	automatic	low temperature alarm
HI	flashing	on	on	automatic	high temperature alarm
AFr	flashing	on	on	manual	antifreeze alarm
IA	flashing	on	on	automatic	immediate alarm from external contact
dA	flashing	on	on	automatic	delayed alarm from external contact
dEF	on	off	off	automatic	defrost running
Ed1	No	off	off	automatic/manual	defrost on evaporator 1 ended by timeout
Ed2	No	off	off	automatic/manual	defrost on evaporator 2 ended by timeout
Pd	flashing	on	on	automatic/manual	maximum pump down time alarm
LP	flashing	on	on	automatic/manual	low pressure alarm
AtS	flashing	on	on	automatic/manual	autostart in pump down
cht	No	off	off	automatic/manual	high condenser temperature pre-alarm
CHT	flashing	on	on	manual	high condenser temperature alarm
dor	flashing	on	on	automatic	door open too long alarm
EE	flashing	off	off	automatic	E2prom error, unit parameters
EF	flashing	off	off	automatic	E2prom error, operating parameters
ccb	Signal				start continuous cycle request
ccE	Signal				end continuous cycle request
dFb	Signal				start defrost call
dFE	Signal				end defrost call
On	Signal				switch ON
off	Signal				switch OFF
rES	Signal				reset alarms w/manual reset / reset HACCP alarms / reset temp. monitoring

# CAREL

## ir33 platform

Integrated Electronic  
Microprocessor Controller



### Summary Table of Operating Parameters

CODE	PARAMETER	UOM*	TYPE	MINIMUM	MAXIMUM	DEFAULT
/5	Select Celsius (°C) or Fahrenheit (°F)	flag	C	0	1	For Case Specific Defaults See Serial Label Located Near Electrical Access On Your Case.  For Additional Technical Information Call Structural Concepts Technical Service Dept. at 1(800) 433.9489
/c1	Calibration of probe 1	°C/°F	C	-20	20	
/c2	Calibration of probe 2	°C/°F	C	-20	20	
St	Temperature set point	°C/°F	F	r2	r1	
rd	Control delta	°C/°F	F	20	0.1	
dl	Interval between defrosts	hours	F	0	250	
dt1	End defrost temperature, evaporator	°C/°F	F	-50	200	
dP1	Maximum defrost duration, evaporator	min	F	1	250	
d6	Display on hold during defrost	-	C	0	2	
dd	Dripping time after defrost	min	F	0	15	
d/1	Display of defrost probe 1	°C/°F	F	-	-	

\* Unit Of Measure

STRUCTURAL CONCEPTS CORPORATION TECHNICAL SERVICE  
PHONE NUMBER: 1.800.433.9490 or For Your Master Service Agent See  
WWW.STRUCTURALCONCEPTS.COM/Contact/Master\_Service\_Agents.asp

# LIMITED WARRANTY

All sales by Structural Concepts Corporation (SCC) are subject to the following limited warranty. "Goods" refers to the product or products being sold by SCC.

**Warranty Scope:** Warranty is for equipment sold in the United States, Canada, Mexico and Puerto Rico. Equipment sold elsewhere may carry modified warranty.

**Warranty; Remedies; Limitations.** The limit of liability of SCC toward the exchange cost of the original compressor motor (and/or any other components) is one year parts and labor. If any Goods are found to be of faulty material or workmanship within one year of the original F.O.B. unit shipment, SCC will, at its option (after inspection by an authorized representative), replace or pay the reasonable cost of replacement of the faulty Goods. If warranty claim is not made within this one year time period, SCC is not bound to warrant Goods. A motor-compressor (and/or any other components) replaced during the warranty shall not exceed manufacturer's current established wholesaler's exchange price. If replacement motor-compressor (and/or other components) is available via storage facility, parts truck, etc., SCC mandates that readily accessible replacement components be used toward repair of Goods; in such instances, SCC will replace such equipment (at its own expense) after confirmation of its use/placement on defective unit. SCC shall not be charged an additional fee, up-charge or expense for such replacement Goods. If SCC is unable to repair or replace the defective Goods, SCC shall issue a credit to the Purchaser for full or partial purchase price, as SCC shall determine. The replacement or payment in the manner described above shall be the sole and exclusive remedy to Purchaser for a breach of this warranty. If any Goods are defective or fail to conform to this warranty, SCC will furnish instructions for their disposition. No Goods shall be returned to SCC without its prior consent.

SCC's liability for any defect in the Goods shall not exceed the purchase price of the Goods. SCC SHALL HAVE NO LIABILITY TO PURCHASE FOR CONSEQUENTIAL DAMAGES OF ANY KIND WHATSOEVER, INCLUDING, BUT NOT LIMITED TO, PERSONAL INJURY, PROPERTY DAMAGE, LOST PROFITS, OR OTHER ECONOMIC INJURY DUE TO ANY DEFECT IN THE GOODS OR ANY BREACH OF SCC. SCC SHALL NOT BE LIABLE TO THE PURCHASER IN TORT FOR ANY NEGLIGENT DESIGN OR MANUFACTURE OF THE GOODS, OR FOR THE OMISSION OF ANY WARNING THEREFROM.

SCC shall have no obligation or liability under this warranty for claims arising from any other party's (including Purchaser's) negligence or misuse of the Goods or environmental conditions. This warranty does not apply to any claim or damage arising from or caused by improper storage, handling, installation, maintenance, or from fire, flood, accidents, structural defects, building settlement or movement, acts of God, or other causes beyond SCC's control.

Except as expressly stated herein, SCC makes no warranty, express, implied, statutory or otherwise as to any parts or goods not manufactured by SCC. SCC shall warrant such parts or Goods only (I) against such defects, (II) for such periods of time, and (III) with such remedies, as are expressly warranted by the manufacturer of such parts of Goods. Notwithstanding the foregoing, any warranty with respect to such parts of Goods and any remedies available as a result of a breach thereof shall be subject to all of the procedures, limitations, and exclusions set forth herein.

THE WARRANTIES HEREIN ARE IN LIEU OF ALL WARRANTIES, EXPRESS, IMPLIED, STATUTORY, OR OTHERWISE. IN PARTICULAR, SCC MAKES NO WARRANTY OF MERCHANTABILITY OR FITNESS FOR A PARTICULAR PURPOSE.

No representative, agent or dealer of SCC has authority to modify, expand, or extend this Warranty, to waive any of the limitations or exclusions, or to make any different or additional warranties with respect to Goods.

**Period of Limitations.** No claim, suit or other proceeding may be brought by Purchaser for any breach of the foregoing warranty or this Agreement by SCC or in any way arising out of this Agreement or relating to the Goods after one year from the date of the breach. In the interpretation of this limitation on action for a breach by SCC, it is expressly agreed that there are no warranties of future performance of the goods that would extend that period of limitation herein contained for bringing an action.

**Indemnifications.** Purchaser agrees to indemnify, hold harmless, and defend SCC if so requested, from any and all liabilities, as defined herein, suffered, or incurred by SCC as a result of, or in connection with, any act, omission, or use of the Goods by Purchaser, its employees or customers, or any breach of this Agreement by Purchaser. Liabilities shall include all costs, claims, damages, judgments, and expenses (including reasonable attorney fees and costs).

**Remedies of SCC.** SCC's rights and remedies shall be cumulative and may be exercised from time to time. In a proceeding or action relating to the breach of this Agreement by Purchaser, Purchaser shall reimburse SCC for reasonable costs and attorney's fees incurred by SCC. No waiver by SCC of any breach of Purchaser shall be effective unless in writing nor operate as a waiver of any other breach of the same term thereafter. SCC shall not lose any right because it has not exercised it in the past.

Applicable Law. This Agreement is made in Michigan and shall be governed by and interpreted according to Michigan law. Any lawsuit arising out of this Agreement or the Goods may be handled by a federal or state court whose district includes Muskegon County, Michigan, and Purchaser consents that such court shall have personal jurisdiction over Purchaser.

**Miscellaneous.** If any provision of this Agreement is found to be invalid or unenforceable under any law, the provision shall be ineffective to that extent and for the duration of the illegality, but the remaining provisions shall be unaffected. Purchaser shall not assign any of its rights nor delegate any of this obligations under this Agreement without prior written of SCC. This Agreement shall be binding upon and inure to the benefit of SCC and Purchaser and each of their legal representatives, successors and assigns.

SCC warrants its products to be free of defects in materials and workmanship under normal use and service for a period of one (1) year from the date of delivery.

This warranty is extended only to the original purchaser for use of the Goods. It does not cover normal wear parts such as plastic tongs, tong holders, tong cables, bag holders, or acrylic dividers.

**General Conditions.** All service labor and/or parts charges are subject to approval by SCC. Contact the Customer Service Department in writing or call 231-798-8888.

All claims must contain the following information: (1) model & serial code number of equipment; (2) the date and place of installation; (3) the name and address of the agency which performed the installation; (4) the date of the equipment failure; and (5) a complete description of the equipment failure and all circumstances relating to that failure.

Once the claim has been determined to be a true warranty claim by SCC's Customer Service Department, the following procedure will be taken: (1) replacement parts will be sent at no charge from SCC on a freight prepaid basis; (2) reimbursement for service labor will be paid if the following conditions have been met - (a) prior approval of service agency was awarded from the Customer Service Department; and (b) an itemized statement of all labor charges incurred is received by the Customer Service Department. The cost of the service labor reimbursement will be based on straight time rates and reasonable time for the repair of the defect.

If problems occur with any compressor, notify SCC's Customer Service Department immediately. Any attempt to repair or alter the unit without prior consent from the Customer Service Department will render any warranty claim null and void. This warranty and protection plan does not apply to any condensing unit or any part thereof which has been subject to accident, negligence, misuse, or abuse, or which has not been operated in accordance with the manufacturer's recommendations or if the serial number of the unit has been altered, defaced, or removed.

**One Year Limit of Liability.** After SCC's one-year parts and labor warranty on the original F.O.B. unit has expired, SCC is not liable for either the equipment or labor costs of repairing or replacing the motor compressor, nor any other components that were included in the original F.O.B. unit.