



# INSTALLATION & OPERATING MANUAL - SCC P/N 54110

**Note: See Next  
Page For All  
Models Covered  
By This Manual**



Model B32



Model B42C

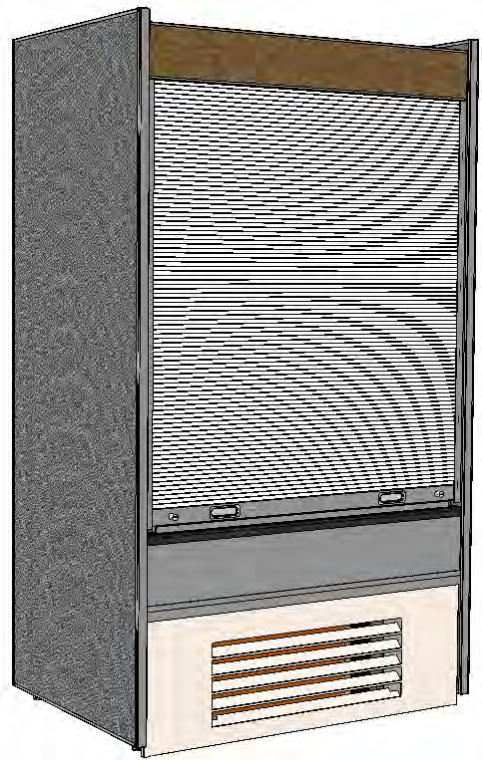

Model B4732  
(With Optional Roll-Down Security Cover)

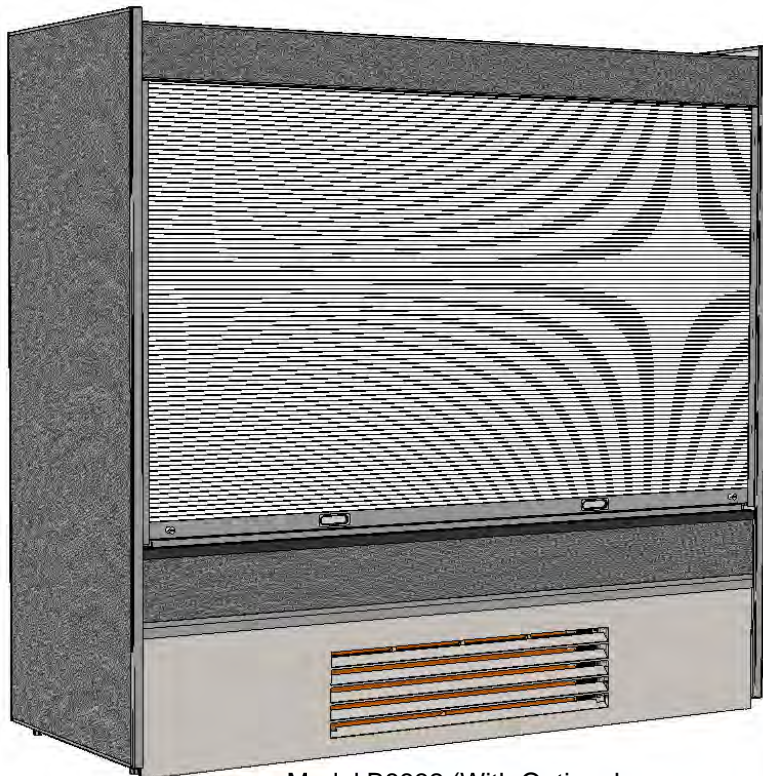

Model B8832 (With Optional  
Roll-Down Security Cover)

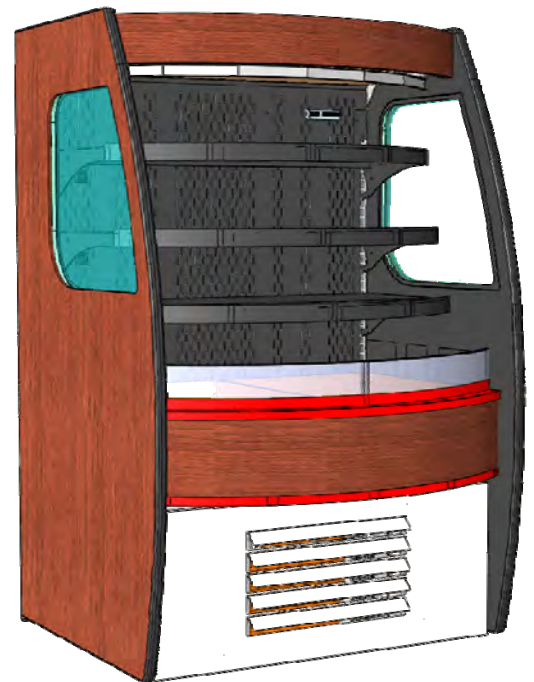

Model B43C



888 E. Porter Road • Muskegon, MI 49441 Phone: 231.798.8888 Fax: 231.798.4960 www.structuralconcepts.com

## TABLE OF CONTENTS / MODELS and DIMENSIONS

OVERVIEW / TYPE / COMPLIANCE / WARNINGS / PRECAUTIONS / WIRING / PLUGS .....	3-4
INSTALLATION: CASE REMOVAL / POSITIONING & ALIGNING CASE .....	5
INSTALLATION, CONT'D: OPTIONAL SECURITY COVER INSTRUCTIONS .....	6
FRONT GRILLE ACCESS / CHECK CONDENSER PAN / REFRIGERATION ASS'Y / TURN ON POWER .....	7
CHECK EVAPORATOR COIL FAN DISCHARGE / TXV [THERMOSTATIC EXPANSION VALVE] .....	8
HONEYCOMB AIR DIFFUSER ACCESS .....	9
HONEYCOMB AIR DIFFUSER REMOVAL / INSTALLATION .....	10
LIGHT FIXTURES [FLUORESCENTS & MINI-LEDs] .....	11-12
OPTIONAL ROLL-DOWN SECURITY COVER - MODEL B4732 ILLUSTRATED .....	13
WALL SPACING / REAR VENTING - MODEL B43C ONLY .....	14
CONDENSATE PAN ACCESS: STANDARD UNITS .....	15
CONDENSATE PAN ACCESS: REMOTE UNITS WITH CONDENSATE PANS ONLY .....	16
SELF-CONTAINED HOT GAS LOOP CONDENSATE PACKAGE LAYOUTS .....	17
LOAD LEVEL GUIDE / TEMPERATURE GUIDE [MODEL B42 SHOWN / APPLICABLE TO ALL OTHER MODELS IN MANUAL] .....	18
CLEANING SCHEDULE [TO BE PERFORMED BY STORE PERSONNEL] .....	19
PREVENTIVE MAINTENANCE [TO BE PERFORMED BY TRAINED SERVICE PROVIDERS ONLY]	20-22
TROUBLESHOOTING [TO BE PERFORMED BY TRAINED SERVICE PROVIDERS ONLY] .....	23-25
TROUBLESHOOTING [BY TRAINED SERVICE PROVIDERS ONLY] - CONDENSING SYSTEM .....	26
TROUBLESHOOTING [BY TRAINED SERVICE PROVIDERS ONLY] - EVAPORATOR SYSTEM .....	27
SERIAL LABEL LOCATION & INFORMATION LISTED / TECH INFO & SERVICE .....	28
CAREL® CONTROLLER OPERATING INSTRUCTION .....	29-31
TECHNICAL SERVICE CONTACT INFORMATION & WARRANTY INFORMATION .....	32

### **Models and Dimensions**

Model B32: 36"L* x 24"D x 81"H~	Model B5932: 59 1/2* x 32"D x 82 1/4"H~
Model B3632: 36 5/8"L* x 32"D x 82 1/4"H~	Model B62: 68"L* x 24"D x 81"H~
Model B42: 47"L* x 24"D x 81"H~	Model B7132: 71 5/8"L* x 32"D x 82 1/4"H~
Model B42C: 45"L* x 31 3/4"D x 81 7/8H~	Model B82: 90"L* x 24"D x 81"H~
Model B43C: 39 7/8"L* x 36 3/4D" x 61 1/4"H~	Model B8832: 88 1/4"L* x 32"D x 82 1/4"H~
Model B4732: 47 1/2* x 32"D x 82 1/4"H~	Model B9232: 92 5/8"L* x 32"D x 82 1/4"H~

*\*Includes End Panels / ~ With Adjustable Levelers Extended 1 5/8" Below Base Frame*

**OVERVIEW**

- These Structural Concepts merchandisers are designed to merchandise packaged products at 41 °F [5 °C] or less product temperatures.
- Product must be pre-chilled to 41 °F [5 °C] or less product temperatures prior to placing in merchandiser.
- Cases should be installed and operated according to this operating manual's instructions to ensure proper performance.
- Improper use will void warranty.

**CASE TYPE**

This unit is designed for the display of products in ambient store conditions where temperatures and humidity are maintained within a specific range.

- For Type 1 Conditions (most cases): ambient conditions are to be at 55% maximum humidity and maximum temperatures of 75 °F [24 °C].
- For Type 2 Conditions: ambient conditions are to be at 60% maximum humidity and maximum temperatures of 80 °F [27 °C].

- If unsure if unit is designed for Type 1 or 2, see tag next to serial label. See **SERIAL LABEL LOCATION & INFORMATION LISTED / TECH INFO & SERVICE** section in this manual for sample serial labels.

**COMPLIANCE**

- Performance issues when in violation of applicable NEC, federal, state and local electrical and plumbing codes are not covered by warranty.
- See below compliance guideline.

**WARNINGS**

- This sheet contains important warnings to prevent injury or death.
- Please read carefully!

**PRECAUTIONS, CORD/PLUG MAINTENANCE & WIRING DIAGRAM INFORMATION**

- See next page for **PRECAUTIONS, CORD/PLUG MAINTENANCE** and **WIRING DIAGRAM** information.



**COMPLIANCE**  
 This equipment **MUST** be installed in compliance with all applicable NEC, federal, state and local electrical and plumbing codes.



**WARNING**  
 Risk of electric shock. Disconnect power before servicing unit.  
**CAUTION!** More than one source of electrical supply is employed with units that have separate circuits.  
*Disconnect ALL ELECTRICAL SOURCES before servicing.*



**WARNING**  
 Hazardous moving parts. Do not operate unit with covers removed.  
 Fan blades may be exposed when deck panel is removed.  
 Disconnect power before removing deck panel.



**WARNING**  
 Condensate Pan is Hot!  
 Disconnect and allow to cool before cleaning or removing from case.

**PRECAUTIONS**

- This sheet contains important precautions to prevent damage to unit or merchandise.
- Please read carefully!
- See previous page for specifics on **OVERVIEW**, **TYPE**, **COMPLIANCE** and **WARNINGS**.

**WIRING DIAGRAM**

- Each case has its own wiring diagram folded and in its own packet.
- Wiring diagram placement may vary; it may be placed near ballast box, field wiring box, raceway cover, or other related location.



**CAUTION! LAMP REPLACEMENT GUIDELINES**  
 LED lamps reflect specific size, shape and overall design. Any replacements must meet factory specifications. Fluorescent lamps have been treated to resist breakage and must be replaced with similarly treated lamps.



**CAUTION! GFCI BREAKER USE REQUIREMENT**  
 If N.E.C. (National Electric Code) or your local code requires GFCI (Ground Fault Circuit Interrupter) protection, you **MUST** use a GFCI breaker in lieu of a GFCI receptacle.



**CAUTION! POWER CORD AND PLUG MAINTENANCE**  
 Risk of electric shock. If cord or plug becomes damaged, replace only with cord and plug of same type.

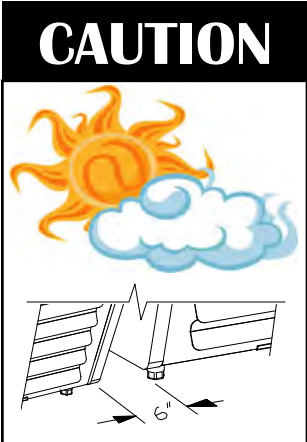

**CAUTION! ADVERSE CONDITIONS / SPACING ISSUES**

- Performance issues caused by adverse conditions are **NOT** warranted.
- End panels must be tightly joined or kept at least 6-inches away from any structure to prevent condensation.
- Unit must be kept at least 15-feet from exterior doors, overhead HVAC vents or any air curtain disruption to maintain proper temperatures.
- Unit must not be exposed to direct sunlight or any heat source (ovens, fryers, etc.).
- Tile floors, low ceilings or small rooms increase noise level. Whisper Cool compressor blankets or remote units resolve noise level issues.

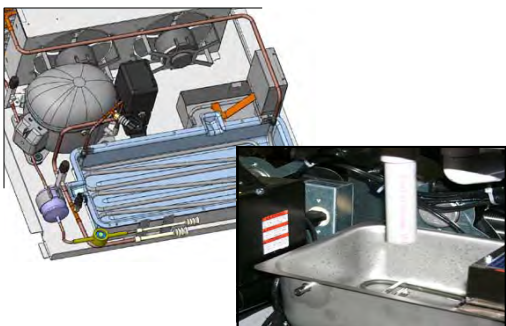

**CAUTION! CHECK CONDENSATE PAN POSITION & PLUG**  
 Water on flooring can cause extensive damage!  
 Before powering up unit, check and confirm that:

- Condensate pan is **DIRECTLY UNDER** condensate drain.
- Condensate pan plug is securely plugged into receptacle.
- Overflow pan has plug connected to its box. Units with optional Clean Sweep™ **MUST HAVE** two plugs connected.

## INSTALLATION: CASE REMOVAL / POSITIONING & ALIGNING CASE

### 1. Remove Case From Skid (Levelers)

- Remove shipping brace that may be securing case to skid.
- Support case to prevent tipping.
- *Caution! Levelers can be damaged if case hits floor with heavy force!*
- Carefully slide unit to rear of skid and tip backward off skid.
- Illustration may not reflect every feature or option of your particular case.

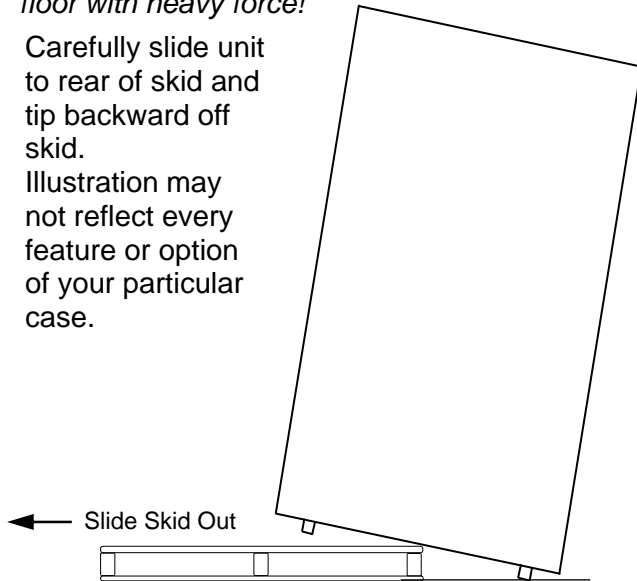

Case can be repositioned with pallet truck when front lower panel is removed. Blocking may be necessary to obtain adequate height.

### 2. Remove Case From Skid (Casters)

- Remove shipping brackets that may be securing casters to skid
  - Place ramp up against skid (to allow case to smoothly slide off from skid).
  - Maintain support of case at all times or center of gravity may cause case to fall.
  - Unlock Casters. Roll unit to rear of skid.
- Roll down ramp and off from skid.

*Note: Illustrations shown reflect a general outline of sample cases and do not reflect features or options of your particular model.*

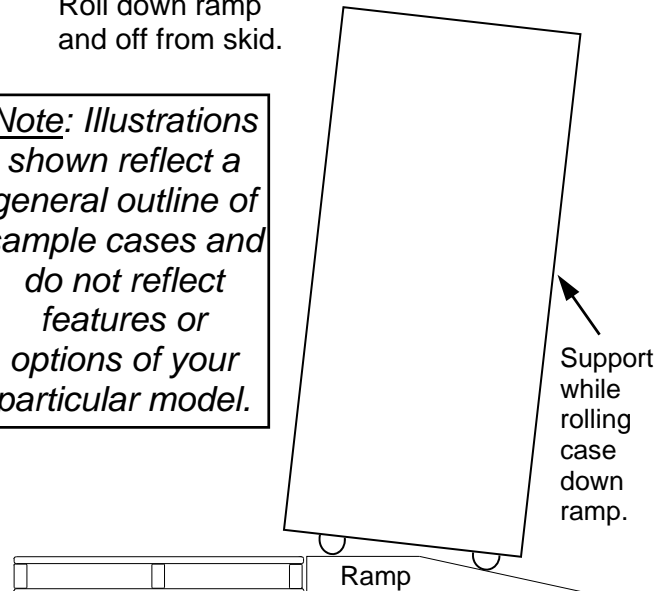

### 3. Position & Align Case Alongside Other Cases

- Before adjusting levelers, make certain that the case is in proper position and, if required, aligned with adjoining case(s).
- This may require the repositioning of the case you are installing or the already positioned case(s).

### 4. Adjust Levelers

- After case is in proper position, adjust case so it is level and plumb (see illustration at right).
- You may need to remove front and/or rear Toe-Kick to access levelers.
- Use adjustable wrench to adjust leveler.
- Depending upon case weight it may be necessary to use a Pry Bar to accomplish this task.
- Do not use Pry Bar on Toe-Kick as it may buckle.
- Do not use Pry Bar on End Panel as it may chip.
- Use Pry Bar **ONLY** on Base Frame to avoid damaging case.
- See illustration and photos at right.

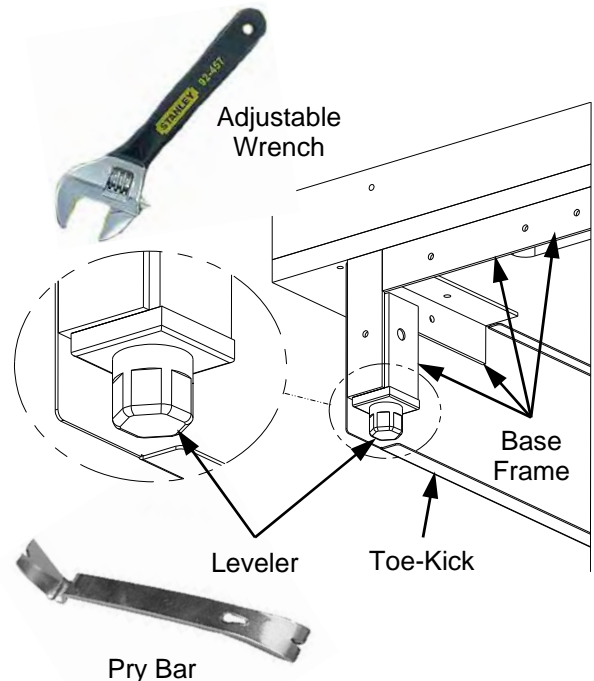

**5. Optional Security Cover Instructions**

**Caution! Security Cover MUST Be Placed On OUTSIDE of Acrylic Air Deflector and INSIDE Lower Security Bracket To Fit Properly.**

> Steps A, B and C correspond to this sheet's illustrations A, B and C. Follow these step-by-step instructions for proper security cover placement.

- A. Firmly hold security cover handles, and place the bottom of the security cover on the OUTSIDE of the acrylic air deflector and INSIDE of lower security bracket.
- B. Lean upper edge of security cover against upper bracket retainer (shown with hidden lines in illustration "B" on this sheet).

- C. Check that the lock properly rotates its locking mechanism into support angle slot (at upper area).
- > When removing security cover from case, store in safe location away from foot traffic.
- > Manufacturing note: if your case DOES NOT HAVE the hardware shown on this sheet for proper placement of security cover, contact Structural Concepts Corporation Technical Service. Toll-free number is listed on the last page of this document.

**Note:** Illustrations Shown May Not Exactly Reflect Every Feature or Option of Your Particular Case.

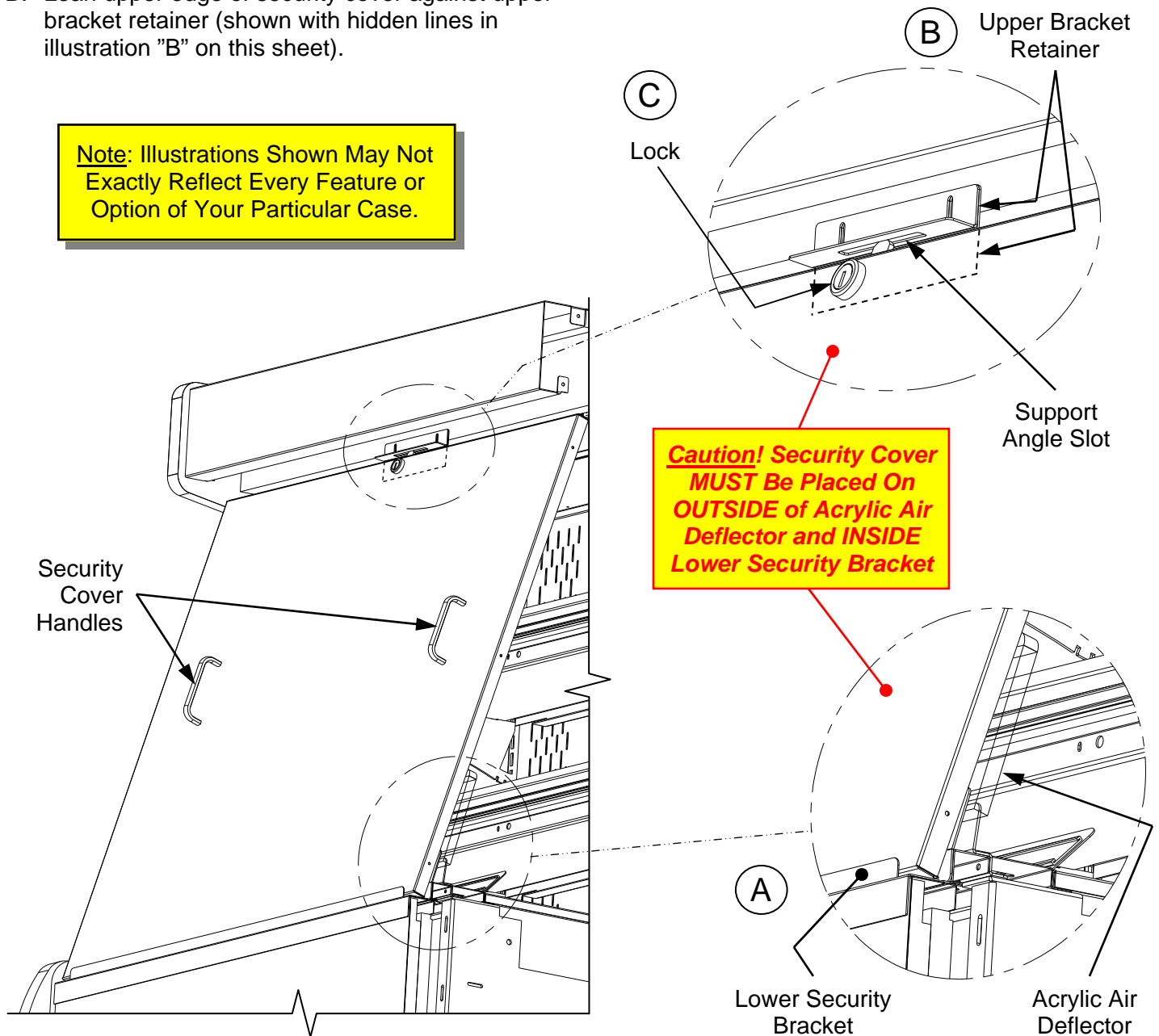

**1. Front Grille**

- Front grille can be accessed from case by removing two (2) screws holding grille in place. See illustrations at top-right.
- Remove front grille from front of case.
- Front grille may be reattached in same manner.

**2. Check That Condensate Pan is Properly Connected To Outlet**

- **Caution! Condensate pan can come unplugged from its electrical outlet during shipment!**
- If case runs without proper connection, water will overflow condensate pan and drain onto floor causing damage!
- Before turning case on, check that power cord from condensate pan is properly plugged in.
- See TROUBLESHOOTING section in operating manual for additional information.

**3. Sliding Refrigeration Assembly Out From Underside Of Case**

- At shipment, removal of compressor pan shipment screws may be necessary to access refrigeration ass'y.
- Refrigeration assembly base rests on plastic glides.
- Slide refrigeration assembly out from under case.

**4. Turning On Power To Case**

- Plug in power cord.
- Main power switch may be turned on by reaching through front grille; however, removal of front grille will allow unhindered access.
- Main power switch is located on main ballast box, below controller. See illustration at right.

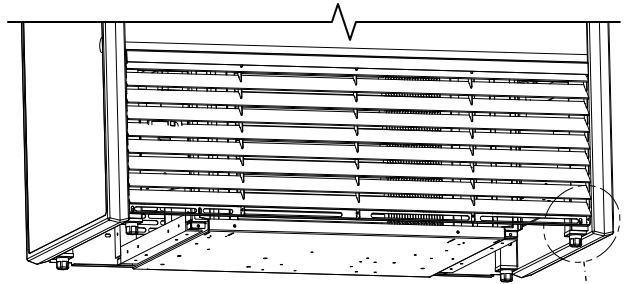

One Screw at Each End Holds Front Grille to Case

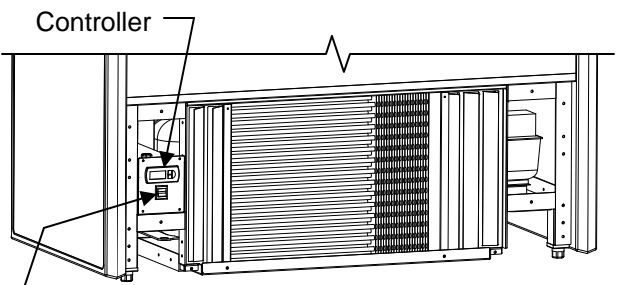
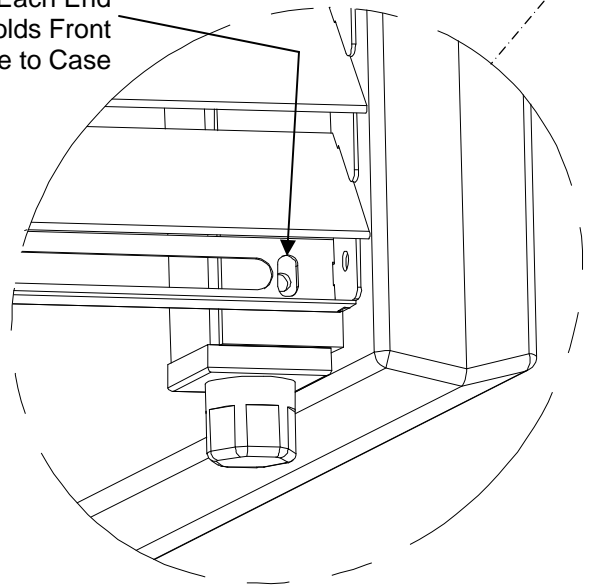

Main Power Switch

View of Condenser Coils After Removal of Front Grille

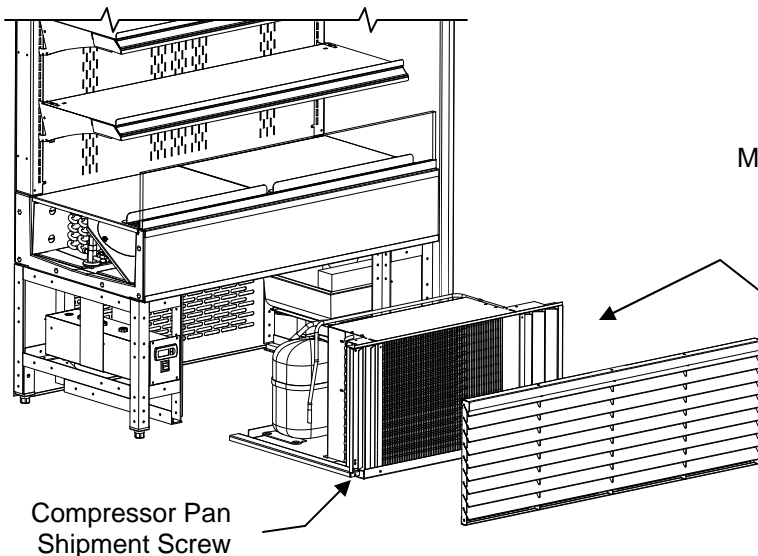

Compressor Pan Shipment Screw

View at left is of Refrigeration Assembly Slid Out From Under Case

## CHECK EVAPORATOR COIL FAN DISCHARGE / TXV [THERMOSTATIC EXPANSION VALVE]

### **1. Evaporator Coil Fan Discharge**

When Main Power Switch is turned on, Refrigeration Assembly will energize (see **CASE START-UP & REFRIGERATION ASSEMBLY ACCESS** section).

- Evaporator coil fans should turn on. From inside of the case, check for discharge air from front baffle to confirm that the fans are functioning properly.
- When the case is in a start up mode or has been idle for a long period of time, the unit will require 75 minutes of run time to pull-down temperature.
- See below illustration.

### **2. TXV [Thermostatic Expansion Valve]**

- TXV is under TXV access panel.
- Decking must be removed for access.
- TXV cover must also be removed for access (remove two thumb screws).
- See illustration below.
- Note: Standard cases have TXV at customer-left. For cases with EnergyWise, TXV is at customer-right.

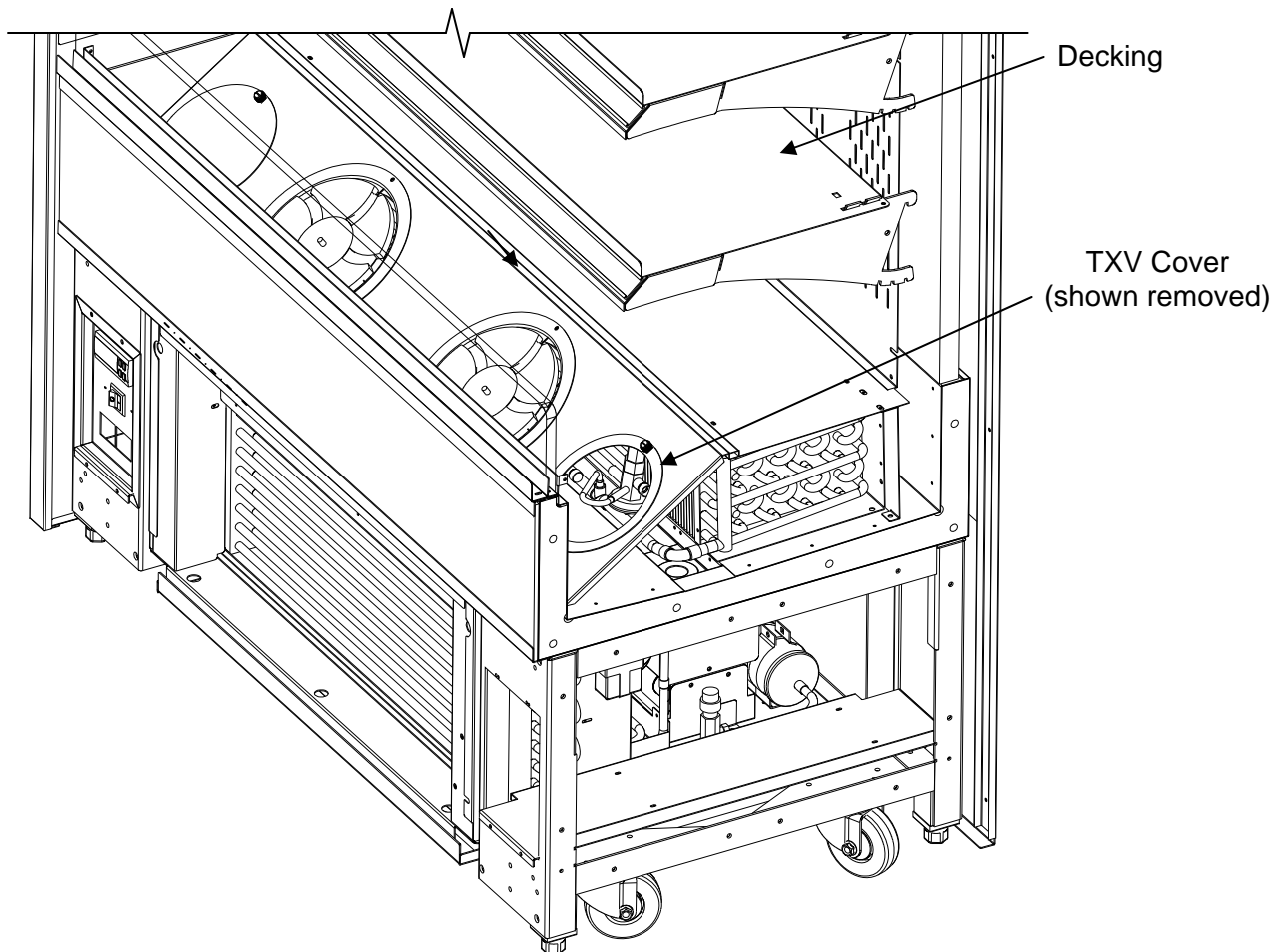

**Case shown with End Panel, Decking, and TXV Cover removed.**

**Note: Illustration above has TXV at customer right. Your case (if standard / non-EnergyWise refrigeration package) will have TXV accessible at customer-left.**

## HONEYCOMB AIR DIFFUSER ACCESS

### **1. Honeycomb Air Diffuser Access**

- Honeycomb is located in discharge air duct.
- See illustration below.
- Note: Depending upon model chosen, illustrations shown below may not exactly reflect every design feature or option as yours.

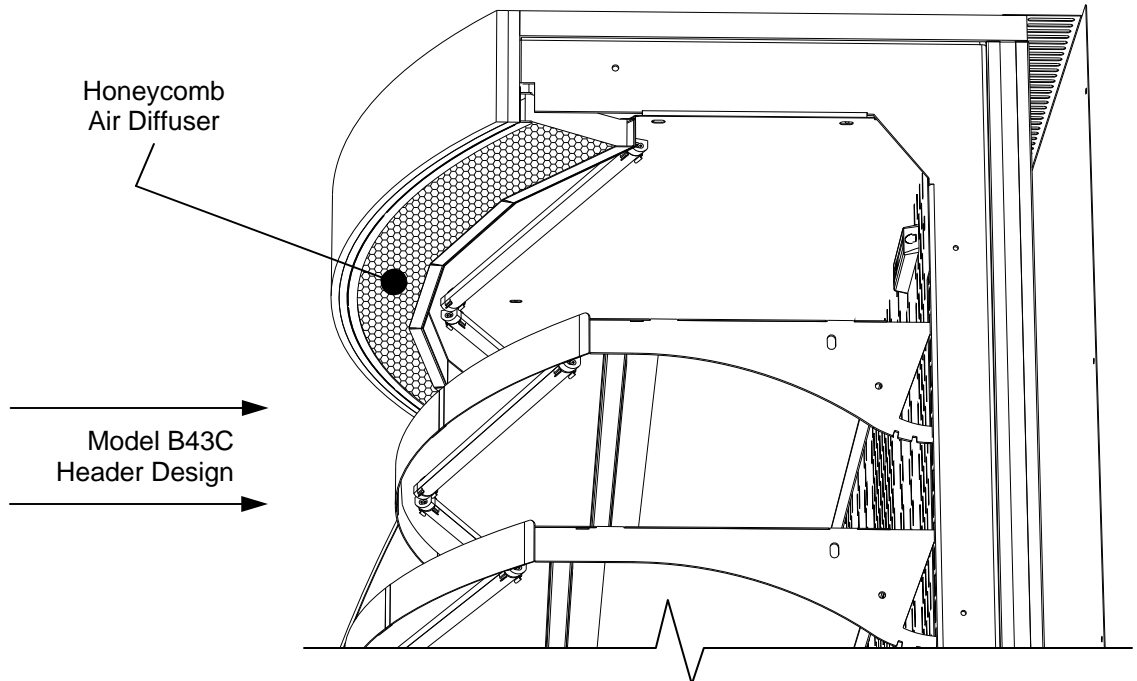
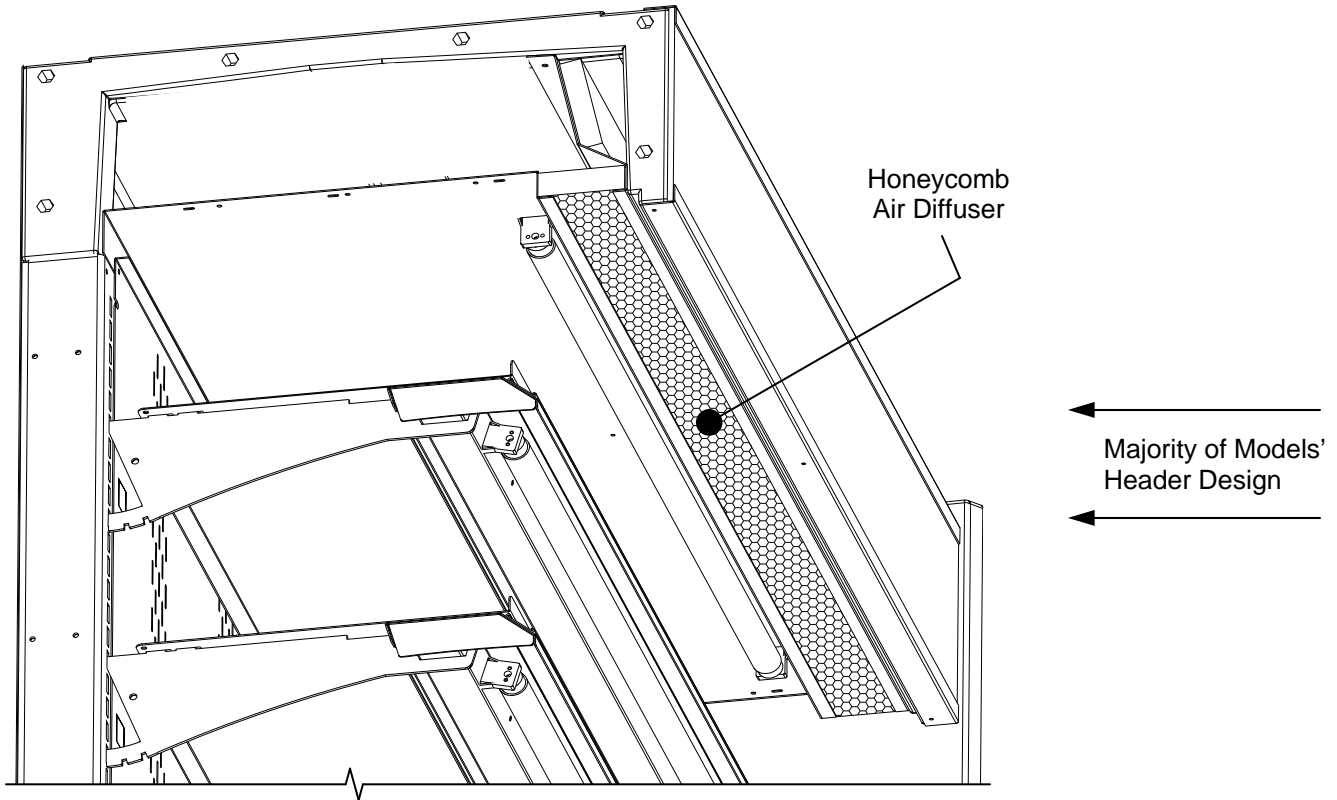

### **2. Honeycomb Air Diffuser Removal**

A. Wedge a non-metallic device of suitable strength (such as a ballpoint pen) between the honeycomb and the end panel.

Caution! Use care not to dislodge the heating wire (that prevents condensation on the lamp assembly).

B. Apply pressure to collapse the honeycomb to allow it to be pulled out of honeycomb retainer.

C. Carefully pry downward and away from the honeycomb retainer.

1. Use SCC supplied brush to reach in and, with outward sweeping motion, pull any crumbs or residue out of honeycomb area.

2. Clean honeycomb with warm water and soap solution. Submerge if necessary. Use brush to dislodge stubborn or sticky residue. Dry by using vacuum's blow mode (vs. suction mode).

### **3. Honeycomb Air Diffuser Installation**

D. Squeeze honeycomb to allow it to fit into the honeycomb retainer.

E. Carefully slide honeycomb into place.

F. Adjust honeycomb so that it fits flat against retainer. It must not be wavy or out of position.

Note: For honeycomb air diffusers in other locations, these same general instructions apply.

Photos below may not reflect the exact layout or design of your particular honeycomb air diffuser.

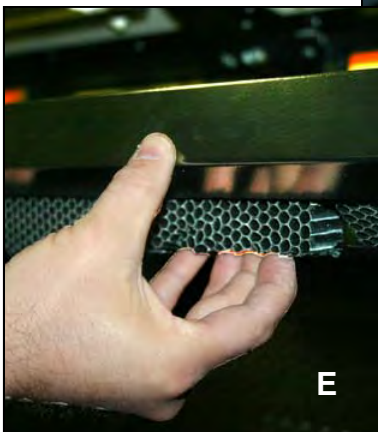
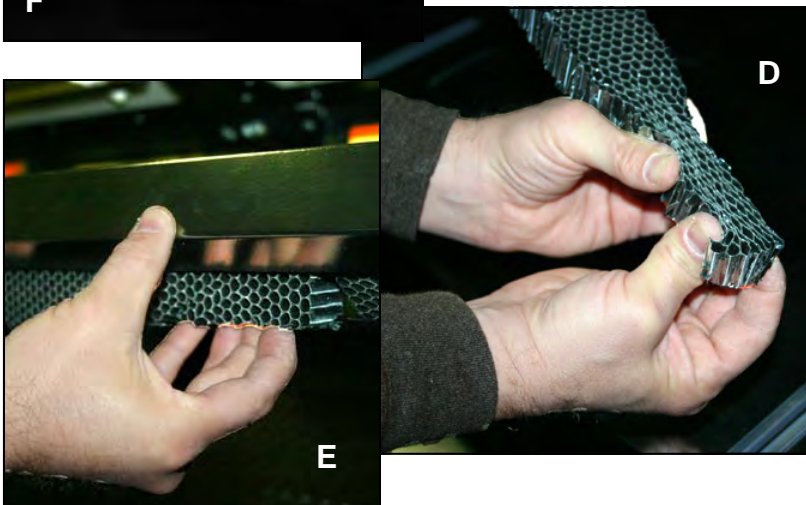
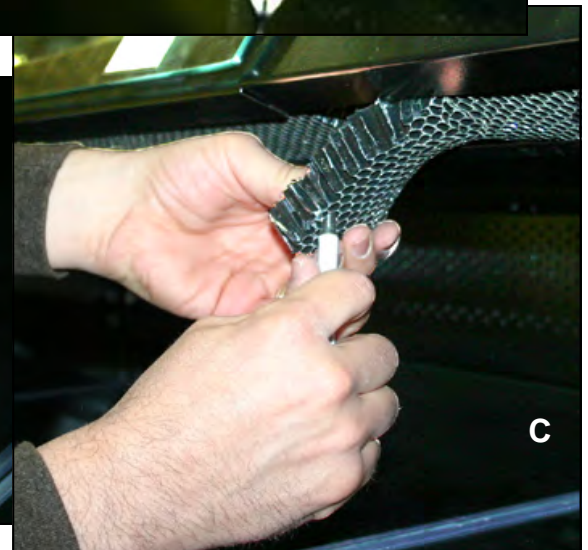
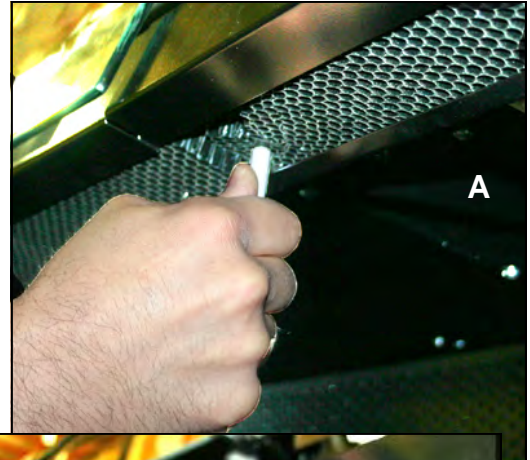

**1. Light Fixtures - Fluorescents**

**Warning! Disconnect power before providing maintenance and service to unit.**

**Caution: Lights have been treated to resist breakage and must be replaced with similarly treated lights.**

Light switch is located at customer-left of case just under header, behind honeycomb. It is to the left of the header light socket.

- See illustration directly below.
- Turning on light switch will turn on ALL lights in entire case.

Light fixtures are to be located on underside of shelf assembly, at the top inside of case, and lower front nose of case.

Removal of lamp:

- Rotate lamp (1/4-turn) either direction to disengage (upper or lower) pins/contacts from lamp-mounting sockets.
- Remove bulb by applying even pressure from back side at the bulb ends and pulling the remaining contact from sockets.

Installation of lamp:

- Align pins with slot.
- Insert pins into socket by rotating the bulb 1/4-turn to secure either the (upper or lower) pin contacts into the sockets.
- Rotate remaining bulb contacts (1/4-turn) into remaining lamp mounting socket contacts.

>> See next page for Mini-LED lighting specifics

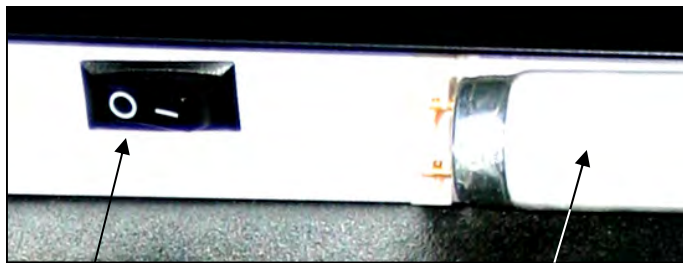

Light Switch

Header Light



Shelving Lights

99742-62

## 2. Light Fixtures - Mini-LEDs

**Warning!** Disconnect power before providing maintenance and service to unit.

**Caution:** When replacing mini-LED lights, you must replace with similar lights.

Light switch is located at customer-left of case under header, behind honeycomb.

- See illustration below-left.
- Turning on light switch will turn on ALL lights in entire case.

### Removal / Replacement of Mini-LED Light Fixtures

*Removal of lamp:*

- Mini-LED lights rarely require change-out.
- Contact Structural Concepts' Technical Service Department for replacement parts (see the Technical Service section of operating manual).

*Replacement of lamp:*

- To replace Mini-LED Light Fixture, disconnect existing light from its brackets. Replace.
- Note: Mini-LED Light and Plug must be connected in a specific manner or they will not work.
- Make certain that oval form of plug connects to oval form of Mini-LED end cap.
- See illustrations immediately below.

>> See previous page for specifics pertaining to fluorescent lighting.

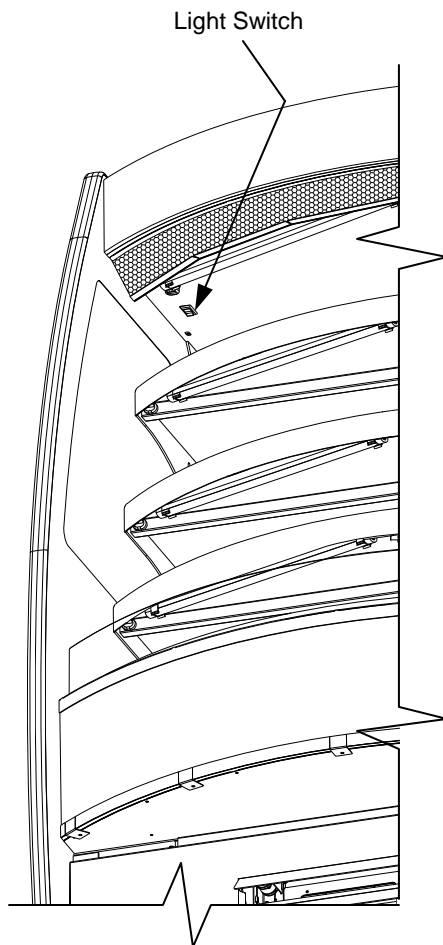
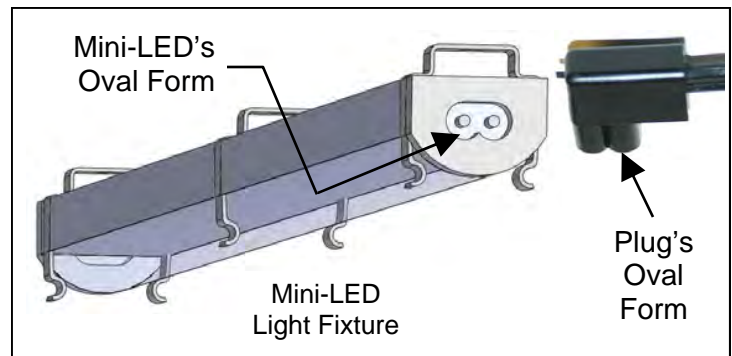

--- Case Front of Model B43C ---

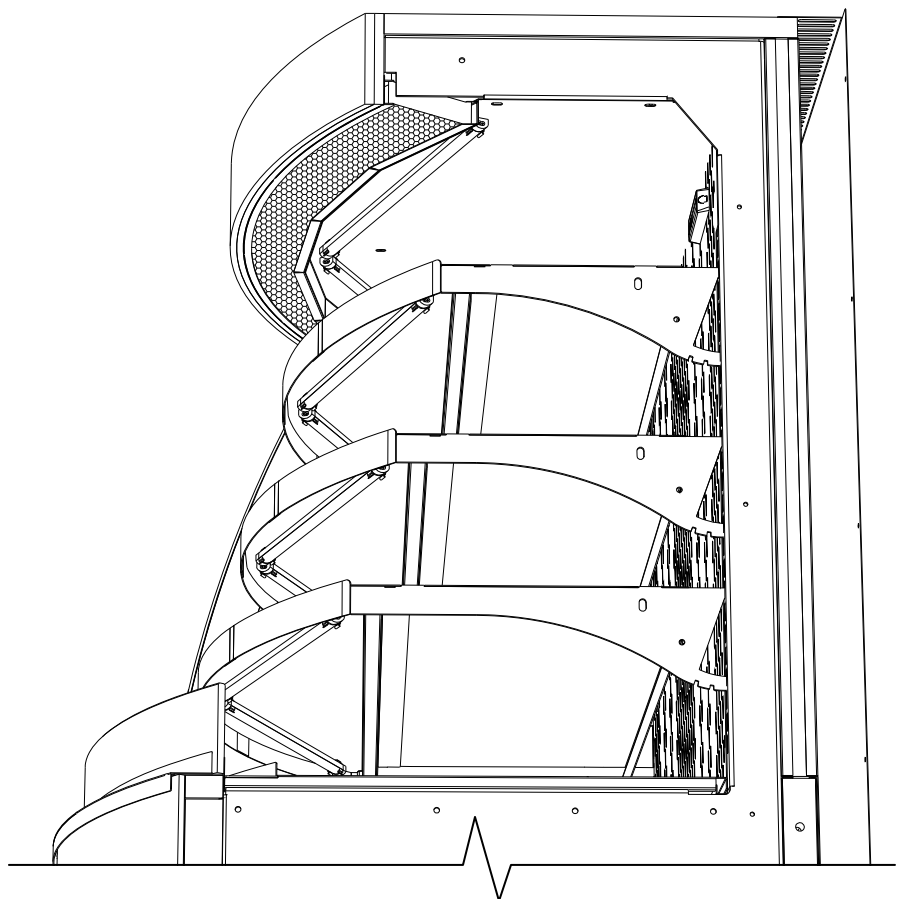

--- Case Right Side of Model B43C ---

**OPTIONAL ROLL-DOWN SECURITY COVER - MODEL B4732 ILLUSTRATED / YOUR MODEL MAY VARY**

**Roll Down Security Cover (Optional): Shown Extended**

- Optional roll down security cover has two handles for grasping, lowering and raising.
- After roll-down cover is lowered, key may be turned clockwise to lock latch into strike bracket.
- Turn counter-clockwise to unlock.
- Keep keys in safe and secure place.

Views Below Shown Partially Disassembled With Transparent Components For Illustrative Purposes Only

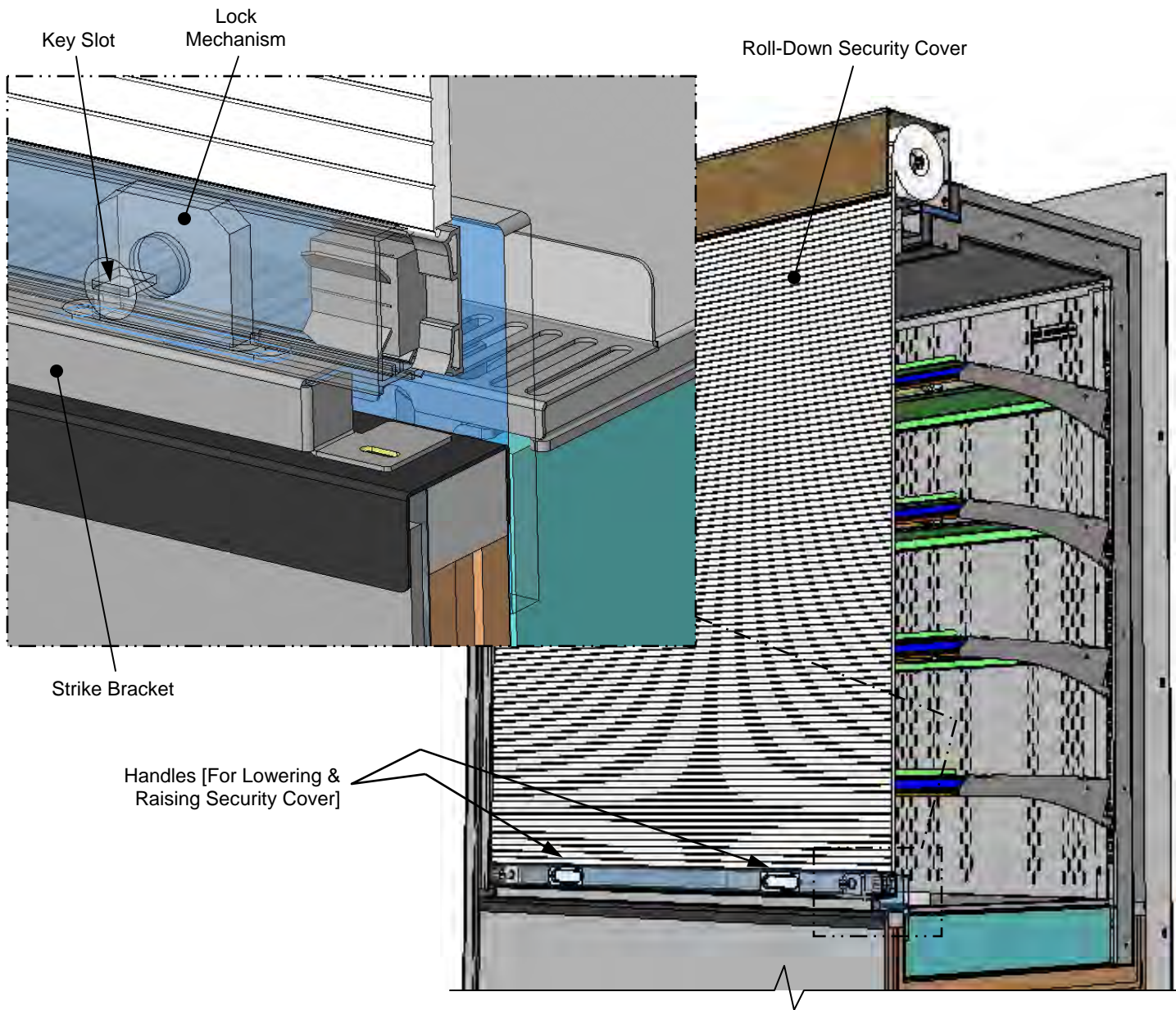
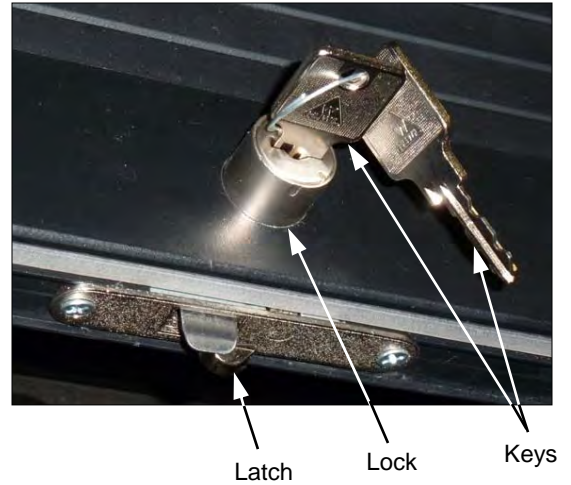

**Wall Spacing / Rear Venting - Model B43C Only**

**Caution:** Venting is an integral part of case temperature management. Do not remove rear panel!

**Rear Grille:** Rear grille may be removed (by removing 4 screws) for service or maintenance of condenser unit. Return rear grille to case rear when completed.

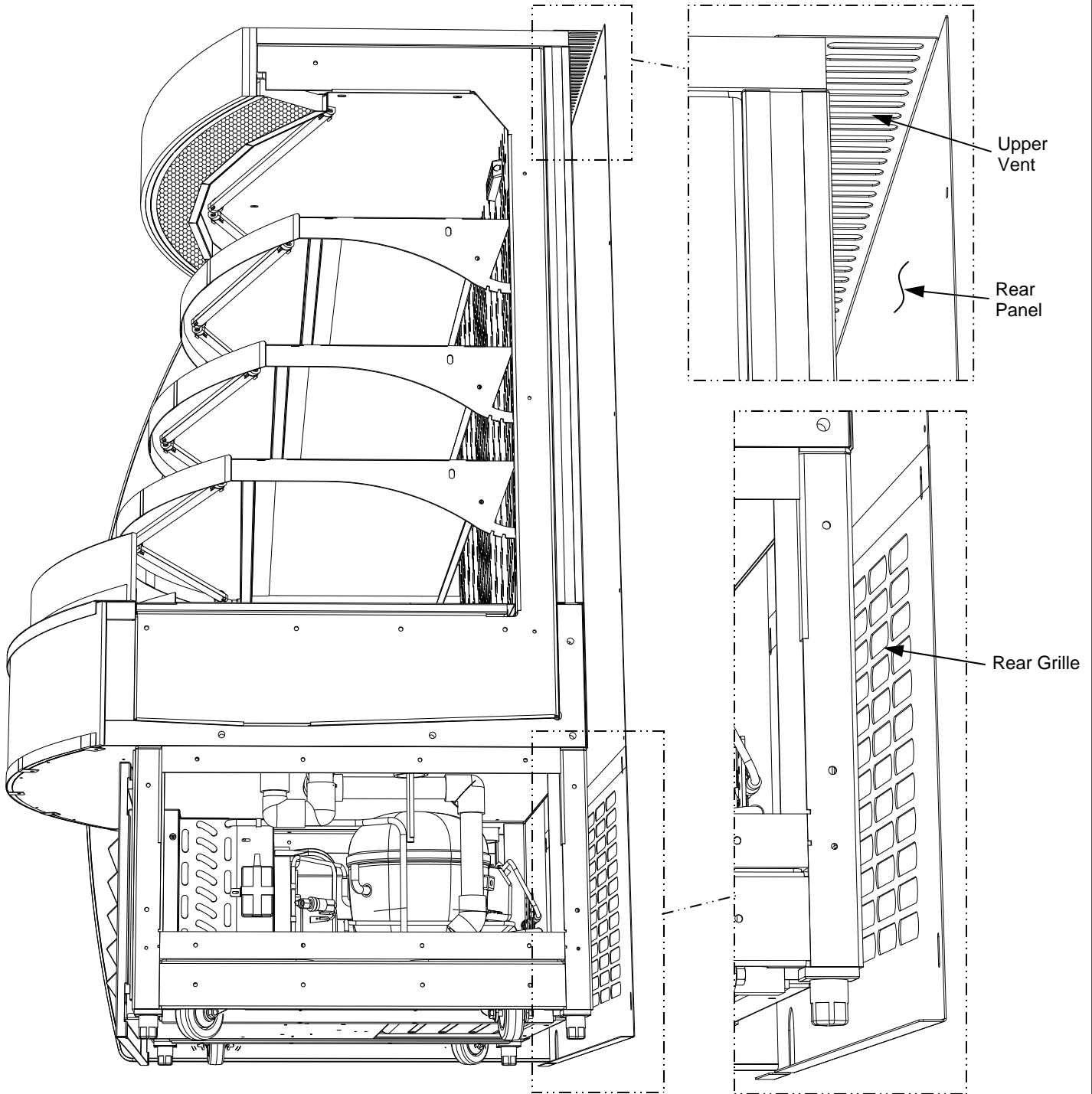

--- Case Right Side of Model B43C ---

## CONDENSATE PAN ACCESS: STANDARD UNITS

### Condensate Pan Access

**Warning! Disconnect power before providing maintenance and service to unit.**

First, remove the Front Grille and slide out the Refrigeration Assembly. See **FRONT GRILLE ACCESS / CHECK CONDENSER PAN / REFRIGERATION ASS'Y / TURN ON POWER** section in this operating manual for instructions.

- Unplug the condensate pan from its outlet.
- Remove the two (2) screws holding the condensate pan foot to the condensate pan support (see illustration below).
- Carefully slide the condensate pan off from the condensate pan support.
- When done servicing or cleaning, return and reconnect in reverse order it was removed.

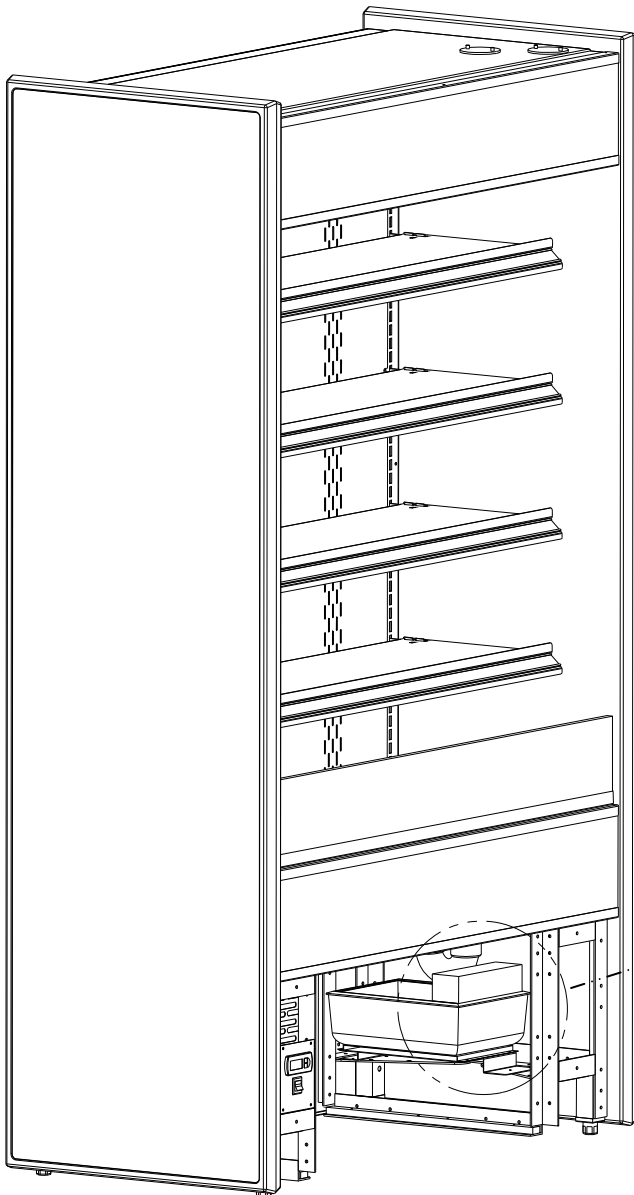

---- Case Front (Refrigeration Assembly Removed) ----

**Note:** Depending upon your particular refrigeration package, removable, electric-coil condensate pan may not be part of case. Cases with EnergyWise refrigeration packages DO NOT have a removable electric-coil condensate pan.

Two (2) Condensate Pan Screws (Connecting Pan Foot To Support)

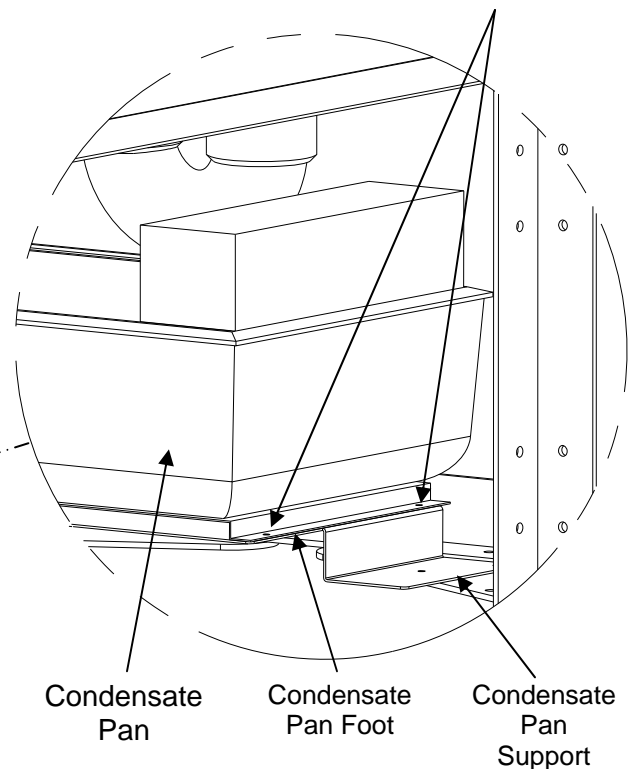

## CONDENSATE PAN ACCESS: REMOTE UNITS WITH CONDENSATE PANS ONLY

### Condensate Pan Access and/or Removal

- **Caution:** Only trained service providers are to provide maintenance and service to unit.
- **Warning!** Disconnect power before providing maintenance and service to unit.
- To access, remove the front panel. Simply lift panel up and off (no screw removal is required).
- To service or clean, unplug the condensate pan from its outlet.

- Remove the screws holding the condensate pan foot to the condensate pan support (see illustration below).
- Carefully slide the condensate pan off from its support.
- When done servicing or cleaning, return and reconnect in reverse order it was removed.

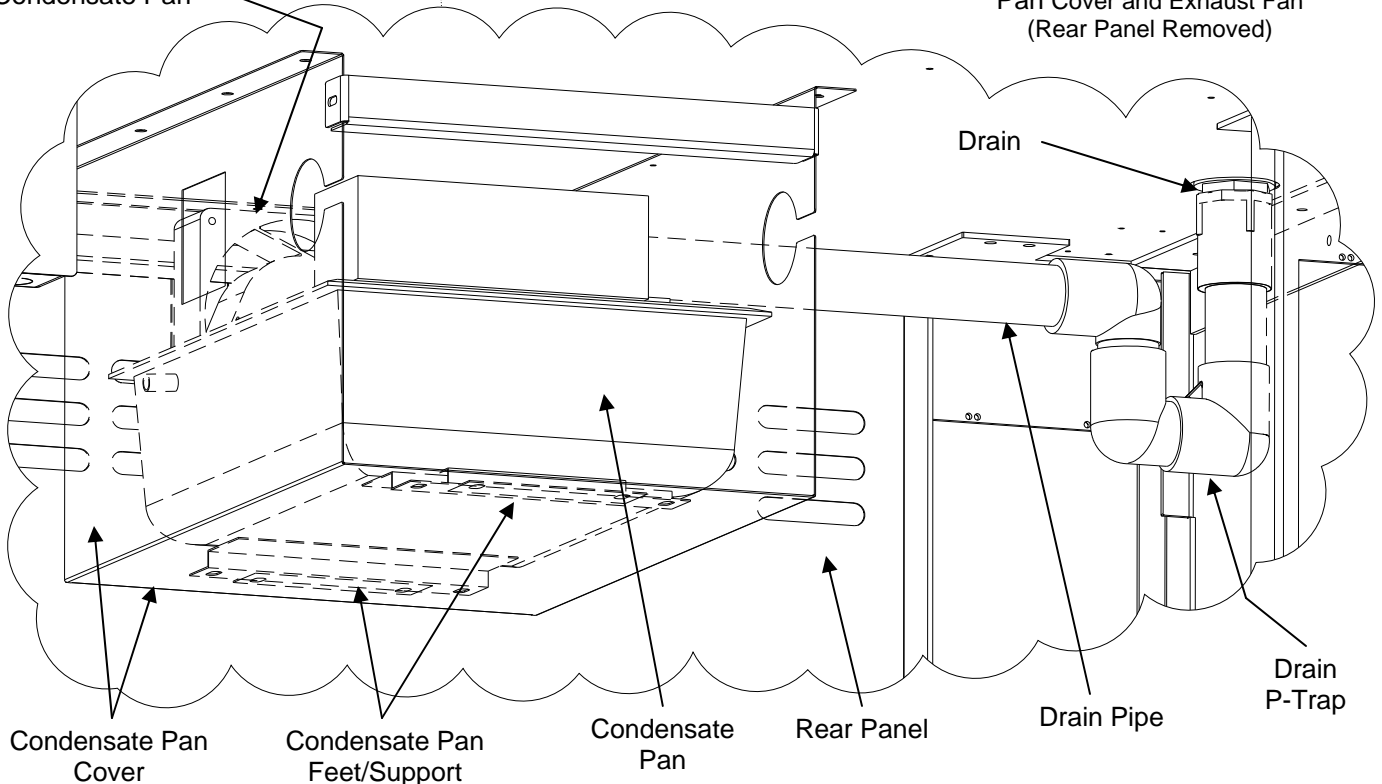
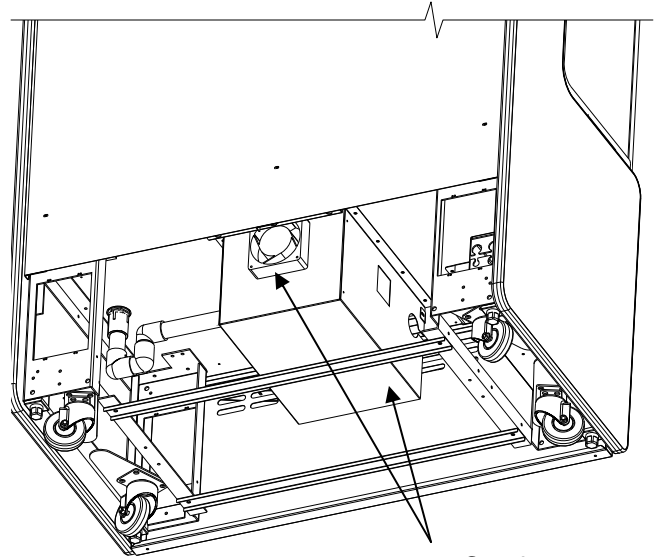
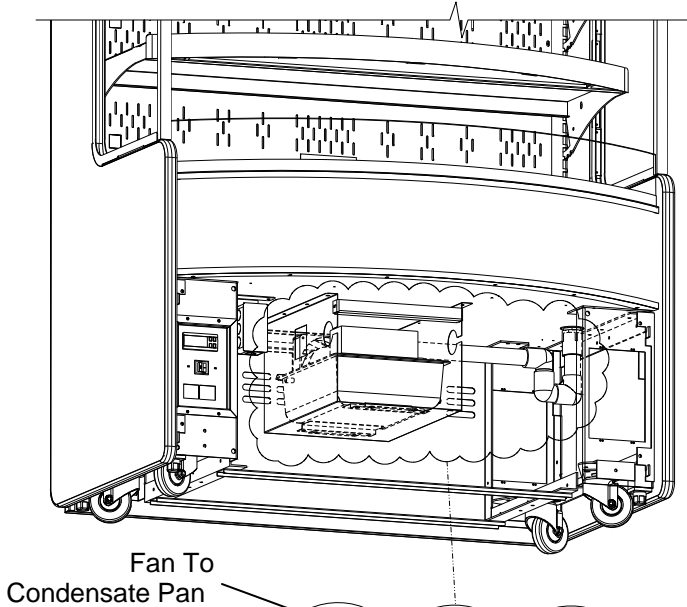

# SELF-CONTAINED HOT GAS LOOP CONDENSATE PACKAGE LAYOUTS

## Self-Contained Hot Gas Loop Condensate Packages

- **Caution:** Only trained service providers are to provide maintenance and service to unit.
- **Warning!** Disconnect power before providing maintenance and service to unit.

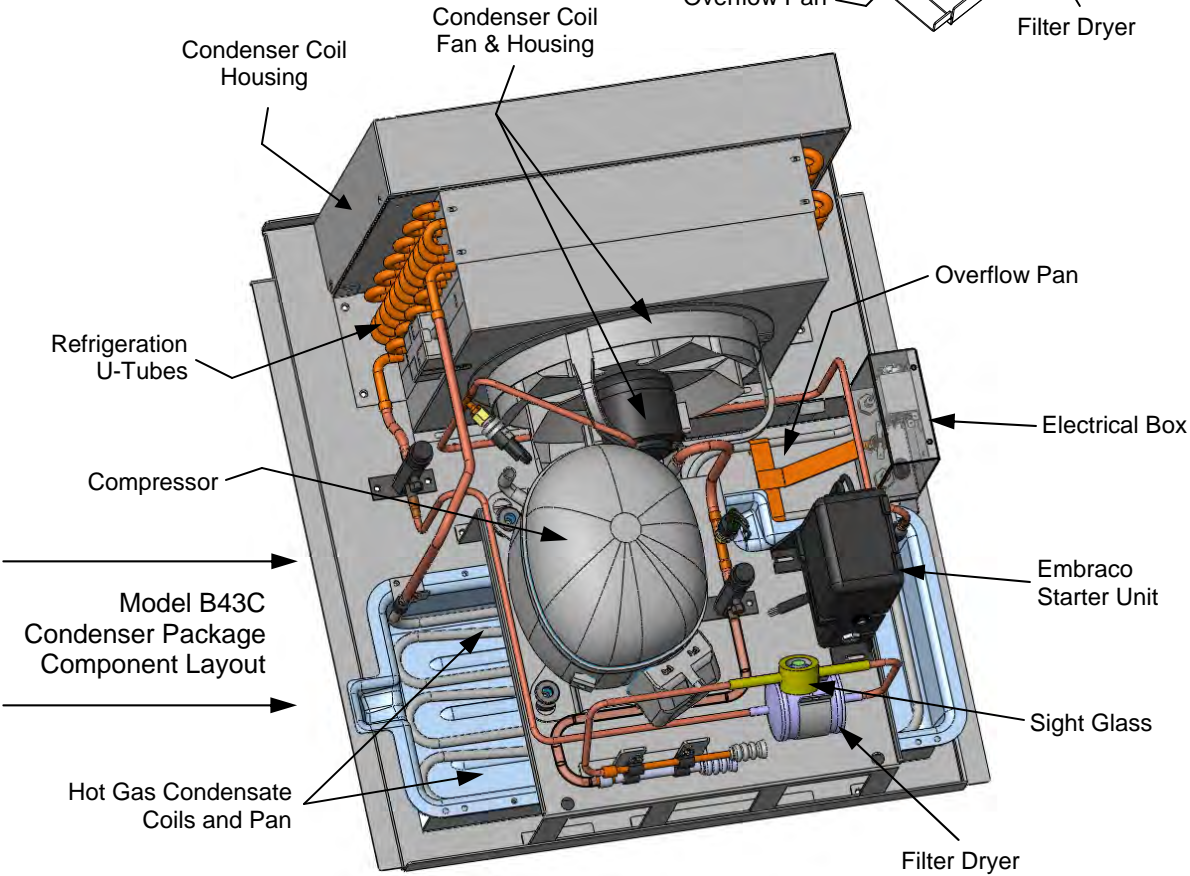
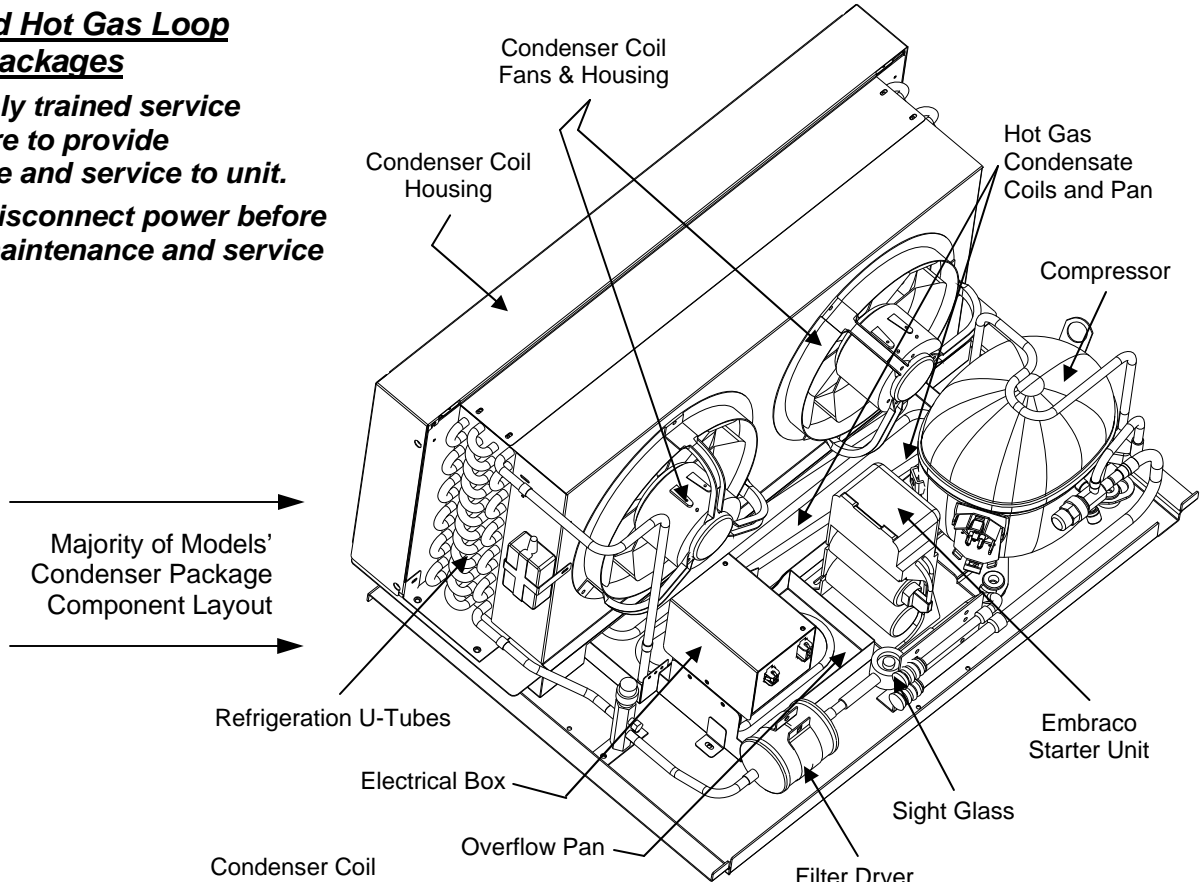

**LOAD LEVEL GUIDE / TEMPERATURE GUIDE [MODEL B42 SHOWN / APPLICABLE TO OTHERS]**

**LOAD LEVEL & TEMPERATURE GUIDE**

**CAUTION 1:** TO PREVENT PRODUCT FROM FREEZING OR BECOMING OVERLY WARM, ALLOW AT LEAST 1" SPACE BETWEEN PRODUCT AND UPPER SHELF LIGHTS.

**CAUTION 2:** TO PREVENT PRODUCT FROM FREEZING OR BECOMING OVERLY WARM, DO NOT BLOCK AIR RETURN GRILLE WITH PRODUCT.

- IMPROPER PRODUCT PLACEMENT PREVENTS PROPER AIRFLOW CAUSING PRODUCT TO FREEZE OR BECOME OVERLY WARM.
- FOLLOW THESE PRODUCT PLACEMENT GUIDELINES TO MAINTAIN DESIRED PRODUCT TEMPERATURES.

**NOTE:** SEE VIEW AT RIGHT FOR PRODUCT TEMPERATURE RANGE AT FRONT vs. REAR OF CASE

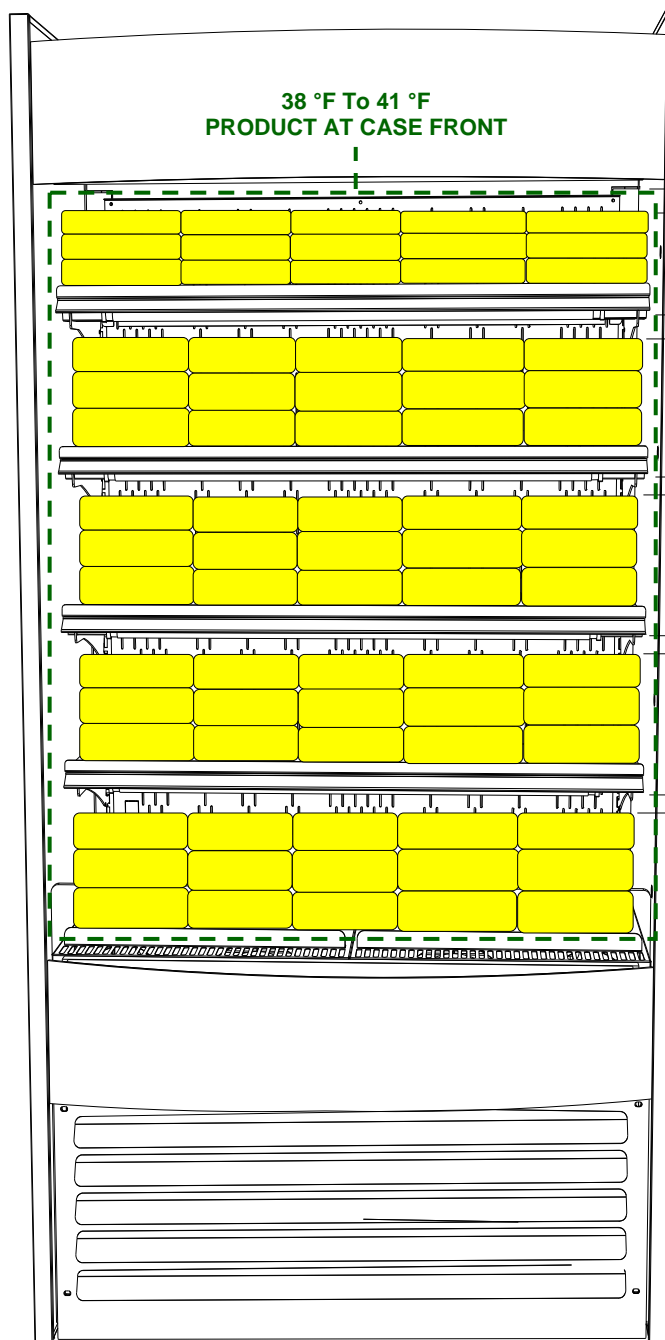

**MODEL B42 FRONT SHOWN [APPLIES TO ALL MODELS]. CASE IS FULLY ASSEMBLED AND FILLED WITH PRODUCT FOR ILLUSTRATIVE PURPOSES ONLY.**

**PACKAGED PRODUCT**  
**TEMPERATURE RANGE**

**CAUTION 1:** TO PREVENT PRODUCT FROM FREEZING OR BECOMING OVERLY WARM, ALLOW AT LEAST 1" SPACE BETWEEN PRODUCT AND UPPER SHELF LIGHTS.

**CAUTION 2:** TO PREVENT PRODUCT FROM FREEZING OR BECOMING OVERLY WARM, DO NOT BLOCK AIR RETURN GRILLE WITH PRODUCT.

**38 °F To 41 °F PRODUCT AT CASE FRONT**  
**28 °F To 35 °F PRODUCT AT CASE REAR**

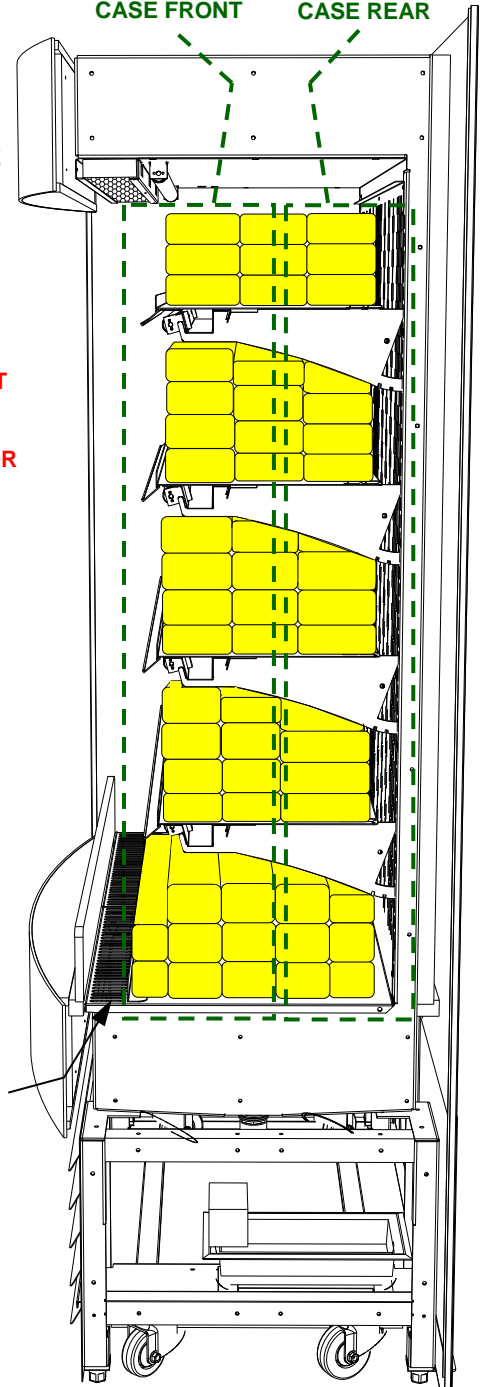

**MODEL B42 SIDE SHOWN [APPLIES TO ALL MODELS]. CASE IS PARTIALLY DISASSEMBLED AND FILLED WITH PRODUCT FOR ILLUSTRATIVE PURPOSES ONLY.**

**CLEANING SCHEDULE - TO BE PERFORMED BY STORE PERSONNEL**

AREA TO BE CLEANED	FREQUENCY	INSTRUCTIONS
Case Exterior	Daily	<b>Acrylic Air Deflector:</b> Clean with a warm water and mild soap solution and soft cloth. Never use ammonia-based cleaners on acrylic.
	Weekly	<b>Condenser Coil:</b> Vacuum or brush grille area on back of case. See <i>PREVENTIVE MAINTENANCE, Page 1 of 3</i> for illustrations.
Case Interior	Daily	<b>Shelves &amp; Decks:</b> Wipe off with moist cloth.
	Weekly	<b>Tub &amp; Drain:</b> Vacuum tub under decks. Clean with soap and water solution. Wipe dry with clean cloth. Keep drain free of debris to prevent clogging.
	Monthly	<b>Air Return Grille and Fan Shroud Area:</b> See Illustration below. 1) Turn off power. 2) Remove decks from case. 3) Clean with moist cloth.
	Quarterly	<b>Honeycomb:</b> Remove the honeycomb. Vacuum, then clean with warm water and soap. See <i>HONEYCOMB AIR DIFFUSER</i> section of this manual for specifics.

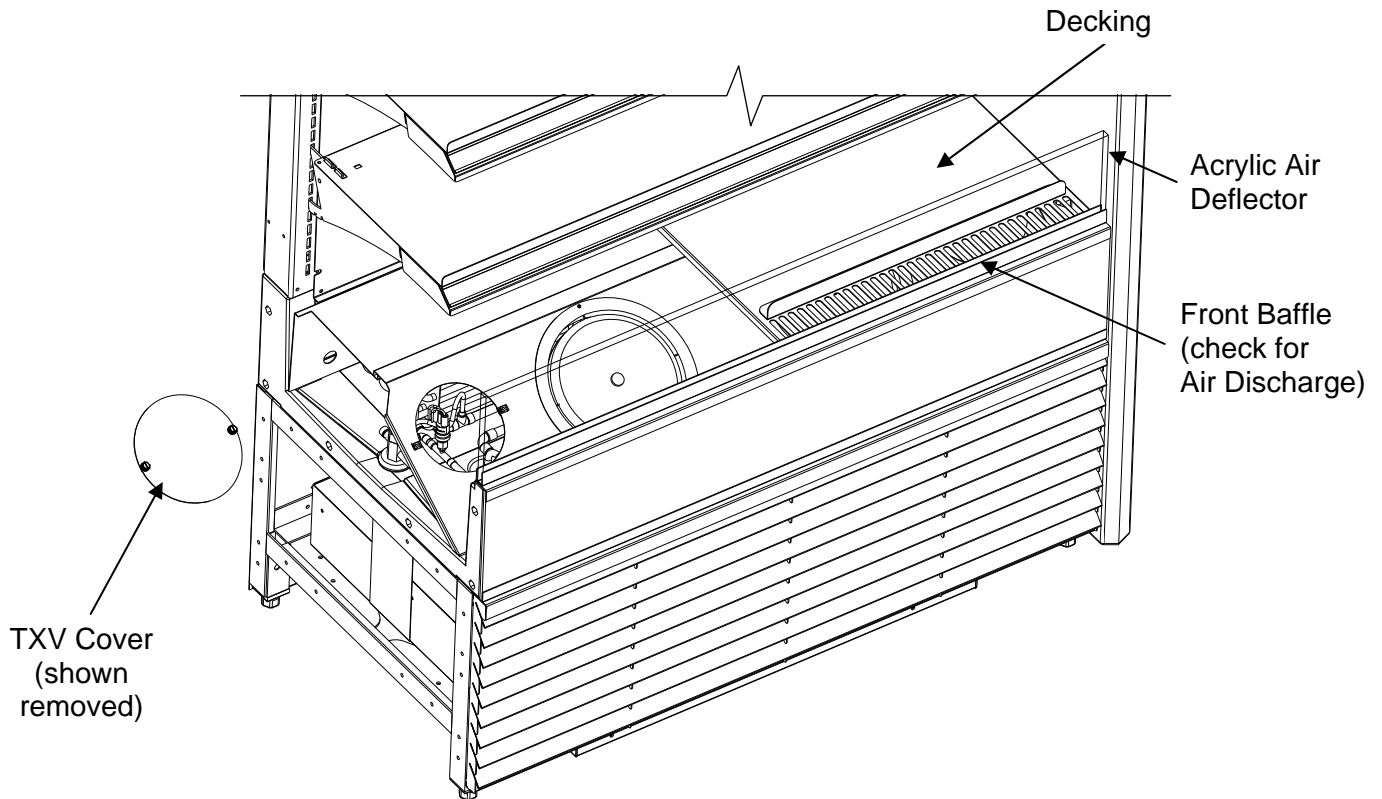

**Above Illustration (With TXV at Customer-Left) is ONLY on Cases With Standard Refrigeration Package (With Standard Condensate Pan, etc.)**

**WARNING! TURN OFF CASE BEFORE PERFORMING PREVENTIVE MAINTENANCE!**

PREVENTIVE MAINTENANCE	FREQ.	INSTRUCTIONS
Case Exterior	Quarterly	<p><b><u>Standard Condenser Coil and Refrigeration Package:</u></b></p> <p><i>Warning! Disconnect power from case before beginning!</i></p> <p><u>Note:</u> The vacuum 'blow mode' is to be used when cleaning the condenser coil. Follow these steps:</p> <ol style="list-style-type: none"> <li>Remove front grille (by removing thumbscrews).</li> <li>Slide out refrigeration assembly.</li> <li>Use vacuum and brush to dislodge and remove dust on and in coil.</li> <li>Place damp rags around condensing fan motor brackets to collect airborne dust.</li> <li>Using vacuum (in 'blow mode') to blow air through condenser coils and into fans. Blow entire surface of condensing coils to assure that all entrenched dust is removed. <b>Caution! Coil fins are sharp!</b></li> <li>Use a clean cloth and hot water with soap solution to wipe down dust and residue that may form on all parts.</li> <li>Slide refrigeration assembly back under case.</li> <li>Replace rear grille to case (reattach thumbscrews).</li> </ol> <p><b>See illustrations below.</b></p> <p><b>Note: See <u>SELF-CONTAINED HOT GAS LOOP CONDENSATE PACKAGE LAYOUTS</u> section in manual for EnergyWise condenser units.</b></p>

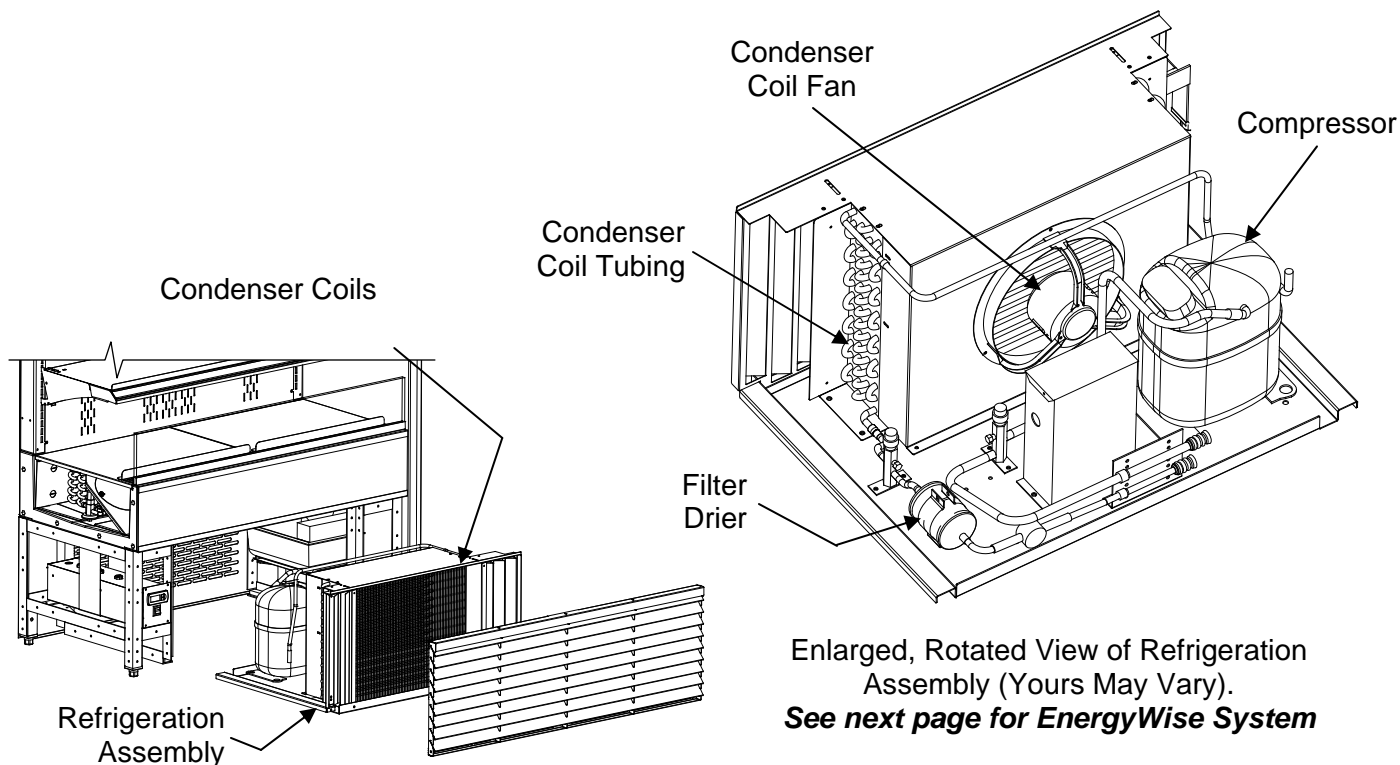

**WARNING! TURN OFF CASE BEFORE PERFORMING PREVENTIVE MAINTENANCE!**

PREVENTIVE MAINTENANCE	FREQUENCY	INSTRUCTIONS
Case Exterior	Quarterly	<p><b><u>Under Case Cleaning:</u></b> Whenever Refrigeration Assembly is removed from underside of case, vacuum (or use broom) under the case to remove all dust, debris and dirt that may collect under case.</p>
	Quarterly	<p><b><u>Condensate Pan:</u></b></p> <ul style="list-style-type: none"> <li>• <i>Warning! Condensate Pan Is HOT! Disconnect power from case and allow to cool before cleaning the Condensate Pan!</i></li> <li>• See <b>CONDENSATE PAN ACCESS</b> section for in-depth instructions on accessing the Condensate Pan.</li> <li>• Condensate pan is removable from case (unless your case has EnergyWise refrigeration package as shown below).</li> <li>• Use a scrub-brush and a de-scaling solution such as CLR® (to prevent corrosion, lime and rust). Follow instructions as to proper dilution, safety precautions and scrubbing method.</li> <li>• After thoroughly cleaning pan with scrub-brush and solution, rinse thoroughly with clean water and then wipe dry.</li> <li>• Slide Refrigeration Assembly back under case (at front).</li> <li>• Replace Front Grille to case.</li> </ul>

**WARNING! TURN OFF CASE BEFORE PERFORMING PREVENTIVE MAINTENANCE!**

PREVENTIVE MAINTENANCE	FREQUENCY	INSTRUCTIONS
Case Interior	Quarterly	<p><b><u>Tub, Coil, Drain, Fan Blades, Motors, Brackets:</u></b>  <i>Disconnect power from the case before cleaning the Tub, Coil, Fan, Motor and Drain Area!</i></p> <ul style="list-style-type: none"> <li>• Remove Decking, Sub-Deck (if any) and Fan Shroud.</li> <li>• Use vacuum to clean Condenser Coils.</li> <li>• Clean Tub, Coil and Drain with warm water, clean cloth, brush and mild soap solution.</li> <li>• Remove any debris that may clog drain.</li> <li>• Wipe down Fan Blades, Motors and Brackets with moist cloth.</li> <li>• Replace Decking, Sub-Deck (if any) and Fan Shroud.</li> </ul>
	Quarterly	<p><b><u>Honeycomb:</u></b> Remove the honeycomb. Vacuum, then clean with warm water and soap. See <b>HONEYCOMB AIR DIFFUSER</b> section of this manual for specifics.</p>

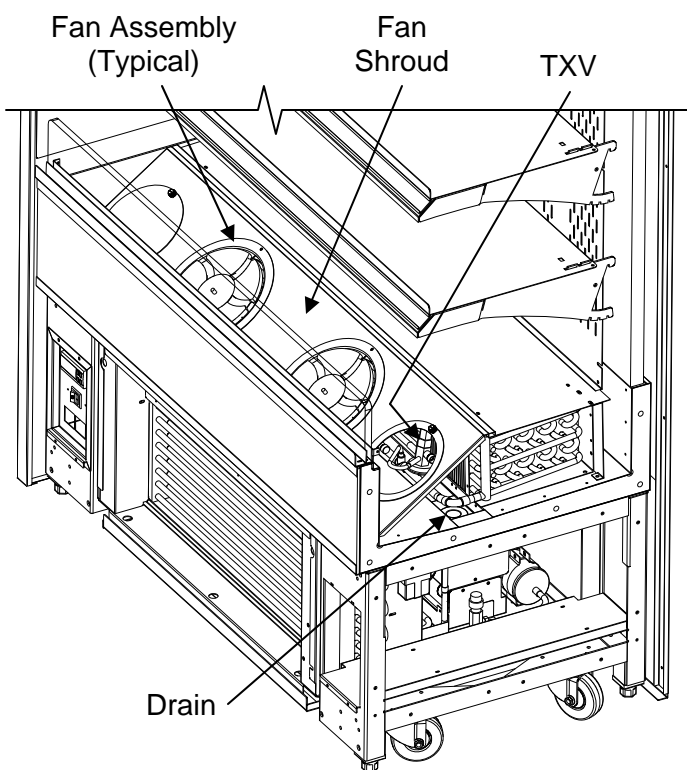

Case shown with End Panel, Deck, and TXV Cover removed.

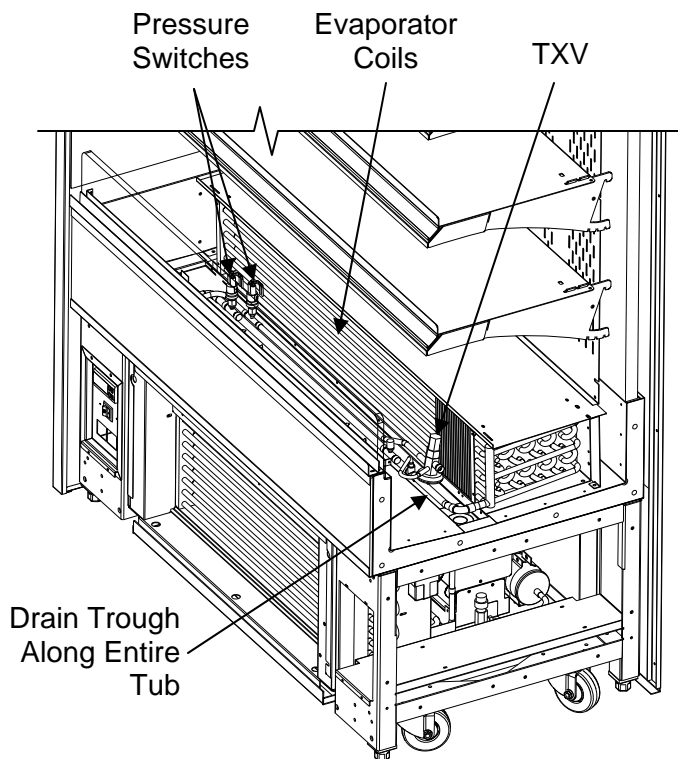

Case shown with End Panel, Decks, Fan Shroud and TXV Cover removed.

**Above Illustrations (With TXV at Customer-Right) is ONLY on Cases With EnergyWise Refrigeration Package (With Hot Gas Loop Condensate System)**

CONDITION	TROUBLESHOOTING
<b>Case Not Lining Up</b>	See <i>Installation</i> section in this manual for instructions on properly aligning case (alongside other cases) and adjusting levelers.
<b>Water Is On The Floor</b>	<p><b>Caution!</b> Water on flooring can cause much damage! Until cause is determined (and repaired), follow these procedures:</p> <ul style="list-style-type: none"> <li>• Use wet-dry vacuum (or mop &amp; bucket) to remove standing water.</li> <li>• Use 'catch pans' for water to drain into. Swap out regularly until case has completely drained.</li> </ul> <p><b>Note:</b> See <i>Drain, Hose and Bracket Placement Illustrations</i> sheet in this manual for views of different condensate systems used in display cases.</p>
	Check that the drain trap is free of debris.
	Check that the drain hose is correctly positioned over condensate pan (or floor drain, for remote units).
	Check store conditions. To prevent condensation in NSF® Type 1 environments, maximum conditions are to be 55% humidity / 75° Fahrenheit. For NSF® Type 2, maximum conditions are to be 60% humidity / 80° Fahrenheit. See serial label (at case rear near main power switch) for NSF® Type of your case.
	Check condensate pan float for proper operation (electric condensate trays).
	Check that condensate pan is properly plugged in or connected.
	<p><b>Caution!</b> Condensate pan may be malfunctioning. If so, water will overflow pan and seep onto flooring causing damage! Until condensate pan is functioning (or is replaced), follow these procedures:</p> <ul style="list-style-type: none"> <li>• Use wet-dry vacuum (or mop &amp; bucket) to remove standing water.</li> <li>• Use 'catch pans' for water to drain into. Swap out regularly until case has completely drained.</li> </ul>
	<p><b>Caution!</b> Disruption of power can cause water to overflow pan and seep onto flooring causing damage! Check that power to case is constant. Until power is restored, follow these procedures:</p> <ul style="list-style-type: none"> <li>• Use wet-dry vacuum (or mop &amp; bucket) to remove standing water.</li> <li>• Use 'catch pans' for water to drainage. Swap out regularly until drainage of case is complete (or until power is restored).</li> <li>• When power to case is restored, condensate pan should function properly and water will no longer overflow onto flooring.</li> </ul>
	<p><b>Caution!</b> Wicking material (if any) on your particular hot gas loop condensate tray may be dirty or worn and need replacement.</p> <ul style="list-style-type: none"> <li>• Slide condensate package out from under unit.</li> <li>• After refrigeration system has been carefully slid out, replace wicking material with new. If wicking material is not available, contact Structural Concepts®. See toll-free number at last page of this operating manual.</li> </ul>

CONDITION	TROUBLESHOOTING
<b>Fan Emits Excessive Noise</b>	Check that the case is aligned, level and plumb.
	Check evaporator fan for cleanliness.
	Unplug/power off fan motors. Check motor shaft for bearing wear.
	Check that fan motors are securely mounted in brackets.
	Verify that fan blades are securely mounted to fan motor.
	Check that nothing is preventing blade rotation.
	Check that the fan shroud is properly secured.
<b>Fans Are Not Working</b>	Check that the MAIN power switch is on.
	Check that fans are plugged in at the fan shroud.
	Check for foreign material obstructing fan performance.
	Check that fan blades freely rotate within fan shrouds
	Check that power is going to fans
	Check that fan wiring is connected on terminal blocks.
<b>Digital Control Display Is Blank</b>	Check that the MAIN power switch is on.
	Check the circuit breaker box for tripped circuits.
<b>System Not Operating</b>	Check that the utility power is on.
	Check that the MAIN power switch is on.
	Check the circuit breaker box for tripped circuits.

CONDITION	TROUBLESHOOTING
<b>Case Lights Are Not Working</b>	Check that light switch is in the <i>on</i> position.
	Check that <b>ALL</b> of the light cords and plugs are properly connected. See <b><i>MAINTENANCE - LIGHT FIXTURES (LED LIGHT FIXTURES)</i></b> section.
	Service Technicians Only: Check voltage at LED drivers. If voltage is entering but not exiting, LED driver may be faulty.
<b>Control Display Is Flashing</b>	See your case's serial label for your model's specified settings. See <b><i>SERIAL LABEL LOCATION &amp; INFORMATION LISTED / TECH INFO &amp; SERVICE</i></b> for label location, etc.
<b>Case Is Not Holding Temperature</b>	If a large amount of warm product was added to the case, it will take time for the temperature to adjust. Unit needs product to be pre-chilled.
	Temperature changes during defrost mode but will return to normal. Fourth LED will indicate defrost cycle in progress.
	Check that case is not in sun or near a heat or air-conditioning vent. See <b><i>OVERVIEW / TYPE / COMPLIANCE / WARNINGS / PRECAUTIONS / WIRING / PLUGS</i></b> section in manual for adverse conditions/spacing issue parameters.
	If case is located near front doors, temperature fluctuation can hinder unit's ability to maintain temperature. See <b><i>OVERVIEW / TYPE / COMPLIANCE / WARNINGS / PRECAUTIONS / WIRING / PLUGS</i></b> section in manual for adverse conditions/spacing issue parameters.
	Check that condenser coil air filter (attached to rear grille) has been cleaned. See <b><i>GENERAL CLEANING [TO BE PERFORMED BY STORE PERSONNEL]</i></b> section in operating manual for instructions.
	Check that condenser coil has been cleaned.
	Check air return grilles for obstructions.
	Check sight glass for flashing and/or low charge.
	Check Set Point Temperature; it may be adjusted too high.
<b>Condensing Unit Is Not Operating</b>	Check that the power is turned on.
	Determine if temperature controller settings are properly set. See your case's serial label for your model's specified settings. See <b><i>SERIAL LABEL LOCATION &amp; INFORMATION LISTED / TECH INFO &amp; SERVICE</i></b> section in manual for label location, etc.

**TROUBLESHOOTING [BY TRAINED SERVICE PROVIDERS ONLY] - CONDENSING SYSTEM**

CONDITION	TROUBLESHOOTING
<b>Head Pressure Too High</b>	Check that the Condensing Coil is not dirty or covered.
	Check that Condensing Fans are working.
	Check that refrigerant is not overcharged.
	Check to verify that a non-condensable is not in the system.
	Check that Liquid Line Drier is not plugged.
	Check that there are no close-offs around Condensing Coil.
	Check Set Point Temp.; it may be adjusted too high.
	Check System Operating Temperatures.
	Check that Store Ambient Temperature isn't above maximum allowed. See <i>Overview and Warnings</i> Section.
<b>Head Pressure Too Low</b>	Check that Refrigerant Charge isn't too low.
	Check that Suction Pressure isn't too low.
	Check to verify that Compressor Valves aren't bad.

**TROUBLESHOOTING [BY TRAINED SERVICE PROVIDERS ONLY] - EVAPORATOR SYSTEM**

<b>CONDITION</b>	<b>TROUBLESHOOTING</b>
<b>Low Suction Pressure</b>	Check that the Refrigerant doesn't have a low charge.
	Check that Expansion Valve (TXV) isn't restricted.
	Check that Liquid Line or Filter isn't restricted.
	Check that Evaporator Motors are working.
	Check that High Superheat doesn't need adjusting.
	Check that the Thermostatic Element charge isn't depleted.
	Check that there is air no seepage of air around Condensing Coil.
	Check that the Coil is not iced up.
<b>High Suction Pressure</b>	Check that Refrigerant Charge isn't too high.
	Check that Compressor Valves aren't bad.
	Check that the Cooling Load isn't high.
	Check that Superheat Adjustment isn't low.
	Check TXV Bulb Installation a. Poor thermal contact. b. Warm location.
	Check Compressor: Low capacity means it is undersized for its application.

**Serial Label Location & Information Listed / Technical Information & Service**



- Serial labels are located near the electrical access on your case.
- Serial labels contain electrical, temperature & refrigeration information, as well as regulatory standards to which the case conforms.
- For additional technical information and service, see the *TECHNICAL SERVICE* page in this manual for instructions on contacting Structural Concepts' Technical Service Department.
- See images below for samples of both refrigerated and non-refrigerated serial labels.



888 E. Porter Rd · Muskegon, MI 49441

**ENCORE<sup>®</sup>** MODEL HV74RSS SCROLL  
SERIES SERIAL NO.

**FOR PARTS AND SERVICE**  
CALL 1-800-433-9489

3048256

CONFORMS TO UL STD 471  
CONFORMS TO NSF STD 7  
CERTIFIED TO CAN/CSA  
STD C22.2 NO 120

ELECTRICAL RATING	120/1/60 24A
REFRIGERANT	R404A AMOUNT ?? OZ
DESIGN PRESSURE	HIGH 450 LOW 200
MINIMUM CIRCUIT	30A
MAXIMUM OVERCURRENT	30A

**SAMPLE ONLY**

**SAMPLE ONLY**

**SAMPLE ONLY**

Super Heat Temp	8-10°F
BTUH Requirements	9,738 BTUH @ 20° F SST
Defrost	6 defrosts per day, 45° F termination, 45 min. failsafe

----- Sample Serial Label For Refrigerated Case -----



888 E. Porter Rd · Muskegon, MI 49441

**Addenda<sup>®</sup>** PC5682 txtRemote  
txtSerialNumber

120 VOLTS 60 HZ SINGLE PHASE 1.84AMP

**FOR PARTS OR SERVICE CALL**  
**STRUCTURAL CONCEPTS**  
**AT**  
**1-800-433-9489**



3048256

CONFORMS TO UL STD 65  
CERTIFIED TO CAN/CSA  
STD C22.2 NO 120

**SAMPLE ONLY**

----- Sample Serial Label For Non-Refrigerated Case -----

# CAREL

## ir33 platform

Integrated Electronic  
Microprocessor Controller



### Programming The Instrument

#### To Modify The Setpoint

**Set** Press and hold the “SET” key for at least 1 second.

**▲/aux** **def/▼** 2. Use arrow keys ▲ ▼ on temperature controller to increase (or decrease) the setpoint.

**Set** 3. Quickly press and release the “SET” key again.

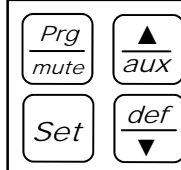

#### To Modify Defrost, Differential, Other Parameters

**Prg/mute** **Set** 1. Press & hold “Prg” & “SET” keys together for five (5) seconds; display will flash “0”, representing password prompt.

**Set** 2. Confirm by pressing “SET” key.

**▲/aux** **def/▼** 3. Press ▲ or ▼ to reach the category to be modified.

**Set** 4. Press “SET” to modify this selected parameter.

**▲/aux** **def/▼** 5. Increase or decrease the value using the ▲ or ▼ button respectively.

**Set** 6. Press the “SET” key to temporarily save the new value and return to the display of the parameter.

**Prg/mute** 7. Press & hold the “Prg” key for at least 5 seconds to save changes. This action will also mute the audible alarm (buzzer) & deactivate the alarm relay.

#### How To Change Reading From Fahrenheit (°F) To Celsius (°C)

**Prg/mute** **Set** 1. Press and hold “Prg” and “SET” keys together for at least 5 seconds; display will show “0” (password prompt).

**Set** 2. Confirm by pressing “SET” key.

**▲/aux** **def/▼** 3. Press ▲ or ▼ until reaching the parameter “/ 5”.

**Set** 4. Press “SET” to modify this selected parameter.

**▲/aux** **def/▼** 5. Press ▲ or ▼ to change value to desired setting: “0” for Celsius (°C) or “1” for Fahrenheit (°F).

**Set** 6. Press “SET” key to temporarily save the new value and return to the display of the parameter.

**Prg/mute** 7. Press & hold “Prg” key for at least 5 seconds to save changes. **Note! All values will automatically convert to new scale. No conversion is required.**

#### Warning! Save Your Parameter Settings!

1. To store the new parameter values, PRESS and HOLD the “Prg” key for at least 5 seconds.
2. All modifications made to parameters will be lost if you do NOT press a button within 60 seconds. Should this “timeout” occur, normal operational settings (prior to modifications being made) will resume.
3. If the instrument is switched off before pressing the “Prg” key, all modifications to parameters will be lost.

**def/▼** **To Activate Manual Defrost**  
Press and hold “def” key for at least 5 seconds.

**▲/aux** **To Activate / Deactivate Auxiliary Output**  
Press and hold the “aux” key for 1 second.

**Prg/mute** **▲/aux** **To Reset Any Alarms With Manual Reset**  
Press and hold the “Prg” and “aux” key for at least 1 second.

# CAREL

**ir33 platform**  
**Integrated Electronic  
 Microprocessor Controller**



## User Interface - Display

ICON	FUNCTION	DESCRIPTION	Normal operation			Start up
			ON	OFF	BLINK	
	COMPRESSOR	ON when the compressor starts. Flashes when the activation of the compressor is delayed by safety times.	Compressor on	Compressor off	awaiting activation	
	FAN	ON when the fan starts. Flashes when the activation of the fan is prevented due to external disabling or procedures in progress.	Fan on	Fan off	awaiting activation	
	DEFROST	ON when the defrost is activated. Flashes when the activation of the defrost is prevented due to external disabling or procedures in progress.	Defrost in progress	Defrost not in progress	awaiting activation	
	AUX	Flashes if the anti-sweat heater function is active, ON when the auxiliary output (1 and/or 2) selected as AUX (or LIGHT in firmware version 3.6) is activated.	AUX auxiliary output active (version 3.6 light auxiliary output active)	AUX auxiliary output not active	Anti-sweat heater function active	
	ALARM	ON following pre-activation of the delayed external digital input alarm. Flashes in the event of alarms during normal operation (e.g. high/low temperature) or in the event of alarms from an immediate or delayed external digital input.	Delayed external alarm (before the time 'A7' elapses)	No alarm present	Alarms in norm. operation (e.g. High/low temperature) or immediate or delayed alarm from external digital input	
	CLOCK	ON if at least one timed defrost has been set. At start-up, comes ON for a few seconds to indicate that the Real Time Clock is fitted.	If at least 1 timed defrost event has been set	No timed defrost event set	Alarm clock	ON if real-time clock present
	LIGHT	Flashes if the anti-sweat heater function is active, ON when the auxiliary output (1 and/or 2) selected as LIGHT is activated (in firmware version 3.6 it does not flash in anti-sweat heater mode and comes on when the dead band output is active).	Light auxiliary output on (version 3.6 dead band auxiliary output active)	Light auxiliary output off	Anti-sweat heater function active (version 3.6 does not flash in anti-sweat heater mode)	
	SERVICE	Flashes in the event of malfunctions, for example E2PROM errors or probe faults.		No malfunction	Malfunction (e.g. E2PROM error or probe fault). Contact service	
	CONTINUOUS CYCLE	ON when the CONTINUOUS CYCLE function is activated. Flashes if the activation of the function is prevented due to external disabling or procedures in progress (E.g.: minimum compressor OFF time).	CONTINUOUS CYCLE operation activated	CONTINUOUS CYCLE function not activated	CONTINUOUS CYCLE operation requested	

## Summary Table of Alarm and Signals: Display, Buzzer and Relay

Code	Icon on the display	Alarm relay	Buzzer	Reset	Description
rE	flashing	on	on	automatic	virtual control probe fault
E0	flashing	off	off	automatic	room probe S1 fault
E1	flashing	off	off	automatic	defrost probe S2 fault
E2	flashing	off	off	automatic	probe S3 fault
E3	flashing	off	off	automatic	probe S4 fault
E4	flashing	off	off	automatic	probe S5 fault
	No	off	off	automatic	probe not enabled
LO	flashing	on	on	automatic	low temperature alarm
HI	flashing	on	on	automatic	high temperature alarm
AFr	flashing	on	on	manual	antifreeze alarm
IA	flashing	on	on	automatic	immediate alarm from external contact
dA	flashing	on	on	automatic	delayed alarm from external contact
dEF	on	off	off	automatic	defrost running
Ed1	No	off	off	automatic/manual	defrost on evaporator 1 ended by timeout
Ed2	No	off	off	automatic/manual	defrost on evaporator 2 ended by timeout
Pd	flashing	on	on	automatic/manual	maximum pump down time alarm
LP	flashing	on	on	automatic/manual	low pressure alarm
AtS	flashing	on	on	automatic/manual	autostart in pump down
cht	No	off	off	automatic/manual	high condenser temperature pre-alarm
CHT	flashing	on	on	manual	high condenser temperature alarm
dor	flashing	on	on	automatic	door open too long alarm
EE	flashing	off	off	automatic	E2prom error, unit parameters
EF	flashing	off	off	automatic	E2prom error, operating parameters
ccb	Signal				start continuous cycle request
ccE	Signal				end continuous cycle request
dFb	Signal				start defrost call
dFE	Signal				end defrost call
On	Signal				switch ON
off	Signal				switch OFF
rES	Signal				reset alarms w/manual reset / reset HACCP alarms / reset temp. monitoring

# CAREL

## ir33 platform

Integrated Electronic  
Microprocessor Controller



### Summary Table of Operating Parameters

CODE	PARAMETER	UOM*	TYPE	MINIMUM	MAXIMUM	DEFAULT
/5	Select Celsius (°C) or Fahrenheit (°F)	flag	C	0	1	For Case Specific Defaults See Serial Label Located Near Electrical Access On Your Case.  For Additional Technical Information Call Structural Concepts Technical Service Dept. at 1(800) 433.9489
/c1	Calibration of probe 1	°C/°F	C	-20	20	
/c2	Calibration of probe 2	°C/°F	C	-20	20	
St	Temperature set point	°C/°F	F	r2	r1	
rd	Control delta	°C/°F	F	20	0.1	
dl	Interval between defrosts	hours	F	0	250	
dt1	End defrost temperature, evaporator	°C/°F	F	-50	200	
dP1	Maximum defrost duration, evaporator	min	F	1	250	
d6	Display on hold during defrost	-	C	0	2	
dd	Dripping time after defrost	min	F	0	15	
d/1	Display of defrost probe 1	°C/°F	F	-	-	

\* Unit Of Measure

STRUCTURAL CONCEPTS CORPORATION TECHNICAL SERVICE  
PHONE NUMBER: 1.800.433.9489 or For Your Master Service Agent See  
[WWW.STRUCTURALCONCEPTS.COM/Contact/Master\\_Service\\_Agents.asp](http://WWW.STRUCTURALCONCEPTS.COM/Contact/Master_Service_Agents.asp)

# LIMITED WARRANTY

All sales by Structural Concepts Corporation (SCC) are subject to the following limited warranty. "Goods" refers to the product or products being sold by SCC.

**Warranty Scope:** Warranty is for equipment sold in the United States, Canada, Mexico and Puerto Rico. Equipment sold elsewhere may carry modified warranty.

**Warranty; Remedies; Limitations.** SCC warrants that if any Goods are found by an authorized representative of SCC not to be of good material or workmanship within one year of the date of shipments SCC will, at its option after inspection by an authorized representative, replace any defective Good or pay the reasonable cost of replacement for any such defective Goods, provided that written notice of the defect is given to SCC within 30 days of the appearance of such defect. If notice is not given within such period, any claim for breach of warranty shall be conclusively deemed to have been waived and SCC shall not be liable under this warranty. If SCC is unable to repair or replace the defective Goods, SCC shall issue a credit to the Purchaser for all or part of the purchase price, as SCC shall determine. The replacement or payment in the manner described above shall be the sole and exclusive remedy of Purchaser for a breach of this warranty. If any Goods are defective or fail to conform to this warranty, SCC will furnish instructions for their disposition. No Goods shall be returned to SCC without its prior consent.

SCC's liability for any defect in the Goods shall not exceed the purchase price of the Goods. SCC SHALL HAVE NO LIABILITY TO PURCHASE FOR CONSEQUENTIAL DAMAGES OF ANY KIND WHATSOEVER, INCLUDING, BUT NOT LIMITED TO, PERSONAL INJURY, PROPERTY DAMAGE, LOST PROFITS, OR OTHER ECONOMIC INJURY DUE TO ANY DEFECT IN THE GOODS OR ANY BREACH OF SCC, SCC SHALL NOT BE LIABLE TO THE PURCHASER IN TORT FOR ANY NEGLIGENT DESIGN OR MANUFACTURE OF THE GOODS, OR FOR THE OMISSION OF ANY WARNING THEREFROM.

SCC shall have no obligation or liability under this warranty for claims arising from any other party's (including Purchaser's) negligence or misuse of the Goods or environmental conditions. This warranty does not apply to any claim or damage arising for or cause by improper storage, handling, installation, maintenance, or from fire, flood, accidents, structural defects, building settlement or movement, acts of God, or other causes beyond SCC's control.

Except as expressly stated herein, SCC makes no warranty, express, implied, statutory or otherwise as to any parts or goods not manufactured by SCC. SCC shall warrant such parts or Goods only (I) against such defects, (II) for such periods of time, and (III) with such remedies, as are expressly warranted by the manufacturer of such parts of Goods. Notwithstanding the foregoing, any warranty with respect to such parts of Goods and any remedies available as a result of a breach thereof shall be subject to all of the procedures, limitations, and exclusions set forth herein.

THE WARRANTIES HEREIN ARE IN LIEU OF ALL WARRANTIES, EXPRESS, IMPLIED, STATUTORY, OR OTHERWISE. IN PARTICULAR, SCC MAKES NO WARRANTY OF MERCHANTABILITY OR FITNESS FOR A PARTICULAR PURPOSE.

No representative, agent or dealer of SCC has authority to modify, expand, or extend this Warranty, to waive any of the limitations or exclusions, or to make any different or additional warranties with respect to Goods.

**Period of Limitations.** No claim, suit or other proceeding may be brought by Purchaser for any breach of the foregoing warranty or this Agreement by SCC or in any way arising out of this Agreement or relating to the Goods after one year from the date of the breach. In the interpretation of this limitation on action for a breach by SCC, it is expressly agreed that there are no warranties of future performance of the goods that would extend that period of limitation herein contained for bringing an action.

**Indemnifications.** Purchaser agrees to indemnify, hold harmless, and defend SCC if so requested, from any and all liabilities, as defined herein, suffered, or incurred by SCC as a result of, or in connection with, any act, omission, or use of the Goods by Purchaser, its employees or customers, or any breach of this Agreement by Purchaser. Liabilities shall include all costs, claims, damages, judgments, and expenses (including reasonable attorney fees and costs).

**Remedies of SCC.** SCC's rights and remedies shall be cumulative and may be exercised from time to time. In a proceeding or action relating to the breach of this Agreement by Purchaser, Purchaser shall reimburse SCC for reasonable costs and attorney's fees incurred by SCC. No waiver by SCC of any breach of Purchaser shall be effective unless in writing nor operate as a waiver of any other breach of the same term thereafter. SCC shall not lose any right because it has not exercised it in the past.

**Applicable Law.** This Agreement is made in Michigan and shall be governed by and interpreted according to Michigan law. Any lawsuit arising out of this Agreement or the Goods may be handled by a federal or state court whose district includes Muskegon County, Michigan, and Purchaser consents that such court shall have personal jurisdiction over Purchaser.

**Miscellaneous.** If any provision of this Agreement is found to be invalid or unenforceable under any law, the provision shall be ineffective to that extent and for the duration of the illegality, but the remaining provisions shall be unaffected. Purchaser shall not assign any of its rights nor delegate any of its obligations under this Agreement without prior written of SCC. This Agreement shall be binding upon and inure to the benefit of SCC and Purchaser and each of their legal representatives, successors and assigns.

SCC warrants its products to be free of defects in materials and workmanship under normal use and service for a period of one (1) year from the date of delivery.

This warranty is extended only to the original purchaser for use of the Goods. It does not cover normal wear parts such as plastic tongs, tong holders, tong cables, bag holders, or acrylic dividers.

**General Conditions.** All service labor and/or parts charges are subject to approval by SCC. Contact the Customer Service Department in writing or call 231-798-8888.

All claims must contain the following information: (1) model & serial code number of equipment; (2) the date and place of installation; (3) the name and address of the agency which performed the installation; (4) the date of the equipment failure; and (5) a complete description of the equipment failure and all circumstances relating to that failure.

Once the claim has been determined to be a true warranty claim by SCC's Customer Service Department, the following procedure will be taken: (1) replacement parts will be sent at no charge from SCC on a freight prepaid basis; (2) reimbursement for service labor will be paid if the following conditions have been met - (a) prior approval of service agency was awarded from the Customer Service Department; and (b) an itemized statement of all labor charges incurred is received by the Customer Service Department. The cost of the service labor reimbursement will be based on straight time rates and reasonable time for the repair of the defect.

If problems occur with any compressor, notify SCC's Customer Service Department immediately. Any attempt to repair or alter the unit without prior consent from the Customer Service Department will render any warranty claim null and void. This warranty and protection plan does not apply to any condensing unit or any part thereof which has been subject to accident, negligence, misuse, or abuse, or which has not been operated in accordance with the manufacturer's recommendations or if the serial number of the unit has been altered, defaced, or removed.

**Limit of Liability.** The limit of liability of SCC toward the exchange cost of the original condensing unit, F.O.B. SCC, Norton Shores, MI, of each motor-compressor assembly replaced during the warranty shall not exceed manufacturer's current established wholesaler's exchange price and in no case shall the labor of removing or replacing the motor-compressor or parts thereof be the responsibility of SCC.