

STAR[®]
THERMAL VECTION
Heat and Hold Drawer

MODEL
TVD30, TVD50

**Installation and
Operation
Instructions**

2M-Z14279 Rev. A 7/16/13

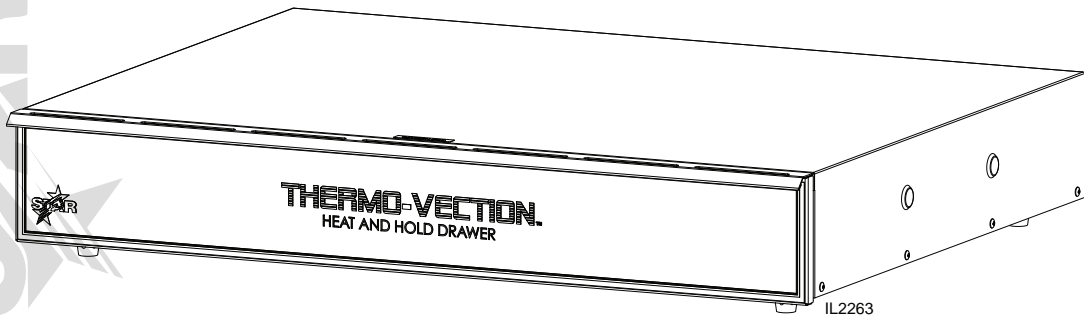

SAFETY SYMBOL



These symbols are intended to alert the user to the presence of important operating and maintenance instructions in the manual accompanying the appliance.

RETAIN THIS MANUAL FOR FUTURE REFERENCE NOTICE

Using any part other than genuine Star factory supplied parts relieves the manufacturer of all liability.

Star reserves the right to change specifications and product design without notice. Such revisions do not entitle the buyer to corresponding changes, improvements, additions or replacements for previously purchased equipment.

Due to periodic changes in designs, methods, procedures, policies and regulations, the specifications contained in this sheet are subject to change without notice. While Star International Holdings Inc., Company exercises good faith efforts to provide information that is accurate, we are not responsible for errors or omissions in information provided or conclusions reached as a result of using the specifications. By using the information provided, the user assumes all risks in connection with such use.

MAINTENANCE AND REPAIRS

Contact your local authorized service agent for service or required maintenance.

Please record the model number, serial number, voltage and purchase date in the area below and have it ready when you call to ensure a faster service.

Model No. _____
Serial No. _____
Voltage _____
Purchase Date _____

Authorized Service Agent Listing

Reference the listing provided with the unit

or

for an updated listing go to:

Website: www.star-mfg.com
E-mail Service@star-mfg.com

Service Help Desk

Business Hours: 8:00 am to 4:30 p.m. Central Standard Time

Telephone: (314) 678-6303

Fax: (314) 781-2714

E-mail Parts@star-mfg.com
Service@star-mfg.com
Warranty@star-mfg.com

Website: www.star-mfg.com

Mailing Address: Star International Holdings Inc., Company
10 Sunnen Drive
St. Louis, MO 63143
U.S.A

SPECIFICATIONS

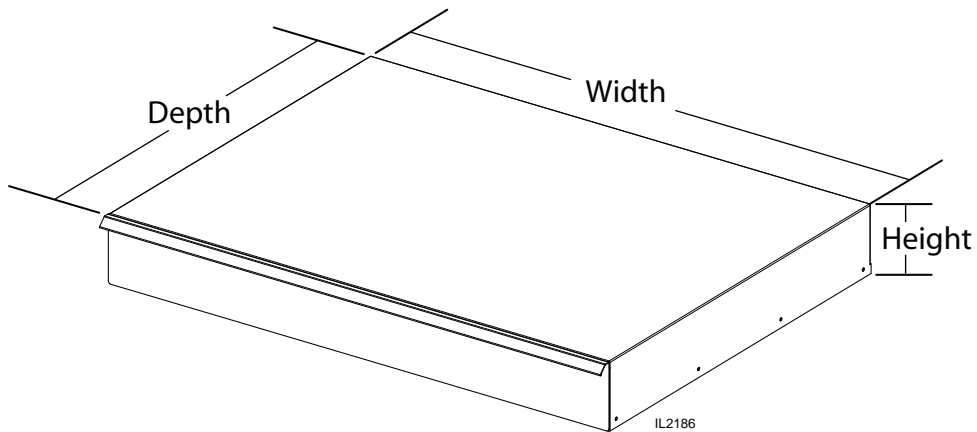

Electrical Specifications				
Model	Voltage	Watts	Amps	Cord
TD30	120V	700	5.8A	NEMA 5-15P
TD50		1370	11.4A	
Dimensions				
	Width	Depth	Height	
TD30	24"	29.75"	6.25"	
TD50	36"			



CAUTION

This equipment is designed and sold for commercial use only by personnel trained and experienced in its operation and is not sold for consumer use in and around the home nor for use directly by the general public in food service locations.

VOLTAGE

The thermal vection is equipped for use on the voltage specified on the nameplate.



WARNING

DO NOT CONNECT TO ANY OTHER TYPE OF CURRENT OR THE MACHINE WILL BE SERIOUSLY DAMAGED.

OPERATION

START-UP

When the unit is first turned on it will begin the PRE-HEAT mode. The current hold temperature will be displayed for 3 seconds, then "PHT" (PREHEAT) will flash along with the "HEAT ON" lamp until the unit has reached its preset hold temperature. When this has been reached, the audible alarm will beep 3 times, the "HEAT ON" lamp will stop flashing and the display will read "RDY".

COOKING

Load the unit with the product, (thawed not frozen) Press the "COOK" button to begin. The "COOK" light will remain on and the Temp light will be on as the unit call for heat. "COOK" will display for 3 seconds, and then the internal cook timer will begin counting down.

Close the drawer.

When the timer reaches 00:00, the audible alarm will beep 3 times.

Then you have two options:

1. Remove the product immediately from the Thermal Vection and place in on your preheated roller grill for display, then press the "RESET" button. This will take the temperature back to the PRE-HEAT mode temperature, until you are ready to cook again.
2. Leave the product in the Thermal Vection until you are ready to serve, the unit will maintain the HOLD temperature and an internal timer will begin to count down, after 3 hours an audible alarm will sound for 3 seconds and the display will flash "DoNE" until the RESET button is pressed. At this time the remaining product left in the unit has expired and needs to be discarded.

READING TEMPERATURE

At any point the operator can view the actual temperature by pressing the "TEMP" button. The reading will be displayed in the temperature mode (°F or °C) which is programmed.

PROGRAMMING THE TEMPERATURE MODE

The temperature mode can be changed from °F to °C or °C to °F by pressing and holding the "TEMP" button while turning on the main power switch. The set-point temperature that is displayed will be in the changed temperature mode.

PROGRAMMING HOLD / PREHEAT TEMPERATURE MODE (F / C)

The HOLD / PREHEAT temperature and hold time can be programmed using the following steps. The default HOLD temp and TIME are 140°F (60°C) for 3 hours.

1. Simultaneously press and hold the "TEMP" and "HOLD" buttons for approx 3 seconds.
2. The display will show "----"
3. Release the buttons.
4. Enter the 4 digit security code. (4,3,2,1)
5. Once completed, the current hold / preheat temperature will be displayed.
6. To increase or decrease the temperature use the "UP" or "DOWN" arrows.
7. Press the "TEMP" button to save the change.
8. The current time duration for the HOLD mode is now displayed.
9. Use the "UP" or "DOWN" arrows to increase or decrease the HOLD time.
10. Press the "TEMP" button to save the new HOLD time.
11. Press the "TEMP" button again to exit the programming mode.

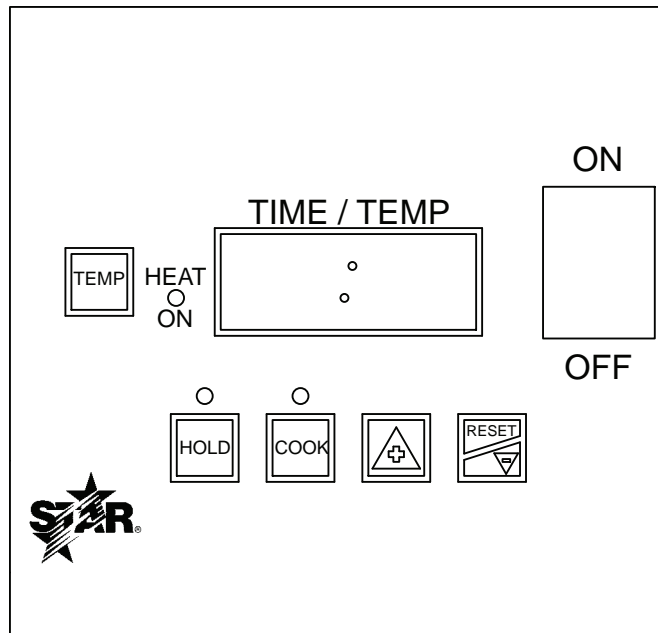

IL2139

PROGRAMMING THE COOK TEMPERATURE MODE

The cook temperature and time can be programmed with the following steps. The unit comes from the factory set at 325°F (163°C) for 30 minutes.

1. Simultaneously press and hold the “TEMP” and “COOK” buttons for approx 3 seconds.
2. The display will show “----“
3. Release the buttons.
4. Enter the 4 digit security code. (4,3,2,1)
5. Once completed, the current COOK temperature will be displayed.
6. To increase or decrease the temperature use the “UP” or “DOWN” arrows.
7. Press the “TEMP” button to save the change.
8. The current time duration for the COOK mode is now displayed.
9. Use the “UP” or “DOWN” arrows to increase or decrease the COOK time.
10. Press the “TEMP” button to save the new COOK time.
11. Press the “TEMP” button again to exit the programming mode.

CLEANING

Clean the pans & covers with mild soap and water after each use. Wipe the exterior with damp cloth and mild detergent daily.

For retaining the high luster on the stainless steel, use a non-abrasive standard stainless steel cleaner.

MAINTENANCE AND REPAIRS

Contact the factory, a service representative, or a local service company for service or required maintenance.

THOROUGHLY INSPECT YOUR UNIT ON ARRIVAL

This unit has been tested for proper operation before leaving our plant to insure delivery of your unit in perfect condition. However, there are instances in which the unit may be damaged in transit. In the event you discover any type of damage to your product upon receipt, you must immediately contact the transportation company who delivered the item to you and initiate your claim with same. If this procedure is not followed, it may affect the warranty status of the unit.

LIMITED EQUIPMENT WARRANTY

All workmanship and material in Star products have a one (1) year limited warranty on parts & labor in the United States and Canada. Such warranty is limited to the original purchaser only and shall be effective from the date the equipment is placed in service. Star's obligation under this warranty is limited to the repair of defects without charge, by the factory authorized service agency or one of its sub-agencies. Models that are considered portable (*see below*) should be taken to the closest Star service agency, transportation prepaid.

- > Star will not assume any responsibility for loss of revenue.
- > On all shipments outside the United States and Canada, see International Warranty.
- * The warranty period for the JetStar six (6) ounce & Super JetStar eight (8) ounce series popcorn machines is two (2) years.
- * The warranty period for the Chrome-Max Griddles is five (5) years on the griddle surface. See detailed warranty provided with unit.
- * The warranty period for Teflon/Dura-Tec coatings is one year under normal use and reasonable care. This warranty does not apply if damage occurs to Teflon/Dura-Tec coatings from improper cleaning, maintenance, use of metallic utensils, or abrasive cleaners, abrasive pads, product identifiers and point-of-sale attachments, or any other non-food object that comes in continuous contact with the roller coating. This warranty does not apply to the "non-stick" properties of such materials.
- > This warranty does not apply to "Special Products" but to regular catalog items only. Star's warranty on "Special Products" is six (6) months on parts and ninety (90) days on labor.
- > This warranty does not apply to any item that is disassembled or tampered with for any purpose other than repair by a Star Authorized Service Center or the Service Center's sub-agency.
- > This warranty does not apply if damage occurs from improper installation, misuse, wrong voltage, wrong gas or operated contrary to the Installation and Operating instructions.
- > This warranty is not valid on Conveyor Ovens *unless* a "start-up/check-out" has been performed by a Factory Authorized Technician.

PARTS WARRANTY

Parts that are sold to repair out of warranty equipment are warranted for ninety (90) days. The part only is warranted. Labor to replace the part is chargeable to the customer.

SERVICES NOT COVERED BY WARRANTY

1. Travel time and mileage rendered beyond the 50 mile radius limit
2. Mileage and travel time on portable equipment (*see below*)
3. Labor to replace such items that can be replaced easily during a daily cleaning routine, ie; removable kettles on fryers, knobs, grease drawers on griddles, etc.
4. Installation of equipment
5. Damages due to improper installation
6. Damages from abuse or misuse
7. Operated contrary to the Operating and Installation Instructions
8. Cleaning of equipment
9. Seasoning of griddle plates
10. Voltage conversions
11. Gas conversions
12. Pilot light adjustment
13. Miscellaneous adjustments
14. Thermostat calibration and by-pass adjustment
15. Resetting of circuit breakers or safety controls or reset buttons
16. Replacement of bulbs
17. Replacement of fuses
18. Repair of damage created during transit, delivery, & installation OR created by acts of God

PORTABLE EQUIPMENT

Star will not honor service bills that include travel time and mileage charges for servicing any products considered "Portable" including items listed below. These products should be taken to the Service Agency for repair:

- * The Model 510FD Fryer.
- * The Model 526TOA Toaster Oven.
- * The Model J4R, 4 oz. Popcorn Machine.
- * The Model 518CMA & 526CMA Cheese Melter.
- * The Model 12MC & 15MC & 18MCP Hot Food Merchandisers.
- * The Model 12NCPW & 15NCPW Nacho Chip/Popcorn Warmer.
- * All Hot Dog Equipment **except Roller Grills & Drawer Bun Warmers.**
- * All Nacho Cheese Warmers **except Model 11WLA Series Nacho Cheese Warmer.**
- * All Condiment Dispensers **except the Model HPD & SPD Series Dispenser.**
- * All Specialty Food Warmers **except Model 130R, 11RW Series, and 11WSA Series.**
- * All QCS/RCS Series Toasters **except Model QCS3 & RCS3 Series.**
- * All Fast Steamer Models **except Direct Connect Series.**

ALL:

- * Pop-Up Toasters
- * Butter Dispensers
- * Pretzel Merchandisers
(Model 16PD-A Only)
- * Pastry Display Cabinets
- * Nacho Chip Merchandisers
- * Accessories of any kind
- * Sneeze Guards
- * Pizza Ovens
(Model PO12 Only)
- * Heat Lamps
- * Pumps-Manual

The foregoing warranty is in lieu of any and all other warranties expressed or implied and constitutes the entire warranty.

FOR ASSISTANCE

Should you need any assistance regarding the Operation or Maintenance of any Star equipment; write, phone, fax or email our Service Department. In all correspondence mention the Model number and the Serial number of your unit, and the voltage or type of gas you are using.

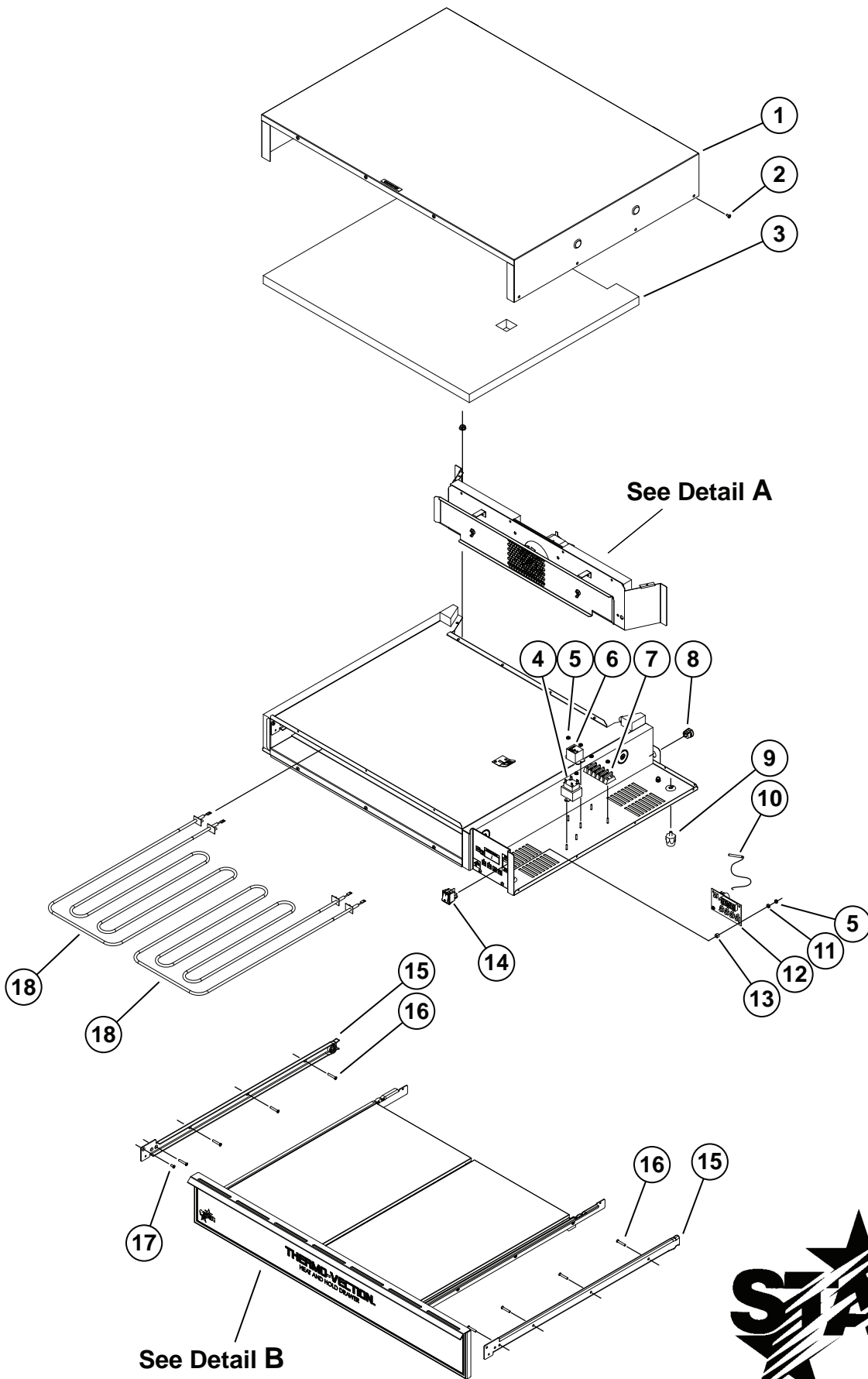

MODEL: TVD THERMAL VECTOR
MAIN BREAKDOWN

STAR MANUFACTURING INTERNATIONAL, INC.
 SK2514 Rev. - 5/25/11

PARTS LIST

July 16, 2013, Rev. A

Model: TVD THERMAL VECTION				
Fig No.	Part Number	Quantity	Description	Application
1	A4-TVD016	1	ASM-BODY COVER	TVD30-120
	A4-TVD015			TVD50-120
2	2C-6349	23	SCREW #8X3/8 B THP STL NP	ALL
3	A4-Z14869	1	INSULATION, TOP-TVD30	TVD30-120
	A4-Z14038		INSULATION, TOP-TVD50	TVD50-120
4	2E-05-07-0351	1	TRANSFORMER 115/10V 6VA	ALL
5	2C-Z2594	10	NUT 6-32 HEX W STL NP	ALL
6	2E-05-07-0352	1	RELAY 30 AMP	ALL
7	2E-Z2894	1	TERMINAL BLOCK (304)	ALL
8	2K-76118	1	STRAIN RELIEF STR HEYCO 1	ALL
9	2A-Z11501	4	FOOT 1" SOLID RUBBER	ALL
10	2E-Z1470	1	SENSOR-RTD 2000 OHM	ALL
11	2K-08-07-0004	4	SPACER ROUND NYLON	ALL
12	2J-Z13971	1	CONTROL BOARD-SINGLE-TVD	ALL
13	2K-Z1971	4	SPACER .257X.75X.25 NYLON	ALL
14	2E-Z1858	1	SWITCH-LIGHTED	ALL
15	2R-Z14033	1	SLIDES-DWR-650MM-HI TEMP (SET)	ALL
16	2C-Z14859	8	SCREW-8-32X1 PH #100FL SS	ALL
17	2C-34285	10	SCREW 8-32X3/8 PH 100 FL	ALL
18	2N-Z14538	1	ELEMENT-675W-120V-10X18	TVD30-120
		2		TVD50-120
NI	A4-TVD022	1	INSULATION SET-TVD30	TVD30-120
NI	A4-TVD018	1	INSULATION SET-TVD50	TVD50-120
NI	A4-Z14679	1	CORD SET-120V-15A-RING TR	ALL

**IMPORTANT: WHEN ORDERING, SPECIFY VOLTAGE OR TYPE GAS DESIRED
INCLUDE MODEL AND SERIAL NUMBER**

PAGE 1
OF 1

Some items are included for illustrative purposes only and in certain instances may not be available.



Star Manufacturing International, Inc.

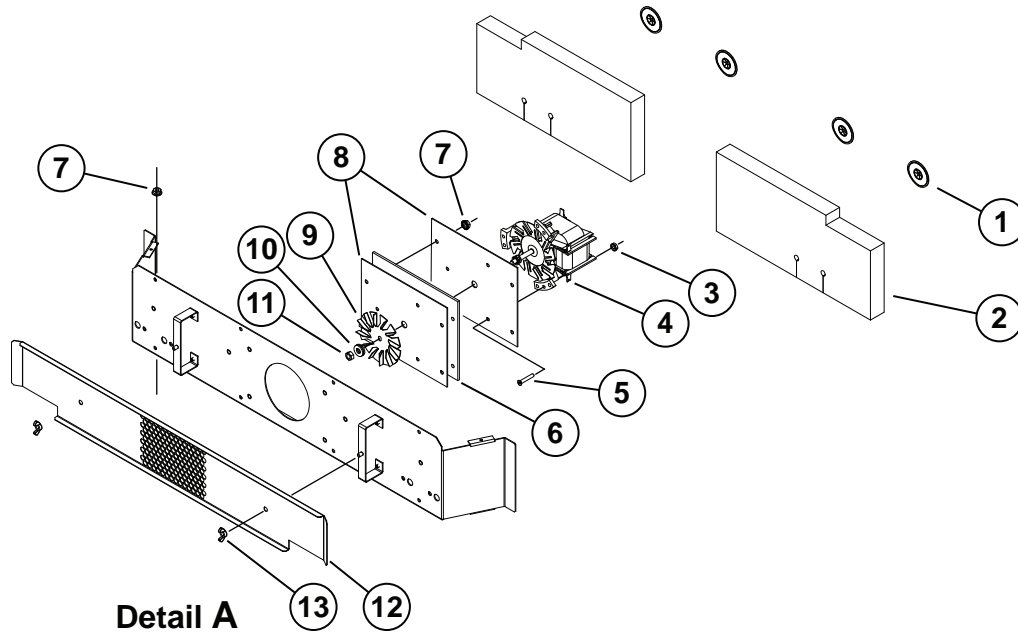

Detail A

Detail B

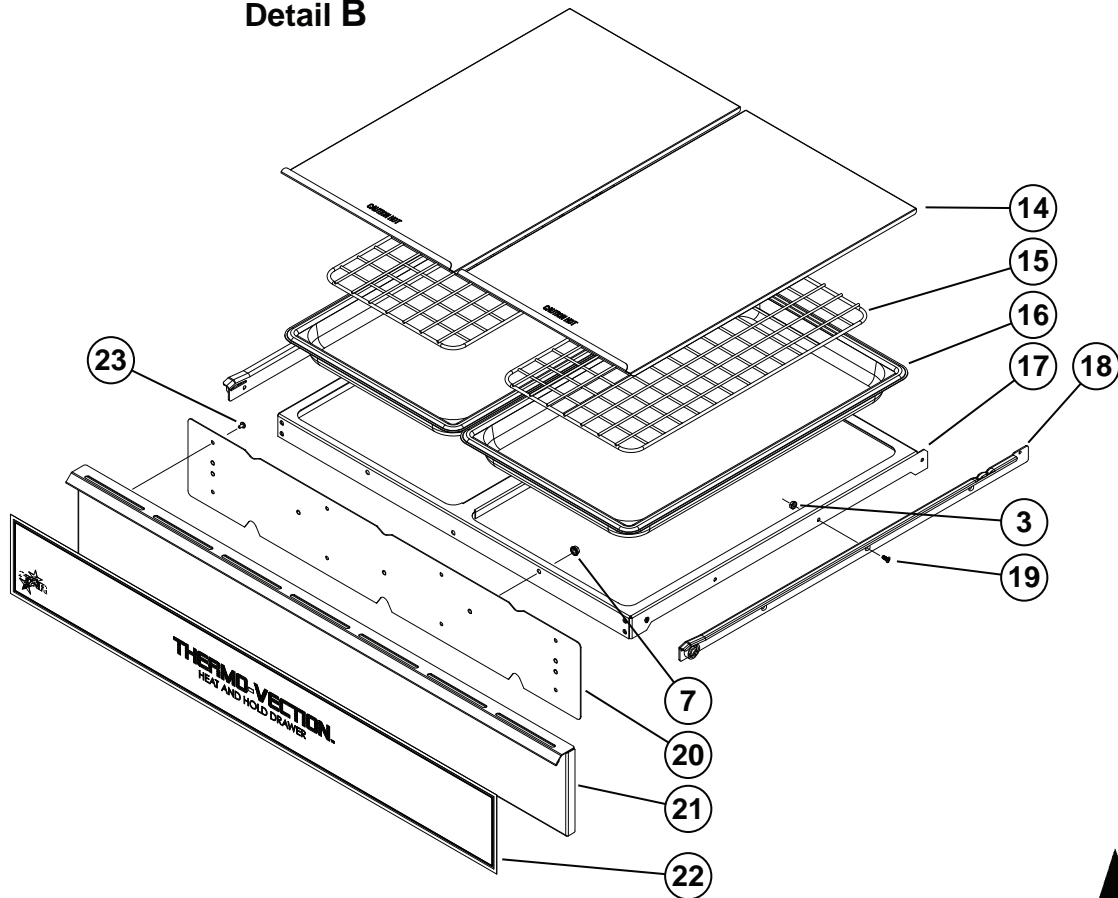

PARTS LIST

July 16, 2013, Rev. A

Model: TVD DETAIL A & B PARTS LIST				
Fig No	Part No	Qty	Description	Application
1	2C-Z14559	8	WASHER-INSULATION 4MM HLE	TVD30-120
		10		TVD50-120
2	A4-Z14871	1	INSULATION-REAR-TVD30 RT	TVD30-120
	A4-Z14872	1	INSULATION-REAR-TVD30 LT	
	A4-Z14040	2	INSULATION-REAR-TVD50	TVD50-120
3	2C-Z3447	19	NUT 8-32 HEX W SS	ALL
4	2U-Z14624	1	MOTOR,FAN-HI TEMP-120V	ALL
5	2C-Z14859	3	SCREW-8-32X1 PH #100FL SS	ALL
6	2H-Z14868	1	INSULATION, MOTOR-MICA	TVD30-120
	2H-Z14413			TVD50-120
7	2C-Z2893	30	NUT 10-24 HEX STL ZP	ALL
8	A4-Z14867	2	PLATE-MOTOR MOUNTING	TVD30-120
	A4-Z14412			TVD50-120
9	2R-Z14035	1	FAN BLADE, 3" CCW, 90 DEG	ALL
10	2C-1811	2	WASHER 1/4 BURR STL NP	ALL
	2C-08-07-0262	1	WASHER, SS 1/4 INT-LOCK	
11	2C-Z14640	1	NUT-M6X1-LH THREADS-SS	ALL
12	A4-Z14423	1	COVER, FAN-TVD50	ALL
13	2C-Z10133	2	NUT, WING 10-24	ALL
14	A4-Z14425	1	LID-SERVING PAN-FULL SIZE	TVD30-120
		2		TVD50-120
15	2B-Z14927	2	FALSE BTM-HALF PAN-WIRE	TVD30-120
	2B-Z16724		FALSE BTM-FULL PAN-WIRE	TVD50-120
16	2D-Z14928	2	PAN, HALF X 1.5" DEEP	TVD30-120
	2D-Z14047		PAN,FULL X 1.5" DEEP	TVD50-120
17	A4-Z14416	1	DRAWER FRAME-TVD30	TVD30-120
	A4-Z14415		DRAWER FRAME-TVD50	TVD50-120
18	2R-Z14033	1	SLIDES-DWR-650MM-HI TEMP (SET)	ALL
19	2C-34285	10	SCREW 8-32X3/8 PH 100 FL	ALL
20	A4-TVD012	1	ASM-DRAWER LINER-TVD30	TVD30-120
	A4-TVD011		ASM-DRAWER LINER-TVD50	TVD50-120
21	A4-TVD014	1	ASM-DRAWER FRONT	TVD30-120
	A4-TVD013			TVD50-120
22	2M-Z14414	1	OVERLAY-DWR FRNT-TVD30	TVD30-120
	2M-Z13862		OVERLAY-DWR FRNT-TVD50	TVD50-120
23	2C-200067	6	SCREW 6-32X1/4 THP SS	TVD30-120
		8		TVD50-120

**IMPORTANT: WHEN ORDERING, SPECIFY VOLTAGE OR TYPE GAS DESIRED
INCLUDE MODEL AND SERIAL NUMBER**

PAGE 1
OF 1

Some items are included for illustrative purposes only and in certain instances may not be available.



Star Manufacturing International, Inc.

STAR INTERNATIONAL HOLDINGS INC. COMPANY
Star - Holman - Lang - Wells - Bloomfield - Toastmaster
10 Sunnen Drive, St. Louis, MO 63143 U.S.A.
(314) 678-6303
www.star-mfg.com