



**OPERATOR'S MANUAL
HOLMAN CONVEYOR TOASTERS
MODELS TH14, TBH14
FOR SERVICE INFORMATION
U.S. AND CANADA CALL: 1-800-264-7827
24 HOURS/DAY 7 DAYS WEEK**

TABLE OF CONTENTS

UNCRATING AND INSPECTION	PAGE 1
ASSEMBLY AND INSTALLATION	PAGE 1, 2
POWER SAVER SWITCH (TH14 ONLY)	PAGE 2
FRONT BEARING ASSEMBLY	PAGE 2a
COOKING PROCEDURES	PAGE 3, 4
CLEANING PROCEDURES	PAGE 5
TROUBLESHOOTING GUIDE	PAGE 6, 7, 8
MAINTENANCE PROCEDURES	PAGE 8, 9,10
PARTS LIST	PAGE 11

LIST OF ILLUSTRATIONS

CRUMB TRAY INSTALLATION	PAGE 1
POWER SAVER/MODE SWITCH	PAGE 2
ADJ. HEAT SHIELD, FRONT VIEW	PAGE 3
COMPONENT ARRANGEMENT	PAGE 7,8
AIR INTAKE VENT	PAGE 5,6
DRIVE SYSTEM	PAGE 7
HEATER TUBE INSTALLATION	PAGE 8
WIRING DIAGRAMS	PAGE 12,13

**OPERATOR'S MANUAL
HOLMAN CONVEYOR TOASTERS
MODELS TH14, TBH14**

UNCRATING AND INSPECTION

Unpack unit and components from container. Remove all visible packing material, inspect unit for damage. If damage is discovered, file a claim immediately with the carrier that handled the shipment.

ASSEMBLY AND INSTALLATION

- A. Attach legs by screwing into weld nuts, as shown.

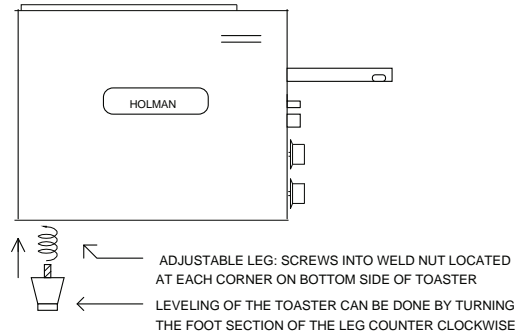

- B. Anti Skid pads are available at no charge and may be adhered to the foot section of each leg to prevent sliding. Call 1-800-264-7827 for details.

WARNING: Use of these pads are not approved by the National Sanitation Foundation.

- C. Be sure the crumb tray and unload chute are properly installed as shown.

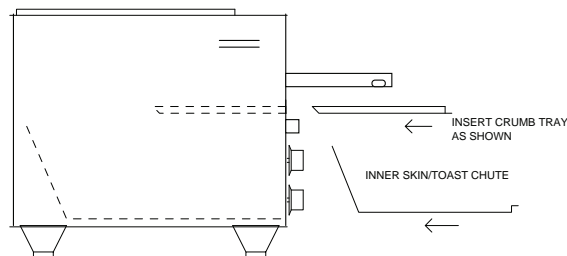

CAUTION- DO NOT OPERATE UNIT WITHOUT CRUMB TRAY PROPERLY POSITIONED.

WARNING: MAKE SURE ALL INPUT POWER IS OFF BEFORE INSTALLING/REMOVING ANY PARTS.

WARNING: BEFORE INSTALLING UNIT(S), CHECK WITH LOCAL POWER COMPANY TO DETERMINE ACTUAL VOLTAGE AT JOB SITE. NEVER PLUG A 208 VOLT UNIT INTO 240 VOLTS OR A 240 VOLT UNIT INTO 208 VOLTS.

WARNING: BE ABSOLUTELY SURE THE GROUND CONNECTION FOR THE RECEPTACLE IS PROPERLY WIRED. NEVER CONNECT UNIT TO POWER WITHOUT PROPER GROUND CONNECTIONS. IMPROPER GROUND MAY RESULT IN SEVERE INJURY OR FATALITY.

**OPERATOR'S MANUAL
HOLMAN CONVEYOR TOASTERS
MODELS TH14, TBH14**

POWER SAVER SWITCH (MODEL TH14 ONLY)

Your Holman toaster (Model TH14 only) is equipped with a Power Saver, details are as follow ;

NEW STYLE

ROTARY POWER SAVER

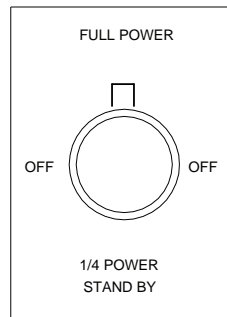

OLD STYLE

TOGGLE POWER SAVER

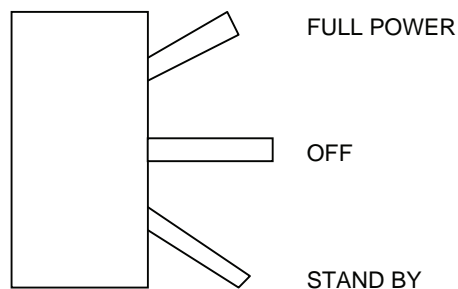

- FULL POWER-** Normal operating position with top and bottom variable heat controls and variable speed conveyor belt control set at appropriate settings.
- OFF- NEW STYLE:** Two off positions are provided so that a single rotation to either direction will result in the unit being turned OFF.
- OFF- OLD STYLE:** The center position of the toggle switch turns the unit completely OFF regardless of heat and speed control settings.
- STANDBY-** 1/4 power standby. To resume toasting, return to full power and make a slight reduction in belt speed. This slower belt speed allows you to start toasting immediately while the unit is returning to full heat. No need to disturb heat settings.

REVISED 2/28/95 MJC

Page 2a

MODELS TH14, TBH14

SPRING LOADED FRONT BEARING ASSEMBLY

Your Holman Conveyor Toaster is equipped with a spring-loaded front bearing assembly as shown below in fig. 1. The spring-loaded bearing assembly keeps the conveyor belt at a constant tension as the unit heats up and cools down. The conveyor belt is set to the proper tension when the white teflon bushing is flush with the end of the extension as shown in fig. 2.

Fig. 1

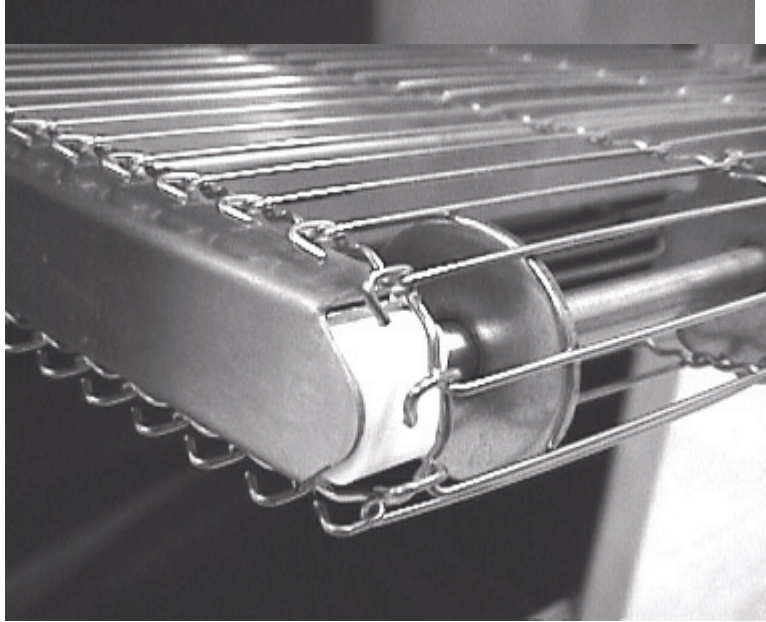

Fig. 2

REVISED 2/5/00 MJC

**OPERATOR'S MANUAL
HOLMAN CONVEYOR TOASTERS
MODELS TH14, TBH14**

COOKING PROCEDURES

A. MODEL TH14, BREAD TOASTING

1. Lower the front heat shield all the way down, leaving just enough clearance for bread slices to pass under the shield into the toasting cavity.

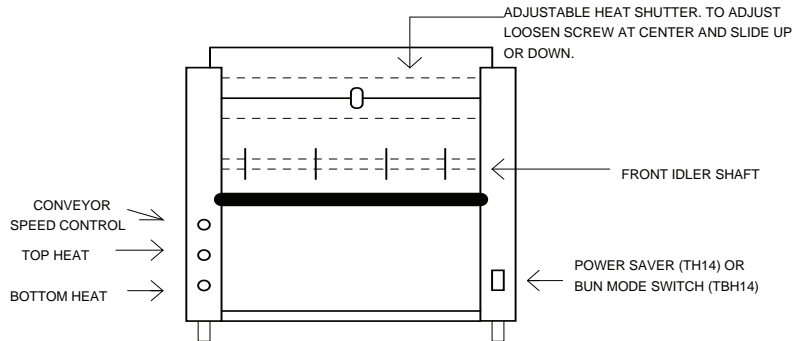

2. Turn top and bottom heat controls to "HI"; turn conveyor speed control to 50.
3. Allow warm up time of 5 to 10 minutes.
4. Test with a slice of bread.
 - a. If toast is too light, turn conveyor speed control counterclockwise.
 - b. If toast is too dark, turn conveyor speed control clockwise.

B. MODEL TBH14, BUN TOASTING AND BREAD TOASTING

The model TBH14 is equipped with a Toast/Bun mode switch and has six heater tubes, four on top and two on bottom.

In the Bun position all four top tubes are energized for bun toasting with no bottom heat.

CAUTION: In bun mode, both top and bottom variable heat controls must be in the "HI" position for all four top tubes to heat, the top heat control regulates the front and rear tubes while the bottom heat control regulates the two center tubes.

**OPERATOR'S MANUAL
HOLMAN CONVEYOR TOASTERS
MODELS TH14, TBH14**

MODEL TBH14, BUN TOASTING CONT.

1. On models TBH14, (mode switch in BUN position) lower the front heat shield as far as possible, leaving just enough clearance for the bun half to pass under and into the toasting cavity.

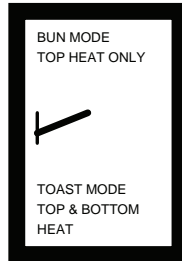

2. Buns will be top toasted only, no bottom heat.
3. Test with a half of a bun.
 - a. If buns are too light, turn conveyor speed control counterclockwise.
 - b. If buns are too dark, turn conveyor speed control clockwise.

MODEL TBH14, BREAD TOASTING

In the Toast position two top tubes and two bottom tubes are energized for bread toasting.

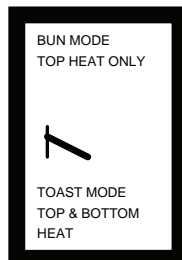

For proper bread toasting instructions refer to Page 3, Par. A

C. DEEP TOASTING OR BAKING (Units with Variable Heat Controls).

Food products that require deep cooking without exterior burning may be cooked by reducing the oven temperature (lowering the top and/or bottom heat controls) and cooking at slower speeds. Some foods may require more top heat than bottom heat or vice versa. Every product will require some experimentation to arrive at the correct balance of heat control and conveyor speed settings.

CAUTION: Each time a setting is changed allow about 5 minutes for the unit to stabilize.

**OPERATOR'S MANUAL
HOLMAN CONVEYOR TOASTERS
MODELS TH14, TBH14**

CLEANING PROCEDURES

1. Turn top and bottom heat controls to the OFF position.
2. For lightly soiled conveyor belts, turn conveyor speed control to fastest setting(100) and wipe with a damp cloth.
3. For heavily soiled conveyors, turn conveyor speed control to fastest setting (100) and wipe with a light abrasive pad.
4. Turn conveyor speed control off.
5. After the unit cools, remove interior crumb tray and clean. Slide crumb tray back into position.

DO NOT OPERATE UNIT WITHOUT CRUMB TRAY IN PLACE AS THIS CAUSES OVERHEATING IN THE CONTROL BOX AND MAY ACTIVATE THE LIMIT SWITCH.

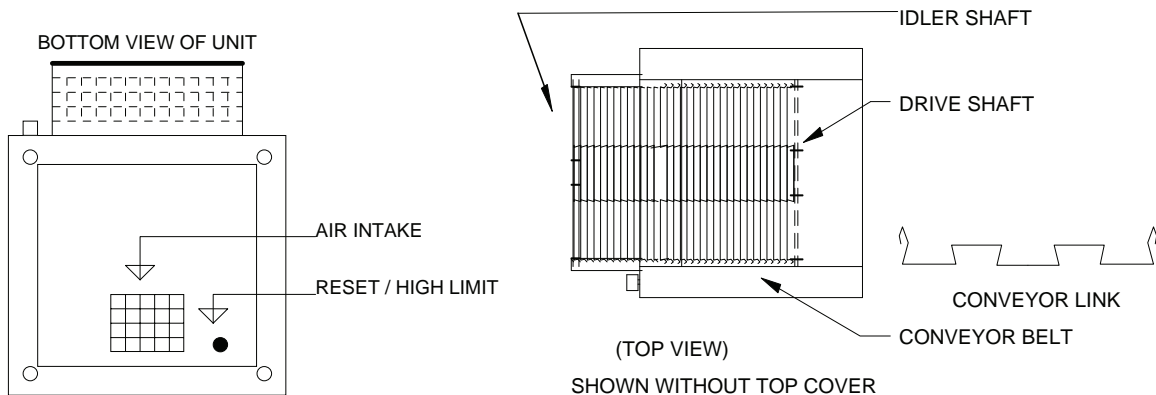

6. Wipe exterior surface of unit.

LUBRICATION OF DRIVE CHAIN WITH A GRAPHITE BASED LUBRICANT IS REQUIRED AS PERIODIC MAINTENANCE. CALL HOLMAN FACTORY SERVICE DEPARTMENT FOR DETAILS.

**OPERATOR'S MANUAL
HOLMAN CONVEYOR TOASTERS
MODELS TH14, TBH14**

TROUBLESHOOTING GUIDE

- A. UNIT WILL NOT HEAT, DRIVE MOTOR WILL NOT RUN.
1. Be sure main circuit breaker is switched to the ON position.
 2. Check to see if toaster is plugged in and all controls turned on.
- B. UNIT WILL NOT HEAT, DRIVE MOTOR RUNS PROPERLY.
1. Check to see if both top and bottom heat control have been turned to HI.
 2. Press heat limit reset button on the bottom of the control box as shown below. If this reactivates the heater tubes, see HEAT LIMIT SWITCH in section C.
- C. HEAT LIMIT SWITCH

Your Holman conveyor toaster is equipped with an automatically activated temperature (heat) limit switch which interrupts the heater tube connections if the air temperature in the control box exceeds 190F (88C). This heat limit switch can be reset manually by pushing the red button at the bottom of the control box.

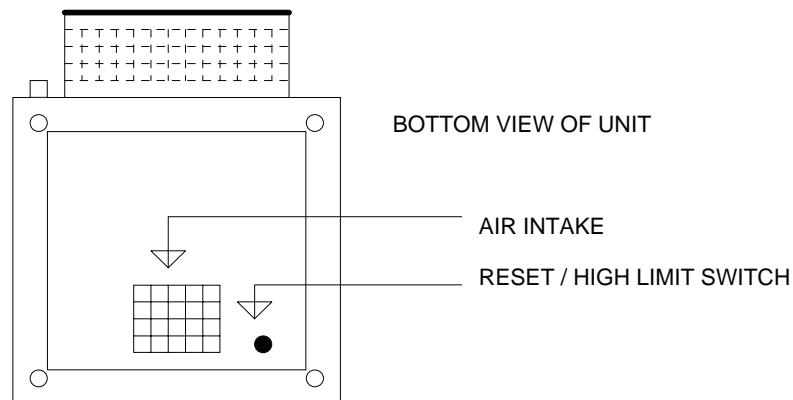

THE HEAT LIMIT SWITCH IS ACTIVATED WHEN THERE IS NOT SUFFICIENT AIR FLOW GENERATED BY THE COOLING FAN. IF THIS SHOULD OCCUR:

1. DISCONNECT UNIT FROM POWER SOURCE.
2. Check to see if air intake vent in the bottom center of the control box is free of dust, grease or other obstructions.
3. Check if crumb tray is in place. NEVER OPERATE UNIT WITHOUT CRUMB TRAY IN PLACE AS THIS CAUSES OVERHEATING IN THE CONTROL BOX.
4. If no obstructions to the air flow can be found and if the crumb tray is in place, call Holman Factory Service Department at 1-800-264-7827 for assistance.

TROUBLESHOOTING GUIDE CONT. ON PAGE 7

**OPERATOR'S MANUAL
HOLMAN CONVEYOR TOASTERS
MODELS TH14, TBH14**

TROUBLESHOOTING GUIDE CONT.

D. CONVEYOR WILL NOT TURN, UNIT HEATS PROPERLY.

1. DISCONNECT UNIT FROM POWER SOURCE.
2. Remove right hand side panel (from operator's position). Remove drive chain from sprocket and motor shaft as shown. Manually move conveyor belt to check for mechanical binding. If conveyor moves freely, call Holman Factory Service Department at 1-800-264-7827 as drive motor and/or speed control may need replacement.

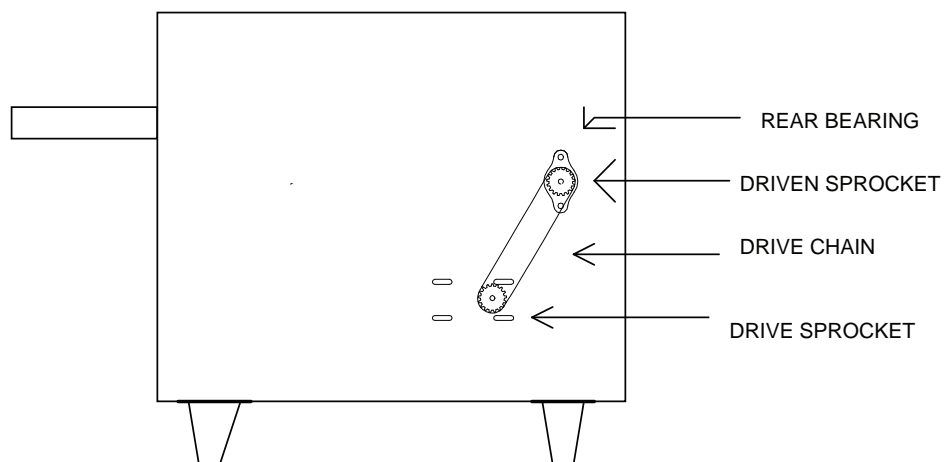
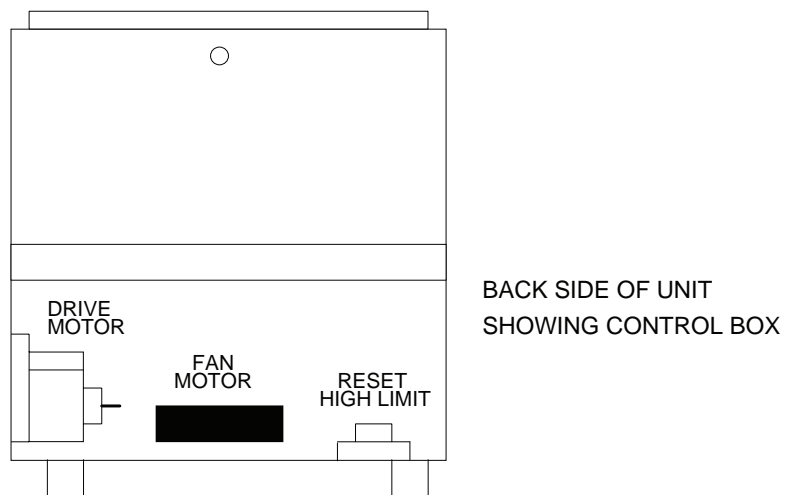

TROUBLESHOOTING GUIDE CONT. ON PAGE 8

REVISED 1/28/97 MJC

**OPERATOR'S MANUAL
HOLMAN CONVEYOR TOASTERS
MODELS TH14, TBH14**

TROUBLESHOOTING GUIDE CONT.

E. CONVEYOR TURNS AT ONE SPEED REGARDLESS OF SPEED CONTROL SETTING.

1. Call Holman Factory Service Department at 1-800-264-7827 as speed control should be replaced.

MAINTENANCE PROCEDURES

A. REPLACING HEATER TUBES (as below)

1. DISCONNECT UNIT FROM POWER SOURCE.
2. Remove right and left side panels.
3. Remove heater tube wire from terminal block connection, keeping top and bottom wires separate.
4. Remove heater tube retainers by removing retaining screws with washer.
5. Gently, pull defective heater tube out of unit.
6. Gently, put new heater tube into unit.
7. Replace heater tube retainers, reconnect heater tube wires to terminal block and install side panels.

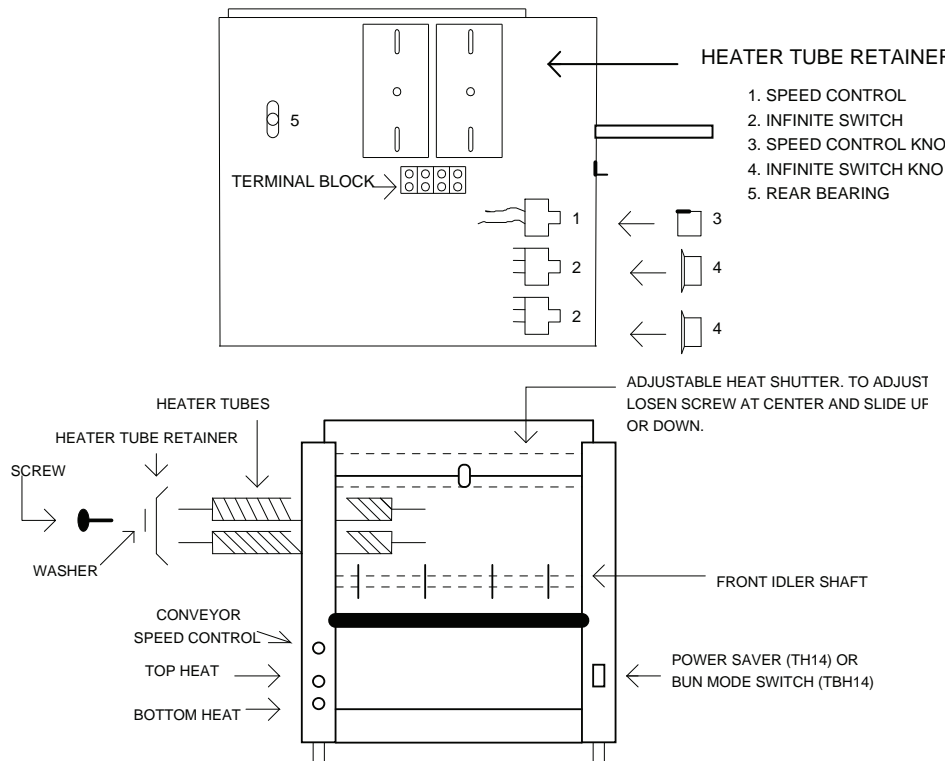

**OPERATOR'S MANUAL
HOLMAN CONVEYOR TOASTERS
MODELS TH14, TBH14**

MAINTENANCE PROCEDURES CONT.

B. REPLACING FAN MOTOR

1. DISCONNECT UNIT FROM POWER SOURCE.
2. Remove control box cover at lower rear of unit.
3. Unplug power supply cord from fan motor.
4. From the underside of unit, remove (4) screws which hold fan motor in place.
5. Put replacement motor in place and secure to the unit with screws.
6. Reconnect power supply cord to fan motor.
7. Replace control box cover.

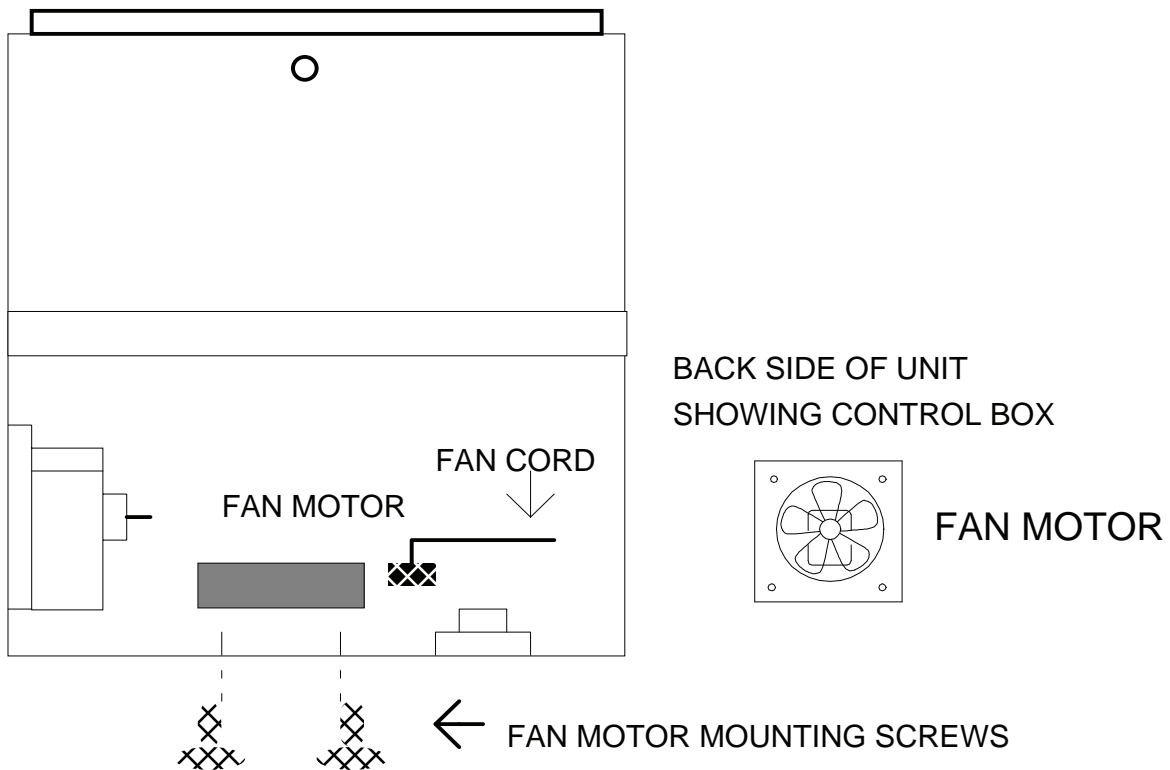

**OPERATOR'S MANUAL
HOLMAN CONVEYOR TOASTERS
MODELS TH14, TBH14**

MAINTENANCE PROCEDURES CONT.

C. REPLACING BELT DRIVE MOTOR

1. DISCONNECT UNIT FROM POWER SOURCE.
2. Remove right side panel and lower control box cover.
3. Remove sprocket from motor shaft.
4. Remove the wire from terminal block connecting the drive motor to internal wiring. On units rated 208 or 240 volts, note which color leads are being used for these connections and which lead is capped with white tape. The new motor should use the same arrangement.
5. Remove screws holding motor in place.
6. Put new motor in place and attach loosely with mounting screws.
7. Replace sprocket on motor shaft.
8. Slide motor until the drive chain has about 1/8" slack when lightly pushed at the center of its top open run.
9. Tighten screws to secure motor.
10. Rewire leads same as removed in step 4.
11. Replace side panel and control box cover.

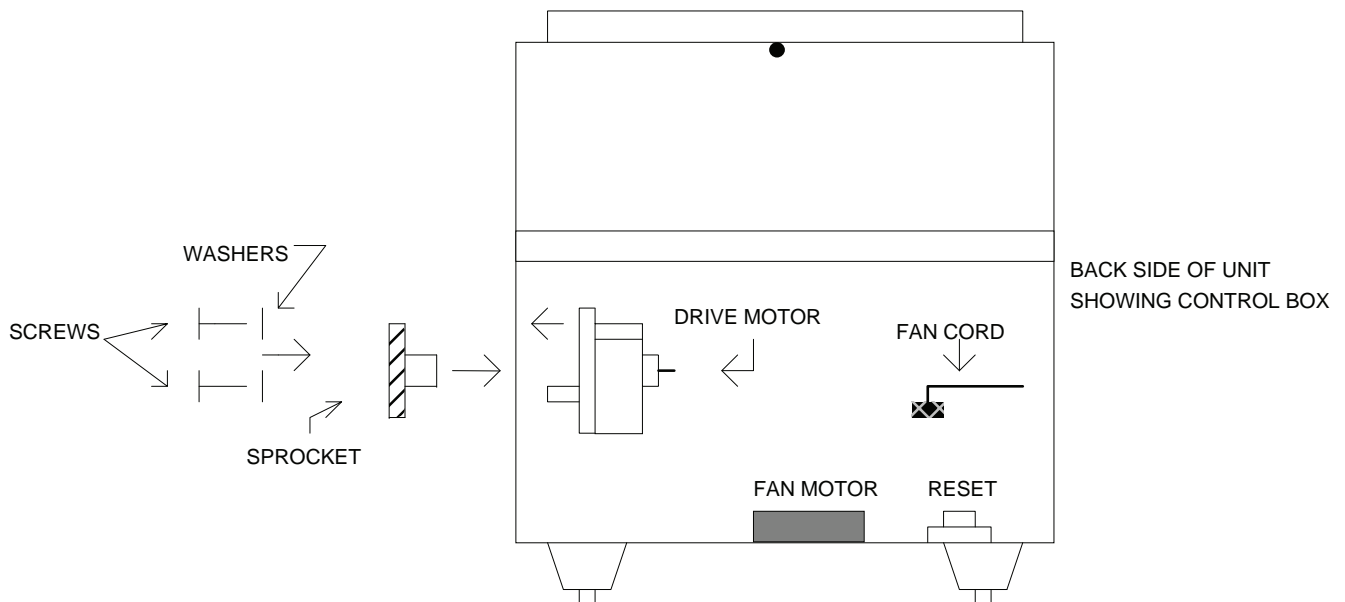

IF ASSISTANCE IS REQUIRED FOR THIS OR ANY OTHER PROCEDURE IN THIS MANUAL CALL HOLMAN FACTORY SERVICE DEPARTMENT AT 1-800-264-7827 24 HOURS/DAY 7 DAYS/WEEK.

HOLMAN CONVEYOR TOASTERS MODELS TH14, TBH14

WIRE DIAGRAM

MODEL TH14

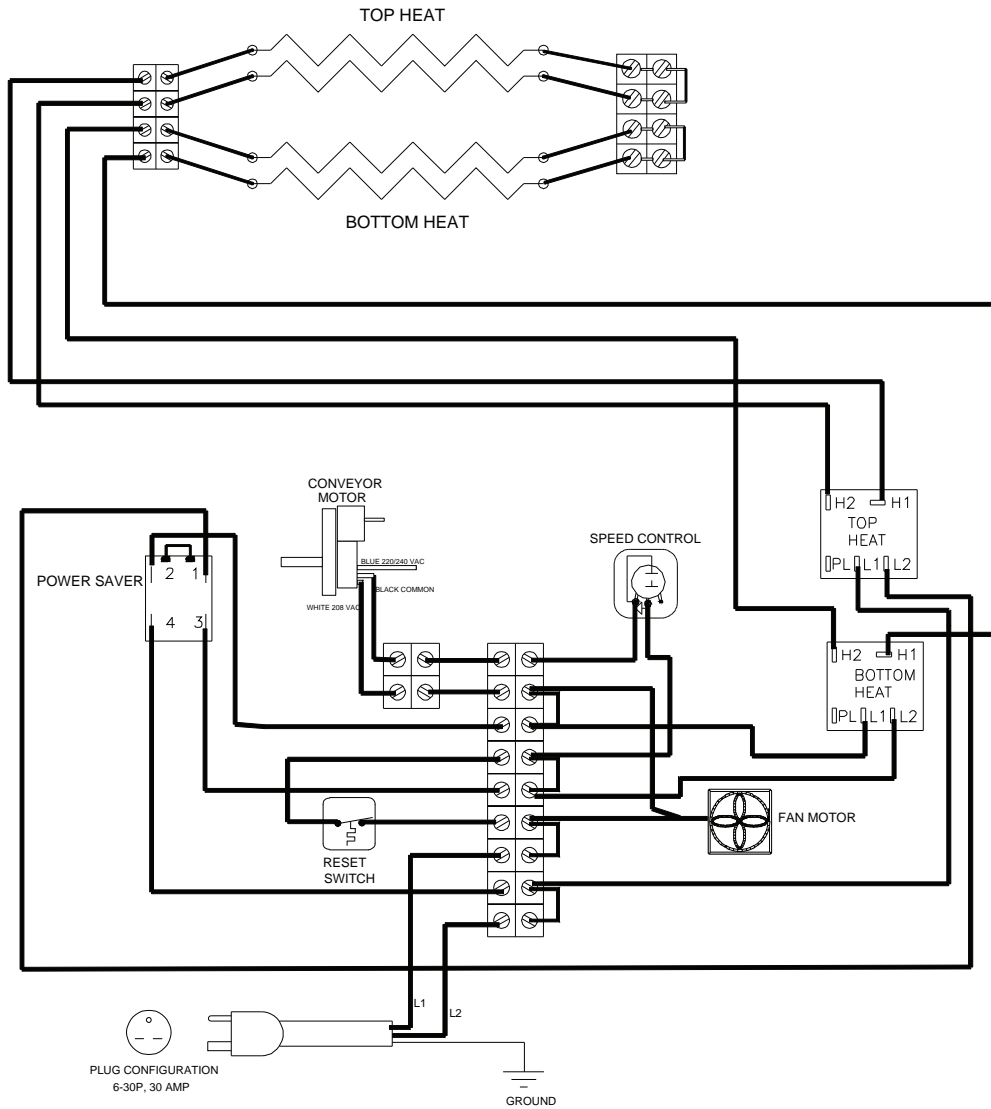

REV. 4/2/99 MJC

OPERATOR'S MANUAL
HOLMAN CONVEYOR TOASTERS
MODEL TBH14

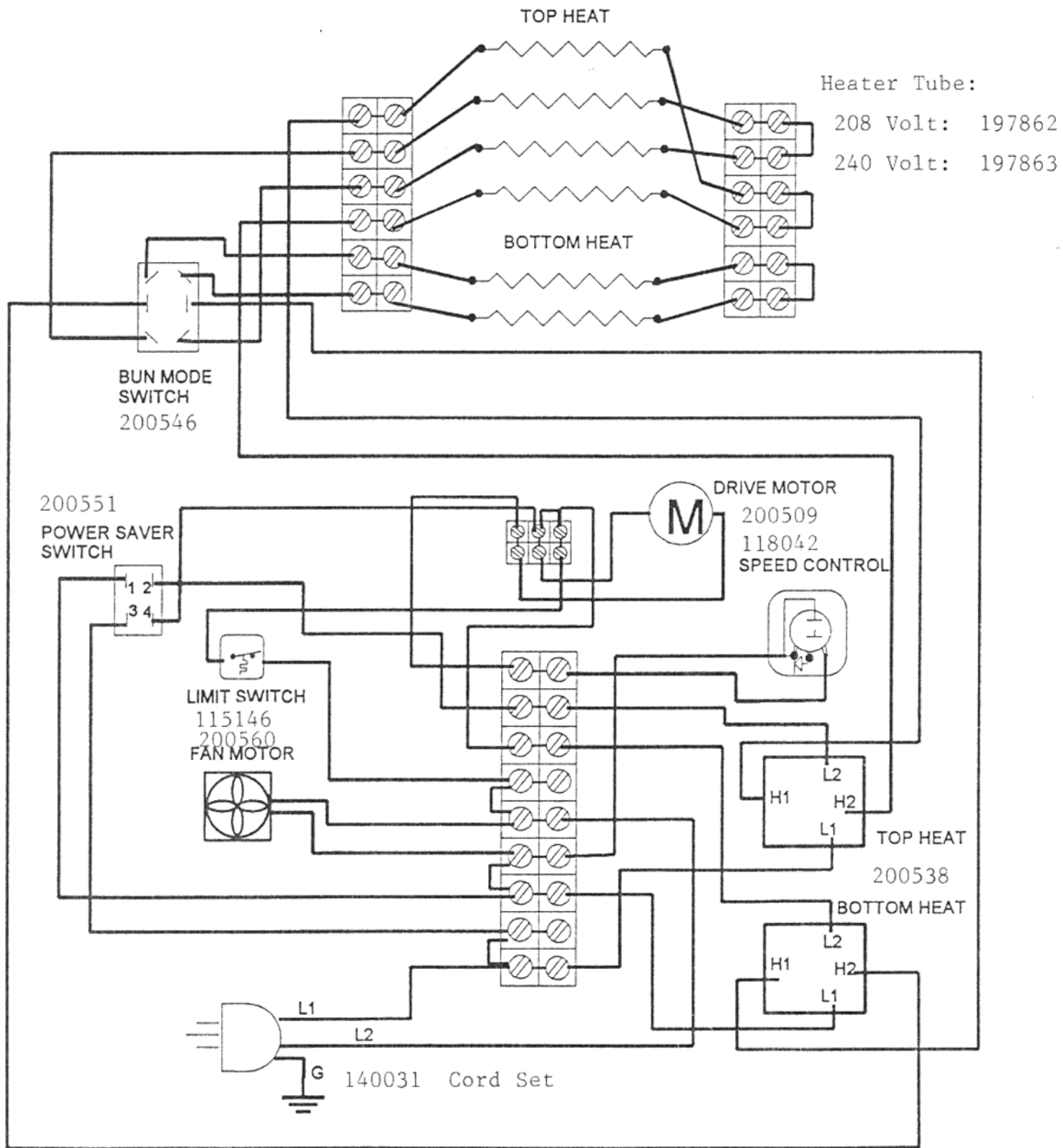

*NOTE: 6 ea. Heater Tubes In Models TBH14 and TH14NY.

07/06/11 BBE

REV. ~~2/7/00 MJC~~

**OPERATOR'S MANUAL
HOLMAN CONVEYOR TOASTERS
MODELS TH14, TBH14**

WIRE DIAGRAM : TBH14

HL-197862= 208V
HL-197863 = 240V

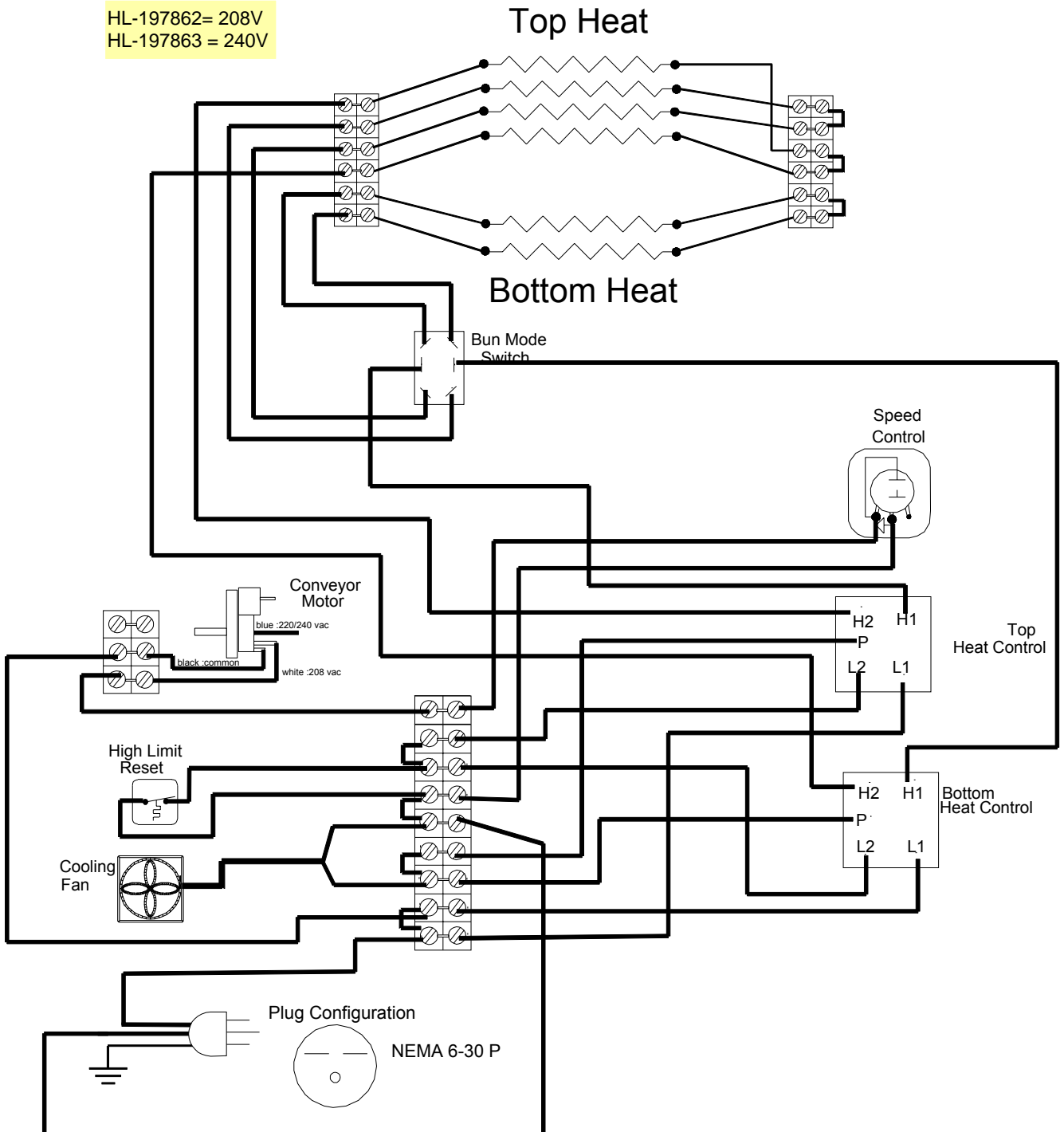

OPERATOR'S MANUAL HOLMAN CONVEYOR TOASTERS
MODELS TH14, TBH14

PARTS LIST

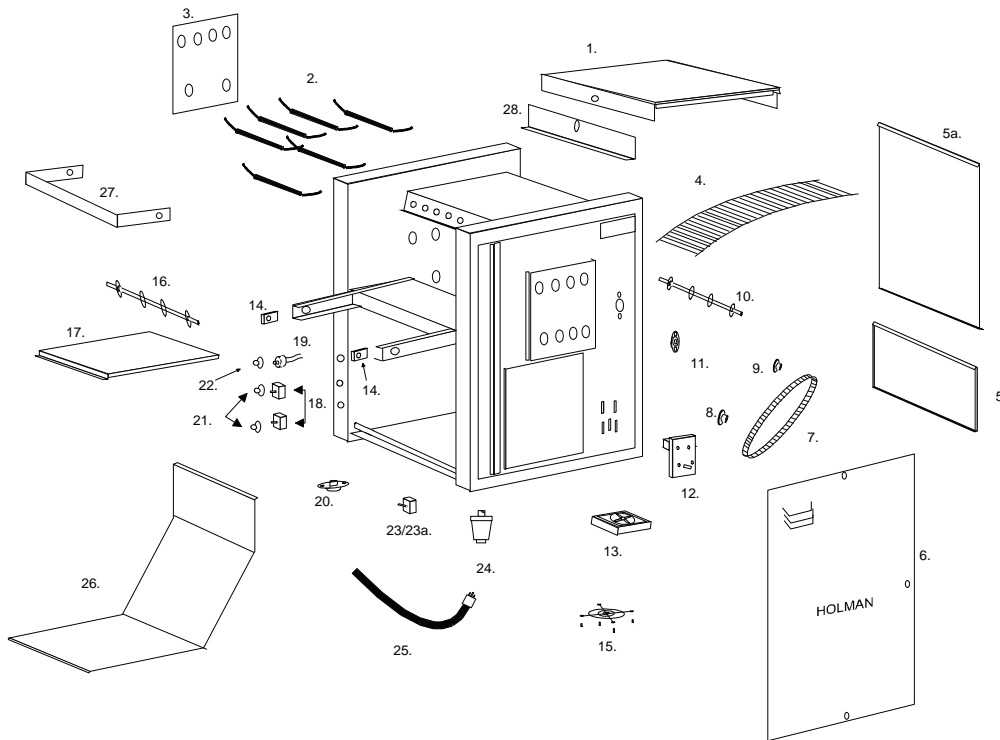

Model: TH14 & TBH14, Conveyor Toaster			
Fig No.	Part No.	Qty	Description
1	GC-400847	1	Top Cover
2	HL-197863	4	Heater Tube, 240 Volt
2 a	HT-197852	4	Heater Tube, 220 Volt
	HT-197851	4	Heater Tube, 208 Volt (Parallel)
2 b	HL-197862	4	Heater Tube, 208 Volt (Series) 907W@104V
	HT-197845	4	Heater Tube, 208 Volt (Series) 807W@104V
3	HW-400967	2	Retainer, Heater Tube
4	HM-160004	1	Conveyor Belt
5	HW-400931	1	Back Panel, Lower
5 a	HW-400930	1	Back Panel, Upper
6	HW-401382	1	Side Panel, Left
6 a	HW-400979	1	Side Panel, Right
7	2P-150013	1	Drive Chain
8	2P-200645	1	Drive Sprocket
9	2P-200645	1	Driven Sprocket
10	HT-100902	1	Drive Shaft
11	HA-112261	1	Bearings
12	2U-200509	1	Drive Motor, 60Hz
12 a	2U-200590	1	Drive Motor, 50Hz

13	2U-200560	1	Fan Motor
14	2P-200700	1	Idler Bushing
15	2R-200562	1	Fan Grill
16	GB-100905	1	Idler Shaft
17	HO-100508	1	Crumb Tray
18	2J-200538	2	Infinite Switch
19	SP-118042	1	Speed Control
20	2E-200566	1	Reset Switch
21	2R-200702	2	Knob, Infinite Switch
22	2R-200703	1	Knob, Speed Control
23	2E-115142	1	Power Saver Switch, Toggle
	2E-200511	1	Power Saver Switch, Rotary
23 a	2E-200546	1	Bun Mode Switch (TBH14)
24	2R-200709	4	Leg, 1" Plastic
25	2E-200374	1	Cord/Plug Set, 12/3, 6-30
26	HW-400919	1	Toast Chute
27	HM-401089	1	Nose Gaurd
28	HM-400899	1	Heat Shutter
29	2P-200736	2	Spring, (not shown)
NI	2M-200841	1	Label, Bun Mode
	2M-200806	1	Label, Control Box

*NOTE: 6 ea. Heater Tubes In Models TBH14 and TH14NY.

[HL-197862](#) = 208V / [HL-197863](#) = 240V

REV. ~~4/4/2011~~ RMS

07/06/11 BBE

STAR INTERNATIONAL HOLDINGS INC. COMPANY
Star - Holman - Lang - Wells - Bloomfield - Toastmaster
10 Sunnen Drive, St. Louis, MO 63143 U.S.A.
(314) 781-2777
www.star-mfg.com