



SANDWICH GRILLS

MODEL
Aluminum

TG14-AS, TG14-AG,

Iron

TG14-IS, TG14-IG

Installation and Operation Instructions

2M-Z19329 Rev. - 12/10/2014

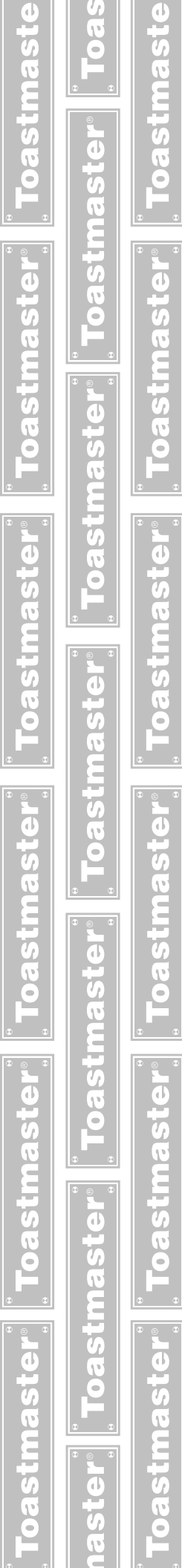
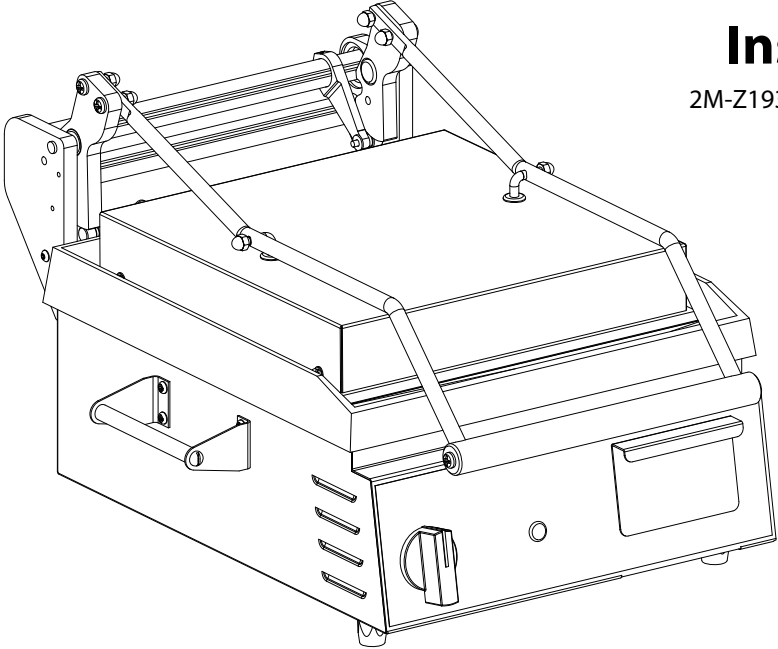

SAFETY SYMBOLS



These symbols are intended to alert the user to the presence of important operating and maintenance instructions in the manual accompanying the appliance.



RETAIN THIS MANUAL FOR FUTURE REFERENCE NOTICE

Using any part other than genuine Toastmaster factory supplied parts relieves the manufacturer of all liability.

Toastmaster reserves the right to change specifications and product design without notice. Such revisions do not entitle the buyer to corresponding changes, improvements, additions or replacements for previously purchased equipment.

Due to periodic changes in designs, methods, procedures, policies and regulations, the specifications contained in this sheet are subject to change without notice. While Toastmaster exercises good faith efforts to provide information that is accurate, we are not responsible for errors or omissions in information provided or conclusions reached as a result of using the specifications. By using the information provided, the user assumes all risks in connection with such use.

MAINTENANCE AND REPAIRS

Contact your local authorized service agent for service or required maintenance.

Please record the model number, serial number, voltage and purchase date in the area below and have it ready when you call to ensure a faster service.

Model No. _____

Serial No. _____

Voltage _____

Purchase Date _____

Authorized Service Agent Listing

Reference the listing provided with the unit

OR

for an updated listing go to:

Website: www.toastmastercorp.com
E-mail Service@star-mfg.com
Telephone: (314) 678-6347

The Service Help Desk

Business Hours: 8:00 am to 4:30 p.m. Central Standard Time

Telephone: (314) 678-6347

Fax: (314) 781-2714

E-mail Parts@star-mfg.com
Service@star-mfg.com
Warranty@star-mfg.com

Website: www.star-mfg.com

Mailing Address: Toastmaster
10 Sunnen Drive
St. Louis, MO 63143
U.S.A

SPECIFICATIONS

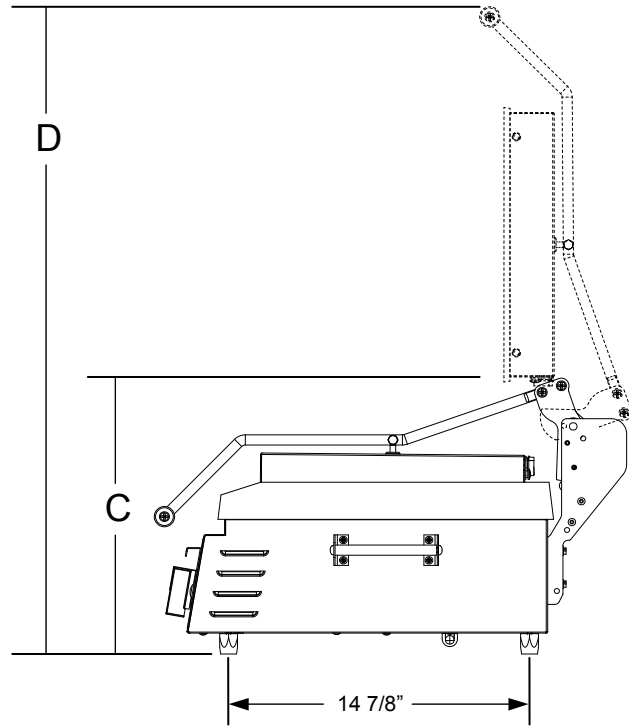
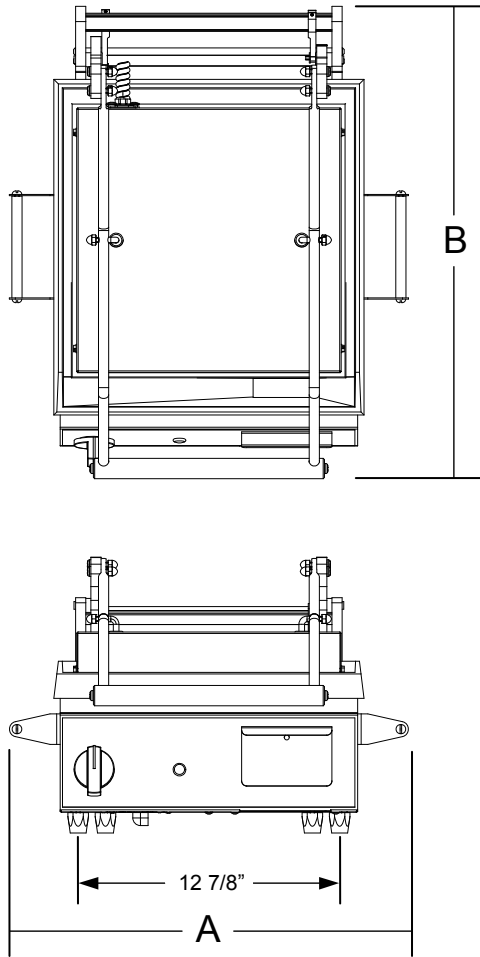

IL2908

2M-Z19329 Toastmaster TG14 Sandwich Grills

SPECIFICATIONS

Model No.	Grid Surface	"A" Width	"B" Depth	Height		Voltage	Wattage	Amps	NEMA	Approx. Weight	
				"C" Closed	"D" Open					Shipping	Installed
TG14	Alum.	19-5/8"	24-5/8"	14-1/4"	33"	120V	1800	15	5-15P	67 lbs. (30.4 kg)	55 lbs (24.9 kg)
		49.8 cm	62.5 cm	36.2 cm	83.2 cm	120C			5-20P		
	Iron	19-5/8"	24-5/8"	17-1/4"	36"	240V	3600	15	6-15P	101 lbs.	87 lbs.
		49.8 cm	62.5 cm	43.8 cm	91.4 cm				6-20P	45.9 kg	39.4 kg

Note: For Canada, 120 volt units listed above have NEMA 5-20P plug and 12/3 gage cord.

FEATURES & BENEFITS

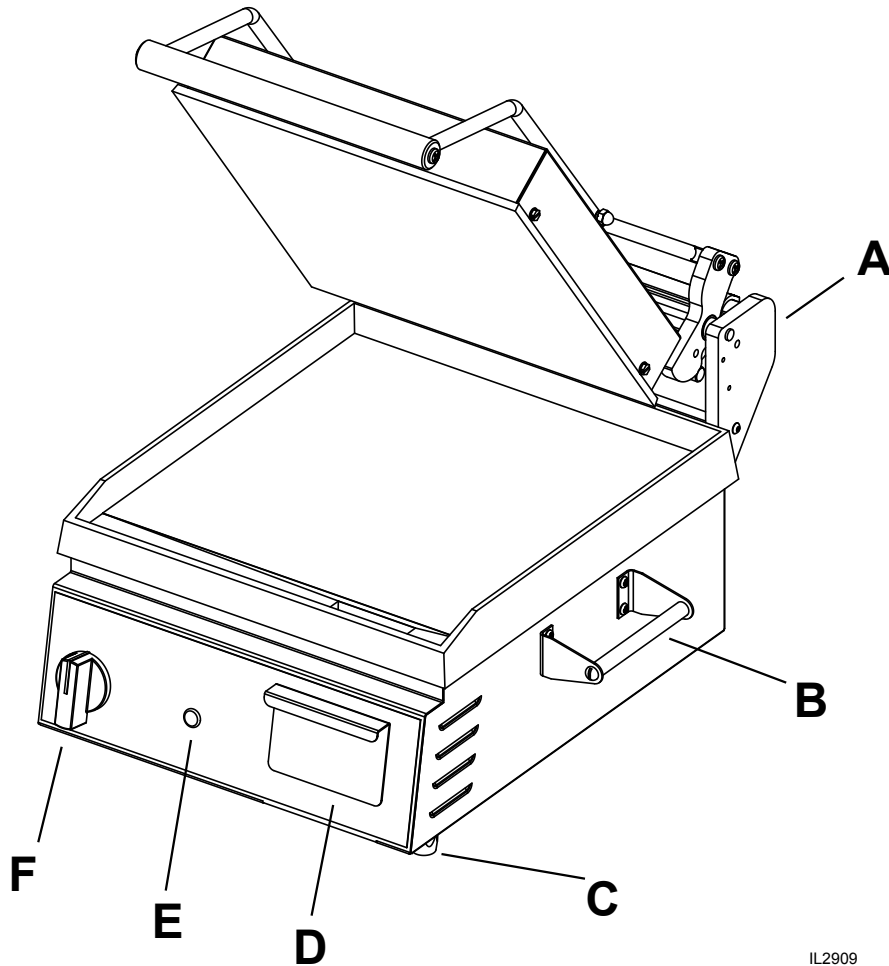

IL2909

A	Counter Balance	Heavy duty counter balance hinge system provides safe and effortless operation of the top platen.
B	Side Handles	Allows for easy moving of the unit for cleaning underneath. It also prevents items from being placed directly up against the cooking surface.
C	Non-Skid Feet	Prevents the unit from moving
D	Debris Drawer	Catches debris that gets left behind on the cooking surface.
E	Pilot Light	Turns 'ON' when the element calls for heat
F	Temperature Knob	Turns unit ON & OFF. The temperature can be set between 175°F to 550°F.

GENERAL INSTALLATION DATA



This equipment is designed and sold for commercial use only by personnel trained and experienced in its operation and is not sold for consumer use in and around the home nor for use directly by the general public in food service locations.

Before using your new equipment, read and understand all the instructions & labels associated with the unit prior to putting it into operation. Make sure all people associated with its use understand the units operation & safety before they use the unit.

All shipping containers should be checked for freight damage both visible and concealed. This unit has been tested and carefully packaged to insure delivery of your unit in perfect condition. If equipment is received in damaged condition, either apparent or concealed, a claim must be made with the delivering carrier.

Concealed damage or loss - if damage or loss is not apparent until after equipment is unpacked, a request for inspection of concealed damage must be made with carrier within 15 days. Be certain to retain all contents plus external and internal packaging materials for inspection. The carrier will make an inspection and will supply necessary claim forms.

VENTILATION AND CLEARANCES

The installation of any components such as a vent hood, grease extractors, and/or fire extinguishing systems, must conform to their applicable nationally recognized installation standards and/or local building codes.



ELECTRICAL CONNECTION

Before making any electrical connection be sure to read data plate which is located at the bottom of the unit.

ELECTRICAL GROUNDING INSTRUCTIONS

This unit is equipped with a 3-prong (grounding) plug for your protection against shock hazard and must be plugged directly into a properly grounded 3-prong receptacle.



DO NOT CUT OR REMOVE THIS PLUG OR GROUNDING PRONG FROM THE PLUG.

CONNECT/PLUG UNIT INTO DEDICATED A.C LINE ONLY SPECIFIED ON THE DATA PLATE OF THE UNIT.

OPERATION

Level unit using the adjustable feet under the unit (approximately 1/2" adjustment).

Before using the unit for the first time, clean and heat for approximately 30 minutes. The grill may emit a small amount of smoke as the cooking surfaces reach 300-350°F (148-176°C). Do not be alarmed, as the smoke is caused by oils associated with the manufacturing process and will stop when the grill reaches 400°F (204°C).

SEASONING THE COOKING SURFACES (NON CHROME SURFACES)

FIRST TIME SEASONING

Follow your company/corporate guidelines for seasoning cooking surfaces. or

1. Bring the grill to 300°F (148°C) and leave it on while doing the next three steps.
2. Brush the cooking surfaces with a salt free liquid vegetable oil. If using an aerosol agent, first apply into a cup and then brush onto cooking surface.
3. Let sit for 20 minutes, and then wipe clean using a warm damp cloth.

DAILY SEASONING

The grill should not require much seasoning while in use. In most cases, brush a light coating of a **salt free** liquid vegetable oil in the morning and occasionally throughout the day will be enough to prevent any sticking. It is not necessary to apply before grilling each item.

SETTING THE TEMPERATURE

The thermostat control knob is used to set the temperature to your requirements. The maximum set point is 550°F (288°C), the minimum set point is 175°F (79°C). See Knob Settings.

KNOB SETTING

<u>Knob Position</u>	<u>Approx. Temp</u>
1-2	175°F / 79°C
3	200°F / 93°C
4	250°F / 121°C
5	300°F / 148°C
6	350°F / 176°C
7	400°F / 204°C
8	450°F / 232°C
9	500°F / 260°C
10	550°F / 287°C

DAILY OPERATION

Always allow 10-20 minutes of preheat time before loading the unit with product. Failure to allow sufficient preheat time will result in unsatisfactory cooking of the first load. Check the power cord to insure that it is plugged into a proper outlet.

Check that the thermostat control are turned on.

Set the thermostat control knob to desired temperature.

OPERATING HINTS AND SAFETY

Disconnect power to the unit with the switch at the end of each day of operation.

Do not leave the unit in operation without an attendant.

Turn thermostat down to 200°F (93°C) during idle periods. It will take only a few minutes to regain operating temperature.

Use spatula to push excess grease into grease drawer after each load of food is cooked. This will reduce smoking of hot grease and carbonizing.

Do not leave the unit at high temperature when not in use or during idle periods. This will cause food particles and grease film to carbonize.

"Season" cooking surfaces with non-salted vegetable oil to reduce product sticking.

MONTHLY LUBRICATION/INSPECTION

Apply two (2) drops of non-toxic mineral or vegetable oil to counter balance shoulder rivets and plastic spacers.

Check and clean brass rollers to make sure they are rolling and not sliding on the cam surfaces of the counterbalance.

Check the bolts, screws and nuts, tighten if necessary.

CLEANING

Begin cleaning procedure by using the operating procedures within your organization, or follow the steps below:

1. If particles adhere to the cooking surface during the day, scrape them off with a spatula.

NOTE: It is best not to let food cook onto the grill, as food build-up on the grill will increase sticking and smoking. In addition, carbon may build up on the grill surface and reduce the cooking efficiency.

CARBON BUILDUP: *A black matter that forms on or near the cooking surface. Generally this is a combination of: releasing agents, oils, food particles etc. that has cooked itself to the surface. After a period of time without cleaning, this will reduce performance and material may start flaking off. When that happens, follow the "Carbon Cleaning" procedures.*

2. At the end of the day, wipe down all surfaces with a warm, damp cloth and mild detergent, then dry.

CARBON CLEANING

When carbon build up occurs, use a carbon removal agent according to the instructions provided with the cleaner. When this process is complete, you must re-season the grill according to your company/corporate guidelines, or the seasoning instructions in this manual.



DO NOT IMMERSE OR LET THE UNIT STAND IN WATER.

DO NOT HOSE DOWN THE UNIT OR THE TABLE/COUNTER IF THE UNIT IS ON THE TABLE/COUNTER.

KEEP AWAY FROM RUNNING WATER.

DO NOT USE SHARP OBJECTS TO REMOVE CARBON BUILD-UP.

BEFORE CLEANING MAKE SURE POWER IS TURNED OFF, UNIT IS UNPLUGGED AND IS NOT TOO HOT.

While holding top lid with one hand, apply only cleaners which are safe for aluminum and iron surfaces. Wipe with clean sponge or towel until unit is clean.

DO NOT SPLASH FRONT CONTROL PANEL!

DO NOT SPLASH FLEX CONDUIT CONNECTING TOP AND BOTTOM OF THE UNIT.

Remove and empty to clean grease catcher drawer as required using mild detergent and water.



Do not use ice or cold water to clean the cooking surfaces when the unit is hot. The surfaces are cast aluminum or cast iron and may crack or deform under the shock of rapid temperature change.

OPERATION TROUBLESHOOTING

1. Unit not heating.
 - A. Check if unit is plugged in correct receptacle.
 - B. Check incoming power line.
 - C. Check that thermostat is set to proper temperature.
2. Top platen not heating.
 - A. Check that the rocker switch is in correct position.
3. Counter balance roller not rolling.
 - A. Clean rollers.

If unit still does not operate contact the factory or one of its representatives or a local service company for service or required maintenance.

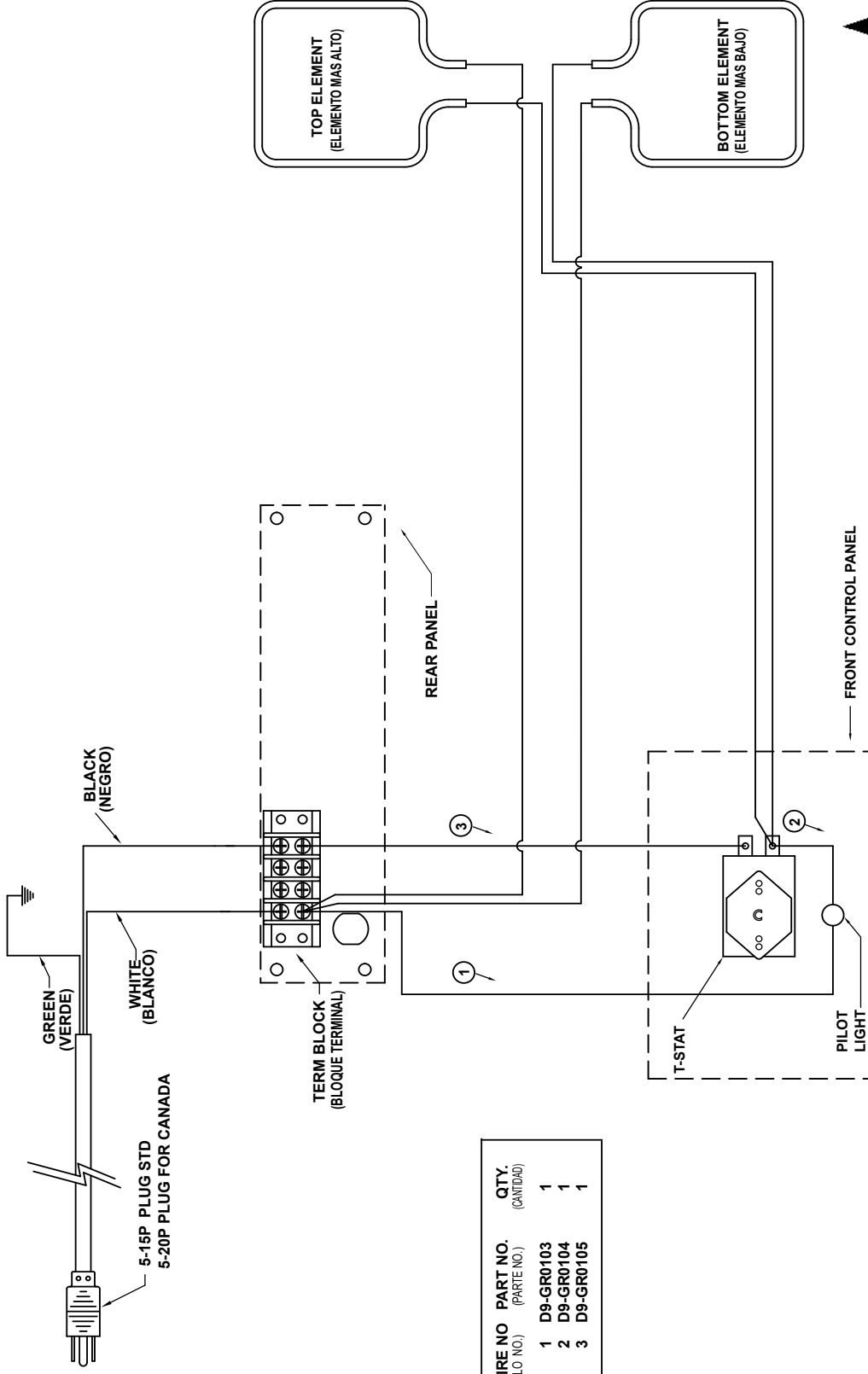

WIRE NO. (HILO NO.)	PART NO. (PARTE NO.)	QTY. (CANTIDAD)
1	D9-GR0103	1
2	D9-GR0104	1
3	D9-GR0105	1

MODEL: GR/CG101-120V, GR/CG141-120V

THIS DRAWING CONTAINS INFORMATION CONFIDENTIAL TO STAR MFG. INT'L. INC.
NO REPRODUCTION OR DISCLOSURE OF ITS CONTENTS IS PERMITTED.



STAR MANUFACTURING INTERNATIONAL INC.

SK1706

Rev A

6/13/2005

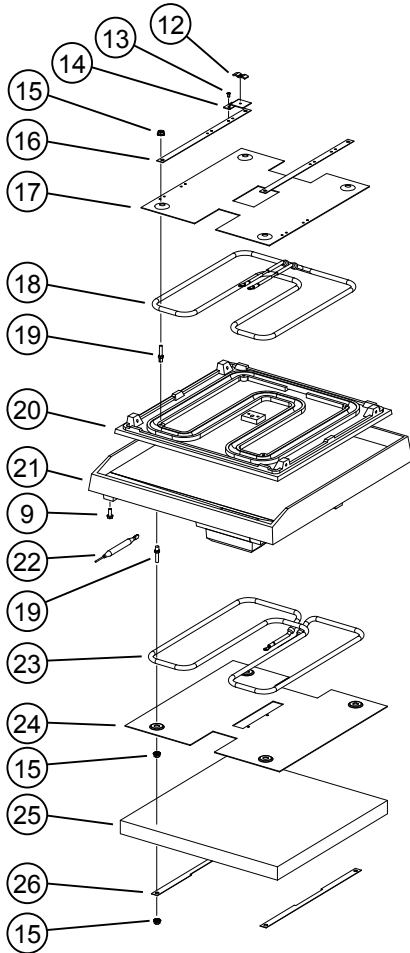
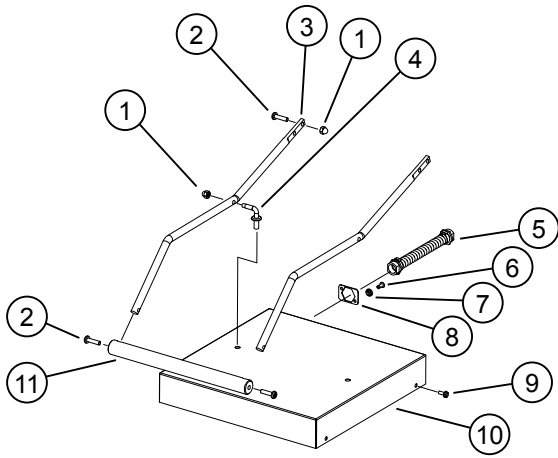

Some items are included for illustrative purposes only and in certain instances may not be available.

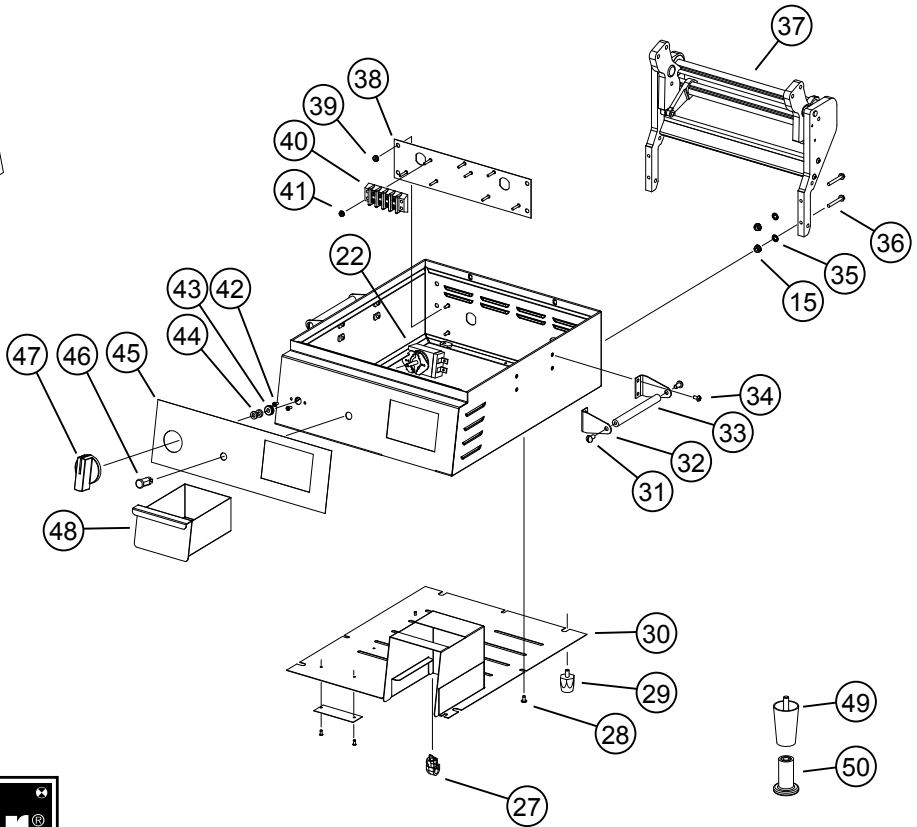

SK2821, Rev. - 12/10/14

Model: TG14, 14" Sandwich Grill

2M-Z19329 Toastmaster TG14 Sandwich Grills

PARTS LIST

December 10, 2014, Rev. -

14' TWO SIDED GRILLS

Model: TG14 Series Sandwich Grill				
Fig. No.	Part Number	Quantity	Description	Application
1	2C-40637	6	NUT 1/4-20 ACORN CAP MS S	
2	2C-Z2992	6	BOLT 1/4-20X1 PHP STL NP	
3	2B-Z2987	2	ARM - 14"	TG14-IS, TG14IG
	2B-Z3336		14" GR14SPT ARM	TG14-AG, TG14-AS
4	2C-Z3200	2	PIN - TOP HOUSING	
5	2E-Z2898	1	CONDUIT ASSY. - PTFE	
6	2C-Z3917	2	RIVET, POP, .188 (AD66BS)	
7	2C-Z3780	2	RETAINER, CONDUIT	
8	2A-Z3827	1	PLATE,STAMPING - CONDUIT	
9	2C-Z5883	8	10-24 X 1/2 FZA SCREW	
10	D9-Z4849	1	HOUSING - TOP - 14"	
11	2V-Z2989	1	HANDLE- 14"	
12	B9-04-WB-0046	1	CLAMP WIRE SUPPORT	
13	2C-Y1451	2	RIVET 1/8 x .337 MORISON	
14	D9-Z13012	1	WIRE MOUNT	
15	2C-Z2893	12	NUT 10-24 HEX STL ZP	
16	D9-Z13099	2	BRACKET, INSLUATION	
17	D9-Z2075	1	TOP ELEMENT/INS. PLATE/14	
18	2N-Z1980	1	ELEMENT,800WATT 120V-14T	120V
	2N-Z2391		ELEMENT 1800WATT 240V-14T	240V
19	2C-08-07-0285	8	SCREW 10-24X3/4X3/8 TYPE	
20	2F-Z1946	1	CASTING,GR. TOP, ALUM.-14"	TG14-AG
	2F-Z1948		CASTING, SM.TOP,IRON-14	TG14-IS
	2F-Z1950		CASTING,GR.TOP, IRON-14"	TG14-IG
	2F-Z7786		TOP CASTING, SM, AL.-14"	TG14-AS
21	2F-Z11953	1	BOT. CAST.SMOOTH 14 ALUM.	TG14-AS
	2F-Z11954		BOT. CAST GROOVED 14 ALUM	TG14-AG
	2F-Z1949		CASTING,SM. BOT.,IRON-14"	TG14-IS
	2F-Z1951		CASTING, GR. BOT.,IRON-14"	TG14-IG
22	2T-6447	1	THERMOSTAT 118V-236V	
23	2N-Z1981	1	ELEMENT,1000WATT 120V-14B	120V
	2N-Z2392		ELEMENT 1800WATT 240V-14B	240V
24	D9-Z13338	1	ELEMENT & INSULATION PLT	
25	D9-Z2888	2	INSULATION - 14"	
26	D9-Z12885	2	INSULATION HOLD DOWN,	
27	2K-Y3240	1	BUSHING - STRAIN RELIEF	120V
	2K-Y6764		BUSHING - STRAIN RELIEF	240V
28	2A-Z11501	4	FOOT 1" SOLID RUBBER	TG14-AG, TG14-AS
29	2C-6349	8	SCREW #8X3/8 B THP STL NP	
30	D9-GR0525	1	BASE/GRS CAB/CORD PLT ASM	
31	2C-1522	4	SCREW 1/4-20X.5 STL R.H.	
32	D9-Z3071	4	BRACKET - HANDLE	
33	2V-Z3072	2	HANDLE-SIDE	

2M-Z19329 Toastmaster TG14 Sandwich Grills

Model: TG14 Series Sandwich Grill

Fig. No.	Part Number	Quantity	Description	Application
34	2C-1512	8	SCREW 10-24X3/8 RHP STL	
35	2C-08-07-0262	4	WASHER, SS 1/4 INT-LOCK	
36	2C-Z2593	4	10-24x1 1/2 SL HX/W NP	
37	2R-Z1951	1	CASTING, GR. BOT., IRON-14"	TG14-IG, TG14-IS
	2R-Z2897		COUNTER BALANCE/14"/ALUM.	TG14-AG, TG14-AS
38	2E-Z2894	1	TERMINAL BLOCK (304)	
38	D9-GR0156	1	REAR PLATE ASSY.	
40	2C-Z2594	2	NUT 6-32 HEX W STL NP	
41	2C-Z3447	4	NUT 8-32 HEX W SS	
42	2C-1488	2	SCREW 6-32X3/8 RHP STL NP	
43	2I-Z3379	1	GROMMET-THERMOSTAT	
44	2I-Z3380	2	THERMOSTAT SEAL WASHER	
45	2M-Z19183	1	LABEL - CONTROL PANEL TSG	
46	2J-Y6689	1	PILOT LIGHT 120V	120V
	2J-Z2329		PILOT LIGHT	240V
47	D9-GR0709	1	KNOB ASSY PRO-MAX 2.0	
48	D9-GR0518	1	GREASE DRAWER ASSY	
49	2A-Z12946	4	2.5" FOOT BASE, 1/4-20	TG14-IS, TG14IG
50	2A-Z19356	4	BASE, FOOT, NON-SKID	TG14-IS, TG14IG
NI	2E-Z2905	1	CORD SJTO 12/3 NEMA 6-20P	240V
	2E-Z2935		CORD SJTO 14/3 NEMA 5-15P	120V
NI	2E-Z4119	1	POWER CORD, 12/3, 5-20P	120C



Warranty Statement

Toaster warrants equipment that it manufactures to be free from defects in material and workmanship. Toaster's obligation is limited to repairing or replacing, at Toaster's option, without cost to the customer, any part found to be defective, as well as any labor or material expense required to replace the part.

Length of Warranty

This warranty is effective for a period of 12 months from the date the equipment is placed in service.

Exceptions

- This warranty is valid only for the original end user owner/operator of the equipment.
- This warranty does not apply to normal maintenance functions, including (but not limited to) improper operation, installation or the use of an improper utility supply.
- This warranty is valid only if the equipment is used in a commercial setting. The equipment is designed and constructed for commercial use by trained professionals only. Any use of the equipment in private or domestic applications immediately voids this warranty.
- This warranty does not apply to any parts, labor and material expenses for service that is not pre-approved and performed by a Toaster authorized service agent. Any such service immediately voids this warranty.
- This warranty does not apply to any parts, labor and material expenses associated with the installation of parts that are not factory-approved for use in the equipment. Any use of such parts immediately voids this warranty.
- This warranty is not valid if terms of payment have not been met.

Parts Warranty

Parts that are sold to repair our of warranty equipment are warranted for ninety (90) days. The part only is warranted, the labor to replace the parts is NOT warranted.

Portable Equipment

Toaster will not honor service bills that include travel time and mileage charges for servicing any products considered "Portable". These products should be taken to the Service Agency for repair.

A portable unit is a unit that's designed to sit on a countertop, has a powercord & is less than 50lbs installed.

Toaster reserves the right to change the design and specifications of this equipment or any related documentation at any time. The end user is not entitled to upgrades resulting from these changes.

This warranty is exclusive and supersedes all other warranties for the equipment, both expressed and implied. There are no implied warranties of merchantability or of fitness for a particular purpose.

The foregoing is Toaster's sole and exclusive obligation and the end user sole and exclusive remedy for any action including breach of contract or negligence. In no event shall Toaster be liable for a sum in excess of the purchase price of the equipment, or for any prospective or lost profits of the end user.