



Rolling Tortilla Warmer

Owner's Manual

Models

RTW14EA and RTW19EA

patent no. 9,516,883

This manual includes material related to installation, use, cleaning, and care. Exploded view[s], as well as any available parts list[s] and wiring diagram[s] pertaining to the unit[s] covered by this manual are also included.

This manual must be read and understood by all persons using or installing this appliance. Contact your Star dealer if you have any questions concerning installation, use, or maintenance of this equipment.

DO NOT DISCARD THIS MANUAL.



RTW14EA

LIMITED EQUIPMENT WARRANTY

Star Manufacturing [as well as its subsidiaries] warranties new products to be free from defects in material and/or workmanship for a period of one [1] year from the date of original installation, except as noted below. Defects that occur as a result of normal use, within the time period and limitations defined in this warranty, will at Star's discretion have the parts replaced or repaired by Star or a Star-authorized service agency.

THIS WARRANTY IS SUBJECT TO ALL LISTED CONDITIONS.

Repairs performed under this warranty are to be performed by a Star-authorized service agency. Star will not be responsible for charges incurred or service performed by non-authorized repair agencies. In all cases, the nearest Star-authorized service agency must be used.

Star will be responsible for normal labor charges incurred in the repair or replacement of a warrantied product within 50 miles (80.5 km) of an authorized service agency. Time and expense charges for anything beyond that distance will be the responsibility of the owner. All labor will need to be performed during regular service hours. Any overtime premium will be charged to the owner. For all shipments outside the U.S.A. and Canada, please see the International Warranty for specific details.

It is the responsibility of the owner to inspect and report any shipping damage claims, hidden or otherwise, promptly following delivery.

No mileage or travel charges will be honored on any equipment that is deemed portable. In general, equipment with a cord and plug weighing less than 50 lb. (22.7 kg) is considered portable and should be taken or shipped to the closest authorized service agency, transportation prepaid.

PORTABLE EQUIPMENT EXAMPLES

- 514LL fryer
- 15MC and 18MCP hot food merchandisers
- QCS1, QCS2, and RCS2 toasters
- 16PD-A pretzel merchandisers
- condiment dispensers except HPD- and SPD-series models
- all pop-up toasters
- all pastry display cabinets
- all heat lamps
- J4R popcorn machine
- 12NCPW and 15NCPW nacho merchandisers
- nacho cheese warmers except 11WLA-series models
- specialty food warmers except 130R, 11RW, and 11WSA models
- all butter dispensers
- all nacho chip merchandisers
- all accessories

CONTACT

Should you require any assistance regarding the operation or maintenance of any Star equipment; write, phone, fax or email our service department. In all correspondence mention the model number and the serial number of your unit, as well as the voltage or type of gas you are using.

Business hours are 8:00 a.m. to 4:30 p.m. Central Standard Time
Telephone *Star/Toasmaster* 314.678.6306

Fax 314.781.2714

Email customerservice@star-mfg.com

www.star-mfg.com • www.toastmastercorp.com

WARRANTY EXCLUSIONS

THE FOLLOWING WILL NOT BE COVERED UNDER WARRANTY.

- Any product which has not been used, cleaned, maintained, or installed in accordance with the directions published in the appropriate installation sheet and/or owner's manual as well as national and local codes, including incorrect gas, electrical, or water connection. Star is not liable for any unit which has been mishandled, abused, misapplied, subjected to chlorides, harsh chemicals, or caustic cleaners, damaged from exposure to hard water, modified by unauthorized personnel, damaged by flood, fire, or other acts of nature [or God], or which have an altered or missing serial number.
- Installation, labor, and job checkouts, calibration of heat controls, air and gas burner/bypass/pilot adjustments, gas or electrical system checks, voltage and phase conversions, cleaning of equipment, or seasoning of griddle surface.
- Replacement of fuses or resetting of circuit breakers, safety controls, or reset buttons.
- Replacement of broken or damaged glass components, quartz heating elements, and light bulbs.
- Labor charges for all removable parts in gas charbroilers and hotplates, including but not limited to burners, grates, and radiants.
- Any labor charges incurred by delays, waiting time, or operating restrictions that hinder a service technician's ability to perform service.
- Parts that fail or are damaged due to normal wear or labor for replacement of Items that can easily be replaced during a daily cleaning routine. such as but not limited to silicone belts, PTFE non-stick sheets, knobs, control labels, bulbs, fuses, quartz heating elements, baskets, racks, and grease drawers.
- Components that should be replaced when damaged or worn, but have been field-repaired instead [eg. field-welded fry pots]
- Any loss of business or profits.

ADDITIONAL WARRANTIES

Specialty/chain specific versions may also have additional and/or extended warranties.

PRODUCTS	PARTS	LABOR
Star Ultra-Max® griddles, charbroilers, and hotplates	2 years	2 years
Star-Max® fryers, griddles, charbroilers, and hotplates	2 years	2 years
Jetstar® popcorn poppers	2 years	2 years
Staltek™ roller grill coatings	5 years	
chrome griddle surfaces [against peeling]	5 years	
cast iron grates, burners, and burner shields	180 days	
original Star or Toastmaster parts sold to repair Star or Toastmaster equipment	90 days	
Service First	1 year	

The foregoing warranty is in lieu of any and all other warranties expressed or implied and constitutes the entire warranty.

2M-Z21647 • Rev C • 02.2018

TABLE OF CONTENTS

Warranty	i
General Information and Installation	1-2
Daily Operation	3-4
Cleaning	5
Maintenance	6
Wiring Diagram	7
Exploded Views	8-13
Parts List	14-17
Wall Mount Installation	18-19
Specifications	20

NOTES

SAFETY SYMBOLS

These symbols are intended to alert the user to the presence of important operating and maintenance instructions in the manual accompanying the appliance.

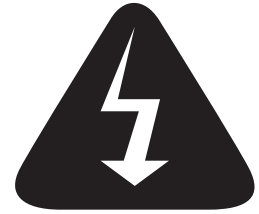

THOROUGHLY INSPECT YOUR UNIT ON ARRIVAL

This unit has been tested for proper operation before leaving our plant to ensure delivery of your unit in perfect condition. However, there are instances in which the unit may be damaged in transit. In the event you discover any type of damage to your product upon receipt, you must immediately contact the transportation company who delivered the item to you and initiate your claim with that company. If this procedure is not followed, it may affect the warranty status of the unit. Please record the model number, serial number, voltage, and purchase date in the area below at the time of receipt..

Model Number _____

Serial Number _____

Voltage _____

Purchase Date _____

NOTICE

Using any part other than genuine Star factory supplied parts relieves the manufacturer of all liability. Due to periodic changes in designs, methods, procedures, policies, and regulations, the specifications contained in this sheet are subject to change without notice. Star reserves the right to change product specifications and design without notice. Such revisions do not entitle the buyer to corresponding changes, improvements, additions or replacements for previously purchased equipment. While Star International Holdings Inc. exercises good faith efforts to provide information that is accurate, we are not responsible for errors or omissions in information provided or conclusions reached as a result of using the specifications. By using the information provided, the user assumes all risks in connection with such use.

PLEASE REFER TO THE WARRANTY PAGE FOR SPECIFIC WARRANTY INFORMATION.

MAINTENANCE AND REPAIRS

Contact your local authorized service agent for service or required maintenance. Please have the information in the above fields ready when you call to ensure a faster service.

AUTHORIZED SERVICE AGENT LISTING

Reference the listing provided with the unit or for an updated listing go to the website or call customer service to find an agent.

Business hours: 8:00 a.m. to 4:30 p.m. Central Standard Time

Telephone: 314-678-6303

Fax: 314-781-2714

Email: customerservice@star-mfg.com

Website: www.star-mfg.com



GENERAL SAFETY INFORMATION

This equipment is designed and sold for commercial use only, and is intended for use by personnel trained and experienced in its operation. This is not sold for consumer use in and around the home nor for use directly by the general public in food service locations.

Before using your new equipment, read and understand all the instructions and labels associated with the unit prior to putting it into operation. Make sure all people associated with its use understand the units operation and safety before they use the unit.

GENERAL INSTALLATION INFORMATION

The unit is shipped fully assembled and ready to plug into a standard outlet specified for its voltage and amp draw. If improper electrical supply can be determined through troubleshooting, contact a qualified electrician prior to using the unit. Removal or replacement of the power cord or plug will void the warranty. Should you require assistance, contact your local authorized service agent for any service or required maintenance.

Level unit using the adjustable feet under the unit [there is approximately 0.5 (1/2) inch of adjustment]. Allow enough space around the unit for adequate ventilation. It is recommended that you leave a ten (10) inch gap on the top for cleaning if the unit is to remain stationary. The sides and back of the unit require no additional clearance.

Before using the unit for the first time, make certain to clean it properly. Refer to the "Cleaning Procedure" document for cleaning instructions. The inlet and outlet trays will also need to be placed on the unit prior to use. The outlet tray slides on the lip under and in front of the drum area and the inlet tray sits on a rod, resting against the stop pins.

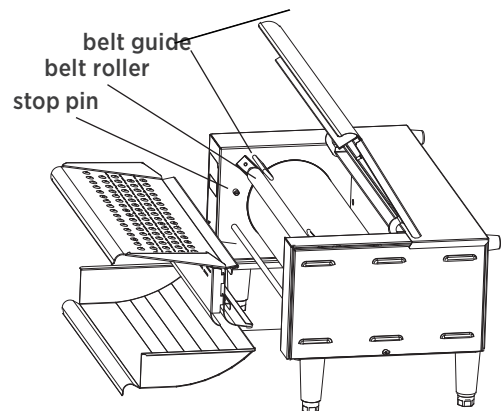
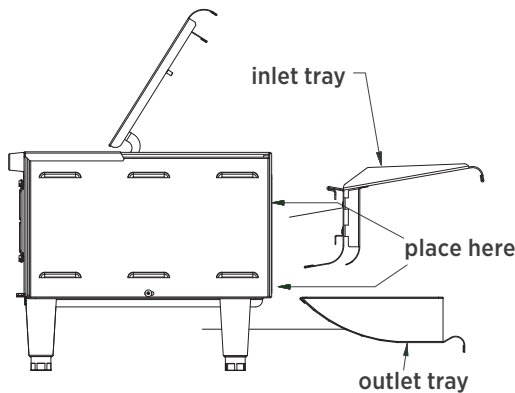

ELECTRICAL CONNECTION

Before making any electrical connection to this unit, check that the power supply is adequate for the voltage, amperage, and requirements stated on the rating plate. RTW14EA units will require a NEMA 5-20P receptacle. RTW19EA units will require a NEMA 6-15P receptacle. Make certain to disconnect the unit from the power source before installing or removing any parts. Be absolutely sure that the ground connection for the receptacle is properly wired. Do not connect equipment to power without proper ground connections. Improper grounding may result in personal injury or fatality.



DO NOT CUT OR REMOVE THE PLUG OR GROUNDING PRONG FROM THE PLUG.



CONNECT UNIT INTO DEDICATED AC LINE ONLY AS SPECIFIED ON THE DATA PLATE OF THE UNIT.



DO NOT IMMERSE OR LET THE UNIT STAND IN WATER.



DO NOT HOSE DOWN THE UNIT OR THE TABLE/COUNTER IF THE UNIT IS ON THE TABLE/COUNTER.



DAILY OPERATION

CERTAIN SURFACES ARE EXTREMELY HOT DURING OPERATION AND CARE SHOULD BE TAKEN WHILE USING THIS UNIT.

THIS UNIT IS DESIGNED TO WARM DRY, FLEXIBLE PRODUCTS ONLY. DO NOT ATTEMPT TO RUN WET OR LOOSE MATERIAL THROUGH IT.

ELECTRONIC CONTROLS

BUTTONS (PRIMARY USES)

- **ON/OFF**—Turns power on or off to the electrical components of the unit.
- **SET/TEMP**—Allows adjustment of the roller heating element temperature up to 480°F (249°C).
- **▲** — Adjusts settings upward in menus.
- **▼** — Changes between bread and tortilla mode and adjusts settings downward in menus.

FUNCTIONS/MODES

- **ON/OFF**—All power is turned on, or removed from, the drum motor, heating elements, and cooling fan. After powering down, the screen will display “OFF” until the “ON/OFF” button is pressed again. Cooling fan will be on in all modes other than when the unit is powered down.
- **PREHEAT**—Drum motor runs at the set “TORT” speed. Heaters bring the drum temperature up to the set operating temperature.
- **TORT**—Drum motor runs at the set “TORT” speed. Heaters maintain the drum temperature at the set operating temperature.
- **BREAD**—Drum motor runs at the set “BREAD” speed. Heaters maintain the drum temperature at the set operating temperature. This mode only lasts for 1-40 seconds before defaulting back to *TORT* mode.
- **COOL**— Drum motor runs at the set “TORT” speed. Heaters are off.
- **CLEAN**— Drum motor does not run. Heaters are off.

START-UP

- When the unit is initially plugged in, the display will read “OFF” for a brief time. No outputs will receive power at this time.
- When “ON/OFF” is pressed, the drive motor, heating elements, and fan motor will be turned on. The *PREHEAT* mode will start immediately and will take approximately twenty (20) minutes to complete. During this time, “PREHT” will appear on the display. Do not attempt to adjust temperature or speed settings until *PREHEAT* has completed.
- The temperature of the drum can be checked at any time in *PREHEAT* or *TORT* modes by pressing the “SET/TEMP” button. If the temperature has not yet reached 100°F (38°C), the words “LOW” and “TEMP” will flash on the screen.
- There will be a small dot on the lower right of the screen which will remain on whenever the heating elements are on. When the *PREHEAT* mode has completed, “TORT” will be displayed on the screen.



1/2 scale RTW
control panel

TEMPERATURE ADJUSTMENT

This can be performed in *RUN* (*TORT* or *BREAD*) and *CLEAN* modes.

- i. Press and hold the “SET/TEMP” button for three (3) seconds. The display flashes the drum temperature setting and the “DRUM TEMP” light on the front label illuminates as well.
- ii. Use the ▲ and ▼ buttons to adjust the drum heat to the desired temperature. The display will stop flashing while ▲ or ▼ are pressed and will indicate the temperature and units. The temperature can be adjusted from 210°F–480°F (99°C–249°C). Adjustments of 10°F or 10°C at a time can be made depending on which the unit is set to read at the time adjusted.
- iii. Press the “SET/TEMP” button when you are satisfied with your adjustment and move on to a screen which will allow you to toggle between Fahrenheit and Celsius.
- iv. Press the “SET/TEMP” button again to save and exit this mode.

DRUM SPEED ADJUSTMENT

This can be performed in *RUN* mode (*TORT* or *BREAD*).

- v. Press and hold the ▲ and ▼ buttons simultaneously for three (3) seconds. The display will sequence through “TORT”, “SPEED”, and the current “TORT SPEED” speed setting number.
- vi. Press the ▲ button to increase the set speed and the ▼ to decrease the set speed. The speed setting can range from 1–99 and holding the ▲ or ▼ button will make the setting increase or decrease until a limit is reached.
- vii. Press “SET/TEMP” again to save the selected setting. The display will now sequence through “BREAD”, “SPEED”, and the current “BREAD SPEED” setting number. This is adjusted using the same procedure as the above “TORT SPEED” in the section above.
- viii. Press the “SET/TEMP” again to save the selected setting. The display will now sequence through “BREAD”, “TIME”, and the current time setting. Bread mode is only activated for a brief time determined by this setting. Press the ▲ button to increase the set time and the ▼ to decrease the set time anywhere from 1–40 seconds and holding the ▲ or ▼ button will make the setting increase or decrease until a limit is reached.
- ix. Pressing “SET/TEMP” one more time will exit speed adjustment.

CLEANING



DO NOT IMMERSE OR LET THE UNIT STAND IN WATER.



DO NOT HOSE DOWN THE UNIT OR THE TABLE/COUNTER IF THE UNIT IS ON THE TABLE/COUNTER.



DO NOT USE CAUSTIC CLEANERS ON ANY SURFACE OF THE UNIT.



DO NOT USE ANY ABRASIVE CLEANING UTENSILS ON ANY PART OF THE UNIT.

Preventive maintenance for your unit consists of the following recommended cleaning procedures. In order to keep your tortilla warmer in top operating condition, these steps should be performed daily or weekly as indicated.

CLEAN MODE

CLEAN mode is a cool down notification feature alerting the user when the unit reaches a safe handling temperature. Press the “ON/OFF” button once to activate *CLEAN* mode. The inlet and outlet trays and scraper are removable for easy access for cleaning. The recommended cleaner to use is *Kay QSR heavy-duty degreaser*.

CLEANING PROCEDURE

- i. Press the “ON/OFF” button once to enter *COOL DOWN* mode. The screen will read “*COOL*” until the unit reaches a safe temperature.
- ii. Remove the silicone belt with the belt roller and wipe them down with a damp cloth.
- iii. Remove the inlet and outlet tray. Wash using warm water and mild detergent.
- iv. Clean using warm water and detergent. Wipe the drum using a damp cloth.
- v. Reassemble the parts previously removed.

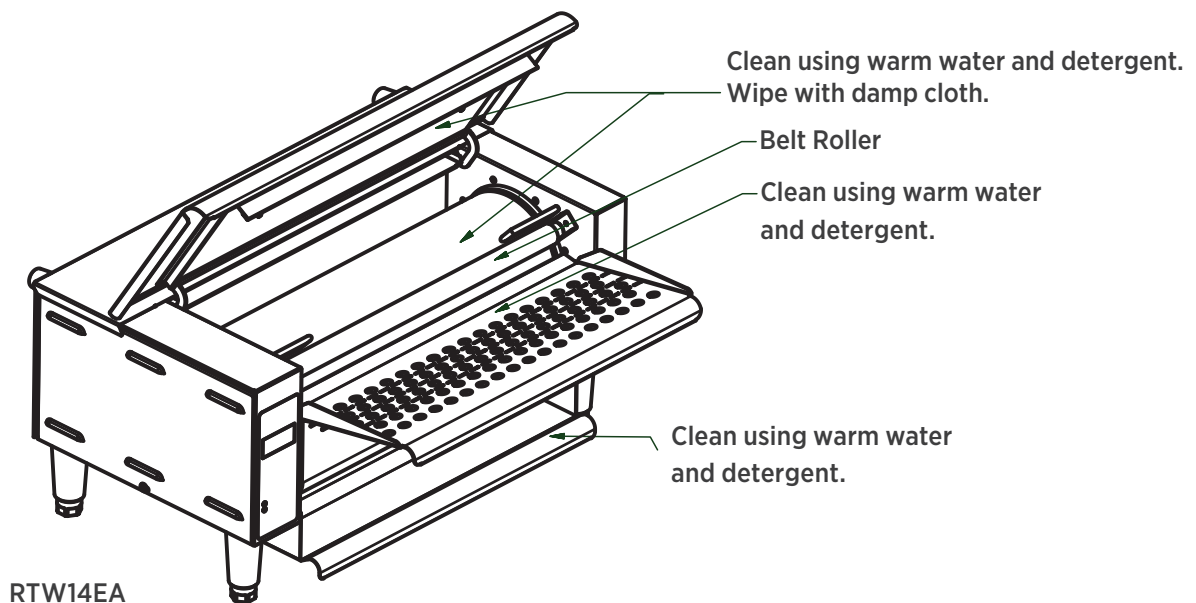

MAINTENANCE



POWER MUST BE REMOVED FROM THE UNIT
BEFORE ATTEMPTING MAINTENANCE OR SERVICE.

CLEANING THE AIR INTAKE

DISCONNECT UNIT FROM POWER SOURCE

- i. Use a vacuum or wipe down with a damp cloth to remove debris.

LUBRICATING THE CHAIN AND SPROCKETS (recommended every 6 months)

DISCONNECT UNIT FROM POWER SOURCE

- i. Remove the screw holding the right side panel and remove the panel.
- ii. Use an extreme pressure synthetic chain lubricant rated up to at least 400°F (204°C) [Star part number [1L-Z12397](#)] and liberally lubricate the chain and sprockets.
- iii. Reinstall the side panel using the previously removed hardware.

REPLACING THE BELT

- i. Replace the silicon belt [2I-Z22463] after approximately one thousand [1000] hours of use, or three [3] months of ten [10] hour days.

WIRING DIAGRAM



POWER MUST BE REMOVED FROM THE UNIT BEFORE ATTEMPTING REPAIR OR SERVICE. MAKE CERTAIN TO CHECK ALL CONNECTIONS THOROUGHLY BEFORE RESTORING POWER TO THE UNIT. THE BELOW INFORMATION IS FROM WIRING DIAGRAM 2M-Z22547.

Please review the following information before proceeding with any electrical diagnosis or repair.

- i. Check for proper voltage jumper connection on power board.
- ii. Fan cord, communication cable, IR sensor cable, and tachometer are not numbered.
- iii. Hold back-up nut when tightening element terminals to prevent twisting the cold pin.
- iv. Make certain that infrared sensor is supported when inserting connector.

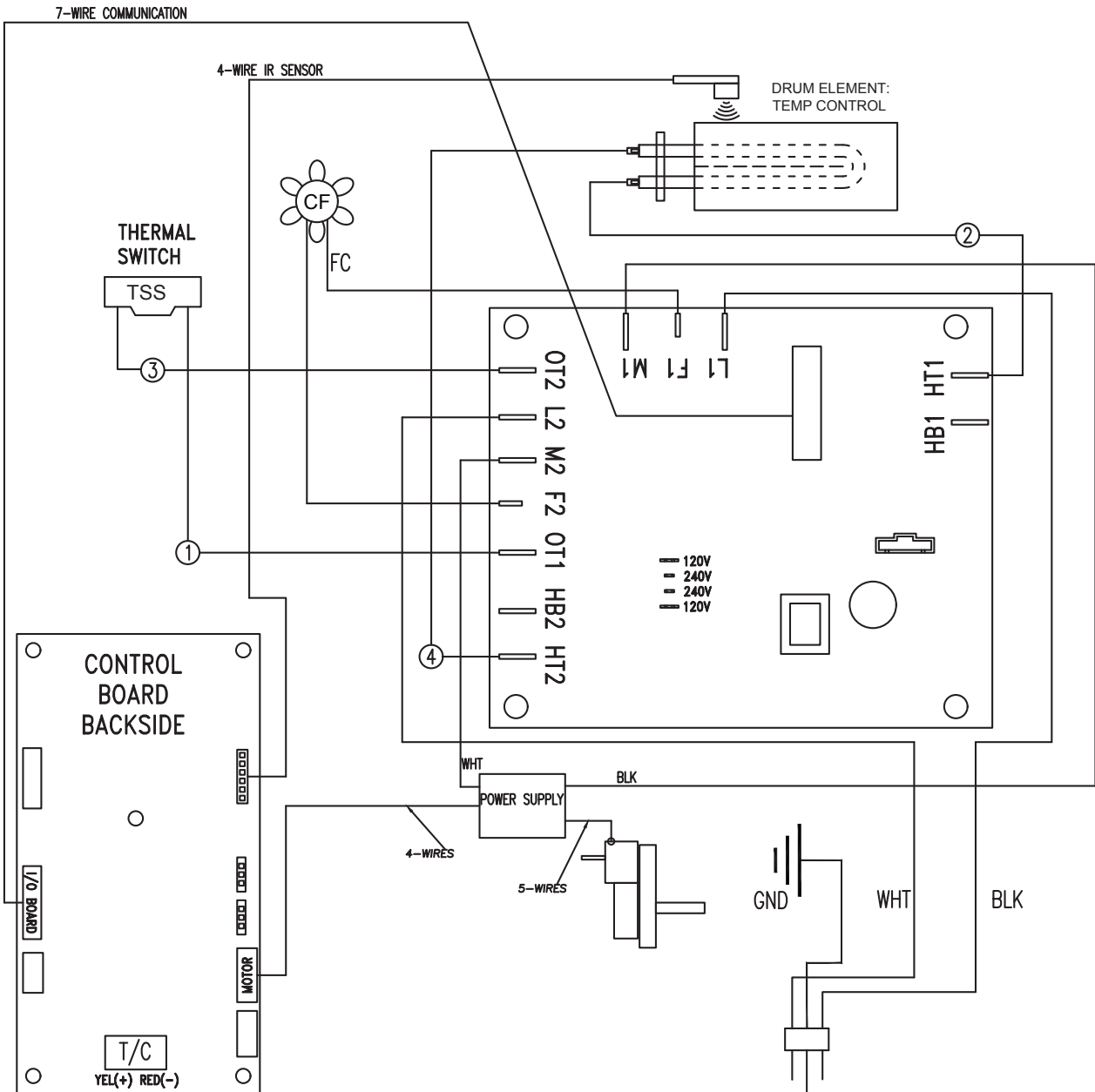

CENTER DRUM, ROLLERS, AND ELEMENTS

RTW14EA pictured

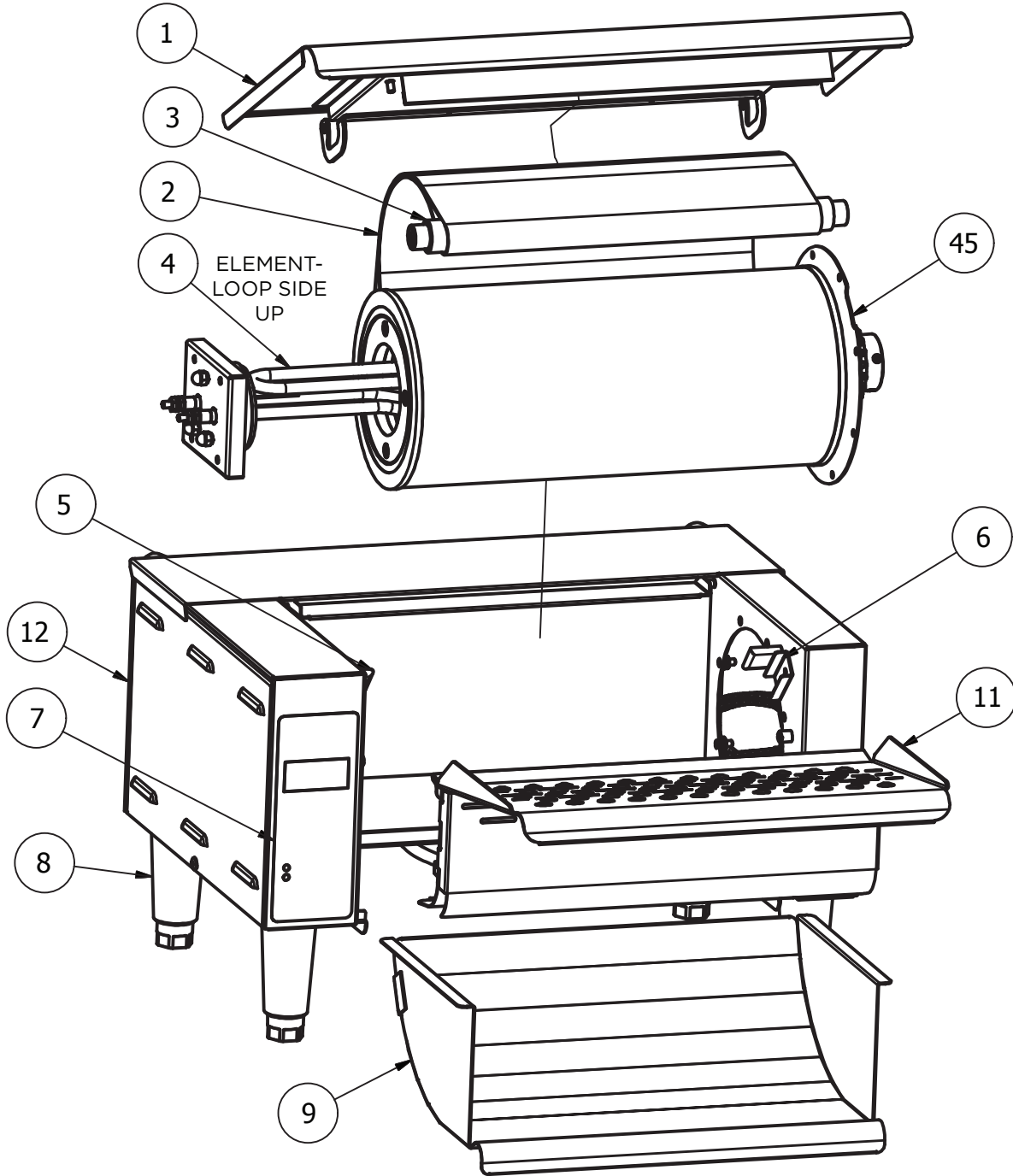

RIGHT SIDE [CHAIN DRIVE]

RTW14EA pictured

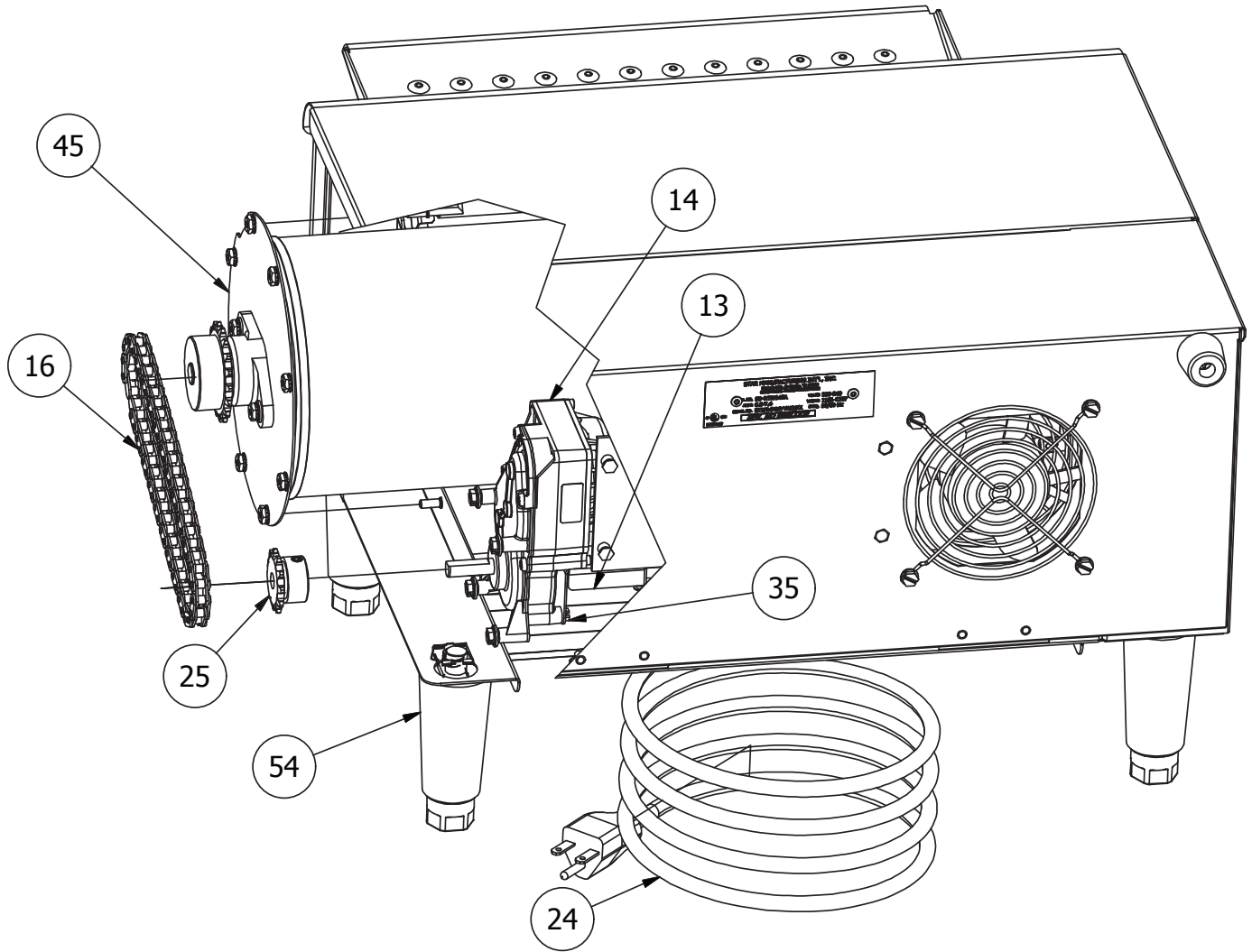

LEFT SIDE [PANEL]

RTW19EA pictured

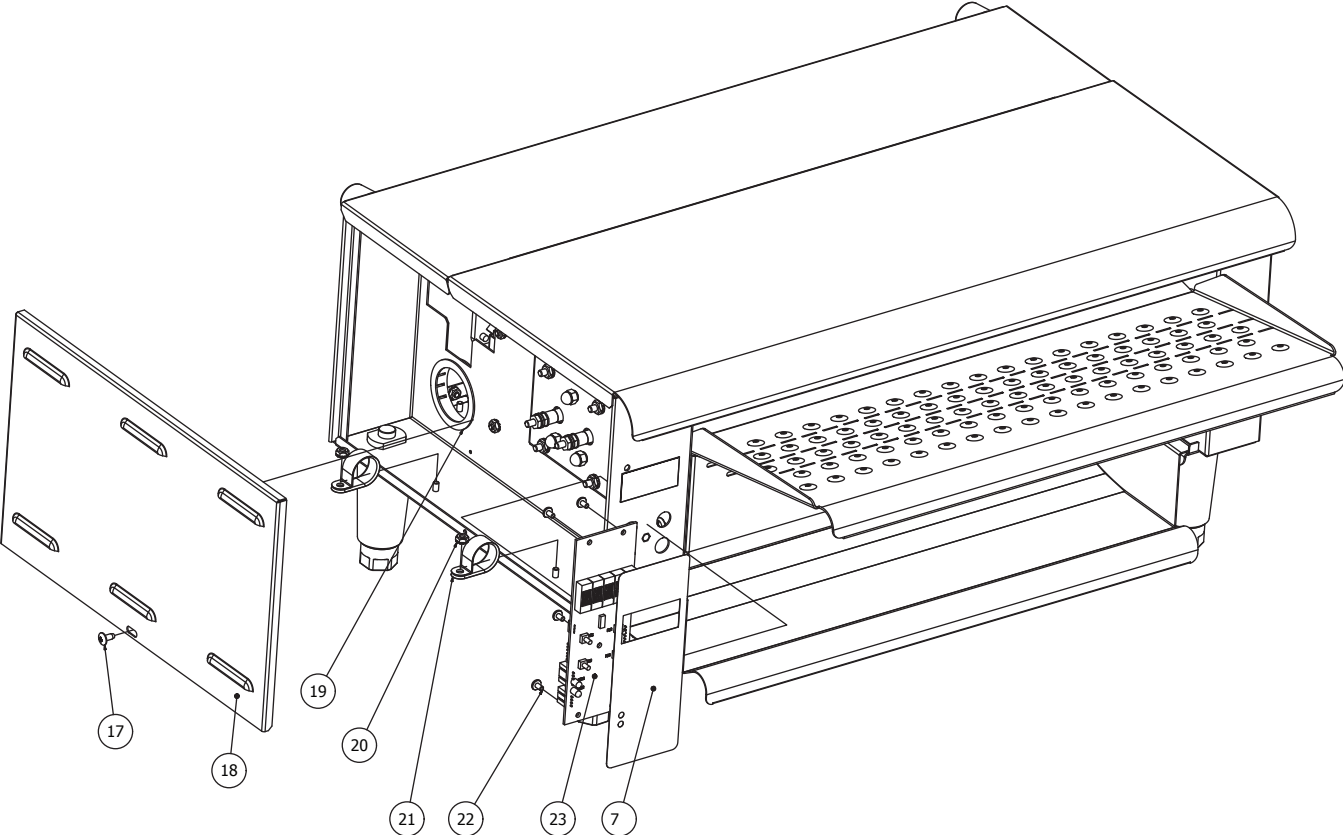

REAR [1]

RTW19EA pictured

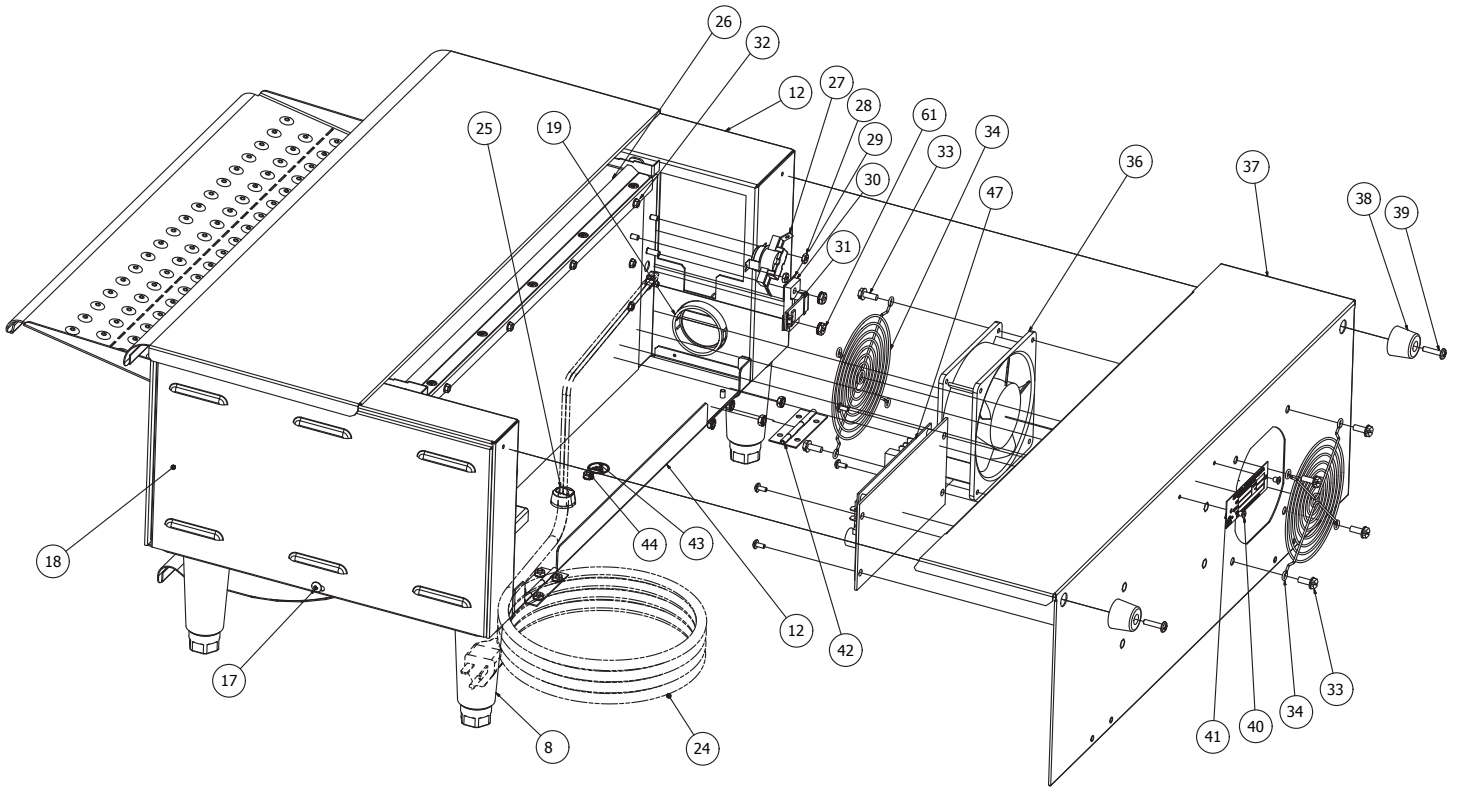

REAR [2]

RTW19EA pictured

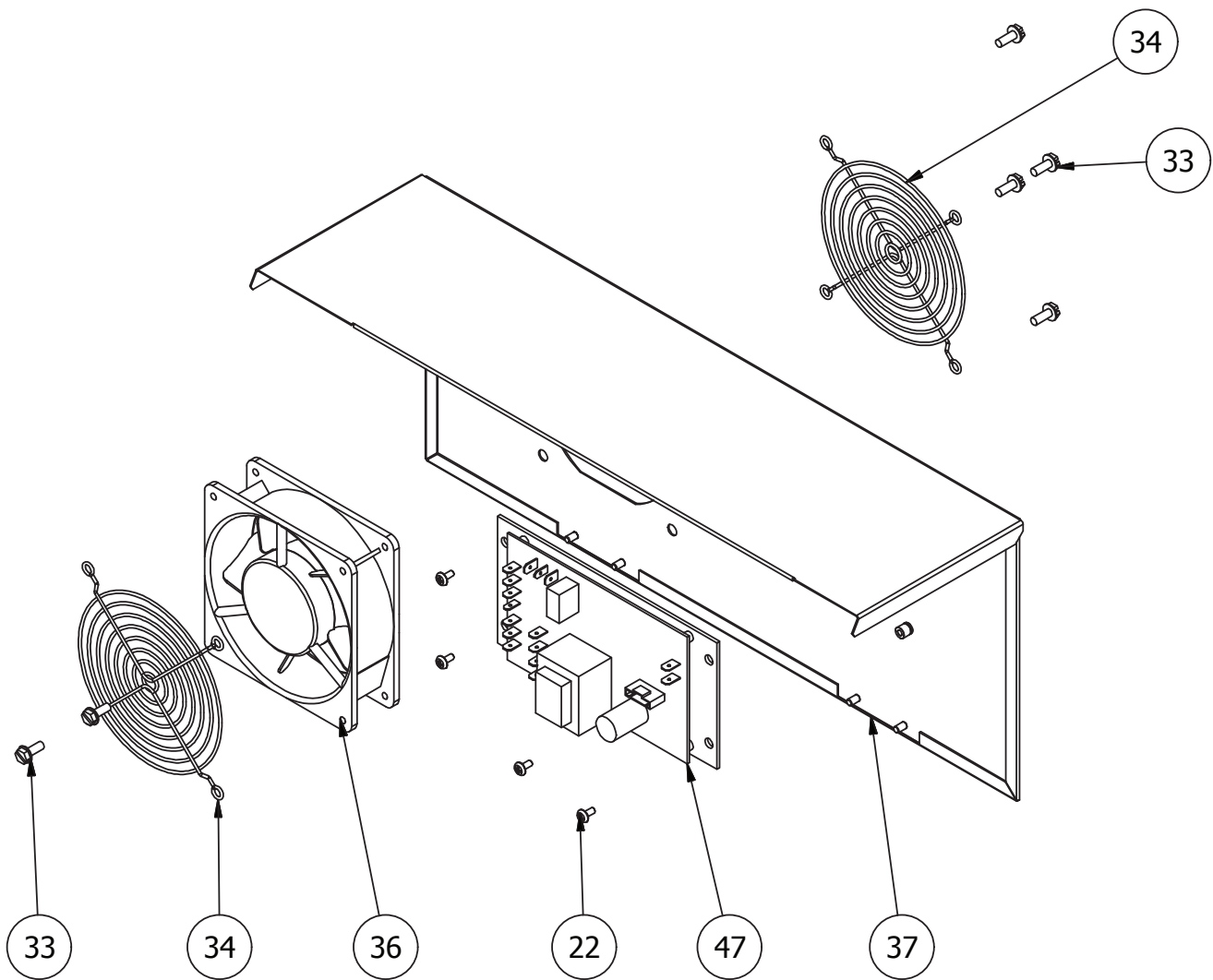

CENTER SECTION

RTW14EA pictured

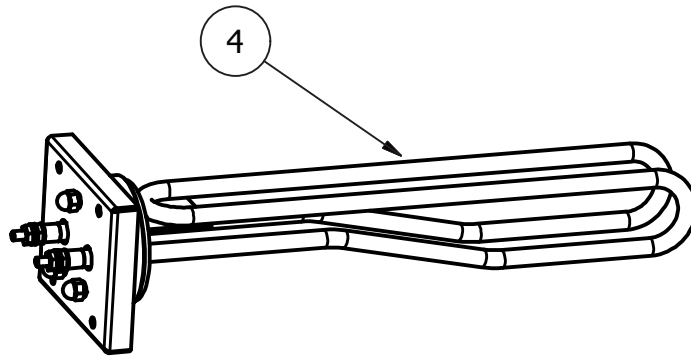
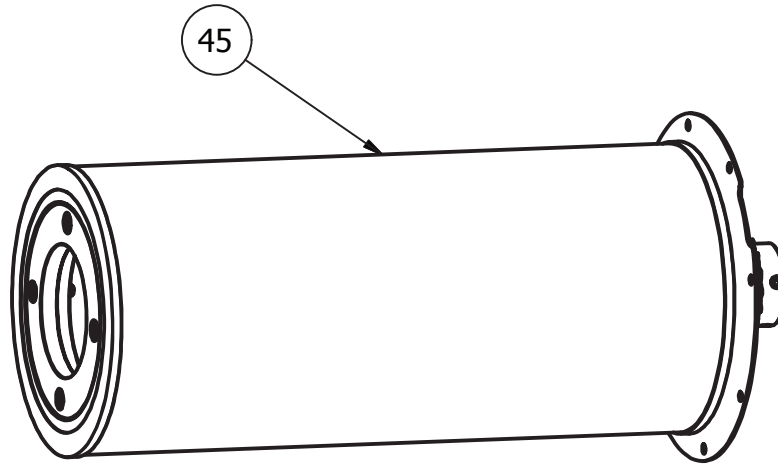

PARTS LIST

REF NO	MODEL	PART NUMBER	DESCRIPTION	QTY	PAGE NO
1	RTW14EA	D6-RTW086	ASSY,TOP,FRONT, RTW-14	1	8
	RTW19EA	D6-RTW068	ASSY,TOP,FRONT, RTW-19		8
2	ALL RTW	2I-Z22463	BELT,SILCON,12"W	1	8
3	RTW14EA	D6-RTW090	ASSY,ROLLER,IDLER,RTW-14	1	8
	RTW19EA	D6-RTW075	ASSY,ROLLER,IDLER,RTW-19		8
4	RTW14EA	D6-RTW091	ASSY,ELEMENT,120V,1750W	1	8
	RTW14EA	D6-RTW092	ASSY,ELEMENT,208-240V,1750W		8
	RTW19EA	D6-RTW074	ASSY,ELEMENT,208-240V,1750W		8
5	RTW14EA	D6-Z22649	GUIDE,BELT	2	8
	RTW19EA	D6-Z22592			8
6	RTW14EA	2A-Z18673	INFEED SUPPORT ROD RTW14	1	8
	RTW19EA	2A-Z22560	INFEED SUPPORT ROD RTW19		8
7	ALL RTW	2M-Z18246	LABEL, CONTROL TW ELEC	1	8
8	ALL RTW	2A-Z5942	FOOT, 1/2-13 X 4"L.	4	8
9	RTW14EA	D6-Z22648-1	CATCH PAN WELDMENT	1	8
	RTW19EA	D6-Z22576			8
10	ALL RTW	D6-Z22489-1	SUPPORT,BEARING,PEM	2	8
11	RTW14EA	D6-RTW089	ASSY,INFEED,RTW-14	1	8
	RTW19EA	D6-RTW067	ASSY,INFEED,RTW-19		8
12	RTW14EA	D6-RTW083	ASSY,CHASSIS,RTW-14	1	8
	RTW19EA	D6-RTW065	ASSY,CHASSIS,RTW-19		8
13	ALL RTW	D6-Z20933	POWER SUPPLY BRACKET	1	9
14	ALL RTW	2U-Z19838	GEARMOTOR 24V BLDC 15RPM	1	9
15	ALL RTW	2P-Z22457	SPROCKET,35BS11 .375ID	1	9
16	ALL RTW	2P-Z18415	CHAIN #35 18.75" 50 LINKS	1	9
17	ALL RTW	2C-6349	SCREW #8X3/8 B THP STL NP	2	10
18	ALL RTW	D6-Z22470	PANEL,SIDE	2	10
19	ALL RTW	2K-Y8571	BUSHING SNAP 2 1/8	1	10
20	ALL RTW	2C-31053	NUT 8-32 KEPS MS NICKEL	20	10
21	ALL RTW	2C-200467	CLAMP, NYLON WIRE 5/8	2	10
22	ALL RTW	2C-200067	SCREW 6-32X1/4 THP SS	9	10
23	ALL RTW	2J-Z20026	CONTROLLER, RTWE IR TEMP	1	10
24	RTW14EA	2E-Z13852	120V CORDSET, 14/3 5-20P TERMS	1	11
	RTW14EA	2E-Z19137	240V CORDSET, 14/3 6-15P TERMS		
	RTW19EA	2E-GR0411	240V CORDSET, 14/3 CH2-16P TERMS		

PARTS LIST CONTINUED

REF NO	MODEL	PART NUMBER	DESCRIPTION	QTY	PAGE NO
25	ALL RTW	2K-Y6764	BUSHING - STRAIN RELIEF	1	11
26	RTW14EA	D6-RTW087	ASSY,DEFLECTOR,AIR RTW14	1	11
	RTW19EA	D6-RTW072	ASSY,DEFLECTOR,AIR RTW19		11
27	ALL RTW	2T-Z22461	THERMOSTAT,HI-LIMIT	1	11
28	ALL RTW	2C-200200	NUT, 6-32 HEX	2	11
29	ALL RTW	D6-Z20718	IR SENSOR RETAINER	1	11
30	ALL RTW	2A-Z20443	SENSOR HOLDER	1	11
31	ALL RTW	2E-Z20415	IR TEMP SENSOR	1	11
32	ALL RTW	2C-8833	SCREW 8-18X1/2 HEX STL NP	6	11
33	ALL RTW	2C-Z9632	10-32 X 1/2 SCREW FZA	6	11
34	ALL RTW	2R-200562	GUARD, FAN - WIRE	2	11
35	ALL RTW	2E-Z20780	POWER SUPPLY 24VDC 10W	1	11,12
36	RTW14EA	2U-200559	MOTOR,FAN 120V 23BTM	1	11,12
	RTW14EA	2U-200561	MOTOR,FAN208-240V 23BTM		
	RTW19EA				
37	ALL RTW	D6-Z22634-1	COVER,TOP,REAR,PEM	1	11,12
38	ALL RTW	2I-Z0057	FOOT, RUBBER	2	11
39	ALL RTW	2C-3033	SCREW-MACH8-32X3/4 THP SS	2	11
40	ALL RTW	2C-Y6138	RIVET 1/8X.250 POP SS SM	14	11
41	ALL RTW	2M-Z18710	NAMEPLATE, BLANK RTW	1	11
42	ALL RTW	2P-Z8478	HINGE	2	11
43	ALL RTW	2M-Z7207	STICKER, GROUND SYMBOL	1	11
44	ALL RTW	2C-35736	NUT 8-32 HEX KEPS MS GREEN	1	11
45	RTW14EA	D6-RTW085	ASSY,DRUM,SPROCKET,RTW-14	1	8
	RTW19EA	D6-RTW070	ASSY,DRUM,SPROCKET,RTW-19		
46	ALL RTW	2E-Z17513	POWER BOARD	1	11

NOTES:

WALL MOUNT INSTALLATION

LAG SCREWS MUST BE INSTALLED INTO STUDS FOR SUPPORT OF THE RTW UNIT. FAILURE TO INSTALL IN STUDS COULD RESULT IN DAMAGE TO UNIT AND/OR HARM TO PERSONS OR PROPERTY. STAR IS NOT RESPONSIBLE FOR DAMAGE RELATED TO INCORRECT INSTALLATION OR FAULTY CONSTRUCTION. THESE INSTRUCTIONS REFERENCE INSTALLATION SHEET NUMBER 2M-Z21299.

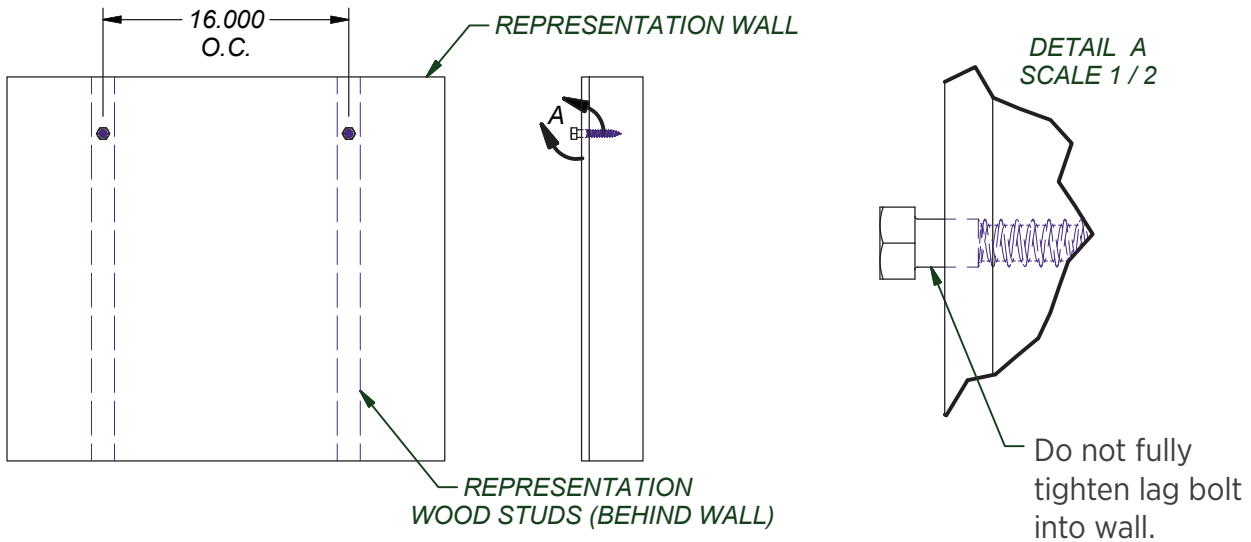

**STEP 1 - INSTALL LAG SCREWS (ITEM 1) INTO WALL
(SEE NOTE ON PAGE ***)**

- !!!!DO NOT TIGHTEN LAG BOT FULLY INTO WALL!!!
- MARK AND LOCATE CENTER OF WALL STUDS
- STANDARD CONSTRUCTION IS 16" ON CENTER (O.C.)

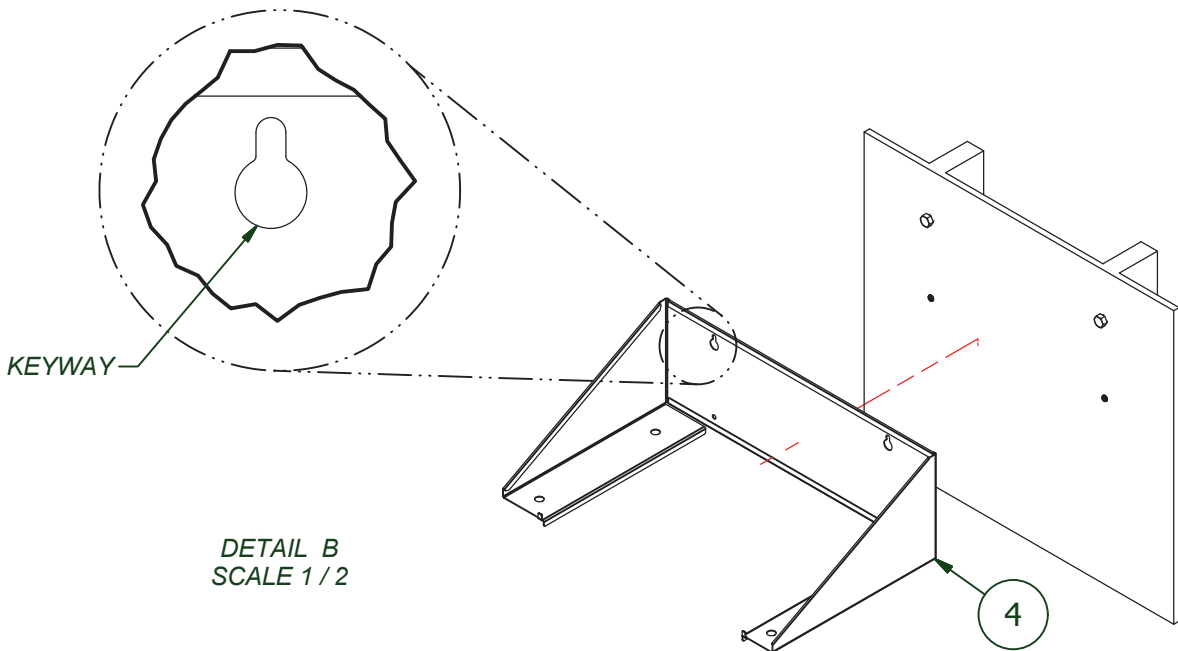

**STEP 2 - HANG RTW WALL MOUNT BRACKET (ITEM 4)
OVER LAG BOLTS-SLIDE DOWN INTO KEYWAY**

**STEP 3 - FINISH TIGHTENING DOWN LAG BOLTS
AND INSTALL TRUSS SCREWS (ITEM 2)
AS SHOWN.**

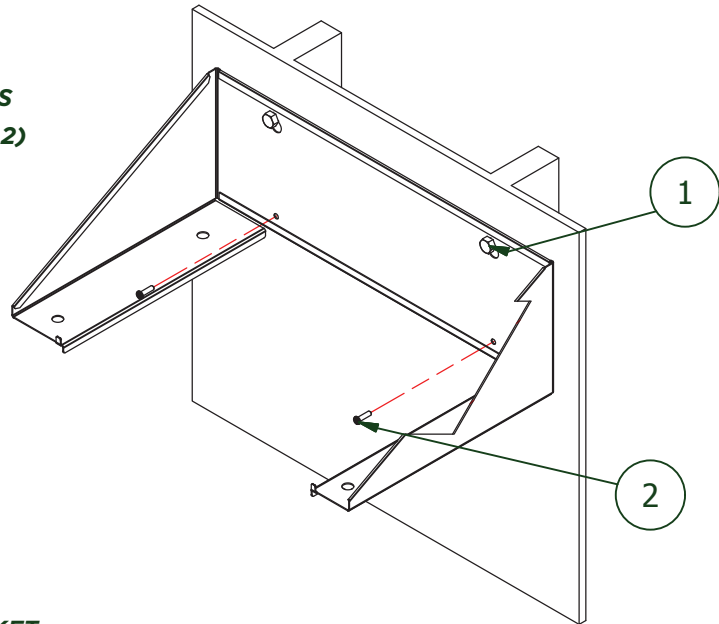

**STEP 4 - PLACE TORTILLA WARMER INTO BRACKET
ALIGN MOUNTING HOLES ON BOTTOM OF UNIT
WITH HOLES IN WALL MOUNT BRACKET.
SCREW IN BUTTON SOCKET SCREW(S) (ITEM 3)
AND TIGHTEN TO SECURE.**

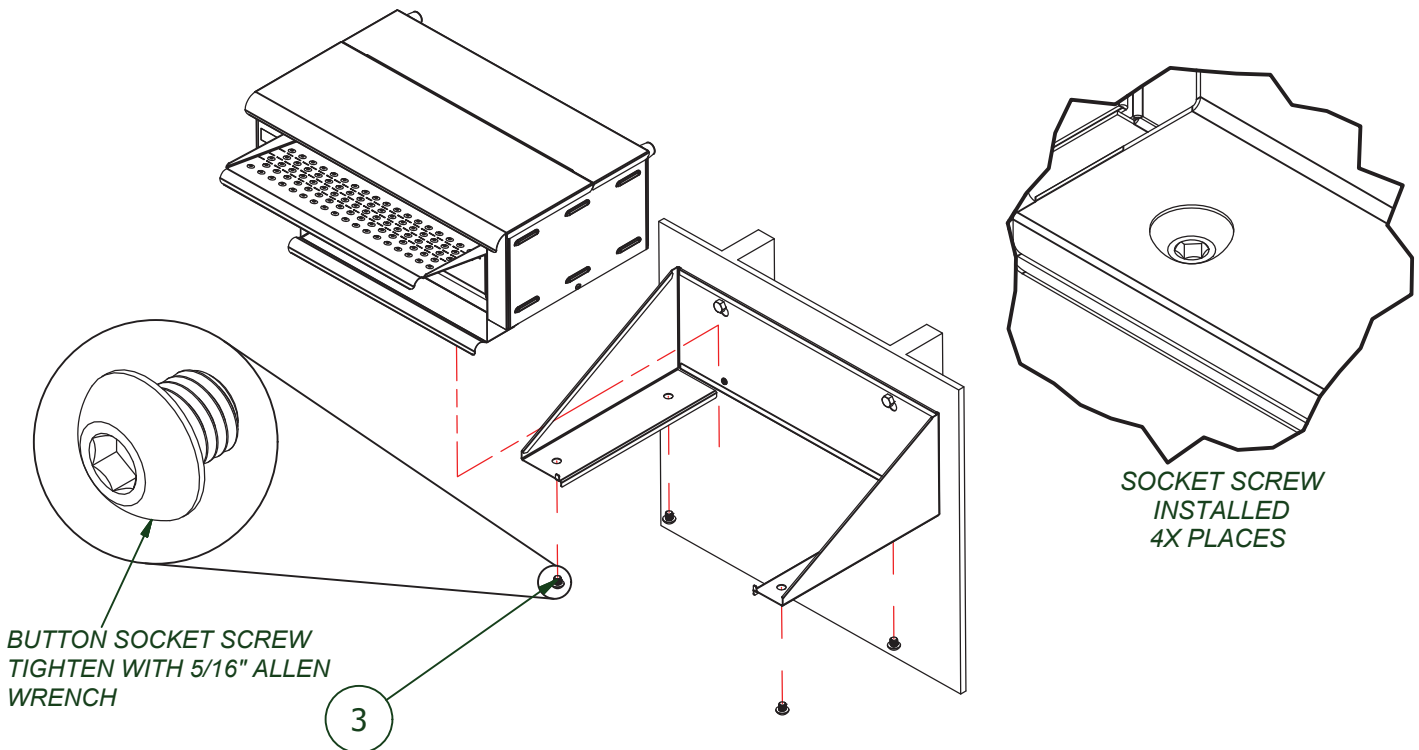

Wall Mount Parts List			
ITEM	P/N	TITLE	QTY
1	2C-Z21298	HEX LAG SCREW, 2-5/16 X 2" X 1/2" HEX SIZE	2
2	2C-Z21297	K-LATH SCREW, TRUSS, #8, 1"	2
3	2C-Z19191	BOLT 1/2-13x1/2 BHSC SS	4
4	D6-Z22669 D6-Z22668	BRACKET, WALL MOUNT, RTW19EA BRACKET, WALL MOUNT, RTW14EA	1



Rolling Tortilla Warmer

□RTW14EA □RTW19EA

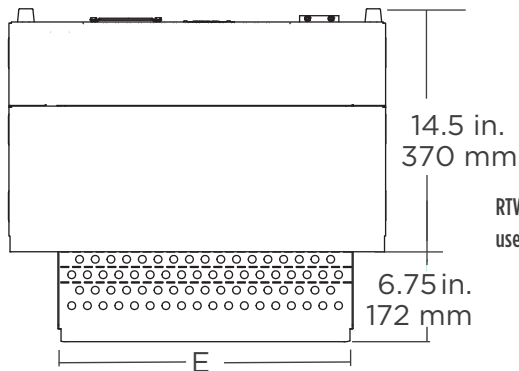

RTW19EA is the model used in these drawings.

CLEARANCES

Please allow at least ten [10] inches (254 mm) of space to open the top for cleaning if the unit is to remain stationary. There should be at least one [1] inch (25 mm) of clearance on each side and behind the unit as well.

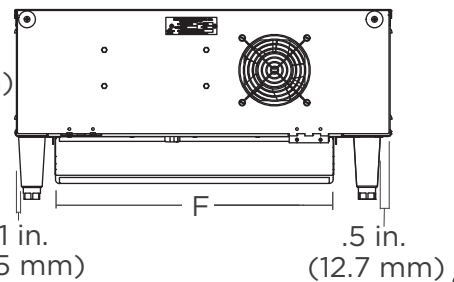
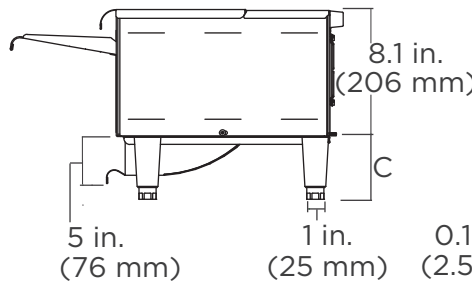
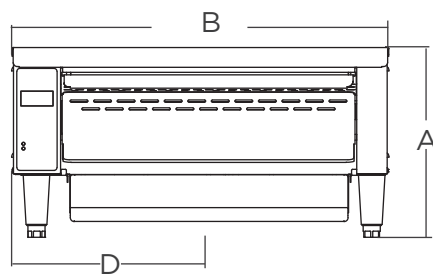

5-15P



5-20P



CH2-16P



6-15P

MODEL	HEIGHT [A] in. (mm)	WIDTH [B] in. (mm)	DEPTH in. (mm)	LEG HEIGHT [C] in. (mm)	VOLTS	AMPS	WATTS	POWER PLUG	APPROX. SHIP WEIGHT	APPROX. WEIGHT INSTALLED
RTW14EA ¹	13 (305)	19.6 (498)	21.3 (541)	5 (102)	120 208-240	14.9 6.3-7.2	1,787 1,351-1787	5-15P 6-15P	69 lb. (31.4 kg)	50 lb. (22.7 kg)
RTW19EA ¹	13 (305)	24.0 (610)	21.3 (541)	5 (102)	208-240	9.1-10.5	1905-2537	6-15P	77 lb. (35.0 kg)	62 lb. (28.1 kg)

MODEL	CORD DISTANCE FROM CONTROL SIDE [D]	CORD DISTANCE FROM CONTROL REAR	INLET TRAY WIDTH [E]	OUTPUT TRAY WIDTH [F]
RTW14EA ¹	12.2 in. (310 mm)	2.1 in (53 mm)	14.1 in. (358 mm)	13.0 in. (330 mm)
RTW19EA ¹	14.0 in. (356 mm)	2.1 in (53 mm)	18.9 in. (480 mm)	18.0 in. (457 mm)

¹ patent no. 9,516,883

Due to periodic changes in designs, methods, procedures, policies and regulations, the specifications contained in this sheet are subject to change without notice. While Star Manufacturing exercises good faith efforts to provide information that is accurate, we are not responsible for errors or omissions in information provided or conclusions reached as a result of using the specifications. By using the information provided, the user assumes all risks in connection with such use.



STAR MANUFACTURING INTERNATIONAL INC.

265 Hobson Street • Smithville, Tennessee 37166
Telephone 888 356 5362 • Fax 314 781 5445
www.star-mfg.com

Printed in the U.S.A. • 2M-Z21286 • Rev E • 08.2018
Please refer to the owner's manual for information regarding installation or use.

FACTORY SETTINGS ADJUSTMENT

- i. With the machine *OFF* hold the “SET/TEMP” and “▲/CLEAN” buttons.
- ii. While in this menu, the display alternately flashes a parameter and the current setting for that parameter.
- iii. Use the ▲ and ▼ buttons to adjust the current parameter, then press the “SET/TEMP” button to move to the next parameter. After moving through all parameters, “OFF” will once again appear on the screen.

DISPLAY READOUT	DEFAULT SETTING	DESCRIPTION	ADJUSTMENT
<i>MOTOR</i>	BDC	motor type [brushless DC motor]	
<i>DIR</i>	CCW	drum rotation direction	
<i>PPM</i>	8250	motor speed [pulse per minute]	0-15,000
<i>RATIO</i>	10	turn down ratio of the drum speed	1-60
<i>PREHT</i>	2	time the heat system pauses during preheat cycle [measured in minutes]	1-10
<i>OFFST</i>	0	offset added to raw drum temp for display	±200°F (±93°C)
<i>COOL</i>	30	cool down timer setting [measured in minutes]	0-60
<i>IRDRP</i>	20	percentage of set point temperature ¹	1-99
<i>IRRCV</i>	180	timer for IRDRP correction ²	30-300
<i>DIGIR</i>	YES	digital infra-red setting	YES/NO
<i>IRHPT</i>	18	preheat mode timer ³ [measured in minutes]	1-30

¹triggers the IRRCV timer when temperature is below this percentage of set point temperature

²if the IRDRP temperature is below the trigger point continuously for the entire time, it will trigger a “BAD PROBE” fault condition

³if the temperature is below 300°F when time limit is reached, a “BAD PROBE” fault condition will be active

STAR MANUFACTURING INTERNATIONAL INC.

265 Hobson St. Smithville, TN 37166
 Telephone 800 264 7827 • Fax 314 781 5445
 www.star-mfg.com

Printed in the U.S.A. • 2M-Z19213 • Rev H • 04.2019
 Specifications are subject to change without notice.