

Holman[®] **CONVEYOR SANDWICH TOASTER**

MODEL
QT14C, QT14CR

Installation and Operation Instructions

2M-Z10368 Rev. B 7/11/07

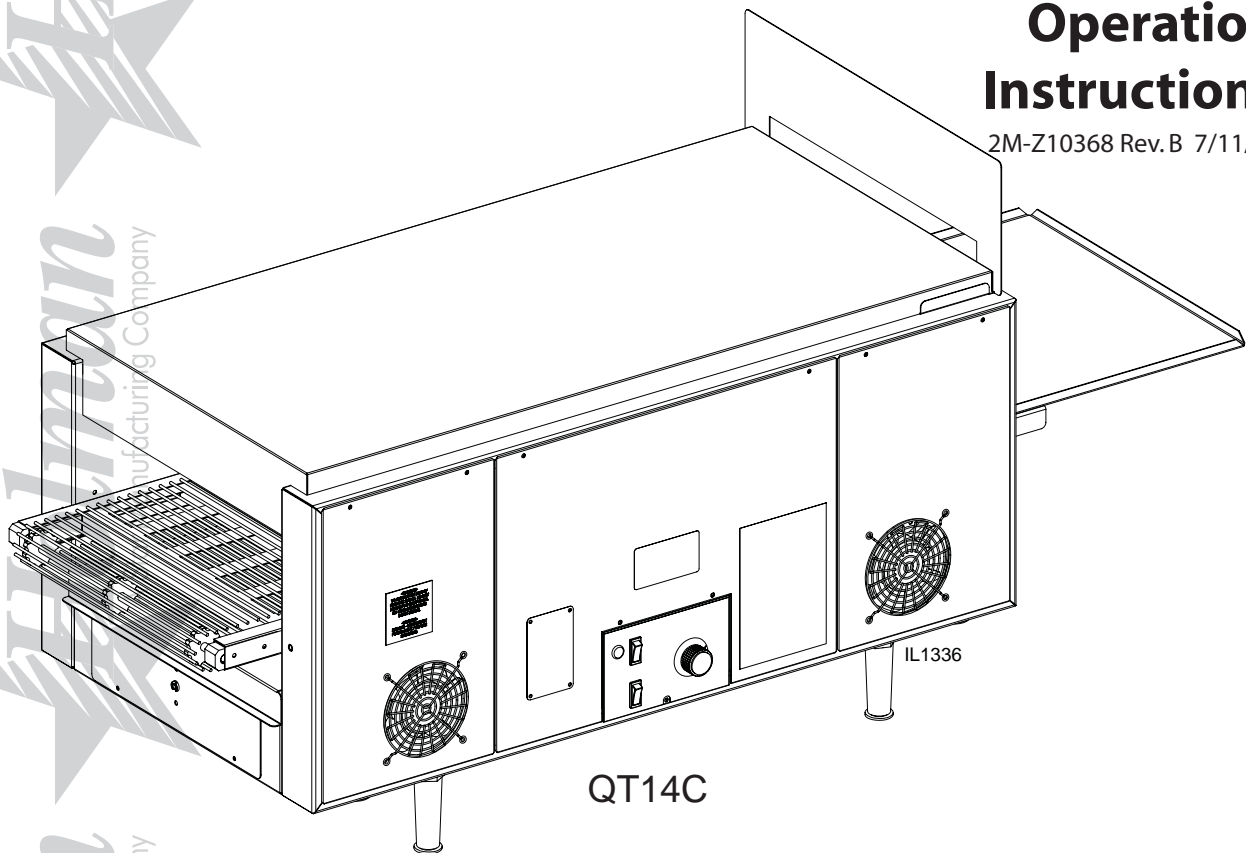

SAFETY SYMBOL



These symbols are intended to alert the user to the presence of important operating and maintenance instructions in the manual accompanying the appliance.

RETAIN THIS MANUAL FOR FUTURE REFERENCE NOTICE

Using any part other than genuine Star factory supplied parts relieves the manufacturer of all liability.

Star reserves the right to change specifications and product design without notice. Such revisions do not entitle the buyer to corresponding changes, improvements, additions or replacements for previously purchased equipment.

Due to periodic changes in designs, methods, procedures, policies and regulations, the specifications contained in this sheet are subject to change without notice. While Star Manufacturing exercises good faith efforts to provide information that is accurate, we are not responsible for errors or omissions in information provided or conclusions reached as a result of using the specifications. By using the information provided, the user assumes all risks in connection with such use.

MAINTENANCE AND REPAIRS

Contact your local authorized service agent for service or required maintenance. Please record the model number, serial number, voltage and purchase date in the area below and have it ready when you call to ensure faster service.

Model No. _____
Serial No. _____
Voltage _____
Purchase Date _____

Authorized Service Agent

Reference the listing provided with the unit

OR

for an updated listing go to:

Website: www.star-mfg.com
E-mail Service@star-mfg.com
Telephone: (800) 807-9054 Local (314) 781-2777

The Star Service Help Desk

Business Hours: 8:00 am to 4:30 p.m. Central Standard Time

Telephone: (800) 807-9054 Local (314) 781-2777

Fax: (800) 396-2677 Local (314) 781-2714

E-mail Parts@star-mfg.com
Service@star-mfg.com
Warranty@star-mfg.com

Website: www.star-mfg.com

Mailing Address: Star Manufacturing International Inc.
10 Sunnen Drive
St. Louis, MO 63143
U.S.A

GENERAL INSTALLATION DATA



This equipment is designed and sold for commercial use only by personnel trained and experienced in its operation and is not sold for consumer use in and around the home nor for use directly by the general public in food service locations.

Before using your new equipment, read and understand all the instructions & labels associated with the unit prior to putting it into operation. Make sure all people associated with its use understand the units operation & safety before they use the unit.

INSPECTION & ASSEMBLY

All shipping containers should be checked for freight damage both visible and concealed. This unit has been tested and carefully packaged to insure delivery of your unit in perfect condition. If equipment is received in damaged condition, either apparent or concealed, a claim must be made with the delivering carrier.

Concealed damage or loss - if damage or loss is not apparent until after equipment is unpacked, a request for inspection of concealed damage must be made with carrier within 15 days. Be certain to retain all contents plus external and internal packaging materials for inspection. The carrier will make an inspection and will supply necessary claim forms.

UN CRATING AND INSPECTING

Unpack the unit and components from the shipping container. Remove all visible packing material. If damage is discovered, file a claim immediately with the carrier that handled the shipment. **DO NOT** operate the unit if it was damaged during shipping.

The following should be included: Holman Conveyor Sandwich Toaster, Stainless Steel Unload Tray, (four) 4 Stainless Steel Legs, 2 crumb trays, extra Motor, and Magnetic Bake Aid w/Bracket.

ASSEMBLY AND INSTALLATION

The unit was shipped with certain assembly required.

To attach the four 4 legs, with assistance place the unit on its end as shown (damage to the controls can occur when the unit is placed on the control side) insert the legs by screwing them into the weld nuts located on the bottom of the unit. When completed and with help, carefully turn the unit upright.

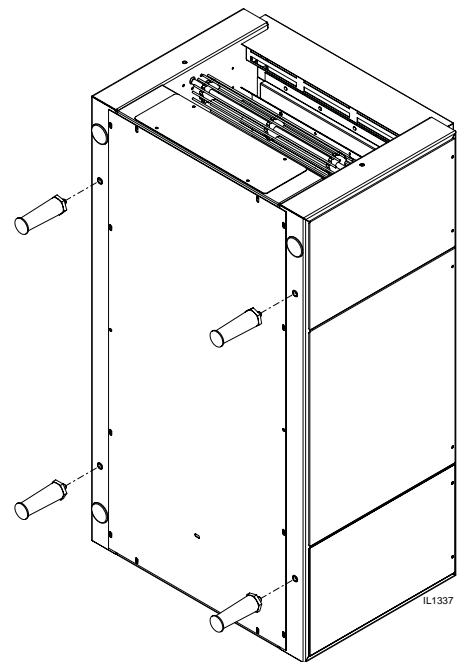

NEVER OPERATE UNIT WITHOUT PROPER LEGS IN PLACE.

Install unit in its operating position. Level unit by adjusting the feet. Both ends must be at least 6" from any vertical combustible surface. Allow sufficient space for operating personnel.

The Unload Tray has a keyhole slot on the tray that will slide over the two screw heads on the end of the toaster as shown in the Toaster Components Illustration.

The crumb tray slides into each end of the toaster under the conveyor. They keep the interior of the machine clean and reflect heat away from the controls and back up to the sandwiches. A layer of aluminum foil on the tray (check that it does not interfere with the conveyor) will make the tray more reflective and make cleanup easier.



ASSEMBLY AND INSTALLATION continued

ELECTRICAL CONNECTION

Have an electrician connect input power to the unit(s) in accordance with local electrical codes. **CORD & PLUG IS PROVIDED.**

VERIFY THE GROUND (EARTH) CONNECTION IS PROPERLY WIRED. NEVER CONNECT UNIT TO POWER WITHOUT PROPER GROUND CONNECTIONS. IMPROPER GROUND MAY RESULT IN SEVERE INJURY OR FATALITY.



WARNING MAKE SURE ALL INPUT POWER IS OFF BEFORE INSTALLING/REMOVING ANY PARTS.

BEFORE INSTALLING UNIT, HAVE YOUR ELECTRICIAN CHECK WITH LOCAL POWER COMPANY TO DETERMINE ACTUAL VOLTAGE AT THE STORE.

Before applying input power to the unit, check elements for damage. **DO NOT** apply power to the unit if a any elements are damaged. If elements are in good condition, apply input power by switching the ON/OFF toggle to the ON position. Turn conveyor belt speed control to the maximum setting and check all elements and conveyor for proper operation.

Allow approximately 5 to 10 minutes for the twin-fan cooling system to come on. Check the air intake fan area shown below, making sure there is a sufficient flow of air into the unit. Restricting the airflow will cause the unit to run hotter then designed causing damage to the unit.

If all heater and conveyor systems are operating properly, turn the master ON/OFF switch to the OFF position and allow unit to cool. The fans will continue to circulate cool air throughout the unit until the internal temperatures have been decreased.

If a problem is discovered during start up procedures, immediately turn the Master ON/OFF switch to the OFF position and call the Star Service Help Desk at 1-800-807-9054.

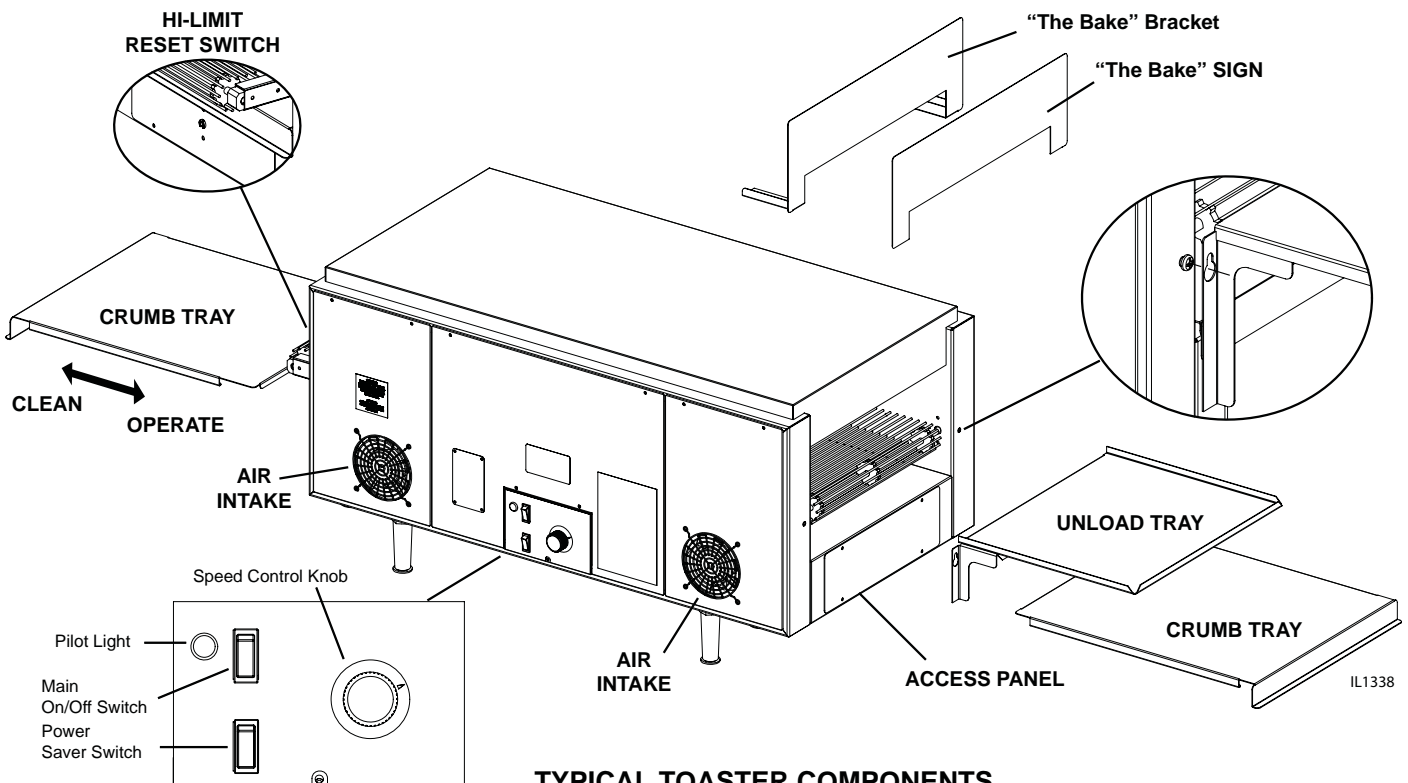

TYPICAL TOASTER COMPONENTS

CONTROL PANEL CONTROLS

STACKING TOASTERS

When stacking two Holman QT14/QT14C Conveyor Sandwich Toasters a QT14 Stacking Legs Kit (part no. PS-Z8977) **MUST** be used to prevent overheating of the control box of the top toaster.

1. Unplug **BOTH UNIT** power cords from the wall receptacle, and allow to cool.
2. Once cooled, stand the top unit on end and remove all 4 feet.
Save them for possible future use.
3. Take one of the four (4) stacking legs and bolt it in place of previously removed leg. Tighten using wrench. Install the remaining three.
4. Stand unit in its usable position and verify the legs are stable.

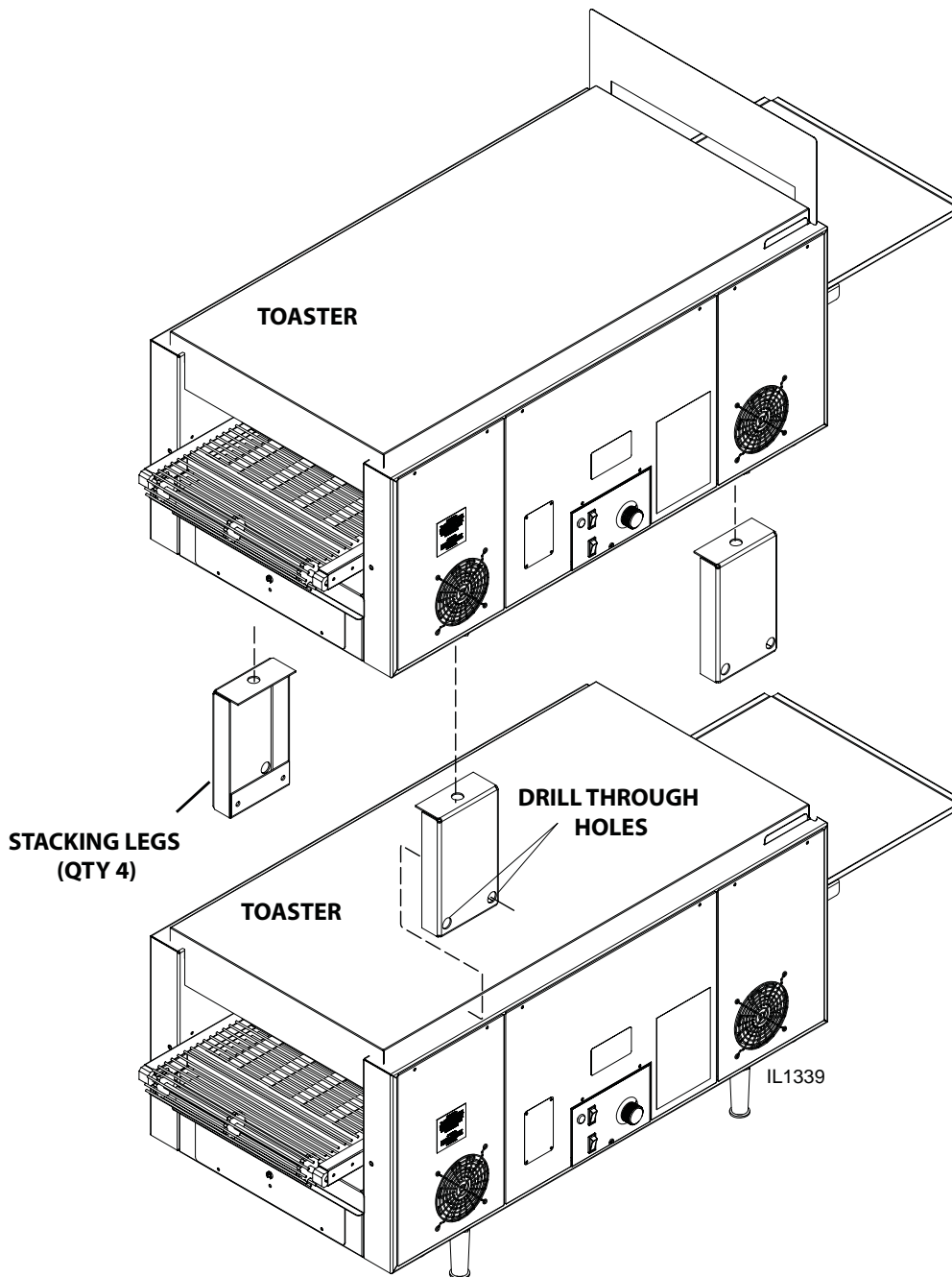

5. Place the upper unit on top of the other toaster, with the controls facing the same direction and lined up together.
6. Once in place, using a #29-drill bit (.136"), drill holes into the lower toaster by going through the drill holes in the stacking leg as shown. Do this in all four (4) places.
7. Insert screws (provided) into the mounting holes securing the two units together. Continue until all four (4) are complete.
8. Plug in units and test for proper operation.

DAILY OPERATION

1. Turn Main On/Off switch to the ON position and variable speed control to the desired setting. **Allow 30-40 minutes for complete machine warm up.**
2. Adjust speed as required during operation to achieve a good bake.
3. When done for the day, turn the On/Off switch to the OFF position. The conveyor will stop and the elements will go off. The two fans will continue to run to cool the machine. The fans are controlled by a thermostat and will stop when the elements are cooled.

POWER SAVER MODE:

During slow periods, switch the unit into the Power Saver Mode by turning ON the Power Saver Switch. Doing this will reduce the units power consumption by approx. 37%. In the power save mode elements 3,4,7 and 8 on the bottom and elements 3 and 4 on the top are operating. To ensure that you still provide a good bake it is essential to reduce the Speed Control to compensate for the reduction in power. You will still be able to provide a toast in 2 minutes in the power saver mode.

Allow 3 minutes for the unit to reach 100% power when turning off the power saver switch, before increasing the speed control back to its original position.

DO NOT begin to service or clean the machine until the fans have stopped.

CAUTION: Some parts of the machine will still be warm.

Refer to the Troubleshooting section if the machine is not performing as expected.

CERTAIN SURFACES ARE EXTREMELY HOT DURING OPERATION AND CARE SHOULD BE TAKEN WHILE USING THIS UNIT.

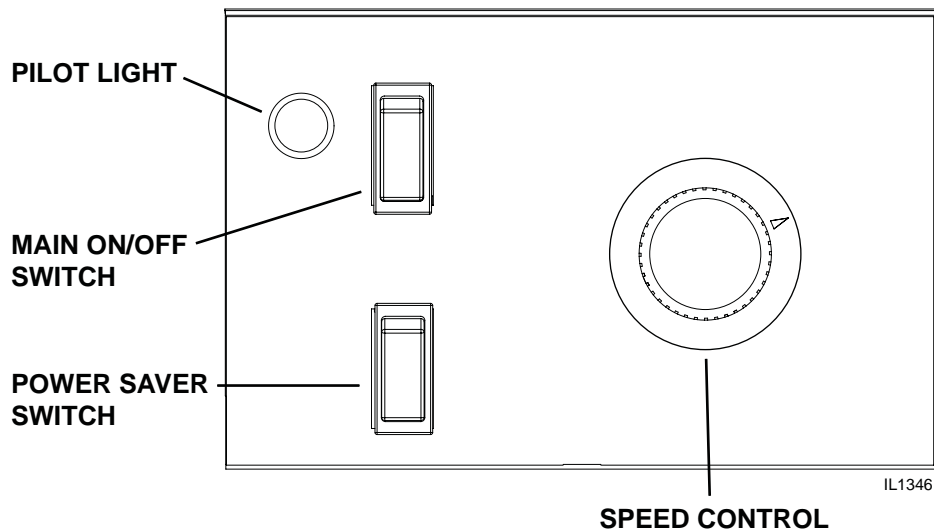

CLEANING

Preventive maintenance for your toaster consists of the following recommended cleaning procedures. To keep your unit in its top operating condition, these steps should be performed on a daily, weekly or as indicated.

Turn power off and allow cooling fans to run until the control box is cooled off. A thermostat in the control box controls the fans.



WARNING

DISCONNECT UNIT FROM POWER SUPPLY OR TURN POWER OFF AT WALL BREAKER.

DAILY

1. Turn main power switch to the OFF position, allow cooling fans to run until the control box is cooled off. Disconnect unit from power source and allow to cool.
2. Using a mild detergent, wipe exterior surfaces, clean with a damp cloth.
 - a. For lightly soiled build-up, clean with a damp cloth.
 - b. For heavily soiled build-up, use a soft damp cloth and mild detergent.**DO NOT use caustic cleaners.**
3. Remove the unload tray by lifting it out of position. Clean using mild detergent and warm water.
4. Remove all both crumb trays.
Clean crumb trays by wiping with a damp cloth and mild detergent.
DO NOT use caustic cleaners.
Place trays back in place prior to putting unit back into operation.
5. Check air intake area for dust and grease. To clean, vacuum and wipe with a dry cloth. (daily) **DO NOT** spray cleaning fluids into the air intake or cooking chamber. This may result in component failure.
6. Reconnect power.

CLEANING continued

WEEKLY

1. Turn main power switch to the OFF position, allow cooling fans to run until the control box is cooled off. Disconnect unit from power source and allow to cool.
2. Perform daily cleaning procedures.
3. Using a damp cloth, wipe clean the fan guard located on the control box cover under the unit.

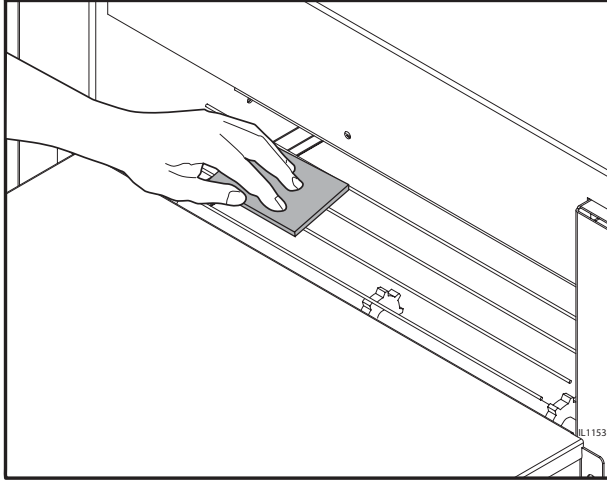

CLEANING CONVEYOR BELT

CONVEYOR BELT CLEANING PROCEDURES

4. Reconnect power or turn power back on.
5. Switch the ON/OFF switch to the ON position, and turn conveyor to its fastest setting.
6. With the conveyor turned on and the crumb trays in place, take a wire grill brush or dry abrasive pad, clean the exposed surface of conveyor belt by passing the brush or pad, back and forth across the surface of the conveyor belt as the belt moves past. Continue until the entire belt is clean. Make sure the crumb tray is installed; this will minimize the amount of particles that fall into the toaster.
7. When the Conveyor Belt is clean, take a damp cloth and wipe the conveyor, removing any loose particles on the belt surface. Turn Conveyor OFF.
8. Remove the Crumb Trays by sliding out from beneath the conveyor belt and discard soiled aluminum foil. If cleaning is necessary, use a damp cloth and mild detergent. **DO NOT** use caustic cleaners. **DO NOT RUN CONVEYOR OVEN WITHOUT CRUMB TRAYS INSTALLED.**
9. Cover crumb trays with clean aluminum foil and put back to its correct position.



WARNING

DO NOT IMMERSE OR LET THE UNIT STAND IN WATER.

DO NOT HOSE DOWN THE UNIT OR THE TABLE/COUNTER IF THE UNIT IS ON THE TABLE/COUNTER.

KEEP AWAY FROM RUNNING WATER.

CLEANING continued

MONTHLY

1. Turn main power switch to the OFF position, allow cooling fans to run until the control box is cooled off. Disconnect unit from power source and allow to cool.
2. Perform daily & weekly cleaning procedures.
3. Working from the power supply side of the oven, locate the side panel, remove two screws holding panel in place and remove panel. Drive chain is now exposed.
4. Check drive chain tension.

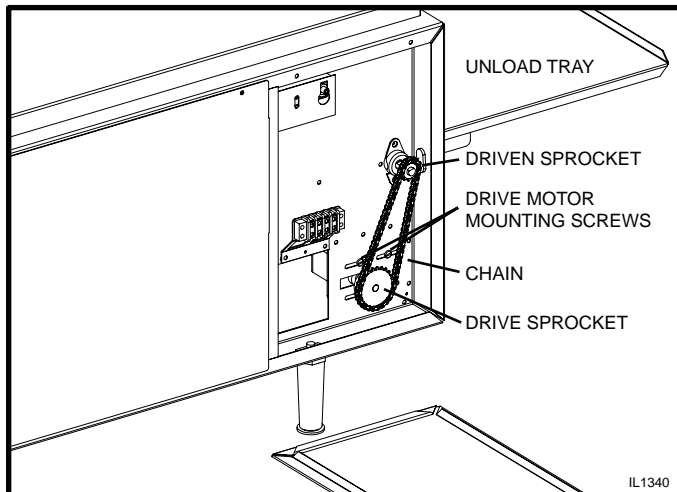

- a. When properly adjusted, chain will have about $\frac{1}{8}$ " play but will not sag. See *Chain Tension Illustration on page 12*.
- b. To adjust drive chain tension, locate the drive motor mounting screws (see illustration). Loosen screws holding drive motor in place and slide drive motor forward or backward to adjust chain tension. With proper chain tension, retighten motor screws.
- c. Following the procedures on page 12, Lubricate drive chain and sprocket teeth with a high temp lubricant part no. **1P-Z8914**.



5. Clean air intake on the side of the unit by vacuuming any dust and debris built up on the fan grill.
6. Remove screws holding the control side panels in place (as shown below). Carefully lift panel up and out. Vacuum any dust and debris from inside the unit, being sure to clean the fan blades and inside of unit, repeat opposite side.
7. Replace all panels when completed. **CHECK NO WIRES GET PINCHED AS THE PANELS ARE REPLACED. ALSO, CHECK ANY WIRES AROUND THE MOTOR TO MAKE SURE THEY DO NOT INTERFERE WITH THE SPROCKETS.**
8. For exterior portions of unit that are heavily soiled, an abrasive pad may be used for cleaning. Be sure to pass the pad in the direction of the grain in the metal to maintain the surface's finish. Lightly soiled surfaces may be cleaned with a damp cloth and mild cleaner.

9. Reconnect unit to power supply and test for proper operation.

**IF ASSISTANCE
IS REQUIRED, CALL THE
STAR SERVICE HELP DESK
AT 1-800-807-9054.**

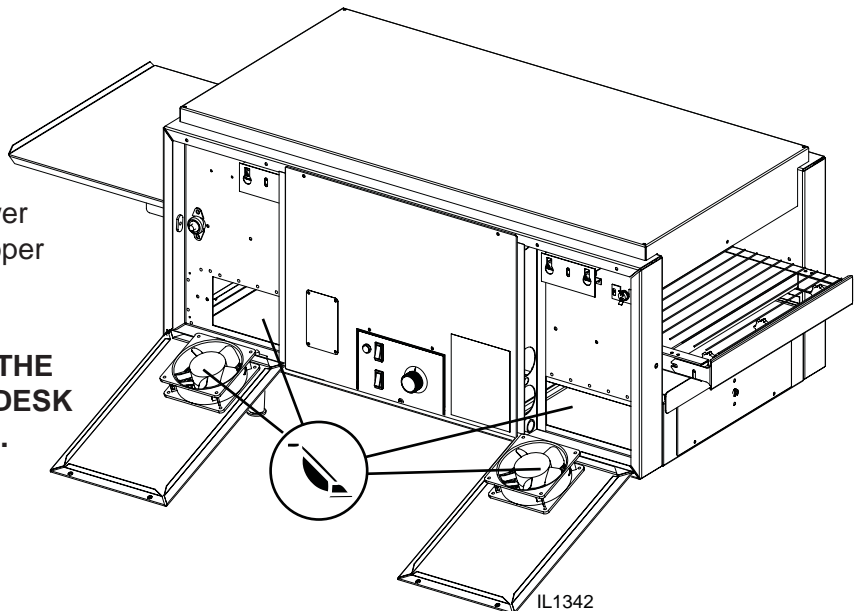

MAINTENANCE & REPAIRS

A. REPLACING ELEMENT

NOTE: Replace one element at a time.

- 1) **DISCONNECT POWER SOURCE.**
- 2) Remove both the left and right side panels, by removing the truss head screws. Pull the top of each panel out slightly and lift up.
- 3) Remove the wire terminal from the each end of the element you are replacing.
- 4) Remove the screws holding the Element Retainer and let it hang.
- 5) Gently, pull defective element out of unit.
- 6) Guiding the new element into position.
- 7) Thread wire through the specific hole in the element retainer & reconnect the wires to its previous position, lightly tug on the wire to ensure a good connection.
- 8) Reinstall the retainer to secure the element in place.
- 9) Install each side panel
- 10) Connect unit to power source and test unit for proper operation.

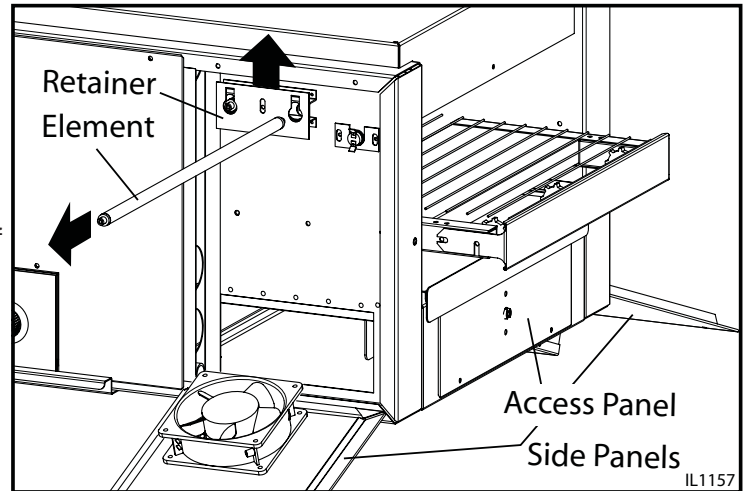

B. REPLACING FAN MOTOR

- 1) **DISCONNECT POWER SOURCE.**
- 2) Remove the side panel with the fan that needs replaced.
- 3) Unplug power supply cord from fan motor.
- 4) Remove (4) screws, which hold fan motor and grill to the side panel and remove fan.
- 5) Put replacement motor and grill in place and secure to the side panel with screws previously removed.
- 6) Reconnect power supply cord to fan motor.
- 7) Replace back panel and enclosure. Fasten with screws removed in step 2, being sure to keep wires away from the fan motor.
- 8) Connect unit to power source and test unit for proper operation.

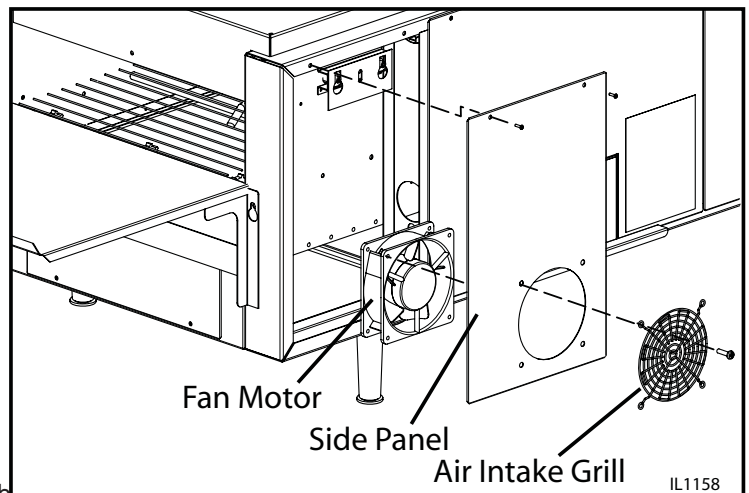

C. REPLACING BELT DRIVE MOTOR

- 1) **DISCONNECT POWER SOURCE.**
 - 2) Remove the side panel & access panel exposing the drive chain, sprockets & drive motor
 - 3) Remove sprocket from motor shaft, using an Allen wrench and loosening the set-screw.
 - 4) Disconnect the wires from terminal connecting the drive motor.
- Note** how the old motor is wired for replacement. For reference, use the black and white wires for 208V units and the black and blue wires for 240V units. The unused wire should be taped on the end and bundled with the existing wires so it will not get tangled in any moving parts.

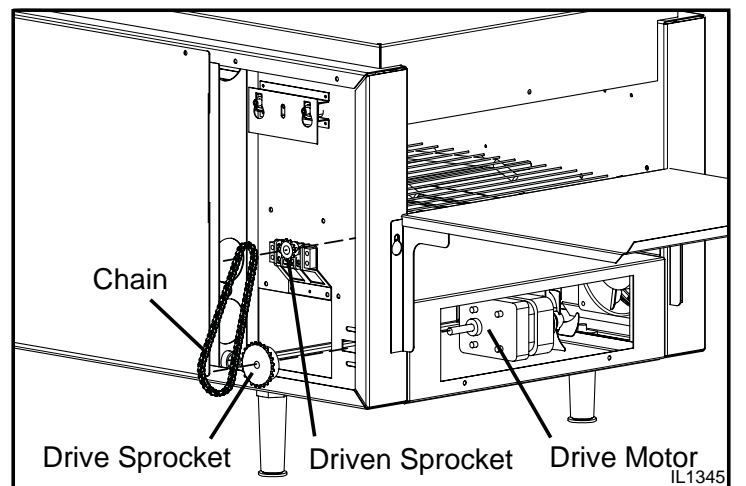

- 5) Remove screws holding motor in place and remove motor from unit.
- 6) Install the new motor in place and attach loosely with mounting screws.

MAINTENANCE PROCEDURES continued

- 7) Install sprocket on motor shaft & chain after aligning them.
See *Sprocket Alignment Illustration*.

NOTE: The two sprockets must line up FLUSH with each other, so the chain does not twist during operation. Also the hub is installed closest to the motor.

- 8) Slide motor until the drive chain has about 1/4" slack when lightly pushed at the center of its top open run.
See *Chain Tension Illustration*.
- 9) Tighten screws to secure motor.
- 10) Rewire leads same as removed in step 4.
- 11) At this time you may plug unit in and test for proper operation prior to reinstalling previously removed panels.
- 12) If unit is working correctly, turn unit off and unplug until completed
- 13) Reinstall side & access panels.
Reinstall the crumb trays.
- 14) Connect unit to power source and test again for proper operation.

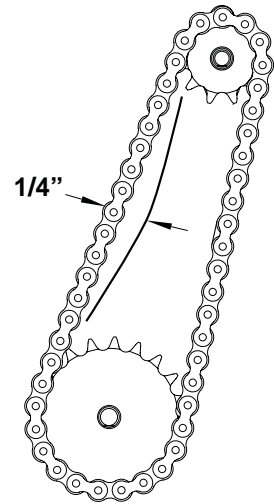

CHAIN TENSION

D. LUBRICATE THE CHAIN & SPROCKETS EVERY 6 MONTHS

- 1) **DISCONNECT UNIT FROM POWER SOURCE.**
- 2) Remove the side panels which exposes chain drive.
- 3) Check for proper Chain Tension, See *Chain Tension Illustration*.
- 4) Using an extreme pressure, synthetic chain lubricant with a temperature range up to 400°F.
Apply liberally onto chain and sprockets.
This grease is available separately as part no. **1P-Z8914**.

Call 1-(800) 807-9054 to order.

- 5) Replace side panels, Reconnect power source and test unit.

E. REPLACING SPEED CONTROL

- 1) **DISCONNECT POWER SOURCE.**
- 2) Remove the speed control knob and the locking nut holding the speed control in place.
- 3) Remove side panel, by removing the truss head screws. Pull the top of the panel out slightly and lift up.
- 4) Remove the wires from the control and insert wires for the new speed control into the same positions as shown on the wiring diagram.
- 5) Install the washer onto the shaft of the new speed control, followed by the installation.
- 6) When mounting the speed control in the side panel be sure to position the anti-rotation pin in the slot as shown.
- 7) Tighten the speed control assembly by using the locking nut, followed by the control knob.
- 8) Reinstall the side panel and tighten with the screws previously removed.
- 9) Connect unit to power source and test unit for proper operation.

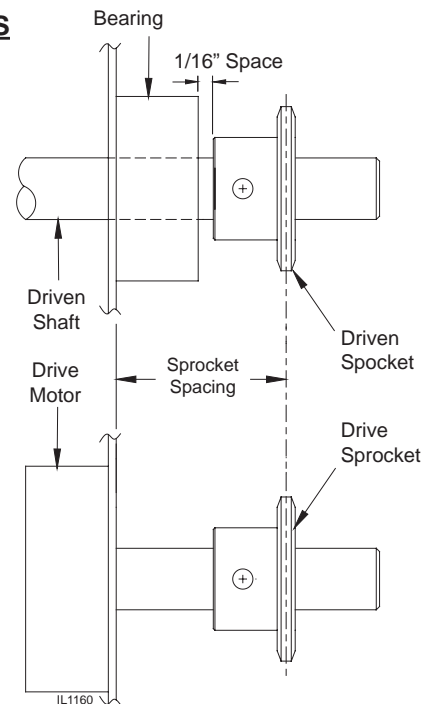

SPROCKET ALIGNMENT

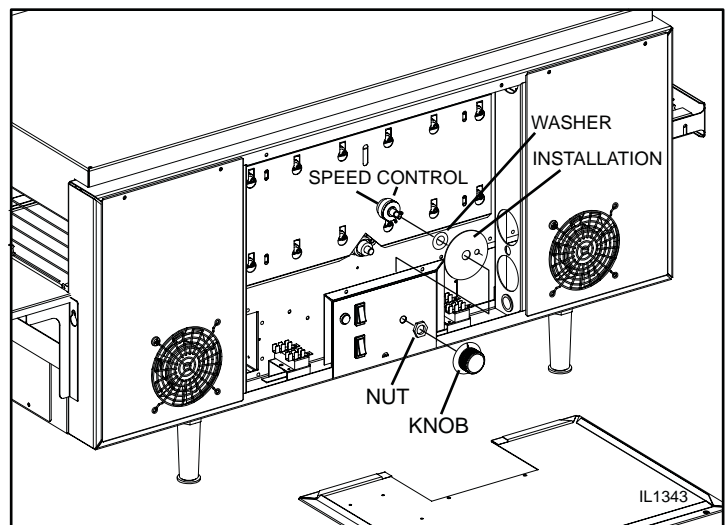

REPLACING SPEED CONTROL

TROUBLESHOOTING GUIDE

A. UNIT WILL NOT HEAT, CONVEYOR BELT WILL NOT MOVE.

- 1) Be sure the main circuit breaker is switched to the ON position and there is power to the outlet.
- 2) Check to see if the toaster is plugged in and all controls are turned to the ON position.
- 3) Be sure the Hi-Limit Reset Button is pushed in.
- 4) Call the Star Service Help Desk at 1-800-807-9054.

B. UNIT WILL NOT HEAT, CONVEYOR TURNS PROPERLY.

- 1) Press the Hi-Limit Reset Button located on the end under the conveyor belt.
If this reactivates the heater tubes, see Hi-Limit Reset Section below.
- 2) Call the Star Service Help Desk at 1-800-807-9054.

C. HI-LIMIT (HEAT) RESET.

Your Holman conveyor toaster is equipped with an automatic activated temperature limit switch which interrupts the heater tube connections if the air temperature in the control box exceeds 190°F (88°C). This limit switch can be reset manually by pushing the button in the center of the switch which is located on the right side under the conveyor belt. See Oven Components on Page 7 for location. Unit will not reset until internal temperature has fallen below 190°F (88°C).

NOTE: THE HI-LIMIT SWITCH CAN BE ACTIVATED IF THERE IS NOT A PROPER AMOUNT OF AIR FLOW BEING GENERATED BY THE COOLING FAN. IF THIS OCCURS:

- 1) **DISCONNECT UNIT FROM POWER SOURCE.**
- 2) Check to see if the air intake area is free of dust, grease or other obstructions.
- 3) Check to see if crumb trays (heat reflectors) are in place.
If the Hi-Limit Switch can not be reset, call the Star Service Help Desk at 1-800-807-9054.



NEVER OPERATE UNIT WITHOUT CRUMB TRAYS IN POSITION AS THIS CAN CAUSE OVERHEATING.

D. CONVEYOR WILL NOT TURN, UNIT HEATS PROPERLY.

To check for mechanical binding:

- 1) **DISCONNECT UNIT FROM POWER SOURCE.**
- 2) Check to see if there are obstructions in the conveyor system that may cause a jam. If so, remove obstruction.
- 3) Check power supply & terminal blocks for loose or disconnected wires.
- 4) Check to see if the two sprockets are properly aligned. Refer to **SPROCKET ALIGNMENT** previous section.
- 5) Remove side panel exposing the drive motor sprockets, see illustration. Manually move conveyor belt to check for mechanical binding. If conveyor belt moves freely, call the Star Service Help Desk at 1-800-807-9054. The drive motor or speed control may have to be replaced.

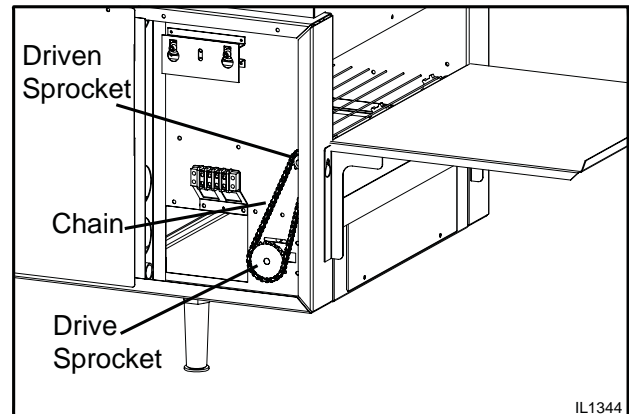

E. COOLING FAN DOES NOT START

- 1) Check fan blade for obstruction, or broken blades.
- 2) Check electrical connections are secure and complete & the Hi-Limit Switch is working properly.
- 3) If only one of the two fans are working, and all connections are good, replace the fan.
Refer to **REPLACING FAN MOTOR** in the previous section.
- 4) If both fans are not working, chances are the fan switch needs replacing.
- 3) Call the Star Service Help Desk at 1-800-807-9054, as the fan switch and or fan motor **MAY** need replacing.

Visit our Website at: www.star-mfg.com

Email: service@star-mfg.com

THOROUGHLY INSPECT YOUR UNIT ON ARRIVAL

This unit has been tested for proper operation before leaving our plant to insure delivery of your unit in perfect condition. However, there are instances in which the unit may be damaged in transit. In the event you discover any type of damage to your product upon receipt, you must immediately contact the transportation company who delivered the item to you and initiate your claim with same. If this procedure is not followed, it may affect the warranty status of the unit.

LIMITED EQUIPMENT WARRANTY

All workmanship and material in Star products have a one (1) year limited warranty on parts & labor in the United States and Canada. Such warranty is limited to the original purchaser only and shall be effective from the date the equipment is placed in service. Star's obligation under this warranty is limited to the repair of defects without charge, by the factory authorized service agency or one of its sub-agencies. Models that are considered portable (*see below*) should be taken to the closest Star service agency, transportation prepaid.

- > Star will not assume any responsibility for loss of revenue.
- > On all shipments outside the United States and Canada, see International Warranty.
- * The warranty period for the JetStar six (6) ounce & Super JetStar eight (8) ounce series popcorn machines is two (2) years.
- * The warranty period for the Chrome-Max Griddles is five (5) years on the griddle surface. See detailed warranty provided with unit.
- * The warranty period for Teflon/Dura-Tec coatings is one year under normal use and reasonable care. This warranty does not apply if damage occurs to Teflon/Dura-Tec coatings from improper cleaning, maintenance, use of metallic utensils, or abrasive cleaners, abrasive pads, product identifiers and point-of-sale attachments, or any other non-food object that comes in continuous contact with the roller coating. This warranty does not apply to the "non-stick" properties of such materials.
- > This warranty does not apply to "Special Products" but to regular catalog items only. Star's warranty on "Special Products" is six (6) months on parts and ninety (90) days on labor.
- > This warranty does not apply to any item that is disassembled or tampered with for any purpose other than repair by a Star Authorized Service Center or the Service Center's sub-agency.
- > This warranty does not apply if damage occurs from improper installation, misuse, wrong voltage, wrong gas or operated contrary to the Installation and Operating instructions.
- > This warranty is not valid on Conveyor Ovens *unless* a "start-up/check-out" has been performed by a Factory Authorized Technician.

PARTS WARRANTY

Parts that are sold to repair out of warranty equipment are warranted for ninety (90) days. The part only is warranted. Labor to replace the part is chargeable to the customer.

SERVICES NOT COVERED BY WARRANTY

1. Travel time and mileage rendered beyond the 50 mile radius limit
2. Mileage and travel time on portable equipment (*see below*)
3. Labor to replace such items that can be replaced easily during a daily cleaning routine, ie; removable kettles on fryers, knobs, grease drawers on griddles, etc.
4. Installation of equipment
5. Damages due to improper installation
6. Damages from abuse or misuse
7. Operated contrary to the Operating and Installation Instructions
8. Cleaning of equipment
9. Seasoning of griddle plates
10. Voltage conversions
11. Gas conversions
12. Pilot light adjustment
13. Miscellaneous adjustments
14. Thermostat calibration and by-pass adjustment
15. Resetting of circuit breakers or safety controls or reset buttons
16. Replacement of bulbs
17. Replacement of fuses
18. Repair of damage created during transit, delivery, & installation OR created by acts of God

PORTABLE EQUIPMENT

Star will not honor service bills that include travel time and mileage charges for servicing any products considered "Portable" including items listed below. These products should be taken to the Service Agency for repair:

- * The Model 510FD Fryer.
- * The Model 526TOA Toaster Oven.
- * The Model J4R, 4 oz. Popcorn Machine.
- * The Model 518CMA & 526CMA Cheese Melter.
- * The Model 12MC & 15MC & 18MCP Hot Food Merchandisers.
- * The Model 12NCPW & 15NCPW Nacho Chip/Popcorn Warmer.
- * All Hot Dog Equipment **except Roller Grills & Drawer Bun Warmers.**
- * All Nacho Cheese Warmers **except Model 11WLA Series Nacho Cheese Warmer.**
- * All Condiment Dispensers **except the Model HPD & SPD Series Dispenser.**
- * All Specialty Food Warmers **except Model 130R, 11RW Series, and 11WSA Series.**
- * All QCS/RCS Series Toasters **except Model QCS3 & RCS3 Series.**

ALL:

- * Pop-Up Toasters
- * Butter Dispensers
- * Pretzel Merchandisers
(Model 16PD-A Only)
- * Pastry Display Cabinets
- * Nacho Chip Merchandisers
- * Accessories of any kind
- * Sneeze Guards
- * Pizza Ovens
(Model PO12 Only)
- * Heat Lamps
- * Pumps-Manual

The foregoing warranty is in lieu of any and all other warranties expressed or implied and constitutes the entire warranty.

FOR ASSISTANCE

Should you need any assistance regarding the Operation or Maintenance of any Star equipment; write, phone, fax or email our Service Department. In all correspondence mention the Model number and the Serial number of your unit, and the voltage or type of gas you are using.

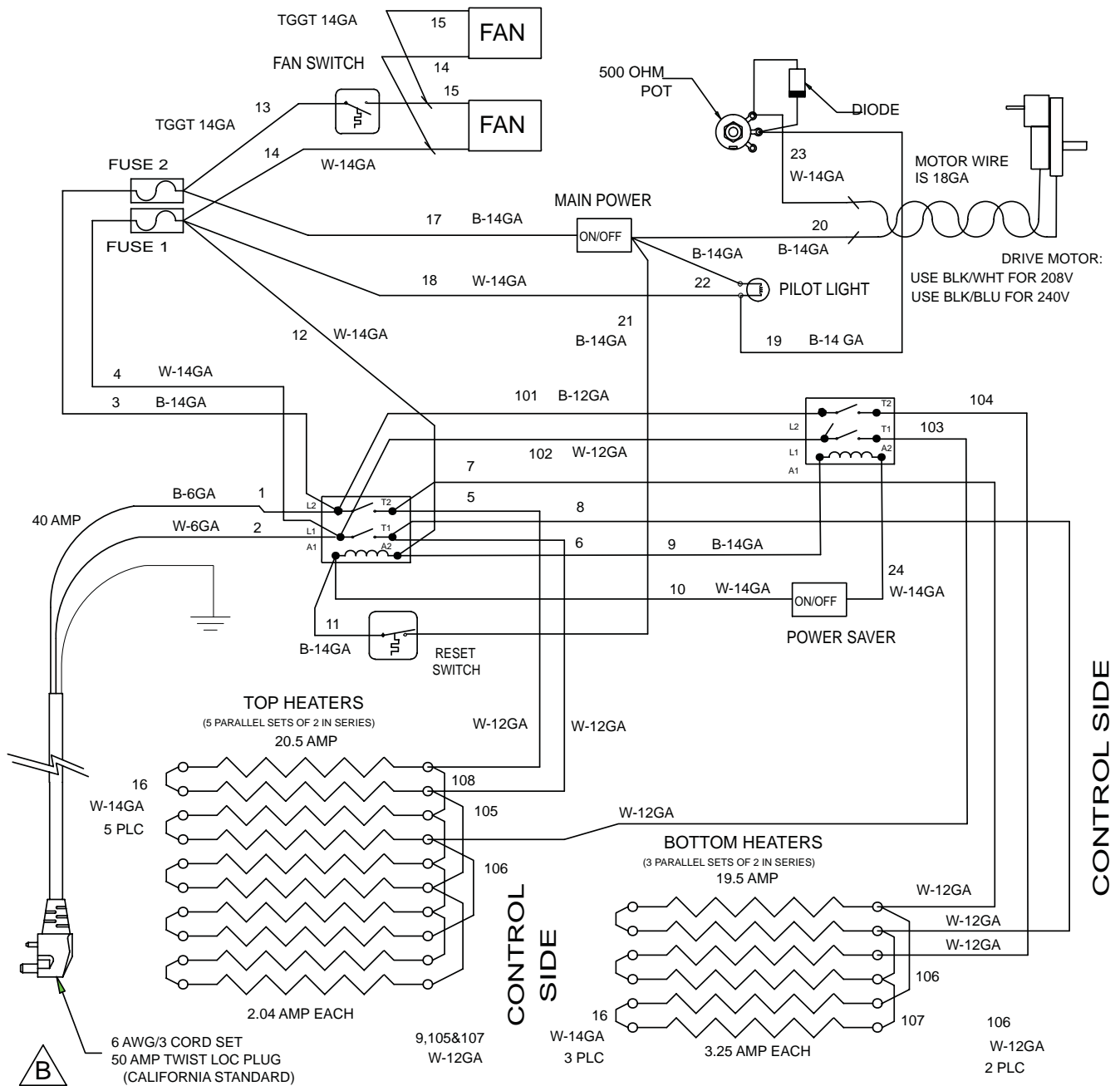

THIS DRAWING CONTAINS INFORMATION CONFIDENTIAL TO STAR MFG. INT'L. INC.
NO REPRODUCTION OR DISCLOSURE OF ITS CONTENTS IS PERMITTED.



MODEL: QT14C 208/220/240V, 1Phase
w/Potentiometer Speed Control

STAR MANUFACTURING INTERNATIONAL INC.

SK2220

Rev B

7/09/2007

STAR MANUFACTURING

10 Sunnen Drive, St. Louis, MO 63143 U.S.A.

(800) 807-9054 (314) 781-2777

Parts & Service (800) 807-9054

www.star-mfg.com