



**STAR<sup>®</sup>**  
**PIZZA**  
**OVEN**

MODEL  
PO12

**Installation and  
Operation  
Instructions**

2M-Y6059 Rev.C 2/1/06

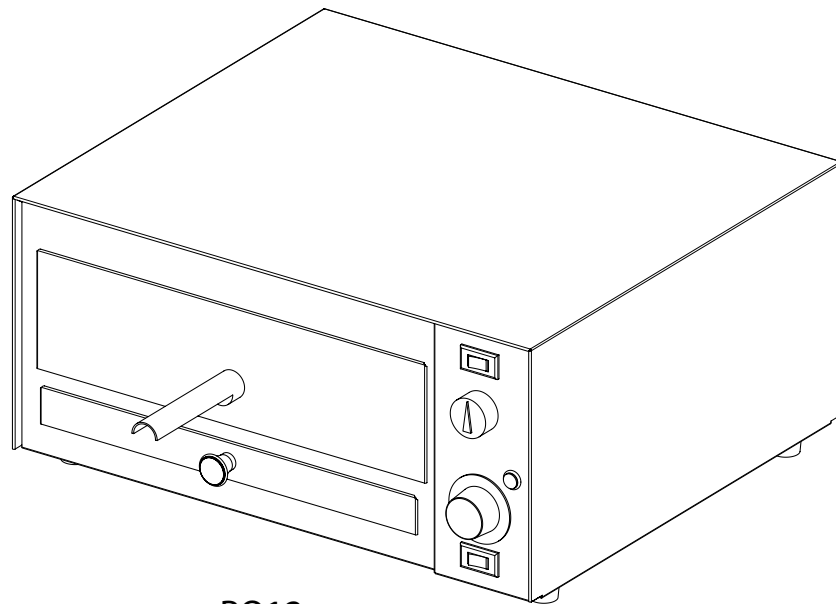

PO12



## SAFETY SYMBOL



These symbols are intended to alert the user to the presence of important operating and maintenance instructions in the manual accompanying the appliance.

---

## RETAIN THIS MANUAL FOR FUTURE REFERENCE NOTICE

Using any part other than genuine Star factory supplied parts relieves the manufacturer of all liability.

Star reserves the right to change specifications and product design without notice. Such revisions do not entitle the buyer to corresponding changes, improvements, additions or replacements for previously purchased equipment.

Due to periodic changes in designs, methods, procedures, policies and regulations, the specifications contained in this sheet are subject to change without notice. While Star Manufacturing exercises good faith efforts to provide information that is accurate, we are not responsible for errors or omissions in information provided or conclusions reached as a result of using the specifications. By using the information provided, the user assumes all risks in connection with such use.

## MAINTENANCE AND REPAIRS

Contact your local authorized service agent for service or required maintenance. Please record the model number, serial number, voltage and purchase date in the area below and have it ready when you call to ensure a faster service.

Model No. \_\_\_\_\_

Serial No. \_\_\_\_\_

Voltage \_\_\_\_\_

Purchase Date \_\_\_\_\_

### Authorized Service Agent

Reference the listing provided with the unit

or

for an updated listing go to:

**Website:** [www.star-mfg.com](http://www.star-mfg.com)  
**E-mail** [Service@star-mfg.com](mailto:Service@star-mfg.com)  
**Telephone:** (800) 807-9054 Local (314) 781-2777

### The Star Service Help Desk

**Business Hours:** 8:00 am to 4:30 p.m. Central Standard Time

**Telephone:** (800) 807-9054 Local (314) 781-2777

**Fax:** (800) 396-2677 Local (314) 781-2714

**E-mail** [Parts@star-mfg.com](mailto:Parts@star-mfg.com)  
[Service@star-mfg.com](mailto:Service@star-mfg.com)  
[Warranty@star-mfg.com](mailto:Warranty@star-mfg.com)

**Website:** [www.star-mfg.com](http://www.star-mfg.com)

**Mailing Address:** Star Manufacturing International Inc.  
10 Sunnen Drive  
St. Louis, MO 63143  
U.S.A

## GENERAL INFORMATION DATA



### CAUTION

This equipment is designed and sold for commercial use only by personnel trained and experienced in its operation and is not sold for consumer use in and around the home nor for use directly by the general public in food service locations. For equipment to be used by the general public, please contact the factory.

### VOLTAGE

This pizza oven is equipped for use on the voltage specified on the nameplate.



### WARNING

**DO NOT CONNECT TO ANY OTHER TYPE OF CURRENT OR THE MACHINE WILL BE SERIOUSLY DAMAGED.**

Before installation, place the oven in a convenient location for operation and maintenance. A minimum of 1/2" clearance is required on all sides for air circulation. The bumpers will keep the oven the proper distance from walls or surrounding equipment.

## INSTALLATION & OPERATION

For your protection, we recommend that a qualified electrician install this appliance. The electrician should be familiar with electrical installations and your local electrical requirements.

The oven should be placed on a horizontal surface only. Unpack the baking tray and slide it into the oven. The wire frame should slide inside the guide channels.

The oven features thermostatic control of the heating elements, On/Off switches for both upper and lower heating elements, and a 15 minute bell timer.

The adjustable thermostat provides various temperature settings (the range of temperatures is between 200° and 550° F). The main On/Off switch is incorporated in the thermostat.

A 15 minute mechanical bell timer signals when the preset time has been reached.

The pilot light indicates when the thermostat temperature has been reached.



### CAUTION

**DO NOT LEAVE THE OVEN UNATTENDED WHEN IN OPERATION. DO NOT USE THE TOP OF THE OVEN FOR STORAGE.**

## **BAKING PIZZA**

The oven can accommodate a 12" diameter pizza. Follow the food product instructions or set the thermostat to 450° F. After the oven is preheated, place the pizza on the baking tray. Cooking varies with the size and type of pizza. It will take approximately 8 minutes to bake a frozen pizza. A pizza should be baked until the cheese bubbles and the bottom is browned.

**NOTE: WHEN LOADING OR UNLOADING THE OVEN DO NOT KEEP THE DOOR OPEN TOO LONG. IT WILL LET HEAT ESCAPE AND EXTEND BAKING TIME.**

## **GENERAL BAKING**

The oven is designed for baking a variety of products. Fresh as well as frozen products may be cooked in the oven. Cooking time will vary with the size and the type of product.

## **CLEANING**

Keep the oven unit clean. Stainless steel, while corrosion resistant, should be cleaned daily. In general the outside surfaces of the oven require cleaning with a damp cloth and mild detergent.

Use a stainless steel cleaner for best results. When cleaning always try to wipe with the grain on the stainless steel surface. Do not use steel wool as fragments of the steel wool may get into the food. Follow these steps to clean the unit.

1. Turn thermostat to "Off" position.
2. Unplug the cord from the receptacle.
3. Remove the baking tray.
4. Remove the crumb pan.
5. **Once cooled**, Clean inside of the unit and wipe dry.
6. Clean the baking tray and the crumb pan and place back into the unit.

## **MAINTENANCE AND REPAIRS**

Contact the factory, a service representative or a local service company for service or required maintenance.

Visit our Website at: [www.star-mfg.com](http://www.star-mfg.com)

Email: [service@star-mfg.com](mailto:service@star-mfg.com)

### THOROUGHLY INSPECT YOUR UNIT ON ARRIVAL

This unit has been tested for proper operation before leaving our plant to insure delivery of your unit in perfect condition. However, there are instances in which the unit may be damaged in transit. In the event you discover any type of damage to your product upon receipt, you must immediately contact the transportation company who delivered the item to you and initiate your claim with same. If this procedure is not followed, it may affect the warranty status of the unit.

### LIMITED EQUIPMENT WARRANTY

All workmanship and material in Star products have a one (1) year limited warranty on parts & labor in the United States and Canada. Such warranty is limited to the original purchaser only and shall be effective from the date the equipment is placed in service. Star's obligation under this warranty is limited to the repair of defects without charge, by the factory authorized service agency or one of its sub-agencies. Models that are considered portable (*see below*) should be taken to the closest Star service agency, transportation prepaid.

- > Star will not assume any responsibility for loss of revenue.
- > On all shipments outside the United States and Canada, see International Warranty.
- \* The warranty period for the JetStar series six (6) ounce popcorn machines is two (2) years.
- \* The warranty period for the Chrome-Max Griddles is five (5) years on the griddle surface. See detailed warranty provided with unit.
- \* The warranty period for Teflon/Dura-Tec coatings is one year under normal use and reasonable care. This warranty does not apply if damage occurs to Teflon/Dura-Tec coatings from improper cleaning, maintenance, use of metallic utensils, or abrasive cleaners. This warranty does not apply to the "non-stick" properties of such materials.
- > This warranty does not apply to "Special Products" but to regular catalog items only. Star's warranty on "Special Products" is six (6) months on parts and ninety (90) days on labor.
- > This warranty does not apply to any item that is disassembled or tampered with for any purpose other than repair by a Star Authorized Service Center or the Service Center's sub-agency.
- > This warranty does not apply if damage occurs from improper installation, misuse, wrong voltage, wrong gas or operated contrary to the Installation and Operating instructions.
- > This warranty is not valid on Conveyor Ovens *unless* a "start-up/check-out" has been performed by a Factory Authorized Technician.

### PARTS WARRANTY

Parts that are sold to repair out of warranty equipment are warranted for ninety (90) days. The part only is warranted. Labor to replace the part is chargeable to the customer.

### SERVICES NOT COVERED BY WARRANTY

- |  |   |
|--|---|
| 1. Travel time and mileage rendered beyond the 50 mile radius limit  | 10. Voltage conversions   |
| 2. Mileage and travel time on portable equipment ( <i>see below</i> )  | 11. Gas conversions   |
| 3. Labor to replace such items that can be replaced easily during a daily cleaning routine, ie; removable kettles on fryers, knobs, grease drawers on griddles, etc. | 12. Pilot light adjustment  |
| 4. Installation of equipment   | 13. Miscellaneous adjustments   |
| 5. Damages due to improper installation  | 14. Thermostat calibration and by-pass adjustment   |
| 6. Damages from abuse or misuse  | 15. Resetting of circuit breakers or safety controls or reset buttons                           |
| 7. Operated contrary to the Operating and Installation Instructions  | 16. Replacement of bulbs  |
| 8. Cleaning of equipment   | 17. Replacement of fuses  |
| 9. Seasoning of griddle plates   | 18. Repair of damage created during transit, delivery, & installation OR created by acts of God |

### PORTABLE EQUIPMENT

Star will not honor service bills that include travel time and mileage charges for servicing any products considered "Portable" including items listed below. These products should be taken to the Service Agency for repair:

- \* The Model 510FD Fryer.
- \* The Model J4R, 4 oz. Popcorn Machine.
- \* The Model 518CMA & 526CMA Cheese Melter.
- \* The Model 12MC & 15MC & 18MCP Hot Food Merchandisers.
- \* The Model 12NCPW & 15NCPW Nacho Chip/Popcorn Warmer.
- \* All Hot Dog Equipment **except Roller Grills & Drawer Bun Warmers.**
- \* All Nacho Cheese Warmers **except Model 11WLA Series Nacho Cheese Warmer.**
- \* All Condiment Dispensers **except the Model HPDE, & SPDE Series Dispenser.**
- \* All Specialty Food Warmers **except Model 130R, 11RW Series, and 11WSA Series.**
- \* All QCS/RCS Series Toasters **except Model QCS3 & RCS3 Series.**

#### ALL:

- \* Pop-Up Toasters
- \* Butter Dispensers
- \* Pretzel Merchandisers
- \* Pastry Display Cabinets
- \* Nacho Chip Merchandisers
- \* Accessories of any kind
- \* Sneeze Guards
- \* Pizza Ovens
- \* Heat Lamps
- \* Pumps

The foregoing warranty is in lieu of any and all other warranties expressed or implied and constitutes the entire warranty.

### FOR ASSISTANCE

Should you need any assistance regarding the Operation or Maintenance of any Star equipment; write, phone, fax or email our Service Department. In all correspondence mention the Model number and the Serial number of your unit, and the voltage or type of gas you are using.

MATERIAL			FINISH			MODEL NO. P012		PART NO.		
DR <i>WY.</i>	CK.	DATE 11-13-81	STAR MANUFACTURING CO.			TITLE <b>WIRING DIAGRAM</b>				
LIMITS UNLESS OTHERWISE NOTED FRACTIONS ± 1/64 DECIMALS ± .005			9325 OLIVE BOULEVARD ST. LOUIS MO. 63132			CHANGES	LTR	DATE	CHANGE	DR

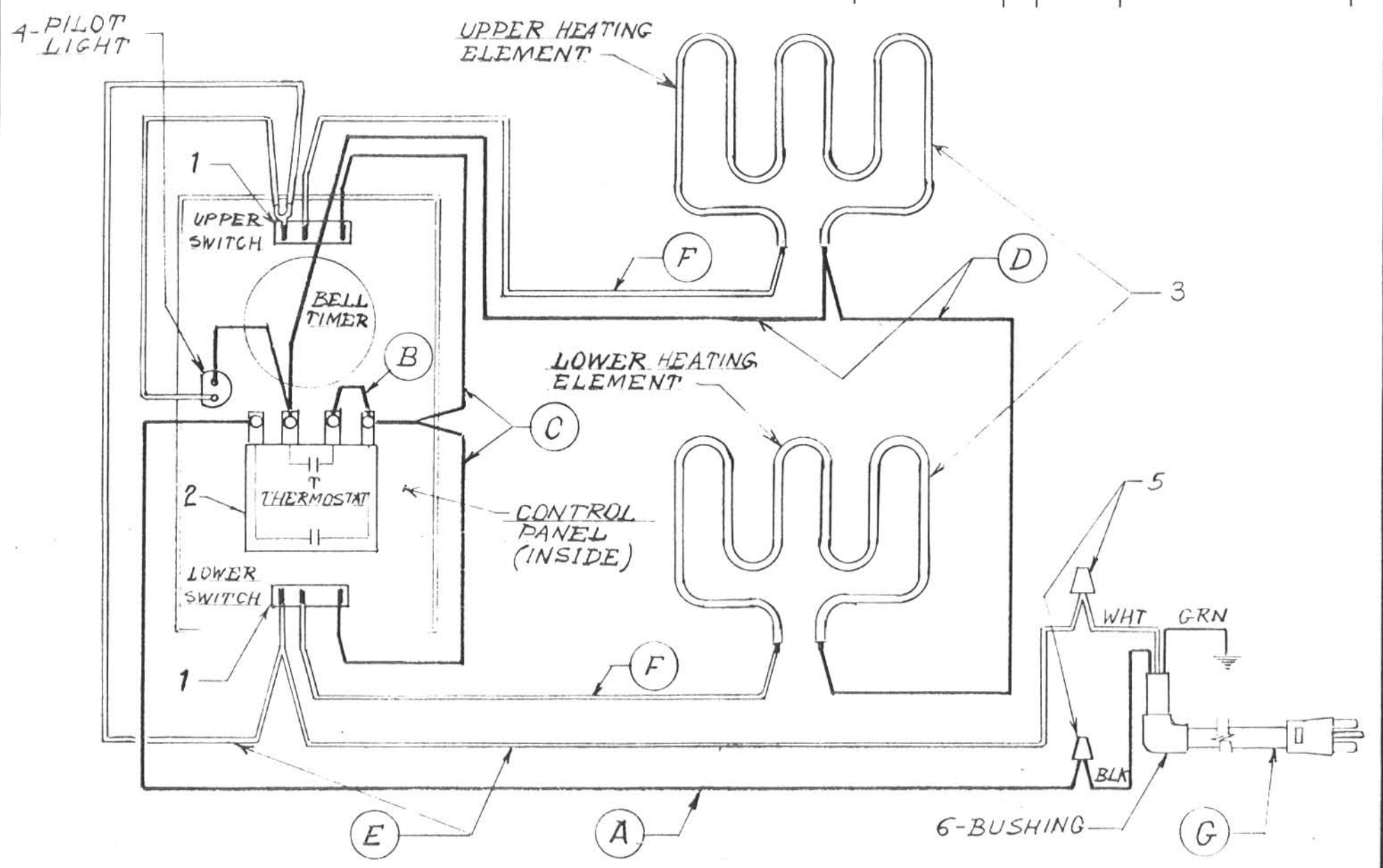

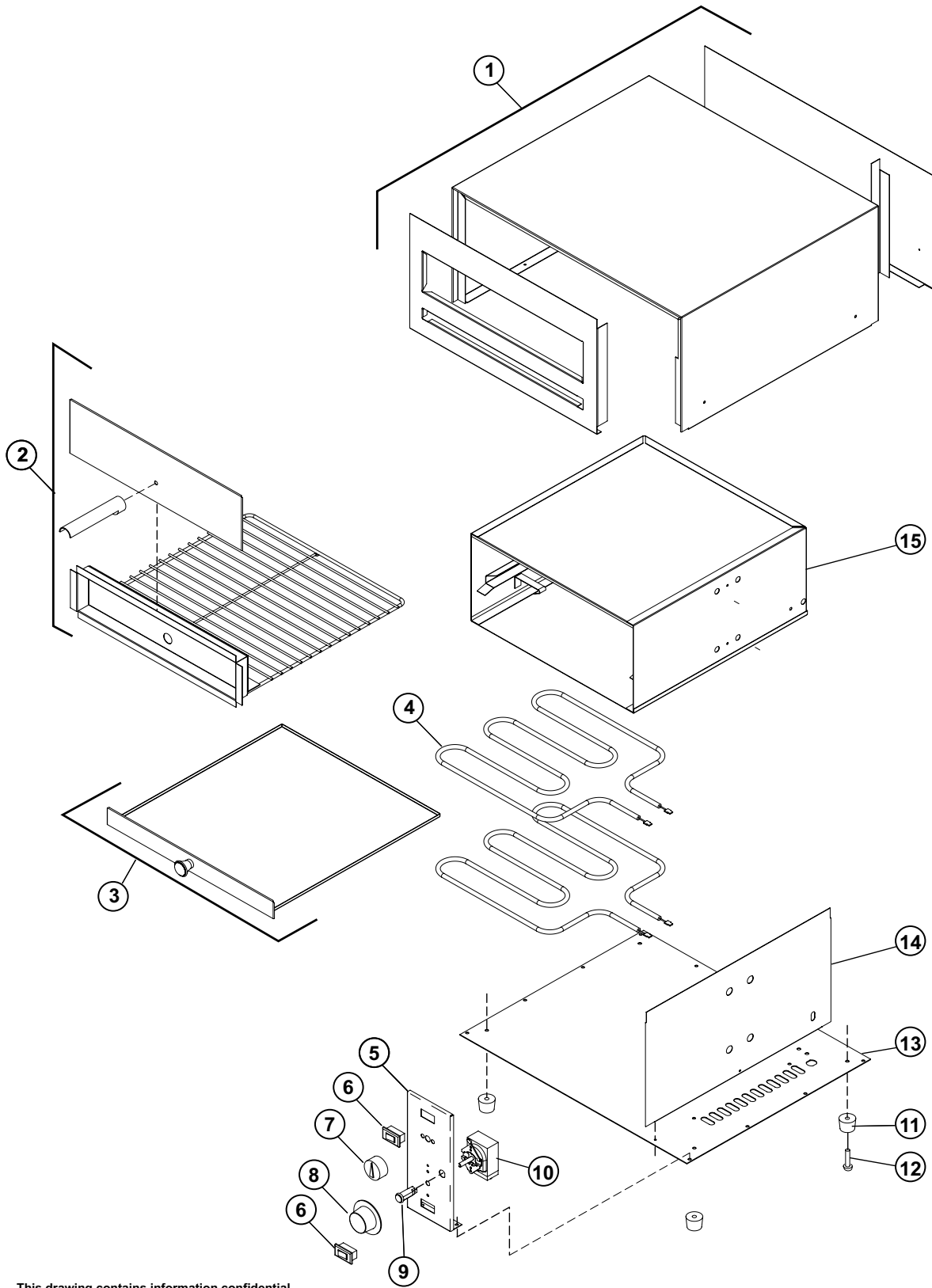

This drawing contains information confidential to Star Manufacturing International, Inc. No reproduction or disclosure of its contents is permitted.

SOME ITEMS ARE INCLUDED FOR ILLUSTRATIVE PURPOSES ONLY AND IN CERTAIN INSTANCES MAY NOT BE AVAILABLE

**MODEL: PO12**  
Electric Pizza Oven



SK2159 Rev. - 12/27/05

# PARTS LIST

February 1, 2006, Rev C

MODEL PO12 PIZZA OVEN

Key Number	Part Number	Number Per Unit	Description
1	B4-12101	1	PIZZA OVEN BODY ASSEMBLY
	B4-Y6047	1	FRONT PANEL, BODY ASSY
	B4-Y6046	1	BODY WRAP, BODY ASSY
	B4-Y6049	1	BACK PANEL, BODY ASSY
2	B4-12120	1	BAKING TRAY ASSEMBLY
	B4-12105	1	TRAY & DOOR ASSEMBLY
	B4-12121	1	WRAP DOOR ASSEMBLY
	B4-Y6057	1	SPACER
	B4-Y7352	1	HANDLE-FLIP UP TYPE
3	B4-12108	1	CRUMB TRAY ASSEMBLY
	B4-Y6068	1	CRUMB TRAY BODY
	B4-Y6069	1	CRUMB TRAY, FRONT PANEL
	2R-Z0872	1	KNOB, CRUMB TRAY
4	2N-Y6031	2	ELEMENT - 750W (120V) 19.2 Ω
	2N-Y6030	2	ELEMENT - 750W (208V) 19.2 Ω
	2N-Y6029	2	ELEMENT - 750W (240V) 19.2 Ω
5	B4-12103	1	CONTROL PANEL ASSEMBLY
6	2E-Y6044	2	SWITCH - ON/OFF
7	2R-Y6043	1	KNOB - TIMER
8	2R-Y6045	1	KNOB - THERMOSTAT
9	B4-12109	1	PILOT LIGHT ASSEMBLY
10	2T-Y6042	1	THERMOSTAT
11	2A-6904	4	FOOT
	2P-Y3404	4	RUBBER PLUG
12	2C-1557	4	SCREW, FOOT
13	B4-Y6041	1	BOTTOM PLATE
14	B4-Y6032	1	MIDDLE WALL
15	B4-12102	1	OVEN LINER ASSEMBLY
NI	2K-7889	1	BUSHING - CORD
NI	B4-12116	1	LEAD-IN-CORD (120V)
NI	B4-12118	1	LEAD-IN-CORD (208/240V)
NI	2P-7413	1	TIMER - BELL
NI	2R-7412	1	DIAL - TIMER
NI	2P-1170	3	JIFFY CLIP - THERMOSTAT BULB
NI	2C-9938	1	ADAPTER TERMINAL
NI	2R-Y1334	4	KNOB, SPACER
NI	1O-E1356	1	INSULATION 1" X 24" X 36" BOTTOM, TOP & SIDE
NI	1O-E1507	1	INSULATION 1/2 X 24" X 36" REAR
NI	2C-Y7396	1	SCREW (#4-40)
NI	2C-Y7397	1	NUT-LOCK (#4-40)

**IMPORTANT: WHEN ORDERING, SPECIFY VOLTAGE OR TYPE GAS DESIRED  
INCLUDE MODEL AND SERIAL NUMBER**

PAGE 1  
OF 1

Some items are included for illustrative purposes only and in certain instances may not be available.



**Star Manufacturing International, Inc.**