

**PIZZAS OF EIGHT PIZZA SYSTEMS
OPERATOR'S MANUAL
MODEL PC18**

PARTS LIST CONT.

<u>PART #</u>	<u>QTY.</u>	<u>DESCRIPTION</u>
2A-200672	3	Shaft Collar
GF-100922	1	Drive Shaft PC18
GF-100923	1	Idler Shaft PC18
GB-112262	4	Shaft Bushings
2P-200643	1	25B11 x 5/16 Sprocket
2P-200654	1	25B24 x 3/8 Sprocket
SP-115360	3	Knob w/Cap & Skirt
2U-200590	1	Drive Motor 220V 50Hz Right to Left Belt Travel
2U-200504	1	Drive Motor 208-240V 60Hz Left to Right Belt Travel
2U-200509	1	Drive Motor 208-240V 60Hz Right to Left Belt Travel
GD-118060	1	Speed Control
2U-200561	1	Fan Motor 208-240V 60Hz
2R-200562	1	Fan Grill
2E-200566	1	Reset Switch
GF-160009	1	Conveyor Belt PC18
GF-100709	1	Belt Support System PC18
GG-101419	1	LEFT Side Tray PC18
GG-100419	1	RIGHT Side Tray PC18
2E-200574	1	Fan Switch
GG-114250	9	Heater Tube, Metal, PC18, 208V
GF-197885	9	Heater Tube, Quartz, 690W@208V
GG-114255	9	Heater Tube, Metal, PC18, 220V
2N-209207	9	Heater Tube, Metal, PC18, 240V
2J-200567	2	Heat Controls Potentiometer, 10K
2J-200568	2	Heat Probe
2J-200569	2	Stratford Control Assembly
2J-200541	2	Phase Control Assembly
GD-150023	1	Drive Chain
2E-200552	1	On/Off Rocker Switch
GG-416166	2	Heat Shutters
2E-200554	4	Terminal Block

2M-200844, Bottom Heat Label 2M-200843, Top Heat Label

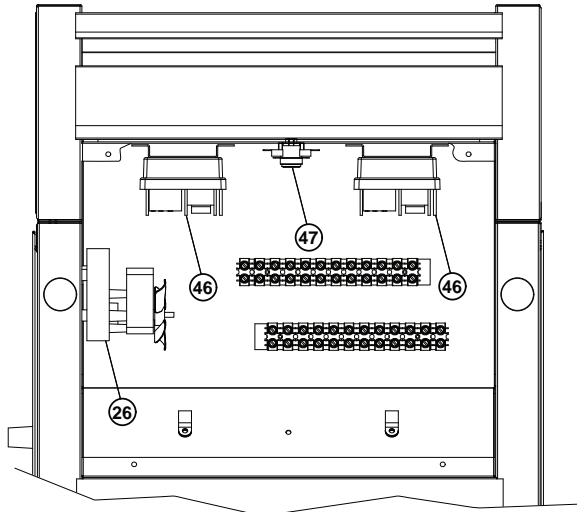

314 Stratford Control
Left to Right Conveyor

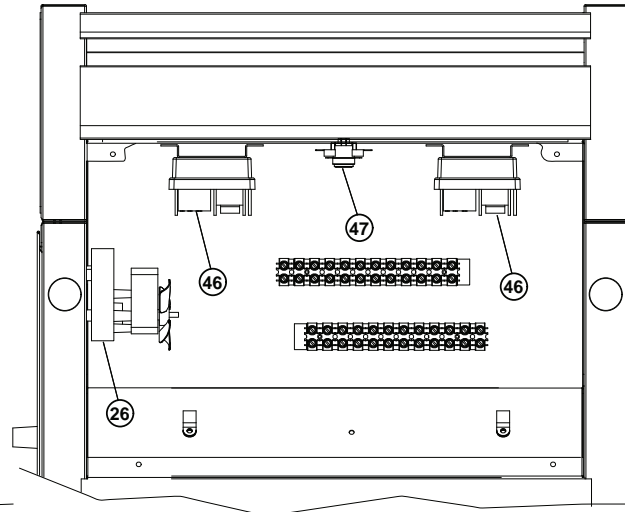

318 Stratford Control
Left to Right Conveyor

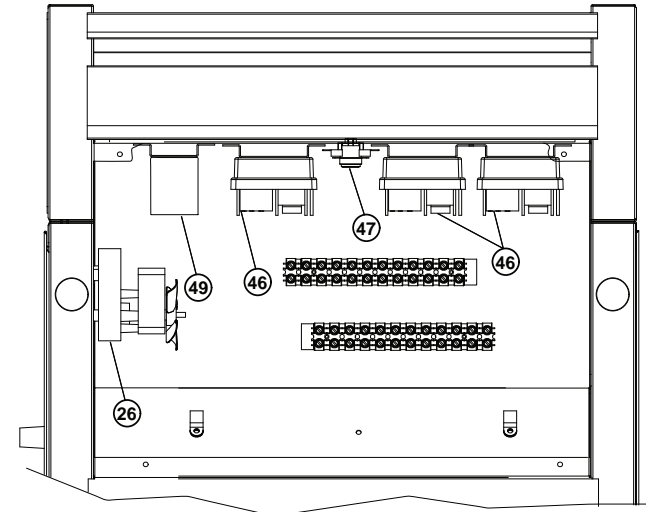

318 Stratford Control 3 Phase
Left to Right Conveyor

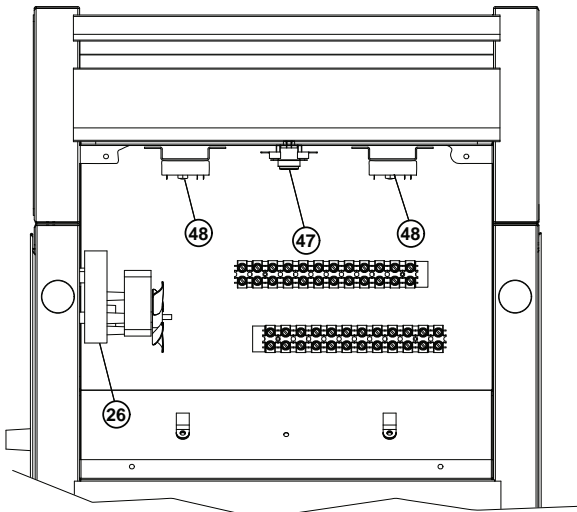

314 Phase Control
Left to Right Conveyor

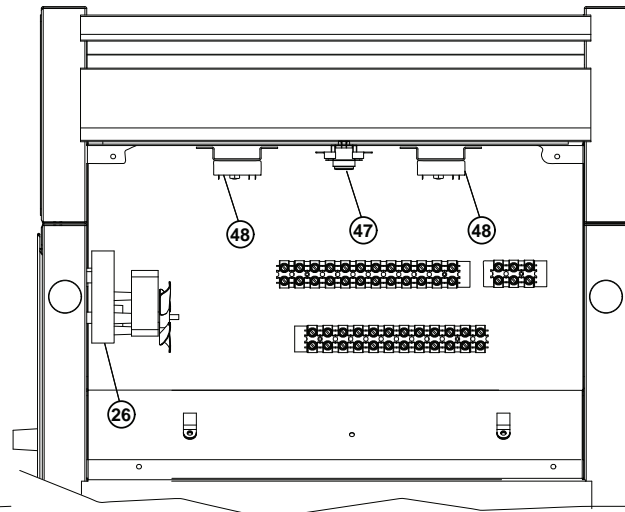

318 Phase Control
Left to Right Conveyor

MODEL: PROVEYOR CONTROL BOX CONFIGURATION



SK2146 Rev. - 9/12/05

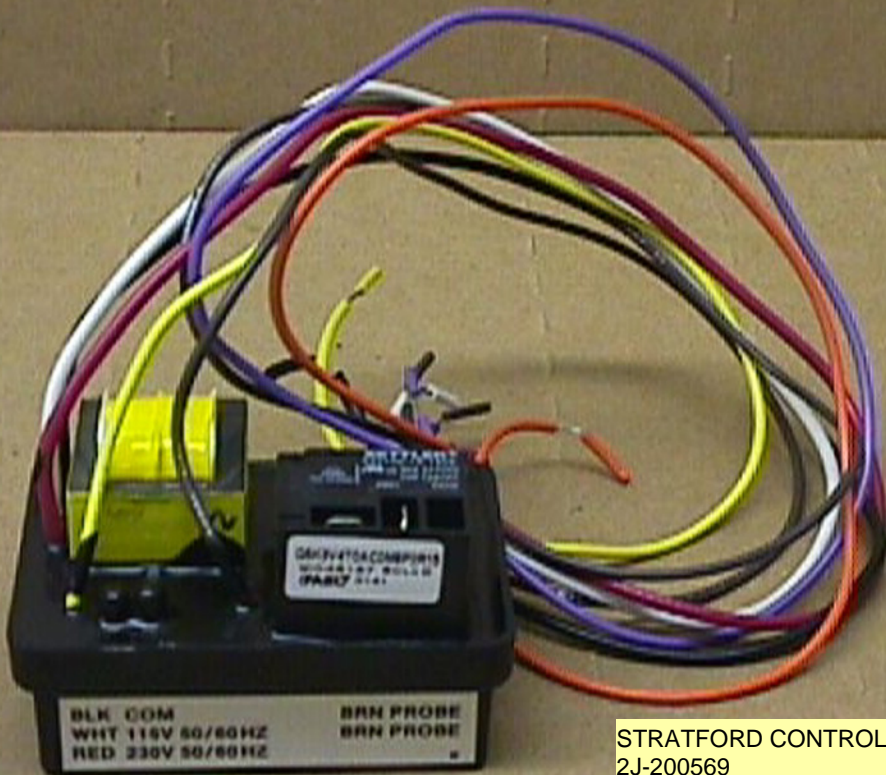

STRATFORD CONTROL
2J-200569



PHASE CONTROL
2J-200540



PHASE CONTROL
2J-200541