

# REPLACEMENT PARTS PRICE LIST

Effective:01/03/94

MODELS: NMS1, NMS2, NMS3-L; NMS1 BI, NMS2 BI, NMS3 BI-L (120V)  
NMS1, NMS2, NMS3-H; NMS1 BI, NMS2 BI, NMS3 BI-H (208/230V)

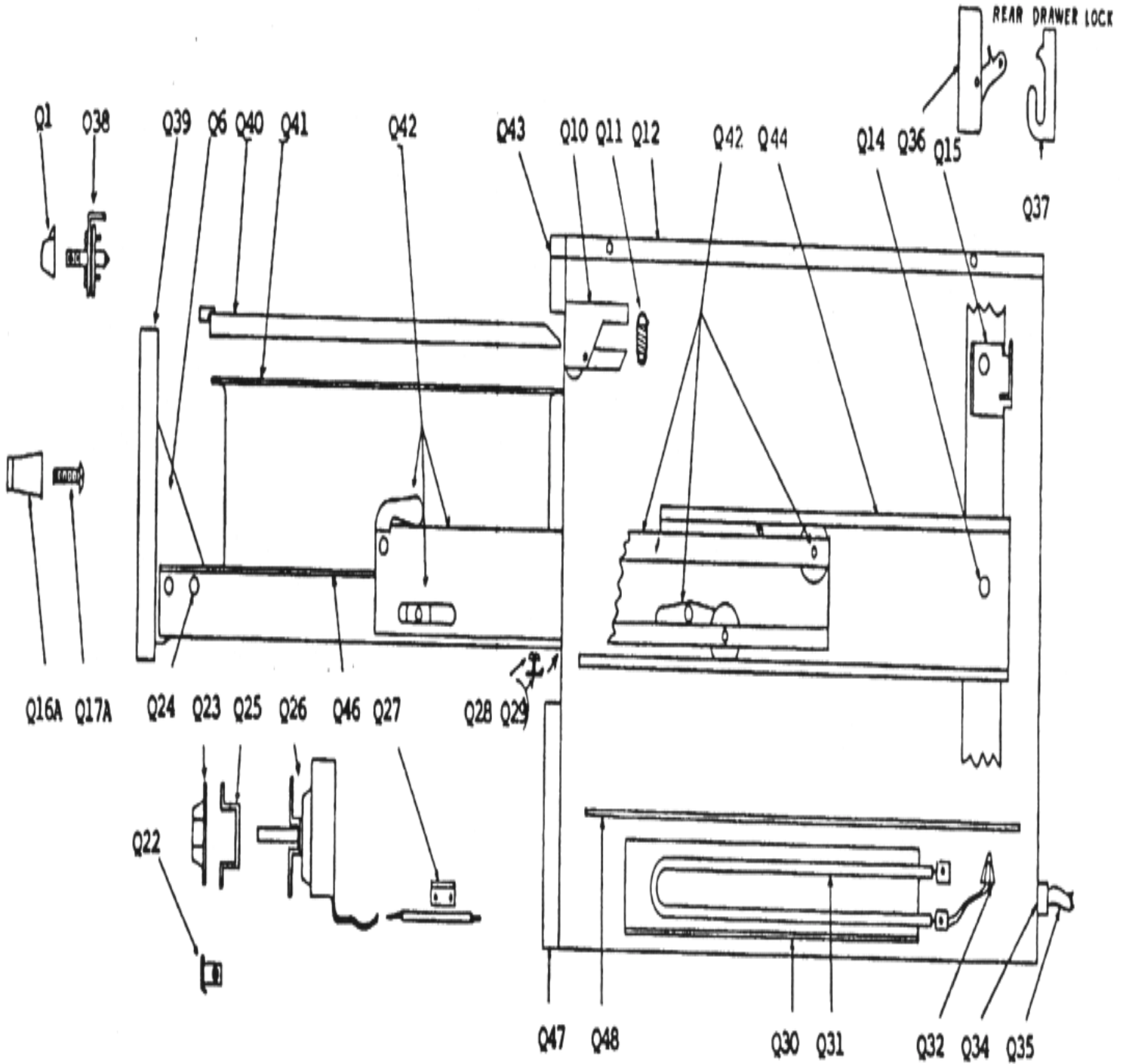

9E MODEL NMS Series Drawer Food Warmer

Key Number	Part Number	Number Per Unit	Description	
Q1	2R-09-FW-0006	1/2/3	MOIST CRISP CONTROL KNOB	NMS1/NMS2/NMS3
Q6	E9-04-FW-0111	1/2/3	DRAWER SUPPORT ( <b>LEFT</b> )	NMS1/NMS2/NMS3
	E9-04-FW-0060	1/2/3	DRAWER SUPPORT ( <b>RIGHT</b> )	NMS1/NMS2/NMS3
Q10,Q11	E9-30-FW-0043	1/2/3	LID LIFT ASSEMBLY	NMS1/NMS2/NMS3
Q12	E9-04-FW-0213	1	TOP, STAINLESS STEEL	
Q14			SCREW ( <i>OBTAIN LOCALLY</i> )	
Q15	E9-04-FW-0136	1/2/3	LID REST GUIDE ( <b>LEFT</b> )	NMS1/NMS2/NMS3
	E9-04-FW-0137	1/2/3	LID REST GUIDE ( <b>RIGHT</b> )	NMS1/NMS2/NMS3
Q16a	2R-Y7557	1/2/3	HANDLE - DOOR	NMS1/NMS2/NMS3
Q16b	2A-09-07-0222	2/4/6	HANDLE INSERT ( <i>not shown</i> )	NMS1/NMS2/NMS3
Q17a	2C-08-07-0048	2/4/6	HANDLE SCREW (10-32 x 1.75)	NMS1/NMS2/NMS3
Q22	Z1-30-07-0236	1	PILOT LIGHT ( <b>120V</b> )	
	E9-30-FW-0143	1	PILOT LIGHT ( <b>208/240V</b> )	
Q23	2R-09-07-0006	1	THERMOSTAT KNOB	
Q24			HEX HEAD SCREW ( <i>OBTAIN LOCALLY</i> )	
Q25	E9-04-FW-0243	1	THERMOSTAT BRACKET	
Q26	2T-05-FW-0003	1	THERMOSTAT, CAPILLARY TUBE TYPE	
Q27	E9-04-FW-0131	1	THERMOSTAT BULB HOLDER	
Q28			SCREW ( <i>OBTAIN LOCALLY</i> )	
Q30	E9-04-FW-0350	4	ELEMENT CLIP	
Q31	2N-05-FW-0002	1	ELEMENT, 600 WATT ( <b>120/208/240V</b> )	
Q32	2C-05-07-0036	2	PORCELAIN WIRE CONNECTOR (OLD STYLE)	
	2E-05-07-0057	1	TERMINAL BLOCK ( <i>NEW STYLE</i> ) ( <i>not shown</i> )	
Q34	2K-05-07-0017	1	STRAIN RELIEF, CORDSET	
Q35	2E-05-07-0051	1	LEAD-IN CORD ( <b>120V</b> )	
	2E-05-07-0049	1	LEAD-IN CORD ( <b>208/240V</b> )	
Q36	E9-30-FW-0044	1/2/3	REAR DRAWER LOCK	NMS1/NMS2/NMS3
Q37	E9-70-FW-0093	1/2/3	REAR DRAWER LOCK CATCH	NMS1/NMS2/NMS3
Q38	E9-30-FW-0045	1/2/3	MOIST CRISP CONTROL COMPLETE	NMS1/NMS2/NMS3
Q38a	2M-12-FW-0011	1/2/3	LABEL-M/C CONTROL ( <i>not shown</i> )	NMS1/NMS2/NMS3
Q39	E9-50-FW-0090	1/2/3	DRAWER FRONT <i>less</i> HANDLE	NMS1/NMS2/NMS3
Q40	E9-30-FW-0112	1/2/3	PAN LID ASSEMBLY	NMS1/NMS2/NMS3
Q41	2D-09-FW-0076	1/2/3	PAN, STAINLESS STEEL (16-9/16 x 11-11/16 x 6)	NMS1/NMS2/NMS3
Q42L	2D-30-FW-0037	1/2/3	DRAWER SLIDE-INNER TRACK ( <b>LEFT</b> )	NMS1/NMS2/NMS3
Q42R	2D-09-FW-0038	1/2/3	DRAWER SLIDE-INNER TRACK ( <b>RIGHT</b> )	NMS1/NMS2/NMS3
Q43	E9-04-FW-0049	1	FRONT	
Q44L	E9-30-FW-0114	1/2/3	DRAWER SLIDE-OUTER TRACK ( <b>LEFT</b> )	NMS1/NMS2/NMS3
Q44R	E9-30-FW-0115	1/2/3	DRAWER SLIDE-OUTER TRACK ( <b>RIGHT</b> )	NMS1/NMS2/NMS3
Q46	E9-30-FW-0005	1/2/3	DRAWER FRAME <i>less</i> FRONT	NMS1/NMS2/NMS3
Q47	2M-Z1607	1	FACEPLATE	
Q48	E9-04-FW-0314	1	ELEMENT COVER	
	2T-05-FW-0004	1	THERMOMETER FLANGE FRONT ( <i>OLD STYLE</i> ) ( <i>not shown</i> )	
	2T-05-FW-0010	1	THERMOMETER 2" DIAL ( <i>NEW STYLE</i> ) ( <i>not shown</i> )	
	E9-04-FW-0132	1	THERMOMETER BULB HOLDER	
	2P-09-FW-0025	2	RIGID WHEEL/CASTER ( <i>not shown</i> )	
	2P-09-FW-0026	2	SWIVEL WHEEL/CASTER ( <i>not shown</i> )	
	2A-09-FW-0023	4	LEG 6" ( <i>not shown</i> )	
	2A-09-FW-0024	4	LEG 12" ( <i>not shown</i> )	

IMPORTANT: WHEN ORDERING, SPECIFY VOLTAGE OR TYPE GAS DESIRED  
INCLUDE MODEL AND SERIAL NUMBER

PAGE 1  
OF 1

Some items are included for illustrative purposes only and in certain instances may not be available.

