

Ultra Max[®]

CONTACT TOASTER

MODEL
HCT13M, HCT13S
HCTE13M, HCTE13S
**Installation and
Operation
Instructions**

2M-Z19028 Rev. F 11/2018

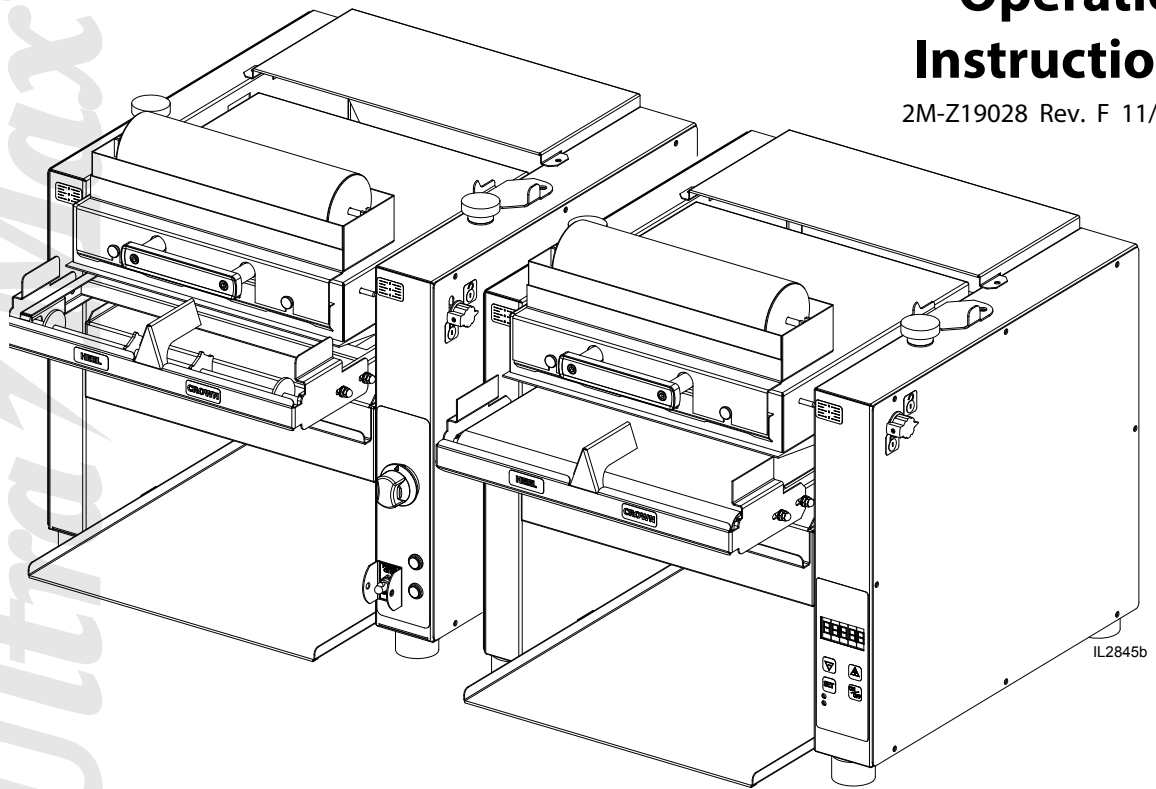

HCT13 & HCTE13
(Shown with optional butter wheel)



SAFETY SYMBOL



These symbols are intended to alert the user to the presence of important operating and maintenance instructions in the manual accompanying the appliance.

RETAIN THIS MANUAL FOR FUTURE REFERENCE NOTICE

Using any part other than genuine Star factory supplied parts relieves the manufacturer of all liability.

Star reserves the right to change specifications and product design without notice. Such revisions do not entitle the buyer to corresponding changes, improvements, additions or replacements for previously purchased equipment.

Due to periodic changes in designs, methods, procedures, policies and regulations, the specifications contained in this sheet are subject to change without notice. While Star International Holdings Inc., Company exercises good faith efforts to provide information that is accurate, we are not responsible for errors or omissions in information provided or conclusions reached as a result of using the specifications. By using the information provided, the user assumes all risks in connection with such use.

MAINTENANCE AND REPAIRS

Contact your local authorized service agent for service or required maintenance.

Please record the model number, serial number, voltage and purchase date in the area below and have it ready when you call to ensure a faster service.

Model No. _____
Serial No. _____
Voltage _____
Purchase Date _____

Authorized Service Agent Listing

Reference the listing provided with the unit

or

for an updated listing go to:

Website: www.star-mfg.com
E-mail customerservice@star-mfg.com

Service Help Desk

Business Hours: 8:00 am to 4:30 p.m. Central Standard Time

Telephone: (800)-264-7827

Fax: (314)-781-2714

E-mail customerservice@star-mfg.com

Website: www.star-mfg.com

Mailing Address: Star Manufacturing International Inc., Company
265 Hobson St.
Smithville, Tennessee 37166,
U.S.A

TABLE OF CONTENTS

Specifications	1
Features & Benefits	2
General Information	3
Uncrating & Inspecting	3
Electrical Connection	3
Assembly & Inspection	4
Toaster Settings	4
Daily Operation.	5 & 6
Cleaning	7
Troubleshooting	8
Maintenance	9-10
Warranty	11
Wiring Diagram.	12-13
Exploded View	14-17

SPECIFICATIONS

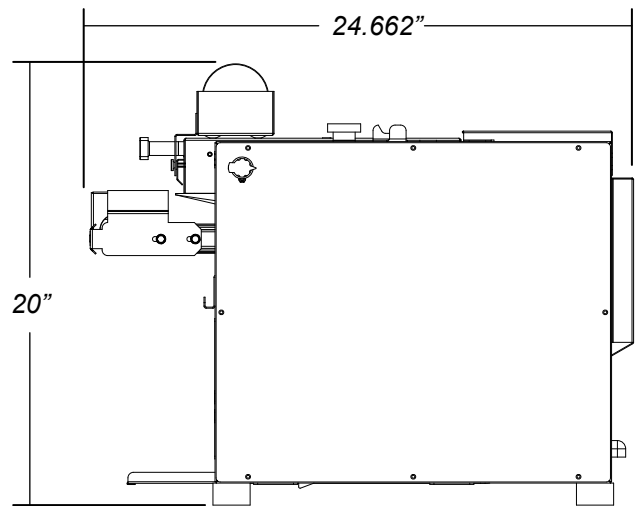
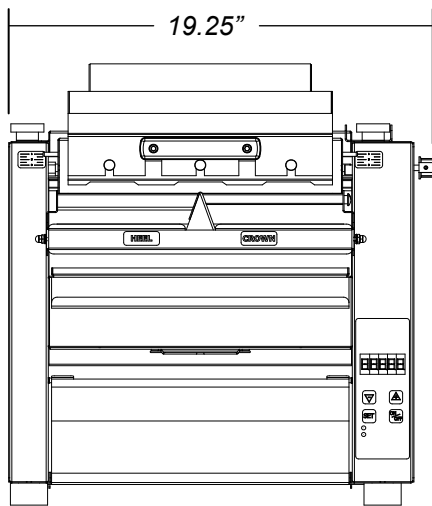

IL2844

Electrical Specifications						
Model	Voltage	Hz	Ph	Amps	Watts	Powercord
HCTE13M	208V	60	1	13.5	2800	6-20P
	230V	50		12	2750	CEE7/VII
	240V	60		12.5	3000	6-20P
HCTE13S	208V	60		12.25	2550	6-20P
	230V	50		10.5	2450	CEE7/VII
	240V	60		11	2650	6-20P

HCT13M	208V	60	1	13.5	2800	6-20P
	230V	50		12	2750	CEE7/VII
	240V	60		12.5	3000	6-20P
HCT13S	208V	60		12.25	2550	6-20P
	230V	50		10.5	2450	CEE7/VII
	240V	60		11	2650	6-20P

FEATURES & BENEFITS

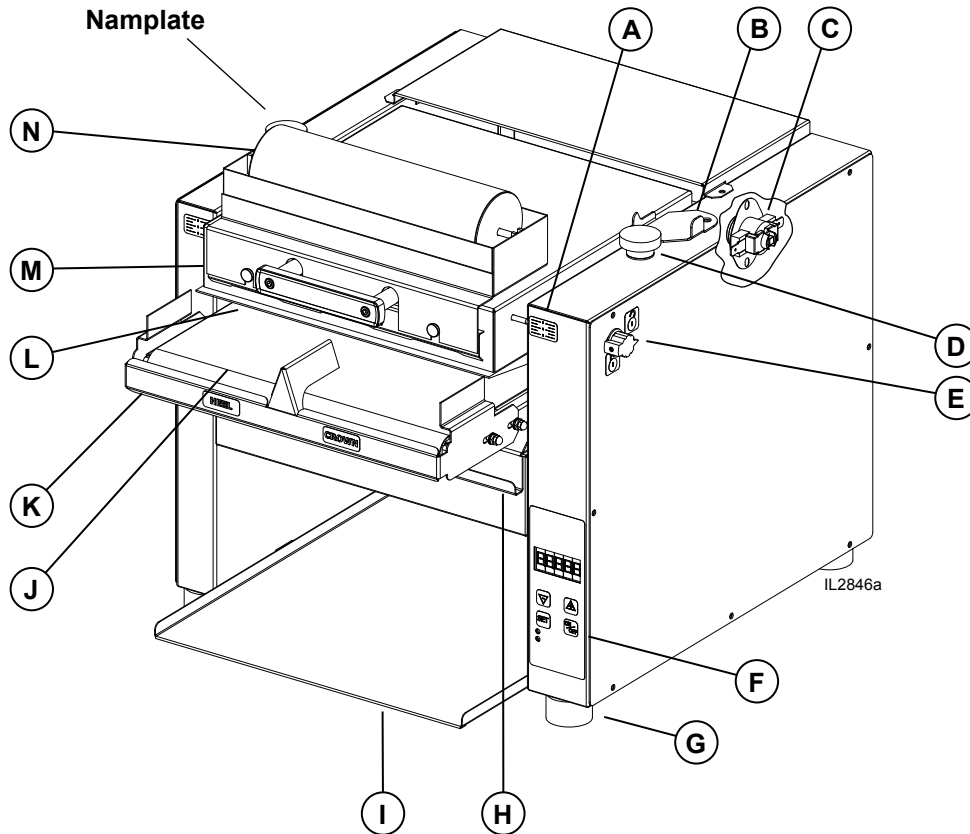

A	Platen Height Indicator	Indicates the height of the upper platen
B	Platen Support Bracket	Keeps the upper platen in the up position, useful while cleaning
C	High Limit	Interrupts the heater tube connections if the air temperature in the control box exceeds 190°F (88°C). This limit switch can be reset manually by pushing the button in the center of the switch.
D	Platen Height Knob	Controls the height of the upper platen
E	Locking Platen Latch	Keeps the upper platen in the down position.
F	Control Board	Controls the conveyor speeds, turns unit on & off, & temperature settings.
G	Foot	Silicone foot keeps unit firmly in place.
H	Crumb Tray	Slide out crumb tray used to catch particles from falling
I	Toaster Chute	Removable Chute returns product for easy access.
J	Conveyor	Takes the heel and crown separately through their toasting process
K	Burn Guard	Protects users from touching the conveyor belt
L	Durable Non-Stick Coated Sheet	Non-Stick surface between the upper platen and the product, allowing the product to slide easily through the toasting process.
M	Upper Platen Assy	Heating surface designed to toast the product as it slides across the surface
N	Optional Butter Wheel	Saves time for preparing buns for toasting

GENERAL INFORMATION



This equipment is designed and sold for commercial use only by personnel trained and experienced in its operation and is not sold for consumer use in and around the home nor for use directly by the general public in food service locations.

Before using your new equipment, read and understand all the instructions & labels associated with the unit prior to putting it into operation. Make sure all people associated with its use understand the units operation & safety before they use the unit.

INSPECTION

UN-CRATING AND INSPECTING

Unpack the unit and components from the shipping container. Remove all visible packing material and those from inside the cooking chamber. If damage is discovered, file a claim immediately with the carrier that handled the shipment. Do not operate the unit if it was damaged during shipping. All shipping containers should be checked for freight damage both visible and concealed. This unit has been tested and carefully packaged to insure delivery of your unit in perfect condition. If equipment is received in damaged condition, either apparent or concealed, a claim must be made with the delivering carrier.

Concealed damage or loss - if damage or loss is not apparent until after equipment is unpacked, a request for inspection of concealed damage must be made with carrier within 15 days. Be certain to retain all contents plus external and internal packaging materials for inspection. The carrier will make an inspection and will supply necessary claim forms.

ELECTRICAL CONNECTION

Disconnect the unit from the power source before installing or removing any parts.

Be absolutely sure that the ground connection for the receptacle is properly wired.

Do not connect equipment to power without proper ground connections. Improper grounding may result in personal injury or death.



CAUTION

Allow enough space around the toaster for adequate ventilation. Do not operate the unit without the crumb tray properly positioned. Overheating and poor toasting may occur. Read all labels on the unit and follow their instructions.



WARNING

Before making any electrical connection to this unit, check that the power supply is adequate for the voltage, amperage and requirements stated on the rating plate. A wiring diagram is included.



WARNING

DO NOT CUT OR REMOVE THIS PLUG OR THE GROUNDING PRONG FROM THE PLUG. FAILURE TO COMPLY MAY RESULT IN DEATH OR SERIOUS INJURY.



WARNING

CONNECT/PLUG UNIT INTO DEDICATED A. C. LINE ONLY SPECIFIED ON THE DATA PLATE OF THE UNIT.



CAUTION

SOME SURFACES ARE EXTREMELY HOT DURING OPERATION AND CARE SHOULD BE TAKEN WHILE USING THIS UNIT.

ASSEMBLY AND INSTALLATION

The unit was shipped fully assembled and ready to plug into a standard outlet specified for its voltage and amp draw. If improper electrical supply is determined, contact a qualified electrician prior to using the unit. Removal and replacement of the power cord and plug voids the warranty. For assistance, contact your local authorized service agent for service or required maintenance.

1. Place the unit in its operating location.
2. Wipe down the exterior with a damp cloth.
3. Place the Toaster Chute & Crumb Tray into position.
4. Unlock the Platen Latch and raise the platen, move the Platen Support Bracket to hold the platen in the up position.
5. Loosen the Sheet Retainer and install the non-stick sheet into position, and secure.
6. Lower the Platen and latch in place.

CAUTION

Failure to use non-stick sheets can lead to damaging the unit and a loss of warranty. The durable non-stick coated sheets are not a warranty item.

TOASTER SETTINGS

Before using the unit for the first time, test the pass time of the conveyor belt.

The pass time through the toaster should be between 16 to 20 seconds for standard setting.

1. Turn unit ON and wait for it to complete the PRE-HEAT process.
2. Set the Platen height by adjusting the two (2) Platen Height Knobs on top of the unit.
3. Make sure the platen lock is on.
4. Place a bun on the conveyor belt, cut side up, "HEEL" on one side and "CROWN" on the other.

IF TO DARK: Decrease TEMP.

IF TO LIGHT: Increase TEMP. or lower platen

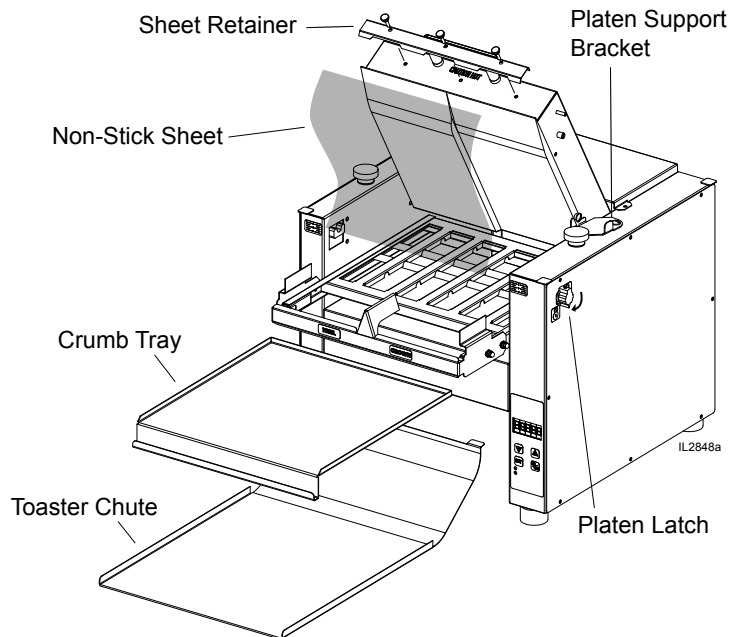

DAILY OPERATION ELECTONIC CONTROL

CHANGING TEMPERATURE

1. Push and hold the "SET TEMP" button for three seconds.
2. The display will flash the current top temperature setting.
3. Using the ↑ and ↓ adjust the top heat to desired temperature (increments of 10°)
4. Press the "SET TEMP" button again to change the bottom heat setting.
5. Using the ↑ and ↓ adjust the bottom heating setting (0 – 10).
6. Press the "SET TEMP" button again to save the settings and exit program mode.

CHANGING CONVEYOR SPEED

1. Push and hold the ↑ and ↓ for three seconds
2. Using the ↑ and ↓ adjust the motor speed to the desired setting (1 through 99)
3. Press the "SET TEMP" button to exit the program

CHECK TEMPERATURE SETTING

1. Press the "SET TEMP" button to check the platen temperature.

CLEAN MODE

1. Press the "CLEAN" button to enter the clean mode
 - a. Elements will be turned OFF and the belt will continue to run
 - b. The screen will flash CLEAN and WAIT.
 - c. When the platen has lowered to a safe temperature the screen will flash CLEAN and READY.
2. Press the "ON/OFF" button to exit the clean mode.

CHANGING BUN THICKNESS SETTING

1. Set the "Height Adjustment Knobs" to their desired settings.
2. Turn unit ON, allow to warm-up before proceeding.
3. Place buns on the conveyor, cut side up.
4. Toasted buns will drop down the toaster chute.
5. Turn the "Height Adjustment Knobs" to lower the platen for darker buns, raise for lighter buns.

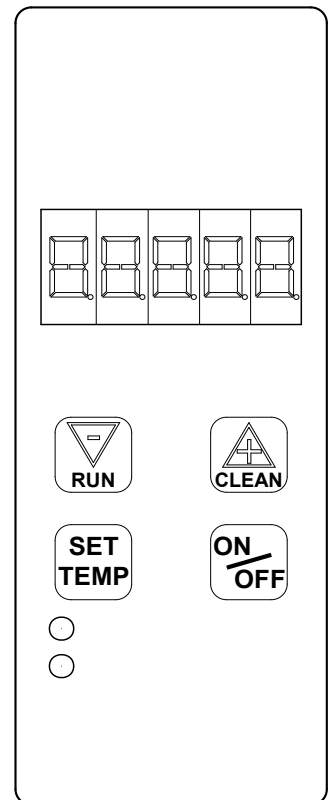

IL2856



CAUTION

CERTAIN SURFACES ARE EXTREMELY HOT DURING OPERATION AND CARE SHOULD BE TAKEN WHILE USING THIS UNIT.

DAILY OPERATION MANUAL CONTROL

OPERATING

1. Turn the Power Switch to the "ON" position
2. The conveyor belt will begin to move.
3. Using Temperature Knob, move it from the "OFF" position to your desired temperature.
4. The Element Power Light will turn "ON" when the unit is calling for heat. When your desired temperature is reached, the light will turn "OFF". Wait for the Element Power Light to cycle twice before using.
5. When finished using, turn the Temperature Knob to the "OFF" position, but leavet the Power Switch in the "ON" position to allow the cooling fan to run.
6. Once cooled, move the switch to the "OFF" position.

CHANGING CONVEYOR SPEED

Changing conveyor speed is only capable on the electronically controlled units.



CAUTION THIS UNIT.

CERTAIN SURFACES ARE EXTREMELY HOT DURING OPERATION AND CARE SHOULD BE TAKEN WHILE USING THIS UNIT.

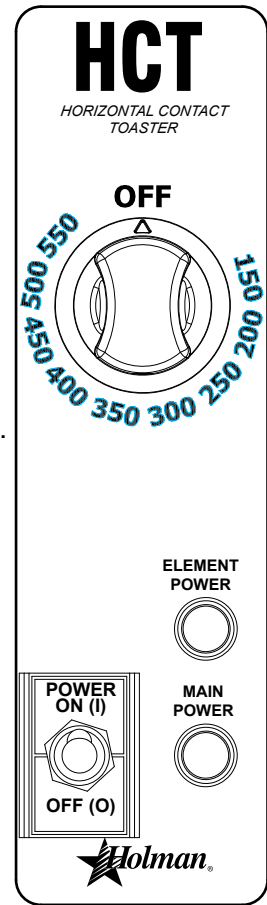

IL2912

CHANGING BUN THICKNESS SETTING

1. Set the "Height Adjustment Knobs" to their desired settings.
2. Turn unit ON, allow to warm-up before proceeding.
3. Place buns on the conveyor, cut side up.
4. Toasted buns will drop down the toaster chute.
5. Turn the "Height Adjustment Knobs" to lower the platen for darker buns, raise for lighter buns.

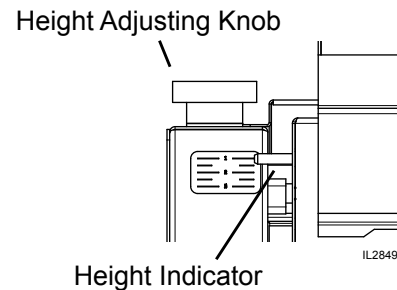

IL2849

2M-Z19028; Holman Contact Toaster

CLEANING

Preventive maintenance for your Ultra-Max Contact Toaster consists of the following recommended cleaning procedures. To keep your toaster in top operating condition, these steps should be performed daily or weekly as indicated.

Daily Cleaning

1. **MANUAL:** Turn the temp knob to the "OFF" position, and the power switch in the "ON" position.

ELECTRONIC: Press and hold the CLEAN button to enter cleaning mode.

- a. The screen will flash "CLEAN" "WAIT" while the unit cools down to a safe temperature.
- b. Unlock platen using knob on side, raise the platen and prop open to speed up cool down.
Always remove Butter before raising platen if used.
- c. The screen will flash "CLEAN" "READY" when the unit has cooled to a safe temperature.

IMPORTANT: Allow the unit to cool before attempting to clean it.

2. Wipe down moving belt with mild detergent and damp cloth.
(an abrasive pad can be used on metal belt).
3. Wipe down exterior of toaster with mild detergent and damp cloth.
4. Remove non-stick sheet and clean with mild detergent and damp cloth. (If excess buildup is unable to be removed and causing buns to stick to the sheet, a new sheet may need to be installed.)
5. Remove crumb tray and toast slide and wash in a sink with mild detergent.
6. Dry and return crumb tray, toast slide, and non-stick sheet back into position.
7. Turn the power switch to the "OFF" position, until you need



WARNING

**DO NOT IMMERSE OR LET THE UNIT STAND IN WATER.
DO NOT HOSE DOWN THE UNIT OR THE TABLE/COUNTER IF THE
UNIT IS ON THE TABLE/COUNTER.
KEEP AWAY FROM RUNNING WATER.**



CAUTION

**DO NOT use caustic
cleaners on any surface
of the unit, conveyor belt
or Durable Non-Stick
Coated Sheets**

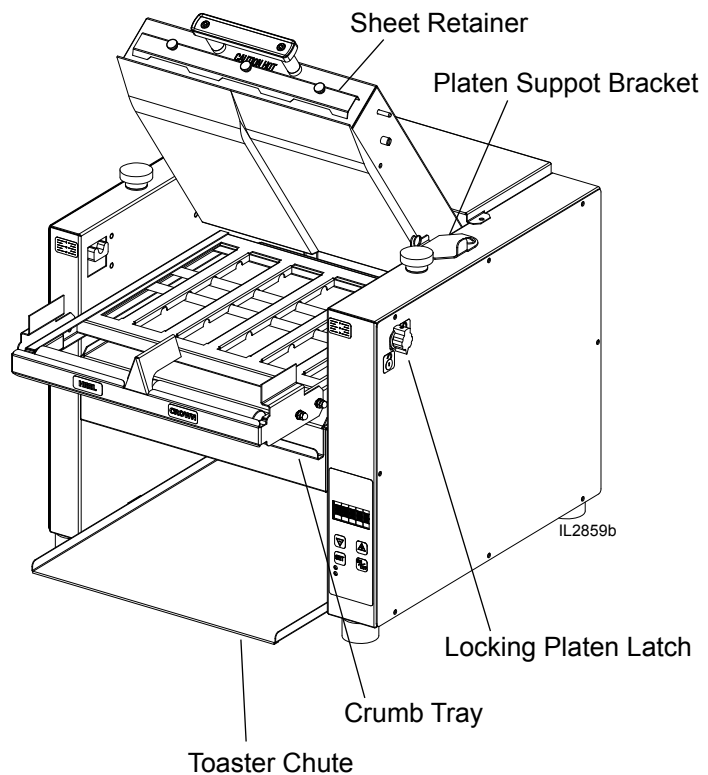

TROUBLESHOOTING GUIDE

A. Unit Will Not Heat, Conveyor Belt Will Not Move.

- 1) Be sure the main circuit breaker is switched to the ON
- 2) Check to see if the toaster is plugged in and all controls are turned to the ON position.

B. Unit Has Heat Only On One Side, Conveyor Belt Turns Freely.

- 1) Contact your local service agent,, as heating element may need replacing.

C. Conveyor Will Not Turn, Unit Heats Properly.

To check for mechanical binding:

- 1) **DISCONNECT UNIT FROM POWER SOURCE.**
- 3) Remove 4 screws on the back of the toaster and remove back panel.
- 4) Remove the right side panel.
- 5) Loosen the four screws that hold the drive motor in place.
- 6) Slide the motor up allowing the drive chain to be removed from the sprockets.
- 7) Move the conveyor belt by hand to check for mechanical binding. If conveyor moves freely, contact your local service agent,, as the drive motor and/or speed control may need replacing.
- 8) Re-install the rear and side panels.

D. Heat Limit Switch (Reset)

Your Ultra-Max contact toaster is equipped with an automatically activated heat limit switch that interrupts the heater tube connections if the ambient temperature in the control box exceeds 190°F (88°C). This switch can be reset manually by pushing the red button located behind the right side panel as shown in the Components Illustration on Page 2.

- 1) **DISCONNECT UNIT FROM POWER SOURCE.**
- 2) Check to see if air intake area in the bottom center of the control box cover is free of dust, grease or other obstructions.
- 3) Check if crumb tray is in place. .
- 4) If no obstructions to the airflow can be found contact your local service agent, for assistance.

E. Conveyor Turns At One Speed Regardless Of Speed Control Setting

(HCTE models only).

- 1) Contact your local service agent,, as speed control should be replaced.

F. Product Sticking To Conveyor Or Slide

Your Ultra-Max Contact Toaster is designed to toast product that is current room temperature.

DO NOT attempt to put frozen, refrigerated material in the toaster.

Doing so may cause it to come out doughy or very moist, as well as possibly sticking to parts of the unit. Follow the cleaning procedures.

MAINTENANCE PROCEDURES

A. Replacing the Bottom Element

- 1) **DISCONNECT UNIT FROM POWER SOURCE.**
- 2) Remove the side panels and bottom panel.
- 3) Remove element wire from terminal block connection, keeping top and bottom wires separate.
- 4) Lift element retainers by loosening retaining screws and removing the retainer plate up.
- 5) Gently, pull defective element out of unit.
- 6) Gently, put new element into unit.
- 7) Slide the retainer back into place. Tighten the screw to secure the retainer in place over the ends of the elements.

B. Replacing the Fan Motor

- 1) **DISCONNECT UNIT FROM POWER SOURCE.**
- 2) Remove the toaster slide.
- 3) Remove screws from the bottom panel.
- 4) Unplug power supply cord from fan motor.
- 5) Remove (4) screws, which hold fan motor and grill to bottom of unit and remove fan.
- 6) Put replacement motor and grill in place and secure to the bottom of unit with screws.
- 7) Reconnect power supply cord to fan motor.
- 8) Replace bottom panel. Fasten with screws removed in step 2.

C. Replacing the Belt Drive Motor

- 1) **DISCONNECT UNIT FROM POWER SOURCE.**
- 2) Remove the right side and bottom panels.
- 3) Remove sprocket from motor shaft, using an Allen wrench and loosening the set-screw.
- 4) Remove the wire from terminal block connecting the drive motor to internal wiring.
On units rated 208 or 240 volts, note which color leads are being used for these connections and which lead is capped with white tape. The new motor should use the same arrangement.
- 5) Remove screws holding motor in place and remove motor from unit.
- 6) Put new motor in place and attach loosely with mounting screws.
- 7) Replace sprocket on motor shaft.

NOTE The two sprockets should line up parallel with each other, so the chain does not twist any during operation. Also the hub gets installed closets to the motor.

- 8) Slide motor until the drive chain has about 1/4" slack when lightly pushed at the center of its top open run. *See chain tensioning illustration.*
- 9) Tighten screws to secure motor.
- 10) Rewire leads same as removed in step 4.
- 11) Replace previously removed panels.

D. Clean the Air Intake (Once A Week)

- 1) **DISCONNECT UNIT FROM POWER SOURCE.**
- 2) Place unit on its backside.
- 3) Use a vacuum cleaner and or a damp cloth to clean the air intake.

E. Lubricate the Chain & Sprockets (Every 6 Months)

- 1) **DISCONNECT UNIT FROM POWER SOURCE.**
- 2) Remove enclosure exposing chain drive.
- 3) While wearing rubber gloves and using an extreme pressure, synthetic chain lubricant with a temperature range up to 400°F (204°C) lubricate chain and sprockets. Apply liberally. This grease is available as part no. [1L-Z12397](#).
- 4) Replace enclosure, Reconnect power source and test unit.

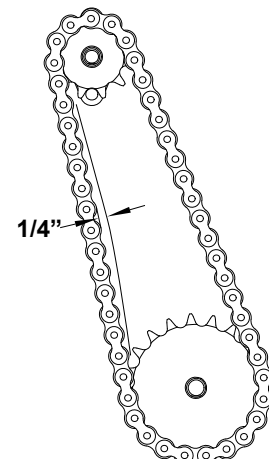

Chain Tension

MAINTENANCE continued

REMOVING & REPLACING SILICONE BELT

1. Disconnect unit from power allow to cool before beginning process.
2. Remove guard from in front of the belt.
3. Rotate belt by hand until belt seam is visible.
4. The Idler Shaft is spring loaded. Press on the front idler shaft to remove tension from the belt. (*Continuous pressure is required*).
5. Pull splicing rod from belt.
6. Carefully release pressure from idler shaft so the roller is not propelled from the unit by the springs.
7. Installation is similar to removal. Feed the belt around the drive shaft and idler shaft rollers making sure the tracking guide on the backside of the belt is seated in the roller grooves.
8. Press the front roller to create slack in the belt.
9. Feed the splicing rod through the two ends of the belt.
10. Remove pressure from roller and install belt guard.
11. Plug unit back into outlet and test for proper operation.

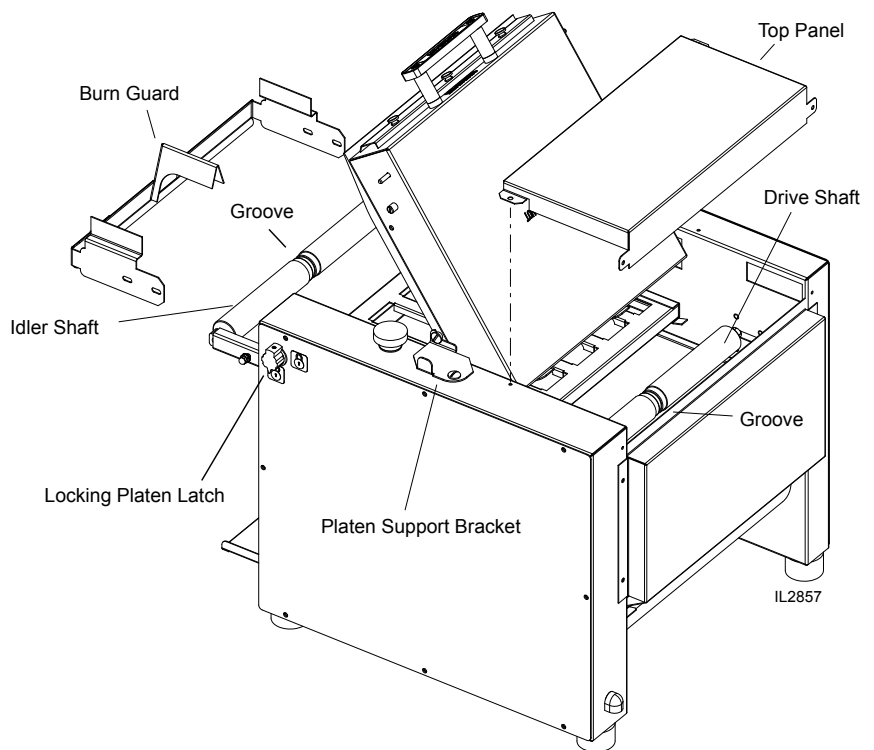

Above: Removing and Installing Silicone Belt



DISCONNECT THE POWER SUPPLY BEFORE SERVICING OR CLEANING THIS OVEN. SAFEGUARD THE POWER SO IT CANNOT BE ACCIDENTALLY RESTORED. FAILURE TO DO SO COULD RESULT IN DISMEMBERMENT, ELECTROCUTION, OR FATAL INJURY.

Visit our Website at: www.star-mfg.com

Email: customerservice@star-mfg.com

THOROUGHLY INSPECT YOUR UNIT ON ARRIVAL

This unit has been tested for proper operation before leaving our plant to insure delivery of your unit in perfect condition. However, there are instances in which the unit may be damaged in transit. In the event you discover any type of damage to your product upon receipt, you must immediately contact the transportation company who delivered the item to you and initiate your claim with same. If this procedure is not followed, it may affect the warranty status of the unit.

LIMITED EQUIPMENT WARRANTY

All workmanship and material in Star products have a one (1) year limited warranty on parts & labor in the United States and Canada. Such warranty is limited to the original purchaser only and shall be effective from the date the equipment is placed in service. Star's obligation under this warranty is limited to the repair of defects without charge, by the factory authorized service agency or one of its sub-agencies. Models that are considered portable (*see below*) should be taken to the closest Star service agency, transportation prepaid.

- > Star will not assume any responsibility for loss of revenue.
- > On all shipments outside the United States and Canada, see International Warranty.
- * The warranty period for the Ultra-Max, Hot Plates, Griddles, Charbroilers is (3) years parts & labor.
- * The warranty period for the Star-Max, Charbroilers, Griddles, Hot Plates, Fryers & Finishing Oven is (2) years parts & labor.
- * The warranty period for the JetStar six (6) ounce & Super JetStar eight (8) ounce series popcorn machines is two (2) years.
- * The warranty period for the Chrome-Max Griddles is five (5) years on the griddle surface. See detailed warranty provided with unit.
- * The warranty period for Dura-Tec coatings is one year under normal use and reasonable care. This warranty does not apply if damage occurs to Dura-Tec coatings from improper cleaning, maintenance, use of metallic utensils, or abrasive cleaners, abrasive pads, product identifiers and point-of-sale attachments, or any other non-food object that comes in continuous contact with the roller coating. This warranty does not apply to the "non-stick" properties of such materials.
- > This warranty does not apply to "Special Products" but to regular catalog items only. Star's warranty on "Special Products" is six (6) months on parts and ninety (90) days on labor.
- > This warranty does not apply to any item that is disassembled or tampered with for any purpose other than repair by a Star Authorized Service Center or the Service Center's sub-agency.
- > This warranty does not apply if damage occurs from improper installation, misuse, wrong voltage, wrong gas or operated contrary to the Installation and Operating instructions.
- > This warranty is not valid on Conveyor Ovens *unless* a "start-up/check-out" has been performed by a Factory Authorized Technician.

PARTS WARRANTY

Parts that are sold to repair out of warranty equipment are warranted for ninety (90) days. The part only is warranted, the labor to replace the part is **NOT** warranted.

SERVICES NOT COVERED BY WARRANTY

1. Travel time and mileage rendered beyond the 50 mile radius limit
2. Mileage and travel time on portable equipment (*see below*)
3. Labor to replace such items that can be replaced easily during a daily cleaning routine, ie; removable kettles on fryers, knobs, grease drawers on griddles, etc.
4. Installation of equipment
5. Damages due to improper installation
6. Damages from abuse or misuse
7. Operated contrary to the Operating and Installation Instructions
8. Cleaning of equipment
9. Seasoning of griddle plates
10. Voltage conversions
11. Gas conversions
12. Pilot light adjustment
13. Miscellaneous adjustments
14. Thermostat calibration and by-pass adjustment
15. Resetting of circuit breakers or safety controls or reset buttons
16. Replacement of bulbs
17. Replacement of fuses
18. Repair of damage created during transit, delivery, & installation OR created by acts of God

PORTABLE EQUIPMENT

Star will not honor service bills that include travel time and mileage charges for servicing any products considered "Portable" including items listed below. These products should be taken to the Service Agency for repair:

- * The Model 510FD, 510FF Fryer.
- * The Model 526TOA Toaster Oven.
- * The Model J4R, 4 oz. Popcorn Machine.
- * The Model 518CMA & 526CMA Cheese Melter.
- * The Model 12MC & 15MC & 18MCP Hot Food Merchandisers.
- * The Model 12NCPW & 15NCPW Nacho Chip/Popcorn Warmer.
- * All Hot Dog Equipment **except Roller Grills & Drawer Bun Warmers.**
- * All Nacho Cheese Warmers **except Model 11WLA Series Nacho Cheese Warmer.**
- * All Condiment Dispensers **except the Model HPD & SPD Series Dispenser.**
- * All Specialty Food Warmers **except Model 130R, 11RW Series, and 11WSA Series.**
- * All QCS/RCS Series Toasters **except Model QCS3 & RCS3 Series.**
- * All Fast Steamer Models **except Direct Connect Series.**

ALL:

- * Pop-Up Toasters
- * Butter Dispensers
- * Pretzel Merchandisers
(Model 16PD-A Only)
- * Pastry Display Cabinets
- * Nacho Chip Merchandisers
- * Accessories of any kind
- * Sneeze Guards
- * Pizza Ovens
(Model PO12 Only)
- * Heat Lamps
- * Pumps-Manual

The foregoing warranty is in lieu of any and all other warranties expressed or implied and constitutes the entire warranty.

FOR ASSISTANCE

Should you need any assistance regarding the Operation or Maintenance of any Star equipment; write, phone, fax or email our Service Department. In all correspondence mention the Model number and the Serial number of your unit, and the voltage or type of gas you are using.

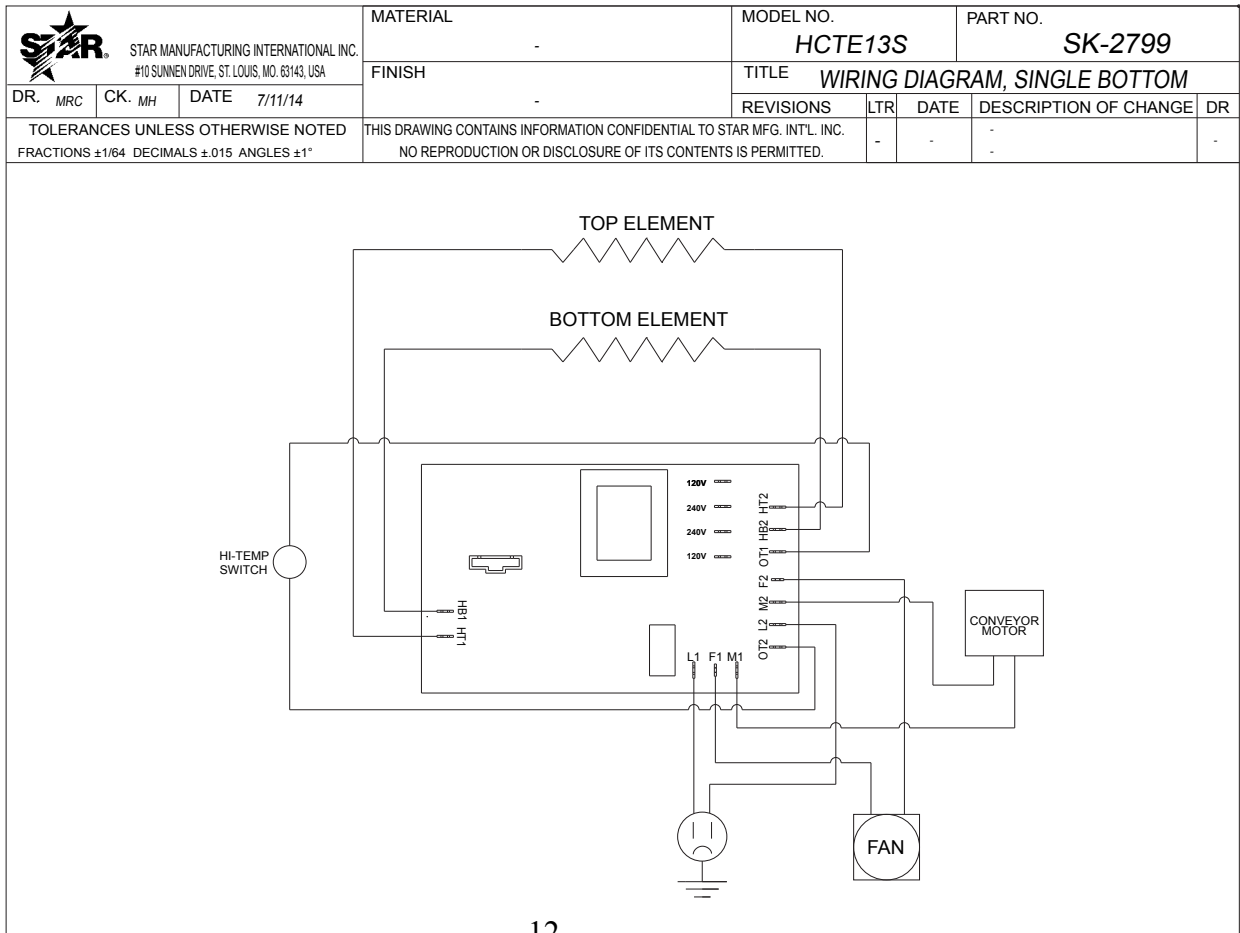
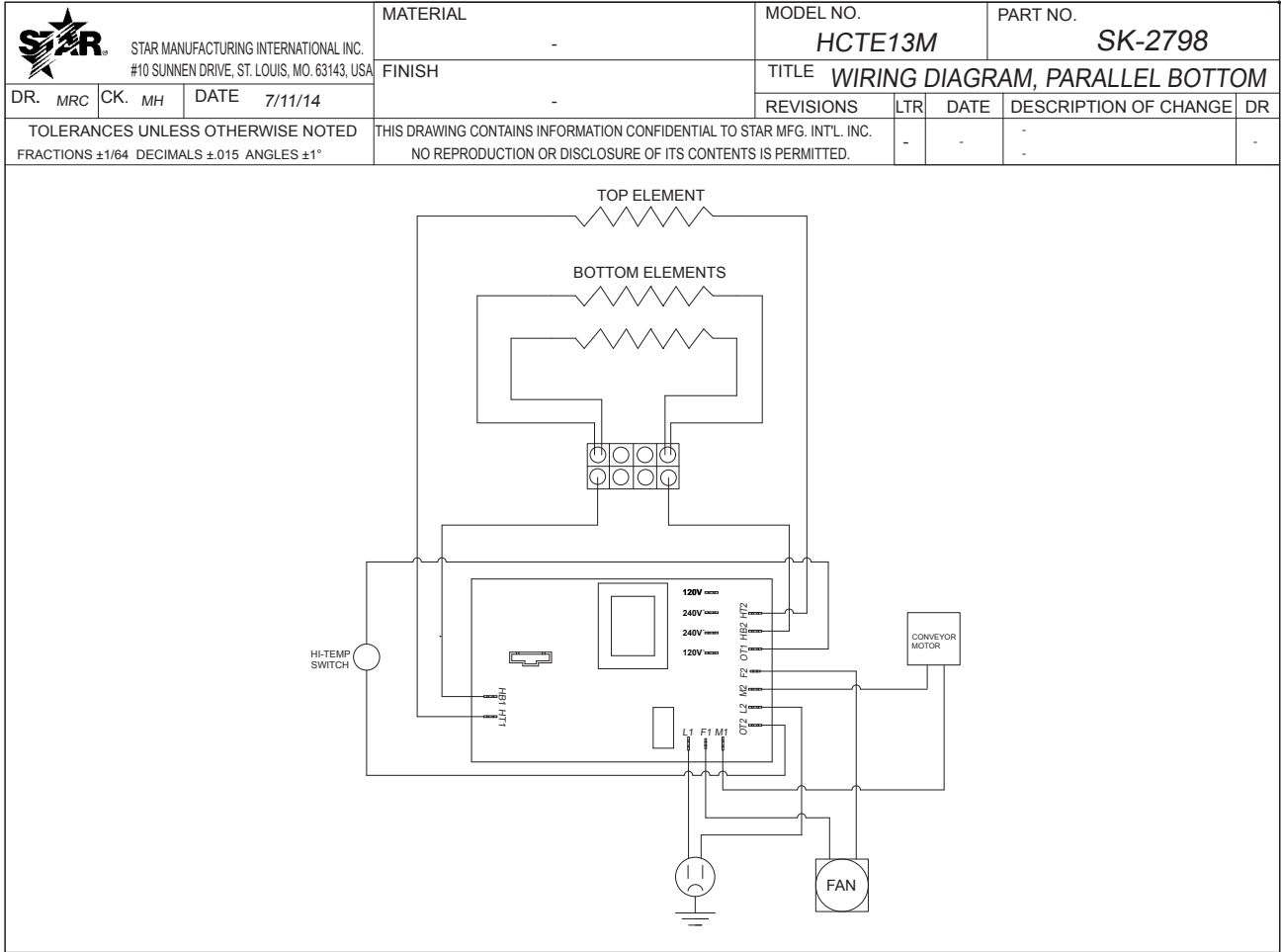

2M-Z19028; Holman Contact Toaster



STAR MANUFACTURING INTERNATIONAL INC.
#10 SUNNEN DRIVE, ST. LOUIS, MO. 63143, USA

MATERIAL	-
FINISH	-

MODEL NO.	HCT13M
TITLE	WIRING DIAGRAM, PARALLEL BOTTOM

PART NO.	SK-2823
----------	---------

DR.	MRC	CK. MH	DATE	10/23/14
TOLERANCES UNLESS OTHERWISE NOTED FRACTIONS ±1/64 DECIMALS ±.015 ANGLES ±1°				

THIS DRAWING CONTAINS INFORMATION CONFIDENTIAL TO STAR MFG. INT'L. INC. NO REPRODUCTION OR DISCLOSURE OF ITS CONTENTS IS PERMITTED.				
--	--	--	--	--

REVISIONS	LTR	DATE	DESCRIPTION OF CHANGE	DR
A		10/31/18	MOVED WIRE #6 FROM AUX	DLH

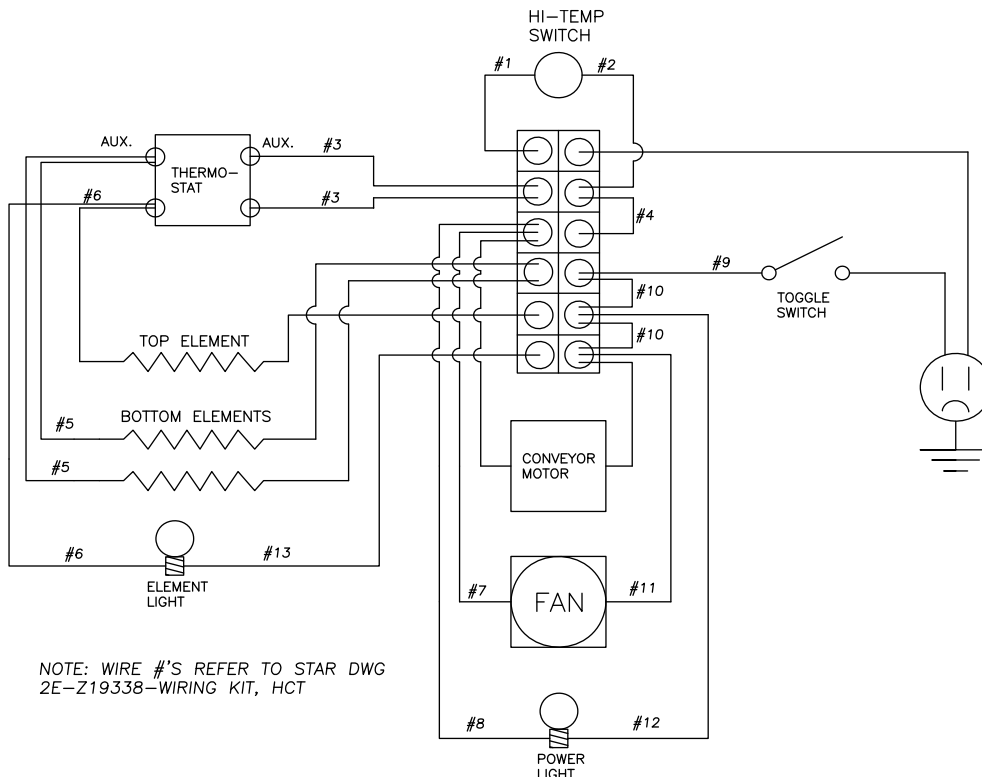

STAR MANUFACTURING INTERNATIONAL INC.
#10 SUNNEN DRIVE, ST. LOUIS, MO. 63143, USA

MATERIAL	-
FINISH	-

MODEL NO.	HCT13S
TITLE	WIRING DIAGRAM, SINGLE BOTTOM

PART NO.	SK-2824
----------	---------

DR.	MRC	CK. MH	DATE	10/23/14
TOLERANCES UNLESS OTHERWISE NOTED FRACTIONS ±1/64 DECIMALS ±.015 ANGLES ±1°				

THIS DRAWING CONTAINS INFORMATION CONFIDENTIAL TO STAR MFG. INT'L. INC. NO REPRODUCTION OR DISCLOSURE OF ITS CONTENTS IS PERMITTED.				
--	--	--	--	--

REVISIONS	LTR	DATE	DESCRIPTION OF CHANGE	DR
A		10/31/18	MOVED WIRE #6 FROM AUX	DLH

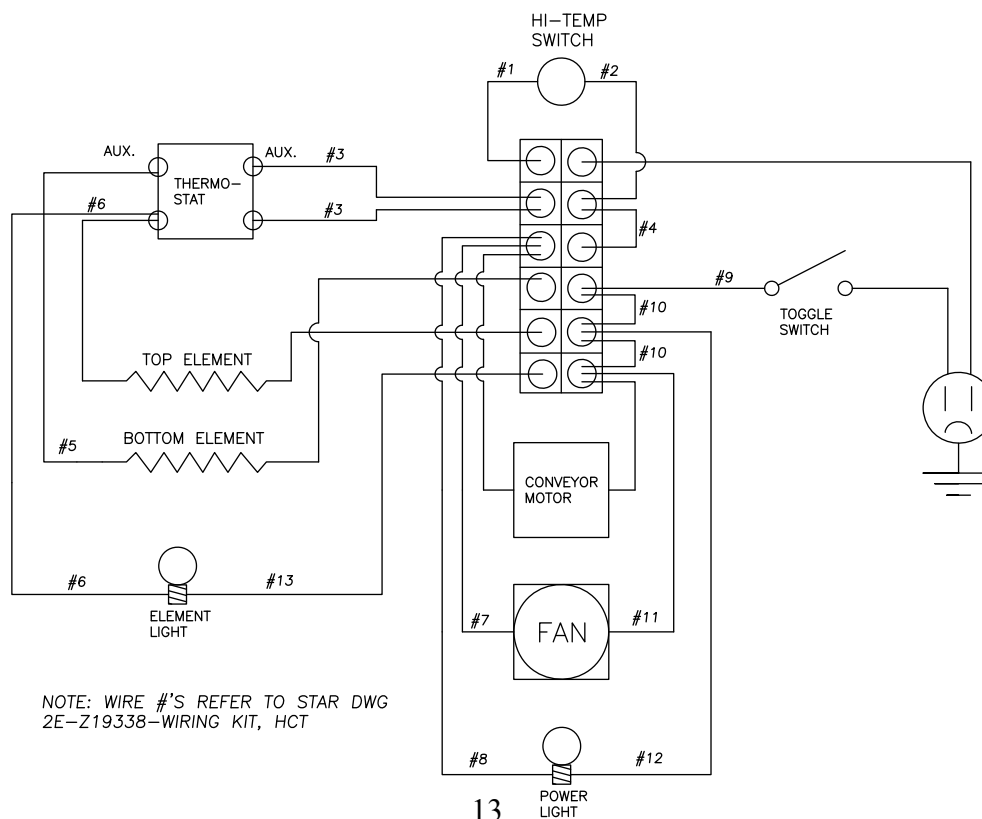

Optional Accessory

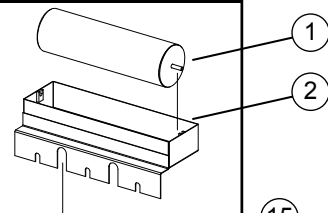

HCT13 Manual Control

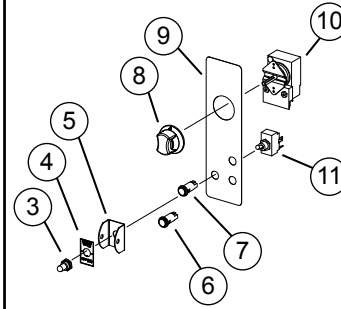

HCTE13 Electronic Control

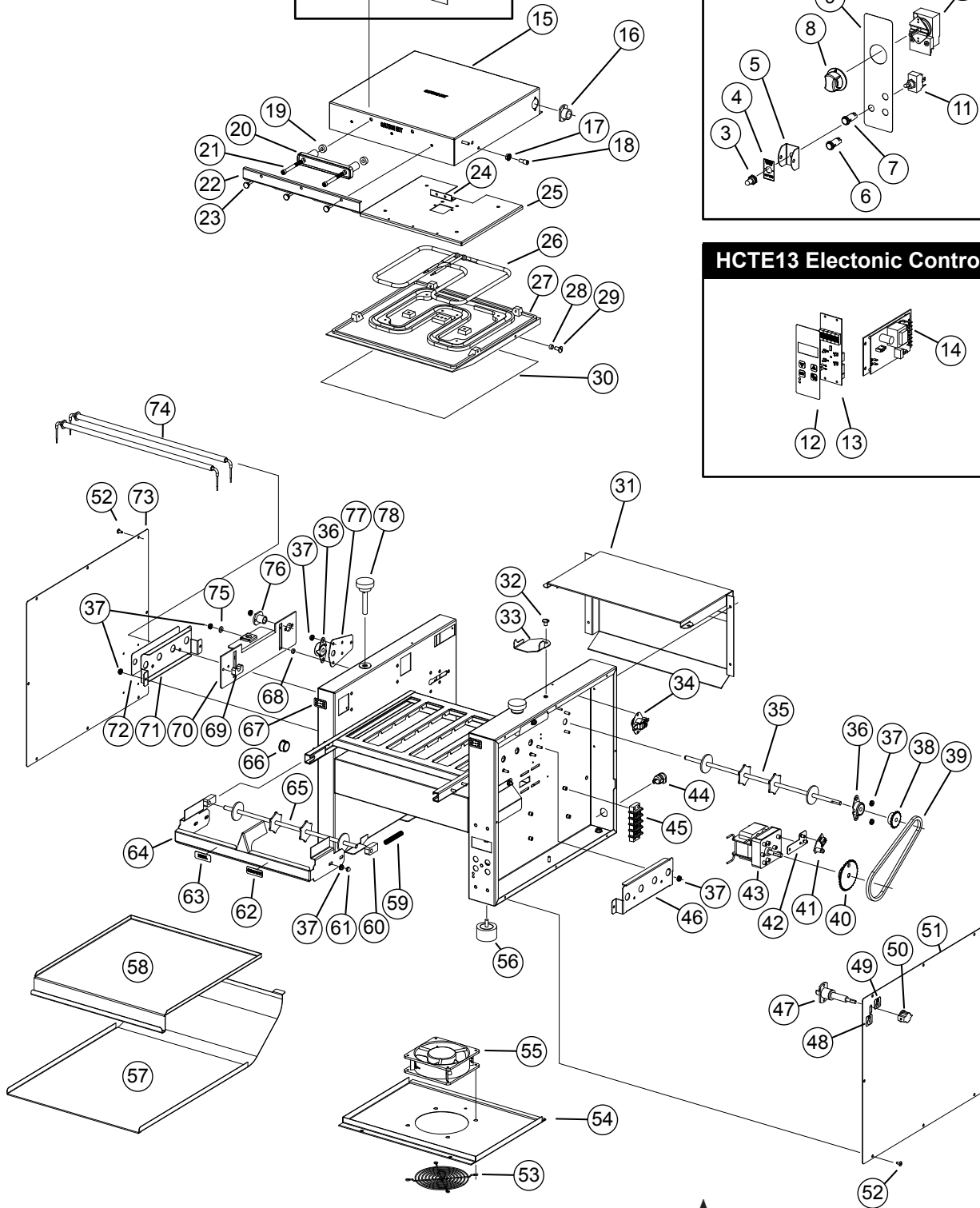
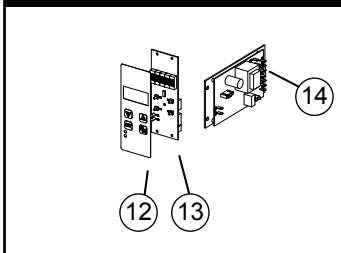

**Model: HCTE & HCT Contact Toasters
w/electronic & manual controls**



2M-Z19028; Holman Contact Toaster

PARTS LIST

October 13, 2015, Rev. E

Model: HCTE13 & HCT13 Contact Toaster				
Fig No	Part No	Quantity	Description	Application
1	HC-CT0018	Optional	Butter Wheel Weldment	
2	HC-CT0017	Optional	Butter Wheel Base Weldment	
3	2I-05-07-0013	1	BOOT SWITCH	HCT13
4	2M-Z18461	1	LABEL, POWER, ON & OFF	HCT13
5	Z1-70-07-0343	1	SWITCH GUARD	HCT13
6	2J-31157	1	LIGHT SIGNAL RED, MAIN POWER	HCT13
7	2J-31157	1	LIGHT SIGNAL RED, ELEMENT PWR	HCT13
8	2R-Z18145	1	KNOB, SG 1.75 X .25 SHAFT	HCT13
9	2M-Z19266	1	LABEL, HCT	HCT13
10	2T-Z18396	1	THERMOSTAT, 150-550°F	HCT13
11	2E-30330	1	SWITCH ON OFF TOGGLE 20A	HCT13
12	2M-Z18207	1	LABEL, HCTE	HCTE13
13	2J-Z17717	1	ELECTRONIC CONTROL SPEC	HCTE13
14	2U-200592	1	QCSE PWRBRD, W/RIBBONCABLE	HCTE13
15	HC-CT0005	1	PLATEN COVER ASY	
16	2K-Z17714	2	BUSHING, OUTER	
17	2C-6517	6	NUT 1/4-20 HEX STL NP	
18	2A-Z17716	2	SUPPORT, 1/4-20 X 11/32	
19	2A-Z17727	2	SPACER, 5/8"OD X 0.266"ID	
20	2R-Y2830	1	HANDLE HARRY DAVIES 4560	
21	2C-Z18503	2	SCREW, SOCKET CAP 1/4-20	
22	HC-Z17713	1	RETAINER, PTFE SHEET	
23	2A-Z17712	3	THUMBSCREW 8-32 X .375	
24	HC-Z17724	1	THERMOPROBE BRKT	HCTE13
25	HC-Z17711	1	ELEMENT COVER	
26	2N-Z17710	1	ELEMENT, METAL 2300W 240V	240V, 230V
	2N-Z17749		ELEMENT, METAL 2300W 208V	208V
27	2F-Z17708	1	13" TOP CASTING	
28	2A-Z18504	1	SPACER, 3/8IN X 1/4IN	
29	2C-Y7595	1	BOLT 1/4-20X1/2 THS STL	
30	2H-Z18588	1	PTFE SHEET, 0.003 TK	
31	HC-CT0006	1	BACK PANEL ASY	
32	2C-Z10075	1	SCREW-1/4-20X3/8 SS THS	
33	HC-Z17737	1	PLATEN SUPPORT BRKT	
34	2E-200566	1	SWTCH,RSET,0796-190F TRPS	
35	2A-CT0015	1	BELT DRIVE SHAFT ASSEMBLY	HCTE13M
	2A-CT0015SB			HCTE13S
36	HA-112261	2	BEARING ASSY PTFE/BRONZE	
37	2C-Z6929	34	NUT, 10-24 KEPS SS	
38	2P-200646	1	SPROCKET, 25B20 X 5/16	

PARTS LIST

October 13, 2015, Rev. E

Model: HCTE13 & HCT13 Contact Toaster				
Fig No	Part No	Quantity	Description	Application
39	2P-150013	1	DRIVE CHAIN #25 ROLLER	
40	2P-200648	1	SPROCKET, 25B32 X 5/16	
41	2E-Z17514	1	SENSOR, SPEED	HCTE13
42	HC-CT0008	1	SPEED CONTROL BRKT ASY	HCTE13
43	2U-Z9657	1	MOTOR,11RPM-CW,NEW STYLE	
44	2K-Y3240	1	BUSHING HEYCO SR 17-2	
45	2E-Z10406	1	TERMINAL BLOCK 4 POS	HCTE13M
	2E-Z14254		TERMINAL BLOCK 6-POLE	HCT13
46	HC-CT0013	1	RIGHT ADJUSTMENT BRKT ASY	
47	HC-CT0014	1	PLATEN LATCH ASY	
48	2M-Z18513	1	LABEL, UNLOCK SYMBOL	
49	2M-Z18512	1	LABEL, LOCK SYMBOL	
50	2R-Z17729	1	KNOB, 1-1/4 X 5/8 X 1/2	
51	HC-Z17742	1	PANEL, RIGHT COVER	
52	2C-6349	24	SCREW #8X3/8 B THP STL NP	
53	2R-200562	1	FAN GUARD	
54	HC-Z17740	1	MOTOR HOUSING COVER	
55	2U-200561	1	MOTOR, FAN 240V 23BTM	
56	2R-Z18201	4	FOOT 1.69X1 SIL 1/4 20	
57	HC-Z17723	1	TOAST SLIDE	
58	HC-Z17736	1	CRUMB TRAY	
59	2P-Z18587	2	BEARING SPRING 2IN	
60	2P-200700	2	BRG SPRING LOADED	
61	2C-2559	4	NUT 10-24 ACHD BR NP	
62	2M-Z17750	1	LABEL, CROWN	
63	2M-Z17735	1	LABEL, HEEL	
64	HC-CT0009	1	BELT GUARD ASM	
65	2A-CT0016	1	BELT IDLER SHAFT ASSEMBLY	HCTE13M
	2A-CT0016SB			HCTE13S
66	2K-200464	2	BUSHING, WIRE RING 7/8"	
67	2M-Z18258	2	LABEL, SCALE	
68	2A-Z17720	8	SPACER-.375"OD X .192"ID	
69	2V-Z17744	1	PLATEN SUPPORT	
70	HC-CT0012	1	LEFT ADJUSTMENT BRKT ASY	
71	HC-CT0007	2	ELEMENT SUPPORT ASY	
72	HC-Z17731	1	ELEMENT RETAINER	
73	HC-Z17741	1	PANEL, LEFT COVER	

2M-Z19028; Holman Contact Toaster

PARTS LIST

October 13, 2015, Rev. E

Model: HCTE13 & HCT13 Contact Toaster				
Fig No	Part No	Quantity	Description	Application
74	2N-Z17718	1	ELEMENT, METAL 350W 240V	HCTE13S
	2N-Z17718	2	ELEMENT, METAL 350W 240V	HCTE13M
75	2C-1810	16	WASHER 3/16 BURR STL NP	
76	2K-Z17715	2	BUSHING, INNER	
77	HC-Z16924	1	SHAFT ACCESS COVER PLATE	
78	2A-CT0011	2	ADJUSTMENT KNOB ASY	
NI	2E-Z17719	1	TYPE K PROBE	HCTE13
NI	2B-Z17743	1	CONVEYOR BELT CG10 X.062	
NI	PS-CT0034	1	SILICONE BELT, 13" X 41.04	
NI	HA-120244	1	CORDSET ASSY QCS1-230C	230V
NI	HA-120245	1	CORDSET ASSY NEMA 6-20P	208,240V

STAR MANUFACTURING INTERNATIONAL INC.

Star - Holman - Lang - Wells - Bloomfield - Toastmaster

265 Hobson St., Smithville, Tennessee 37166 U.S.A.

(800) 264-7827

www.star-mfg.com