



**Star
Manufacturing
International Inc.**

10 Sunnen Drive
St. Louis, MO 63143

Phone: (314) 781-2777
Fax: (314) 781-2714

**Installation
and
Operating
Instructions**

2M-Y8653 Rev. C 3/19/03

GALAXY POPCORN BASES MODELS GPB-8, GPB-8AT, GPB-14, GPB-14AT



SAFETY SYMBOL



These symbols are intended to alert the user to the presence of important operating and maintenance instructions in the manual accompanying the appliance.

RETAIN THIS MANUAL FOR FUTURE REFERENCE NOTICE

Using any part other than genuine Star factory supplied parts relieves the manufacturer of all liability.

Star reserves the right to change specifications and product design without notice. Such revisions do not entitle the buyer to corresponding changes, improvements, additions or replacements for previously purchased equipment.

Due to periodic changes in designs, methods, procedures, policies and regulations, the specifications contained in this sheet are subject to change without notice. While Star Manufacturing exercises good faith efforts to provide information that is accurate, we are not responsible for errors or omissions in information provided or conclusions reached as a result of using the specifications. By using the information provided, the user assumes all risks in connection with such use.

MAINTENANCE AND REPAIRS

Contact your local authorized service agent for service or required maintenance. Please record the model number, serial number, voltage and purchase date in the area below and have it ready when you call to ensure a faster service.

Model No. _____
Serial No. _____
Voltage _____
Purchase Date _____

Authorized Service Agent

Reference the listing provided with the unit

or

for an updated listing go to:

Website: www.star-mfg.com
E-mail Service@star-mfg.com
Telephone: (800) 807-9054 Local (314) 781-2777

The Star Service Help Desk

Business Hours: 8:00 am to 4:30 p.m. Central Standard Time

Telephone: (800) 807-9054 Local (314) 781-2777

Fax: (800) 396-2677 Local (314) 781-2714

E-mail Parts@star-mfg.com
Service@star-mfg.com
Warranty@star-mfg.com

Website: www.star-mfg.com

Mailing Address: Star Manufacturing International Inc.
10 Sunnen Drive
St. Louis, MO 63143
U.S.A

Carefully unpack the unit and inspect it for any damage.

Check the parts against the attached parts list before starting any assembly. Refer to drawing SK1247 for exploded view of base.

Assemble drop shelf assembly (#2) to body (#1) using (4) 1/4"-20 x 3/8" machine screws (#3a), (4) 1/4" lockwashers (#3c) and (4) 1/4-20 acorn nuts (#3b). Adjustment can be made left or right and up or down before nuts are fully tightened.

INSTALLATION OF MACHINE TO BASE

PREPARATION

Remove kettle from popcorn machine and set it aside out of the way.

Carefully lay the popcorn machine down on its back or sides, on a smooth, flat surface.

NOTE: You may want an assistant for this step.



CAUTION

DO NOT LAY THE POPCORN UNIT ON THE DOORS OR ON AN OBSTRUCTED OR UNEVEN SURFACE AS GLASS BREAKAGE MAY OCCUR.

Remove the (4) rubber plugs from the phenolic feet. Using a phillips screwdriver, remove (1) screw from each foot and replace it with a 10-24x2" collared stud (#3d) in the same position (see SK1247).

NOTE: Approximately 3/8" of thread will protrude from the bottom of each foot.

INSTALLATION

Using an assistant, raise the popper to its upright position. Use caution not to bend or damage the threaded studs.

Move base close to the popper with the open shelves facing in the same direction as the doors on the popper.

Place the sleeve bushing (#3g) into the black plastic bushing on the top panel of the base.

Lace cord set through the sleeve and bushing from top to bottom as far as it will go.

With your assistant's help, carefully pick up the popcorn machine from the bottom. **DO NOT** pick up the machine by grasping the doors, top or other "convenient" hand holds. **NON STRUCTURAL PARTS MAY BE DAMAGED.** Place the popcorn machine on the base with the (4) studs near the mounting holes in the top plate of the base. Be careful not to pinch your hand or fingers between the two units.

NOTE: Placing the popper slightly askew (catty corner) will provide clearance for your hands.

Carefully slide the popper into position on the base until the (4) studs drop through the mounting holes in the top plate. Do not allow the popper to drop too heavily, try to ease it into position one stud at a time. **KEEP FINGERS CLEAR.**

Place (1) flatwasher (#3f) and (1) 10-24 acorn nut (#3e) on each stud protruding through the top plate of the base and tighten.

Replace the kettle assembly, plug in the unit and check for proper operation.

This completes the installation procedure. Occasionally check the mounting nuts since movement may cause them to loosen. Re-tighten as necessary.

MAINTENANCE AND REPAIRS

Contact the factory, a service representative or a local service company for service or required maintenance.

THOROUGHLY INSPECT YOUR UNIT ON ARRIVAL

This unit has been tested for proper operation before leaving our plant to insure delivery of your unit in perfect condition. However, there are instances in which the unit may be damaged in transit. In the event you discover any type of damage to your product upon receipt, you must immediately contact the transportation company who delivered the item to you and initiate your claim with same. If this procedure is not followed, it may affect the warranty status of the unit.

LIMITED EQUIPMENT WARRANTY

All workmanship and material in Star products have a one (1) year limited warranty on parts & labor in the United States and Canada. Such warranty is limited to the original purchaser only and shall be effective from the date the equipment is placed in service. Star's obligation under this warranty is limited to the repair of defects without charge, by the factory authorized service agency or one of its sub-agencies. Models that are considered portable (*see below*) should be taken to the closest Star service agency, transportation prepaid.

- > Star will not assume any responsibility for loss of revenue.
- > On all shipments outside the United States and Canada, see International Warranty.
- * The warranty period for the JetStar six (6) ounce & Super JetStar eight (8) ounce series popcorn machines is two (2) years.
- * The warranty period for the Chrome-Max Griddles is five (5) years on the griddle surface. See detailed warranty provided with unit.
- * The warranty period for Teflon/Dura-Tec coatings is one year under normal use and reasonable care. This warranty does not apply if damage occurs to Teflon/Dura-Tec coatings from improper cleaning, maintenance, use of metallic utensils, or abrasive cleaners, abrasive pads, product identifiers and point-of-sale attachments, or any other non-food object that comes in continuous contact with the roller coating. This warranty does not apply to the "non-stick" properties of such materials.
- > This warranty does not apply to "Special Products" but to regular catalog items only. Star's warranty on "Special Products" is six (6) months on parts and ninety (90) days on labor.
- > This warranty does not apply to any item that is disassembled or tampered with for any purpose other than repair by a Star Authorized Service Center or the Service Center's sub-agency.
- > This warranty does not apply if damage occurs from improper installation, misuse, wrong voltage, wrong gas or operated contrary to the Installation and Operating instructions.
- > This warranty is not valid on Conveyor Ovens *unless* a "start-up/check-out" has been performed by a Factory Authorized Technician.

PARTS WARRANTY

Parts that are sold to repair out of warranty equipment are warranted for ninety (90) days. The part only is warranted. Labor to replace the part is chargeable to the customer.

SERVICES NOT COVERED BY WARRANTY

1. Travel time and mileage rendered beyond the 50 mile radius limit
2. Mileage and travel time on portable equipment (*see below*)
3. Labor to replace such items that can be replaced easily during a daily cleaning routine, i.e; removable kettles on fryers, knobs, grease drawers on griddles, etc.
4. Installation of equipment
5. Damages due to improper installation
6. Damages from abuse or misuse
7. Operated contrary to the Operating and Installation Instructions
8. Cleaning of equipment
9. Seasoning of griddle plates
10. Voltage conversions
11. Gas conversions
12. Pilot light adjustment
13. Miscellaneous adjustments
14. Thermostat calibration and by-pass adjustment
15. Resetting of circuit breakers or safety controls or reset buttons
16. Replacement of bulbs
17. Replacement of fuses
18. Repair of damage created during transit, delivery, & installation OR created by acts of God

PORTABLE EQUIPMENT

Star will not honor service bills that include travel time and mileage charges for servicing any products considered "Portable" including items listed below. These products should be taken to the Service Agency for repair:

- * The Model 510FD Fryer.
- * The Model 526TOA Toaster Oven.
- * The Model J4R, 4 oz. Popcorn Machine.
- * The Model 518CMA & 526CMA Cheese Melter.
- * The Model 12MC & 15MC & 18MCP Hot Food Merchandisers.
- * The Model 12NCPW & 15NCPW Nacho Chip/Popcorn Warmer.
- * All Hot Dog Equipment **except Roller Grills & Drawer Bun Warmers.**
- * All Nacho Cheese Warmers **except Model 11WLA Series Nacho Cheese Warmer.**
- * All Condiment Dispensers **except the Model HPD & SPD Series Dispenser.**
- * All Specialty Food Warmers **except Model 130R, 11RW Series, and 11WSA Series.**
- * All QCS/RCS Series Toasters **except Model QCS3 & RCS3 Series.**

ALL:

- * Pop-Up Toasters
- * Butter Dispensers
- * Pretzel Merchandisers
(Model 16PD-A Only)
- * Pastry Display Cabinets
- * Nacho Chip Merchandisers
- * Accessories of any kind
- * Sneeze Guards
- * Pizza Ovens
(Model PO12 Only)
- * Heat Lamps
- * Pumps-Manual

The foregoing warranty is in lieu of any and all other warranties expressed or implied and constitutes the entire warranty.

FOR ASSISTANCE

Should you need any assistance regarding the Operation or Maintenance of any Star equipment; write, phone, fax or email our Service Department. In all correspondence mention the Model number and the Serial number of your unit, and the voltage or type of gas you are using.

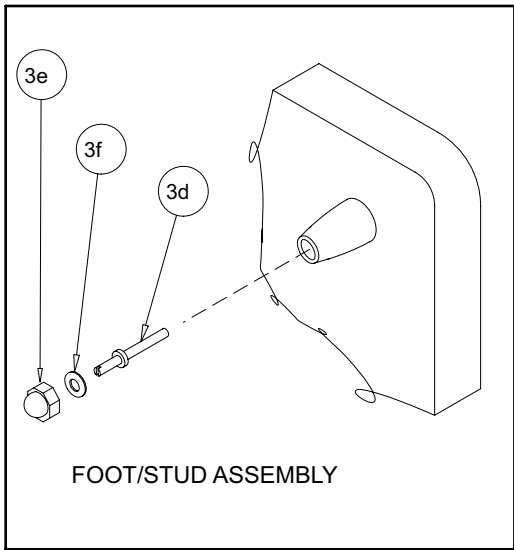
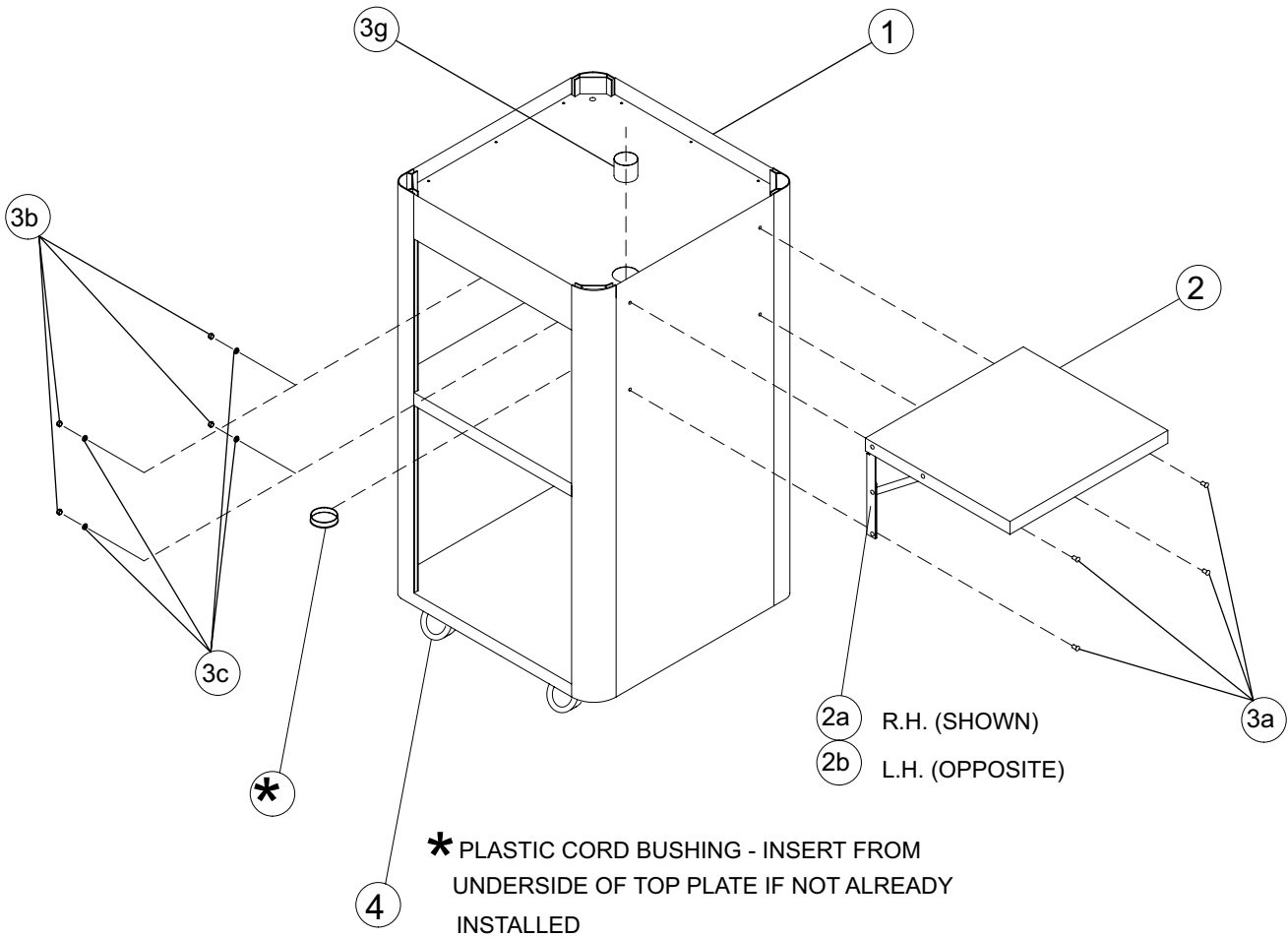

MODEL
GALAXY BASES



STAR MANUFACTURING INTERNATIONAL, INC.

SK1247

Rev. B

12/8/93

PARTS LIST

December 19, 2003, Rev C

Galaxy Popcorn Bases
 MODEL GPB-8, GPB-8AT, GPB-14, GPB-14AT

Key Number	Part Number	Number Per Unit	Description
1		1	BODY ASSEMBLY
2	C3-G8041	1	DROP SHELF ASSEMBLY - 8 OZ. STAINLESS
	C3-G8055	1	DROP SHELF ASSEMBLY - 8 OZ. ANTIQUE
	C3-G8043	1	DROP SHELF ASSEMBLY - 14 OZ. STAINLESS
	C3-G8052	1	DROP SHELF ASSEMBLY - 14 OZ. ANTIQUE
2a	C3-19122	1	SHELF SUPPORT ASSEMBLY R.H
2b	C3-19123	1	SHELF SUPPORT ASSEMBLY L.H.
3a	2C-Y8767	4	1/4-20 x 3/8" R.H. MACHINE SCREW
3b	2C-2581	4	1/4-20 ACORN NUT
3c	2C-1823	4	1/4" SPLIT LOCKWASHER
3d	2C-Y8570	4	10-24 x 2 COLLARED STUD
3e	2C-2559	4	10-24 ACORN NUT
3f	2C-1811	4	1/4" I.D. x .620 DIA. FLAT WASHER
3g	2V-Y8648	1	BUSHING SLEEVE
4	2P-3376	4	CASTER WHEEL

**IMPORTANT: WHEN ORDERING, SPECIFY VOLTAGE OR TYPE GAS DESIRED
 INCLUDE MODEL AND SERIAL NUMBER**

PAGE 1
 OF 1

Some items are included for illustrative purposes only and in certain instances may not be available.



STAR MANUFACTURING

10 Sunnen Drive, St. Louis, MO 63143 U.S.A.

(800) 807-9054 (314) 781-2777

Parts & Service (800) 807-9054

www.star-mfg.com