

# REPLACEMENT PARTS PRICE LIST

MODELS: FFW1, FFW2, FFW3-L; FFW1 BI, FFW2 BI, FFW3 BI-L (120V)  
FFW1, FFW2, FFW3-H; FFW1 BI, FFW2 BI, FFW3 BI-H (208/230V)

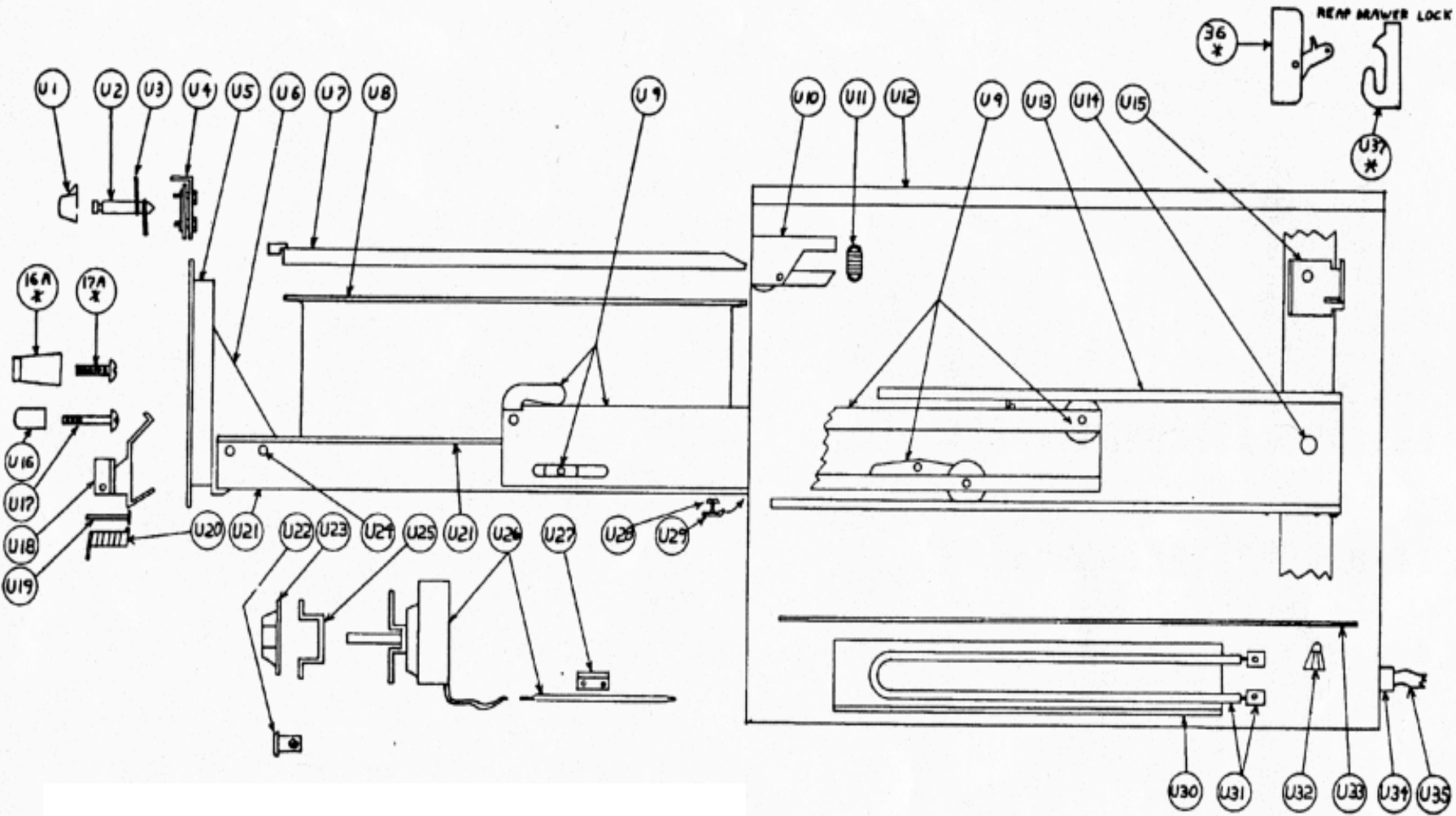

9E MODEL **FFW** Series Drawer Food Warmer

Key Number	Part Number	Number Per Unit	Description	
U1	2R-09-FW-0006	1/2/3/4	MOIST CRISP CONTROL KNOB	FFW1/FFW2/FFW3/FFW4
U2-U4	E9-30-FW-0045	1/2/3/4	MOIST CRISP CONTROL COMPLETE	FFW1/FFW2/FFW3/FFW4
U5	E9-50-FW-0015	1/2/3/4	DRAWER FRONT, STAINLESS, INSULATED	FFW1/FFW2/FFW3/FFW4
U6	E9-04-FW-0111	1/2/3/4	DRAWER SUPPORT ( <b>LEFT</b> )	FFW1/FFW2/FFW3/FFW4
	E9-04-FW-0060	1/2/3/4	DRAWER SUPPORT ( <b>RIGHT</b> )	FFW1/FFW2/FFW3/FFW4
U7	E9-30-FW-0061	1/2/3/4	PAN LID, ALUMINUM	FFW1/FFW2/FFW3/FFW4
U8	2D-09-FW-0016	1/2/3/4	PAN, STAINLESS STEEL (23-1/4 x 14-3/8 x 5-1/8)	FFW1/FFW2/FFW3/FFW4
U9L	E9-30-FW-0039	1/2/3/4	DRAWER SLIDE INNER TRACK ( <b>LEFT</b> )	FFW1/FFW2/FFW3/FFW4
U9R	E9-30-FW-0040	1/2/3/4	DRAWER SLIDE INNER TRACK ( <b>RIGHT</b> )	FFW1/FFW2/FFW3/FFW4
U10,U11	E9-30-FW-0043	1/2/3/4	LID LIFT ASSEMBLY	FFW1/FFW2/FFW3/FFW4
U12	E9-04-FW-0120	1	TOP, STAINLESS STEEL	
U13L	E9-30-FW-0052	1/2/3/4	DRAWER SLIDE OUTER TRACK ( <b>LEFT</b> ) (16-3/16")	FFW1/FFW2/FFW3/FFW4
U13R	E9-30-FW-0053	1/2/3/4	DRAWER SLIDE OUTER TRACK ( <b>RIGHT</b> ) (16-3/16")	FFW1/FFW2/FFW3/FFW4
U14			SCREW ( <b>OBTAIN LOCALLY</b> )	
U15	E9-04-FW-0136	1/2/3/4	LID REST GUIDE ( <b>LEFT</b> )	FFW1/FFW2/FFW3/FFW4
	E9-04-FW-0137	1/2/3/4	LID REST GUIDE ( <b>RIGHT</b> )	FFW1/FFW2/FFW3/FFW4
U16			HANDLE ( <b>OLD STYLE</b> ) ( <b>NO LONGER AVAILABLE</b> )	
U16A	2R-Y7557	1/2/3/4	HANDLE DOOR ( <b>NEW STYLE</b> )	FFW1/FFW2/FFW3/FFW4
U17			HANDLE SCREW ( <b>OBTAIN LOCALLY</b> )	
U17A	2C-08-07-0048	2/4/6/8	HANDLE SCREW (10-32x1.75)	FFW1/FFW2/FFW3/FFW4
U18			DRAWER LOCK ASSEMBLY ( <b>NO LONGER AVAILABLE</b> ) (Use Key # U36 & U37 instead)	
U19			PIN ( <b>NO LONGER AVAILABLE</b> )	
U20	2P-08-07-0151	1/2/3/4	SPRING	FFW1/FFW2/FFW3/FFW4
U21	E9-30-FW-0002	1/2/3/4	DRAWER FRAME ASSEMBLY	FFW1/FFW2/FFW3/FFW4
U22	2S-Z3823	1	ROUND INDICATOR LIGHT (120V) ( <b>NEW STYLE</b> )	
	2S-05-07-0138	1	ROUND INDICATOR LIGHT (240V) ( <b>NEW STYLE</b> )	
	2S-05-07-0040	1	SQUARE INDICATOR LIGHT (120V) ( <b>OLD STYLE</b> ) (not shown)	
	2S-05-07-0170	1	SQUARE INDICATOR LIGHT (240V) ( <b>OLD STYLE</b> ) (not shown)	
U23	2R-09-07-0006	1	THERMOSTAT KNOB	
U25	E9-04-FW-0243	1	THERMOSTAT BRACKET	
U26	2T-05-FW-0003	1	THERMOSTAT, CAPILLARY TUBE TYPE	
U27	E9-04-FW-0131	1	THERMOSTAT BULB CLAMP	
U28			SCREW ( <b>OBTAIN LOCALLY</b> )	
U29	E9-04-FW-0103	1/2/3/4	DRAWER STOP ( <b>LEFT</b> )	FFW1/FFW2/FFW3/FFW4
	E9-04-FW-0313	1/2/3/4	DRAWER STOP ( <b>RIGHT</b> )	FFW1/FFW2/FFW3/FFW4
U30	E9-50-FW-0043	1	ELEMENT HOLDER AND BAFFLE ( <b>LEFT</b> )	
	E9-50-FW-0039	1	ELEMENT HOLDER AND BAFFLE ( <b>RIGHT</b> )	
U31	2N-05-FW-0002	2	ELEMENT, 600 WATT (120/208/240V)	
U32	2C-05-07-0036	2	PORCELAIN WIRE CONNECTOR ( <b>OLD STYLE</b> )	
	2E-05-07-0057	1	TERMINAL BLOCK ( <b>NEW STYLE</b> ) (not shown)	
U33	E9-04-FW-0115	1	ELEMENT COVER PLATE	
U34	2K-05-07-0017	1	STRAIN RELIEF, CORDSET	
U35	2E-05-07-0051	1	LEAD-IN CORD (120V)	
	2E-05-07-0049	1	LEAD-IN CORD (240V)	
U36	E9-30-FW-0044	1/2/3/4	REAR DRAWER LOCK	FFW1/FFW2/FFW3/FFW4
U37	E9-70-FW-0093	1/2/3/4	DRAWER LOCK CATCH	FFW1/FFW2/FFW3/FFW4
	2P-09-FW-0025	2	RIGID WHEEL/CASTER (not shown)	
	2P-09-FW-0026	2	SWIVEL WHEEL/CASTER (not shown)	
	2A-09-FW-0023	4	LEG 6" (not shown)	
	2A-09-FW-0024	4	LEG 12" (not shown)	
	2T-05-FW-0004	1	THERMOMETER FLANGE FRONT ( <b>OLD STYLE</b> ) (not shown)	
	2T-05-FW-0010	1	THERMOMETER 2" DIAL ( <b>NEW STYLE</b> ) (not shown)	

IMPORTANT: WHEN ORDERING, SPECIFY VOLTAGE OR TYPE GAS DESIRED  
INCLUDE MODEL AND SERIAL NUMBER

PAGE 1  
OF 1

Some items are included for illustrative purposes only and in certain instances may not be available.



Star Manufacturing International, Inc.