

Central[®]

RESTAURANT PRODUCTS

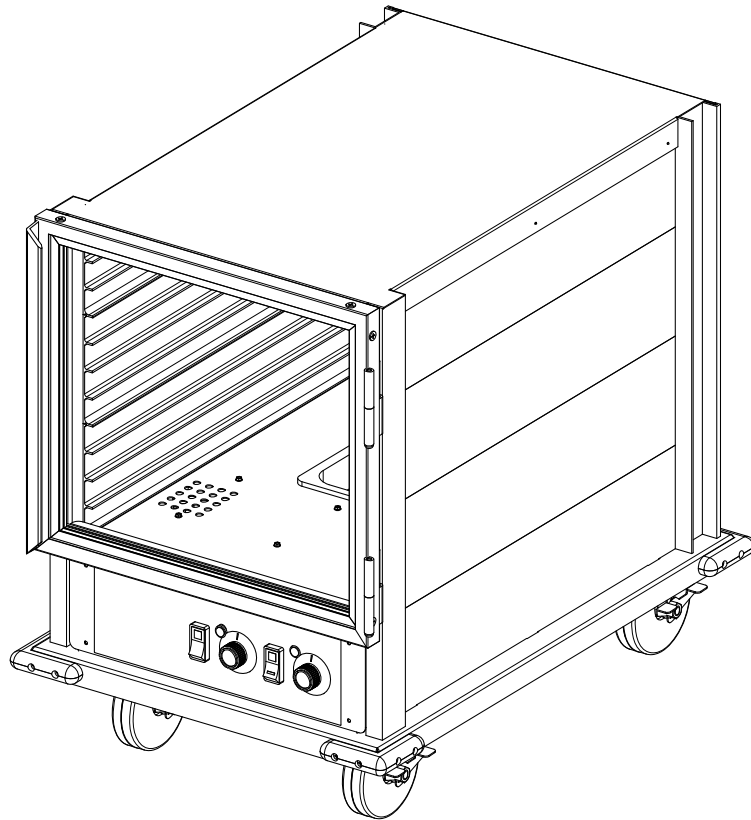

HEATER PROOFERS

MODEL

(E)9451-12CDCP, (E)9451-12SDCP,
(E)9451-34CDCP, (E) 9451-34CDCP

Installation, Operation & Parts Manual

2M-Z18494 Rev. - May 12, 2014

SAFETY SYMBOL



These symbols are intended to alert the user to the presence of important operating and maintenance instructions in the manual accompanying the appliance.



RETAIN THIS MANUAL FOR FUTURE REFERENCE NOTICE

Using any part other than genuine Star factory supplied parts relieves the manufacturer of all liability.

Star reserves the right to change specifications and product design without notice. Such revisions do not entitle the buyer to corresponding changes, improvements, additions or replacements for previously purchased equipment.

Due to periodic changes in designs, methods, procedures, policies and regulations, the specifications contained in this sheet are subject to change without notice. While Star International Holdings Inc., Company exercises good faith efforts to provide information that is accurate, we are not responsible for errors or omissions in information provided or conclusions reached as a result of using the specifications. By using the information provided, the user assumes all risks in connection with such use.

MAINTENANCE AND REPAIRS

Contact your local authorized service agent for service or required maintenance.

Please record the model number, serial number, voltage and purchase date in the area below and have it ready when you call to ensure a faster service.

Model No. _____

Serial No. _____

Voltage _____

Purchase Date _____

Authorized Service Agent Listing

Reference the listing provided with the unit

OR

for an updated listing go to:

Website: www.star-mfg.com
E-mail Service@star-mfg.com

Service Help Desk

Business Hours: 8:00 am to 4:30 p.m. Central Standard Time

Telephone: (314) 678-6303

Fax: (314) 781-2714

E-mail Parts@star-mfg.com
Service@star-mfg.com
Warranty@star-mfg.com

Website: www.star-mfg.com

Mailing Address: Star International Holdings Inc., Company
10 Sunnen Drive
St. Louis, MO 63143
U.S.A

2M-Z18494, Heater Proofer 9451 - Series

9451 HP SERIES SERVICE SPECIFICATIONS

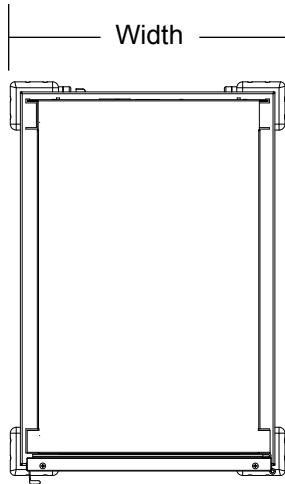

Top

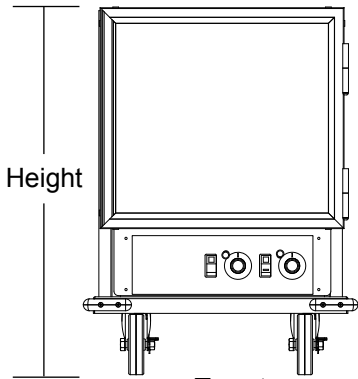

Front

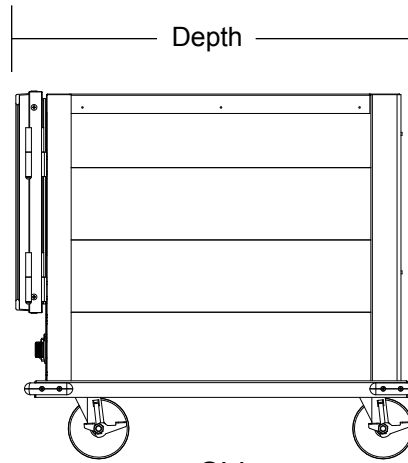

Side

IL2431

The Heater Proofer is an aluminum transport cabinet with heaters to function as a hot food holding cabinet, and/or as a proofing cabinet.

The heater, or heat drawer, is slid into place on the floor of the cabinet. An electrical socket on the back of the drawer is provided to accept the supplied power cord, which is plugged into the drawer through an access hole in the back of the cabinet.

The main power switch on the front of the drawer, when switched "ON", will turn on the light in the switch and turn on the air circulating fan in the drawer. The circulating fan will operate continuously while the unit is "ON".

The thermostat control knobs are mounted to the left and right of the heat/proof switch. The left thermostat knob controls the heat in the cabinet from 1 (low heat: approximately 80°F) to 9 (high heat: approximately 185°F). The right thermostat knob controls the humidity from 1 (approximately 20% relative humidity) to 9 (in excess of 100% relative humidity). Average setting will be approx. 6 (approximately 85% relative humidity).

SIZE SPECIFICATIONS

	Exterior			Interior			Weight Shipping
	Height	Width	Depth	Height	Width	Depth	
9451-12	30.3125"	22.8125"	33.3125"	15.625"	18.125"	27.5"	100lbs
9451-34	67.5625"	23.3125"	33.875"	51.75"	18.125"	27.5"	140lbs

ELECTRICAL SPECIFICATIONS

Model	Volts	Watts	Phase	Hz	NEMA
9451-12CDCP	120V	1.5 kW	1	50/60 Hz	5-20P
9451-12SDCP					
9451-34CDCP					
9451-34SDCP					
E9451-12CDCP					
E9451-12SDCP					
E9451-34CDCP					
E9451-34SDCP					

2M-Z18494, Heater Proofer 9451 - Series



This equipment is designed to hold food at a constant temperature, and supply humidity for proofing when the application applies, this is NOT a cooking appliance. This unit is sold for commercial use only by personnel trained and experienced in its operation and is not sold for consumer use in and around the home nor for use directly by the general public in food service locations.

Before using your new equipment, read and understand all the instructions & labels associated with the unit prior to putting it into operation. Make sure all people associated with its use understand the units operation & safety before they use the unit.

All shipping containers should be checked for freight damage both visible and concealed. This unit has been tested and carefully packaged to insure delivery of your unit in perfect condition. If equipment is received in damaged condition, either apparent or concealed, a claim must be made with the delivering carrier.

Concealed damage or loss - if damage or loss is not apparent until after equipment is unpacked, a request for inspection of concealed damage must be made with carrier within 15 days. Be certain to retain all contents plus external and internal packaging materials for inspection. The carrier will make an inspection and will supply necessary claim forms.

INSTALLATION

This unit is equipped for the voltage indicated on the nameplate mounted the side of the unit. They will operate on alternating current (AC) only.

The electrical connection must be made in accordance with local codes or in the absence of local codes with NFPA No.70 latest edition (in Canada use: CAS STD. C22.1). The electrical service is provided by a cord and plug. Each appliance requires a 120 volt grounded supply. Supply wires must be 14 gauge or larger to carry the load for one proofer.



DO NOT CONNECT TO DIRECT CURRENT (DC).

THIS APPLIANCE IS EQUIPPED WITH A 3-PRONG (GROUNDED) PLUG FOR YOUR PROTECTION AGAINST SHOCK HAZARD AND MUST BE PLUGGED DIRECTLY INTO A PROPERLY GROUNDED 3-PRONG RECEPTACLE.

GENERAL OPERATING PROCEDURES

Proofing

Proofing is one of the most important and delicate stages in baking. About 50% of the product volume is created in the proofer. Proofing accelerates the fermentation of yeast in a warm moist environment causing the dough to rise. The proofer humidity should be between medium high and high. For optimum results, rolls should be removed from the hot proofer and transferred to the cold proofer at minimum proof. This will ensure that they can be held for 40 minutes without becoming over-proofed.

OPERATING INSTRUCTIONS

Startup

1. Push ON/OFF rocker switch to "ON" position
2. Push HEAT/PROOF switch to HEAT for heating.
3. Turn HEAT thermostat knob fully clockwise for pre-heat.
4. Allow 45 minutes for pre-heating, then turn thermostat to desired setting.
5. For proofing, push HEAT/PROOF switch to PROOF. **DO NOT RUN WATER PAN EMPTY.**

Note: While in proof mode only the element around the water pan is on.

6. Adjust the heat and humidity thermostat knobs to control desired temp and humidity. 45 min pre-heating.

Note: The internal air circulation blower will operate continuously when the power switch is turned "ON".

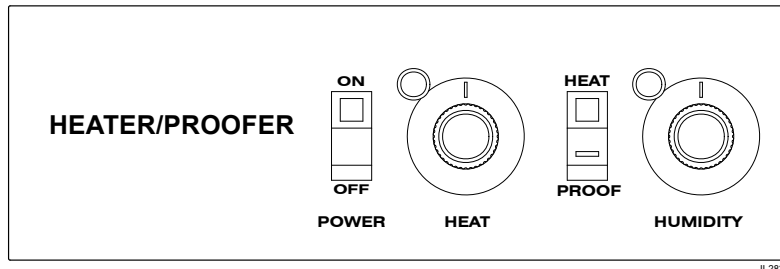

Heat Knob (Heat Mode)

The controlling range is 80° to 185°F (26° to 85°C) temperatures vary slightly between insulated and non-insulated units. The dial has setting from 1 to 9 that do not relate to any specific calibrated temperatures. Temperature settings must be obtained through familiarization with the unit. While in the heat mode this knob controls the two elements in the air stream, in the "OFF" position the elements are turned off. During the "Proof" mode one of these elements is not in use.

Humidity Knob (Proof Mode)

To control the humidity range from 30% to 100% humidity, settings must be obtained through familiarization with the unit. The dial has a range of 1 - 9 which determines the temperature of the water in the pan, if you have the knob in the "OFF" position it will turn the proofing element off. While in proof mode the unit will operate at a lower temperature.

Allow 45 minutes to pre-heat in both heat & proof cycle.

TROUBLESHOOTING

CAUTION: Before disassembling unit, electrical power must be disconnected by unplugging the unit. Failure to unplug the unit prior to servicing may result in electrical shock.

Each unit is shipped with an instruction manual to be used as a reference guide for all service areas. The manual shows a picture of the drawer, showing the location of electrical components and a description of each. If the unit does not operate correctly, or malfunctions for any reason, the following checklist should provide a solution.

- 1) Check to make sure cord set is firmly plugged into the power receptacle in the back of the cabinet and into the wall outlet.
- 2) Check circuit breaker of wall outlet and reset if necessary.
- 3) Remove heat drawer from cabinet. Remove bottom cover of drawer. Visually inspect for:
 - a) Loose or disconnected wires
 - b) Black marks or burning on any components
 - c) Loose heating elements.
- 4) If any burn marks or discoloration of wires is note on any components along with all wires attached to damaged components must be replaced.
- 5) If heater element is loose, or if it has broken loose from mounting tabs, the wires will short out on the Metal, causing permanent damage. Both the element and main power switch (with wires on switch) must be replaced.
- 6) If temperature on "L.E.D. Thermometer" is not reading a constant temperature, it must be replaced. If temperature has exceeded 200°F (93°C) it must be lowered immediately to maximum temperature of 185°F (85°C).

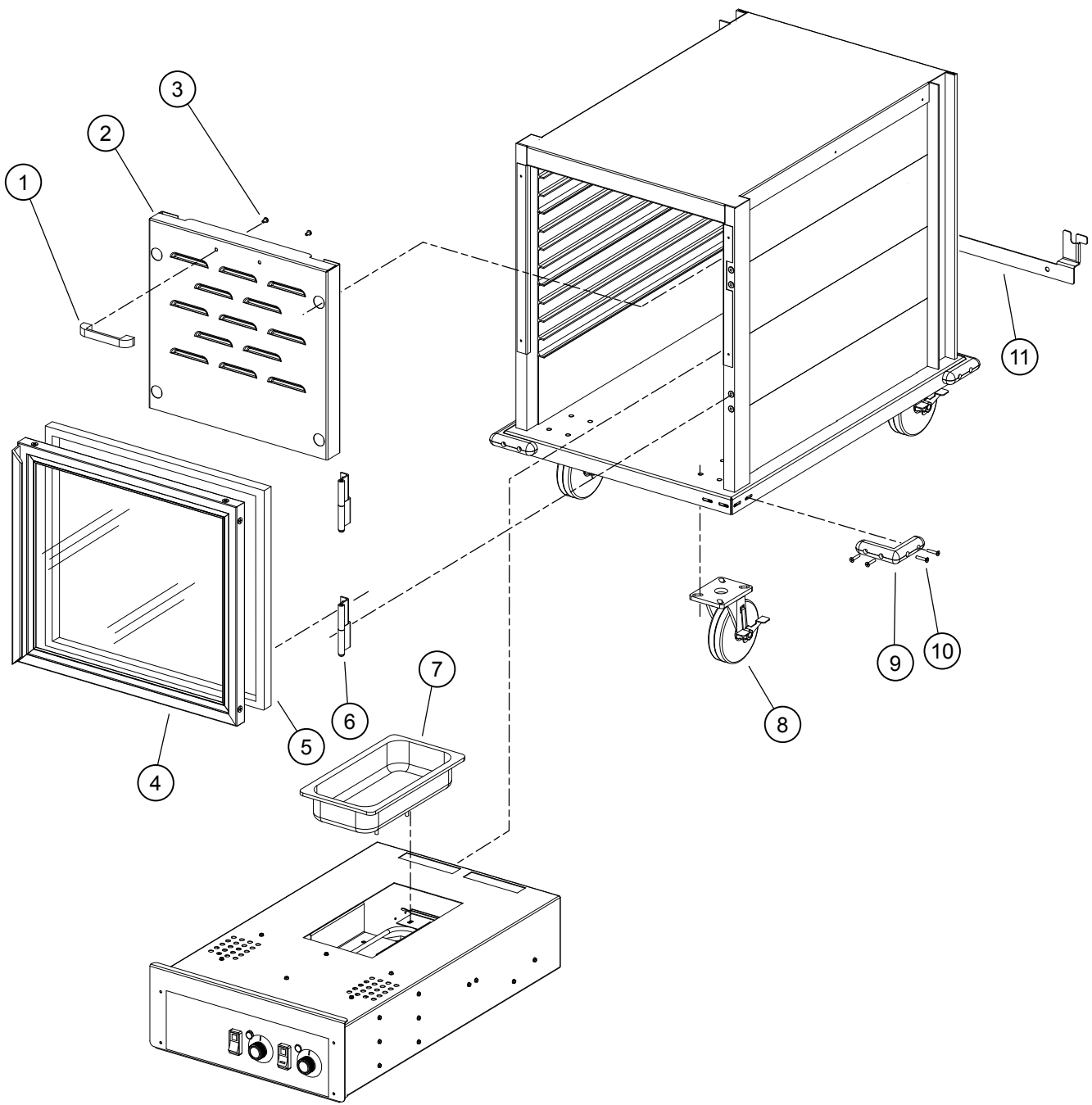

See Detail A

Model: E9451 Heater / Proofer

Central[®]
RESTAURANT PRODUCTS

SK2778

Rev. -

5/09/2012

2M-Z18494, Heater Proofer 9451 - Series

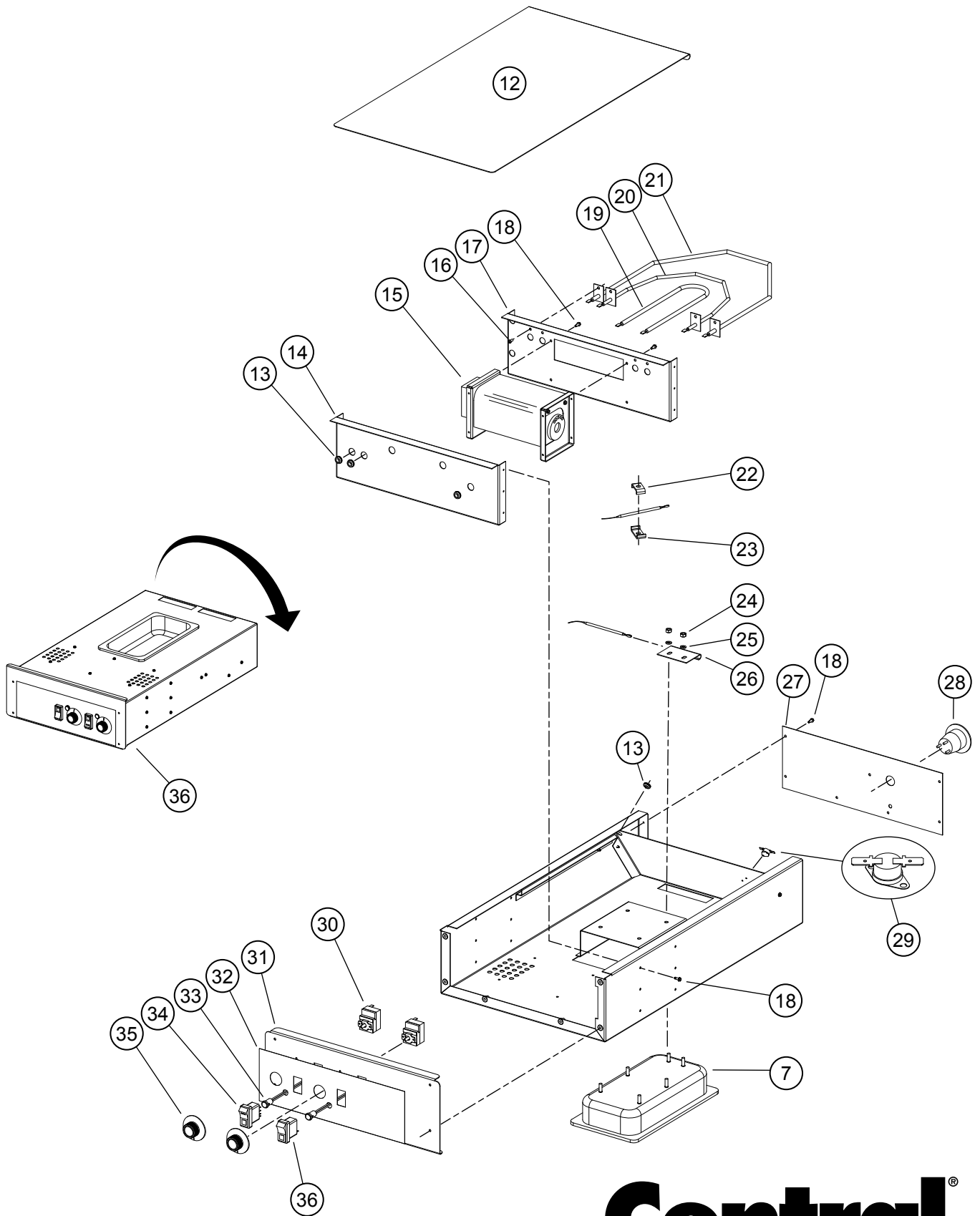

Detail A

Model: E9451 Heater / Proofer

Central[®]
RESTAURANT PRODUCTS

SK2779

Rev. -

5/09/2014

PARTS LIST

March 12, 2014, Rev. -

Central Products: Heater / Proofer Model: E9451 & 9451				
Fig No	Part Number	Qty	Description	Application
1	2R-4FM0705P	1	PULL,ALM DRWR,DIE CST,BUF	
2	R2-AC1323	1	BAFFLE	9451-12CDCP, 9451-12SDCP, E9451-12CDCP, E9451-12SDCP
	R2-WH2006			9451-34CDCP, 9451-34SDCP, E9451-34CDCP, E9451-35SDCP
3	2C-1525	2	SCREW 1/4-20X1-1/4 RH ST	
4	R2-WASSY001	1	ASSY,DOOR,CLEAR,NHPL-1836	9451-34CDCP, E9451-34CDCP
	R2-WASSY003		ASSY,DOOR,SOLID,NHP-1836	9451-34SDCP, E9451-34SDCP
	R2-WASSY022		ASSY,DOOR,RH,E9451-HP12CD	9451-12CDCP, E9451-12CDCP
	R2-WASSY057		ASSY,DOOR,RH, SOLID DOOR	9451-12SDCP, E9451-12SDCP
5	2I-4FMD345P	1	18.63X52.70 GSK, BLK, MAG	E9451-34, 9451-34
	2I-4FMD405P		GASKET,BLK,MAG,18.63X16.5	E9451-12, 9451-12
6	2V-4FM0003P	2	HINGE,ASSY,2",S/S	
7	R2-TC0075	1	PAN ASSY.	
8	2P-738ABK	4	CASTER,5x1.25,SWIVEL,POLY	
9	2R-4FMBC01P	4	CORNER BUMPER J-J-B12 BLA	
10	2C-Z15625	16	SCREW 10-32-1 FLT HD PHIL	
11	R2-Z17184	1	CORD BRACKET	
12	R2-WH2020	1	BOTTOM COVER	
13	2I-6STRN05P	6	GROMMET,7/16X1/16X1/4X3/4	
14	R2-WH2014	1	ELECT BULKHEAD	
15	2U-WP-6FANS30P	1	6IN TRANSFLOW FAN 115V/60	
16	2C-1493	7	SCREW 8-32X3/8 RHP STL NP	
17	R2-WH2015	1	BULKHEAD, MOTOR	
18	2C-8833	37	SCREW 8-18X1/2 HEX STL NP	
19	2N-6FME755P	1	ELEMENT,120V,600W	
20	2N-6WH0001P	1	ELEMENT,HTPRF 600W/120V	
21	2N-6WH0002P	1	ELEMENT,HTPRF 900W	
22	R2-WH2022	1	PROBE HOLDER TOP	
23	R2-WH2023	1	PROBE HOLDER BOTTOM	
24	2C-2582	7	NUT 1/4-20 HEX STL NP	
25	2C-Z5557	7	WASHER 1/4 SPLIT SS	
26	R2-AP2102	1	PROBE HOLDER	
27	R2-WH2012	1	REAR COVER PLATE	
28	2E-50-1382	1	OUTLET,NEMA 5-20R	
29	2T-66-1150	1	DISC,SNAP,275°F	
30	2T-66-1121	2	THERMOSTAT,85-180 DEG,MEC	
31	R2-AC2337	1	FRONT CONTROL PNL	
32	2M-Z18490	1	GRAPHIC, HEATPROOF	
33	2J-50-0029	2	LIGHT,PILOT,RED NEON,125V	
34	2E-50-1355	1	SWITCH,ROCKER,SPST,ON-OFF	Main Power Switch
35	2R-50-0726	2	KNOB,TEMP.BOARD CONTROL	
36	2E-50-1357	1	SWITCH,ROCKER,DPDT,ON-ON	Heat / Proof Select Switch
37	R2-TC0092	1	HP MODULE	
NI	2C-20304-02	1	NUT WING 1/4-20 STN STL	
NI	2E-6WH0040P	1	CORD,POWER,6'FT LONG H-10	
NI	2C-Z15532	1	CABLE CLAMP	
NI	R2-AC1330	1	SIDE, OUTER RIGHT	9451-12CDCP, 9451-12SDCP
NI	R2-AC1331	1	SIDE, OUTER LEFT	9451-12CDCP, 9451-12SDCP
NI	R2-AC2515	1	SIDE-O/D-LT	9451-34CDCP, 9451-35SDCP
NI	R2-AC2516-C	1	SIDE-O/D-RT	9451-35CDCP, 9451-34SDCP

2M-Z18494, Heater Proofer 9451 - Series

2M-Z18494, Heater Proofer 9451 - Series

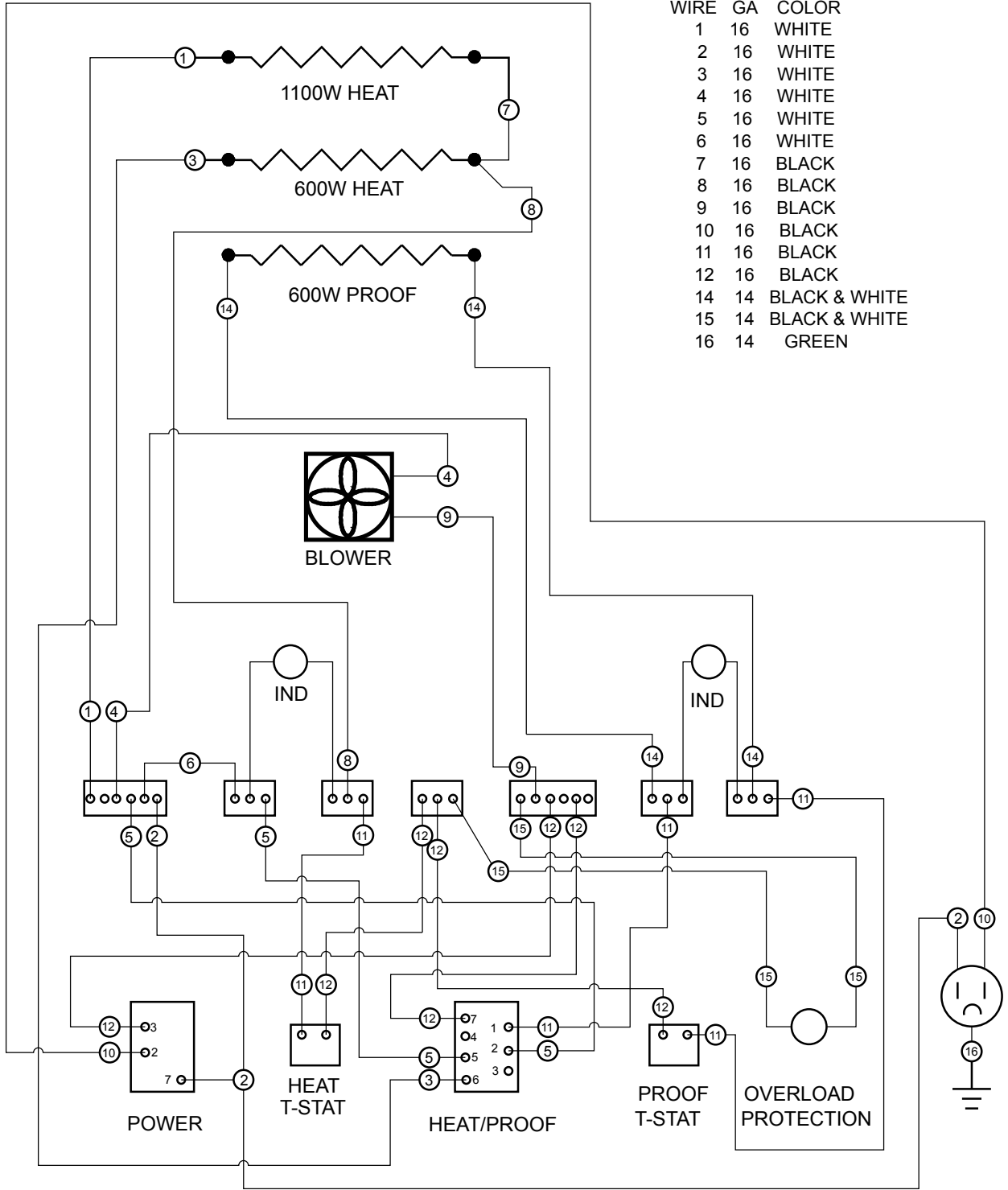

WIRE	GA	COLOR
1	16	WHITE
2	16	WHITE
3	16	WHITE
4	16	WHITE
5	16	WHITE
6	16	WHITE
7	16	BLACK
8	16	BLACK
9	16	BLACK
10	16	BLACK
11	16	BLACK
12	16	BLACK
14	14	BLACK & WHITE
15	14	BLACK & WHITE
16	14	GREEN

HEATER PROOFER
WIRING DIAGRAM

Central[®]
RESTAURANT PRODUCTS

SK2780

REV. -

5-09-14

