

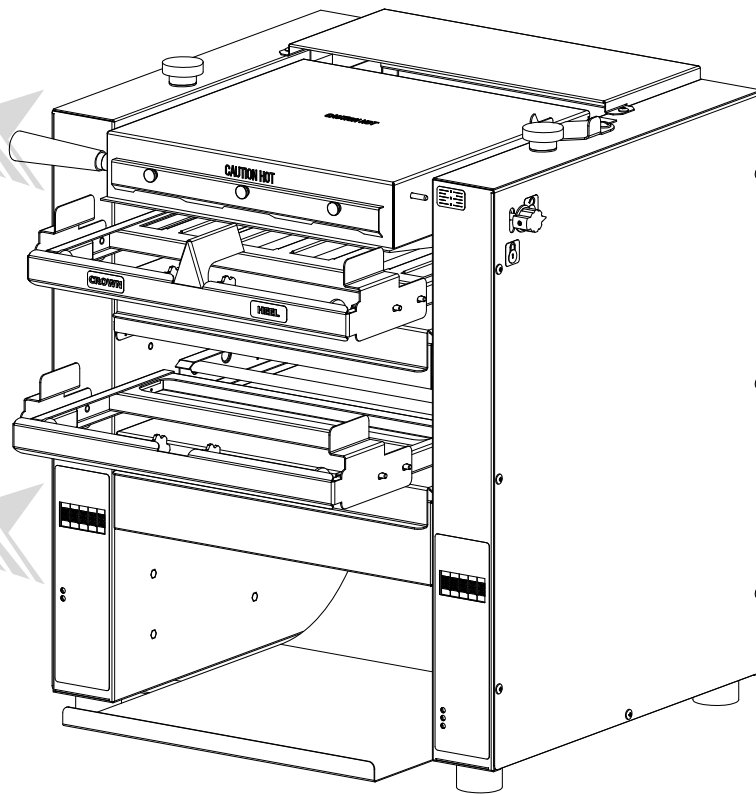

# CONTACT & RADIANT TOASTER

## MODEL CRT14E SERIES Installation and Operation Instructions

2M-Z20664 Rev. B 10/19/15



CRT14E

## SAFETY SYMBOL



These symbols are intended to alert the user to the presence of important operating and maintenance instructions in the manual accompanying the appliance.

---

## RETAIN THIS MANUAL FOR FUTURE REFERENCE NOTICE

Using any part other than genuine Star factory supplied parts relieves the manufacturer of all liability.

Star reserves the right to change specifications and product design without notice. Such revisions do not entitle the buyer to corresponding changes, improvements, additions or replacements for previously purchased equipment.

Due to periodic changes in designs, methods, procedures, policies and regulations, the specifications contained in this sheet are subject to change without notice. While Star International Holdings Inc., Company exercises good faith efforts to provide information that is accurate, we are not responsible for errors or omissions in information provided or conclusions reached as a result of using the specifications. By using the information provided, the user assumes all risks in connection with such use.

## MAINTENANCE AND REPAIRS

Contact your local authorized service agent for service or required maintenance.

Please record the model number, serial number, voltage and purchase date in the area below and have it ready when you call to ensure a faster service.

Model No. \_\_\_\_\_  
Serial No. \_\_\_\_\_  
Voltage \_\_\_\_\_  
Purchase Date \_\_\_\_\_

### Authorized Service Agent Listing

Reference the listing provided with the unit

OR

for an updated listing go to:

**Website:** [www.star-mfg.com](http://www.star-mfg.com)  
**E-mail** [customerservice@star-mfg.com](mailto:customerservice@star-mfg.com)

### Service Help Desk

**Business Hours:** 8:00 am to 4:30 p.m. Central Standard Time

**Telephone:** (314) 678-6303

**Fax:** (314) 781-2714

**E-mail** [customerservice@star-mfg.com](mailto:customerservice@star-mfg.com)

**Website:** [www.star-mfg.com](http://www.star-mfg.com)

**Mailing Address:** Star International Holdings Inc., Company  
10 Sunnen Drive  
St. Louis, MO 63143  
U.S.A

# TABLE OF CONTENTS

- Specifications . . . . . 1**
- Features & Benefits . . . . . 2**
- General Information**
  - Uncrating And Inspecting . . . . . 3
  - Electrical Connection . . . . . 3
- Assembly & Installation**
  - Crumb Trays . . . . . 4
  - Toaster Settings . . . . . 4
- Contact Toaster Daily Operation**
  - Change Temperature . . . . . 5
  - Change Conveyor Speed . . . . . 5
  - Check Temperature Setting . . . . . 5
  - Clean Mode . . . . . 5
  - Changing Bun Thickness . . . . . 5
- Radiant Toaster Daily Operation . . . . . 6**
  - Start Up . . . . . 6
  - Daily Operation . . . . . 6
  - Power Saver Mode. . . . . 6
- Daily Operation. . . . . 7**
- Cleaning . . . . . 7-8**
- Maintenance Procedures . . . . . 9-10**
- Removing & Replacing Silicone Belt . . . . . 11**
- Warranty . . . . . 12**
- Wiring Diagram. . . . . 13**
- Exploded View & Parts List . . . . . 14-16**

## SPECIFICATIONS

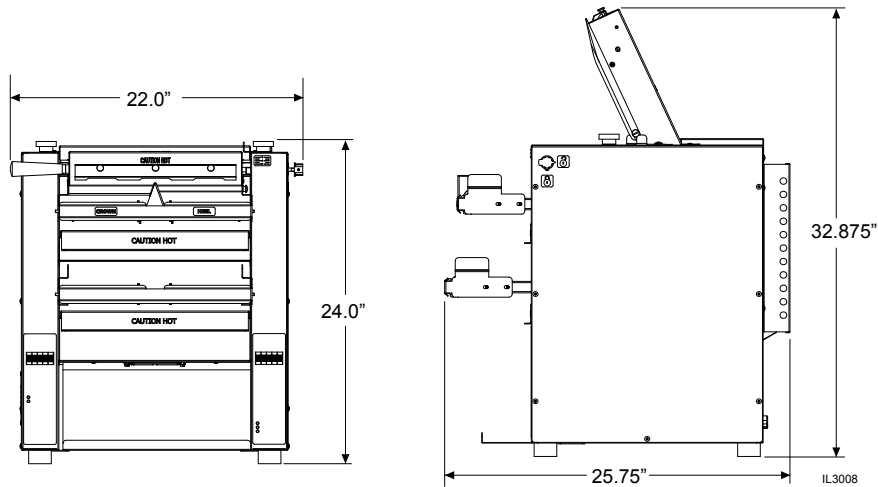

### ELECTRICAL SPECIFICATIONS

Model No.	Volts	Hz	Phase	Amps	Watts	Plug
CRT14EM	208V	60	1	23.75	4,940	6-30P
	240V			23	5520	
CRT14ES	208V			23.75	4,940	
	240V			23	5520	

2M-Z20664; Contact & Radiant Dual Toaster

# FEATURES & BENEFITS

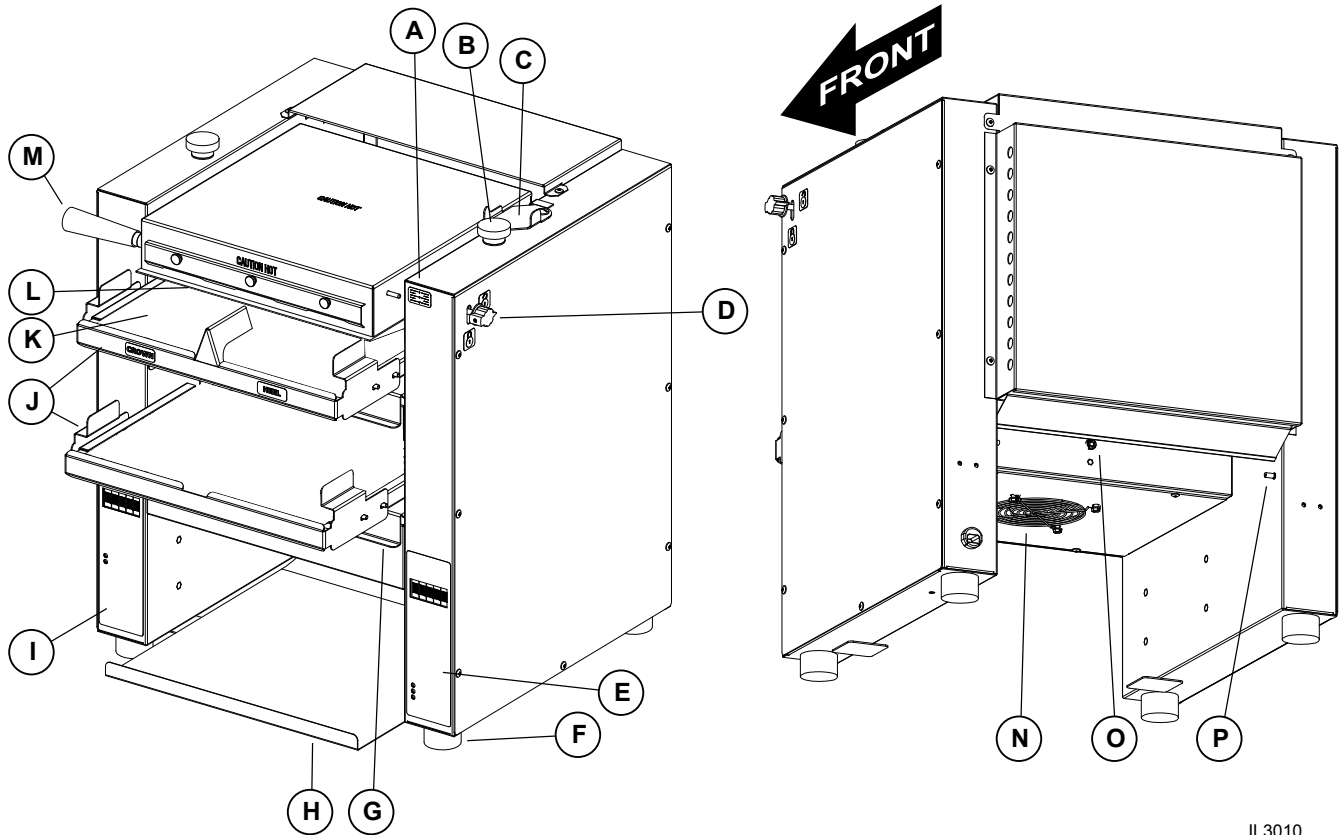

IL3010

A	Platen Height Indicator	Indicates the height of the upper platen
B	Platen Height Knob	Controls the height of the upper platen
C	Platen Support Bracket	Keeps the upper platen in the up position, useful while cleaning
D	Locking Platen Latch	Keeps the upper platen in the down position.
E	Control Board Radiant	Controls the conveyor speeds, turns lower section on & off & temperature settings
F	Foot	Silicone foot keeps unit firmly in place.
G	Crumb Tray	Slide out crumb tray used to catch particles from falling
H	Toaster Chute	Removable Chute returns product for easy access. Can be easily removed for cleaning.
I	Control Board Contact	Controls the conveyor speeds, turns upper section on & off & temperature settings
J	Burn Guard	Protects users from touching the conveyor belt
K	Conveyor	Takes the heel and crown separately through their toasting process
L	Durable Non-Stick Coated Sheet	Non-Stick surface between the upper platen and the product, allowing the product to slide easily through the toasting process.
M	Upper Platen Assy	Heating surface designed to toast the product as it slides across the surface
O	High Limit	Interrupts the heater tube connections if the air temperature in the control box exceeds 190°F (88°C). This limit switch can be reset manually by pushing the button in the center of the switch.
N	Cooling Fan	Brings cool air into the control box and prevents unit from overheating
P	Mounting Pin, Toaster Chute	Holds the Chute in place.

2M-Z20664; Contact & Radiant Dual Toaster

## GENERAL INSTALLATION DATA



This equipment is designed and sold for commercial use only by personnel trained and experienced in its operation and is not sold for consumer use in and around the home nor for use directly by the general public in food service locations.

Before using your new equipment, read and understand all the instructions & labels associated with the unit prior to putting it into operation. Make sure all people associated with its use understand the units operation & safety before they use the unit.

All shipping containers should be checked for freight damage both visible and concealed. This unit has been tested and carefully packaged to insure delivery of your unit in perfect condition. If equipment is received in damaged condition, either apparent or concealed, a claim must be made with the delivering carrier.

Concealed damage or loss - if damage or loss is not apparent until after equipment is unpacked, a request for inspection of concealed damage must be made with carrier within 15 days. Be certain to retain all contents plus external and internal packaging materials for inspection. The carrier will make an inspection and will supply necessary claim forms.

### INSPECTION & ASSEMBLY

#### UNCRATING AND INSPECTING

Unpack the unit and components from the shipping container. Remove all visible packing material and those from inside the cooking chamber. If damage is discovered, file a claim immediately with the carrier that handled the shipment. Do not operate the unit if it was damaged during shipping.



Allow enough space around the toaster for adequate ventilation. Do not operate the unit without the crumb tray properly positioned. Overheating and poor toasting may occur. Read all labels on the unit and follow their instructions.



#### ELECTRICAL CONNECTION

Before making any electrical connection to this unit, check that the power supply is adequate for the voltage, amperage and requirements stated on the rating plate. A wiring diagram is included with the unit.

Disconnect the unit from the power source before installing or removing any parts.

Be absolutely sure that the ground connection for the receptacle is properly wired. Do not connect equipment to power without proper ground connections. Improper grounding may result in personal injury or fatality.



**DO NOT CUT OR REMOVE THE SUPPLIED PLUG OR GROUNDING PRONG FROM THE PLUG.**

**CONNECT/PLUG UNIT INTO DEDICATED A.C. LINE ONLY SPECIFIED ON THE DATA PLATE OF THE UNIT.**

**MAKE SURE ALL INPUT IS OFF OR THAT THE UNIT IS DISCONNECTED FROM THE POWER SUPPLY BEFORE INSTALLING OR REMOVING ANY PART.**

**BEFORE INSTALLING UNIT (S), CHECK WITH LOCAL POWER COMPANY TO DETERMINE ACTUAL VOLTAGE AT THE JOB SITE. NEVER PLUG A 208-VOLT UNIT INTO 240-VOLTS OR A 240-VOLT UNIT INTO A 208-VOLT.**

**BE SURE THE GROUND CONNECTION FOR THE RECEPTACLE IS PROPERLY WIRED. NEVER CONNECT UNIT TO POWER WITHOUT PROPER GROUND CONNECTIONS. IMPROPER GROUND MAY RESULT IN SEVERE INJURY OR FATALITY.**

## ASSEMBLY AND INSTALLATION

The unit was shipped fully assembled and ready to plug into a 6-30R receptacle. If improper electrical supply is determined, contact a qualified electrician prior to using the unit. Removal and replacement of the power cord and plug will void the warranty. For assistance, contact your local authorized service agent for service or required maintenance. Refer to the Authorized Service Agent Listing that was supplied with unit, or go to the inside cover to find out how to obtain one.

1. Place the unit in its operating location and level unit using the adjustable feet under the unit (approx. 1/2" adj.).
2. Wipe down the exterior with a damp cloth.
3. Place the Toaster Chute & Crumb Tray into position.
4. Unlock the Platen Latch and raise the platen, move the Platen Support Bracket to hold the platen in the up position.
5. Loosen the Sheet Retainer and install the non-stick sheet into position, and secure.
6. Lower the Platen and latch in place.

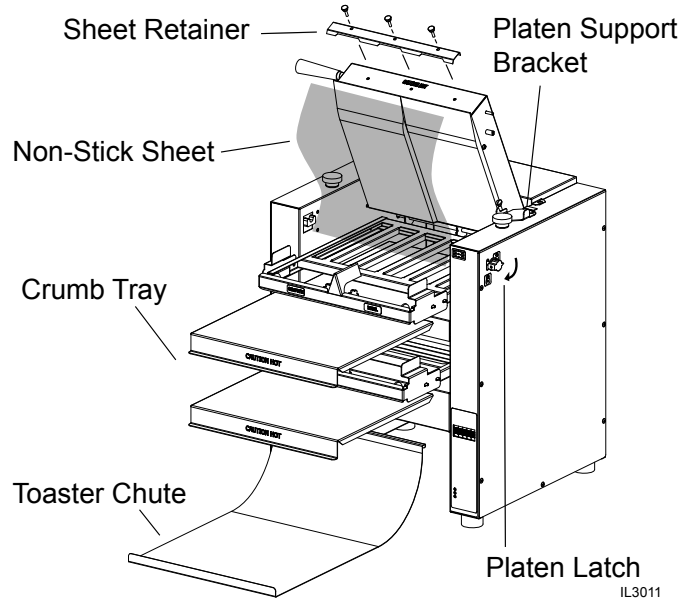

### CRUMB TRAYS

The CRT14 is equipped with two (2) crumb trays that are positioned under each conveyor. Operating the unit without the crumb trays will cause it to operate at a higher temperature which will lead to unit shutting down. Be sure to wipe the crumb trays clean using a damp cloth, each day.



Failure to use non-stick sheets can lead to damaging the unit and a loss of warranty. The durable non-stick coated sheets are not a warranty item.

### TOASTER SETTINGS

Before using the unit for the first time, test the pass time of the conveyor belt.

The pass time through the toaster should be between 16 to 20 seconds for standard setting.

1. Turn unit ON and wait for it to complete the PRE-HEAT process.
2. Set the Platen height by adjusting the two (2) Platen Height Knobs on top of the unit.
3. Make sure the platen lock is on.
4. Place a bun on the conveyor belt, cut side up, "HEEL" on one side and "CROWN" on the other.

**IF TO DARK: Decrease TEMP.**

**IF TO LIGHT: Increase TEMP. or lower platen**

# CONTACT TOASTER DAILY OPERATION ELECTONIC CONTROL

## CHANGING TEMPERATURE

1. Push and hold the "SET TEMP" button for three seconds.
2. The display will flash the current top temperature setting.
3. Using the ↑ and ↓ adjust the top heat to desired temperature (increments of 10°)
4. Press the "SET TEMP" button again to change the bottom heat setting.
5. Using the ↑ and ↓ adjust the bottom heating setting (0 – 10).
6. Press the "SET TEMP" button again to save the settings and exit program mode.

## CHANGING CONVEYOR SPEED

1. Push and hold the ↑ and ↓ for three seconds
2. Using the ↑ and ↓ adjust the motor speed to the desired setting (1 through 99)
3. Press the "SET TEMP" button to exit the program

## CHECK TEMPERATURE SETTING

1. Press the "SET TEMP" button to check the platen temperature.

## CLEAN MODE

1. Press the "CLEAN" button to enter the clean mode
  - a. Elements will be turned OFF and the belt will continue to run
  - b. The screen will flash CLEAN and WAIT.
  - c. When the platen has lowered to a safe temperature the screen will flash CLEAN and READY.
2. Press the "ON/OFF" button to exit the clean mode.

## CHANGING BUN THICKNESS SETTING

1. Set the "Height Adjustment Knobs" to their desired settings.
2. Turn unit ON, allow to warm-up before proceeding.
3. Place buns on the conveyor, cut side up.
4. Toasted buns will drop down the toaster chute.
5. Turn the "Height Adjustment Knobs" to lower the platen for darker buns, raise for lighter buns.

**CERTAIN SURFACES ARE EXTREMELY HOT DURING OPERATION AND CARE SHOULD BE TAKEN WHILE USING THIS UNIT.**

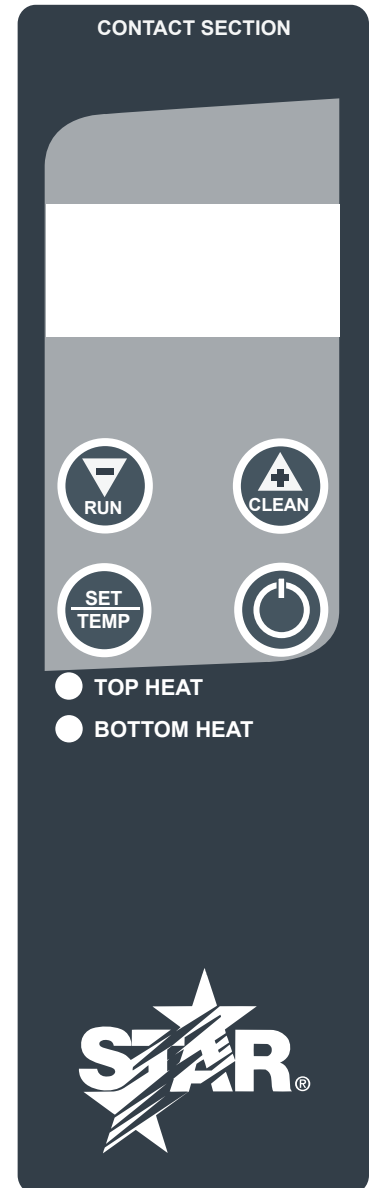

# RADIANT TOASTER DAILY OPERATION ELECTONIC CONTROL

## START UP

When the toaster has been plugged into a suitable outlet and power supply, the word OFF will be displayed on the L.E.D. read out.

- Press the ON/OFF button once to turn on the toaster. The toaster will now enter into pre-heat and PREHT will be displayed (the elements will begin to glow but the conveyor and fan motor will not turn on).
- After one minute, the fan motor will turn on and the conveyor will begin turning at the previously saved setting (for initial start up, the drive motor will operate at the factory default setting).
- After four minutes, the display will show the last used program selection i.e. TOAST, BAGEL, MUFFIN or OTHER (for initial startup, TOAST will be the last program selected).

## DAILY OPERATION

Check the power cord to insure that it is plugged into a proper outlet.

Press the ON/OFF button once to turn the toaster on.

Press the button a second time to turn the toaster off.

**NOTE:** When the toaster is turned off, the fan and conveyor motors will continue to run for five minutes. The words **COOL** and **DOWN** will be alternately displayed during that time. After five minutes, the word **OFF** will be displayed until the **ON/OFF** button is pressed again.

The radiant conveyor toaster comes with pre-programmed factory default settings (shown in chart below). The operator may change these setting at any time.

Press T1 and T1 will appear in the display and similar for the other buttons

## Power Saver Mode

The radiant toaster is equipped with a Power Saver Switch (SAVER) that reduces the power used by the toaster after a pre-programmed period of time. This Power Saver Switch has three modes:

- ON:** Unit is in pre-programmed power saving setting.
- OFF:** Power Saver mode is turned off.
- AUTO ON:** Power Saver turns on when there has been no activity for a programmed length of time.

The operator may adjust the level of power reduction for the saver mode. (Note: conveyor may move slowly when in saver mode.)

Two buttons (+) and (-) are used when increasing or decreasing the value of each programmable setting.

A red LED light located at the lower portion of the control panel label will indicate if the value for top heat, bottom heat or conveyor speed is being adjusted.

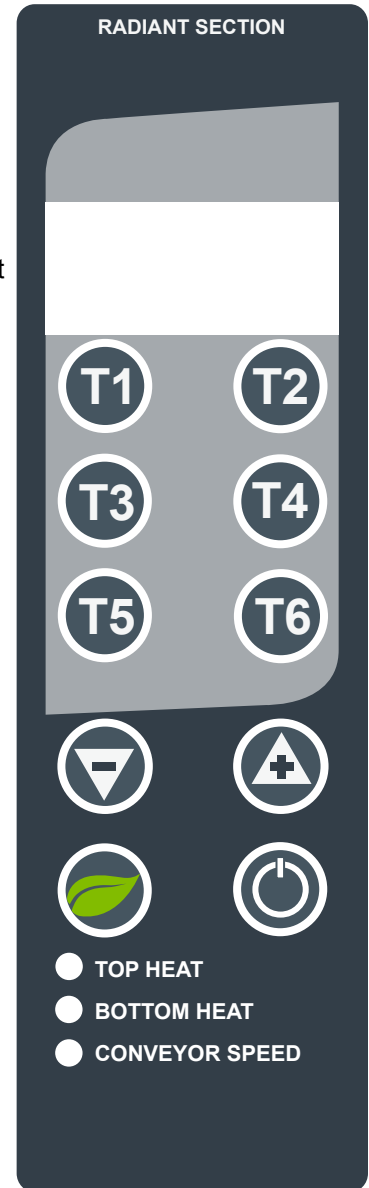

CRT14E Default Settings			
Radiant Heat			
Menu Buttons	Top Heat	Bottom Heat	Conveyor Speed
T1	10	10	90
T2			70
T3			50
T4			30
T5			20
T6			10

2M-Z20664; Contact & Radiant Dual Toaster

## DAILY OPERATION

Check the power cord to insure that it is plugged into a proper outlet.

Set the heat control knobs to desired temperature.

Always allow a minimum 10 minutes of preheat time before loading the unit with product.

Failure to allow sufficient preheat time will result in unsatisfactory cooking until the unit reaches operating temperature.

## TOASTER COMPONENTS

The CRT14E is equipped with controls on both the left and right side of the unit. The Left side controls the top contact toaster conveyor and the right side controls the lower radiant conveyor.

## HIGH LIMIT RESET

Your unit is equipped with a temperature activated heat limit switch that will interrupt the power to the heater tubes if the temperature inside the control box exceeds 190° F (88°C). The HIGH LIMIT/RESET can be manually reset by pushing the button located at the rear of the control box, see Features & Benefits on page 4 for location.



**CAUTION**

**CERTAIN SURFACES ARE EXTREMELY HOT DURING OPERATION AND CARE SHOULD BE TAKEN WHILE USING THIS UNIT.**

## OPERATING HINTS & SAFETY

Disconnect power to the unit by pressing the powerswitch at the end of each day of operation.

Do not leave the unit in operation without an attendant.

Put unit into Powersaver mode during idle periods. It will take only a few minutes to regain operating temperature.

Do not leave the unit at high temperature when not in use or during idle periods.

This will cause food particle and grease film to carbonize.

Product (bread) with excessive moisture or frozen will toast differently than day old bread which has less moisture.

Never operate the unit without crumb trays in place at this causes overheating in the control box.

Never spray conveyor belt or toasting chamber with a non-stick spray.

## CLEANING

Preventive maintenance for your toaster consists of the following recommended cleaning procedures. To keep your toaster in its top operating condition, these steps should be performed on a daily or weekly as indicated.

1. Clean air intake on bottom of unit.
2. For lightly soiled conveyor belts, turn conveyor speed control to fastest setting (100) and wipe with a damp cloth (daily) For heavily soiled conveyors, turn conveyor speed control to fastest setting and wipe with a light abrasive pad (as needed).
3. Turn main power saver switch to the OFF position. Disconnect unit from power source.
4. Remove non-stick sheet and clean with mild detergent and damp cloth. (If excess buildup is unable to be removed and causing buns to stick to the sheet, a new sheet may need to be installed.)
5. Remove crumb tray and toast slide and wash in a sink with mild detergent.
6. Dry and return crumb tray, toast slide, and non-stick sheet back into position.
7. Turn the power switch to the "OFF" position, until you need



**WARNING**

**DO NOT IMMERSE OR LET THE UNIT STAND IN WATER.**

**DO NOT HOSE DOWN THE UNIT OR THE TABLE/COUNTER IF THE UNIT IS ON THE TABLE/COUNTER.**

**KEEP AWAY FROM RUNNING WATER.**

## Contact Clam Platen Cleaning Procedures

1. Press and hold the clean button for 3 seconds to enter the clean mode.
2. Display will flash "CLEAN WAIT" until platen reaches 275°F and conveyor will stop.
3. Wait for display to show "CLEAN READY", approx. 15 minutes.
4. Raise platen and secure with bracket.
5. Remove the non-stick sheet.
6. Place a quarter pan or rags on the top conveyor to catch the drippings.
7. Attach a cleaning pad to holder
8. Pour some Heat-Activated Grill and Toaster Cleaner (1oz) onto cleaning pad.  
**NEVER POUR DIRECTLY ONTO PLATEN.**



**Wear heat resistant gloves to clean unit.**

9. Scrub both the HEEL & CROWN sides the platen surface, applying more solution between sides.
10. Using warm water, mild detergent, and a clean cloth on the platen to remove the Heat-Activated Cleaner. Rinse cloth with clean water to remove any Heat-Activated Solution Cleaner before dipping it back into the warm soap solution.
11. Take unit out of Clean Mode so the conveyor will begin to turn, wipe down the belt and exterior of the unit.
12. Remove crumb trays and toast slide and non-stick sheet with soap and water.
13. Dry and return all pieces to their original positions.
14. Running unit without a non-stick sheet will damage the unit, be sure to install non-stick sheet.
15. Close platen

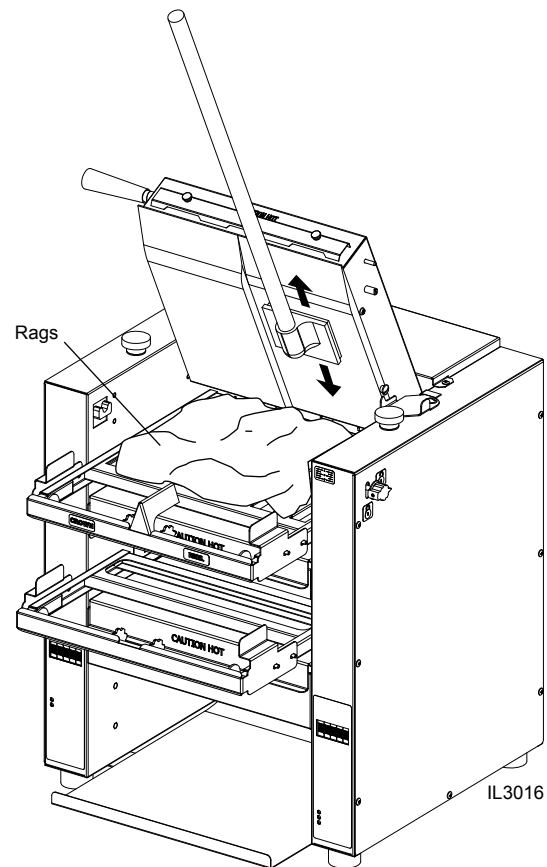
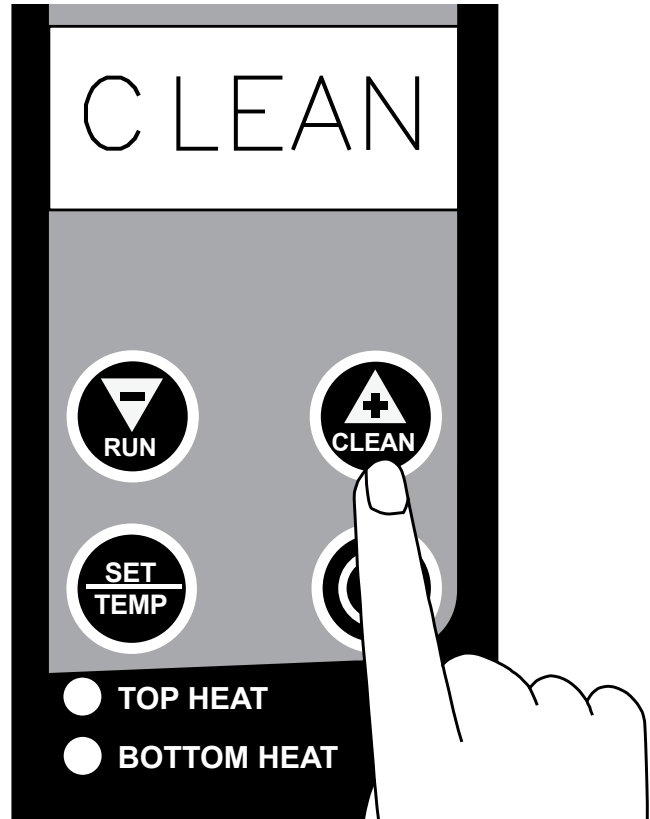

2M-Z20664; Contact & Radiant Dual Toaster

IL3016

# MAINTENANCE PROCEDURES

## A. REPLACING RADIANT HEATER TUBES

- 1) DISCONNECT UNIT FROM POWER SOURCE.
- 2) Remove the side panels.
- 3) Remove heater tube wire from terminal block connection, keeping top and bottom wires separate.
- 4) Lift heater tube retainers by loosening retaining screws and sliding the retainer plate up. Hand tighten the plate to hold it up so the heater tubes will slide out freely.
- 5) Gently, pull defective heater tube out of unit.
- 6) Gently, put new heater tube into unit and connect wires into the terminal block.
- 7) Loosen retainer screws and slide the retainer back into place. Tighten the screw to secure the retainer in place over the ends of the heater tubes.
- 8) Reinstall side panels.

## B. REPLACING FAN MOTOR

- 1) **DISCONNECT UNIT FROM POWER SOURCE.**
- 2) Remove screw from the air intake panel, located below the control box. Remove & wipe clean.
- 3) Remove the screws on the control box cover and remove cover.
- 4) Unplug power supply cord from fan motor.
- 5) Remove (4) screws, which hold fan motor and grill to the control box cover and remove fan.
- 6) Put replacement motor and grill in place and secure to the cover with screws.
- 7) Wipe the control box with a damp cloth, using mild detergent.
- 8) Reconnect power supply cord to fan motor.
- 9) Replace the control box cover & air intake panel. Fasten with screws removed in step 2 & 3.

## C. REPLACING BELT DRIVE MOTOR

- 1) DISCONNECT UNIT FROM POWER SOURCE.
- 2) Remove screw from the air intake panel, located below the control box. Remove & wipe clean.
- 3) Remove the screws on the control box cover and remove cover.
- 4) Remove the screws on the side panel and remove panel.
- 5) Remove sprocket from motor shaft, using an Allen wrench and loosening the set-screw.
- 6) Remove the wire from terminal block connecting the drive motor to internal wiring.  
On units rated 208 or 240 volts, note which color leads are being used for these connections and which lead is capped with white tape. The new motor should use the same arrangement.
- 7) Remove screws holding motor in place and remove motor from unit.
- 8) Put new motor in place and attach loosely with mounting screws.
- 9) Replace sprocket on motor shaft.

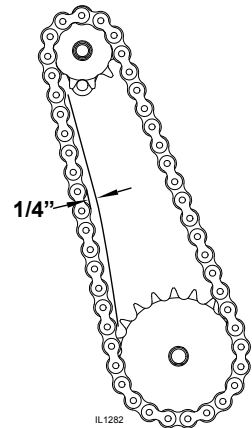

**NOTE: The two sprockets should line up parallel with each other, so the chain does not twist any during operation. Also the hub gets installed closest to the motor.**

- 10) Slide motor until the drive chain has about 1/4" slack when lightly pushed at the center of its top open run. See chain tensioning illustration.
- 11) Tighten screws to secure motor.
- 12) Rewire leads same as removed in step 4.
- 13) Replace side panel, control box cover & air intake panel.

## MAINTENANCE PROCEDURES con't

### D. CLEANING AIR INTAKE ONCE A WEEK

- 1) **DISCONNECT UNIT FROM POWER SOURCE.**
- 2) Remove screw from the air intake panel. Remove & wipe clean
- 3) Use a vacuum cleaner and or a damp cloth to clean the air intake.  
This procedure should be done at least every week.

### E. LUBRICATE THE CHAIN & SPROCKETS EVERY 6 MONTHS

- 1) **DISCONNECT UNIT FROM POWER SOURCE.**
- 2) Remove side panels exposing chain drive.
- 3) Using an extreme pressure, synthetic chain lubricant with a temperature range up to 400°F. Apply liberally onto chain and sprockets. This grease is available as part no. 1L-Z12397.
- 4) Replace enclosure, Reconnect power source and test unit.

## REMOVING & REPLACING SILICONE BELT

1. Disconnect unit from power allow to cool before beginning process.
2. Remove guard from in front of the belt.
3. Rotate belt by hand until belt seam is visible.
4. The Idler Shaft is spring loaded. Press on the front idler shaft to remove tension from the belt. (Continuous pressure is required).
5. Pull splicing rod from belt.
6. Carefully release pressure from idler shaft so the roller is not propelled from the unit by the springs.
7. Installation is similar to removal. Feed the belt around the drive shaft and idler shaft rollers making sure the tracking guide on the backside of the belt is seated in the roller grooves.
8. Press the front roller to create slack in the belt.
9. Feed the splicing rod through the two ends of the belt.
10. Remove pressure from roller and install belt guard.
11. Plug unit back into outlet and test for proper operation.

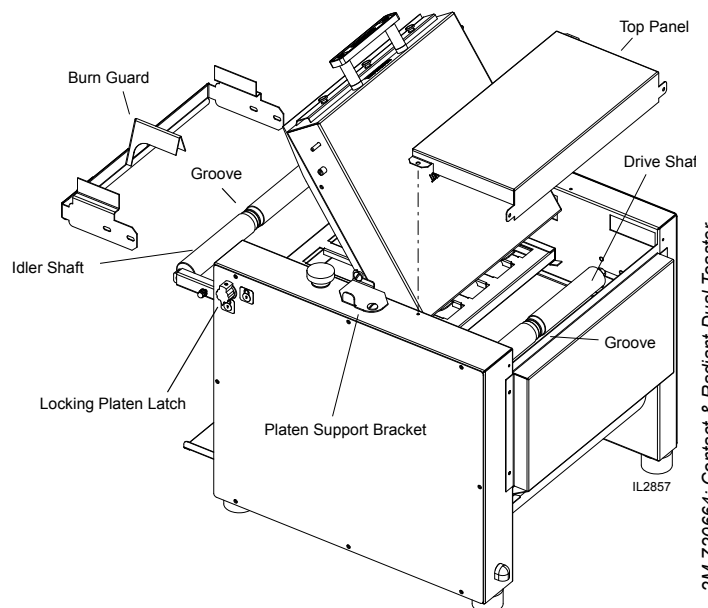

**DISCONNECT THE POWER SUPPLY BEFORE SERVICING OR CLEANING THIS OVEN. SAFEGUARD THE POWER SO IT CANNOT BE ACCIDENTALLY RESTORED. FAILURE TO DO SO COULD RESULT IN DISMEMBERMENT, ELECTROCUTION, OR FATAL INJURY.**

Visit our Website at: [www.star-mfg.com](http://www.star-mfg.com)

Email: [customerservice@star-mfg.com](mailto:customerservice@star-mfg.com)

### THOROUGHLY INSPECT YOUR UNIT ON ARRIVAL

This unit has been tested for proper operation before leaving our plant to insure delivery of your unit in perfect condition. However, there are instances in which the unit may be damaged in transit. In the event you discover any type of damage to your product upon receipt, you must immediately contact the transportation company who delivered the item to you and initiate your claim with same. If this procedure is not followed, it may affect the warranty status of the unit.

### LIMITED EQUIPMENT WARRANTY

All workmanship and material in Star products have a one (1) year limited warranty on parts & labor in the United States and Canada. Such warranty is limited to the original purchaser only and shall be effective from the date the equipment is placed in service. Star's obligation under this warranty is limited to the repair of defects without charge, by the factory authorized service agency or one of its sub-agencies. Models that are considered portable (*see below*) should be taken to the closest Star service agency, transportation prepaid.

- > Star will not assume any responsibility for loss of revenue.
- > On all shipments outside the United States and Canada, see International Warranty.
- \* The warranty period for the Ultra-Max, Hot Plates, Griddles, Charbroilers is (3) years parts & labor.
- \* The warranty period for the Star-Max, Charbroilers, Griddles, Hot Plates, Fryers & Finishing Oven is (2) years parts & labor.
- \* The warranty period for the JetStar six (6) ounce & Super JetStar eight (8) ounce series popcorn machines is two (2) years.
- \* The warranty period for the Chrome-Max Griddles is five (5) years on the griddle surface. See detailed warranty provided with unit.
- \* The warranty period for Dura-Tec coatings is one year under normal use and reasonable care. This warranty does not apply if damage occurs to Dura-Tec coatings from improper cleaning, maintenance, use of metallic utensils, or abrasive cleaners, abrasive pads, product identifiers and point-of-sale attachments, or any other non-food object that comes in continuous contact with the roller coating. This warranty does not apply to the "non-stick" properties of such materials.
- > This warranty does not apply to "Special Products" but to regular catalog items only. Star's warranty on "Special Products" is six (6) months on parts and ninety (90) days on labor.
- > This warranty does not apply to any item that is disassembled or tampered with for any purpose other than repair by a Star Authorized Service Center or the Service Center's sub-agency.
- > This warranty does not apply if damage occurs from improper installation, misuse, wrong voltage, wrong gas or operated contrary to the Installation and Operating instructions.
- > This warranty is not valid on Conveyor Ovens *unless* a "start-up/check-out" has been performed by a Factory Authorized Technician.

### PARTS WARRANTY

Parts that are sold to repair out of warranty equipment are warranted for ninety (90) days. The part only is warranted, the labor to replace the part is **NOT** warranted.

### SERVICES NOT COVERED BY WARRANTY

1. Travel time and mileage rendered beyond the 50 mile radius limit
2. Mileage and travel time on portable equipment (*see below*)
3. Labor to replace such items that can be replaced easily during a daily cleaning routine, ie; removable kettles on fryers, knobs, grease drawers on griddles, etc.
4. Installation of equipment
5. Damages due to improper installation
6. Damages from abuse or misuse
7. Operated contrary to the Operating and Installation Instructions
8. Cleaning of equipment
9. Seasoning of griddle plates
10. Voltage conversions
11. Gas conversions
12. Pilot light adjustment
13. Miscellaneous adjustments
14. Thermostat calibration and by-pass adjustment
15. Resetting of circuit breakers or safety controls or reset buttons
16. Replacement of bulbs
17. Replacement of fuses
18. Repair of damage created during transit, delivery, & installation OR created by acts of God

### PORTABLE EQUIPMENT

Star will not honor service bills that include travel time and mileage charges for servicing any products considered "Portable" including items listed below. These products should be taken to the Service Agency for repair:

- \* The Model 510FD, 510FF Fryer.
- \* The Model 526TOA Toaster Oven.
- \* The Model J4R, 4 oz. Popcorn Machine.
- \* The Model 518CMA & 526CMA Cheese Melter.
- \* The Model 12MC & 15MC & 18MCP Hot Food Merchandisers.
- \* The Model 12NCPW & 15NCPW Nacho Chip/Popcorn Warmer.
- \* All Hot Dog Equipment **except Roller Grills & Drawer Bun Warmers.**
- \* All Nacho Cheese Warmers **except Model 11WLA Series Nacho Cheese Warmer.**
- \* All Condiment Dispensers **except the Model HPD & SPD Series Dispenser.**
- \* All Specialty Food Warmers **except Model 130R, 11RW Series, and 11WSA Series.**
- \* All QCS/RCS Series Toasters **except Model QCS3 & RCS3 Series.**
- \* All Fast Steamer Models **except Direct Connect Series.**

### ALL:

- \* Pop-Up Toasters
- \* Butter Dispensers
- \* Pretzel Merchandisers  
(Model 16PD-A Only)
- \* Pastry Display Cabinets
- \* Nacho Chip Merchandisers
- \* Accessories of any kind
- \* Sneeze Guards
- \* Pizza Ovens  
(Model PO12 Only)
- \* Heat Lamps
- \* Pumps-Manual

The foregoing warranty is in lieu of any and all other warranties expressed or implied and constitutes the entire warranty.

### FOR ASSISTANCE

Should you need any assistance regarding the Operation or Maintenance of any Star equipment; write, phone, fax or email our Service Department. In all correspondence mention the Model number and the Serial number of your unit, and the voltage or type of gas you are using.

 <b>STAR MANUFACTURING INTERNATIONAL INC.</b> #10 SUNNEN DRIVE, ST. LOUIS, MO. 63143, USA		MATERIAL -		MODEL NO. <b>CRT14</b>		PART NO. <b>SK-2906</b>	
DR. MRC	CK. MH	DATE	4/17/15	FINISH		TITLE	
				-		<b>WIRING DIAGRAM-2 TOP, 2 BOTTOM</b>	
				REVISIONS	LTR	DATE	DESCRIPTION OF CHANGE
							DR
TOLERANCES UNLESS OTHERWISE NOTED FRACTIONS ±1/64 DECIMALS ±.015 ANGLES ±1°				THIS DRAWING CONTAINS INFORMATION CONFIDENTIAL TO STAR MFG. INT'L. INC. NO REPRODUCTION OR DISCLOSURE OF ITS CONTENTS IS PERMITTED.			

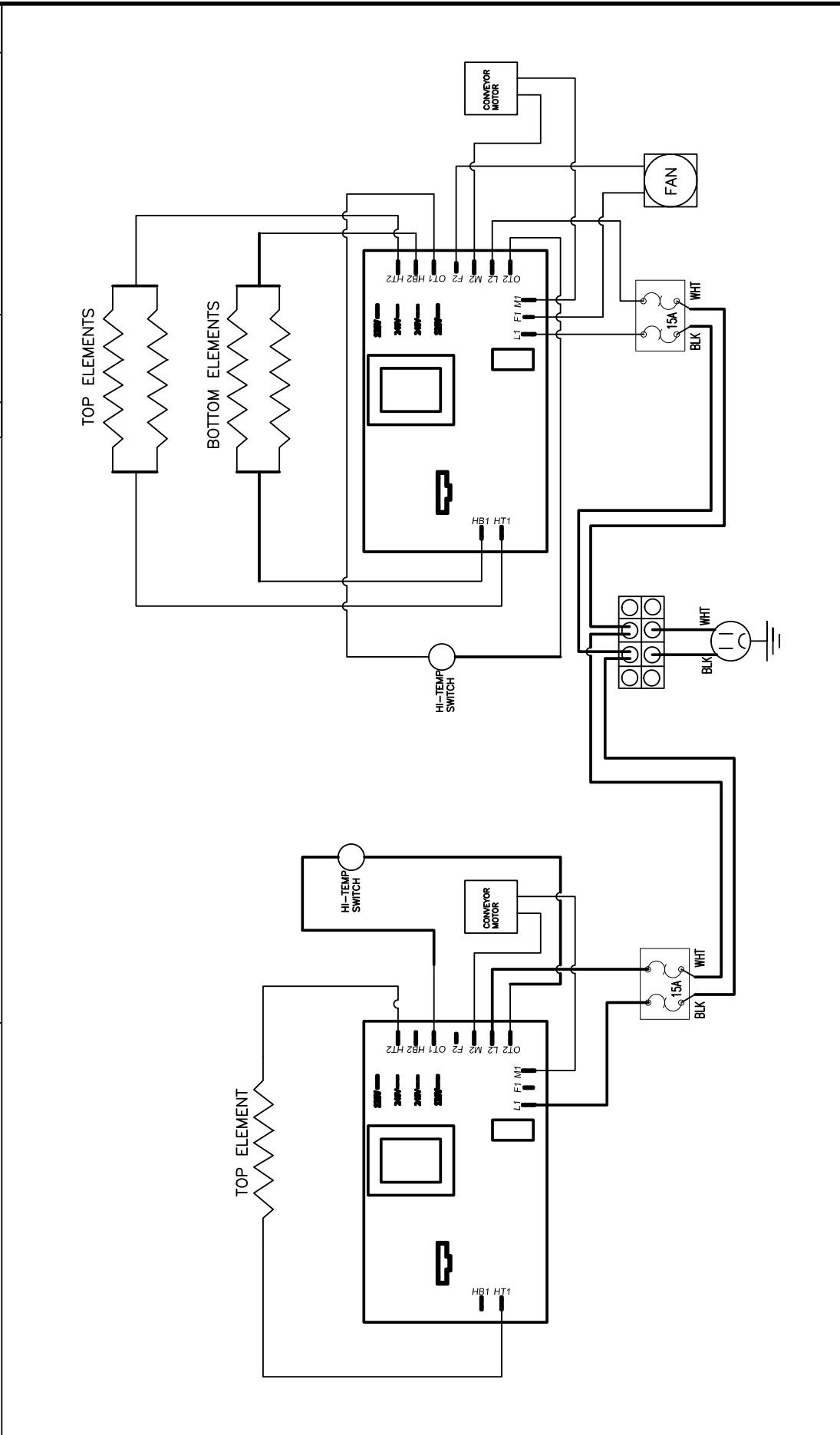



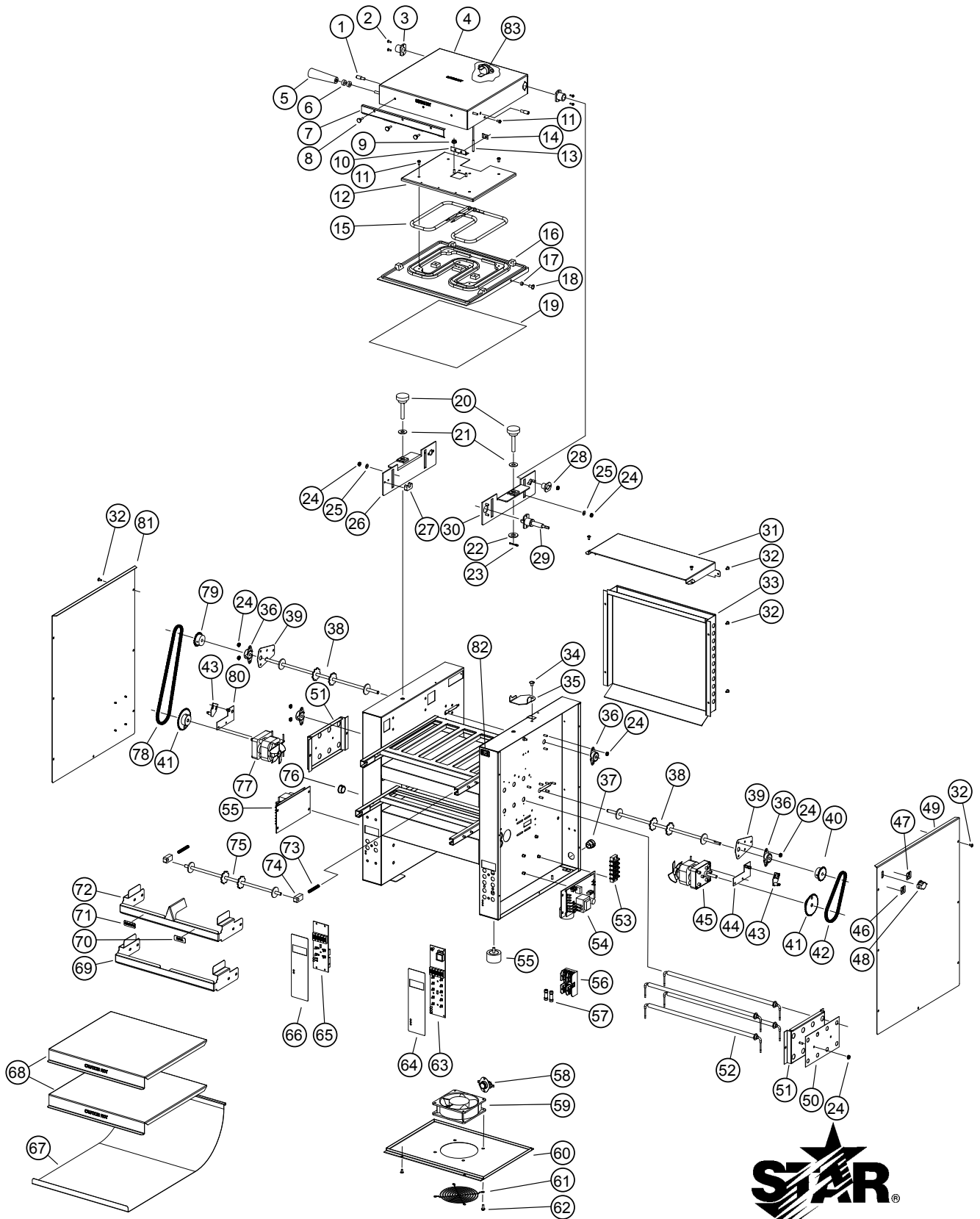

MODEL: CRT14E CONTACT / RADIANT TOASTER

SK2913, Rev. A, 7/30/2015

2M-Z20664; Contact & Radiant Dual Toaster



# PARTS LIST

October 19, 2015, Rev. B

Model: CRT14EM & CRT14ES Contact / Radiant Toaster				
Fig No.	Part Number	Quantity	Description	Application
1	2A-Z20478	2	SUPPORT-HOUSING 1.125"L	
2	2C-1488	12	SCREW 6-32X3/8 RHP STL NP	
3	2A-Z20477	2	BUSHING, OUTER	
4	HC-CT0043	1	PLATEN COVER ASSEMBLY	
5	2R-Y6762	1	HANDLE-DIMCO GRAY 190	
6	2A-Z17727	2	SPACER, 5/8"OD X 0.266"ID	
7	HC-Z17713	1	RETAINER, PTFE SHEET	
8	2A-Z17712	3	THUMBSCREW 8-32 X .375	
9	2C-6517	3	NUT 1/4-20 HEX STL NP	
10	HC-Z17724	1	THERMOPROBE BRKT	
11	2C-1512	11	SCREW 10-24X3/8 RHP STL	
12	HC-Z17711	1	ELEMENT COVER	
13	2E-Z17719	1	TYPE K PROBE	
14	2C-Z3350	1	HALF CLAMP .188 D STL ZP	
15	2N-Z17710	1	ELEMENT, METAL 2300W 240V	
16	2F-Z17708	1	13" TOP CASTING	
17	2A-Z18504	1	SPACER, 3/8IN X 1/4IN	
18	2C-Y7595	1	BOLT 1/4-20X1/2 THS STL	
19	2H-Z18588	1	PTFE SHEET 0.003 TK SING	
20	2A-CT0011	2	ADJUSTMENT KNOB ASY	
21	2H-Z17747	2	WASHER, 3/8IN OD TPTFE	
22	2C-20201-04	2	WSHR FLT 3/8 USS PLTD	
23	2C-Z19112	2	COTTER PIN, 7/64 X 3/4	
24	2C-Z6929	46	10-24 KEPS NUT S.S.	
25	2C-1810	24	WASHER 3/16 BURR STL NP	
26	HC-CT0012	1	LEFT ADJUSTMENT BRKT ASY	
27	2V-Z17744	1	PLATEN SUPPORT	
28	2K-Z17715	2	BUSHING, INNER	
29	HC-CT0014	1	PLATEN LATCH ASY	
30	HC-CT0013	1	RIGHT ADJUSTMENT BRKT ASY	
31	HC-Z20565	1	COVER, REAR	
32	2C-6349	22	SCREW #8X3/8 B THP STL NP	
33	HC-CT0039	1	REAR PANEL ASSEMBLY	
34	2C-Z10075	1	SCREW-1/4-20X3/8 SS THS	
35	HC-Z17737	1	PLATEN SUPPORT BRKT	
36	HA-112261	4	BEARING ASSY, 5/16 PTFE	
37	2K-Y6764	1	BUSHING - STRAIN RELIEF	
38	2A-202902	2	SHAFT, T714 DRIVE	CRT14EM
	2A-Z20476	1	BELT DRIVE SHAFT ASSY	CRT14ES
39	HC-Z16924	2	SHAFT ACCESS COVER PLATE	
40	2P-200645	1	SPROCKET, 25B17 X 5/16	
41	2P-200648	2	SPROCKET, 25B32 X 5/16	

2M-Z20664; Contact & Radiant Dual Toaster

# PARTS LIST

October 19, 2015, Rev. B

Model: CRT14EM & CRT14ES Contact / Radiant Toaster				
Fig No.	Part Number	Quantity	Description	Application
42	2P-Z20710	1	CHAIN #25 15" 60 LINKS	
43	2E-Z17514	2	SENSOR, SPEED	
44	HC-Z20563	1	BRACKET, SPEED SENSOR	
45	2U-Z9657	1	MOTOR,11RPM-CW,NEW STYLE	
46	2M-Z18512	1	LABEL, LOCK SYMBOL	
47	2M-Z18513	1	LABEL, UNLOCK SYMBOL	
48	2R-Z17729	1	KNOB, 1-1/4 X 5/8 X 1/2	
49	HC-Z20559	1	PANEL, RIGHT SIDE	
50	HC-Z20561	1	ELEMENT RETAINER	
51	HC-Z20564	2	ELEMENT SUPPORT	
52	2N-209130	4	ELEMENT, METAL 208V 800W	208V
	2N-209160		ELEMENT, METAL 240V 800W	240V
53	2E-Z10406	1	TERMINAL BLOCK 4 POS	
54	2U-200592	2	QCSE POWER BOARD	
55	2R-Z18201	4	FOOT 1.69X1 SIL 1/4 20	
56	2E-Z20554	2	FUSEHOLDER, 15A CLASS G	
57	2E-Z8405	4	FUSE,15A CLASS G	
58	2E-200566	1	SWTCH,RSET,0796-190F TRPS	
59	2U-200561	1	MOTOR, FAN 240V 23BTM	
60	HC-Z20560	1	MOTOR HOUSING COVER	
61	2R-200562	1	FAN GUARD FOR MUFFIN FAN	
62	2C-Z5883	4	10-24 X 1/2 FZA SCREW	
63	HC-Z20351	1	SOFTWARE, CRT14E	
64	2M-Z20369	1	LABELS, CRT14E	
65	2J-Z17717	1	ELECTRONIC CONTROL SPEC	
66	2M-Z20369	1	LABELS, CRT14E	
67	HC-Z20566	1	TOAST SLIDE	
68	HC-Z20569	2	CRUMB TRAY	
69	HC-Z20557	1	BELT GUARD	
70	2M-Z17735	1	LABEL, HEEL	
71	2M-Z17750	1	LABEL, CROWN	
72	HC-CT0040	1	BELT GUARD ASSEMBLY	
73	2P-Z18587	4	BEARING SPRING 2IN	
74	2P-200700	4	BRG SPRING LOADED	
75	2A-202905	2	SHAFT, 214HX IDLER	CRT14EM
		1		CRT14ES
	2A-202902	2	SHAFT, T714 DRIVE	CRT14ES
76	2K-200464	4	BUSHING, WIRE RING 7/8"	
77	2U-Z9658	1	MOTOR AC 11 RPM CCW	
78	2P-Z20735	1	CHAIN #25 26.5" 106 LINKS	
79	2P-200646	1	SPROCKET, 25B20 X 5/16	
80	HC-Z20562	1	BRACKET, SPEED SENSOR	

2M-Z20664; Contact & Radiant Dual Toaster

# PARTS LIST

October 19, 2015, Rev. B

Model: CRT14EM & CRT14ES Contact / Radiant Toaster				
Fig No.	Part Number	Quantity	Description	Application
81	HC-Z20558	1	PANEL, LEFT SIDE	
82	2M-Z18258	2	LABEL, SCALE	
83	2T-30401-30	1	STAT FXD 550 DEG OPEN	
NI	HM-160004	2	BELT, CONVEYOR 14" X 39", PLUS (3) LINKS	CRT14EM
		1		CRT14ES
NI	2B-200603	6	BELT LINK SPACECLIP	CRT14EM
		3		CRT14ES
NI	2E-200374	1	CORD SET 12/3 6-30 T714 8	
NI	2I-Z18519	1	SILICONE BELT SEGMENT 40"	CRT14ES

**STAR INTERNATIONAL HOLDINGS INC. COMPANY**

Star - Holman - Lang - Wells - Bloomfield - Toastmaster

10 Sunnen Drive, St. Louis, MO 63143 U.S.A.

(314) 678-6303

[www.star-mfg.com](http://www.star-mfg.com)