

**OPERATOR'S MANUAL
HOLMAN CONVEYOR TOASTERS
MODEL B910
FOR SERVICE INFORMATION
U.S. AND CANADA CALL: 1-800-225-3958
24 HOURS/DAY 7 DAYS/WEEK**

TABLE OF CONTENTS

UNCRATING AND INSPECTION	PAGE 1
ASSEMBLY AND INSTALLATION	PAGE 1, 2
POWER SAVER SWITCH	PAGE 2
COOKING PROCEDURES	PAGE 3, 4
CLEANING PROCEDURES	PAGE 4
TROUBLESHOOTING GUIDE	PAGE 5, 6
MAINTENANCE PROCEDURES	PAGE 7, 8, 9
PARTS LIST	PAGE 10

DRAWINGS

HEAT REFLECTOR/CRUMB TRAY	PAGE 1
LOAD AND UNLOAD TRAYS	PAGE 1
ADJ. HEAT SHIELD, FRONT VIEW	PAGE 3
COMPONENT ARRANGEMENT	PAGE 6 & 8
HEATER TUBE INSTALLATION	PAGE 7
DRIVE SYSTEM	PAGE 9
WIRING DIAGRAM	PAGE 11

REV. 1-31-96
MJC

FILE:FMICHAEL\MANUALS\B910VA

HG0153

**OPERATOR'S MANUAL
HOLMAN CONVEYOR TOASTERS
MODEL B910**

UNCRATING AND INSPECTION

Unpack unit and components from container. Remove all visible packing material, inspect unit for damage. If damage is discovered, file a claim immediately with the carrier that handled the shipment.

ASSEMBLY AND INSTALLATION

A. Attach legs by screwing into weld nuts, as shown below.

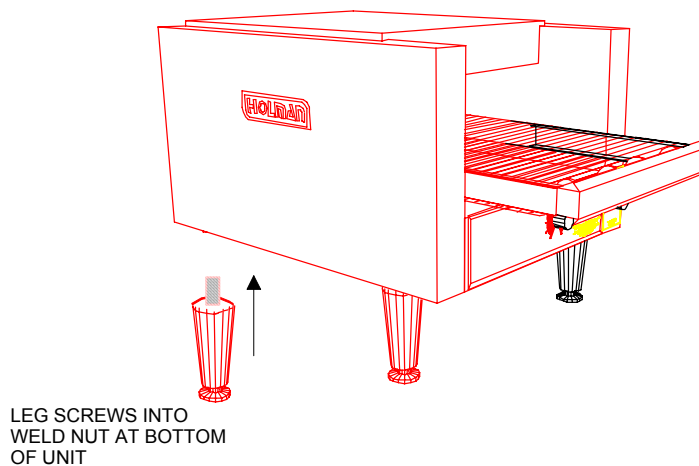

B910LEG.WMF

B. Anti Skid pads are available at no charge and may be adhered to the foot section of each leg to prevent sliding. Call 1-800-225-3958 for details.

WARNING: Use of these pads are not approved by the National Sanitation Foundation.

C. Place unload tray as shown below.

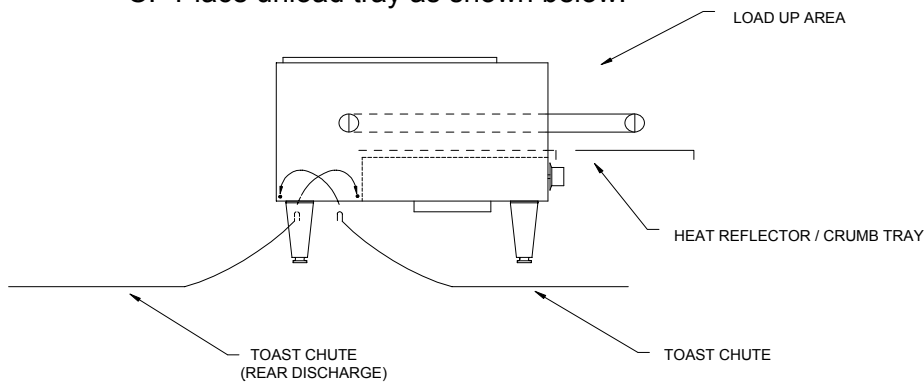

CAUTION: DO NOT OPERATE UNIT WITHOUT CRUMB TRAY PROPERLY POSITIONED AS THIS WILL CAUSE OVERHEATING IN THE CONTROL BOX.

Assembly and installation continued on page 2

REV. 1-30-96 MJC

**OPERATOR'S MANUAL
HOLMAN CONVEYOR TOASTERS
MODEL B910**

ASSEMBLY AND INSTALLATION CONT.

WARNING: MAKE SURE ALL INPUT POWER IS **OFF** BEFORE INSTALLING/REMOVING ANY PARTS.

WARNING: BEFORE INSTALLING UNIT(S), CHECK WITH LOCAL POWER COMPANY TO DETERMINE ACTUAL VOLTAGE AT JOB SITE. NEVER PLUG A 208 VOLT UNIT INTO 240 VOLTS OR A 240 VOLT UNIT INTO 208 VOLTS.

WARNING: BE ABSOLUTELY SURE THE GROUND CONNECTION FOR THE RECEPTACLE IS PROPERLY WIRED. NEVER CONNECT UNIT TO POWER WITHOUT PROPER GROUND CONNECTIONS. IMPROPER GROUND MAY RESULT IN SEVERE INJURY OR FATALITY.

POWER SAVER SWITCH

Your Holman toaster is equipped with a Power Saver Switch, details are as follows;

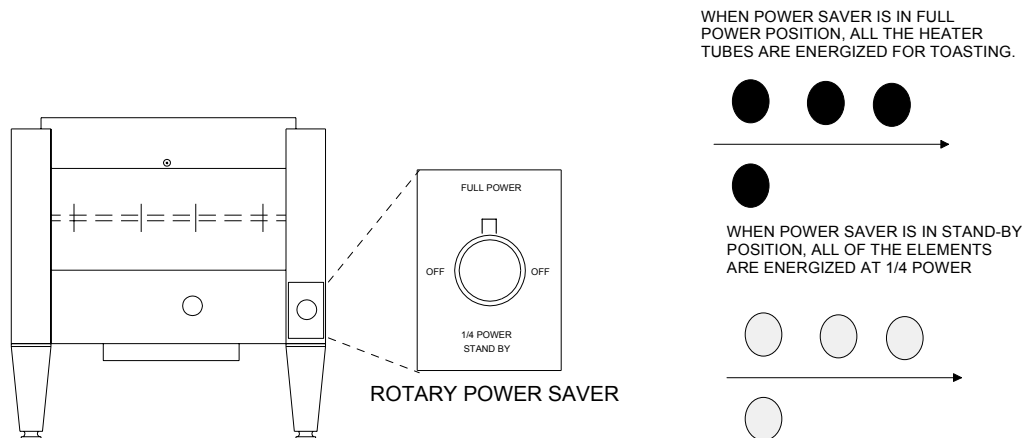

USING YOUR POWER SAVER SWITCH

Power Saver
Switch Positions

FULL POWER- When in this position your unit is at Full Power and ready to use. Conveyor Belt Speed Control to your desired settings.

OFF-ROTARY: Two off positions are provided so that a single rotation to either direction will result in the unit being turned OFF.

STANDBY- The standby position reduces the power to the unit to 1/4, and therefore saves 75% of the energy consumption. In this position your unit will stay warm and reduce the reheat time when switched to Full Power to 20 to 30 seconds.

**OPERATOR'S MANUAL
HOLMAN CONVEYOR TOASTERS
MODEL B910**

COOKING PROCEDURES

A. BAGEL TOASTING

1. On model B910 lower the Front Heat Shield all the way down, leave just enough clearance for bagel slices to pass under the shield into the cooking cavity (See illustration below).

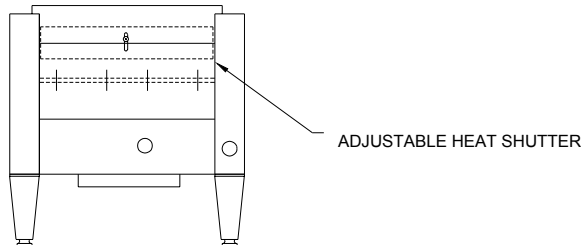

2. Turn power saver to the full power position. Three top elements and one lower element are now at full power. Turn Variable Speed Control to 50.
3. Allow warm up time of 5 to 10 minutes.
4. Test with a bagel half.
 - a. If bagel is too light, turn Variable Speed Control counterclockwise to a slower speed.
 - b. If bagel is too dark, turn Variable Speed Control clockwise to a faster speed.

B. BUN TOASTING

1. Turn power saver to the full power position. Turn Variable Speed Control to 50.
2. Lower the front heat shield as far as possible, leave just enough clearance for the bun half to pass under and into the cooking cavity. Refer to bagel toasting step 1 for adjustment instructions.
3. Test with a half of a bun.
 - a. If bun half is too light, turn Variable Speed Control counterclockwise to a slower speed.
 - b. If bun half is too dark, turn conveyor speed control clockwise to a faster speed.

Cooking procedures continued on page 4

**OPERATOR'S MANUAL
HOLMAN CONVEYOR TOASTERS
MODEL B910**

COOKING PROCEDURES CONT.

The model B910 has three tubes on the top and one on the bottom. Therefore when placing the bun or bagel halves on the conveyor you should place them cut side up.

CLEANING PROCEDURES

1. Turn Rotary Power Saver to the FULL POWER position.
2. For lightly soiled conveyor belts, turn Variable Speed Control to fastest setting (100) and wipe with a damp cloth.
3. For heavily soiled conveyors, turn Variable Speed Control to fastest setting (100) and wipe with a light abrasive pad.
4. Turn Rotary Power Saver to the OFF position.
5. After the unit cools, remove interior Crumb Tray (as shown below) and clean. Slide Crumb Tray back into position. **DO NOT OPERATE UNIT WITHOUT CRUMB TRAY IN PLACE AS THIS CAUSES OVERHEATING IN THE CONTROL BOX AND MAY ACTIVATE THE HEAT LIMIT SWITCH.**
6. Wipe exterior surface of unit.

LUBRICATION OF DRIVE CHAIN WITH A GRAPHITE BASED LUBRICANT IS REQUIRED AS PERIODIC MAINTENANCE. CALL HOLMAN FACTORY SERVICE DEPARTMENT FOR DETAILS.

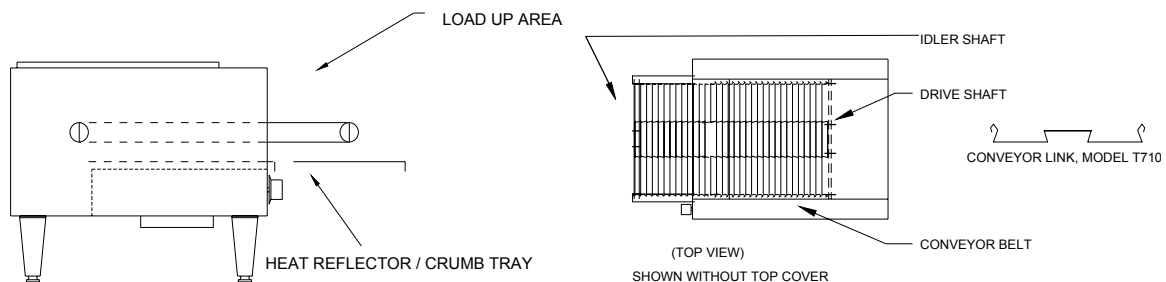

REV.12/23/96 MJC

**OPERATOR'S MANUAL
HOLMAN CONVEYOR TOASTERS
MODEL B910**

TROUBLESHOOTING GUIDE

A. UNIT WILL NOT HEAT, CONVEYOR WILL NOT TURN.

1. Be sure the main circuit breaker is switched to the ON position.
2. Check to see if the toaster is plugged in and all controls are turned to the ON position.

B. UNIT WILL NOT HEAT, CONVEYOR TURNS PROPERLY.

1. Check to see if Rotary Power Saver has been turned to the FULL POWER position.
2. Push Heat Limit Switch on rear of Control Box as shown below.
If this reactivates the Heater Tubes, see HEAT LIMIT SWITCH in section C.

C. HEAT LIMIT SWITCH

Your Holman conveyor toaster is equipped with an automatically activated Heat Limit Switch which interrupts the heater tube connections if the ambient temperature in the Control Box exceeds 190F (88C). This Heat Limit Switch can be reset manually by pushing the red button on the rear of the Control Box as shown below.

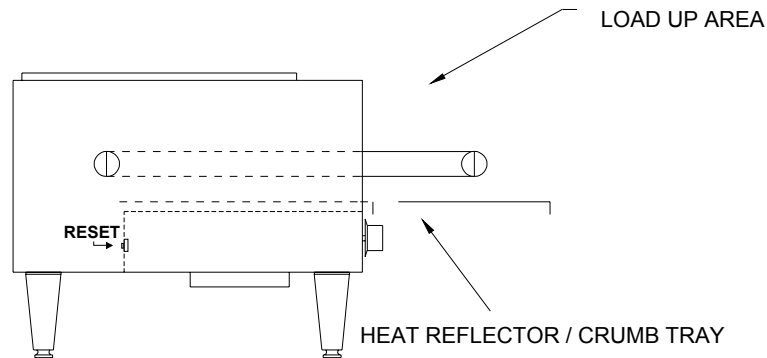

THE HEAT LIMIT SWITCH IS ACTIVATED WHEN THERE IS NOT SUFFICIENT AIR FLOW GENERATED BY THE COOLING FAN. WHEN HEAT LIMIT SWITCH HAS BEEN ACTIVATED:

1. DISCONNECT UNIT FROM POWER SOURCE.
2. Check to see if air intake area in the bottom center of the Control Box cover is free of dust, grease or other obstructions.

Troubleshooting guide continued on page 6

REV. 8/4/97 MJC

**OPERATOR'S MANUAL
HOLMAN CONVEYOR TOASTERS
MODEL B910**

TROUBLESHOOTING GUIDE CONT.

3. Check if Crumb Tray is in place. NEVER OPERATE UNIT WITHOUT CRUMB TRAY IN PLACE AS THIS CAUSES OVERHEATING IN THE CONTROL BOX.
4. If no obstructions to the air flow can be found and if the Crumb Tray is in place, call Holman Factory Service Department at **1-800-225-3958** for assistance.

D. CONVEYOR WILL NOT TURN, UNIT HEATS PROPERLY.

1. DISCONNECT UNIT FROM POWER SOURCE.
2. Remove right hand side panel (from operator's position). Loosen screws holding Drive Motor in place and slide motor toward the rear of unit. Remove Drive Chain and manually move conveyor belt to check for mechanical binding. If conveyor moves freely, call Holman Factory Service Department at **1-800-225-3958** as Drive Motor and/or Variable Speed Control may need replacement.

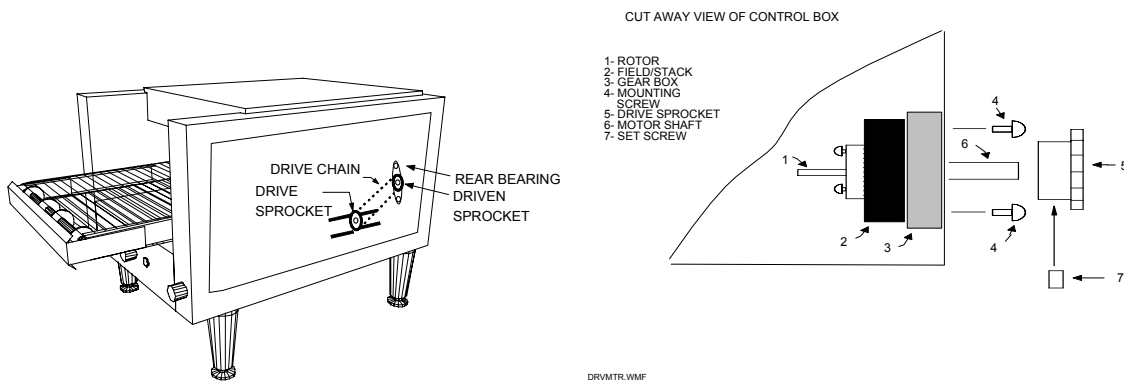

E. DRIVE MOTOR RUNS AT ONE SPEED REGARDLESS OF SPEED CONTROL SETTING.

1. Call Holman Factory Service Department at **1-800-225-3958** as Variable Speed Control should be replaced.

**OPERATOR'S MANUAL
HOLMAN CONVEYOR TOASTERS
MODEL B910**

MAINTENANCE PROCEDURES

- A. REPLACING HEATER TUBES (as below)
1. DISCONNECT UNIT FROM POWER SOURCE.
 2. Remove right and left side panels.
 3. Remove heater tube wire from terminal block connection, keeping top and bottom wires separate.
 4. Remove heater tube retainers by removing retaining screws with washer.
 5. Gently, pull defective Heater Tube out of unit.
 6. Gently, put new Heater Tube into unit.
 7. Replace Heater Tube Retainers, reconnect heater tube wires to terminal block and install side panels.

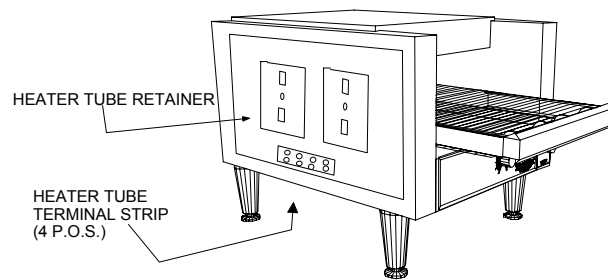

B910RET.WMF

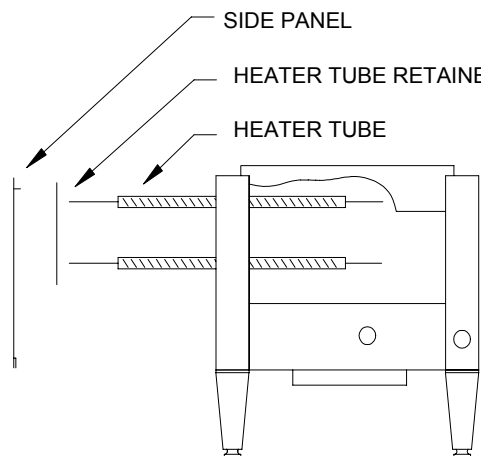

Maintenance procedures continued on page 8

REV. 1-30-96 MJC

**OPERATOR'S MANUAL
HOLMAN CONVEYOR TOASTERS
MODEL B910**

MAINTENANCE PROCEDURES (CONT.)

B. REPLACING FAN MOTOR

1. DISCONNECT UNIT FROM POWER SOURCE.
2. Remove Control Box Cover with Fan Motor attached.
3. Unplug power supply cord from Fan Motor.
4. Remove(4)screws which hold Fan Motor and grill to cover.
5. Put replacement motor and grill in place and secure to the Control Box Cover with screws.
6. Reconnect power supply cord to Fan Motor.
7. Replace Control Box Cover.

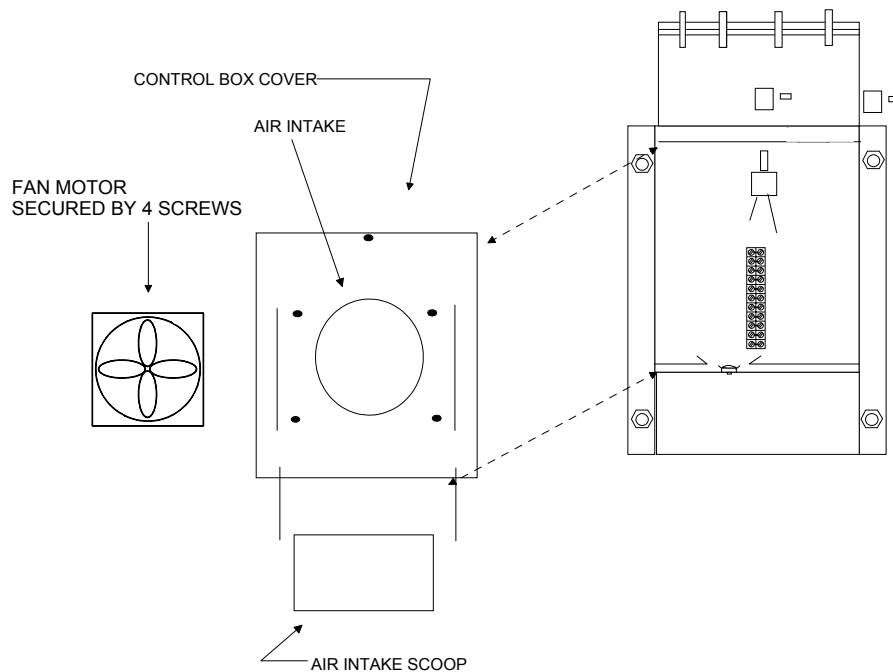

Maintenance procedures continued on page 9

REV. 8/4/97 MJC

**OPERATOR'S MANUAL
HOLMAN CONVEYOR TOASTERS
MODEL B910**

MAINTENANCE PROCEDURES (CONT.)

C. REPLACING BELT DRIVE MOTOR

1. DISCONNECT UNIT FROM POWER SOURCE.
2. Remove right side panels and Control Box Cover.
3. Remove sprocket from motor shaft.
4. Remove the wire from terminal block connecting the Drive Motor to internal wiring. On units rated 208 volts the white wire is used and on 240 volt units the blue wire is used. Note which color leads are being used for these connections and which lead is capped with white tape. The new motor should use the same arrangement.
5. Remove screws holding motor in place.
6. Put new motor in place and attach loosely with mounting screws.
7. Replace sprocket on motor shaft.
8. Slide motor until the Drive Chain has about 1/8" slack when lightly pushed at the center of its top open run.
9. Tighten screws to secure motor.
10. Rewire leads same as removed in step 4.
11. Replace side panel and Control Box Cover.

IF ASSISTANCE IS REQUIRED FOR THIS OR ANY OTHER PROCEDURE IN THIS MANUAL CALL HOLMAN FACTORY SERVICE DEPARTMENT AT **1-800-225-3958. 24 HOURS/DAY 7 DAYS/WEEK**

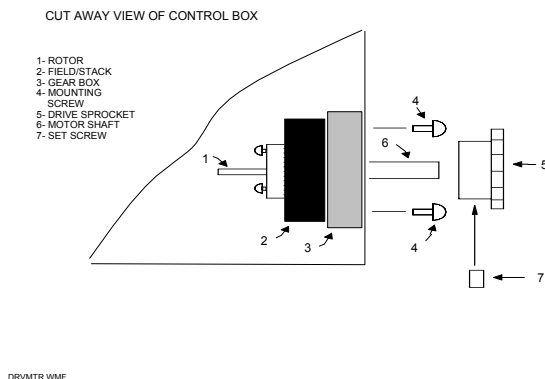
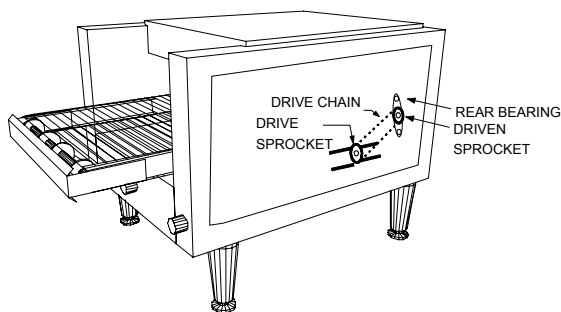

**OPERATOR'S MANUAL
HOLMAN CONVEYOR TOASTERS
MODEL B910**

WIRING DIAGRAM FOR MODEL B910 208/240 VOLTS 60 Hz

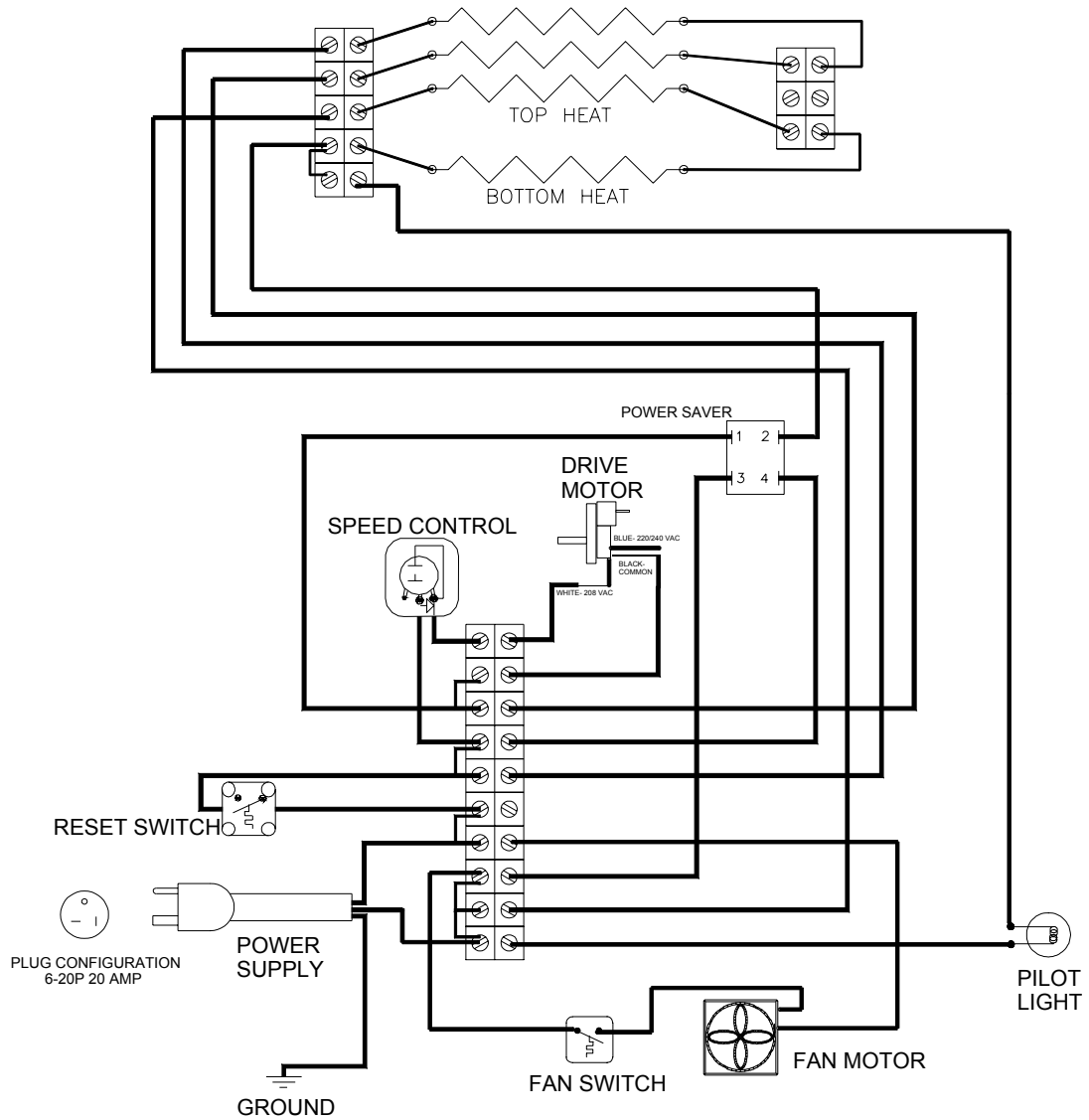

**OPERATOR'S MANUAL
HOLMAN CONVEYOR TOASTERS
MODEL B910**

PARTS LIST

<u>PART#</u>	<u>QTY</u>	<u>PAGE#</u>	<u>DESCRIPTION</u>
197841	4	7	Heater Tube, 208V
197842	4	7	Heater Tube, 240V
200566	1	5	Heat Limit Switch, 190F
160005	1	4	Conveyor Belt
400833	4	7	Heater Tube Retainers
150000	1	6	Drive Chain
100900	1	4	Drive Shaft
100904	1	4	Idler Shaft
112261	4	6	Bearing 5/16 I.D.
200509	1	9	Drive Motor 208-240V
200703	1	6	Knob, Control
200560	1	8	Fan Motor, 208/240V
118042	1	6	Speed Control 208-240
200562	1	Not Shown	Fan Grill
100528	1	4	Crumb Tray
200551	1	2	Power Saver Switch, Rotary
200387	1	13	Cord/Plug Set, (Fan Motor)
140038	1	13	Cord/Plug Set
200537	1	Not Shown	Fan Switch