



**Star  
Manufacturing  
International Inc.**

10 Sunnen Drive  
St. Louis, MO 63143

Phone: (314) 781-2777  
Fax: (314) 781-3636

**Installation  
and  
Operating  
Instructions**

2M-Z6395 Rev. -- 10/18/02

---

# **STAR-MAX PROPANE GAS GRIDDLE MODELS**

**8G-624MZ-LP, 8G-636MZ-LP, 8G-648MZ-LP  
8G-624TZ-LP, 8G-636TZ-LP, 8G-648TZ-LP**



## SPECIFICATIONS

---

### **8G-624MZ-LP**

Type: Manual Control

2 Controls, 40,000 BTU, 498 sq. in. (3213.4 sq cm) Grid Area, 3/4" (1.9 cm) Plate Thickness,  
Approximate Weight: Installed 165 lbs. (74.8 kg); Shipping 175 lbs. (79.4 kg)

Dimensions: 24"W x 27 3/4"D x 13 1/2"H  
(61 cm W x 70.5 cm D x 34.3 cm H)

---

### **8G-636MZ-LP**

Type: Manual Control

3 Controls, 60,000 BTU, 747 sq. in. (4819.6 sq cm) Grid Area, 3/4" (1.9 cm) Plate Thickness,  
Approximate Weight: Installed 247 lbs. (112 kg); Shipping 262 lbs. (118.8 kg)

Dimensions: 36"W x 27 3/4"D x 13 1/2"H  
(91.4 cm W x 70.5 cm D x 34.3 cm H)

---

### **8G-648MZ-LP**

Type: Manual Control

4 Controls, 80,000 BTU, 996 sq. in. (6426.2 sq cm) Grid Area, 3/4" (1.9 cm) Plate Thickness,  
Approximate Weight: Installed 330 lbs. (144.7 kg); Shipping 350 lbs. (158.8 kg)

Dimensions: 48"W x 27 3/4"D x 13 1/2"H  
(121.9 cm W x 70.5 cm D x 34.3 cm H)

---

### **8G-624TZ-LP**

Type: Thermostat Control

2 Controls, 40,000 BTU, 498 sq. in. (3213.4 sq cm) Grid Area, 3/4" (1.9 cm) Plate Thickness,  
Approximate Weight: Installed 165 lbs. (74.8 kg); Shipping 175 lbs. (79.4 kg)

Dimensions: 24"W x 27 3/4"D x 13 1/2"H  
(61 cm W x 70.5 cm D x 34.3 cm H)

---

### **8G-636TZ-LP**

Type: Thermostat Control

3 Controls, 60,000 BTU, 747 sq. in. (4819.6 sq cm) Grid Area, 3/4" (1.9 cm) Plate Thickness,  
Approximate Weight: Installed 247 lbs. (112 kg); Shipping 262 lbs. (118.8 kg)

Dimensions: 36"W x 27 3/4"D x 13 1/2"H  
(91.4 cm W x 70.5 cm D x 34.3 cm H)

---

### **8G-648TZ-LP**

Type: Thermostat Control

4 Controls, 80,000 BTU, 996 sq. in. (6426.2 sq cm) Grid Area, 3/4" (1.9 cm) Plate Thickness,  
Approximate Weight: Installed 330 lbs. (144.7 kg); Shipping 350 lbs. (158.8 kg)

Dimensions: 48"W x 27 3/4"D x 13 1/2"H  
(121.9 cm W x 70.5 cm D x 34.3 cm H)

---

Units operate on Propane Gas

## **SAFETY SYMBOL**



This symbol is intended to alert the user to the presence of important operating and maintenance instructions in the manual accompanying the appliance.

---

## **RETAIN THIS MANUAL FOR FUTURE REFERENCE**

### **NOTICE**

Using any part other than genuine Star factory supplied parts relieves the manufacturer of all liability.

### **NOTICE**

Star reserves the right to change specifications and product design without notice. Such revisions do not entitle the buyer to corresponding changes, improvements, additions or replacements for previously purchased equipment.

## **MAINTENANCE AND REPAIRS**

Contact your local authorized service agent for service or required maintenance. Refer to the authorized service center listing provided with the unit. The Star Service Help Desk (1-800-807-9054) is available during normal business hours to answer any questions that may arise. Please have your model number and serial number for faster service.

## GENERAL INSTALLATION DATA



### CAUTION

This equipment is designed and sold for commercial use only by personnel trained and experienced in its operation and is not sold for consumer use in and around the home nor for use directly by the general public in food service locations. For equipment to be used by the general public, please contact the factory.

The Star-Max™ model griddles are equipped for use with the types of gas specified on the nameplate.

### -IMPORTANT-

The installation of the Appliance should conform to the NATIONAL FUEL GAS CODE "ANSI Z223.1 - LATEST EDITION" AND ALL LOCAL GAS COMPANY RULES AND REGULATIONS.



### CAUTION

Improper installation, adjustment, alteration, service or maintenance can cause property damage, injury or death. Read the installation, operating and maintenance instructions thoroughly before installing or servicing the equipment.



### CAUTION

For your safety, do not store or use gasoline or other flammable vapors and liquids in the vicinity of this or any other appliance. Keep the appliance area clear and free from combustibles.

This appliance, its pressure regulator and its individual shutoff valve must be disconnected from the gas supply piping system during any pressure testing of that system at test pressures in excess of 1/2 PSIG (3.45KPA). This appliance and its pressure regulator must be isolated from the gas supply piping system by closing its individual manual shutoff valve during any pressure testing of the gas supply piping system at test pressures equal to or less than 1/2 PSIG (3.45KPA). **For your protection, we recommend a qualified installing agency install this appliance. They should be familiar with gas installations and your local gas requirements. In any case, your gas company should be called to approve the final installation. In addition, there should be posted, in a prominent location, detailed instructions to be followed in the event the operator smells gas. Obtain the instructions from the local gas supplier.**



### CAUTION

For your safety, if you smell gas:

1. Do not touch electrical switches.
2. Extinguish any open flame.
3. Immediately call your gas company.

### CLEARANCE

**For use on non-combustible countertops only.** Combustible and non-combustible material must be at least 48" (120cm) from the top of the appliance and 6" (150mm) from the sides and back. Adequate clearance should also be provided for proper operation and servicing.

### AIR SUPPLY

Make certain not to obstruct the flow of combustion and ventilation air. Make certain that air intake openings in the bottom of the appliance are not obstructed. They are essential for proper combustion and operation of the appliance.

## EXHAUST CANOPY

It is essential that facilities be provided over the griddle to carry off fumes and gases. However, the unit should not be directly connected to a flue or stack.

## LEVELING UNIT

This griddle is supplied with (4) feet which must be screwed into the legs attached to the body. Level unit by adjusting the (4) feet which have an adjustment of 1-3/4" (43.75mm) for accurate and perfect lineup with other units.



### CAUTION

**Do not install without attaching feet. Do not remove feet. Installation without feet will cause improper combustion and possible injury or death.**

## MANUAL SHUT OFF VALVE

A manual shut off valve should be installed upstream from the union and within 6 feet (1.829m) of this appliance.

## GAS PRESSURE REGULATOR

A pressure regulator is provided with each griddle. It should be connected to the inlet pipe at the rear of the unit. The gas supply line is then connected to it. The pressure regulator is shipped set for 10" water column manifold pressure for use with propane gas.



### CAUTION

**Gas pressure coming from the source must not exceed 1/2 PSIG, otherwise damage to the gas regulator and thermostat will occur.**

## GAS PIPING

Gas piping shall be of such size and so installed as to provide a supply of gas sufficient to meet the full gas input of the appliance. If the appliance is to be connected to existing piping, it shall be checked to determine if it has adequate capacity. Joint compound (pipe dope) shall be used sparingly and only on the male threads of the pipe joints. Such compounds shall be resistant to the action of LP gases. To connect to gas supply, attach pipe nipple provided with unit, attach pressure regulator to nipple, and gas supply to regulator. See Figure 1.

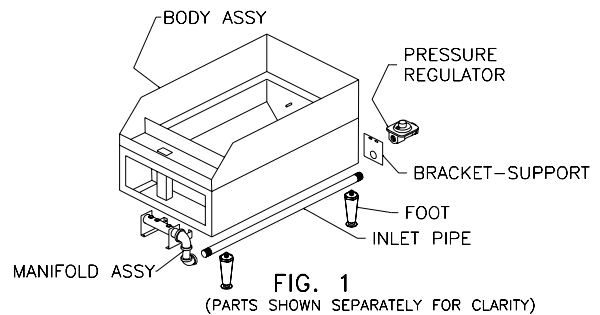

**WARNING:** Any loose dirt or metal particles which are allowed to enter the gas lines on this appliance will damage the valve and affect its operation. When installing this appliance, all pipe and fittings must be free from loose dirt.

## CHECKING FOR GAS LEAKS

Soap and water solution or other material acceptable for the purpose, shall be used in locating gas leakage. Matches, candle flame or other sources of ignition shall not be used for this purpose. Check entire piping system for leaks.

## PILOT LIGHT REGULATION

The pilot lights on this griddle have been turned off at the factory. Adjust pilot light flames as small as possible, but high enough to light burner immediately when burner valve is turned on high. See Figure 2.

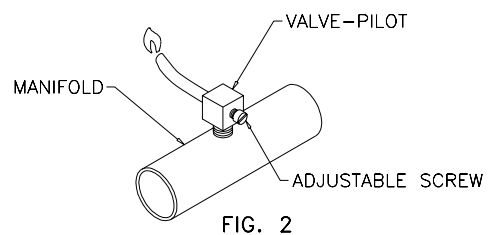

## BURNER OPERATION (MODELS 624MA, 636MA, and 648MA ONLY)

To ignite burners, turn burner valve knob to "HI" position. Each burner is controlled by an individual high-low, on-off valve. An infinite number of temperatures may be obtained by turning the burner valve knob to any position between high and low.

## BURNER ADJUSTMENT (MODELS 624MA, 636MA, and 648MA ONLY)

1. Turn burner valve knob to "HI" position.
2. Slowly decrease opening of air shutters to give a soft blue flame having luminous tips, then slowly increase openings to a point where the yellow tips disappear and a hard blue flame is obtained. See Figure 3.

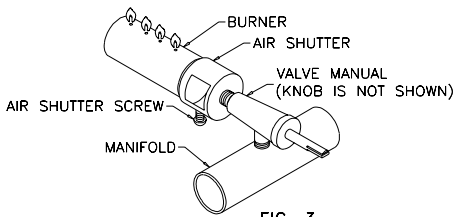

## BURNER ADJUSTMENT (MODELS 624TA, 636TA, 648TA, 624TB, 636TB, 648TB)

1. Push dial in and set thermostat of one burner to 450°F (229.9°C).
2. Observing flame through lighting hole, close the air shutter to give a soft blue flame having luminous tips then slowly increase opening to a point where the yellow tips disappear, and a hard blue flame is obtained. Repeat for all burners.

## LIGHTING INSTRUCTIONS

When griddle is first lit, it will smoke until the preservation oils and impurities are burned off.

1. Turn off main valve to unit and wait 5 minutes to clear gas.
2. Turn off all knobs and pilot valves and wait 5 minutes to clear gas.
3. Turn on main valve and light all pilots.
4. Turn burner knobs to desired setting.
5. To turn burners off, turn knobs off.

NOTE: The griddles are equipped with standing pilots and should be lit immediately after the gas is turned on.

## OVERNIGHT SHUTDOWN

Turn knobs to the off position to turn burners off.

## OPERATING INSTRUCTIONS

### SEASONING THE GRIDDLE HEATING SURFACE (NON-CHROMIUM SURFACES)

Clean the griddle surface thoroughly removing the preservation oil with a mild detergent and warm water. After the griddle has been thoroughly cleaned, it should be seasoned to prevent food from sticking. Before using, and after each thorough scouring, season the griddle heating surface in the following manner:

1. Turn the temperature control dial to 350°F (174.9°C).
2. Using a clean cloth, not a spatula, spread a thin film of cooking oil or fat over the griddle cooking surface. This film should remain on the hot griddle surface 1/2 hour.
3. Remove excess fat and wipe clean.
4. Apply another film of cooking oil over the hot cooking area for another 1/2 hour, and again remove excess fat and wipe clean. The griddle surface should now be ready for use.

Even with careful seasoning food may, to some extent, stick to the griddle cooking surface until griddle plate is "broken in."

## **COOKING (MODELS 624TA, 636TA, 648TA, 624TB, 636TB and 648TB ONLY)**

Set the thermostat dial knob to the temperature desired. After a preheating period of 30 minutes, the thermostat will automatically maintain the selected temperature within 50° of setting.

## **GRIDDLE CARE (NON-CHROMIUM SURFACES)**

It takes very little time and effort to keep the griddle attractive and performing at top efficiency. If grease is permitted to accumulate, it will form a gummy cake and then carbonize into a hard substance which is extremely difficult to remove. To prevent this condition, the following suggestions for cleanliness should be followed.

1. After each use, scrape the griddle with a scraper or flexible spatula to remove excess fat and food. A waste drawer is provided for the scrapings. If there is an accumulation of burned on fat and food, the griddle should be thoroughly scoured and reseasoned. Use pumice or griddle stone while the griddle is warm. Do not use steel wool because of the danger of steel slivers getting into the food.
2. Daily-use a clean cloth and good non-abrasive cleaner to clean the stainless steel body of the griddle. Wipe the polished front with a soft cloth.
3. At least once a day, remove the grease pan and wash in the same way as an ordinary cooking utensil. The drawer is removed by pulling forward, up and out.



## **CAUTION**

1. **Never** use Pumice, griddle stones, or abrasives on the surface of chrome top unit.
2. **Never** strike griddle surface with sharp instrument or spatula edge.
3. **Never** use steel wool.
4. **Never** use commercial liquid grill cleaner on the griddle surface.
5. **Abusing** surface voids the warranty.



## **CAUTION**

**EXERCISE EXTREME CARE IN HANDLING THE GREASE PAN CONTAINING HOT GREASE.**

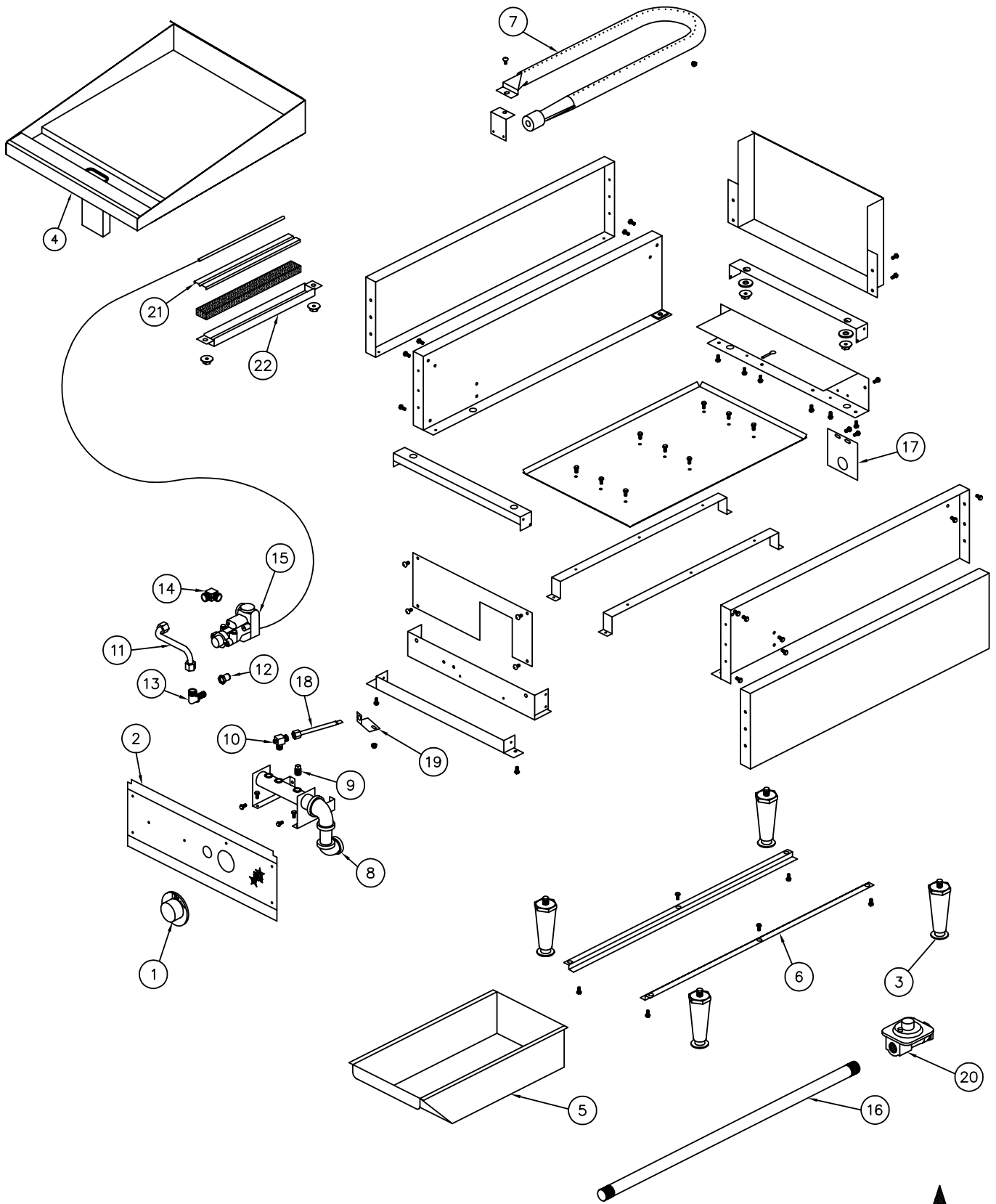

SOME ITEMS ARE INCLUDED FOR  
ILLUSTRATIVE PURPOSES ONLY AND IN  
CERTAIN INSTANCES MAY NOT BE AVAILABLE

This drawing contains information confidential  
to Star Manufacturing International, Inc.  
No reproduction or disclosure of its  
contents is permitted.



STAR MANUFACTURING INTERNATIONAL, INC.

# PARTS LIST

EFFECTIVE 10/18/02

8G-624TZ-LP STAR-MAX GAS GRIDDLE  
 MODEL 24" THERMOSTATIC CONTROL

Key Number	Part Number	Number Per Unit	Description
1	2R-ZI273	2	KNOB-CONTROL
2	G3-Z6338	1	FRONT PANEL
3	2A-Z0314	4	LEG
4	G3-GD0078 (624TZ)	1	GRIDDLE PLATE ASSEMBLY
5	G3-Y7046	1	GREASE DRAWER GRIDDLE
6	G3-Y7047	2	SLIDE DRAWER
7	G3-624008	2	BURNER ASSEMBLY
8	G3-624233 (624TZ)	1	MANIFOLD ASSEMBLY COMPLETE
	G3-GD0037 (624TZ)	1	MANIFOLD ASSEMBLY COMPLETE
9	2P-1453	1	PLUG-PIPE
10	2V-6671	2	VALVE-PILOT
11	G3-T1022	2	TUBE ORIFICE
12	2J-Y7250	2	ORIFICE #55 L.P.
13	2A-9369	2	ORIFICE-FITTING
14	2K-Y7111	2	FITTING COMPRESSION
15	2T-Z4293	2	THERMOSTAT
16	2K-Y7123	1	INLET PIPE
17	G3-Y7252	1	INLET PIPE SUPPORT
18	G3-Y7355	2	TUBE-PILOT
19	G3-Y7356	2	PILOT BRACKET
20	G3-Z3785	1	REGULATOR-PRESSURE
21	G3-Y7040 (624TZ)	1/2	TENSIONER
22	G3-Y7039 (624TZ)	1/2	BULB-CLAMP
	G3-Z4398 (624TZ)	1/2	BULB-CLAMP
	G3-GD0036 (624TZ)	2	TUBE-WASHER ASSY. (NOT SHOWN)

**IMPORTANT: WHEN ORDERING, SPECIFY VOLTAGE OR TYPE GAS DESIRED  
 INCLUDE MODEL AND SERIAL NUMBER**

PAGE 1  
 OF 2

Some items are included for illustrative purposes only and in certain instances may not be available.

# PARTS LIST

EFFECTIVE 10/18/02

8G-636TZ-LP & 8G-648TZ-LP STAR-MAX GAS GRIDDLE  
MODEL 36" AND 48" THERMOSTATIC CONTROL

Key Number	Part Number	Number Per Unit	Description
1	<a href="#">2R-Z1273</a> (636/648)	3/4	KNOB-CONTROL
2	<a href="#">G3-Z6340</a> (636)	1	FRONT PANEL
	<a href="#">G3-Z6342</a> (648)	1	FRONT PANEL
3	<a href="#">2A-Z0314</a>	4	LEG
4	<a href="#">G3-GD0081</a> (636TZ)	1	GRIDDLE PLATE ASSEMBLY
	<a href="#">G3-GD0084</a> (648TZ)	1	GRIDDLE PLATE ASSEMBLY
5	<a href="#">G3-Y7046</a>	1	GREASE DRAWER GRIDDLE
6	<a href="#">G3-Y7047</a>	2	SLIDE DRAWER
7	<a href="#">G3-624008</a> (636/648)	3/4	BURNER ASSEMBLY
8	<a href="#">G3-636228</a> (636TZ)	1	MANIFOLD ASSEMBLY COMPLETE
	<a href="#">G3-648218</a> (648TZ)	1	MANIFOLD ASSEMBLY COMPLETE
	<a href="#">G3-GD0039</a> (636TZ)	1	MANIFOLD ASSEMBLY COMPLETE
	<a href="#">G3-GD0040</a> (648TZ)	1	MANIFOLD ASSEMBLY COMPLETE
9	<a href="#">2P-1453</a>	1	PLUG-PIPE
10	<a href="#">2V-6671</a> (636/648)	3/4	VALVE-PILOT
11	<a href="#">G3-T1022</a> (636/648)	3/4	ORIFICE TUBE
12	<a href="#">2J-Y7250</a> (636/648)	3/4	ORIFICE #55 L.P.
13	<a href="#">2A-9369</a> (636/648)	3/4	ORIFICE FITTING
14	<a href="#">2K-Y7111</a> (636/648)	3/4	FITTING COMPRESSION
15	<a href="#">2T-Z4293</a> (636/648)	3/4	THERMOSTAT
16	<a href="#">2K-Y7123</a>	1	INLET PIPE
17	<a href="#">G3-Y7252</a>	1	INLET PIPE SUPPORT
18	<a href="#">G3-Y7355</a> (636/648)	3/4	TUBE-PILOT
19	<a href="#">G3-Y7356</a> (636/648)	3/4	PILOT BRACKET
20	<a href="#">G3-Z3785</a>	1	REGULATOR-PRESSURE
21	<a href="#">G3-Y7040</a> (636TZ/648TZ)	3/4	TENSIONER
22	<a href="#">G3-Y7039</a> (636TZ/648TZ)	3/4	BULB-CLAMP
	<a href="#">G3-Z4398</a> (636TZ/648TZ)	3/4	BULB-CLAMP
	<a href="#">G3-GD0036</a> (636TZ/648TZ)	3/4	TUBE-WASHER ASSY. (NOT SHOWN)

**IMPORTANT: WHEN ORDERING, SPECIFY VOLTAGE OR TYPE GAS DESIRED  
INCLUDE MODEL AND SERIAL NUMBER**

PAGE 2  
OF 2

Some items are included for illustrative purposes only and in certain instances may not be available.