



Star  
Manufacturing  
International Inc.

10 Sunnen Drive  
St. Louis, MO 63143

Phone: (314) 781-2777  
Fax: (314) 781-3636

Installation  
and  
Operating  
Instructions

2M-Z1436 Rev. C 1/8/03

# STAR-MAX ELECTRIC HOT PLATE

## MODELS 502Z and 502FZ



Model 502Z



Model 502FZ



## SAFETY SYMBOL



This symbol is intended to alert the user to the presence of important operating and maintenance instructions in the manual accompanying the appliance.

---

## RETAIN THIS MANUAL FOR FUTURE REFERENCE

### NOTICE

Using any part other than genuine Star factory supplied parts relieves the manufacturer of all liability.

### NOTICE

Star reserves the right to change specifications and product design without notice. Such revisions do not entitle the buyer to corresponding changes, improvements, additions or replacements for previously purchased equipment.

## MAINTENANCE AND REPAIRS

Contact your local authorized service agent for service or required maintenance. Refer to the authorized service center listing provided with the unit. The Star Service Help Desk (1-800-807-9054) is available during normal business hours to answer any questions that may arise. Please have your model number and serial number for faster service.

## GENERAL OPERATING INSTRUCTIONS



### CAUTION

This equipment is designed and sold for commercial use only by personnel trained and experienced in its operation and is not sold for consumer use in and around the home nor for use directly by the general public in food service locations. For equipment to be used by the general public, please contact the factory.

The Star-Max models 502Z and 502FZ Electric Hot Plates are equipped for the voltage indicated on the nameplate mounted on the front panel. This unit is designed to operate on alternating current (A.C.), two wire single phase service only. **DO NOT CONNECT TO DIRECT CURRENT (D.C.).**

#### Total Connected Load

502FZ - at 240 Volts, Wattage is 5200.  
at 208 Volts, Wattage is 3900.

502Z - at 240 Volts, Wattage is 4200.  
at 208 Volts, Wattage is 3150.

## INSTALLATION

For your protection, we recommend that a qualified electrician install this appliance. The electrician should be familiar with electrical installations and your local electrical requirements. The external wiring should be in conduit or an approved type of flexible cable and of suitable size to carry the load. The supply circuit should be properly fused and equipped with a means of disconnecting as required by local electrical code. The body of the hot plate should be grounded (Do not ground to a gas supply pipe). The connections are made in this unit at the pigtail leads located in the junction box on the back of the unit. To gain access to the pigtail leads remove cover on junction box.

## LOCATE THE UNIT

Do not install the unit closer than 1 inch from a side wall and/or closer than 1 inch from a rear wall.

## LEVELING UNIT

Level unit by adjusting the (4) feet for accurate and perfect line up with other Star-Max series units.



### CAUTION

## DO NOT INSTALL WITHOUT FEET.



### CAUTION

**USE ONLY FLAT BOTTOM PANS AND POTS! DO NOT USE RAISED BOTTOM UTENSILS OR BUCKETS! GOOD HEAT TRANSFER DEPENDS UPON GOOD CONTACT BETWEEN THE ELEMENT AND POT.**

Two (2) heating elements are used. For the 502FZ each element draws 2600 watts on 240 Volts and 1950 watts on 208 Volts. For the 502Z each element draws 2100 watts on 240 Volts and 1575 watts on 208 Volts. Each element is controlled by an infinite position switch. The right control knob controls the rear cooking element and the left control knob controls the front cooking element. On "HI" the element delivers uninterrupted full heat. Between "LO" and "5" any desired amount of heat can be obtained between 6% and 60% of full heat.

Signal lights are provided above the control knobs to give a visual check if either one or both heating units are turned on.

## **CLEANING**

The exterior surfaces can be kept clean and attractive by regularly wiping with a clean soft cloth. Any discoloration can be removed with a non-abrasive cleaner.

For model 502Z, the heating elements may be raised for access to the drip pans, which may be removed for cleaning and the bottom pan may be removed by sliding pan forward.

## **REPLACEMENT OF INFINITE CONTROL**

### **BE SURE POWER IS DISCONNECTED BEFORE ATTEMPTING TO SERVICE UNIT.**

1. Pull control knobs on front panel forward to remove.
2. Remove 4 screws from front panel and tilt front panel forwards.
3. Remove the nut that mounts the inoperative control and pull the control to the side.
4. Remove one wire at a time from the inoperative control and connect at the same terminal on the new control. Carefully check to see that proper wires have been connected to the terminals of the control. See attached wiring diagram.
5. Assemble new control to the front panel.

## **MAINTENANCE AND REPAIRS**

Contact the factory or one of its representatives or a local service company for service or maintenance if required.

### THOROUGHLY INSPECT YOUR UNIT ON ARRIVAL

This unit has been tested for proper operation before leaving our plant to insure delivery of your unit in perfect condition. However, there are instances in which the unit may be damaged in transit. In the event you discover any type of damage to your product upon receipt, you must immediately contact the transportation company who delivered the item to you and initiate your claim with same. If this procedure is not followed, it may affect the warranty status of the unit.

### LIMITED EQUIPMENT WARRANTY

All workmanship and material in Star products have a one (1) year limited warranty on parts & labor in the United States and Canada. Such warranty is limited to the original purchaser only and shall be effective from the date the equipment is placed in service. Star's obligation under this warranty is limited to the repair of defects without charge, by the factory authorized service agency or one of its sub-agencies. Models that are considered portable (see below) should be taken to the closest Star service agency, transportation prepaid.

- > Star will not assume any responsibility for loss of revenue.
- > On all shipments outside the United States and Canada, see International Warranty.
- \* The warranty period for the JetStar series six (6) ounce popcorn machines is two (2) years.
- \* The warranty period for the Chrome-Max Griddles is five (5) years on the griddle surface. See detailed warranty provided with unit.
- \* The warranty period for Teflon/Dura-Tec coatings is one year under normal use and reasonable care. This warranty does not apply if damage occurs to Teflon/Dura-Tec coatings from improper cleaning, maintenance, use of metallic utensils, or abrasive cleaners. This warranty does not apply to the "non-stick" properties of such materials.
- > This warranty does not apply to "Special Products" but to regular catalog items only. Star's warranty on "Special Products" is six (6) months on parts and ninety (90) days on labor.
- > This warranty does not apply to any item that is disassembled or tampered with for any purpose other than repair by a Star Authorized Service Center or the Service Center's sub-agency.
- > This warranty does not apply if damage occurs from improper installation, misuse, wrong voltage, wrong gas or operated contrary to the Installation and Operating instructions.
- > This warranty is not valid on Conveyor Ovens *unless* a "start-up/check-out" has been performed by a Factory Authorized Technician.

### PARTS WARRANTY

Parts that are sold to repair out of warranty equipment are warranted for ninety (90) days. The part only is warranted. Labor to replace the part is chargeable to the customer.

### SERVICES NOT COVERED BY WARRANTY

- |  |   |
|--|---|
| 1. Travel time and mileage rendered beyond the 50 mile radius limit  | 10. Voltage conversions   |
| 2. Mileage and travel time on portable equipment ( <i>see below</i> )  | 11. Gas conversions   |
| 3. Labor to replace such items that can be replaced easily during a daily cleaning routine, ie; removable kettles on fryers, knobs, grease drawers on griddles, etc. | 12. Pilot light adjustment  |
| 4. Installation of equipment   | 13. Miscellaneous adjustments   |
| 5. Damages due to improper installation  | 14. Thermostat calibration and by-pass adjustment   |
| 6. Damages from abuse or misuse  | 15. Resetting of circuit breakers or safety controls  |
| 7. Operated contrary to the Operating and Installation Instructions  | 16. Replacement of bulbs  |
| 8. Cleaning of equipment   | 17. Replacement of fuses  |
| 9. Seasoning of griddle plates   | 18. Repair of damage created during transit, delivery, & installation OR created by acts of God |

### PORTABLE EQUIPMENT

Star will not honor service bills that include travel time and mileage charges for servicing any products considered "Portable" including items listed below. These products should be taken to the Service Agency for repair:

- \* The Model 510F Fryer.
  - \* The Model 526TO Toaster Oven.
  - \* The Model J4R, 4 oz. Popcorn Machine.
  - \* The Model CFS Series Food Steamer.
  - \* The Model 526WO Warming Oven.
  - \* The Model 518CM & 526CM Cheese Melter.
  - \* The Model 12MC & 15MC & 18MCP Hot Food Merchandisers.
  - \* The Model 12NCPW & 15NCPW Nacho Chip/Popcorn Warmer.
  - \* All Hot Dog Equipment **except Roller Grills & Drawer Bun Warmers.**
  - \* All Nacho Cheese Warmers **except Model 11WLA Series Nacho Cheese Warmer.**
  - \* All Condiment Dispensers **except the Model CSD & HPD Series Dispenser.**
  - \* All Specialty Food Warmers **except Model 130R, 500, 11RW Series, and 11WSA Series.**
- ALL:**
- \* Pop-Up Toasters
  - \* Butter Dispensers
  - \* Pretzel Merchandisers
  - \* Pastry Display Cabinets
  - \* Nacho Chip Merchandisers
  - \* Accessories of any kind
  - \* Sneeze Guards
  - \* Pizza Ovens
  - \* Heat Lamps
  - \* Hot Cups
  - \* Pumps

The foregoing warranty is in lieu of any and all other warranties expressed or implied and constitutes the entire warranty.

### FOR ASSISTANCE

Should you need any assistance regarding the Operation or Maintenance of any Star equipment; write, phone, fax or email our Service Department. In all correspondence mention the Model number and the Serial number of your unit, and the voltage or type of gas you are using.

MATERIAL			FINISH		MODEL NO. 502/502F	PART NO. SK1331				
DR. DM	CK.	DATE 1/22/91	STAR MFG. INTERNATIONAL, INC.		TITLE WIRING DIAGRAM					
LIMITS UNLESS OTHERWISE NOTED FRACTIONS ± 1/64 DECIMALS ± .005			9325 OLIVE BOULEVARD ST. LOUIS, MO 63132		CHANGES	LTR	DATE	CHANGE	DR	
502F	502	502F		502			A	9/18/94	REDRAWN TO CAD 90 DEG. C WAS 60 DEG. C	BN
RATED WATTAGE	RATED WATTAGE	NOMINAL AMPS PER LINE WIRE		NOMINAL AMPS PER LINE WIRE						
5200 (240V)	4200 (240V)	208 V (1 PH)	240 V (1 PH)	208 V (1 PH)	240 V (1 PH)					
3900 (208V)	3150 (208V)	18.77	21.66	15.14	17.5					
FOR SUPPLY CONNECTIONS USE GA. SHOWN (OR LARGER)		AWG #10	AWG #10	AWG #12	AWG #10					

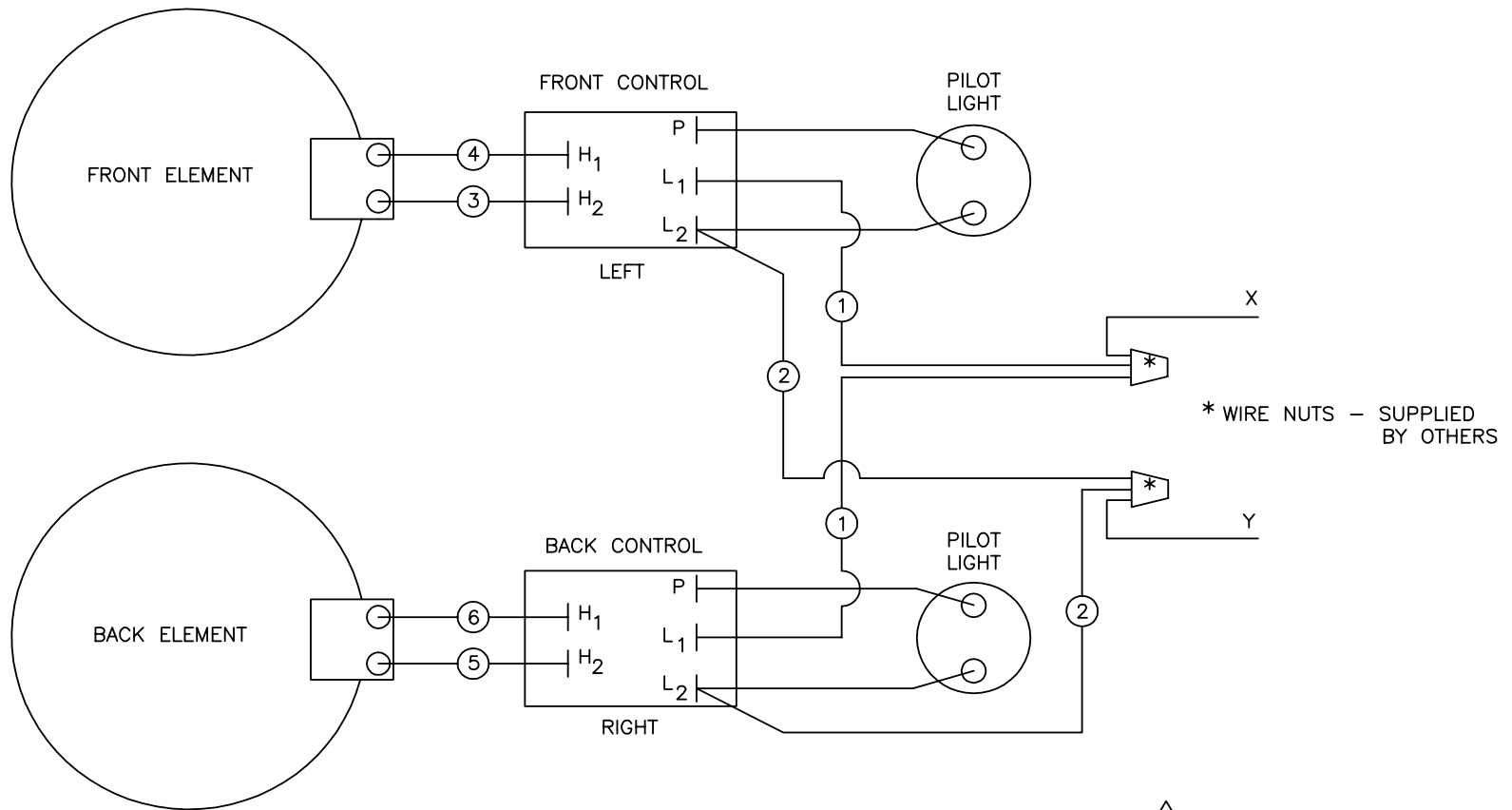

NOTE: FOR SUPPLY CONNECTIONS USE COPPER WIRE ONLY, SUITABLE FOR AT LEAST 90 DEG. C (194 DEG. F)

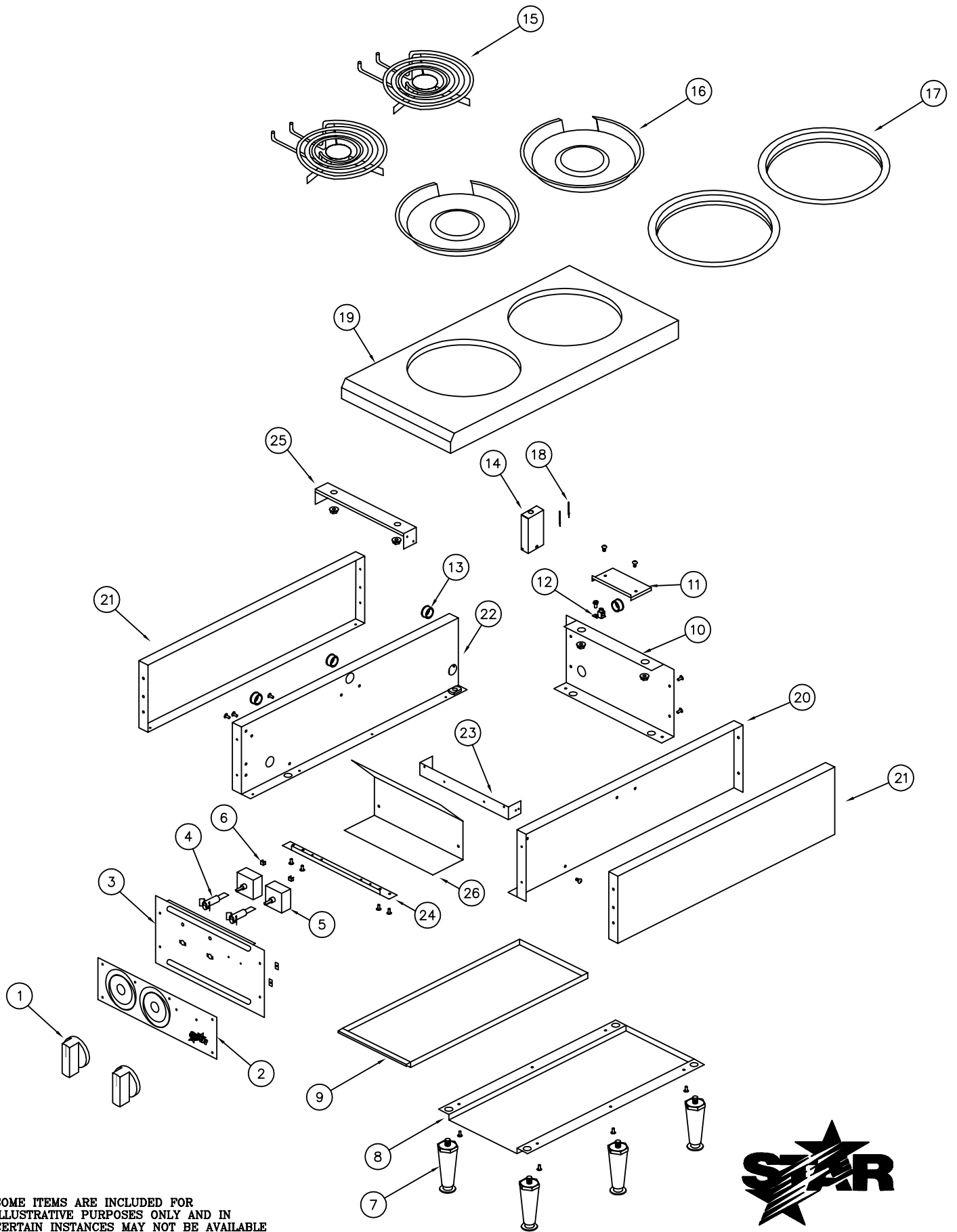

SOME ITEMS ARE INCLUDED FOR  
ILLUSTRATIVE PURPOSES ONLY AND IN  
CERTAIN INSTANCES MAY NOT BE AVAILABLE

This drawing contains information confidential  
to Star Manufacturing International, Inc.  
No reproduction or disclosure of its  
contents is permitted.

MODEL: 502Z

STAR MANUFACTURING INTERNATIONAL, INC.

SK1597

REV. 6-17-99 DR: T.L.



# PARTS LIST

EFFECTIVE 1/8/03 Rev. C

MODEL 502Z Star-Max Electric Hot Plate

Key Number	Part Number	Number Per Unit	Description
1	2R-Z1431	2	KNOB-THERMOSTAT
2	2M-Z6324	1	FRONT GRAPHIC
3	13-Z6315	1	FRONT PANEL
4	2J-Y7114	2	PILOT LIGHT
5	2J-6403	2	CONTROL-INFINITE 240V
6	2C-9938	2	ADAPTER-TERMINAL
7	2A-Z0314	4	FOOT 4" DIE CAST
8	13-Y7708	1	SLIDE, DRAWER
9	13-Y7694	1	DRAWER
10	13-502010	1	BACK WELD ASSEMBLY
11	G3-Y7788	1	COVER, HANDY BOX
12	2C-Y2344	1	TERMINAL-GROUND
13	2K-8043	4	BUSHING - HEYCO #5
14	13-Y7822	2	COVER-TERMINAL BLOCK
15	2N-Y7779	2	ELEMENT
16	2D-6470	2	PAN-REFLECTOR
17	2P-6468	2	RING-ELEMENT ADAPTER
18	13-Y7891	4	CHAIN STRAIN RELIEF
19	13-502020	1	502Z, 502ZS WELD ASSEMBLY
20	13-602004	1	LINER ASSY RIGHT
21	H3-Z1339	2	SIDE (LEFT/RIGHT)
22	13-502016	1	LINER ASSY LEFT
23	13-602005	1	CENTER ANGLE WELD ASSY
24	13-Y7403	1	ANGLE, FRONT BOTTOM
25	13-Y7405	1	ANGLE, TOP
26	13-Y7463	1	COVER CONTROL

**IMPORTANT: WHEN ORDERING, SPECIFY VOLTAGE OR TYPE GAS DESIRED  
INCLUDE MODEL AND SERIAL NUMBER**

PAGE 1  
OF 1

Some items are included for illustrative purposes only and in certain instances may not be available.



**Star Manufacturing International, Inc.**

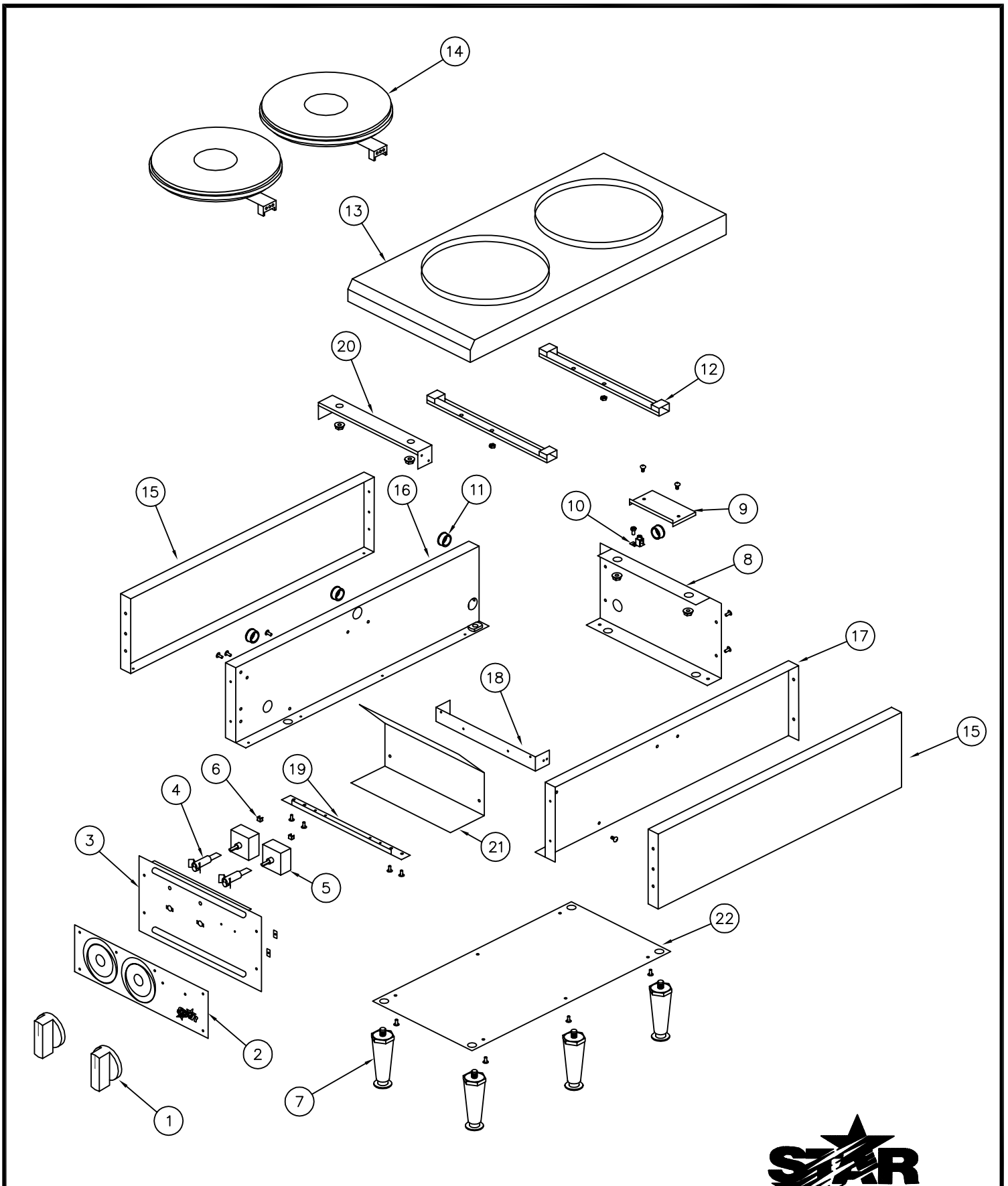

SOME ITEMS ARE INCLUDED FOR ILLUSTRATIVE PURPOSES ONLY AND IN CERTAIN INSTANCES MAY NOT BE AVAILABLE

This drawing contains information confidential to Star Manufacturing International, Inc. No reproduction or disclosure of its contents is permitted.

MODEL: 502FZ



STAR MANUFACTURING INTERNATIONAL, INC.

SK1596

REV. 6-17-99 DR: T.L.

# PARTS LIST

EFFECTIVE 1/8/03 Rev. C

MODEL 502FZ Star-Max Electric Hot Plate

Key Number	Part Number	Number Per Unit	Description
1	2R-1431	2	KNOB-THERMOSTAT
2	2M-Z6324	1	FRONT GRAPHIC
3	13-Z6315	1	FRONT PANEL
4	2J-Y7114	2	PILOT LIGHT
5	2J-6403	2	CONTROL-INFINITE 240V
6	2C-9938	2	ADAPTER-TERMINAL
7	2A-Z0314	4	FOOT 4" DIE CAST
8	13-502010	1	BACK WELD ASSEMBLY
9	G3-Y7788	1	COVER, HANDY BOX
10	2C-Y2344	1	TERMINAL-GROUND
11	2K-8043	4	BUSHING-HEYCO #5
12	11-162117	2	CLAMP ASSEMBLY
13	13-502021	1	502FZ TOP WELD ASSEMBLY
14	2N-Y3301	2	ELEMENT
15	H3-Z1339	2	SIDE (RIGHT/LEFT)
16	13-502016	1	LINER ASSY LEFT
17	13-602004	1	LINER ASSY RIGHT
18	13-602005	1	CENTER ANGLE WELD ASSY
19	13-Y7403	1	ANGLE FRONT BOTTOM
20	13-Y7405	1	ANGLE, TOP
21	13-Y7463	1	COVER CONTROL
22	13-Y7481	1	BOTTOM

**IMPORTANT: WHEN ORDERING, SPECIFY VOLTAGE OR TYPE GAS DESIRED  
INCLUDE MODEL AND SERIAL NUMBER**

PAGE 1  
OF 1

Some items are included for illustrative purposes only and in certain instances may not be available.



**Star Manufacturing International, Inc.**