



## SAFETY SYMBOL



These symbols are intended to alert the user to the presence of important operating and maintenance instructions in the manual accompanying the appliance.

---

## RETAIN THIS MANUAL FOR FUTURE REFERENCE NOTICE

Using any part other than genuine Star factory supplied parts relieves the manufacturer of all liability.

Star reserves the right to change specifications and product design without notice. Such revisions do not entitle the buyer to corresponding changes, improvements, additions or replacements for previously purchased equipment.

Due to periodic changes in designs, methods, procedures, policies and regulations, the specifications contained in this sheet are subject to change without notice. While Star International Holdings Inc., Company exercises good faith efforts to provide information that is accurate, we are not responsible for errors or omissions in information provided or conclusions reached as a result of using the specifications. By using the information provided, the user assumes all risks in connection with such use.

## MAINTENANCE AND REPAIRS

Contact your local authorized service agent for service or required maintenance.

Please record the model number, serial number, voltage and purchase date in the area below and have it ready when you call to ensure a faster service.

Model No. \_\_\_\_\_  
Serial No. \_\_\_\_\_  
Voltage \_\_\_\_\_  
Purchase Date \_\_\_\_\_

### Authorized Service Agent Listing

Reference the listing provided with the unit

or

for an updated listing go to:

**Website:** [www.star-mfg.com](http://www.star-mfg.com)  
**E-mail** [customerservice@star-mfg.com](mailto:customerservice@star-mfg.com)

### Service Help Desk

**Business Hours:** 8:00 am to 4:30 p.m. Central Standard Time

**Telephone:** (800) 264-7827

**Fax:** (314) 781-2714

**E-mail** [customerservice@star-mfg.com](mailto:customerservice@star-mfg.com)

**Website:** [www.star-mfg.com](http://www.star-mfg.com)

**Mailing Address:** Star Manufacturing International Inc.  
265 Hobson Street  
Smithville, TN 37166  
U.S.A

Specifications					
Electrical Specifications			Dimensions		
Model	Voltage	kW	Width	Depth	Height
501FF	208-240	1.95-2.60	12" (30.4cm)	17.25" (43.8cm)	10.7" (27.2cm)
502FF	208-240	3.90-5.20	12" (30.5cm)	28 (71.1cm)	11 5/8" (29.5cm)

## GENERAL OPERATING INSTRUCTIONS



This equipment is designed and sold for commercial use only by personnel trained and experienced in its operation and is not sold for consumer use in and around the home nor for use directly by the general public in food service locations. For equipment to be used by the general public, please contact the factory.

The Star-Max Electric Hot Plates are equipped for the voltage indicated on the nameplate mounted on the front panel. This unit is designed to operate on alternating current (A.C.), two wire single phase service only.



**DO NOT CONNECT TO DIRECT CURRENT (D.C.).**

### Total Connected Load:

501FF:           at 240 Volts, Wattage is 2,600.  
                      at 208 Volts, Wattage is 1,950.

502FF:           at 240 Volts, Wattage is 5,200.  
                      at 208 Volts, Wattage is 3,900.

## INSTALLATION

For your protection, we recommend that a qualified electrician install this appliance. The electrician should be familiar with electrical installations and your local electrical requirements. The external wiring should be in conduit or an approved type of flexible cable and of suitable size to carry the load. The supply circuit should be properly fused and equipped with a means of disconnecting as required by local electrical code. The body of the hot plate should be grounded (**Do not ground to a gas supply pipe**). The connections are made in this unit at the pigtail leads located in the junction box on the back of the unit. To gain access to the pigtail leads remove cover on junction box.



### LOCATE THE UNIT

Do not install the unit closer than 1 inch from a side wall and/or closer than 1 inch from a rear wall.

### LEVELING UNIT

Level unit by adjusting the (4) feet for accurate and perfect line up with other Star-Max series units.



**DO NOT INSTALL WITHOUT FEET.**



**USE ONLY FLAT BOTTOM PANS AND POTS! DO NOT USE RAISED BOTTOM UTENSILS OR BUCKETS! GOOD HEAT TRANSFER DEPENDS UPON GOOD CONTACT BETWEEN THE ELEMENT AND POT.**

NOTE: Using a 12" diameter or larger pan/pot may cause damage to the element or internal wiring. Such damages are not covered by warranty.

Two (2) heating elements are used. For the 501FF and 502FF each element draws 2,600 Watts on 240 Volts and 1,950 Watts on 208 Volts. Each element is controlled by an infinite position switch. The right control knob controls the rear cooking element and the left control knob controls the front cooking element for the 502FF. On "HI" the element delivers uninterrupted full heat. Between "LO" and "5" any desired amount of heat can be obtained between 6% and 60% of full heat.

Signal lights are provided above the control knobs to give a visual check of the corresponding heating element per each knob.



## **CLEANING**

Appliances must be disconnected from power supply during cleaning, or maintenance and when replacing parts. The exterior surfaces can be kept clean and attractive by regularly wiping with a clean soft cloth. Any discoloration can be removed with a non-abrasive cleaner. When appliance is installed in a bank of other appliances, it shall not be cleaned with a water jet or a steam cleaner.

## **REPLACEMENT OF INFINITE CONTROL**

**BE SURE POWER IS DISCONNECTED BEFORE ATTEMPTING TO SERVICE UNIT.**

1. Pull control knobs on front panel forward to remove.
2. Remove 8 screws from front panel and tilt front panel forwards.
3. Remove the nut that mounts the inoperative control and pull the control to the side.
4. Remove one wire at a time from the inoperative control and connect at the same terminal on the new control. Carefully check to see that proper wires have been connected to the terminals of the control. See attached wiring diagram.
5. Assemble new control to the front panel.

## **MAINTENANCE AND REPAIRS**

Contact the factory or one of its representatives or a local service company for service or maintenance if required.

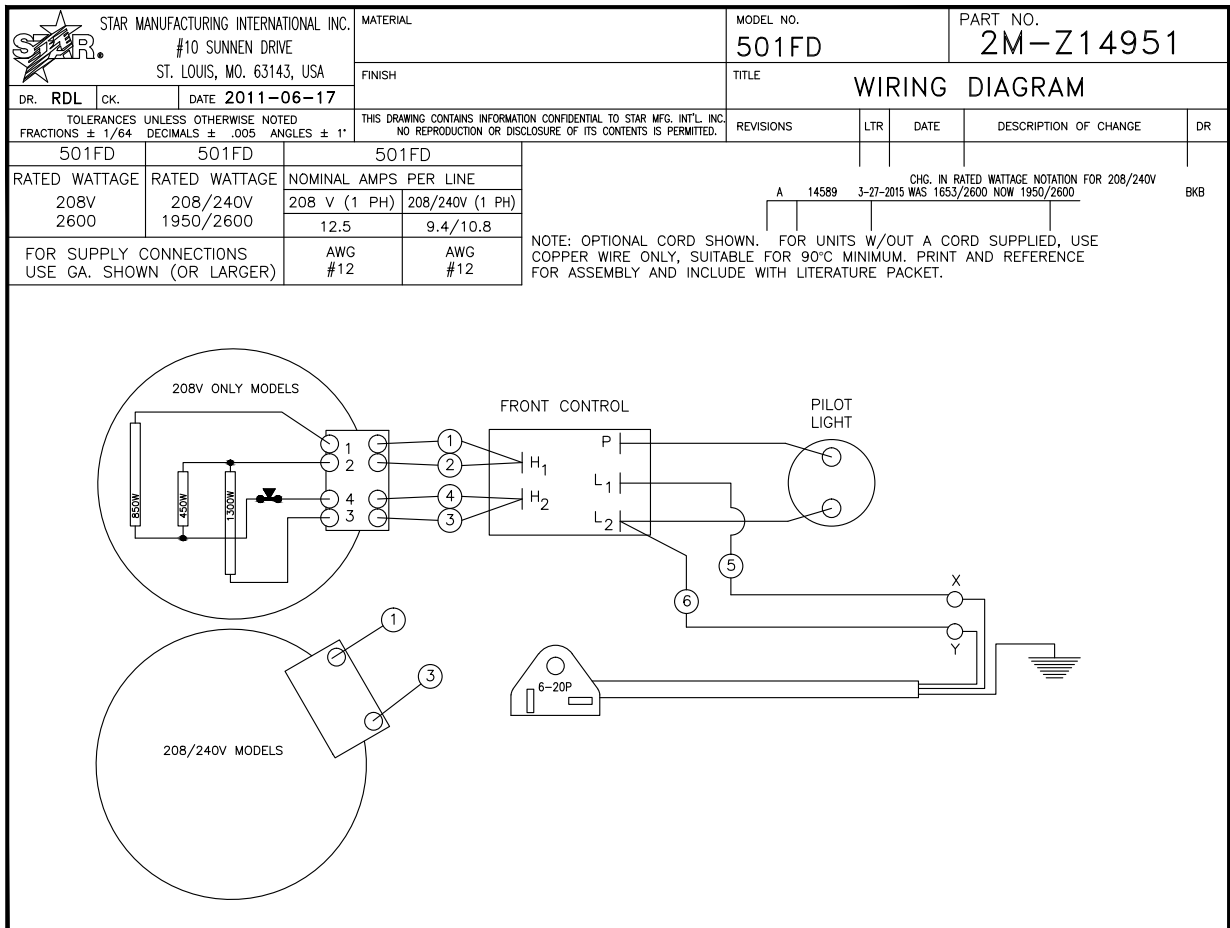
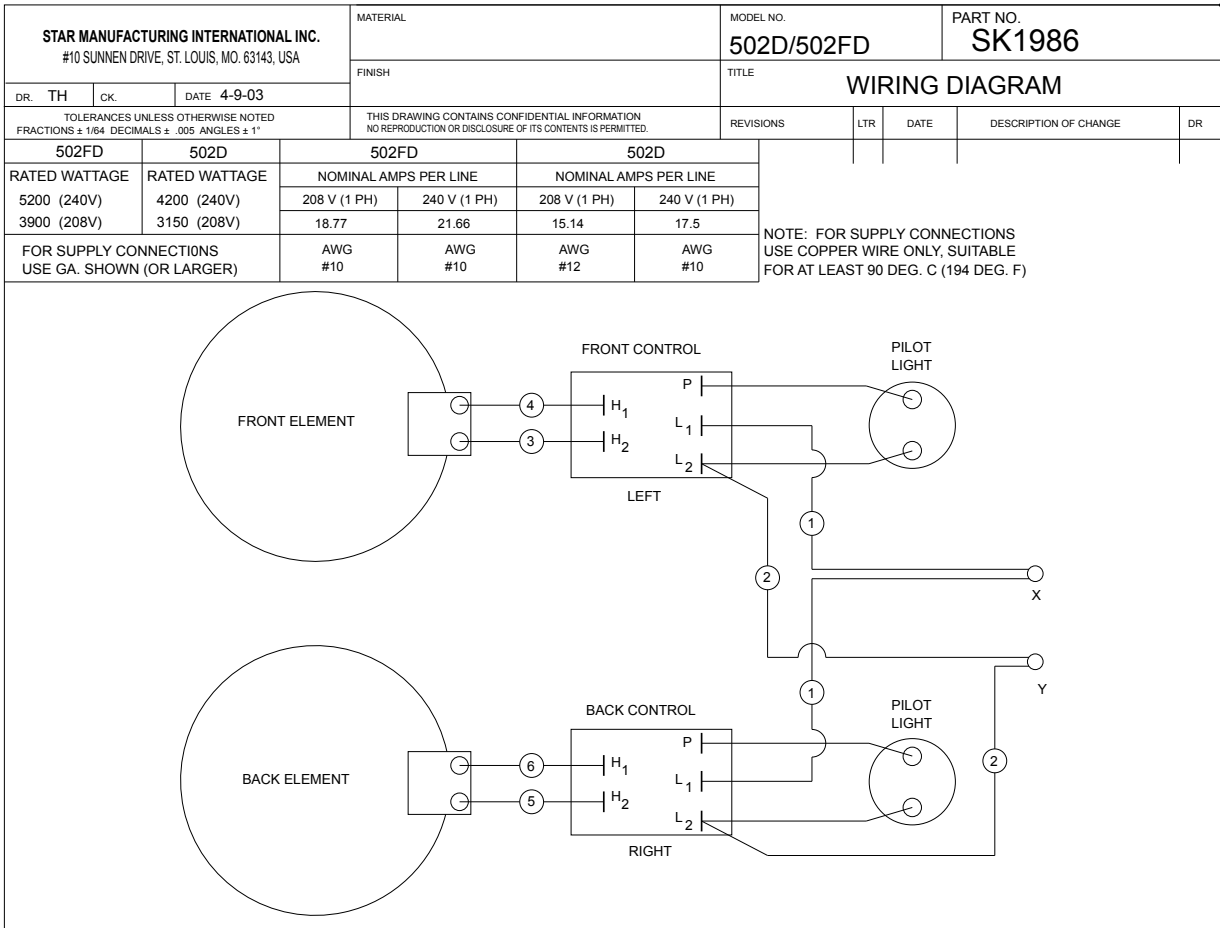

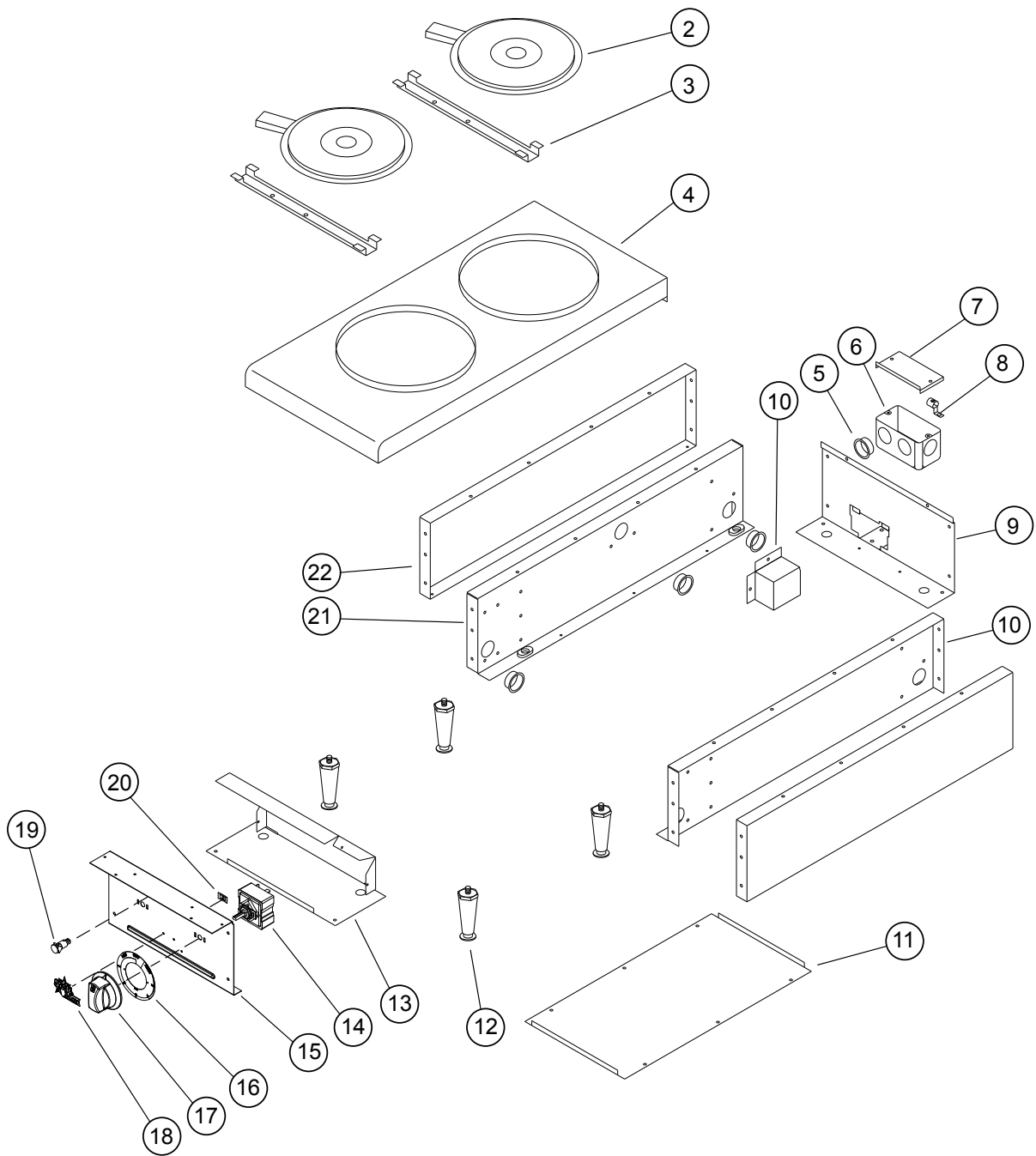

**MODEL 502FF**

**STAR MANUFACTURING INTERNATIONAL, INC.**  
 SK2593 06-05-12

# PARTS LIST

June 6, 2012, Rev. -

Model: Star-Max Electric Hot Plate				
Fig No	Part No	Qty	Description	Application
1	2N-11120-12	1	ELEMNT TK 208V 2600W	501FF (208/240V)
	2N-Y3301		ELEMENT 2600 WATTS 240V	501FF-208V
2	2N-Y3301	1	ELEMENT 2600 WATTS 240V	501FF
		2		502FF
3	I3-Z6169	2	ELEMENT CLAMP	502FF
4	I2-Z14946	1	TOP	501 SERIES
	I3-Z6176			502FF
5	2K-Z6183	3	BUSHING 1.125-S-MAX	501 SERIES
		4		502 SERIES
6	2E-Y7327	1	ELECTRICAL BOX	ALL
7	G3-Y7788	1	BOX COVER	ALL
8	2C-Y2344	1	GROUND LUG	ALL
9	I2-Z6170	1	REAR PANEL	ALL
10	G3-624303	1	SIDE LINER ASSEMBLY RIGHT	ALL
11	I3-Z6174	1	BOTTOM PANEL	502FF
12	2R-200716	4	LEG 2.5 IN METAL	501 SERIES
	2A-Z5942		FOOT	502 SERIES
13	I2-Z6172	1	CENTER WALL	ALL
14	2E-Z21563	1	CONTROL-INFINITE 240V	501 SERIES
		2		502 SEIES
15	I4-Z15489	1	FRONT PANEL	ALL
16	2M-Z15452	1	LABEL ELECT INF LG	501 SERIES
		2		502 SERIES
17	G3-624330	1	KNOB ASSEMBLY LG KEY	501 SERIES
		2		502 SERIES
18	2M-Z15804	1	STAR-MAX LOGO	ALL
19	2J-Y6690	1	PILOT LIGHT 240V	501 SERIES
		2		502 SERIES
20	2C-8477	3	CLIP .125 PO STL PHOS	ALL
21	I2-502023	1	SIDE LINER ASSEMBLY LEFT	ALL
22	G3-Z5945	2	SIDE PANEL	ALL
NA	2E-Z6168	1	WIRE SET	502FF

**IMPORTANT: WHEN ORDERING, SPECIFY VOLTAGE OR TYPE GAS DESIRED  
INCLUDE MODEL AND SERIAL NUMBER**

PAGE 1  
OF 1

Some items are included for illustrative purposes only and in certain instances may not be available.



**Star Manufacturing International, Inc.**

## LIMITED EQUIPMENT WARRANTY

Star Manufacturing [as well as its subsidiaries, Toastmaster and Holman] warranties new products to be free from defects in material and/or workmanship for a period of one [1] year from the date of original installation, except as noted below. Defects that occur as a result of normal use, within the time period and limitations defined in this warranty, will at Star's discretion have the parts replaced or repaired by Star or a Star-authorized service agency.

### THIS WARRANTY IS SUBJECT TO ALL LISTED CONDITIONS.

Repairs performed under this warranty are to be performed by a Star authorized service agency. Star will not be responsible for charges incurred or service performed by non-authorized repair agencies. In all cases, the nearest Star-authorized service agency must be used. Star will be responsible for normal labor charges incurred in the repair or replacement of a warranted product within 50 miles (80.5 km) of an authorized service agency. Time and expense charges for anything beyond that distance will be the responsibility of the owner. All labor will need to be performed during regular service hours. Any overtime premium will be charged to the owner. For all shipments outside the U.S.A. and Canada, please see the International Warranty for specific details. It is the responsibility of the owner to inspect and report any shipping damage claims, hidden or otherwise, promptly following delivery. No mileage or travel charges will be honored on any equipment that is deemed portable. In general, equipment with a cord and plug weighing less than 50 lb. (22.7 kg) is considered portable and should be taken or shipped to the closest authorized service agency, transportation prepaid.

## PORTABLE EQUIPMENT EXAMPLES

- 514LL fryer
- 15MC and 18MCP hot food merchandisers
- QCS1, QCS2, and RCS2 toasters
- 16PD-A pretzel merchandisers
- Condiment dispensers except HPD- and SPD-series models
- All pop-up toasters
- All pastry display cabinets
- All heat lamps
- J4R popcorn machine
- 12NCPW and 15NCPW nacho merchandisers
- Nacho cheese warmers except 11WLA-series models
- Specialty food warmers except 130R, 11RW, and 11WSA models
- All butter dispensers
- All nacho chip merchandisers
- All accessories

## CONTACT

Should you require any assistance regarding the operation or maintenance of any Star equipment; write, phone, fax or email our service department. In all correspondence mention the model number and serial number of your unit, as well as the voltage or type of gas you are using.

Business hours are 8:00 a.m. to 4:30 p.m. Central Standard Time (CST)

Telephone: (800)-264-7827

Fax: (314)-781-2714

Email: [Customerservice@star-mfg.com](mailto:Customerservice@star-mfg.com)

[www.star-mfg.com](http://www.star-mfg.com)

## WARRANTY EXCLUSIONS

### THE FOLLOWING WILL NOT BE COVERED UNDER WARRANTY.

- Any product which has not been used, cleaned, maintained, or installed in accordance with the directions published in the appropriate installation sheet and/or owner's manual as well as national and local codes, including incorrect gas, electrical, or water connection. Star is not liable for any unit which has been mishandled, abused, misapplied, subjected to chlorides, harsh chemicals, or caustic cleaners, damaged from exposure to hard water, modified by unauthorized personnel, damaged by flood, fire, or other acts of nature [or God], or which have an altered or missing serial number.
- Installation, labor, and job checkouts, calibration of heat controls, air and gas burner/bypass/pilot adjustments, gas or electrical system checks, voltage and phase conversions, cleaning of equipment, or seasoning of griddle surface.
- Replacement of fuses or resetting of circuit breakers, safety controls, or reset buttons.
- Replacement of broken or damaged glass components, quartz heating elements, and light bulbs.
- Labor charges for all removable parts in gas charbroilers and hotplates, including but not limited to burners, grates, and radiants.
- Any labor charges incurred by delays, waiting time, or operating restrictions that hinder a service technician's ability to perform service.
- Replacement of items subject to normal wear or items that can easily be replaced during a daily cleaning routine, such as but not limited to knobs, bulbs, fuses, quartz heating elements, baskets, racks, and grease drawers.
- Components that should be replaced when damaged or worn, but have been field-repaired instead [eg. field-welded fry pots]
- Any loss of business or profits.

PRODUCTS	PARTS	LABOR
Star-Ultra Max® fryers, griddles, charbroilers, and hotplates	2 years	2 years
Star-Max® fryers, griddles, charbroilers, and hotplates	2 years	2 years
Jetstar® popcorn poppers	2 years	2 years
Staltek™ roller grill coatings	5 years	
Cast iron grates, burners; and burner shields	180 days	
Star, Toastmaster, or Holman parts sold to repair equipment	90 days	
Service First	1 year	