

STAR MANUFACTURING INTERNATIONAL, INC.
9325 Olive Blvd., P.O. Box 8492
St. Louis, MO 63132

MODELS 3W, 7W & 11W SERIES FOOD WARMERS

CAUTION: This equipment is designed and sold for commercial use only by personnel trained and experienced in its operation and is not sold for consumer use in and around the home nor for use directly by the general public in food service locations.

GENERAL INSTALLATION DATA

These food warmers are equipped for the voltage and wattage indicated on the nameplate mounted to the back panel and are designed for use on alternating current (AC) only.

DO NOT CONNECT TO DIRECT CURRENT (DC)

OPERATING INSTRUCTIONS
(3 1/2 Qt. & 7 Qt. Models)

These warmers are designed to use stainless steel serving bowl purchased as an option. Follow these simple steps for setting up the warmer, using stainless steel bowl.

1. Place bowl lifter spring in black water bowl and fill water bowl with one quart of hot water.
2. Turn warmer on.
3. On pump model, PRE-HEAT fudge or cheese before inserting pump. Pump will NOT function if fudge or cheese is too thick.
4. Place bowl into unit. If using No. 10 tin, open tin and pour contents into stainless steel bowl. Bowl lifter spring should be centered under container.
5. Place lock ring over container, or pump into fudge or cheese, press down turning right or left until top locks into unit.
BE SURE BOWL LIFTER SPRING IS PLACED INSIDE WATER BOWL BEFORE INSERTING CONTAINER. (Not used on 7 Qt. Models)
6. Because the consistency of different foods varies, and because liquids and solids absorb heat at different rates, it is impractical to specify an exact dial setting. However, the letter "V" is in the center of the serving range and at this point the temperature is approximately 145 F, the proper holding temperature for fudge. When the dial is set at the letter "N" the temperature is approximately 170 F, the proper holding temperature for foods.
7. Turn the control to the extreme left position when not in use.

On heated spout models, DO NOT touch the pump spout heater casting without heat insulating mitten or other means of burn prevention. This casting is very hot once the warmer is heated. Follow these simple steps to install the pump into the heated spout casting.

1. a. Remove pump from warmer.
 b. Swing the retainer, fastened to the pump spout heater casting, down.
 c. Press down on pump plate and turn pump counterclockwise until notches in pump plate line up with bumps on black bowl.
 d. Lift pump from bowl.
2. Grasp the plastic knob at the rear of the spout heater casting and swing the spout heater casting up until it latches in up position.



3. Open tin and remove paper label.
4. Place bowl lifter spring in black water bowl and fill water bowl with one quart of hot water.
5. Turn on warmer.
6. PRE-HEAT CHEESE before inserting pump. Pump will NOT function if cheese is too thick.
7. BE SURE BOWL LIFTER SPRING IS PLACED INSIDE WATER BOWL BEFORE INSERTING CONTAINER.
8. Place tin or bowl into unit. Bowl lifter spring should be centered under container.
9. Grasp the retainer knob of the spout heater casting and swing it toward you to release the spout heater casting, then swing the casting down.
10. a. Place pump in tin or bowl and line up notches in pump plate with bumps on black bowl.
 b. Press down on pump plate until notches in plate are below bumps on black bowl and turn pump clockwise until pump spout engages groove in spout casting.
 c. Swing lever up to prevent pump spout from disengaging.



OPERATING INSTRUCTIONS
(11 Qt. Models)

1. Before using warmer clean the water food bowl and any accessories furnished with warmer.
2. Do not operate the warmer dry. Place 24 ounces of water in the water bowl and add water as required to maintain water level. Place pre-cooked food in a standard 11 quart inset and insert into water bowl.
3. Temperature Control: The temperature control on these warmers is a combination On/Off switch and thermostatic heat control. The "OFF" position will turn off the electric current to the heating element.
4. If PRE-HEATING IS DESIRED SET THE CONTROL AT "HI" for approximately 10 minutes. Prolonged "HI" setting may result in overcooking or scorching of certain foods. Preheat cheese before inserting a pump. The pump will not function if cheese is too thick.
5. Set the dial to the number required to maintain the temperature desired. Because the consistency of different foods varies, and because liquids and solids absorb heat at different rates, it is impractical to specify the exact dial setting. Therefore, we have indicated the setting with a series of numbers. A little experience will give you the proper setting for various foods you are serving.
6. Turn the control to the "OFF" position when the unit is not in use. CAUTION: DO NOT OVER-HEAT THE UNIT. If you do, it will take considerable time to cool to the proper temperature.

PUMP SPOUT HEATER The pump spout heater casting keeps cheese left in the pump spout at or above 140 F when warmer is allowed to heat for 40 minutes prior to vending through pump. This prevents dispensing cold dried cheese. DO NOT touch the pump spout heater casting, without heat insulating mitten or other means of burn prevention, since this casting is very hot, once the warmer is heated.

DIAL-A-HEAT TEMPERATURE CONTROL Your new Star Food Warmer has the exclusive Dial-A-Heat temperature control providing a selection of temperatures to take care of any serving requirements.

NOTE: The letter "V" is in the center of the serving range and at this point the temperature is approximately 145 F, the proper holding temperature for fudge. When the dial is set at the letter "N" the temperature is approximately 170 F, the proper holding temperature for foods.

IMPORTANT: TO INCREASE temperature - turn knob to right. TO DECREASE temperature - turn knob to left. TO CUT OFF heat - turn knob to extreme left, to "OFF" position.

HIGH HEAT For quick build up of temperature, turn knob as far to the right as it will go. After contents are heated turn knob left to desired position.

CAUTION: Do not keep unit on HIGH HEAT for more than 45 minutes, as the food may become overheated. Check water level frequently. DO NOT OPERATE UNIT WITHOUT WATER!

HELPFUL HINTS FOR BETTER SERVICE The food product you serve in this warmer, as packed by the manufacturer, represents a high standard of quality and this quality should be protected by following the recommendations of the packer in the preparation and serving of the product.

CLEAN WARMER THOROUGHLY EVERY DAY Clean and dry the element bowl inside the warmer every night. Use a soft cloth and mild soap to keep exterior surfaces

bright and shining. To keep the inside surface of the element bowl clean, use S.O.S or Brillo pads as often as necessary. Do not use detergents, strong abrasives or metal scouring pads on exterior surface of warmer. DO NOT IMMERSE IN WATER AT ANY TIME.

LIGHT BULB & SIGN REPLACEMENT The front panel of the warmer is easily removed to permit light bulb or sign replacement. Be sure to disconnect the power cord from the wall socket before removing the front panel. To remove front panel, remove the two (2) screws in the sign retainer, fastened to the bottom. The sign may now be removed. The light bulbs are 15 watt appliance type, medium base, screw type, which are available through your local variety or hardware store.

PARTS

Order parts from your local Star Franchised Service Center. Specify model number and serial number of warmer when ordering.

3WL

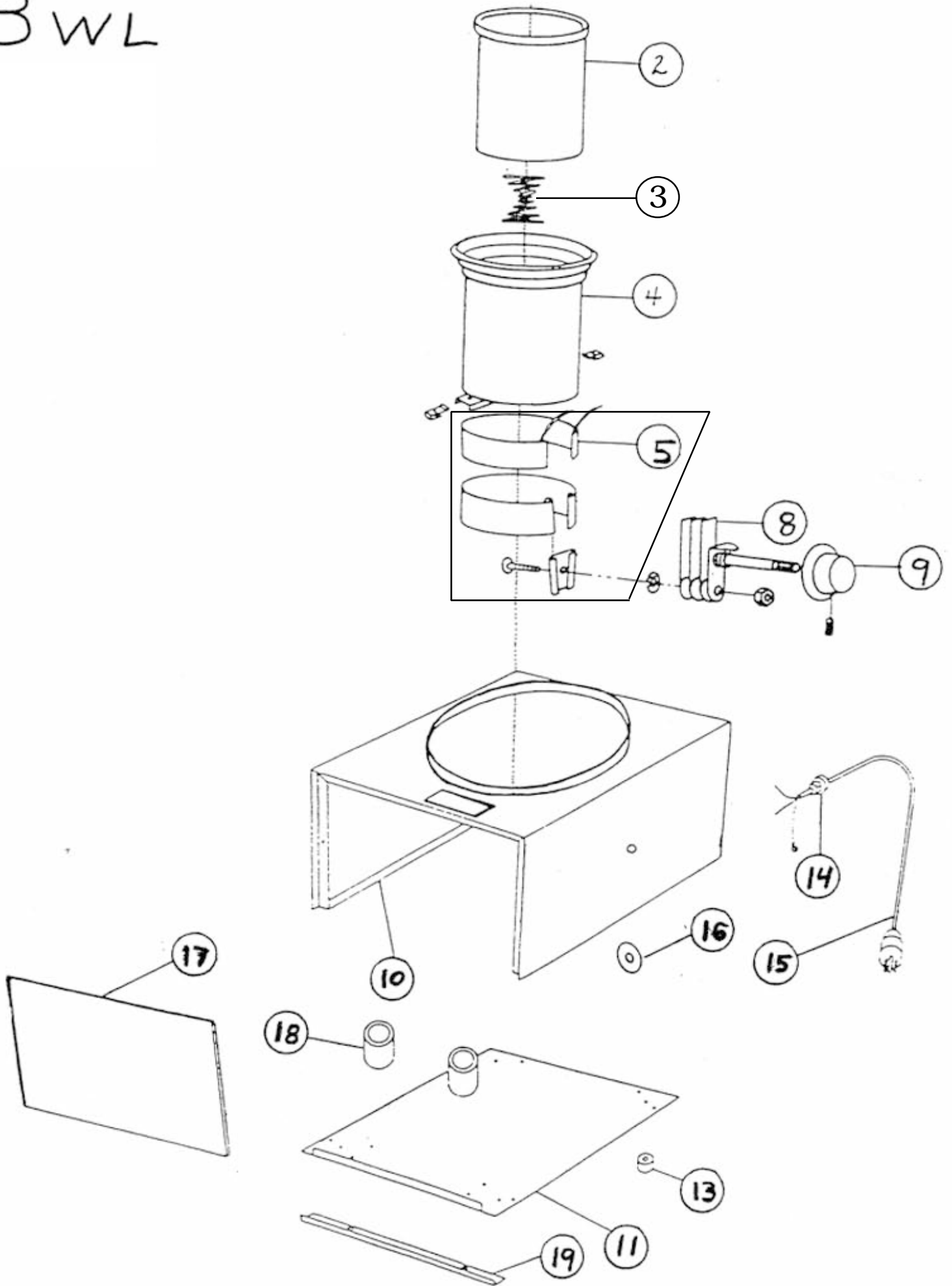

MODEL 8N-3WL & 3WL-NHS Series

Key Number	Part Number	Number Per Unit	Description
	2R-H5228	1	Knob w/o Screw (not shown) 3WL-BQ, C, CD, F, N, S, RIC
	2C-H1506	1	Screw - Knob (not shown) 3WL-BQ, C, CD, F, N, S, RIC
	N2-H5059	1	Cover - Notched (not shown) 3WL-BQ, C, CD, F, N, S, RIC
	N2-S5414	1	Lock Ring & Bracket (not shown) 3WL-BQ, C, CD, F, N, S, RIC
2	2D-H6295		Bowl - Stainless Steel (optional) (Vollrath # 78730)
3	2P-H6452	1	Compression Spring
4-8	N2-S6039	1	Element Bowl w/Element & Thermostat
4	2D-H5452	1	Element Bowl (cold rolled steel w/enamel coating)
	2C-H1017	2	Speed nut
5	N2-S8800	1	Element Replacement Kit (120V)
8	2T-Y6299	1	Thermostat
9	2R-H5948	1	Knob - Thermostat w/Screw
10	N2-S7933	1	Body Assembly 3WL-BQ, C, CD, F, FP, N, NP, S, RIC, DBP, GFP
	N2-S7934	1	Body Assembly 3WL-NHS
11	N2-Y6150	1	Bottom Panel
13	2I-H7685	4	Foot
14	2K-H5417	1	Bushing - Cord
15	Z1-S9003	1	Lead-In-Cord
16	2M-H7080	1	Decal - Thermostat
17	2M-H7508-8	2	Plexiglass - Clear
	2M-Y5801	1	Sign - Bar-B-Q 3WL-BQ
	2M-Y5803	1	Sign - Chili 3WL-C
	2M-Y5805	1	Sign - Chili Dog 3WL-CD
	2M-Y5799	1	Sign - Hot Fudge 3WL-F, FP
	2M-Y3334	1	Sign - Nachos (picture only-no words) 3WL-N, NP
	2M-Y5827	1	Sign - Soup 3WL-S
	2M-Y3930	1	Sign - Rico Nacho 3WL-RIC
	2M-Y5809	1	Sign - Delicious Buttered Popcorn 3WL-DBP
	2M-Y5808	1	Sign - Golden Flavored Popcorn 3WL-GFP
			(All Signs are 11" X 8-1/2" and must be cut to size)
	2S-H7360	2	Light Bulb (25W)
18	2E-Y5146	1	Socket w/Leads (10")
	2E-Y5147	1	Socket w/Leads (18")
19	N2-H7531	1	Bottom Trim Angle
	2E-Y6144	1	Switch - On/Off
	N2-30115		Heated Spout Kit (less Pump) (Turns 3WL-NP into 3WL-NHS)

IMPORTANT: WHEN ORDERING, SPECIFY VOLTAGE OR TYPE GAS DESIRED
INCLUDE MODEL AND SERIAL NUMBER

PAGE 1
OF 2

Some items are included for illustrative purposes only and in certain instances may not be available.



Star Manufacturing International, Inc.

MODEL 8N-3WL & 3WL-NHS Series

Key Number	Part Number	Number Per Unit	Description
	2K-Y1139	1	Bushing - Snap 3WL-NHS
	2I-Y5162	1	Gasket - Casting 3WL-NHS
	N2-Y5156	1	Casting Support 3WL-NHS
	2R-Y5167	1	Knob - Casting 3WL-NHS
	N2-Y6352	1	Spout Casting 3WL-NHS
	2N-Y4440	1	Element Cartridge 3WL-NHS
	N2-Y5159	1	Cover - Element 3WL-NHS
	2P-Y5932	1	Bearing Plain 3WL-NHS
	2R-Y1334	1	Knob - Spout Lever 3WL-NHS
	N2-Y5158	1	Spacer - Lever 3WL-NHS
	N2-Y5160	1	Lever 3WL-NHS
	N2-Y5161	1	Bracket - Retainer 3WL-NHS
	N2-Y5929	1	Spacer - Tube 3WL-NHS
	N2-S6397	1	Ladle - 1-1/2 oz. 3WL-F, CD, N, RIC
	O1-S5423	1	Ladle - 4 oz. 3WL-BQ, C, S
	N2-S5416		Ladle - 3/4 oz. (optional)
	N2-61000	1	Pump (3P-F or 3P-N) 3WL-FP, NP, NHS
	N2-61009	1	Pump (3P-B) 3WL-DBP, GFP
	2P-Y6211	1	Brush - Pump (18" long) 3WL-DBP, GFP, FP, NP, NHS

IMPORTANT: WHEN ORDERING, SPECIFY VOLTAGE OR TYPE GAS DESIRED
INCLUDE MODEL AND SERIAL NUMBER

PAGE 2
OF 2

Some items are included for illustrative purposes only and in certain instances may not be available.



Star Manufacturing International, Inc.

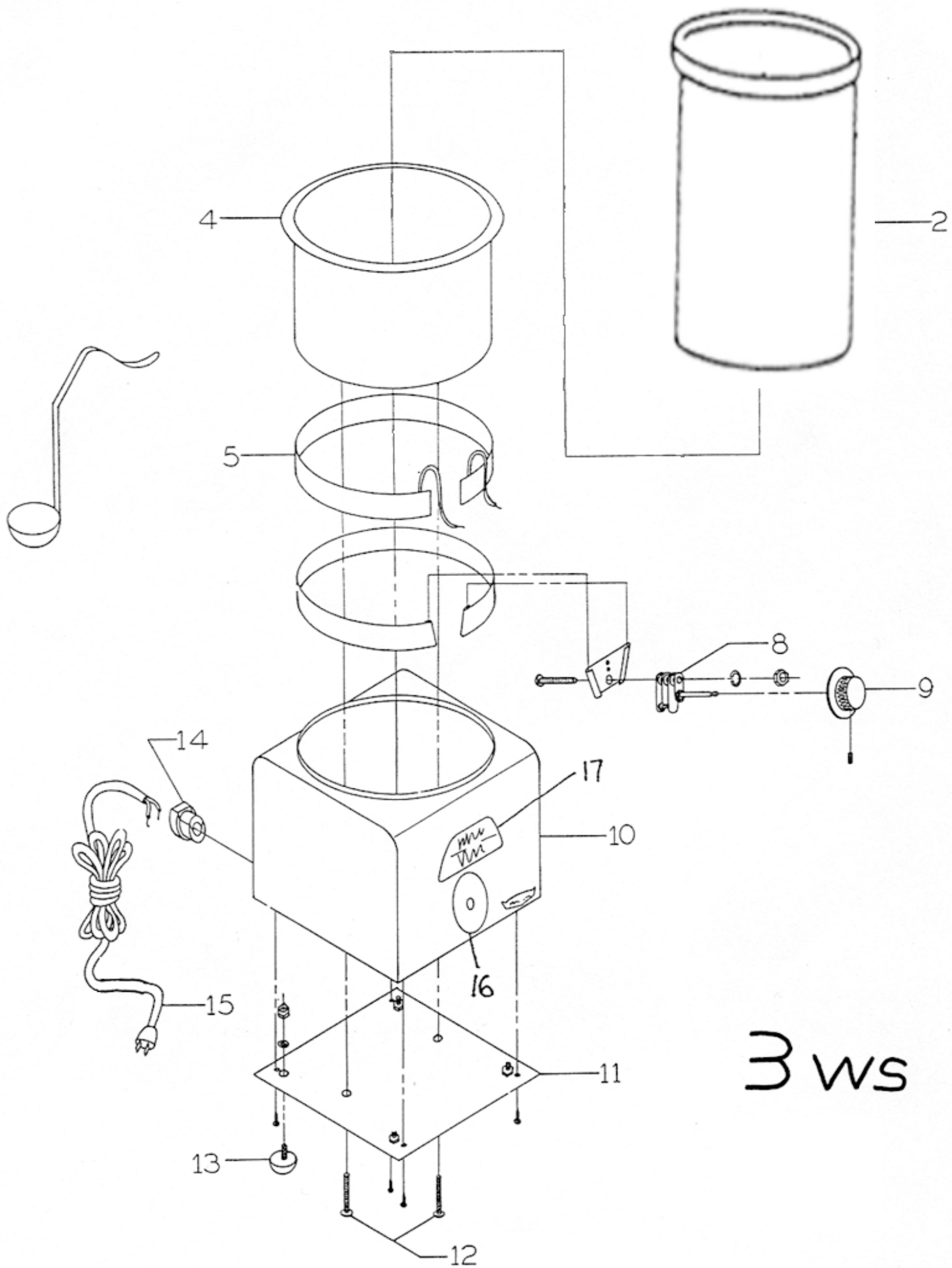

3 ws

MODEL 8N-3WS & 3WS-HS Series

Key Number	Part Number	Number Per Unit	Description	
	2R-H5228	1	Knob w/o Screw (not shown)	3WS
	2C-H1506	1	Screw - Knob (not shown)	3WS
	N2-H5059	1	Cover - Notched (not shown)	3WS
	N2-S5414	1	Lock Ring & Bracket (not shown)	3WS
2	2D-H6295		Bowl - Stainless Steel (optional) (Vollrath # 78730)	
	2P-H6452	1	Compression Spring (not shown)	
4-8	N2-S6039	1	Element Bowl w/Element & Thermostat	
4	2D-H5452	1	Element Bowl (cold rolled steel w/enamel coating)	
	2C-H1017	2	Speed nut	
5	N2-S8800	1	Element Replacement Kit (120V)	
8	2T-Y6299	1	Thermostat	
9	2R-H5948	1	Knob - Thermostat w/Screw	
10	N2-S7933	1	Body Assembly	3WS, 3WS-P
	N2-S7934	1	Body Assembly	3WS-HS
	N2-30101	1	Front Panel Assembly	
11	N2-Y6150	1	Bottom Panel	
13	2I-H7685	4	Foot	
14	2K-H5417	1	Bushing - Cord	
15	Z1-S9003	1	Lead-In-Cord	
16	2M-H7080	1	Decal - Thermostat	
17	2M-Y5868	1	Sign - Packet (Includes BBQ, Butterscotch, Chili, Chili Dog, Fudge, Nachos, Soup & Soup Du Jour)	
	2E-Y6144	1	Switch - On/Off	
	N2-30115		Heated Spout Kit (less Pump) (Turns 3WS-P into 3WS-HS)	
	N2-S6397	1	Ladle - 1-1/2 oz.	3WS
	O1-S5423	1	Ladle - 4 oz. (optional)	
	N2-S5416		Ladle - 3/4 oz. (optional)	
	N2-61000	1	Pump (3P-F or 3P-N)	3WS-P, 3WS-HS
	2P-Y6211	1	Brush - Pump (18" long)	3WS-P, 3WS-HS

IMPORTANT: WHEN ORDERING, SPECIFY VOLTAGE OR TYPE GAS DESIRED
INCLUDE MODEL AND SERIAL NUMBER

PAGE 1
OF 2

Some items are included for illustrative purposes only and in certain instances may not be available.



Star Manufacturing International, Inc.

MODEL 8N-3WS & 3WS-HS Series

Key Number	Part Number	Number Per Unit	Description	
	2K-Y1139	1	Bushing - Snap	3WS-HS
	2I-Y5162	1	Gasket - Casting	3WS-HS
	N2-Y5156	1	Casting Support	3WS-HS
	2R-Y5167	1	Knob - Casting	3WS-HS
	N2-Y6352	1	Spout Casting	3WS-HS
	2N-Y4440	1	Element Cartridge	3WS-HS
	N2-Y5159	1	Cover - Element	3WS-HS
	2P-Y5932	1	Bearing Plain	3WS-HS
	2R-Y1334	1	Knob - Spout Lever	3WS-HS
	N2-Y5158	1	Spacer - Lever	3WS-HS
	N2-Y5160	1	Lever	3WS-HS
	N2-Y5161	1	Bracket - Retainer	3WS-HS
	N2-Y5929	1	Spacer - Tube	3WS-HS

IMPORTANT: WHEN ORDERING, SPECIFY VOLTAGE OR TYPE GAS DESIRED
INCLUDE MODEL AND SERIAL NUMBER

PAGE 2
OF 2

Some items are included for illustrative purposes only and in certain instances may not be available.



Star Manufacturing International, Inc.

INSTRUCTION SHEET Y6113 12/91
 MODELS 3P-N, 3P-B, 3P-F and 11P-N Pumps

N2-61000 = 3P-N & 3P-F
 N2-61009 = 3P-B
 N2-61007 = 11P-N

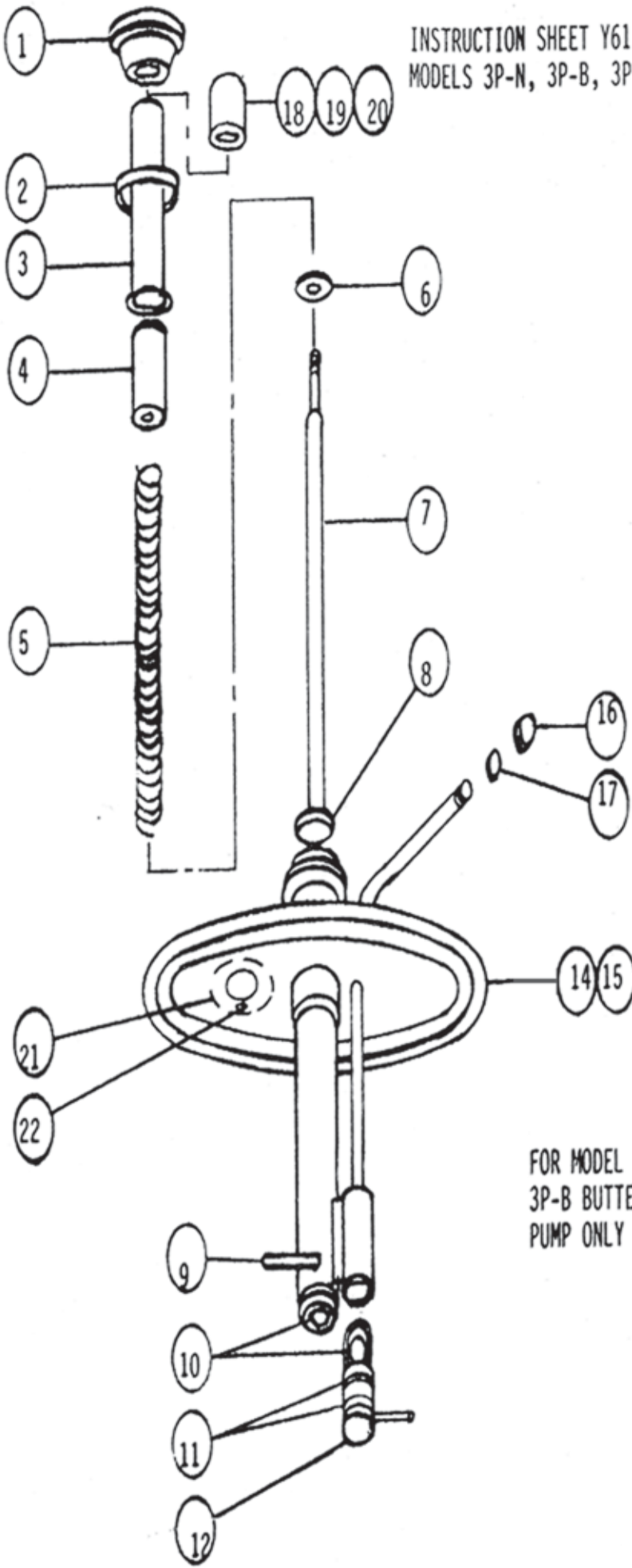

<u>ITEM</u>	<u>PART NUMBER</u>	<u>DESCRIPTION</u>
1	2R-Y4145	Knob
2	2A-Y4133	Nut- Cylinder Sleeve
3	2V-Y4138	Plunger Rod Shield
4	2A-Z0718	Guide - Plunger
5	2P-Z0830	Spring - Compression
6	N2-Y4146	Washer- Spring Compress
7	N2-S5552	Pump Plunger Assembly
8	2I-Y4143	O-Ring- Piston
9	N2-Y6190	Pin-Tube
10	2P-Y6196	Ball-Valve
11	2I-Y6214	O-Ring plug
12	N2-61002	Plug Assembly
14	N2-61006	Pump and plate assembly for model 11P-N Nacho pump.
15	N2-61008	Pump and plate assembly for model 3P-B Butter pump.
16	2P-Y6108	Cap- Tube
17	2I-Y6110	Gasket - Cap
18	N2-Y6122	Spacer - 1/4 Ounce
19	N2-Y6123	Spacer - 1/2 Ounce
20	N2-Y6124	Spacer - 3/4 Ounce
21	N2-H7724	Cover - Hole
22	2C-4102	Rivet

FOR MODEL
 3P-B BUTTER
 PUMP ONLY

MATERIAL ~
 DR. B.N. CK. DATE 3/17/92
 LIMITS UNLESS OTHERWISE NOTED
 FRACTIONS ± 1/84 DECIMALS ± .005

FINISH ~
 STAR MFG. INTERNATIONAL, INC.
 9325 OLIVE BOULEVARD ST. LOUIS, MO 63132

MODEL NO. 3WL/S, 7WL/S PART NO. ~
 TITLE WIRING DIAGRAM
 CHANGES LTR DATE CHANGE DR

B	3/17/92	REDRAWN TO CAD, ADDED EUROPEAN VERSION	B.N.
C	3/27/92	DELETE "F" WIRE ASSY.	B.N.

3WL/S, 7WL/S

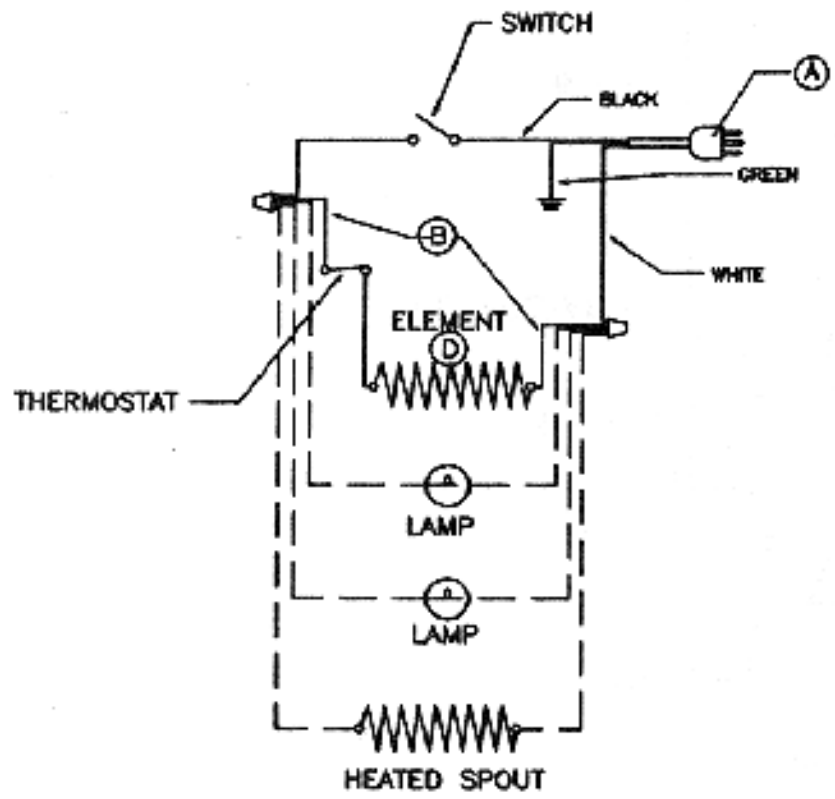

- (A) LEAD IN CORD ASSEMBLY
- (B) LEAD WIRE ASSEMBLY (2 REQ'D)
- (D) HEATING ELEMENT ASSEMBLY

LAMPS - (3WL, 7WL SERIES ONLY)
 HEATED SPOUT (3WS-HS, 3WL-RIC HS 120V, 3WS-HS CSA, 3WL-NHS 120V, 3WL-NHS 120V CSA ONLY)

3WL, 7WL WIRING DIAGRAM
 240V - EUROPE

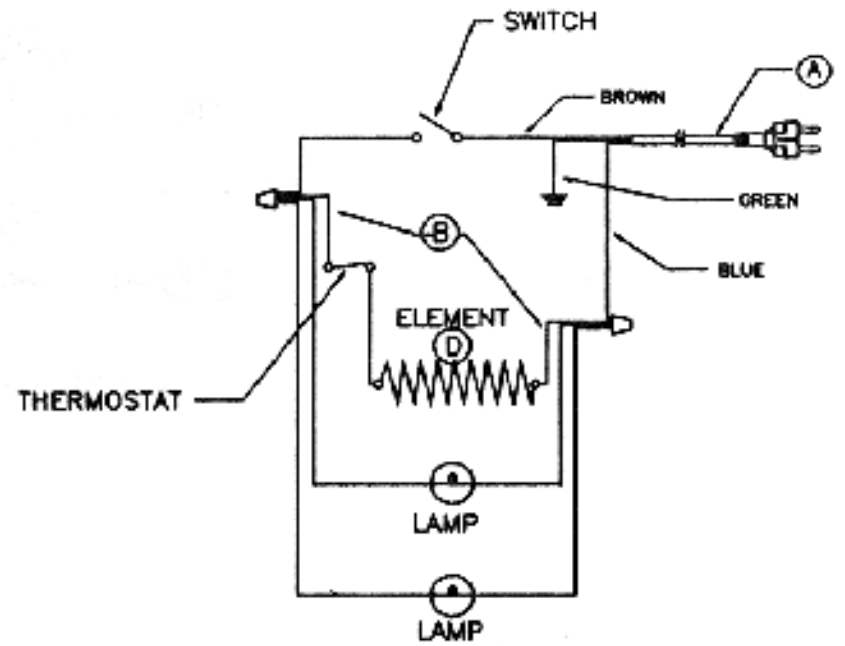

- (A) LEAD IN CORD ASSEMBLY
- (B) LEAD WIRE ASSEMBLY (2 REQ'D)
- (D) HEATING ELEMENT ASSEMBLY

NACHO CHEESE RECIPE

There are many different kinds and brands of cheese that may be used with this NACHO CHEESE WARMER. Many brands have Jalapeno peppers already blended into them and may be used straight from the can. If you wish to create your own distinctive Nacho Cheese Sauce, you may want to start with the recipe listed below.

NACHO CHEESE

- 1 #10 tin processed cheese spread (110 oz.)
- 7 oz. Jalapeno pepper juice
- 4 Jalapeno peppers
- 7 oz. water

Open can of cheese, remove about 20 oz. of cheese. Place can in eight quart pot. Pour enough water into the pot to go about $\frac{3}{4}$ way up outside of tin. Place pot over heat. Warm and stir the cheese until it reaches approximately 140°F.

Place the 7 oz. of pepper juice and 4 Jalapeno peppers into blender and liquify. Add 7 oz. of water and blend again.

When cheese is up to temperature, add pepper-pepper juice mixture into cheese and carefully blend mixture throughout the cheese. The final consistency of the cheese, when warmed to 145° to 160°F. should be such that when a teaspoon is dipped into it and removed, the cheese should drain rapidly, leaving only a thin film on the spoon. Cheese is now ready to insert into Nacho Cheese Warmer. More or less Jalapeno peppers and pepper juice may be used to suit taste.

NOTE: If cheese is to be pumped, it must be thinned enough so that the cheese does not clog the pump.