

IntelliShot 2.0
REFRIGERATED DAIRY DISPENSER
MODELS AC220-V2 &
AC110-V2

TABLE OF CONTENTS

INTRODUCTION	7	SOFTWARE FEATURES	27
Main Components	7	Settings	27
Specifications	9	Calibration	27
Legend	9	Refrigeration	30
RECEIVING THE DISPENSER	10	Products	32
Inspect for Damage	10	Network Settings	34
Registering the Dispenser's Warranty	10	Drink Counts	35
SETTING UP THE DISPENSER	11	Recipe	36
Where to Place the Dispenser	11	User Options	38
Safety Precautions	11	System Settings	39
Power Requirements	12	CLEANING THE DISPENSER	44
Tools Needed for Setup and Maintenance	12	Recommended Cleaning Schedule	44
Installing the Cup Guide	12	Cleaning Instructions	44
Installing the Catch Tray	12	Exterior and Button Panel	44
Turning on the Dispenser	12	Cup Guide	45
Setting the Language	13	Catch Tray	45
Cleaning the Dispenser	13	Dairy Bag Stopper	45
OPERATING THE DISPENSER	14	Product Case, Product Case Insert, and Product Compartment	46
Button Panel	14	Door Gasket	46
Notifications	16	Valve Assembly	46
Loading Dairy Product	19	Condenser	47
Preparing the Dispenser and Product	19	TROUBLESHOOTING	49
Loading Product into the Product Case	19	SERVICE AND WARRANTY	51
Loading the Product Case into the Dispenser	22	USA AND CANADA WARRANTY	53
Dispensing Product	24		
Removing an Empty Dairy Bag	25		
Using the Dairy Bag Stopper to Remove a Partially Filled Dairy Bag	25		

LIST OF FIGURES

Figure 1: Main exterior components of model AC220-V2	7
Figure 2: Main interior components of model AC220-V2	8
Figure 3: Main exterior components of model AC110-V2	8
Figure 4: Two product dispenser button panel	14
Figure 5: One product dispenser button panel	14
Figure 6: Display in normal operating mode	15
Figure 7: SureShot symbol	16
Figure 8: Temperature high indicator	16
Figure 9: Button panel lock indicator	17
Figure 10: Door open indicator	17
Figure 11: Product low indicator	17
Figure 12: Calibration countdown	18
Figure 13: Calibration required notification	18
Figure 14: Calibration pop-up alert	18
Figure 15: Lower 10-liter dairy bag into product case	19
Figure 16: Product case with insert and 5-liter dairy bag	20
Figure 17: Product case with dairy bag installed	20
Figure 18: Slide bag corner into product case slot	21
Figure 19: Slide 5-liter bag corners into product case slots	21
Figure 20: Top ring of bag fitment must be resting on product case floor	21
Figure 21: Removing the valve insert	22
Figure 22: Correct tube placement in valve opening	22
Figure 23: Reinstall the valve insert	23
Figure 24: Cut the tube	23
Figure 25: Confirm full bag was loaded	23
Figure 26: Select left navigation button to view Partial Bag screen	24
Figure 27: Locate dairy bag fitment hole and position stopper over fitment hole	25
Figure 28: Shorten stopper and lock stopper into place	26
Figure 29: Confirm stopper is installed correctly	26
Figure 30: Default settings page	27
Figure 31: Calibration icon	27
Figure 32: Calibration, first page	28
Figure 33: Select product to calibrate	28
Figure 34: First calibration test expected weight	29
Figure 35: Second calibration test expected weight	29
Figure 36: Calibration of 18% Cream complete confirmation	30
Figure 37: Refrigeration icon	30
Figure 38: Refrigeration page	30
Figure 39: Refrigeration setting adjustment bar	31
Figure 40: Refrigeration temperature display calibration saved	32
Figure 41: Products icon	33
Figure 42: Products page	33
Figure 43: Products bag type page	33
Figure 44: Product changed confirmation	34

Figure 45: Network settings icon	34
Figure 46: Network page	34
Figure 47: Drink counts icon	35
Figure 48: Drink counts page	35
Figure 49: Drink counts by shot quantity	36
Figure 50: Drink counts by beverage type, shot quantity and product/cup size	36
Figure 51: Recipe icon	36
Figure 52: Recipe page	37
Figure 53: View the recipe	37
Figure 54: User options icon	38
Figure 55: User options page	38
Figure 56: System settings icon	39
Figure 57: System settings page	39
Figure 58: Setting the date and time	40
Figure 59: USB stick plugged into the USB port at the bottom of the door	41
Figure 60: Software updates selected	41
Figure 61: Factory defaults dialog box	42
Figure 62: Remove the plunger	47
Figure 63: Condenser	47
Figure 64: Product identification label	51

LIST OF TABLES

Table 1: Recommended cleaning schedule	44
--	----

INTRODUCTION

MAIN COMPONENTS

Familiarize yourself with the names and locations of the dairy dispenser components.

Note: Your dispenser may differ from the images shown here.

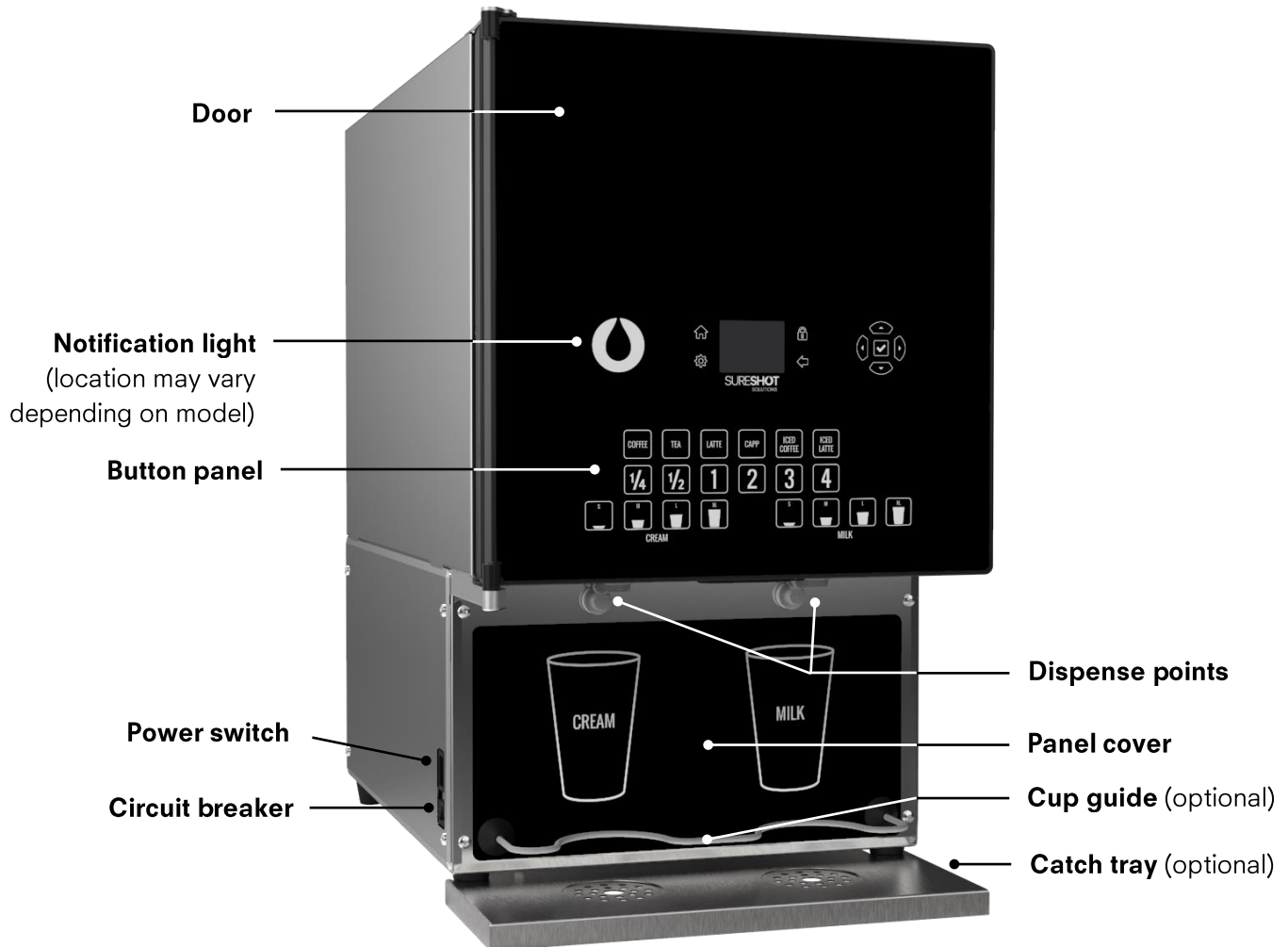

Figure 1: Main exterior components of model AC220-V2



Figure 2: Main interior components of model AC220-V2

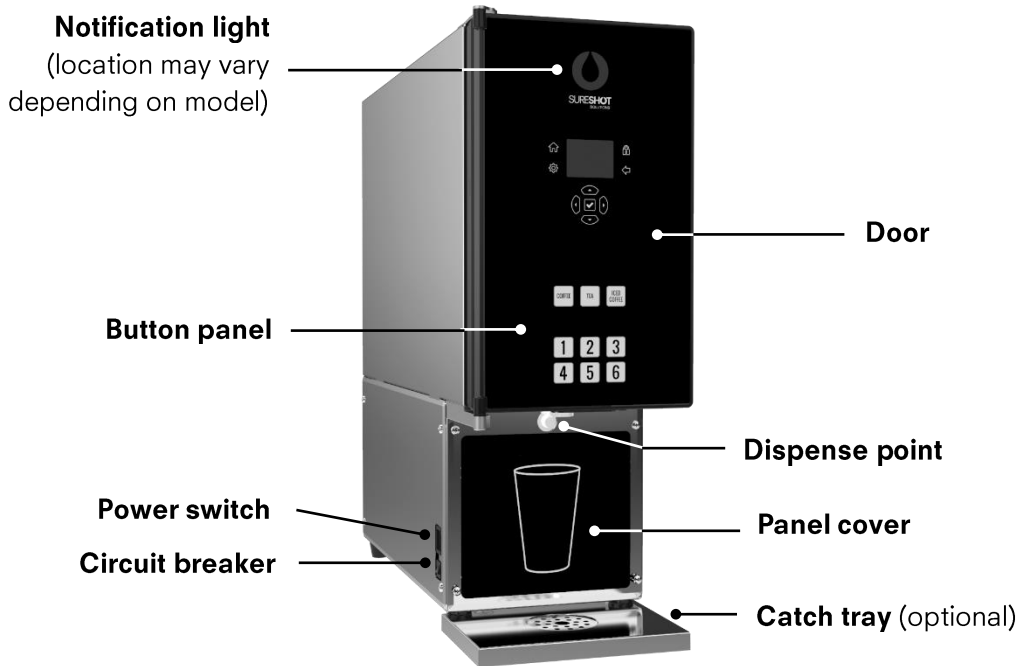





Figure 3: Main exterior components of model AC110-V2

SPECIFICATIONS

Model:	AC220-V2
Weight (empty):	65 lb. (29.5 kg)
Weight (full):	111 lb. (50.4 kg)
Dimensions (LxWxH):	25.25" x 15" x 25.5" (64.1 cm x 38.1 cm x 64.77 cm)
Power requirement:	As indicated on the product identification label, 120V AC, 60 Hz, 1.5A, 1ph
Capacity:	2 products x 10 L (2.5 gal.)
Certification:	 

Model:	AC110-V2
Weight (empty):	45 lb. (20.4 kg)
Weight (full):	68 lb. (30.8 kg)
Dimensions (LxWxH):	25.25" x 9" x 25.5" (64.1 cm x 22.86 cm x 64.77 cm)
Power requirement:	As indicated on the product identification label, 120V AC, 60 Hz, 1.5A, 1ph
Capacity:	1 product x 10 L (2.5 gal.) or 1 product x 5 L (1.3 gal.)
Certification:	 

LEGEND



Note icon

Used for explanations and reminders.



Tip icon

Used for information that will help the dispenser perform better.



Caution icon

Used for actions or functions that could cause damage to the dispenser or to users.

RECEIVING THE DISPENSER

INSPECT FOR DAMAGE

Do not accept shipment if damage is extensive. Always note damage in detail with the carrier whether shipment is accepted or refused as proof for damage claims.

If damage is found after accepting shipment:

1. Immediately contact A.C. Dispensing Equipment Inc. (SureShot Solutions®) at 888 777-9990 (USA & Canada) or +1 902 865 9602 for a Return Material Authorization (RMA) number. No returns will be accepted without prior approval.
2. A.C. Dispensing Equipment Inc. (SureShot Solutions) will then contact the shipping company to retrieve and return the damaged goods to our facility.
3. Hold damaged goods with the packing materials until the shipping company returns to make an inspection and pick up the damaged goods.

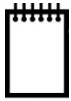

A.C. Dispensing Equipment Inc. (SureShot Solutions®) is **not** responsible for damage, delay or loss that may occur during shipping if the customer chooses to use a preferred carrier or freight forwarder.

REGISTERING THE DISPENSER'S WARRANTY

You must register your dispenser's warranty within 60 days of purchase.

Register online



sureshotsolutions.com/r/wreg

Register by phone



888 777-9990 (USA & Canada)
+1 902 865 9602

Prior to registering your warranty, note the model and serial numbers that are located on the product identification label on your dispenser. For more information on where to find these numbers, please refer to the SERVICE AND WARRANTY section of this manual. You will need this information when registering your product warranty.

SETTING UP THE DISPENSER

WHERE TO PLACE THE DISPENSER



The dispenser must be placed on a horizontal surface for optimum performance and dispense accuracy.

Place the dispenser where it will best serve your operation at an appropriate usage and filling height so that users can operate the dispenser without obstructions. The surface must be strong enough to support the dispenser full of product.

Do not place the dispenser too close to a source of heat or moisture.

This dispenser is intended for indoor use only.

The ambient or room temperature range for dispenser operation is 50°F to 90°F (10°C to 32°C).

Do not block the vents at the back of the dispenser. The vents must be free and open to ensure proper operation of the cooling system and to prevent overheating and damage to the dispenser. Maintain a 1 in. (2.5 cm) air space on all sides of the dispenser.

Make sure the legs are tightened in place at the four corners on the bottom of the dispenser. Do not remove the legs from the dispenser or let the dispenser sit directly on the counter. The dispenser's refrigeration system requires adequate airflow under the dispenser for accurate temperature control.



Operating the dispenser without the legs installed automatically voids the warranty.

SAFETY PRECAUTIONS

Always follow these safety precautions. Failure to do so will void the warranty.

- Always plug the dispenser into an approved, grounded electrical outlet.
- Unplug the dispenser from its power source before servicing.
- Do not immerse the dispenser in water.
- This dispenser must not be cleaned using a water jet or installed in an area where a water jet may be used.
- This dispenser is not intended for use by persons (including children) with reduced physical, sensory, or mental capabilities, and is not intended for use by those with a lack of experience and knowledge unless they are supervised or given instruction concerning the use of the dispenser by a person responsible for their safety.
- Children should be supervised when in the vicinity of the dispenser to ensure that they do not play with it.
- Observe all safety precautions with this dispenser as you would with any electrical appliance.

POWER REQUIREMENTS

This dispenser requires a power source receptacle with specifications as indicated on the product identification label. For more information on this, please refer to the specifications listed within the INTRODUCTION section of this manual.

The power cord has a 3-prong attachment plug. This plug is designed to fit a receptacle with provisions for a grounding stud. The dispenser must be operated on grounded electrical wiring at all times. Failure to do so will void the warranty.

TOOLS NEEDED FOR SETUP AND MAINTENANCE

You will need these tools for setup and maintenance:

- Small (#2) Phillips screwdriver
- Scissors

INSTALLING THE CUP GUIDE

For models with a cup guide:

1. Insert the ends of the cup guide into the top of the keyhole openings located on each side of the front panel.
2. Push down on the cup guide to secure in place.

INSTALLING THE CATCH TRAY

For models with a catch tray, line up the catch tray cut-outs with the front legs of the dispenser and gently push into place around the legs to secure.

TURNING ON THE DISPENSER

All liquid refrigerant and compressor oil must be settled in the bottom of the compressor before turning it on. If you suspect that the dispenser was not kept upright, let it sit on a horizontal surface for 24 hours before turning it on.



Before turning on the dispenser, be sure to remove the clear plastic protective film from the door front.

Follow these steps to turn on the dispenser:

1. Plug the power cord into the receptacle at the back of the dispenser.
2. Plug the other end of the cord into a 3-prong, grounded electrical outlet.
3. Turn on the dispenser. The power switch is located on the lower left side of the dispenser. When the dispenser is turned on, you will hear the fan and see the display light up.

SETTING THE LANGUAGE

The default display language is English. For information on how to change the language, please refer to the instructions for language in the SOFTWARE FEATURES section of this manual. Not all dispensers offer multiple languages.

CLEANING THE DISPENSER

Before using the dispenser for the first time, it must be thoroughly cleaned and dried. The dispenser must be cleaned on a regular basis to keep it operating efficiently. For cleaning instructions, please refer to the CLEANING THE DISPENSER section of this manual.

OPERATING THE DISPENSER

BUTTON PANEL

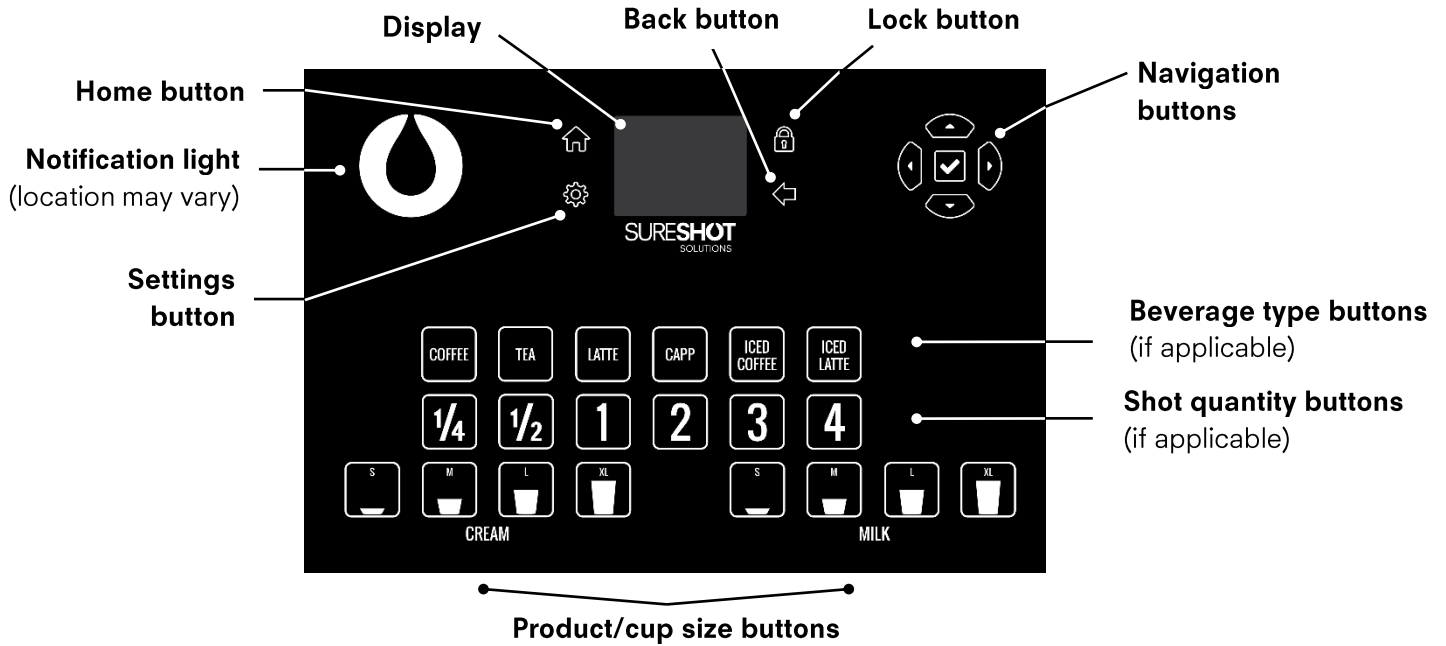

Figure 4: Two product dispenser button panel

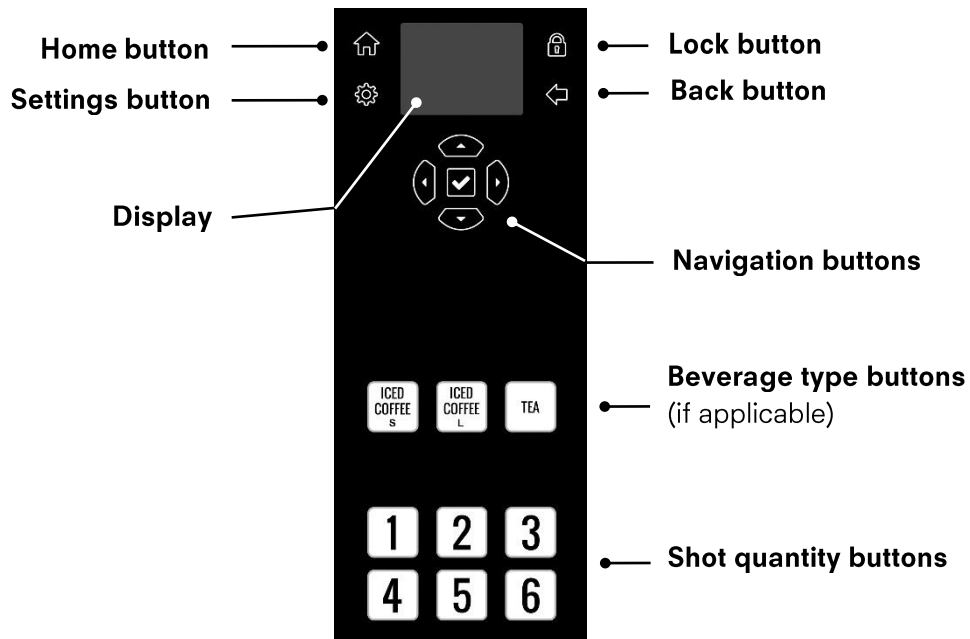

Figure 5: One product dispenser button panel

Note: Your button panel may differ from the images shown here.

Home button: Press this button to return to dispense mode from any page in settings.

Settings button: Please refer to the SOFTWARE FEATURES section of this manual for descriptions of the available functions within the dispenser's settings.

Display: The display shows the current operational status, the product compartment temperature, compressor status (a snowflake icon appears beside the temperature reading when the compressor is on), the product type, and the level of product available. For one product dispensers, only one product type is shown.

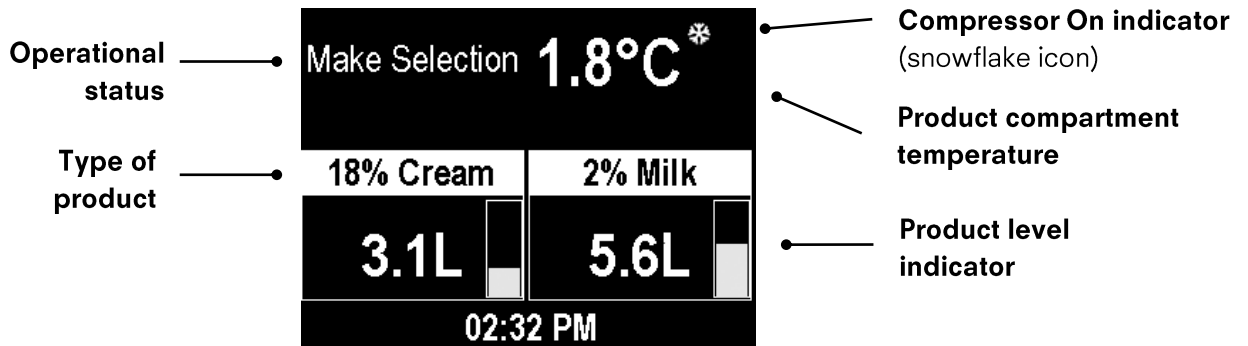

Figure 6: Display in normal operating mode

Lock button: To disable the button panel for cleaning, press and hold the lock button for one second until LOCKED appears on the display. To re-enable the button panel, press and hold this button again until the display returns to normal operating mode.

Back button: Press this button to go back to the previous screen.

Navigation buttons: Use the **arrow buttons** to navigate through the pages of the dispenser's settings. Use the **☑ button** to select OK.

The following buttons are used for preparing beverages. Your model may have one or more of these buttons:

Beverage type buttons: These buttons will change the amount of product (i.e., recipe) specific to the selected beverage type.

Shot quantity buttons: These buttons will dispense the required amount of product according to your recipe. Depending on your model, these buttons may decrease or increase the amount of product.

Product/cup size buttons: These buttons will change the dispense amounts based on cup size and will dispense the selected product.

Notification light: The SureShot symbol on the door will change color and/or flash if there is something that needs attention. Text will also appear in the display to notify you that something needs attention.

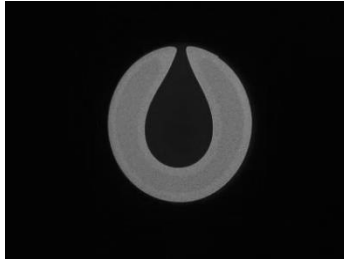

Figure 7: SureShot symbol

NOTIFICATIONS

If there is more than one notification, the SureShot symbol will flash in the color of the most critical issue, and the display will show each notification in its appropriate color. Available notifications vary depending on your model.

Flashing Red - critical

Temperature high or temperature low:

- When the dispenser's temperature is out of range, temperature adjustments may be required. Please refer to the TROUBLESHOOTING section of this manual to better understand what might be causing an out of range temperature.

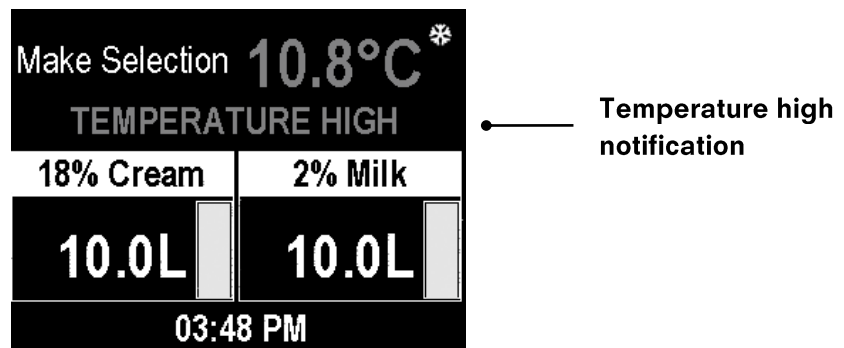

Figure 8: Temperature high indicator

Solid Yellow – non-critical

Locked:

- Button panel is locked for cleaning. All buttons, apart from the lock button, are disabled.

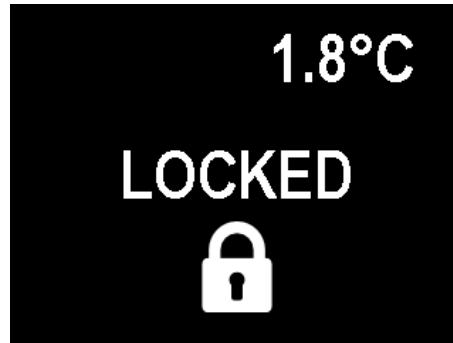

Figure 9: Button panel lock indicator

Flashing Yellow – non-critical

Dispenser door open:

- When the door is open, all dispensing buttons are locked to prevent accidental dispensing of product.

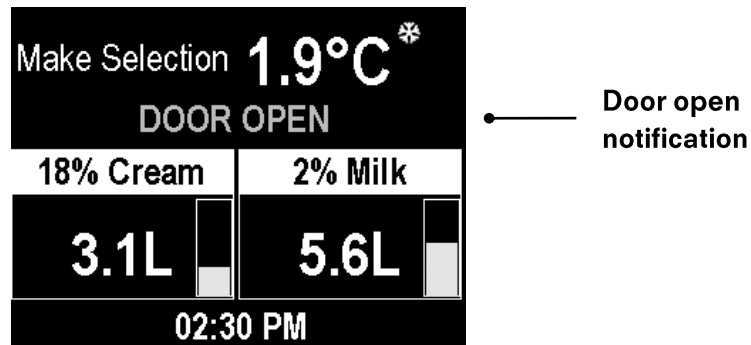

Figure 10: Door open indicator

Product low:

- The product level for one or more product types is considered low when less than 500ml (0.5 litres) of product remains.

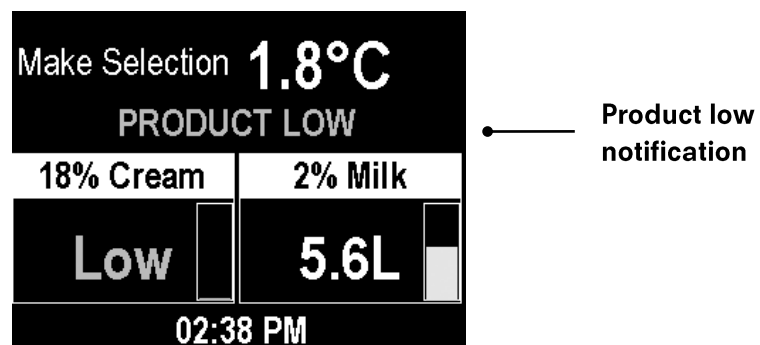

Figure 11: Product low indicator

Calibration Notification:

- For models with the calibration notification feature, a countdown to the next scheduled calibration is displayed.

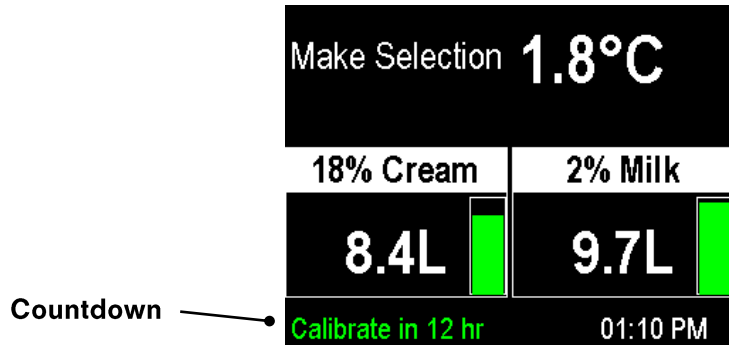

Figure 12: Calibration countdown

- Flashing yellow begins when the countdown has reached zero. The display will now show *Calibration Required*. A pop-up alert will periodically appear until the product is calibrated. Select the **button** to dismiss the pop-up alert.
- For information on how to calibrate, please refer to the instructions for calibration in the SOFTWARE FEATURES section of this manual.

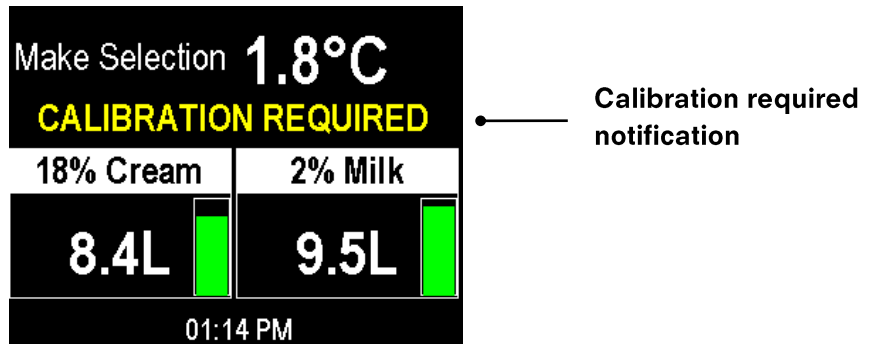

Figure 13: Calibration required notification

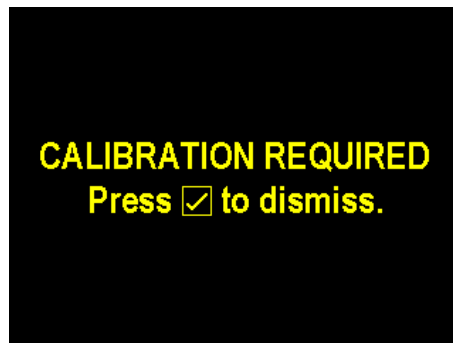

Figure 14: Calibration pop-up alert

Solid Green

Normal operation:

- There are no notifications (Figure 6).

LOADING DAIRY PRODUCT

Preparing the Dispenser and Product

1. Clean and dry the dispenser and all of its components.
2. Make sure product is pre-chilled to a temperature between 34°F and 40°F (1.1°C and 4.4°C) before loading it into the dispenser.
3. Plug in and turn on the dispenser.
4. Allow the dispenser to run empty for approximately 20 minutes to reach operating temperature before loading product into the dispenser.
5. Wash or sanitize your hands or wear clean gloves to load the product.



The dispenser must be on and cold before loading product.

Loading Product into the Product Case

This dispenser delivers dairy product from a sanitary, pre-filled dairy bag with an attached tube. Dairy bags are loaded into a product case.

1. Open dispenser door and remove the product case.
2. Holding top corners, lower a pre-filled dairy bag into the product case with tube positioned near the bottom, front opening of the product case.

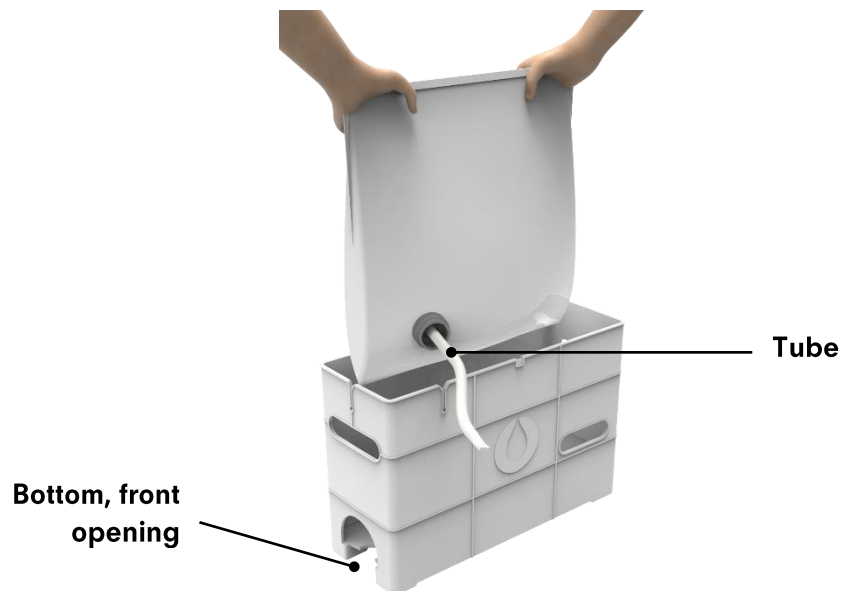

Figure 15: Lower 10-liter dairy bag into product case

3. If using a 5-liter dairy bag, install the product case insert prior to placing a dairy bag into the product case.

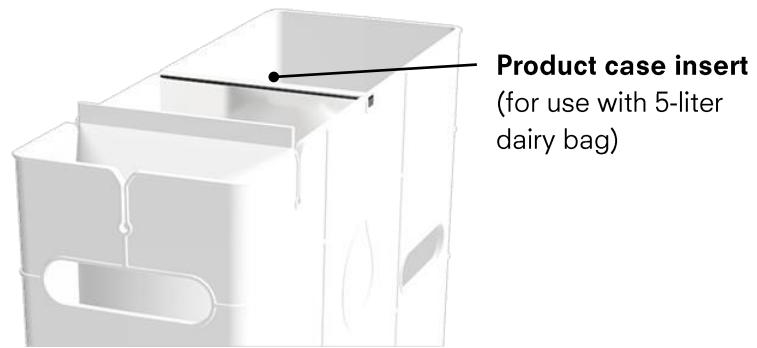

Figure 16: Product case with insert and 5-liter dairy bag

4. Adjust the bag to remove as many wrinkles as possible which will maximize product flow and emptying.
5. Adjust the bag to ensure the bag fitment and tube naturally exit the bottom, front opening of the product case.

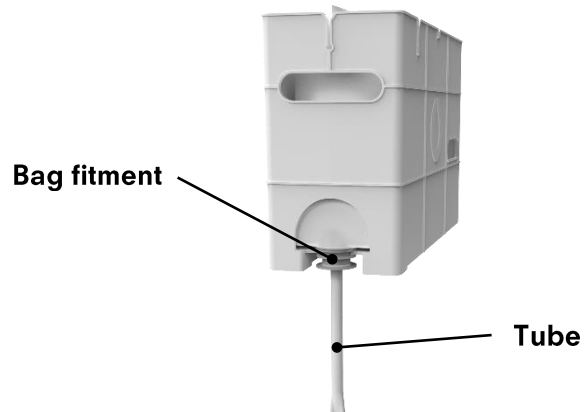

Figure 17: Product case with dairy bag installed



Do not adjust the bag by pulling on the fitment and tube as it may loosen and cause the bag to leak.

- Slide the top corner of the bag down into the slot located on the front of the product case.

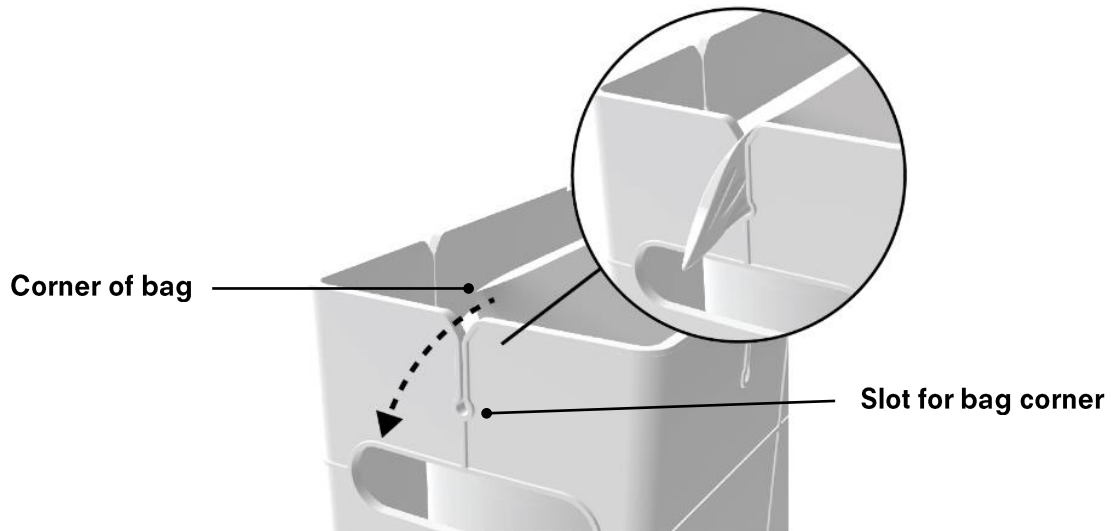

Figure 18: Slide bag corner into product case slot

If using a 5-liter dairy bag, slide corners of the bag down into the slots located on each side of the product case.

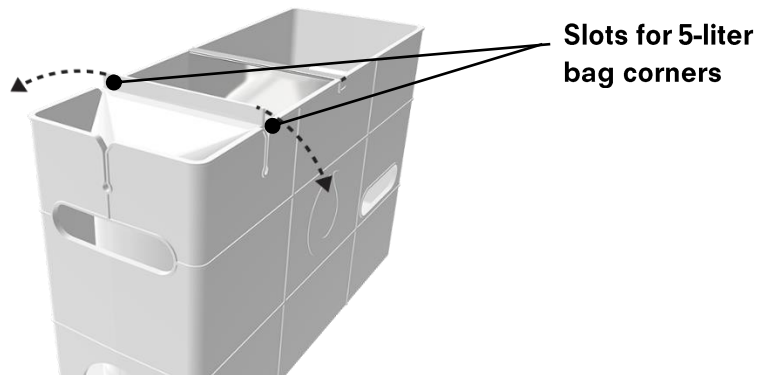

Figure 19: Slide 5-liter bag corners into product case slots

- Locate the top ring on the fitment (i.e., the ring closest to the bag). Slide the top ring of the fitment into the product case opening so that it is resting on the product case floor. Do not use the lower ring as dispense accuracy will be affected.



Figure 20: Top ring of bag fitment must be resting on product case floor

Loading the Product Case into the Dispenser

With the dispenser door closed, the correct product(s) will be shown on the display (Figure 6). For dispensers with more than one product, it is crucial to identify the correct location within the product compartment for each product according to the software (e.g., 18% cream installed above the left valve). To change the default product(s) or a product location refer to the instructions for Products in the SOFTWARE FEATURES section of this manual.

1. With the dispenser door open, push the plunger in and pull down on the valve insert to remove it from the valve assembly. Release the plunger.

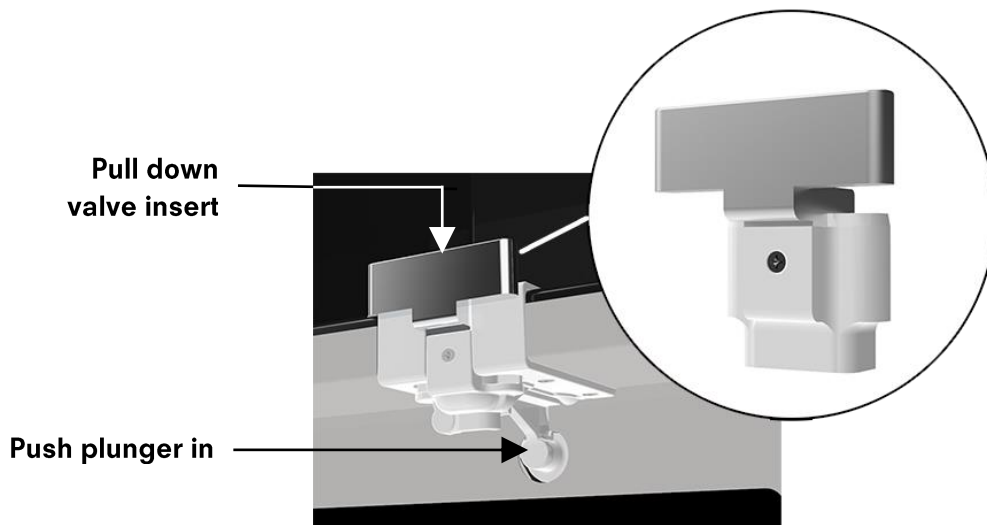

Figure 21: Removing the valve insert



The valve insert is magnetic and can be attached to the front panel for safekeeping.

2. Insert the product case into the product compartment with the tube facing out.
3. Remove and discard the plastic covering on the tube, if present.
4. Center the tube in the valve opening. Do not pull or stretch the tube. It should not be twisted, kinked, or pinched.

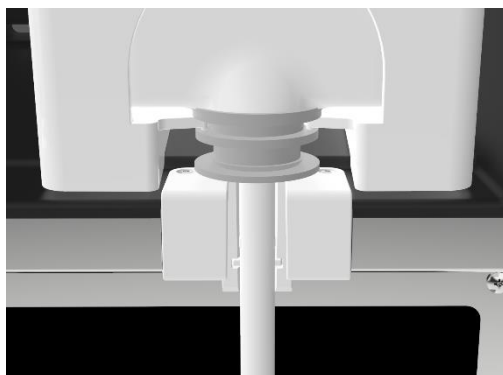

Figure 22: Correct tube placement in valve opening

5. Push in the plunger and reinstall the valve insert back up into the valve assembly. Release the plunger.

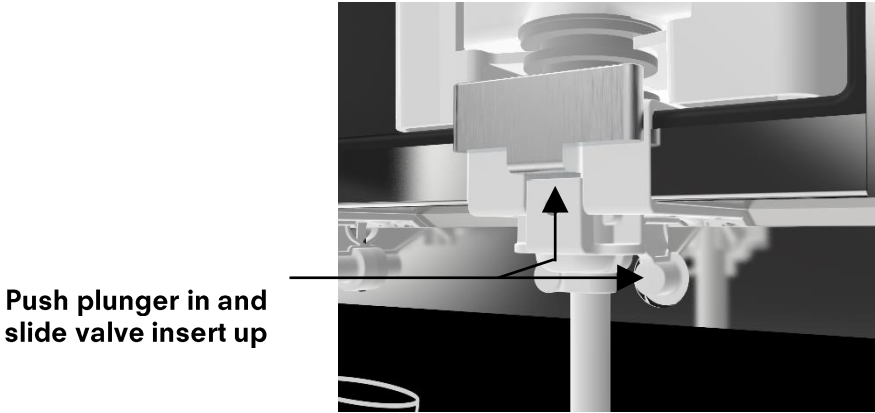

Figure 23: Reinstall the valve insert

6. Use sanitized, sharp scissors to carefully cut the tube level with the bottom of the valve. Discard the cut portion of the tube.



Before cutting the tube, clear the tube of product to prevent spraying. Fold up the tube, pinching it just below the valve, and push in the plunger a couple of times to move product into the bag.

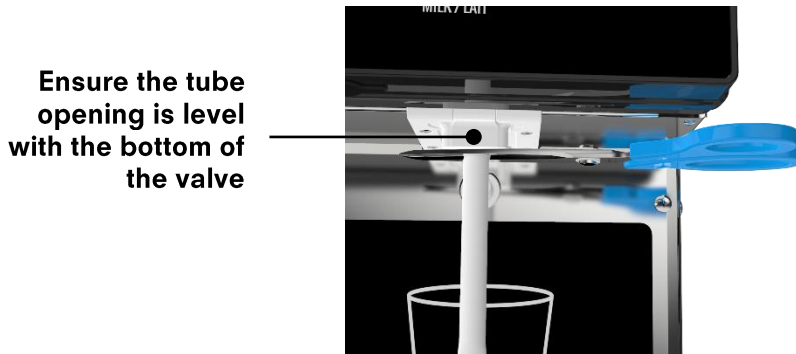

Figure 24: Cut the tube

7. Close the dispenser door.
8. If a full bag was loaded, select the **button, or any dispense button** to confirm. If a partially filled bag was loaded, proceed to step 9.

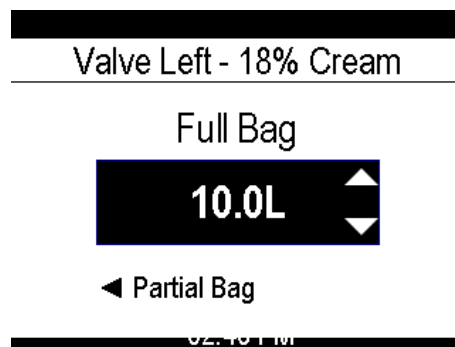

Figure 25: Confirm full bag was loaded

9. After loading a partially filled bag, select the **left navigation button**.

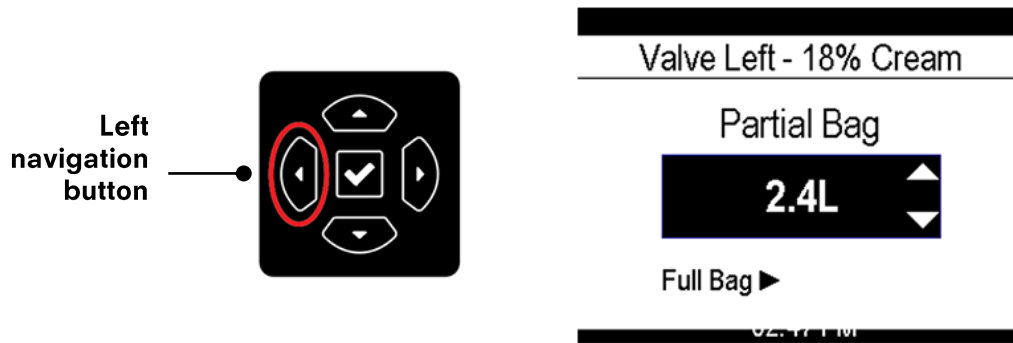

Figure 26: Select left navigation button to view `Partial Bag` screen

If the partially filled bag that was last removed is reloaded in the same location (i.e., removed and reloaded above the left valve), the displayed volume (e.g., 2.4L) will match the amount of product remaining in the bag. If this is correct, select the **button, or any dispense button** to confirm.

If the partially filled bag is not the last bag removed or is being loaded in a different location within the product compartment (i.e., removed from left valve and reloading above right valve), use the **up or down navigation buttons** to adjust the displayed volume to match the amount of product remaining in the bag. Adjustments are made in 0.1 L (i.e., 100 ml) increments. Press the **button** to confirm.



Before removing a partially filled dairy bag from the dispenser, refer to the display in normal operating mode (Figure 6) and make note of the product volume for that bag (e.g., 2.4L). This information is required when reloading a partially filled bag for accurate dispense amounts. For models with a dairy bag stopper refer to the instructions for Using the Dairy Bag Stopper to Remove a Partially Filled Dairy Bag.

DISPENSING PRODUCT

One touch dispenser: Pressing any button will result in product dispensing.

Examples:

- To prepare a medium hot coffee or tea with two shots of product, press the 2-shot quantity button.
- To prepare a small beverage type (e.g., iced coffee), press the small iced coffee beverage type button.

Multi-touch dispenser: In most cases, more than one button press is required to dispense product. Only one button press is required if a beverage type (i.e., coffee) has been set as the default.

Examples:

- To prepare a medium tea with half of a shot of milk, press Tea + ½ + the medium product/cup size button under Milk.
- To prepare a large coffee with two shots of cream when coffee is the default beverage type, press 2 + the large product/cup size button under Cream.
- To prepare a small coffee with one shot of milk when coffee is the default beverage type and 1 is the default shot quantity, press the small product/cup size button under Milk.



For multi-touch dispensers, the cup must be placed under the appropriate dispense point.

REMOVING AN EMPTY DAIRY BAG

1. Place a container under the dispense point to catch any residual product that may drain when the valve insert is removed.
2. Open the dispenser door.
3. Push in the plunger.
4. Pull the valve insert down and out of the valve assembly. The valve insert is magnetic and can be attached to the front panel for safekeeping.
5. Allow any residual product to drain.
6. Pinch the tube to reduce drips.
7. Remove the product case with the empty dairy bag.
8. Discard the empty dairy bag.
9. Clean the product case before loading a new dairy bag.

USING THE DAIRY BAG STOPPER TO REMOVE A PARTIALLY FILLED DAIRY BAG

For models with a dairy bag stopper, insert the stopper before removing a partially filled dairy bag from the dispenser to prevent spills.

1. With your finger, locate the hole on the top of the bag fitment and position the stopper over the hole.

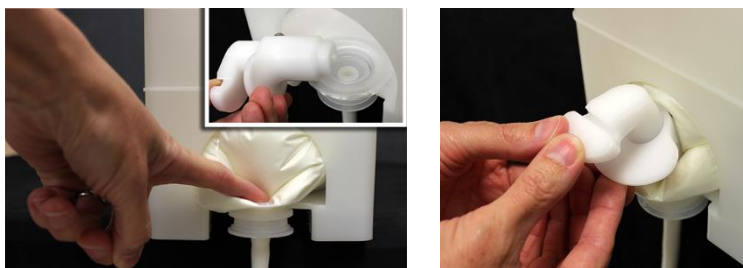

Figure 27: Locate dairy bag fitment hole and position stopper over fitment hole



The dairy bag must be correctly loaded into the product case otherwise the bag stopper will not work properly. Please refer to the loading product into the product case instructions within the OPERATING THE DISPENSER section of this manual.

2. Once in place, push down the top of the stopper to shorten its length so that it will fit into the product case opening. Line up the groove on the top of the stopper with the edge of the product case opening and ensure it locks into place. It needs to click in place and be straight (horizontal) to avoid leaking.

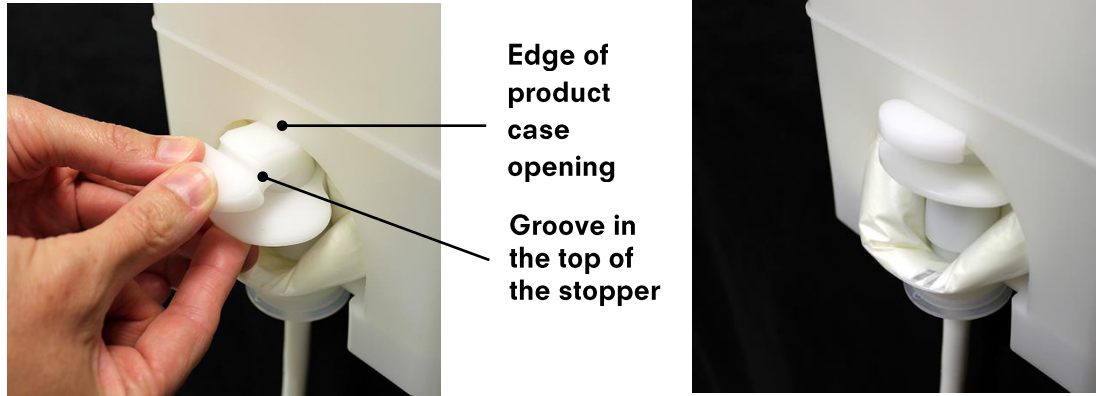

Figure 28: Shorten stopper and lock stopper into place

3. Confirm the stopper is installed correctly by hooking your finger around the back of the stopper and gently pulling forward to ensure the bottom of the stopper is over the bag fitment hole and that it is straight.



Figure 29: Confirm stopper is installed correctly

4. Refer to the display in normal operating mode (Figure 6) and make note of the product volume of the bag to be removed.
5. Place an empty cup under the dispense point to catch any dairy that may still be in the tube.
6. Remove the valve insert and product case.



If reloading the same product case with the partially filled dairy bag, reinstall the valve insert before removing the bag stopper.

SOFTWARE FEATURES

SETTINGS

There are several features available within the dispenser's settings for both restaurant-level and service-level procedures. This section describes the available restaurant-level features: Calibration, Refrigeration, Products, Network Settings, Drink Counts, Recipe, User Options, and System Settings.

To access the settings page, press and hold the **settings button** for one second. Use the **navigation buttons** to move around the settings pages.

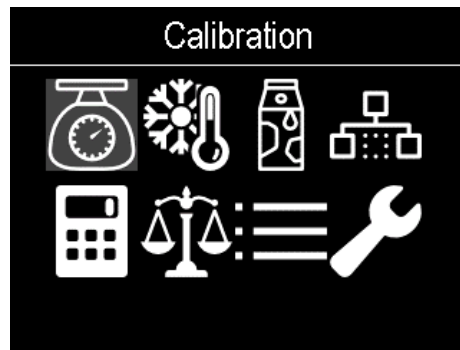
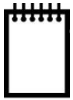

Figure 30: Default settings page



To return to the previous screen select the **back button** or press the **home button** to return to dispense mode. All changes must be saved by pressing the **button** or they will be lost.

Calibration

In some circumstances, the actual amount of dispensed product may be slightly different from the recipe amount. Select the calibration icon to correct inaccurate dispense amounts. You will need a digital scale and an empty cup for this procedure. For best results calibrate with a full or near full dairy bag.

1. Press and hold the **settings button** for one second to enter the settings page.
2. If not already highlighted, press the **right or left navigation button** repeatedly until the calibration icon is highlighted.



Figure 31: Calibration icon

3. Press the **☑ button**. The first page shows the current calibration values as percentages. For models with the calibration notification feature, a countdown to the next scheduled calibration will be displayed. Once the countdown reaches zero, a **Calibration Required** message will appear.

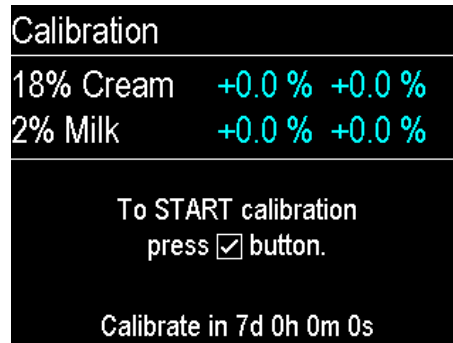

Countdown or calibration required message
(only for models with calibration notification feature)

Figure 32: Calibration, first page

4. Press the **☑ button** again to start the calibration procedure.
5. Select a product by pressing the **up or down navigation button** and then pressing the **☑ button**. For one product dispensers, skip this step. For models with calibration notification feature, a product highlighted in yellow indicates it needs to be calibrated.

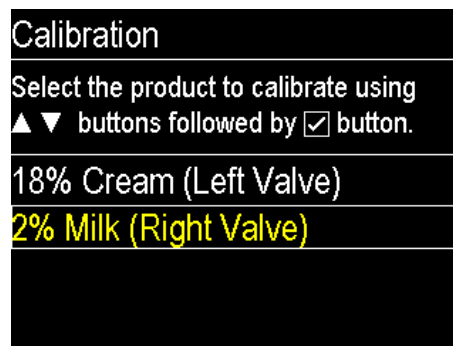

Product highlighted in yellow, indicates it needs to be calibrated
(only for models with calibration notification feature)

Figure 33: Select product to calibrate

6. Set a scale to grams.
7. Place an empty cup on the scale and zero/tare the scale.
8. Place the cup under the dispense point for the product you selected in step 5. For one product dispensers there is only one dispense point.

9. Press the **☑ button** to dispense product. The number displayed is the expected weight in grams of the first calibration test dispense. Please note, there are four test dispenses in total.

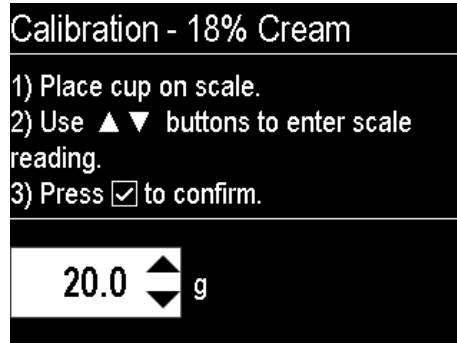

Figure 34: First calibration test expected weight

10. Place cup with the dispensed product onto the scale to check its weight.
11. Use the **up or down navigation button** to change the displayed number to match the actual weight shown on the scale display. Press the **☑ button** to confirm the amount.
12. Discard product from the cup. Place cup back on the scale and zero/tare the scale.
13. Place the cup back under the dispense point for the product you are calibrating.
14. Press the **☑ button** to dispense product. The number displayed is the expected weight in grams of the second calibration test dispense.

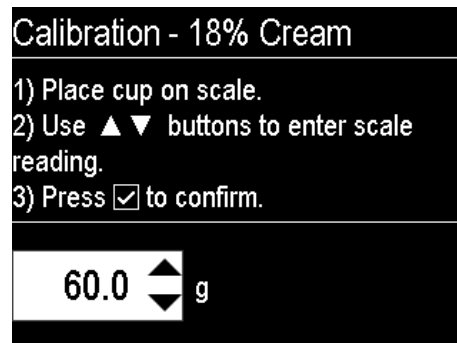

Figure 35: Second calibration test expected weight

15. Place cup with the dispensed product onto the scale to check its weight.
16. Use the **up or down navigation button** to change the displayed number to match the actual weight shown on the scale display. Press the **☑ button** to confirm the amount.
17. Repeat steps 12 to 16 two more times in order to complete the third and fourth test dispenses, then proceed to step 18.
18. Calibration is now complete for the chosen product.

19. To calibrate another product, select the **☑ button** or press the **home button** to exit.

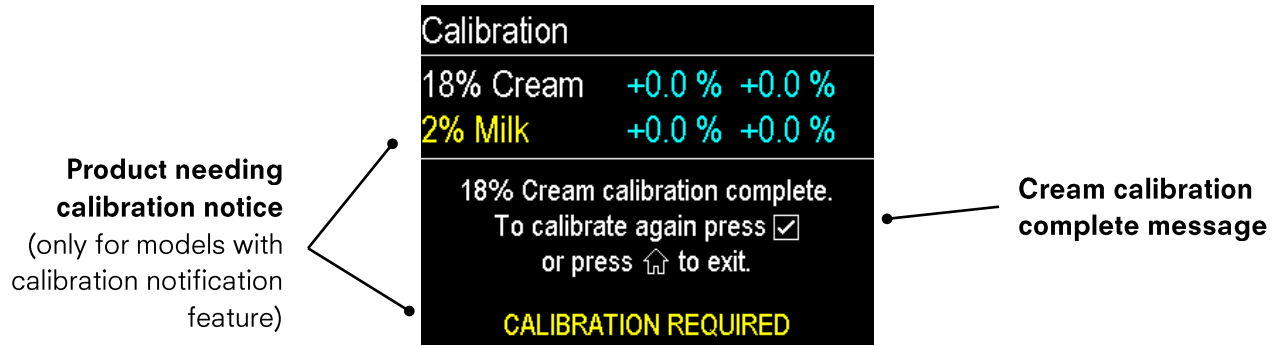

Figure 36: Calibration of 18% Cream complete confirmation

To return to the previous screen select the **back button**.

Refrigeration

Select the refrigeration icon to view the settings and control the refrigeration system and its changeable features.

View the Refrigeration Page

1. Press and hold the **settings button** for one second to enter the settings page.
2. Press the **left or right navigation buttons** repeatedly until the refrigeration icon is highlighted.

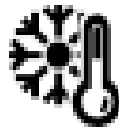

Figure 37: Refrigeration icon

3. Press the **☑ button**.

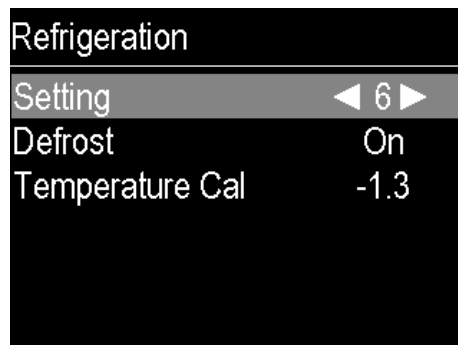

Figure 38: Refrigeration page

To return to the previous screen select the **back button** or press the **home button** to return to dispense mode.

Refrigeration Setting

The refrigeration setting ranges from 0 (off) to 12 (coldest). The factory default is 6. If necessary, the setting can be adjusted.

1. Press and hold the **settings button** for one second to enter the settings page.
2. Press the **left or right navigation button** repeatedly until the refrigeration icon is highlighted.
3. Press and hold the **settings button** again for one second.
4. Press the **up or down navigation button** until the `Setting` row is highlighted.
5. Press the **left or right navigation button** to access the adjustment bar.

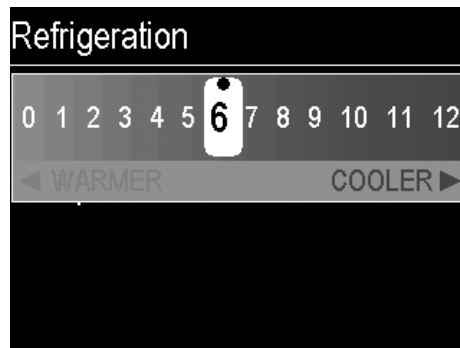

Figure 39: Refrigeration setting adjustment bar

6. Press the **left or right navigation button** to change the setting.
7. Press the **button** to save the new setting.

To return to the previous screen select the **back button** or press the **home button** to return to dispense mode.

Refrigeration Defrost

The defrost feature can be turned on or off.

1. Press and hold the **settings button** for one second to enter the settings page.
2. Press the **left or right navigation button** repeatedly until the refrigeration icon is highlighted.
3. Press and hold the **settings button** for one second.
4. Press the **up or down navigation button** until the `Defrost` row is highlighted.
5. Press the **left or right navigation button** to select `On` or `Off`.
6. Press the **button** to save the new setting.

To return to the previous screen select the **back button** or press the **home button** to return to dispense mode.

Temperature Display Calibration

If the temperature of the product inside the dispenser is different from the reading shown on the display, temperature calibration is required.

1. Calculate the value required to calibrate the temperature:
 - a. Dispense product into a cup. Use a thermometer to measure the temperature.
 - b. Actual product temperature minus the displayed temperature equals the required value.

Example 1: If the temperature of the product is 38°F and the temperature on the display reads 40°F, the value is -2 (i.e., 38°F – 40°F = -2).

Example 2: If the temperature of the product is 2°C and the temperature on the display reads 1.7°C, the value is 0.3 (i.e., 2°C – 1.7°C = 0.3).

2. Press and hold the **settings button** for one second to enter the settings page.
3. Press the **left or right navigation button** repeatedly until the refrigeration icon is highlighted.
4. Press and hold the **settings button** for one second.
5. Press the **up or down navigation button** until the Temperature Cal row is highlighted.

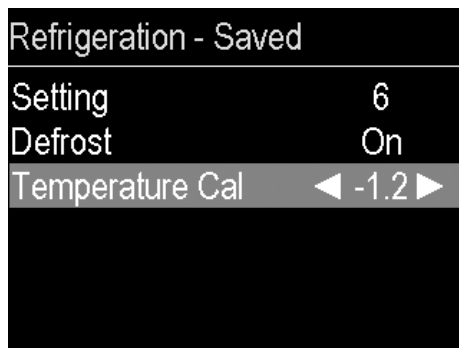

Figure 40: Refrigeration temperature display calibration saved

6. Press the **left or right navigation button** to adjust the value as required.
7. Press the **button** to save the new setting. The top title of the page will change to read Refrigeration - Saved.

To return to the previous screen select the **back button** or press the **home button** to return to dispense mode.

Products

Select the products icon to confirm or change the default product, bag type and its correct location within the product compartment.

1. Press and hold the **settings button** for one second to enter the settings page.

2. Press the **left or right navigation button** repeatedly until the products icon is highlighted.



Figure 41: Products icon

3. Press the **checkbox button** to view the default product and its location. Select the back button to return to the previous screen or press the home button to return to dispense mode. To change the default, press the **up or down navigation button** to highlight the product to be configured (left or right valve). For one product dispensers only one product is displayed.



Figure 42: Products page

4. Press the **checkbox button**. The display will show the current product and bag type.

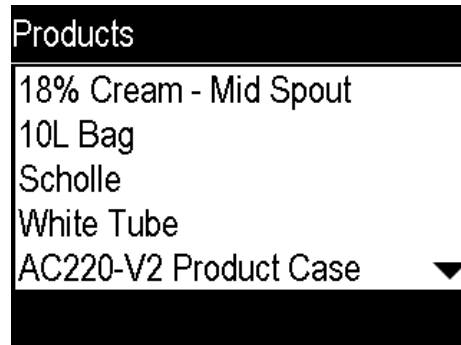

Figure 43: Products bag type page

5. Press the **up or down navigation button** repeatedly to scroll through the available product and bag type options. While scrolling, the text at the top of the display will show `Products - Changed`.

6. Press the **button** to save the new product and bag type. Text at the top of the display will show `Products - Saved`.



Figure 44: Product changed confirmation

To return to the previous screen select the **back button** or press the **home button** to return to dispense mode.

Network Settings

Select the network settings icon to connect the dispenser to a network and to display the settings.

1. Press and hold the **settings button** for one second to enter the settings page.
2. Press the **left or right navigation button** repeatedly until the network settings icon is highlighted.



Figure 45: Network settings icon

3. Press the **button**.

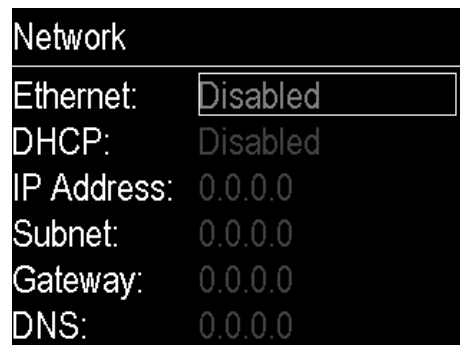

Figure 46: Network page

4. The two options for the Ethernet and DHCP settings are Enabled and Disabled. To change either setting:
 - a. Press the **up or down navigation button** to highlight the setting you want to change.
 - b. Press the **button** to change the setting to Enabled. Wait approximately 5 seconds for the display to change from Disabled to Enabled. Press the **button** again to change the setting back to Disabled.

When the Ethernet setting is disabled, the other settings are not available.

When DHCP is enabled, and your restaurant has a DHCP server, all network configurations will automatically be set (providing the dispenser is plugged into the network). Select Disabled if you do not have network connection or your IT administrator wants to manually enter the network configurations.

To return to the previous screen select the **back button** or press the **home button** to return to dispense mode.

Drink Counts

Select the drink counts icon to display the number of dispenses made for each shot quantity, product/cup size, and beverage type.

1. Press and hold the **settings button** for one second to enter the settings page.
2. Press the **left or right navigation button** repeatedly until the drink counts icon is highlighted.



Figure 47: Drink counts icon

3. Press the **button**. The screen displays the number of dispenses for each product.

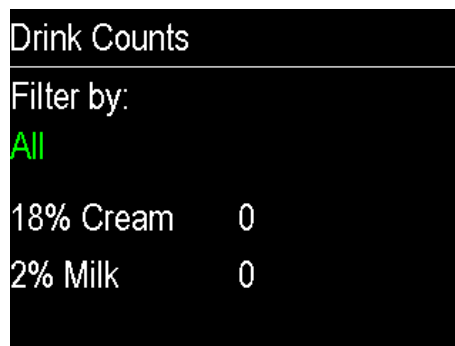

Figure 48: Drink counts page

- To see the number of dispenses for each shot quantity, select the **shot quantity buttons** one at a time.

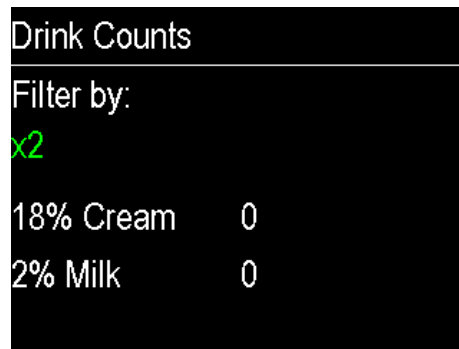

Figure 49: Drink counts by shot quantity

- To see the number of dispenses for a specific beverage, press a **beverage type button**, a **shot quantity button**, and a **product/cup size button**. Continue to select other variations to gather the required drink counts.

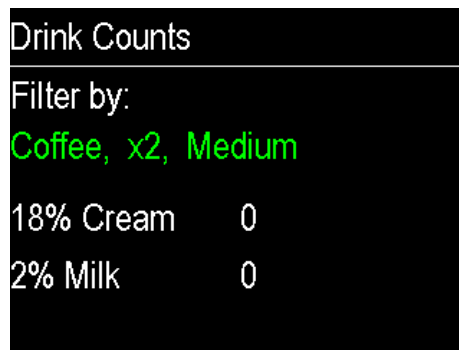

Figure 50: Drink counts by beverage type, shot quantity and product/cup size

To return to the previous screen select the **back button** or press the **home button** to return to dispense mode.

Recipe

Select the recipe icon to display dispense amounts for each product and to change the default amounts if necessary. Changes are made in 0.1 ml increments.

Check the Product Dispense Amounts

- Press and hold the **settings button** for one second to enter the settings page.
- Press the **left or right navigation button** repeatedly until the recipe icon is highlighted.



Figure 51: Recipe icon

3. Press the **☑ button**.

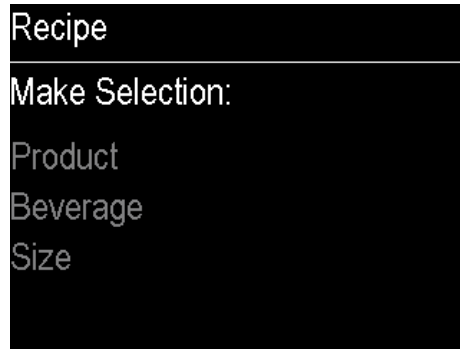

Figure 52: Recipe page

4. Select a **beverage type button** (if applicable) followed by a **product/cup size button** or a **shot quantity button**. The selection is displayed as well as the current dispense amount.

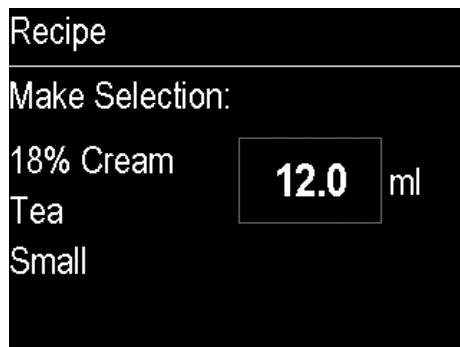

Figure 53: View the recipe

5. Continue to select other variations to verify dispense amounts. Press a button once to make a selection and press the same button again to deselect.

To return to the previous screen select the **back button** or press the **home button** to return to dispense mode.

To Adjust the Product Dispense Amounts

1. Press and hold the **settings button** for one second to enter the settings page.
2. Press the **left or right navigation button** repeatedly until the recipe icon is highlighted.
3. Press and hold the **settings button** again for one second.
4. Press a **beverage type button** (if applicable) followed by a **product/cup size button** or a **shot quantity button**.
5. Press the **up or down navigation button** to adjust the amount of product dispensed. The displayed dispense amount will change color as it is adjusted.
6. Press the **☑ button** to save the new dispense amount.
7. Repeat steps 1-6 to complete additional dispense amount adjustments if required.

To return to the previous screen select the **back button** or press the **home button** to return to dispense mode.

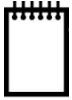

If a selection is made for which there is no recipe, the bottom of the display will show `Invalid Selection`. A beverage type may not be offered in all sizes or may only be prepared with one dairy product (e.g., a latte beverage type that is only offered with milk, will not have a recipe amount for cream).

User Options

Select the user options icon to access additional default settings (i.e., Language, Display Units, and Temperature Units).

1. Press and hold the **settings button** for one second to enter the settings page.
2. Press the **left or right navigation button** repeatedly until the user options icon is highlighted.



Figure 54: User options icon

3. Press the **button**.

User Options	
Language	◀English▶
Recipe Region	Canada
Door Sensor	On
Display Units	Liters
Temperature Units	F
Drink Counts	Reset

Figure 55: User options page

4. Use the **up or down navigation button** to highlight the setting you'd like to change (e.g., language).
5. Use the **left or right navigation button** to scroll through the available options within the selected setting.
6. Select the **button** to save the change.
7. Press the **back button** to return to the previous screen or press the **home button** to return to dispense mode.



Some settings within the user options menu may not be available on all models.

Language

Multiple languages may be available (e.g., English or French).

Recipe Region

If applicable, more than one region may be available (e.g., Canada or USA)

Door Sensor

Use this function if the yellow door open indicator will not turn off when the door is closed. The dispenser will not dispense when the door open indicator is on.

Display Units

Display the volume in either gallons or liters.

Temperature Units

Change the temperature display to Fahrenheit (F) or Celsius (C).

Drink Counts – Reset

To reset the drink counts to zero:

1. Drink Counts row is highlighted.
2. Press the **left or right navigation button**. A dialog box opens.
3. Press the **left or right navigation button** to select Yes or No.
4. With Yes selected, press the **button** and the drink counts will be reset to zero.

System Settings

Select the system settings icon to make changes to the dispenser's software.

Accessing System Settings

1. Press and hold the **settings button** for one second to enter the settings page.
2. Press the **left or right navigation button** repeatedly until the system settings icon is highlighted.



Figure 56: System settings icon

3. Press the **button**.

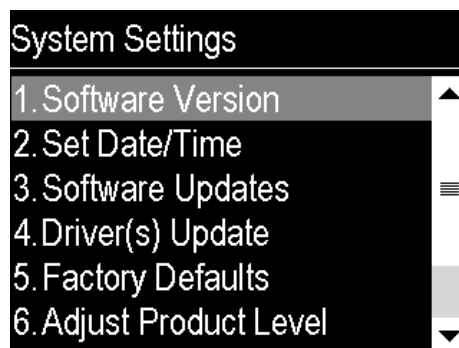

Figure 57: System settings page

Follow the instructions below to access the system settings options. When you are finished, press the **back button** to return to the previous screen or press the **home button** to return to dispense mode.

Software Version

1. Refer to previous instructions for **Accessing System Settings**.
2. Press the **up or down navigation button** repeatedly until `Software Version` is highlighted.
3. Press the **button**. The first software version page is displayed.
4. Press the **left or right navigation button** to scroll through each page.

To return to the previous screen select the **back button** or press the **home button** to return to dispense mode.

Set Date/Time

1. Refer to previous instructions for **Accessing System Settings**.
2. Press the **up or down navigation button** repeatedly until `Set Date/Time` is highlighted.
3. Press the **button**. The 12 hour/24 hour field is highlighted.

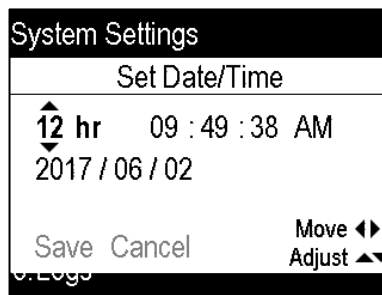

Figure 58: Setting the date and time

4. Press the **up or down navigation button** until the correct time mode is set (i.e., 12-hour clock or 24-hour clock).
5. Press the **left or right navigation button** to move between fields and the **up or down navigation button** to adjust values. Repeat these steps until you have the correct time and date set.
6. Press the **left or right navigation button** to select `Save` or `Cancel`.
7. Press the **button**. If you selected `Save` in the previous step, the display will show `System Settings - Saved`.

To return to the previous screen select the **back button** or press the **home button** to return to dispense mode.

Software Updates

1. Refer to previous instructions for **Accessing System Settings**.
2. Remove the rubber cover protecting the USB port on the bottom of the door and plug in the USB stick with the updated software.

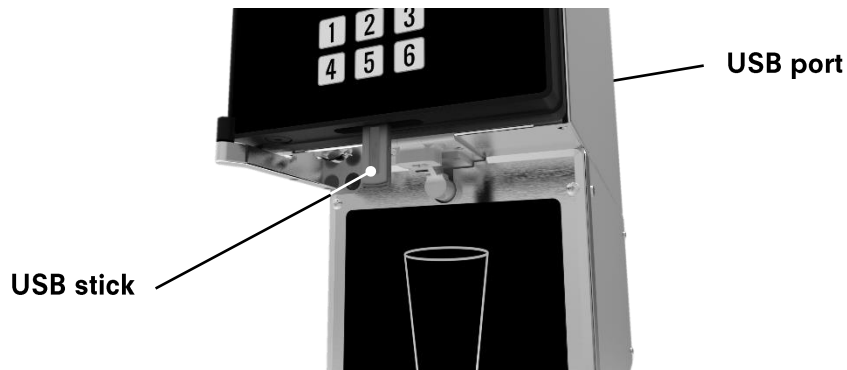

Figure 59: USB stick plugged into the USB port at the bottom of the door

3. Press the **up or down navigation button** repeatedly until `Software Updates` is highlighted.

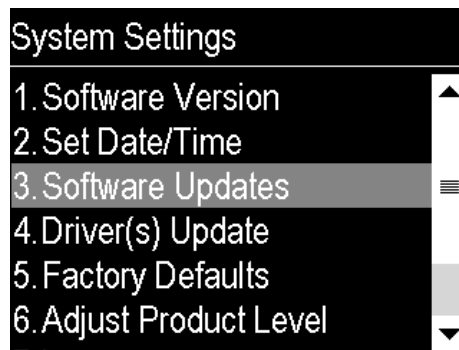

Figure 60: Software updates selected

4. Press the **✓ button**.
5. The display will show `Searching...` In approximately 10 seconds or less, the display will change and list one or more file names.
6. If more than one file name is listed, press the **up or down navigation button** to scroll through the options until you get to the correct file type (`.UPD`). For example, `SURESHOT.UPD` is an appropriate file type for updates. Press the **✓ button**.
7. While the file is being copied to the dispenser, the file name will slowly highlight in green from left to right indicating the copy progress. This can take approximately one minute.
8. When the screen goes white, the file has been successfully copied and the new software is now being installed. This can take approximately one minute.
9. When the installation of the new software is complete, the display will return to dispense mode.
10. Remove the USB stick and replace the rubber cover protecting the USB port.



Driver(s) Update

The Driver(s) Update option should only be used under the supervision of a service technician. This function will start an update that will reprogram the solenoid(s) and refrigeration firmware.

1. Refer to previous instructions for **Accessing System Settings**.
2. Press the **up or down navigation button** repeatedly until `Driver (s) Update` is highlighted.
3. Press the **button**. A dialog box opens.
4. Press the **left or right navigation button** to select `Yes` or `No`.
5. With `Yes` selected, press the **button**. The update will commence, a progress bar will open and you will see how the update is progressing. The update will take a few minutes. Once complete, you will see a list of the items that have been updated (i.e., `Solenoid (Left)`, `Solenoid (Right)`, or `Refrigeration`) along with the word `Passed` or `Failed` next to each.

To return to the previous screen select the **back button** or press the **home button** to return to dispense mode.



Factory Defaults

Factory default settings will be restored. Changes made by the user to calibration, network, refrigeration, and the clock settings are saved and will not return to a factory default setting.

1. Refer to previous instructions for **Accessing System Settings**.
2. Press the **up or down navigation button** repeatedly until `Factory Defaults` is highlighted.
3. Press the **button**. A dialog box opens.

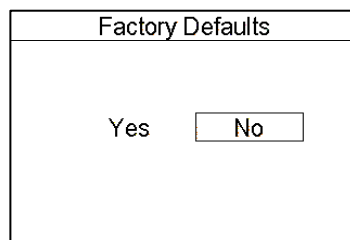

Figure 61: Factory defaults dialog box

4. Press the **left or right navigation button** to select `Yes` or `No`. Selecting `Yes` returns the dispenser's settings to the factory defaults.
5. With `Yes` selected, press the **button**. The display will show `System Settings - Saved`.

To return to the previous screen select the **back button** or press the **home button** to return to dispense mode.



Adjust Displayed Product Level

If a partially filled bag has been loaded, manually adjust the displayed product level. It is imperative that the dispenser's software is updated with accurate product level information upon loading a dairy bag. Inaccurate product level information can affect dispense accuracy.

1. Refer to previous instructions for **Accessing System Settings**.
2. Press the **up or down navigation button** repeatedly until `Adjust Product Level` is highlighted.
3. Press the **button**. A dialog box opens showing the product level.
4. Press the **up or down navigation button** repeatedly until the display shows the accurate volume of product in the bag.
5. Press the **button** to confirm. For dispensers with more than one product, another dialog box will open for the other product.
6. Repeat steps 4 and 5 to adjust the display level for another product. If a displayed product level is correct for a particular product, press the **button** to confirm and the next product level dialog box will open.

To return to the previous screen select the **back button** or press the **home button** to return to dispense mode.

Logs

This feature is only to be used under the guidance of a SureShot Solutions representative. The logs feature is used to export data logged by the dispenser.

Refrigeration Defaults

This feature is only to be used under the guidance of a SureShot Solutions representative. `Refrigeration Defaults` is used to restore the factory defaults on the refrigeration system. Changes made by the user to the refrigeration system settings are saved and will not be restored with a `Factory Defaults` (Figure 61).

CLEANING THE DISPENSER



- The product cases must be washed and sanitized regularly.
- Do not use any abrasive material or cleaners on the dispenser.
- Do not clean the dispenser in the vicinity of a water jet.
- Do not spray any liquid or cleaners in or around the dispense point or inside the dispenser. Liquid could damage electrical components of the dispenser.

RECOMMENDED CLEANING SCHEDULE

Descriptions of the cleaning procedures follow the table.

Part or area	Frequency
<ul style="list-style-type: none">• Exterior and button panel• Cup guide• Catch tray	Daily
<ul style="list-style-type: none">• Product case, product case insert• Product compartment	Inspect and clean, as required, every time a new product bag is loaded
<ul style="list-style-type: none">• Door gasket• Valve assembly	Monthly or more frequently, as required
<ul style="list-style-type: none">• Condenser	Every six months

Table 1: Recommended cleaning schedule

CLEANING INSTRUCTIONS

Exterior and Button Panel

1. Press and hold the **lock button** on the button panel until the display shows **LOCKED** and the SureShot symbol is solid yellow. This will prevent accidentally dispensing product while cleaning the exterior.
2. Wipe plastic exterior surfaces using a soft cloth dampened with warm, clean, and soapy water.
3. Wipe using a soft cloth dampened with warm, clean water.
4. Dry with a soft cloth to prevent water spotting.
5. A stainless-steel cleaner is recommended for the metal surfaces. Spray cleaner on a cloth and then use cloth to wipe the exterior. Use on stainless steel surfaces only.
6. Press and hold the **lock button** to resume dispensing.



Do not allow stainless-steel cleaner to come into contact with the button panel or any plastic parts. Do not use any ammonia-based cleaners such as a window cleaner.

Cup Guide

For models with a cup guide, follow these instructions:

1. Lift the two ends of the cup guide up to the top of the keyholes.
2. Pull the two ends of the guide out of the keyholes.
3. If a dishwasher is available, the cup guide can be cleaned on the full wash cycle. If a dishwasher is not available:
 - a. Rinse thoroughly with warm, clean water.
 - b. Wash in hot water (minimum 140°F/60°C) with a good quality cleaner. Wash thoroughly to reach all corners and crevices.
 - c. Rinse well with warm, clean water.
4. Air-dry thoroughly.
5. Replace the cup guide by pushing the two ends of the cup guide into the keyholes on the front of the dispenser and pushing down to secure it.

Catch Tray

For models with a catch tray:

1. Pull the catch tray away from the dispenser so that the grooves unhook from the front legs.
2. Separate the two parts (screen and tray).
3. If a dishwasher is available, the two parts of the catch tray can be cleaned on the full wash cycle. If a dishwasher is not available:
 - a. Rinse thoroughly with warm, clean water.
 - b. Wash in hot water (minimum 140°F/60°C) with a good quality cleaner. Wash thoroughly to reach all corners and crevices.
 - c. Rinse well with warm, clean water.
4. Air-dry thoroughly.
5. Put the two parts (screen and tray) back together.
6. Replace the catch tray.
 - a. Set the catch tray on the counter and line up the two grooves with the front legs.
 - b. Push the catch tray so the grooves hook in place around the legs.

Dairy Bag Stopper

For models with a dairy bag stopper, wash, rinse, and sanitize in a 3-compartment sink and then air dry (do not clean the stopper in a dishwasher). If a more thorough cleaning is required, separate the stopper into three parts (top, bottom and spring). Push the top of the stopper down into the bottom as far as it will go and then twist the top to unlock and separate.

Product Case, Product Case Insert, and Product Compartment

1. Open dispenser door.
2. Remove the product case from the product compartment.
3. Remove the bag and insert (if applicable) from the product case.
4. If a dishwasher is available, the product case and insert (if applicable) can be cleaned on the full wash cycle. If a dishwasher is not available:
 - a. Rinse thoroughly with warm, clean water.
 - b. Wash in hot water (minimum 140°F/60°C) with a good quality cleaner. Wash thoroughly to reach all corners and crevices.
 - c. Rinse well with warm, clean water.
5. Dry thoroughly with a soft cloth or air-dry.
6. With the product case already removed, wipe inside the product compartment using a soft cloth dampened with warm, clean, and soapy water.
7. Wipe using a soft cloth dampened with warm, clean water.
8. Dry thoroughly with a soft cloth.
9. Load the product case with either a full bag or the previous bag into the product compartment.
10. Close dispenser door.

Door Gasket

1. Open dispenser door.
2. Inspect the door gasket to make sure that there are no cuts or gaps.
3. Wipe the gasket using a soft cloth dampened with warm, clean, and soapy water. Use a small brush to reach all the corners and crevices.
4. Wipe using a soft cloth dampened with warm, clean water.
5. Dry thoroughly with a soft cloth.
6. Close dispenser door.

Valve Assembly

The valve assembly must be kept clean for proper sanitation and to maintain accurate dispense amounts. The dispense tube goes through the valve block, and it is held in place by the valve insert and plunger.

Prior to taking the valve assembly apart, prepare containers of

- warm, clean, and soapy wash water
- warm, clean rinse water
- sanitizing agent approved by your organization

1. Turn off the dispenser.
2. Open dispenser door.
3. Push in the plunger with one hand and pull the valve insert down and out with the other hand.



The valve insert is magnetic and can be attached to the front panel for safekeeping.

4. Remove the plunger by pulling it straight out.

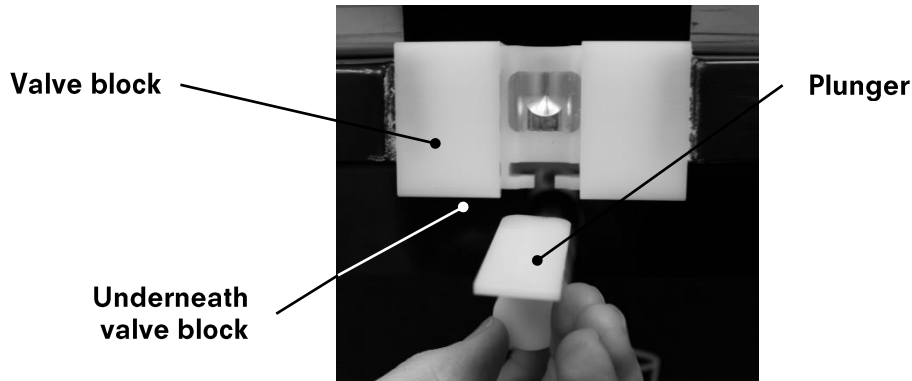

Figure 62: Remove the plunger

5. Using the containers listed above, clean, rinse, and sanitize the valve insert and plunger.
6. Dry thoroughly with a soft cloth.
7. Wipe the inside and the outside of the valve block using a soft cloth dampened with warm, clean, and soapy water. If required, use a small brush to reach all the corners and crevices that are inside and underneath the valve block.
8. Wipe using a soft cloth dampened with warm, clean water.
9. Dry thoroughly with a soft cloth.
10. Insert the plunger. If you are reloading the product cases, do so now.
11. Reinstall the valve insert.
12. Close the door of the dispenser.
13. Turn on the dispenser.

Condenser

1. Turn off the dispenser.
2. Unplug the dispenser.
3. Remove the lower back panel by removing the screws that secure it in place. Carefully pull the back panel off of the dispenser.
4. Gently clean the condenser using a vacuum with a soft brush attachment. Using a vacuum prevents damage to the condenser coil.



The condenser fins are very sharp and can cause cuts, even if touched gently. Do not touch the condenser fins.

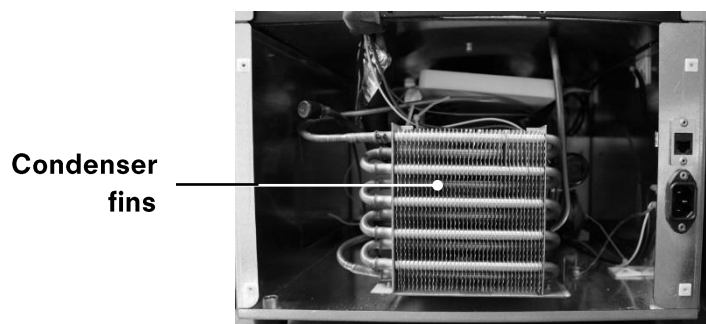

Figure 63: Condenser

5. Reinstall the back panel using the screws removed in step 3 to secure the panel in place.
6. Plug in the dispenser.
7. Turn on the dispenser.

TROUBLESHOOTING

If the troubleshooting instructions do not correct the problem, contact the SureShot Solutions Technical Assistance Center at 888 777-9990 (USA & Canada) or +1 902 865 9602.

Problem	Action
Dispenser does not turn on	<ol style="list-style-type: none"> 1. Make sure the dispenser is plugged into an active power source. If power source does not have power, have a qualified person check your facility's fuse box or circuit breaker to restore power. 2. Make sure the power switch is in the on position. 3. Make sure the dispenser's circuit breaker has not tripped. <ol style="list-style-type: none"> a. Turn the power off. b. Locate and depress the circuit breaker below the power switch to make sure it has not tripped. <ul style="list-style-type: none"> • No white should be showing. If white is showing on the top of the breaker, it has tripped. • The switch will make a clicking noise when depressed. c. Turn the power on.
Display on the front door is blank	<ol style="list-style-type: none"> 1. Press a beverage type button, shot quantity button, and product/cup size button. <ol style="list-style-type: none"> a. If you do not hear the valve snap open, try the actions in the <i>dispenser does not turn on</i> troubleshooting problem. b. If you do hear it snap open, the display may be faulty.
Dispenser does not dispense product	<ol style="list-style-type: none"> 1. Make sure the main door is closed. 2. Make sure all required selections have been made. 3. Make sure the product loading procedures have been completed. 4. Make sure the product tube is not twisted, kinked, pinched, or blocked. 5. Make sure the product is not frozen in the tube. 6. Make sure the recipe amounts are configured correctly and are not set to zero. 7. Make sure the valve assembly is clean. 8. Remove the valve assembly and make sure the plunger is not broken. 9. Turn the dispenser off, wait 10 seconds, and then turn the dispenser back on. This resets the program. 10. Make sure all actions are followed for the <i>dispenser does not turn on</i> troubleshooting problem.
Dispense amounts are incorrect	<ol style="list-style-type: none"> 1. Make sure the plunger and valve insert are installed correctly. 2. Make sure the product tube is properly aligned in the center of the valve and is not twisted, kinked, pinched, or blocked. 3. Make sure the dairy bag, as it sits inside the product case, does not have a fold that obstructs product flow to the tube. 4. Make sure the product is not frozen in the tube. 5. Make sure the product temperature is between 34°F and 40°F (1.1°C and 4.4°C). Temperature affects the flow of dairy. 6. Make sure the valve assembly is clean. 7. Make sure the recipe amounts are configured correctly and are not set to zero. 8. Make sure the correct product and bag type is selected.

Problem	Action
	<ol style="list-style-type: none"> 9. Make sure the product level indicator on the display matches the amount that is in the bag. 10. Make sure a proper calibration has been performed.
<p>Dispenser is leaking product or water</p>	<p>Leaking product:</p> <ol style="list-style-type: none"> 1. Make sure the valve insert is installed. 2. Make sure the product tube is properly aligned in the center of the valve. 3. Make sure the product tube does not have any holes or cracks. 4. Make sure the dairy bag does not have any holes. 5. Make sure the fitment on the dairy bag is securely attached to the bag. 6. Make sure the valve assembly is clean. 7. Remove the valve assembly to make sure that the plunger is not broken. 8. Make sure the valve assembly is assembled and installed correctly. <p>Leaking water from underneath the dispenser:</p> <ol style="list-style-type: none"> 1. There should be no ice buildup inside the product compartment. However, there could be condensation that builds up inside the bottom half of the dispenser that collects in a condensate tray. Condensation could be caused by reasons such as a high humidity environment and frequent or prolonged door opening. In these cases, the condensation may not evaporate quickly enough from the condensate tray causing some water to leak from the dispenser. 2. The condensation overflow drain hose is located just behind the front right leg. Wipe up any water that may have come from this area.
<p>Product temperature is too warm or too cold</p>	<ol style="list-style-type: none"> 1. Make sure the dispenser is not too close to a heat-generating source, such as a coffee maker, heat lamp, or direct sunlight. 2. Make sure there is a minimum 1 in. (2.5 cm) air space on all sides of the dispenser. 3. Make sure the condenser fan at the back of the dispenser (located behind the condenser) is not blocked. 4. Make sure the condenser is not dirty. 5. Make sure the dispenser is level. The dispenser must be level for the refrigeration system to operate properly. 6. Make sure the fan is operating. The fan turns on when the compressor is on and turns off when compressor is off. If the little snowflake icon is visible near the temperature reading on the display, the compressor is on. 7. Make sure nothing is obstructing the intake holes on the underside of dispenser. 8. Adjust the refrigeration setting. A refrigeration setting of '0' means the dispenser's refrigeration system is turned off.

SERVICE AND WARRANTY

The warranty on this product is for one year for on-site parts and labor, and it includes access to the USA- and Canada-wide Technical Service Network.

The warranty will be null and void if the dispenser is serviced by unqualified personnel. Under warranty, service technicians must be approved and dispatched by the SureShot Solutions Technical Assistance Center. The customer is responsible for all costs not approved by SureShot Solutions.

Contact the SureShot Solutions Technical Assistance Center at 888 777-9990 (USA & Canada) or +1 902 865 9602 for approval.

If you are within the warranty period for your dispenser, please contact:

SureShot Solutions Technical Assistance Center
A.C. Dispensing Equipment Inc.
888 777-9990 (USA & Canada) or +1 902 865 9602
www.sureshotsolutions.com
service@sureshotsolutions.com

If your warranty has expired, feel free to contact the SureShot Solutions Technical Assistance Center for telephone support. If you require on-site repairs, please contact your local Service Technician.

Parts can be ordered through the SureShot Solutions website:
www.sureshotsolutions.com.



The serial number and model number of your dispenser are located on the product identification label on the inside of the dispenser. Please refer to these numbers when contacting the SureShot Solutions Technical Assistance Center. These numbers are crucial in helping us provide prompt and effective service. This will save you time.

**Product identification
label**

Service label



Figure 64: Product identification label

USA AND CANADA WARRANTY

This dispenser is covered by a one (1) year on-site warranty, unless otherwise specified.

All dispensing equipment manufactured by A.C. Dispensing Equipment Inc. is warranted against defects in materials and workmanship for a period of one (1) year from the date of purchase.

A.C. Dispensing Equipment Inc.'s obligation under this warranty is limited to the repair of defects as outlined by an A.C. Dispensing Equipment Inc. factory-authorized service agency or one of its sub-service agencies.

This warranty does not apply to installation or problems caused by installation. This warranty does not apply to normal preventative maintenance, maintenance, or adjustments deemed appropriate by A.C. Dispensing Equipment Inc.

THIS WARRANTY WILL BE NULL AND VOID IF THE DISPENSER'S WARRANTY HAS NOT BEEN REGISTERED WITH A.C. DISPENSING EQUIPMENT INC. WITHIN 60 DAYS OF PURCHASE.

This warranty is subject to the following conditions:

- This warranty applies to the original owner only and is not assignable.
- Only pre-authorized service agencies directed by A.C. Dispensing Equipment Inc. are to be utilized.
- Should any product fail to function in its intended manner under normal use within the limits defined in this warranty, at the option of A.C. Dispensing Equipment Inc., such product will be repaired or replaced by A.C. Dispensing Equipment Inc. or its authorized service agency. A.C. Dispensing Equipment Inc. will be responsible only for charges incurred or service performed by its authorized service agencies. The use of other than A.C. Dispensing Equipment Inc. authorized service agencies will void this warranty and A.C. Dispensing Equipment Inc. will not be responsible for such work or any charges associated with such work. The closest A.C. Dispensing Equipment Inc. authorized service agency must be used and must be dispatched by A.C. Dispensing Equipment Inc.

TIME PERIOD

One year on parts and labor, effective from the date of purchase. The authorized service agency may, at its option, require proof of purchase. Parts replaced under this warranty are warranted for the unexpired portion of the original product warranty only.

A service consultant is available to assist you during our normal business hours. All service-related issues will be addressed with a return telephone call by the next business day.

WARRANTY PROCEDURE

1. Find and write down the serial number and model number from the product identification label. If a part or option code number is also listed, write down this number too.
2. Call the number provided on the service label on the dispenser.
3. Our Technical Assistance Center staff will discuss the issue with you and, if necessary, dispatch a technician to your location for repairs. If after-hours or emergency assistance is required, A.C. Dispensing Equipment Inc. will not be responsible for any additional charges.

4. To order parts, call the service center and the appropriate parts will be sent to your location or that of the servicing agency.

The following procedures and conditions are not covered by this warranty:

- Equipment failure related to improper installation, improper utility connection or supply, or problems due to ventilation.
- Equipment that has not been properly maintained, calibration controls, adjustments, damage from improper cleaning, and water damage to controls.
- Equipment that has not been used in an appropriate manner or has been subject to misuse or misapplication, neglect, abuse, accident, alteration, negligence, damage during transit, delivery or installation, fire, flood, riot, or act of God.
- Equipment on which the model number or serial number has been removed or altered.
- If the equipment has been changed, altered, modified, or repaired by other than a qualified service technician during or after the warranty period, then the manufacturer shall not be liable for any damages to any person or property which may result from the use of the equipment thereafter.
- Any and all adjustments deemed appropriate for the customer to perform will not be covered under warranty (i.e., temperature adjustment, leveling of the unit by its leg extensors, adjustments to portion control, resetting of the circuit breaker found on the unit, tube positioning, temperature offset adjustment, or any other adjustment that can be performed by the operator of the unit deemed necessary by A.C. Dispensing Equipment Inc.).
- All warranty calls will be strictly monitored. Any parts that are used may be required to be returned to the manufacturer for examination with the signed field report outlining all work performed on the unit. For any part replaced that is found not to be defective, A.C. Dispensing Equipment Inc. reserves the right to refuse payment for the associated replacement part(s).
- All preventative maintenance and cleaning requirements will not be covered under warranty.

This warranty does not cover services performed at overtime or premium labor rates. Should service be required at times which normally involve overtime or premium labor rates, the owner shall be charged for the difference between normal service rates and such premium rates. A.C. Dispensing Equipment Inc. does not assume any liability for extended delays in replacing or repairing any items beyond its control.

In all cases, the use of other than A.C. Dispensing Equipment Inc. authorized OEM replacement parts will void this warranty.

This equipment is intended for commercial use only. Warranty is void if equipment is installed in other than commercial applications.

THE FOREGOING WARRANTY IS IN LIEU OF ANY AND ALL OTHER WARRANTIES EXPRESSED OR IMPLIED, INCLUDING ANY IMPLIED WARRANTY OF MERCHANTABILITY OR FITNESS AND CONSTITUTES THE ENTIRE LIABILITY OF A.C. DISPENSING EQUIPMENT INC. IN NO EVENT DOES THE LIMITED WARRANTY EXTEND BEYOND THE TERMS STATED HEREIN.

SURESHOT
SOLUTIONS

A.C. Dispensing Equipment Inc.
100 Dispensing Way
Lower Sackville, Nova Scotia
B4C 4H2 CANADA
888 777-9990 (USA & Canada) or +1 902 865 9602
www.sureshotsolutions.com