

AC-LC1

Liquid Cooler Dispenser

SureShot
liquid cooler

Operations Manual



AC-LC1
Liquid Cooler Dispenser

SureShot liquid cooler

FEATURES

- Quick cool – 2 pots in less than 3 minutes
- Easy to fill input tank will hold up to 2 pots of liquid
- Holding tank for cooled liquid holds up to 5 pots of liquid
- Accommodates a variety of cup sizes with a maximum cup height of 8" (20cm)
- Quick dispense
- Clean, non-drip dispense faucet
- Compact countertop design
- Satin coated stainless steel casing
- Stainless steel nickel brazed heat exchanger
- One year on-site warranty

TABLE OF CONTENTS

Introduction	1
Components	1
Specifications	1
Servicing and Warranty	2
Inspect for Damage	2
Reshipment	2
Unpacking the Dispenser	2
Attach Dispense Faucet	3
Dispenser Requirements	3
Safety Precautions	3
Electrical and Water	3
Locating the Dispenser in your Facility	3
Cleaning	4
Exterior	4
Tanks, Heat Exchanger, Dispense Faucet and Lines	4
Sanitizing and Destaining	5
Drainage Panel	6
Installation	6
Plumbing	6
Operating The Dispenser	7
Turning on the Dispenser	7
Loading Product	7
Dispensing Product	7
Timing Plate	7
Troubleshooting	8
Wiring Diagram	9
Warranty	11



SureShot Technical Assistance Center
1-888-777-9990 or 902-865-9602

service@sureshotdispensing.com
parts@sureshotdispensing.com
www.sureshotdispensing.com

A.C. Dispensing Equipment Inc.
100 Dispensing Way
Lower Sackville, Nova Scotia
Canada B4C 4H2



LIQUID COOLER DISPENSER OPERATIONS MANUAL

Important: Read this Manual now and retain it for future reference

THE DISPENSER

The SureShot Dispensing Systems® AC-LC1 Liquid Cooler Dispenser is a simple, effective and efficient tool for making hot liquids cold. In less than three minutes two pots of hot liquid, including coffee, hot chocolate or tea, will be cooled by simply pouring the hot liquid in the top of the dispenser. It is then ready for a quick, clean dispense. Up to five pots can be held and available for use.

MAIN COMPONENTS

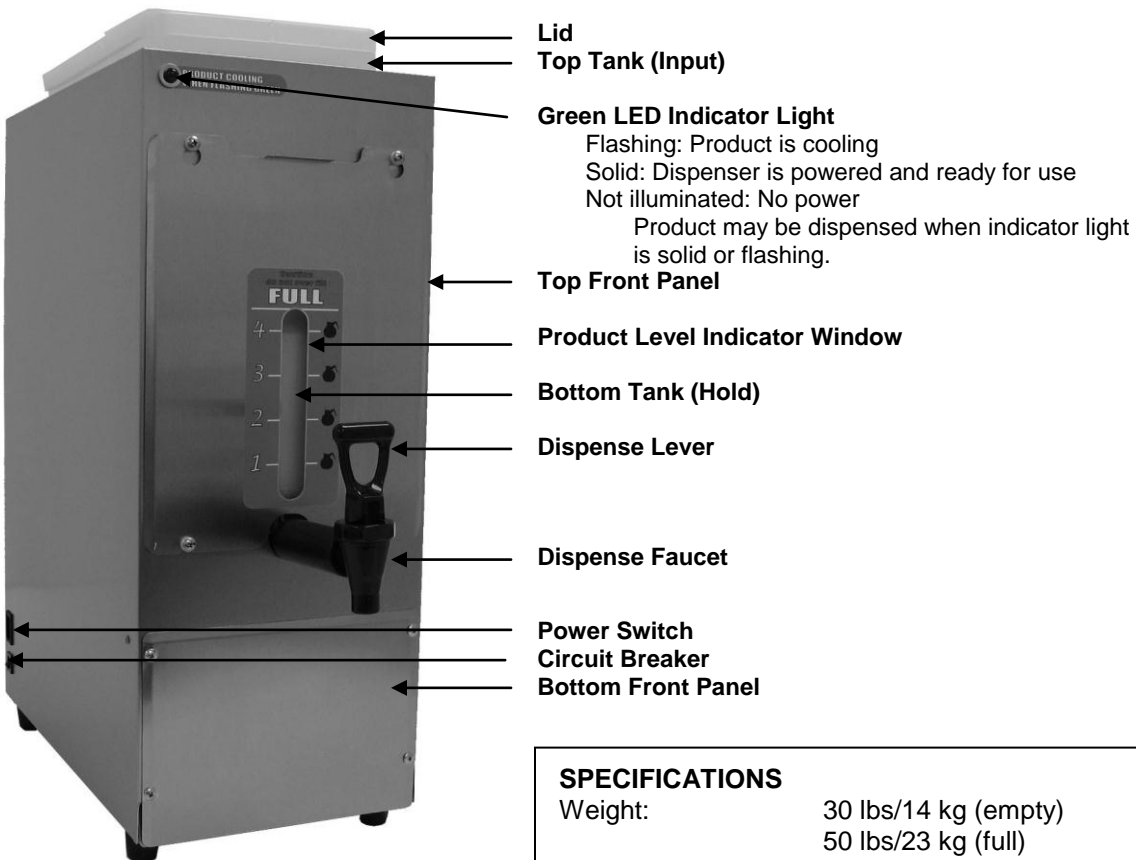

AC-LC1

SPECIFICATIONS	
Weight:	30 lbs/14 kg (empty) 50 lbs/23 kg (full)
Dimensions (LxWxH):	20" x 9" x 24"
Capacity:	Top Tank: 3.6 Liters/ 1 Gallon Bottom Tank: 9.0 Liters/ 2.5 Gallons
Tanks are made of food-grade plastic.	

Servicing and Warranty

Standard warranty is one year, on-site parts and labour.
Access to USA and Canada-wide Technical Service Network.

The Warranty (page 11) will be null and void if the dispenser is serviced by unqualified personnel. Under warranty, service technicians must be approved and dispatched by the SureShot Technical Assistance Center.

Contact the SureShot Technical Assistance Center at 1-888-777-9990 or 902-865-9602 for approval.

The customer is responsible for all costs not approved by SureShot Dispensing Systems®.

Inspect for Damage

***Note:** Damages incurred during shipment are not the responsibility of SureShot Dispensing Systems® and are not covered by Warranty.*

If you haven't already done so, inspect packaging material for damage. Note any damage in detail.

Unpack the dispenser immediately following the directions below. Examine the dispenser for damage. Report any damage to the transportation company and file a claim for damages within 24 hours. Your immediate inspection and reporting protects you against loss.

Notify SureShot Dispensing Systems® within 24 hours of any damage claims. No returns will be accepted without prior approval. Obtain an authorized return number by contacting the SureShot Technical Assistance Center at 1-888-777-9990 or 902-865-9602.

Reshipment

If packaging is not available, it may be purchased from the SureShot Parts Department by calling 1-888-777-9990 or 902-865-9602.

Ensure pieces which may shift in transit are secured using masking tape.

No returns will be accepted without prior approval. Obtain an authorized return number by contacting the SureShot Technical Assistance Center at 1-888-777-9990 or 902-865-9602.

Unpacking the Dispenser

1. Position the box with the "This Side Up" arrow pointing upward.
2. Cut the packing straps from the box.
3. Lift the top from the box.
4. Remove the box sleeve by lifting it up and off the dispenser.
5. Lift the dispenser off the bottom of the box and place it on the counter.
6. Caution: Always lift the dispenser from the bottom.
7. Remove the plastic protective covering from the stainless steel exterior. Hold the dispenser firmly at the top and peel in sections from top to bottom.
8. Prior to use, read the Operations Manual and store it for future reference.

Attach Dispense Faucet

The dispense faucet is shipped inside bottom tank and must be installed.

1. Locate dispense faucet.
2. Ensure faucet is aligned with valve spout to avoid cross-threading.
3. Turn clockwise until tight to avoid leakage.
The valve spout is located on the bottom tank at the front of the dispenser.

DISPENSER REQUIREMENTS

Safety Precautions

- Always plug the dispenser into an approved electrical outlet.
- The dispenser includes a microcontroller and must be operated on grounded electrical wiring at all times.
- Unplug the dispenser from its electrical source before servicing.
- Do not immerse the dispenser in water.
- Observe all safety precautions with this dispenser that you would with any electrical appliance.
- Always use caution when working with hot liquids.

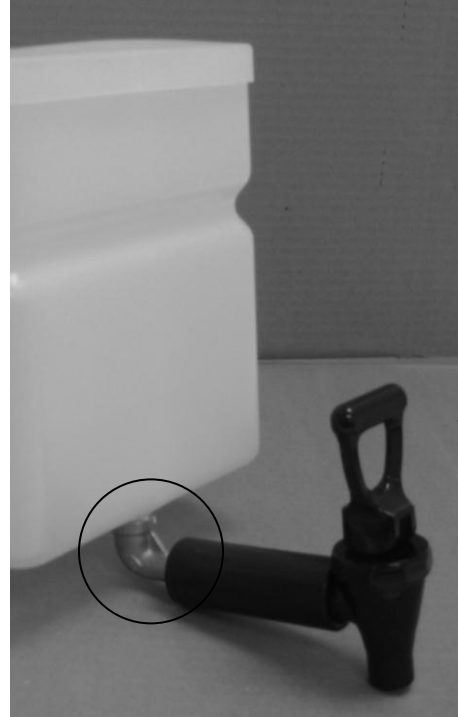

Dispense faucet shown installed onto valve spout of bottom tank.

Electrical and Water

Power: 120 VAC, 60 Hz, .15 amp, 1 ph

Water: Cold water supply line with a minimum of 6 liters (1.5 gallons) per minute

Water pressure should be between 25–75 psi

Inlet: 0.25" Male S.A.E. 45° Flare Fitting

Outlet: 3/8" OD / 1/4" ID

Access to free drain

Note: A certified plumber is required for installation. See page 6.

Locating the Dispenser in your Facility

- This dispenser is not suitable for outdoor use.
- Place the dispenser where it will best serve your operation.
- Place the dispenser at the appropriate serving height so that users of the dispenser can operate the dispense faucet and easily place and remove cups.
- Do not place the dispenser too close to a source of heat or moisture.
- The dispenser should be placed on a level surface. The dispenser does not require levelling for normal operation.
- Counters, platforms, or shelves should be strong enough to support the dispenser and a full product load. The empty dispenser weighs 30 lbs/14 kg. The full dispenser weighs 50 lbs/23 kg.

CLEANING

- Do not use any abrasive material or cleaners on the dispenser.
- Dispenser must not be cleaned by water jet.
- Do not spray any liquid or cleaners in or around the inside of the dispenser. Liquid could damage electrical components of the dispenser.
- Dispose of liquids flushed through dispenser during cleaning procedure.
- When flushing dispenser during cleaning procedure, use an appropriately sized container that can easily be handled as it will contain hot liquid. It may be necessary to stop flow after partial drainage. Empty the container each time it is filled and continue draining as required.

Exterior

1. Wipe exterior surfaces using a soft cloth dampened with warm, clean, soapy water. A stainless steel cleaner is recommended. Use on stainless steel surfaces only.
Note: Do not allow stainless steel cleaner to come in contact with the plastic faucet.

Tanks, Heat Exchanger, Dispense Faucet and Lines

Daily Cleaning

Note: Top Tank should not be removed.

1. Ensure green LED indicator light is solid and not flashing.
2. Turn **off** power switch.
3. Open dispense faucet and drain any remaining product into an appropriately sized container.
 - a. Open dispense faucet by tilting lever into the lock position.
Lever can be tilted both directions.
 - Tilting lever fully in one direction, to a horizontal position, locks the faucet open.
 - Tilting lever in the opposite direction allows it to close automatically when released.
4. Flush with water.
 - a. With dispense faucet open, pour 2 pots of hot water (160°F/70°C) into top tank and allow to flush through and into an appropriately sized container.
Caution: Liquid will be very hot!
5. Remove top front panel located above dispense faucet by sliding up until screw heads align with larger parts of keyhole openings. Lift off.
6. Grasp dispense faucet of bottom tank and slide straight out just far enough to then grasp sides of tank for complete removal. **Do not use dispense faucet to carry tank.**
7. Remove lid from top tank by lifting it up and off dispenser. Set aside.
8. Wash bottom tank, both lids and dispense faucet in hot water with a good quality cleaner at a minimum water temperature of 140°F/60°C. Wash thoroughly to reach all corners and crevices.
If a dishwasher is available the items may be cleaned on the full wash cycle.
9. Rinse well with warm, clean water ensuring water is also flushed through dispense faucet.
10. Air dry thoroughly.

11. Replace lids on both tanks.
12. Slide bottom tank completely back into dispenser.
13. Ensure hole in the back of the bottom tank aligns with the hose inside the back of the dispenser. See photo on right.
14. Replace front panel by aligning screw heads on the dispenser with large parts of keyhole openings on the panel. Slide down into place.
15. Flush with product.

The heat exchanger and lines contain water after cleaning. This needs to be flushed out with product prior to regular use.

 - a. With dispense faucet open, pour a half pot of product into top tank and allow to flush through into an appropriately sized container.
16. Close dispense faucet.
17. Turn on power switch.
18. Load product. See page 7.

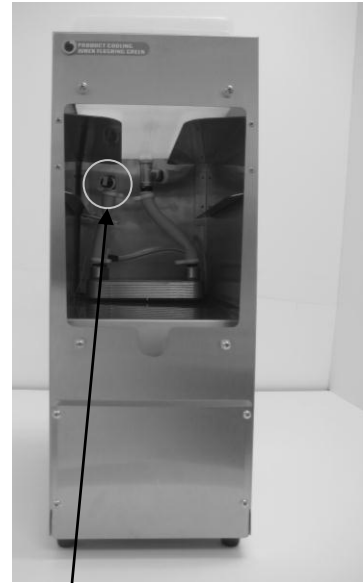

Step 13. Dispenser with top front panel and top tank removed shows hose inside the back of the dispenser

Sanitizing and Destaining

- Sanitizing is required prior to first use and recommended each month and after the destaining procedure.
- Destaining is recommended using existing guidelines, including destaining cleaner and schedule, as with other equipment in your facility and recommended by your organization.

Use appropriate Sanitizing solution or Destaining solution approved by your organization in the following steps.

1. Ensure green LED indicator light is solid and not flashing.
2. Turn **off** power switch.
3. Open dispense faucet and drain any remaining liquid into an appropriately sized container.
 - a. Open dispense faucet by tilting lever into the lock position.

Lever can be tilted both directions.

 - Tilting lever fully in one direction, to a horizontal position, locks the faucet open.
 - Tilting lever in the opposite direction allows it to close automatically when released.
4. Flush with water.
 - a. Pour 2 pots of hot water (160°F/70°C) into top tank and allow to flush through and into an appropriately sized container.

Caution: Liquid will be very hot!

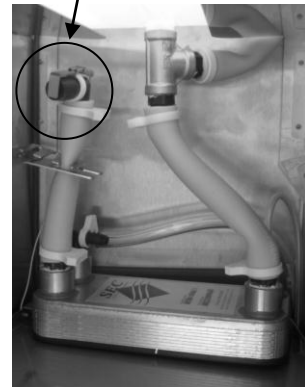

Heat exchanger

5. Sanitize or Destain.
 - a. Close dispense faucet.
 - b. Pour 2 pots of solution into top tank. Wait for top tank to empty. Repeat for a total of 5 pots to fill bottom tank, heat exchanger and lines.
 - c. Plug top tank. Plug is stored on the top of the dispenser at the back. Insert plug into hole located in the bottom of the top tank towards the back.
 - d. Pour 1 pot of solution into top tank.
 - e. Let stand 5 minutes.
 - f. Open dispense faucet and drain solution from bottom tank into an appropriately sized container.
 - g. Remove plug and allow solution to drain from top tank to bottom tank and into an appropriately sized container.
 - h. Rinse plug and return to storage hole.
6. Flush with water.
 - a. With dispense faucet open, pour 2 pots of hot water (160°F/70°C) into top tank and allow to flush through into an appropriately sized container.
Caution: Liquid will be very hot!
7. Flush with product.

The heat exchanger and lines will have water in them after cleaning. This needs to be flushed out with product prior to regular use.

 - a. With dispense faucet open, pour a half pot of product into top tank and allow to flush through into an appropriately sized container.
8. Close dispense faucet.
9. Turn on power switch.
10. Load product. See page 7.



Step 5c. Plug

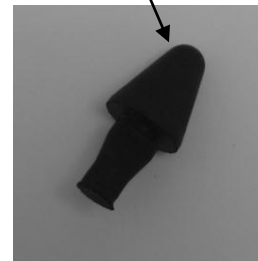

Drainage Panel

- In the event of overfilling, liquid will flow down and through the front of the dispenser.
1. Remove bottom front panel by removing the four (4) screws below and to each side of the dispense faucet.
 2. Wipe the drainage area and the removed front panel using a clean, soft cloth dampened with warm, clean, soapy water.
 3. Dry thoroughly.
 4. Replace bottom front panel with screws removed in step 1.

INSTALLATION

Plumbing

Note: A certified plumber is required for installation which is your responsibility.

Water: Cold water supply line with a minimum of 6 liters (1.5 gallons) per minute

Water pressure should be between 25–75 psi.

Inlet: 0.25" Male S.A.E. 45° Flare Fitting.

Outlet: 3/8" OD / 1/4" ID.

Access to free drain.

The length of the outlet/drain line is not critical.

Outlet/drain line diameter must not be smaller than specifications above by changing line, adding fittings or couplers, kinking, crimping or pinching. Increasing outlet/drain line diameter is acceptable.

The orientation of the outlet/drain line must always be a negative/downward slope.

Plumbing must meet local codes and requirements.

OPERATING THE DISPENSER

Turning on the Dispenser

1. Plug the power cord from the dispenser into an AC electrical wall outlet.
2. Turn power switch to ON. Power switch is located on the left side of dispenser toward the back, near the bottom. A green LED light on the front, top left corner of the dispenser illuminates to indicate the power is ON.

Loading Product

1. Ensure green LED indicator light on front, top left corner of dispenser is solid and not flashing.
 - Flashing: Product is cooling
 - Solid: Product is cooled and ready for use
 - Not illuminated: No power
2. Open the front portion of the lid on the top of the dispenser by tipping it up and over towards the back.
3. Pour up to 2 pots of hot liquid into top tank of dispenser.
Note: Do not pour more than 2 pots of liquid into the dispenser at a time as it may overflow.
4. Liquid will flow out of the top tank, through the heat exchanger located inside the dispenser and then into the bottom tank. Two pots will take approximately 3 minutes.
Caution: Always check fill indicator window on front of dispenser prior to pouring additional hot liquid into top tank. Ensure bottom tank will accommodate additional amounts of hot liquid being poured into dispenser to avoid overflow.

Dispensing Product

1. Hold or place cup under dispense faucet.
2. Pull or push dispense lever to dispense cooled liquid.
3. Return lever to upright position when desired quantity has been dispensed.

TIMING PLATE

The amount of time that the cooling process takes can be adjusted. Adjustment may be required for additional cooling time of hot liquid due to variances in temperature of cold tap water.

1. Remove six (6) screws from the back of the dispenser.
2. Remove panel. Set aside.
3. Locate timing plate. It is slid onto a hose inside the back of dispenser on the right.
4. Grasp timing plate and slide it off of the hose.
5. Replace timing plate by sliding it back onto the hose with desired slot aligned to hose.

Note: Ensure notch is on the left and prongs are pointing away from you for correct timing plate position.

See photo on right for description of timing plate.

Slot 1 – 1 minute, 40 second cooling time per pot (default)

Slot 2 – 1 minute, 50 second cooling time per pot

Slot 3 – 2 minute cooling time per pot

Note: Changing hose location in timing plate to increase cooling time will increase cold water consumption.



Timing Plate

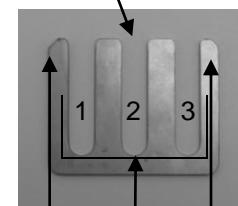

Notch Slot Prong

TROUBLESHOOTING

Problem	Action
Dispenser does not turn on	<ol style="list-style-type: none"> 1. Ensure dispenser is plugged into an active power source. If power source does not have power, have a qualified person check your facility's fuse box or circuit breaker to restore power. 2. Ensure power switch is in the ON position. 3. Ensure dispenser's circuit breaker has not popped. <ol style="list-style-type: none"> a. Turn the power switch to the OFF position. b. Locate and depress the 1 amp circuit breaker below the power switch to make sure it has not popped. <ul style="list-style-type: none"> • No white should be showing. If white is showing on the top of the breaker, it is tripped. • It will make a clicking noise when depressed. c. Turn the power switch to the ON position. <p>If dispenser still does not turn on, contact the SureShot Technical Assistance Center at 1-888-777-9990 or 902-865-9602.</p>
Green LED light does not stop flashing	<ol style="list-style-type: none"> 1. Turn dispenser power off and then back on. <p>If green LED light continues to flash, contact the SureShot Technical Assistance Center at 1-888-777-9990 or 902-865-9602.</p>
Dispenser will not dispense liquid	<ol style="list-style-type: none"> 1. Ensure dispenser is plugged into an active power source. If power source does not have power, have a qualified person check your facility's fuse box or circuit breaker to restore power. 2. Ensure power switch is in the On position. 3. Ensure there is liquid in the bottom tank. 4. Ensure the top tank's drain is not blocked. 5. Ensure dispense faucet is not blocked. 6. Ensure non-clear hoses are not twisted, kinked, pinched off or blocked. Check for blockage by pinching along the length of the hose with fingers, feeling for solid debris. <p>If dispenser still does not dispense liquid, contact the SureShot Technical Assistance Center at 1-888-777-9990 or 902-865-9602.</p>
Hot or warm liquid is being dispensed	<ol style="list-style-type: none"> 1. Ensure the water supply line is attached to a cold water supply. 2. Adjust timing plate for increased cooling time. See page 7. <p>If this does not correct the problem, contact the SureShot Technical Assistance Center at 1-888-777-9990 or 902-865-9602.</p>
Dispenser is leaking	<p>Leaking Product:</p> <ol style="list-style-type: none"> 1. Ensure dispense faucet is tightly connected by turning clockwise. 2. Ensure dispense lever is tightly connected 3. Ensure tank has not been overfilled. 4. Check for holes, cuts or cracks in non-clear hoses and tanks. 5. Check for leaks at fittings of non-clear hoses. <p>Leaking Water:</p> <ol style="list-style-type: none"> 1. Check for holes, cuts or cracks in clear hoses. 2. Check for leaks at fittings of clear hoses. <p>To access hoses</p> <ol style="list-style-type: none"> 1. Remove bottom tank. Access through opening. 2. Remove back panel by removing the six (6) screws. <p>If dispenser continues to leak, contact the SureShot Technical Assistance Center at 1-888-777-9990 or 902-865-9602.</p>

WIRING DIAGRAM

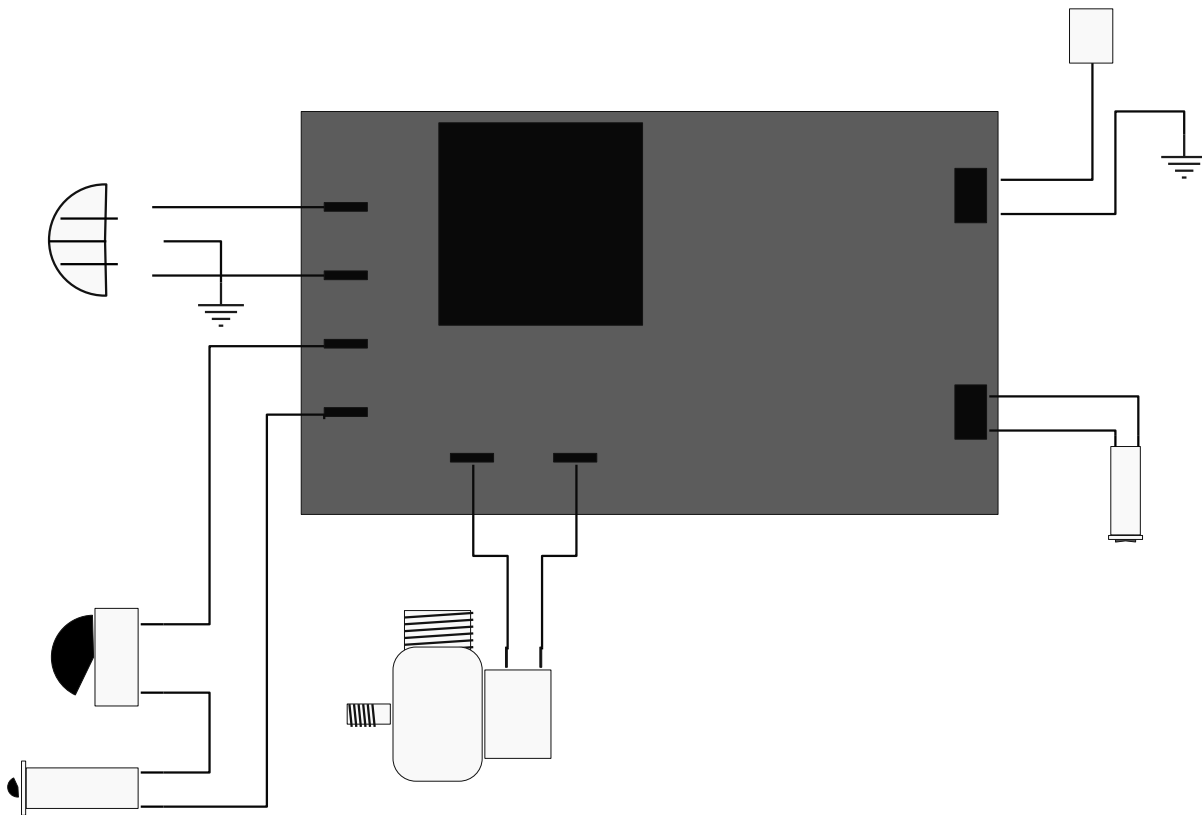

For service, if you are within the Warranty Period for your dispenser, please contact:
SureShot Technical Assistance Center
A.C. Dispensing Equipment, Inc.
1-888-777-9990 or 902-865-9602
www.sureshotdispensing.com
service@sureshotdispensing.com

If your Warranty has expired, contact your local Service Technician.

Note: The Serial Number, Model Number and Option Code of your dispenser are located on the Product Identification Label on the outside of the dispenser. Please refer to these numbers when contacting the SureShot Technical Assistance Center. These numbers are crucial in helping us provide prompt and effective service. This will save you time.

NORTH AMERICAN WARRANTY

This dispenser is covered by a one (1) year on-site warranty, unless otherwise specified.

All dispensing equipment manufactured by A.C. Dispensing Equipment Inc. is warranted against defects in materials and workmanship for a period of one (1) year from the date of purchase.

A.C. Dispensing Equipment Inc.'s obligation under this warranty is limited to the repair of defects as outlined by an A.C. Dispensing Equipment Inc. factory-authorized service agency or one of its sub-service agencies.

This Warranty does not apply to installation or problems caused by installation. This Warranty does not apply to normal preventative maintenance, maintenance or adjustments deemed appropriate by A.C. Dispensing Inc.

**THIS WARRANTY WILL BE NULL AND VOID IF THE WARRANTY REGISTRATION CARD IS NOT RETURNED TO
A.C. DISPENSING EQUIPMENT INC. WITHIN 60 DAYS OF PURCHASE.**

This warranty is subject to the following conditions:

- This warranty applies to the original owner only and is not assignable.
- Only pre-authorized service agencies directed by A.C. Dispensing Equipment Inc. are to be utilized.
- Should any product fail to function in its intended manner under normal use within the limits defined in this warranty, at the option of A.C. Dispensing Equipment Inc., such product will be repaired or replaced by A.C. Dispensing Equipment Inc. or its Authorized Service Agency. A.C. Dispensing Equipment Inc. will be responsible only for charges incurred or service performed by its Authorized Service Agencies. The use of other than A.C. Dispensing Equipment Inc. Authorized Service Agencies will void this warranty and A.C. Dispensing Equipment Inc. will not be responsible for such work or any charges associated with such work. The closest A.C. Dispensing Equipment Inc. Authorized Service Agency must be used and must be dispatched by A.C. Dispensing Equipment Inc.

TIME PERIOD:

One year on parts and labour, effective from the date of purchase. The Authorized Service Agency may, at its option, require proof of purchase. Parts replaced under this Warranty are warranted for the unexpired portion of the original product warranty only.

24-hour Toll-Free Service is available at **1-888-777-9990 or 1-902-865-9602**

A service consultant is available to assist you during our normal business hours. All service-related issues will be addressed by a return telephone call the next business day.

WARRANTY PROCEDURE:

1. Secure the Serial Number, Model Number and Option Code from the data label located on the outside of the equipment.
2. Call the number provided on the service label on the dispenser.
3. Our Technical Assistance Center staff will discuss the issue with you and, if necessary, dispatch a technician to your location for repairs. If after-hours or emergency service is required, A.C. Dispensing Equipment Inc. will not be responsible for any additional charges.
4. To order parts, call the service center and the appropriate parts will be sent to your location or that of the servicing agency.

The following conditions are not covered by this Warranty:

- Equipment failure related to improper installation, improper utility connection or supply or problems due to ventilation.
- Equipment that has not been properly maintained, calibration of controls, adjustments, damage from improper cleaning and water damage to controls.
- Equipment that has not been used in an appropriate manner or has been subject to misuse or misapplication, neglect, abuse, accident, alteration, negligence, damage during transit, delivery or installation, fire, flood, riot or act of God.
- Equipment on which the model number or serial number has been removed or altered.

If the equipment has been changed, altered, modified or repaired by other than a qualified service technician during or after the warranty period, then the manufacturer shall not be liable for any damages to any person or to any property which may result from the use of the equipment thereafter.

This Warranty does not cover services performed at overtime or premium labour rates. Should service be required at times which normally involve overtime or premium labour rates, the owner shall be charged for the difference between normal service rates and such premium rates. A.C. Dispensing Equipment Inc. does not assume any liability for extended delays in replacing or repairing any items beyond its control.

In all cases, the use of other than A.C. Dispensing Equipment Inc. authorized OEM replacement parts will void this Warranty.

This equipment is intended for commercial use only. Warranty is void if equipment is installed in other than commercial applications.

THE FOREGOING WARRANTY IS IN LIEU OF ANY AND ALL OTHER WARRANTIES EXPRESSED OR IMPLIED, INCLUDING ANY IMPLIED WARRANTY OF MERCHANTABILITY OR FITNESS AND CONSTITUTES THE ENTIRE LIABILITY OF A.C. DISPENSING EQUIPMENT INC. IN NO EVENT DOES THE LIMITED WARRANTY EXTEND BEYOND THE TERMS STATED HEREIN.

A.C. Dispensing Equipment Inc.
100 Dispensing Way
Lower Sackville
Nova Scotia, Canada B4C 4H2
1-888-777-9990 or 1-902-865-9602
www.sureshotdispensing.com



04/10/2012



A.C. Dispensing Equipment Inc.
100 Dispensing Way
Lower Sackville
Nova Scotia, Canada B4C 4H2
1-888-777-9990 or 1-902-865-9602
www.sureshotdispensing.com