



Manuale per il Tecnico  
Manual for Technical

OPERA

CE



**Italiano** .....



**English**.....





## INDEX

|  |           |
|--|-----------|
| <b>1. Introduction.....</b>  | <b>3</b>  |
| <b>2. Removing the tray .....</b>  | <b>4</b>  |
| <b>3. Removing the heating cup.....</b>  | <b>5</b>  |
| <b>4. Removing the side panels .....</b>   | <b>6</b>  |
| <b>5. Removing the rear panel.....</b>   | <b>7</b>  |
| <b>6. Layout of main components.....</b>   | <b>8</b>  |
| <b>7. Electric panel .....</b>   | <b>11</b> |
| 7.1 First machine version .....  | 11        |
| 7.1.a Layout of components.....  | 11        |
| 7.2 New machine version .....  | 12        |
| 7.2.a Layout of right-hand side components .....                                       | 12        |
| 7.2.b Layout of left-hand side components .....  | 13        |
| <b>8. Adjustments - Resets .....</b>   | <b>14</b> |
| 8.1 Adjusting mixed hot and cold water.....  | 14        |
| 8.2 Bleeding the air from the circuit.....   | 14        |
| 8.3 Resetting the service boiler safety thermostat .....                               | 14        |
| 8.4 Resetting the coffee boiler safety thermostat.....                                 | 15        |
| <b>9. Removals - Replacements .....</b>  | <b>15</b> |
| 9.1 Replacing the heating cup heating element .....                                    | 15        |
| 9.2 Replacing the service boiler heating element.....                                  | 16        |
| 9.3 Replacing the coffee boiler heating element .....                                  | 17        |
| 9.4 Replacing the pump .....   | 18        |
| 9.5 Replacing the service boiler filling solenoid valve .....                          | 20        |
| 9.6 Replacing the cold water dispensing solenoid valve for mixing with hot water ..... | 20        |
| 9.7 Replacing the hot water dispensing solenoid valve.....                             | 21        |
| 9.8 Replacing the coffee boiler draining and unit draining solenoid valves .....       | 22        |
| 9.9 Replacing the Bluetooth connection device .....                                    | 24        |
| 9.10 Removing the head and gaskets.....  | 24        |
| 9.11 Replacing the coffee unit solenoid valve .....                                    | 25        |
| 9.12 Removing the coffee unit display .....  | 26        |
| 9.13 Removing the coffee unit pushbutton panel .....                                   | 27        |
| 9.14 Replacing the coffee unit heating element, sensor and thermostat .....            | 29        |
| 9.15 Removing the joystick .....   | 32        |
| 9.16 Removing the water unit display .....   | 35        |
| 9.17 Removing the hot water tube and water tap button.....                             | 36        |
| 9.18 Removing the steam tap .....  | 38        |
| 9.19 Replacing the safety thermostat.....  | 39        |
| 9.20 Removing the service boiler .....   | 40        |
| 9.21 Removing the coffee boiler.....   | 42        |
| 9.22 Replacing the main switch.....  | 44        |
| 9.23 Replacing the LED strip.....  | 45        |
| <b>10. Programming by the technician.....</b>  | <b>47</b> |
| 10.1 Programming from display .....  | 47        |
| 10.1.a Programmable section sequence.....  | 51        |
| 10.1.b Programming doses, time and pump power .....                                    | 62        |
| 10.2 Programming from tablet.....  | 65        |
| 10.3 Programming the units .....   | 70        |
| <b>11. OPERA 2-3 UNIT - HYDRAULIC DIAGRAM .....</b>                                    | <b>72</b> |
| <b>12. WIRING DIAGRAMS.....</b>  | <b>73</b> |
| 12.1 Wiring diagram OPERA 2-3 UNITS - SINGLE-PHASE .....                               | 73        |
| 12.2 Wiring diagram OPERA 2-3 UNITS - THREE-PHASE .....                                | 74        |



## 1. INTRODUCTION

- This manual was written only to be used by authorised technicians of the manufacturer.

### 1.1 General safety warnings

- When operating on the machine, make sure that the main switch and the machine switch are in **OFF** position and that the water supply tap is closed.
- When some operations/adjustments need to be carried out with the power on, **operate with extreme care.**
- When operating on the machine, check that the water contained in the machine is cold.
- When some operations/adjustments need to be carried out with the machine at operating temperature, **operate with extreme care** and use suitable personal protective equipment.
- Suitable personal protective equipment must be worn in any case as required by current safety regulations in the country of use.
- Current specific regulations in the country of use must be followed at all times.
- See the attached wiring diagram for all operations on the electrical system.
- See the attached water diagram for all operations on the water system.

## 2. REMOVING THE TRAY



- Remove the grille (1).

- Undo the two Allen screws (2).



2



3

- Pull the tray (3) forward to slide out the coupling (4) and remove it.

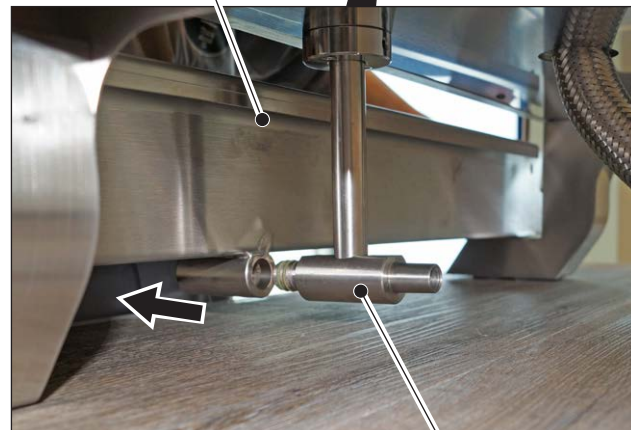

4

 When refitting the tray (3), check the condition of the O-rings (5) and grease them.

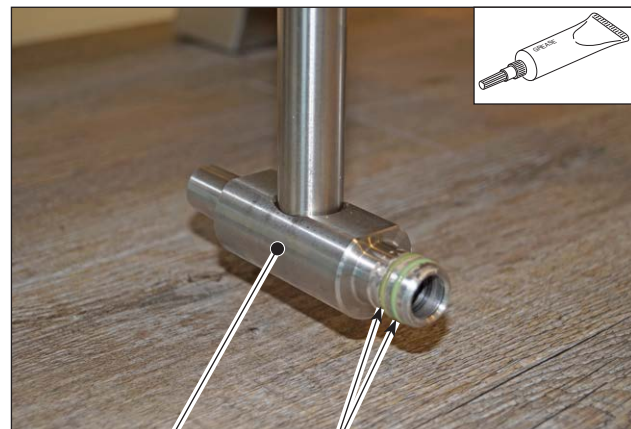

4

5

### 3. REMOVING THE HEATING CUP

- Undo the four screws (1).

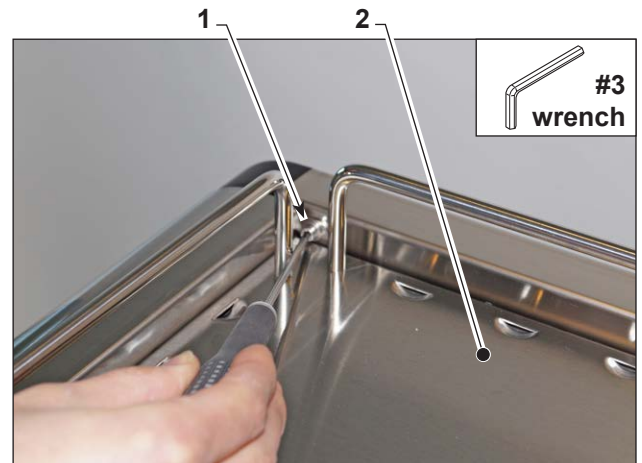
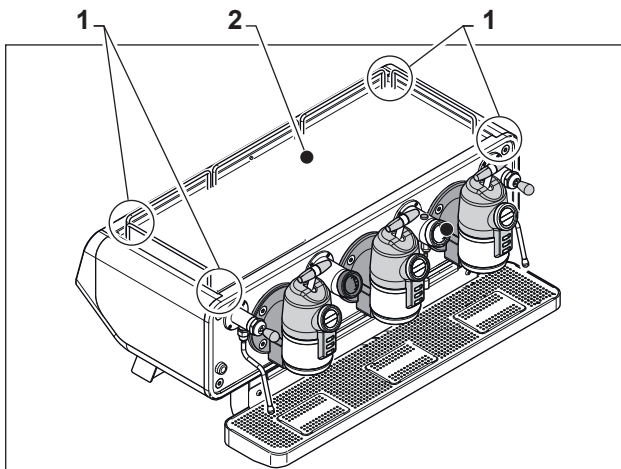

- Lift the heating cup (2).

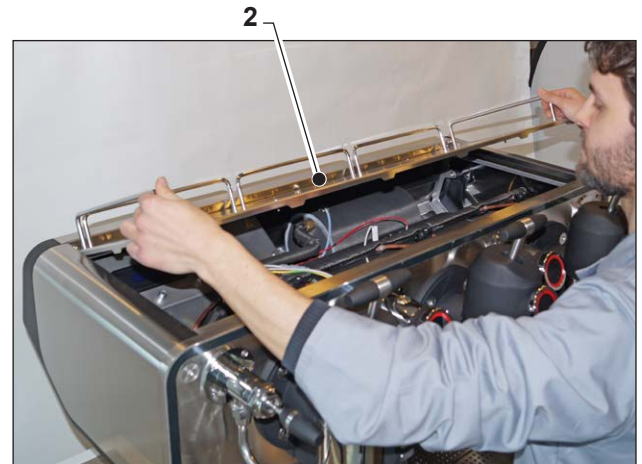

- Disconnect the connector (3).

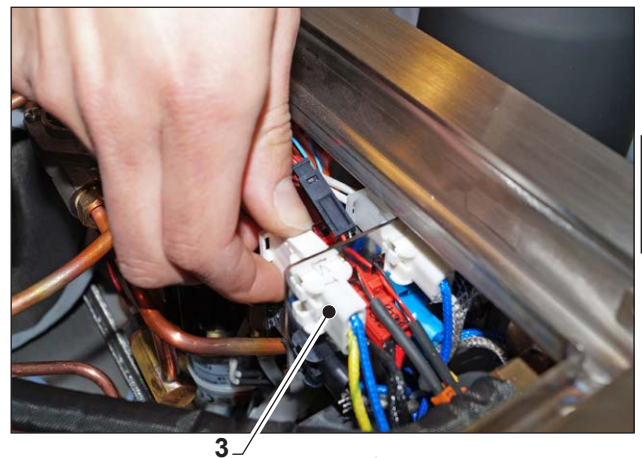

- Remove the heating cup (2).

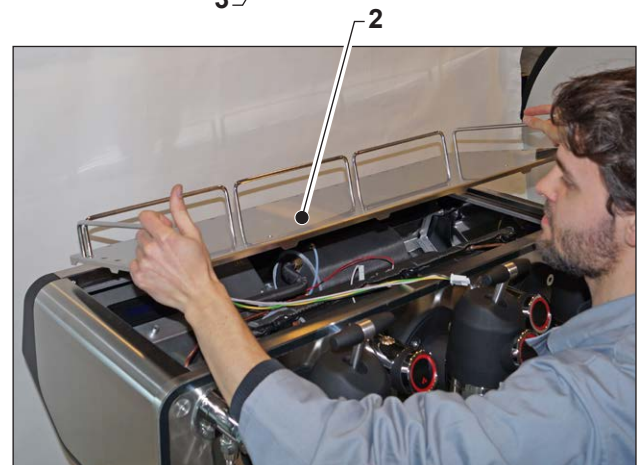

EN

#### 4. REMOVING THE SIDE PANELS

- Push the lower part of the side panel (1) from the

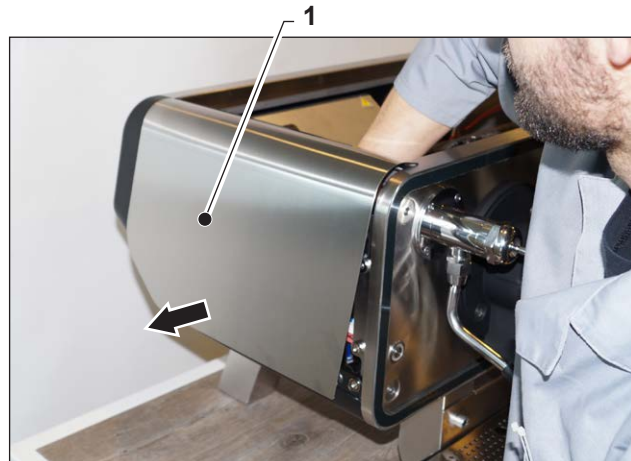

inside to the outside.

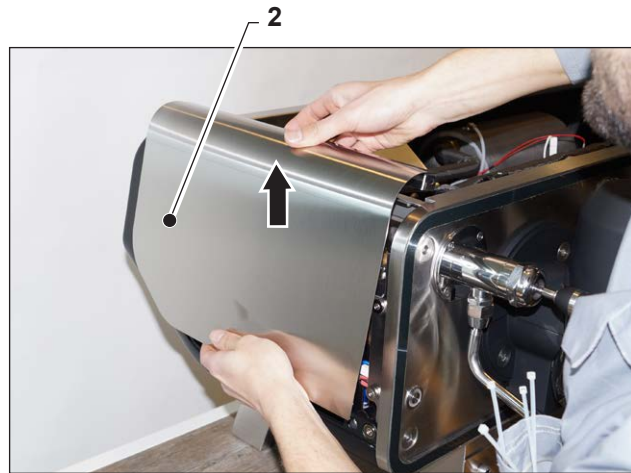

- Lift the side panel (2) to remove it.
- Carry out the same operations to remove the other side panel.

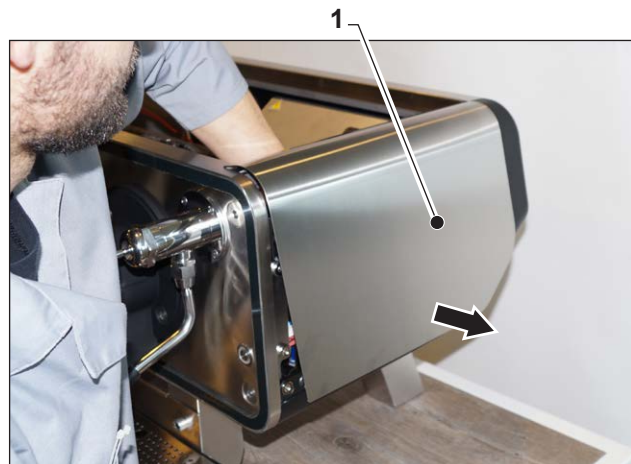

EN

 **Remove the side panels and the heating cup to access all the internal machine components.**



### 5. REMOVING THE REAR PANEL

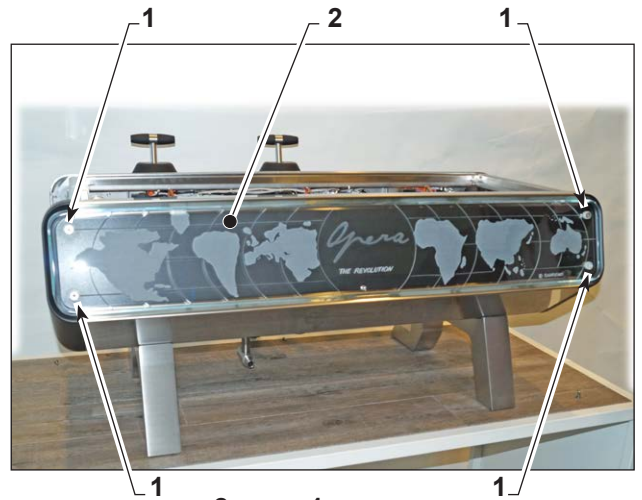

- Undo the four screws (1) and remove the glass panel (2).

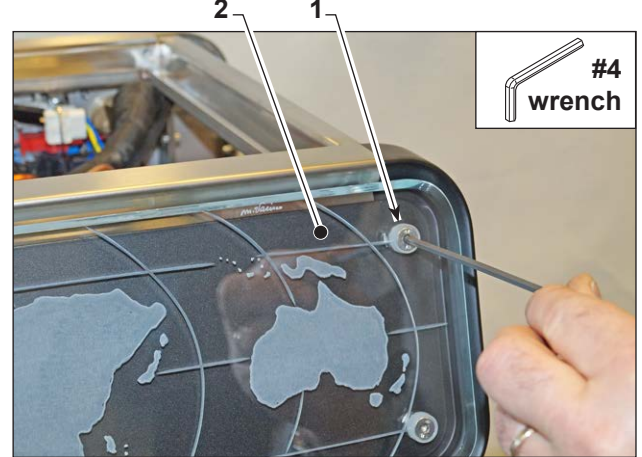

- Remove the spacers (3).



- Remove the rear panel (4).

>>>>

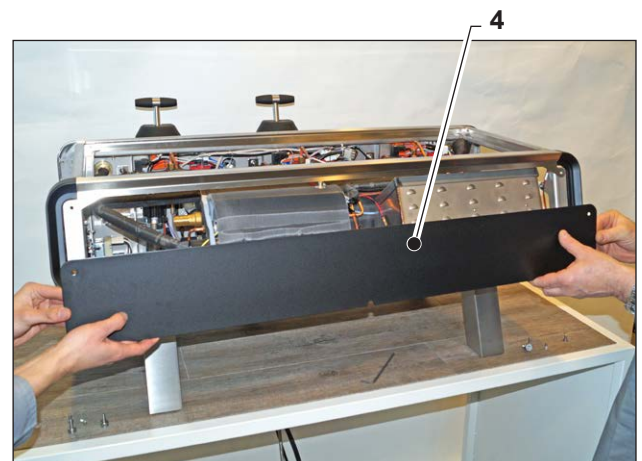

EN



When refitting the glass panel (2), check that the spacers (3) and the inserts are in place (5).

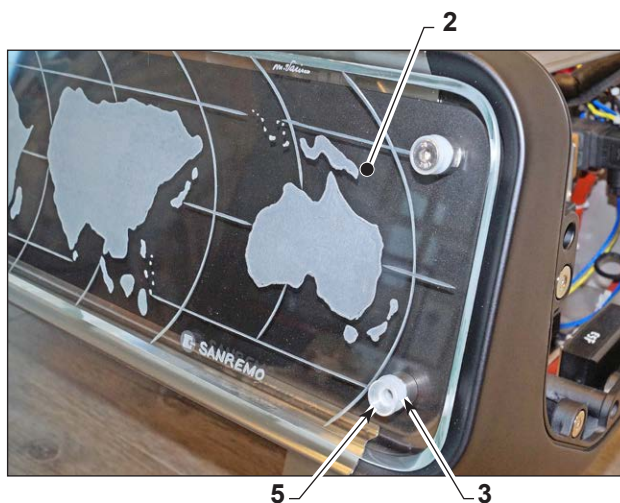

## 6. LAYOUT OF MAIN COMPONENTS

(pages 9/74 and 10/74)

### 7.1. Top view

- 1) Unit "1" small boiler steam tap.
- 2a) Unit "1" coffee dispensing.
- 2b) Unit "2" coffee dispensing.
- 2c) Unit "3" coffee dispensing.
- 3) Water tap button.
- 4a) Unit "1" displacement counter.
- 4b) Unit "2" displacement counter.
- 4c) Unit "3" displacement counter.
- 5a) Unit "1" pump.
- 5b) Unit "2" pump.
- 5c) Unit "3" pump.
- 6) Service boiler filling solenoid valve.
- 7a) Coffee boiler draining solenoid valve.
- 7b) Unit draining solenoid valve.
- 8) Bluetooth connection device.
- 9) Air bleeding button.
- 10) Display.
- 11a) Cold water dispensing solenoid valve for mixing with hot water.
- 11b) Hot water dispensing solenoid valve.
- 12) Electrical component panel.
- 13) Coffee boiler.
- 14) Service boiler.
- 15) LED strip.
- 16) Coffee boiler safety thermostat.
- 17) Service boiler safety thermostat.
- 18) ON/OFF switch.

2 Unit version

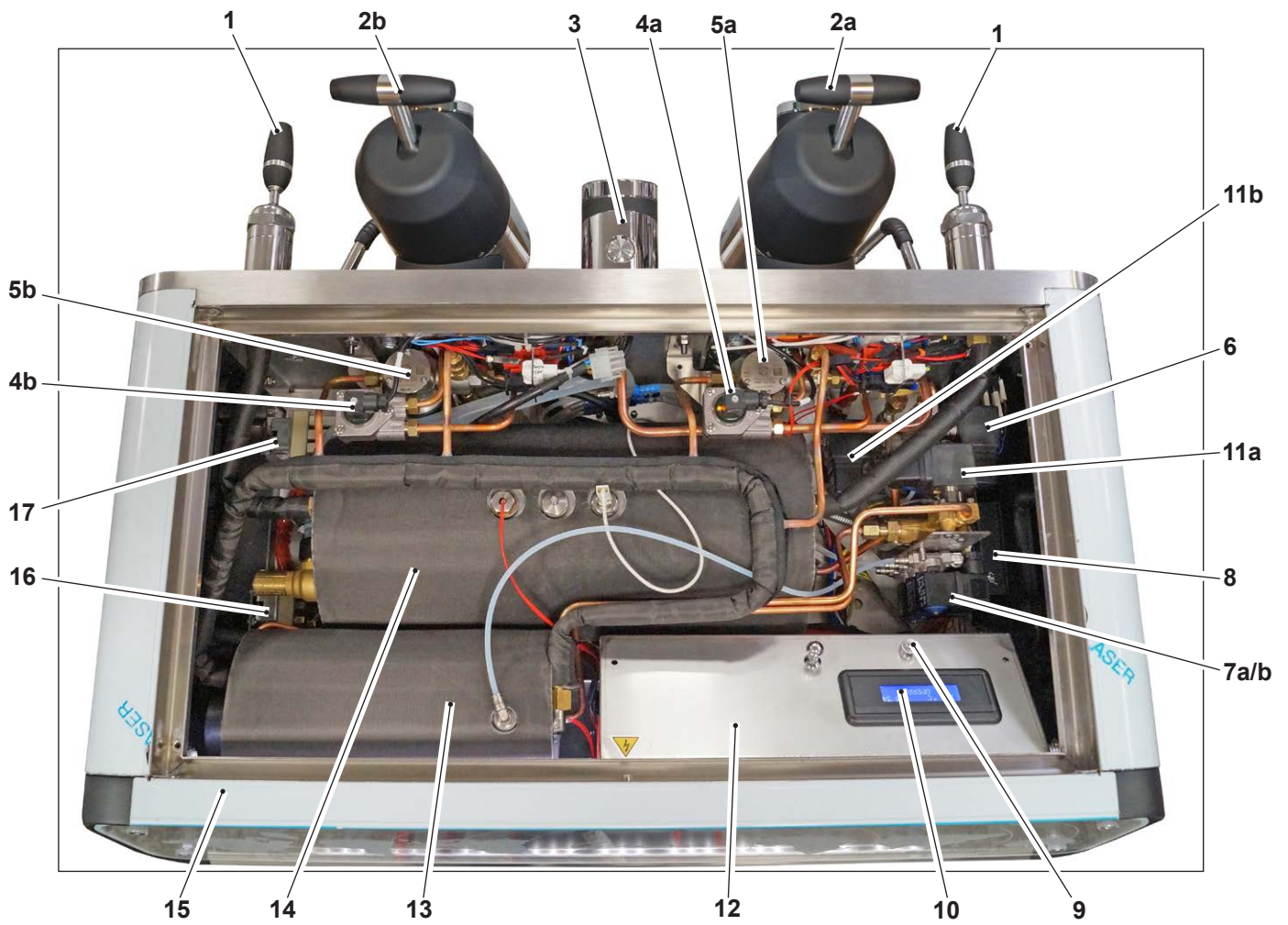

3 Unit version

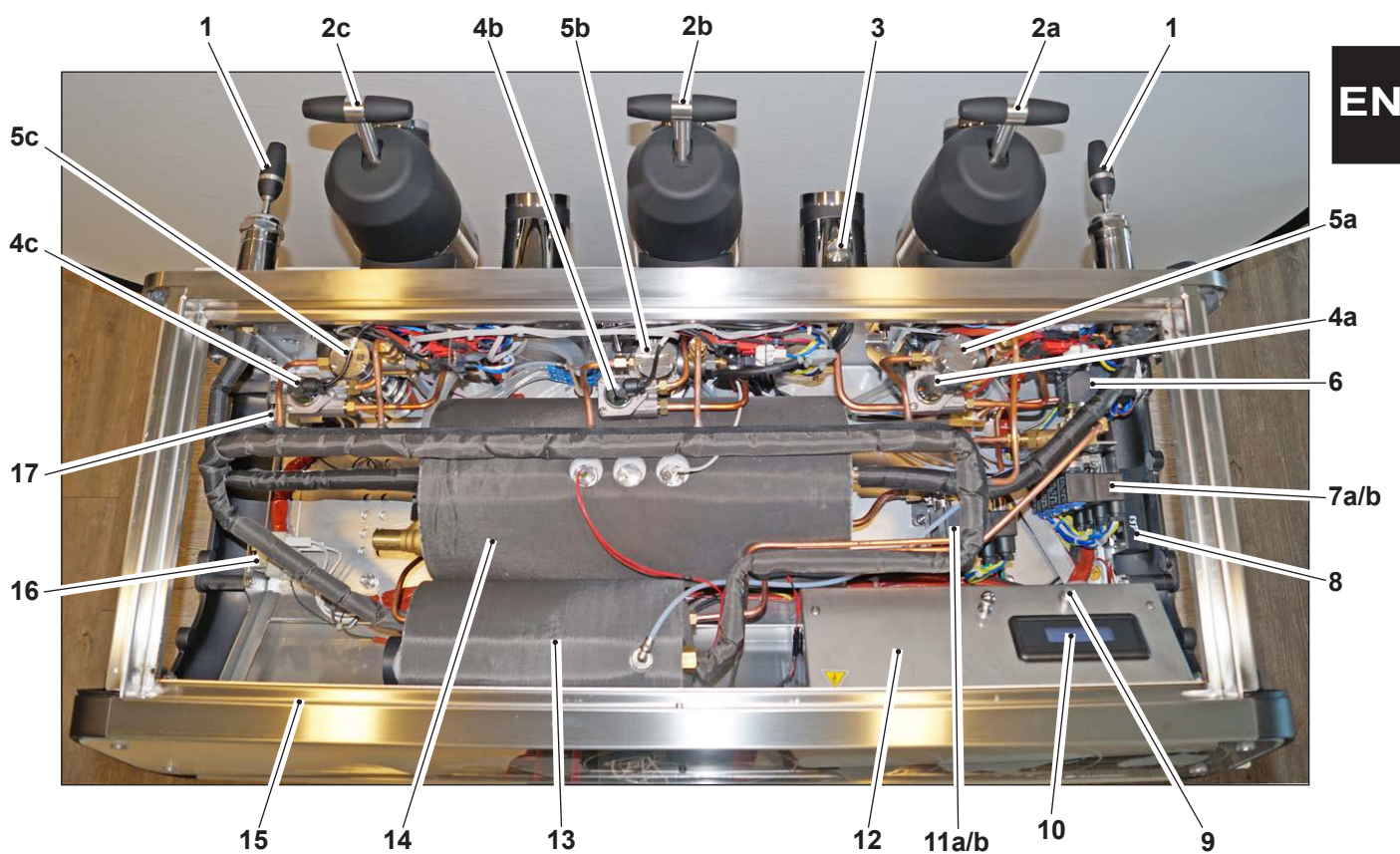

EN

LH side of the machine

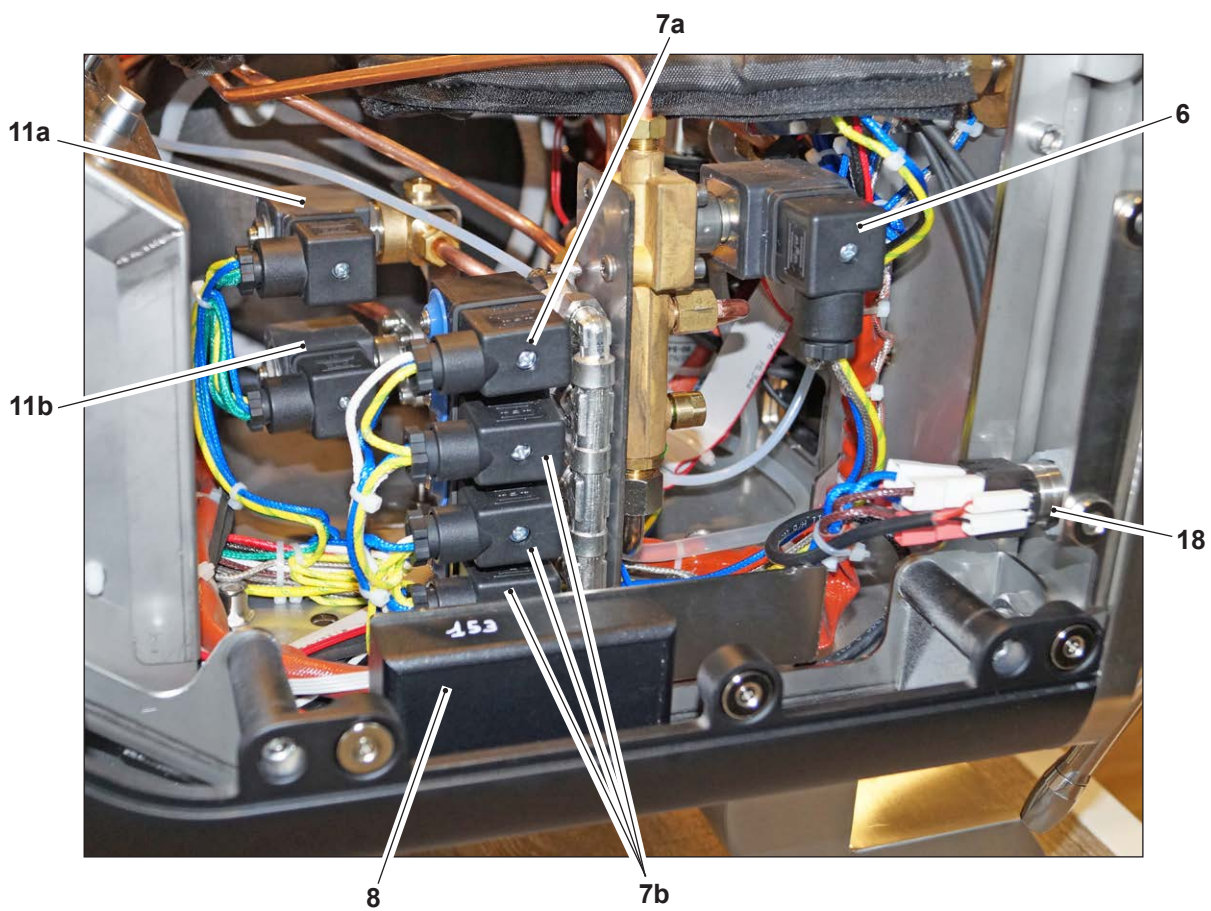

Front of the machine



EN

## 7. ELECTRICAL PANEL

### 7.1 First machine version

- Remove the heating cup (1) as described in the relative paragraph.
  
- Unscrew the two screws (2) and remove cover (3) to access the internal components.

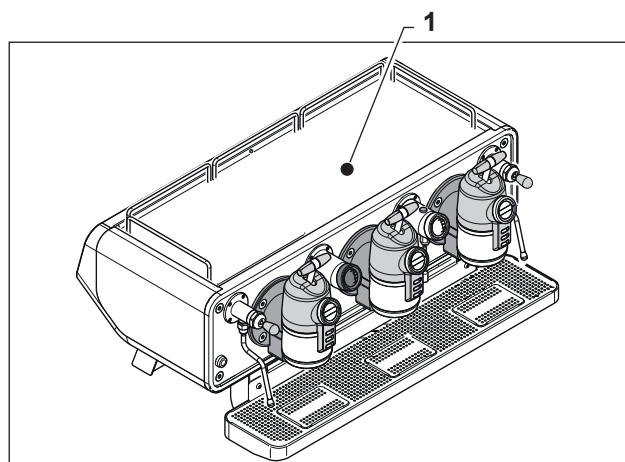

#### 7.1.a Layout of components

- 3) Cover.
- 4) Air bleeding button.
- 5) Display.
- 6) Control unit board.
- 7) CR 2032 memory battery.
- 8) 5A fuse.
- 9) Switch board.
- 10) Remote control switch.
- 11) Three-phase static relay.
- 12) Single-phase static relay.
- 13) Triac expansion board.

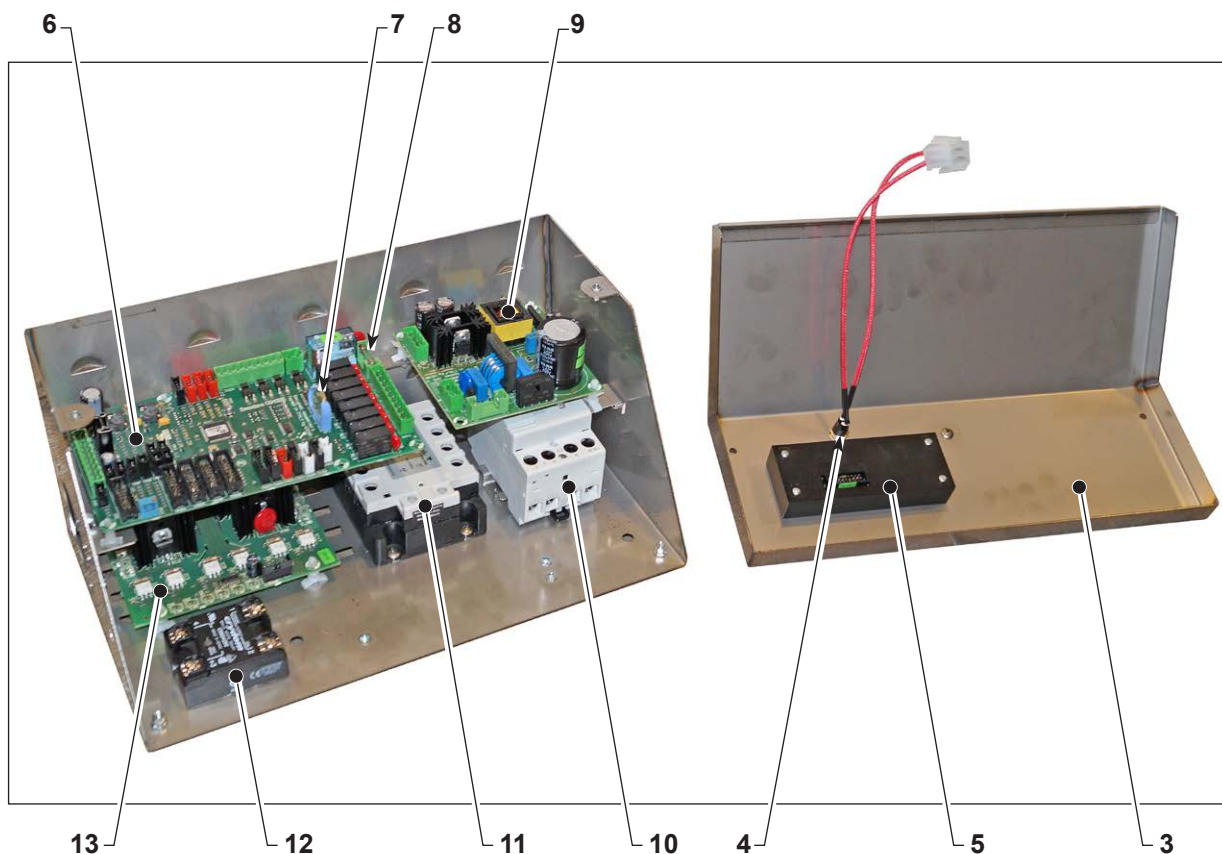
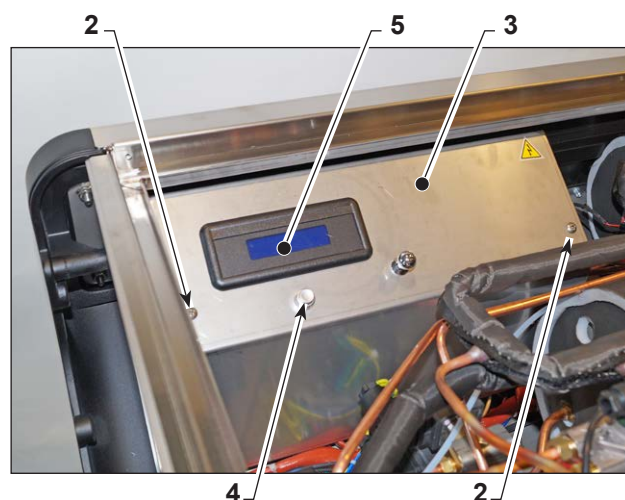

EN

### 7.2 New machine version

The electrical components are positioned under the side panels.

- Remove the RH (1) and LH (2) side panels as described in the relative paragraph to access the electrical components.

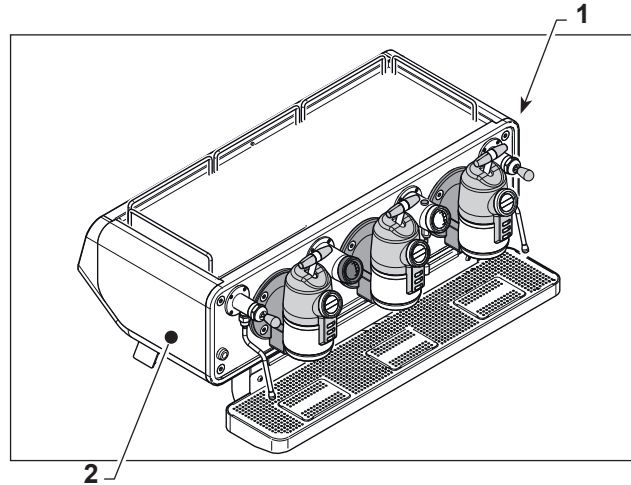

- The electric panels are hinged. To open them, undo the relative screw (3).

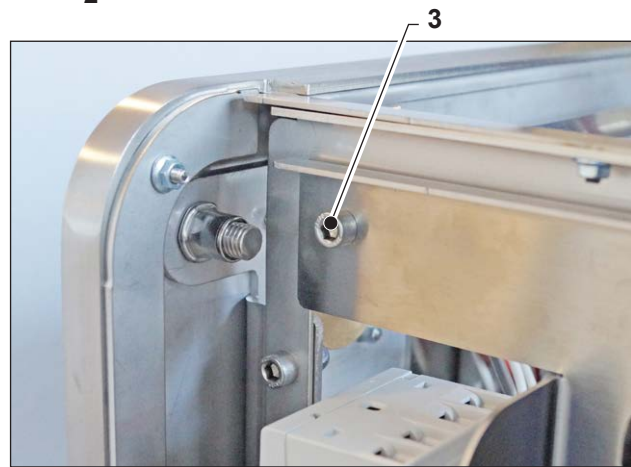

#### 7.2.a Layout of right-hand side components

- 4) Remote control switch.
- 5) Single-phase static relay.
- 6) Three-phase static relay.
- 7) Control unit transformer.

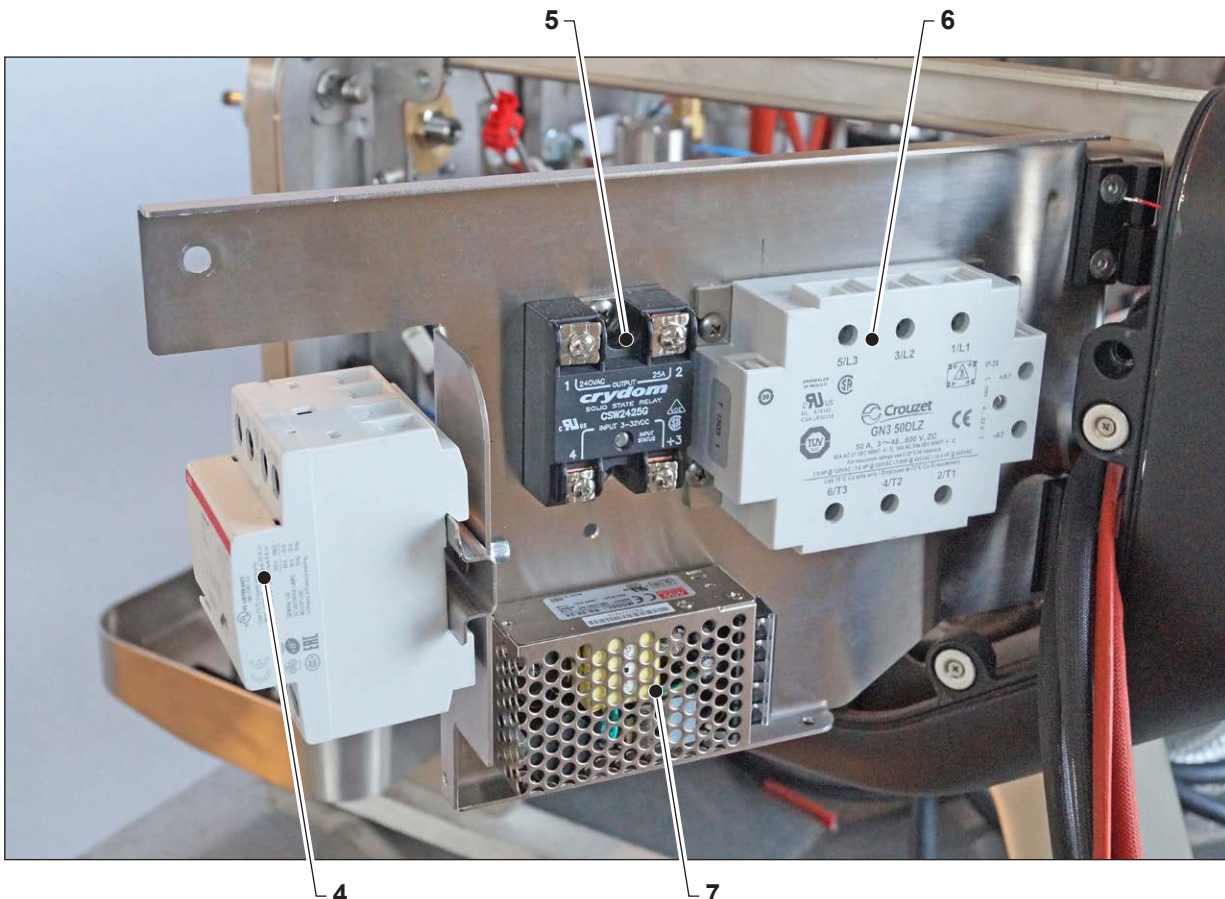

EN

7.2.b Layout of left-hand side components

- 8) Control unit board.
- 9) CR 2032 memory battery.
- 10) 5A fuse.
- 11) Pump and lights transformer (switching power supply).
- 12) Triac expansion board.
- 13) Pump 1 (P1) 1,25A protection fuse.
- 14) Pump 2 (P2) 1,25A protection fuse.
- 15) Control unit (C) 1A protection fuse.
- 16) LED strip 1A protection fuse.
- 17) Pump 3 (P3) 1,25A protection fuse.

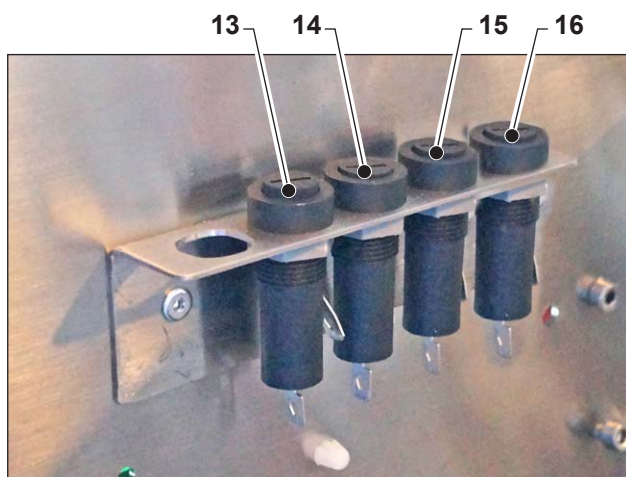
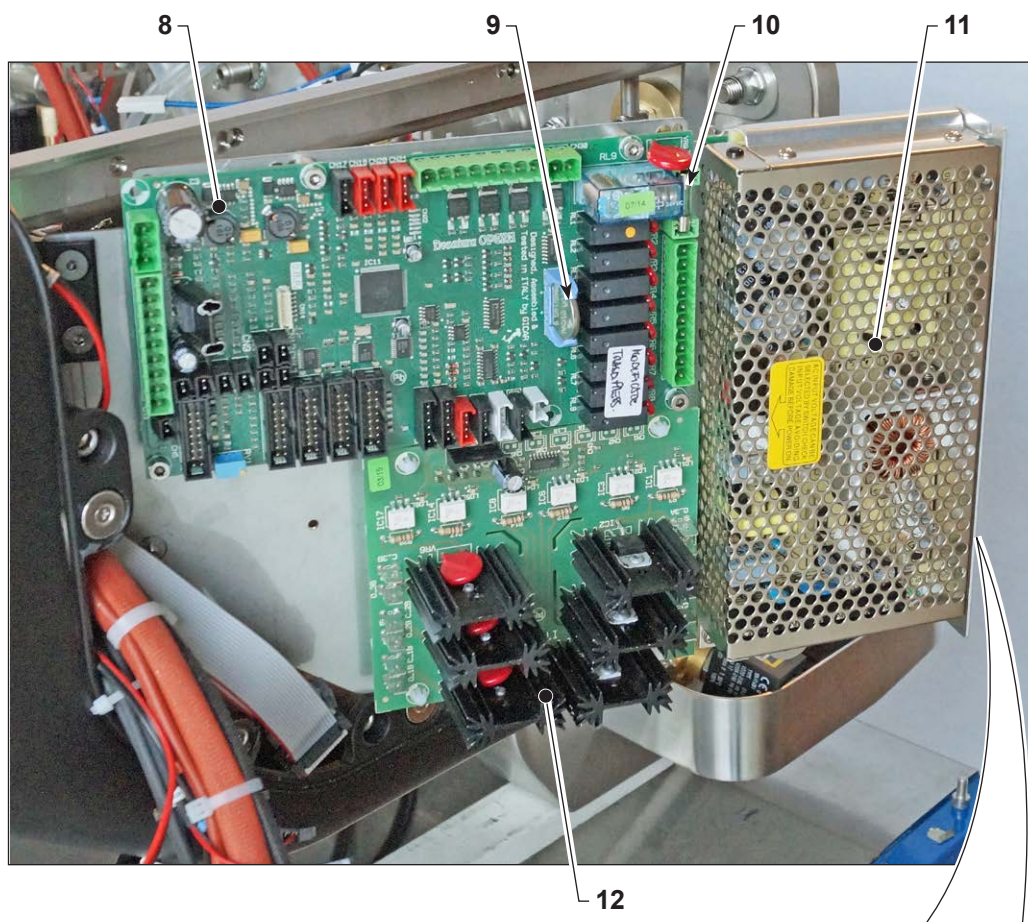

2 Unit version



3 Unit version

EN

## 8. ADJUSTMENTS - RESETS

### 8.1 Adjusting mixed hot and cold water

- Remove the heating cup as described in the relevant paragraph.
- Act on the screw (1) of the solenoid valve (2) to adjust the amount of cold water that is mixed with hot water during water dispensing.

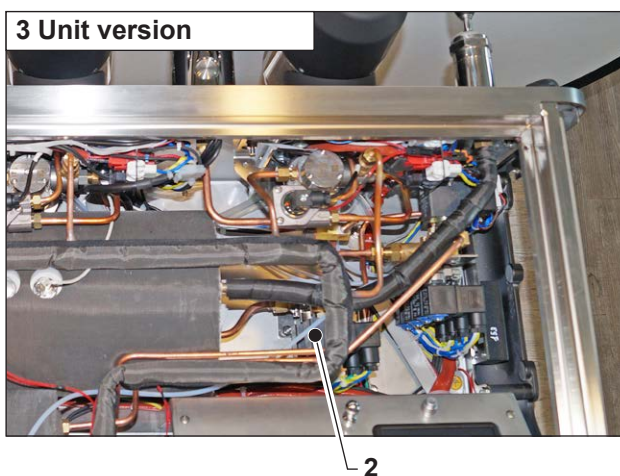
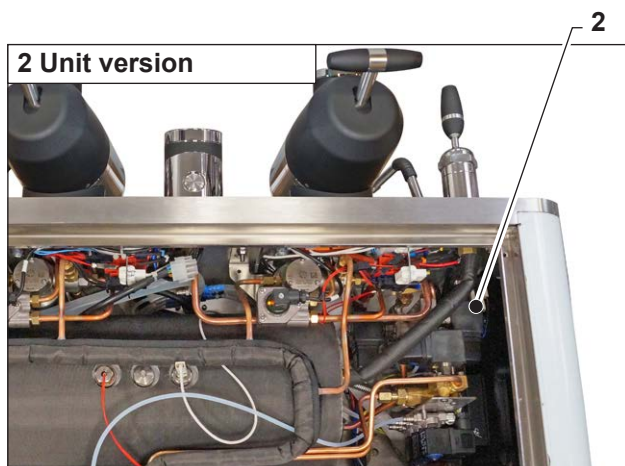
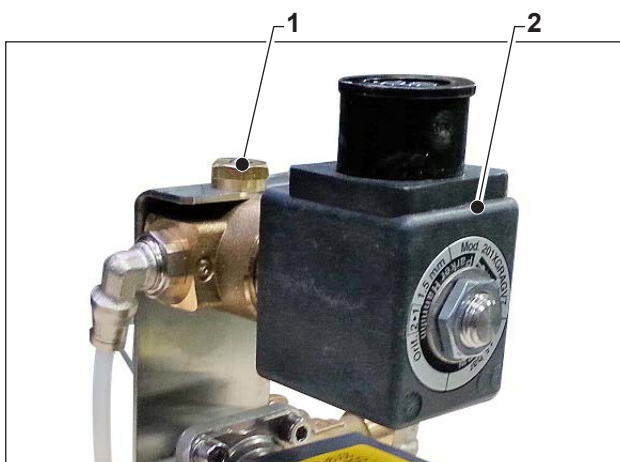

### 8.2 Bleeding the air from the circuit

- Remove the heating cup as described in the relevant paragraph.
- Press the button (1) to excite the four coils (2 and 3) and bleed any air from the circuit.

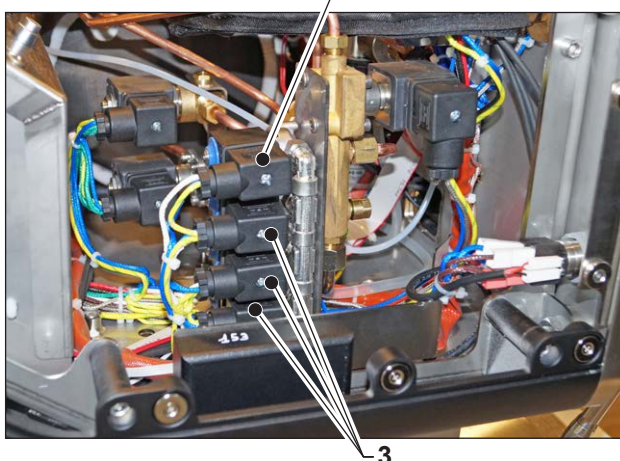
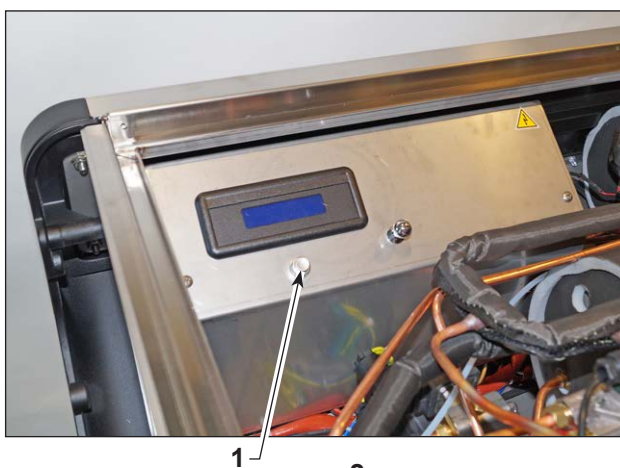

EN

### 8.3 Resetting the service boiler safety thermostat

- Remove the heating cup as described in the relevant paragraph.
- Remove the RH side panel as described in the relative paragraph.
- Press the safety thermostat (1a) to reset it.

 **If the thermostat trips again when the machine is restarted after resetting the safety thermostat, check the boiler heating elements and the other thermostats in the machine.**

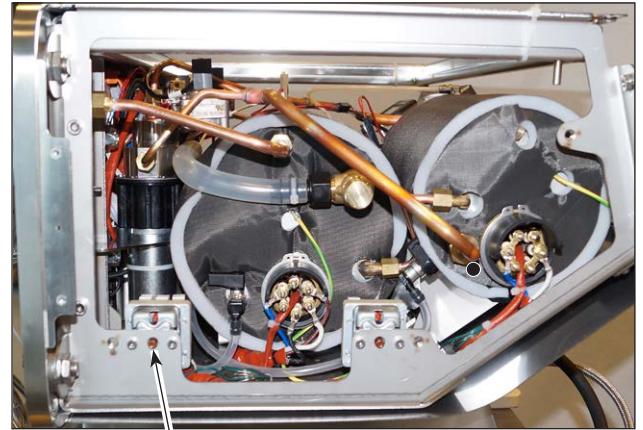

1a

### 8.4 Resetting the coffee boiler safety thermostat

- Remove the heating cup as described in the relevant paragraph.
- Remove the RH side panel as described in the relative paragraph.
- Press the safety thermostat (1b) to reset it.

 **If the thermostat trips again when the machine is restarted after resetting the safety thermostat, check the adjustment of the small boiler temperature thermostat or its proper functioning.**

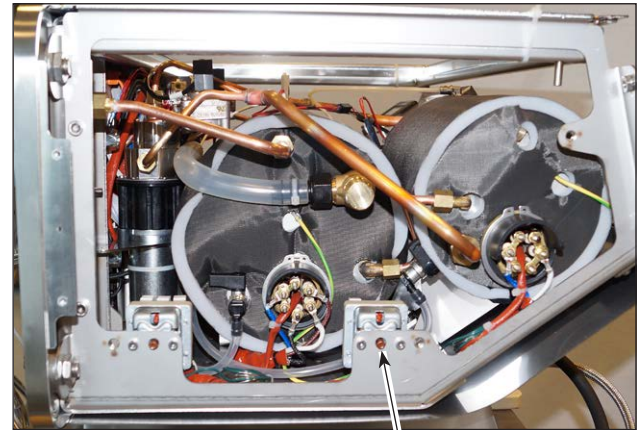

1b

EN

## 9. REMOVALS - REPLACEMENTS

### 9.1 Replacing the heating cup heating element

- Remove the heating cup (1) as described in the relative paragraph.

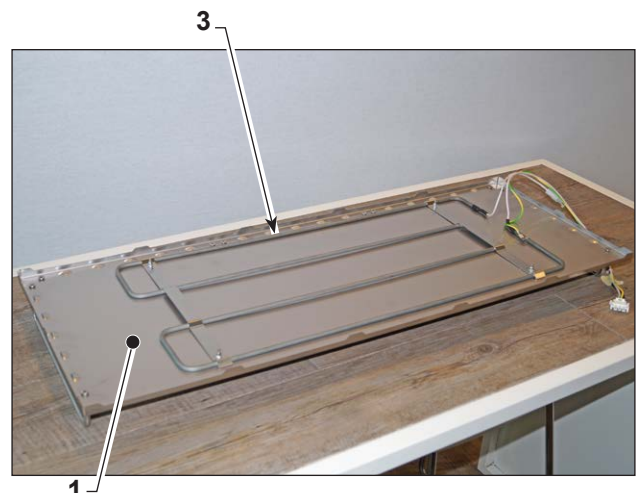

1

3

>>>>

- Remove the Faston connector (2).
- Undo the four screws (4) and the relative nuts (5).

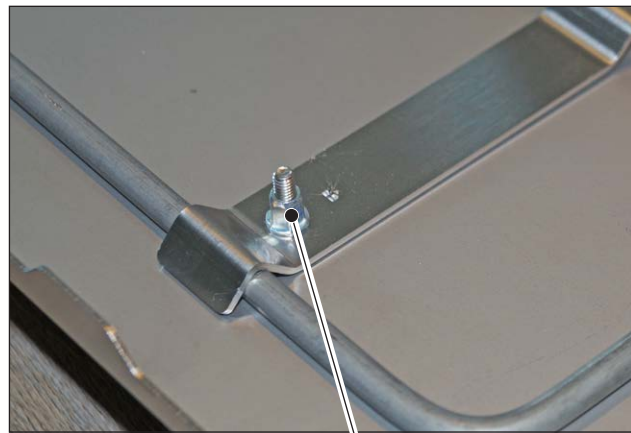
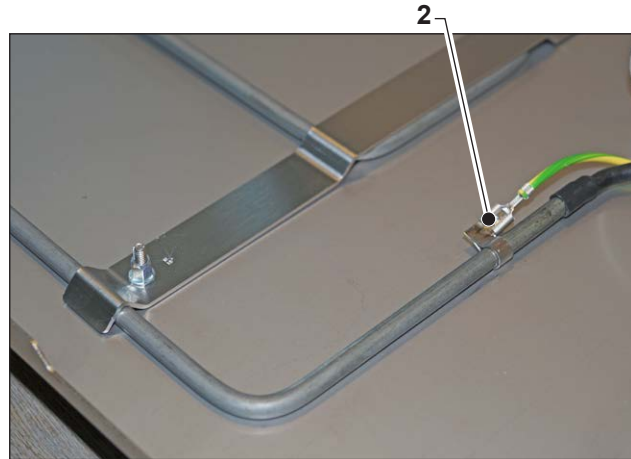

- Remove the brackets (6) and replace the heating element (3).

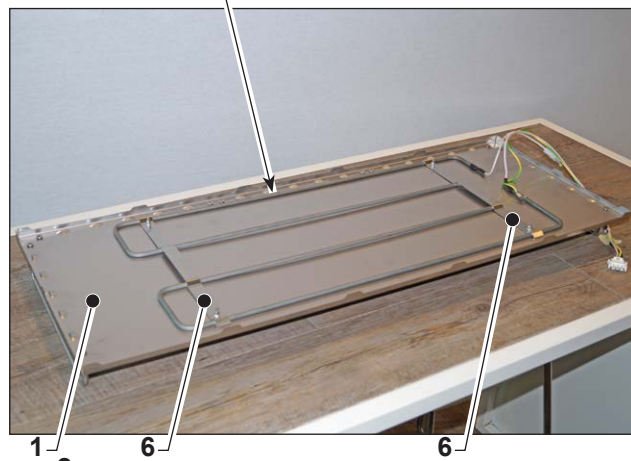

EN

## 9.2 Replacing the service boiler heating element



**Cut the power to the machine by setting the upstream main switch to OFF.**

- Remove the RH side panel as described in the relative paragraph.
- Operate on the large boiler (2).

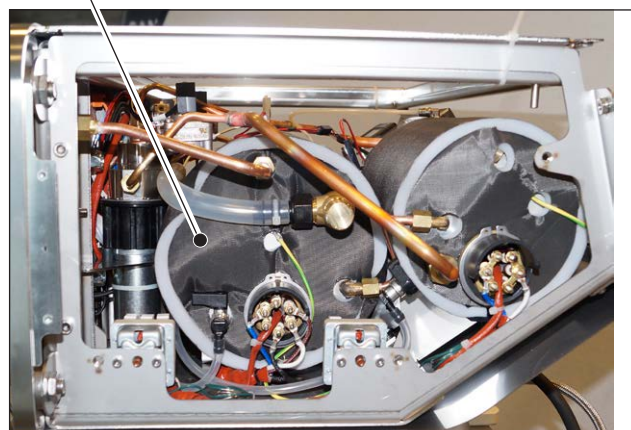

- Open the tap (1) to drain the water from the boiler (2).
- Disconnect all the wires that connect the heating element (5) to the machine wiring by unscrewing the relative nuts (6).
- Remove the Seeger ring (3) and guard (4).
- Unscrew the heating element (5) and replace it.
- Refit everything operating in reverse order from removal checking the condition of the heating element and replacing it if it is worn.
- Connect the wiring following the instructions on the wiring diagram attached to this manual.

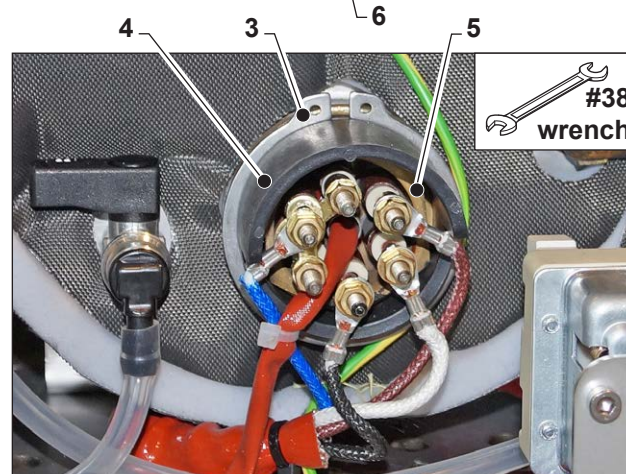
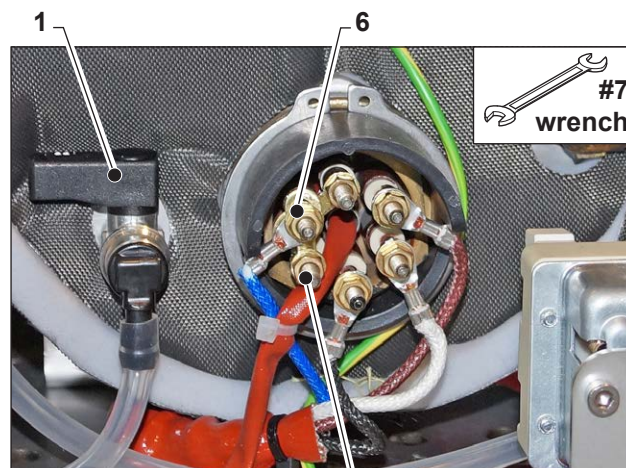

### 9.3 Replacing the coffee boiler heating element



**Cut the power to the machine by setting the upstream main switch to OFF.**

- Remove the RH side panel and lower the electric panel as described in the relative paragraph.
- Open the tap (1) to drain the water from the boiler (2).
- Disconnect all the wires that connect the heating element (5) to the machine wiring by unscrewing the relative nuts (6).

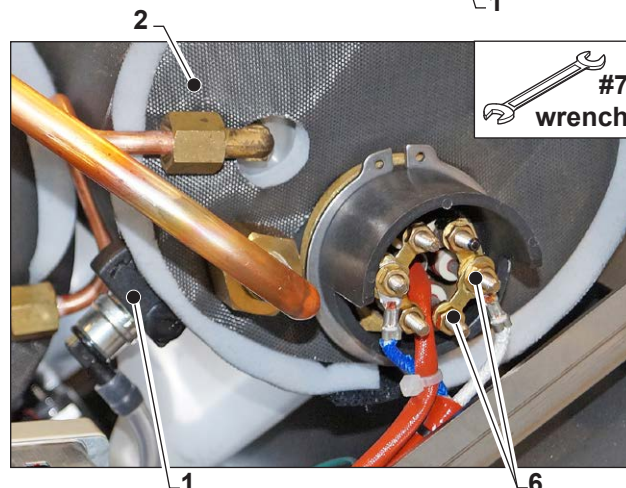
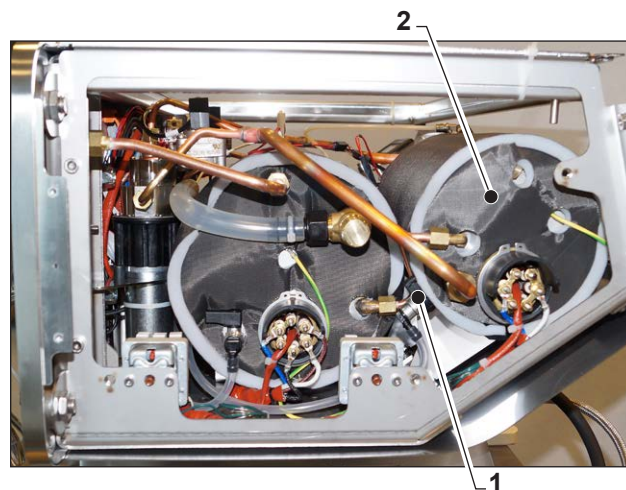

EN

- Remove the Seeger ring (3) and guard (4).
- Refit everything operating in reverse order from removal checking the condition of the heating element and replacing it if it is worn.
- Connect the wiring following the instructions on the wiring diagram attached to this manual.

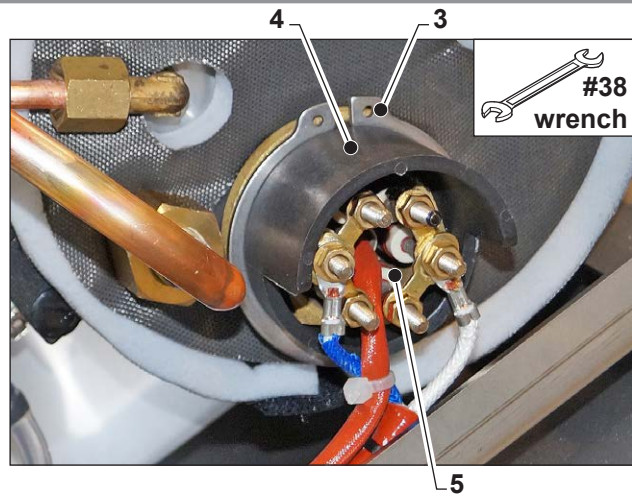

### 9.4 Replacing the pump

Each dispensing unit is equipped with a pump (1). To replace it, operate as follows (the operations are the same for all the pumps):

- Remove the heating cup as described in the relevant paragraph.
- Unscrew the union (2).
- Unscrew the union (3).

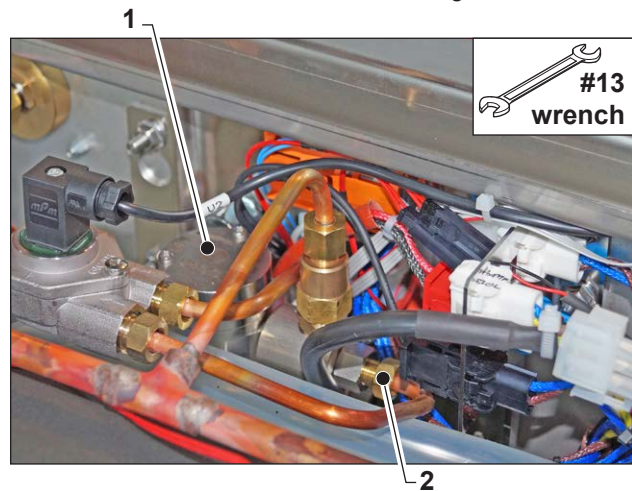

- Unscrew the union (3).

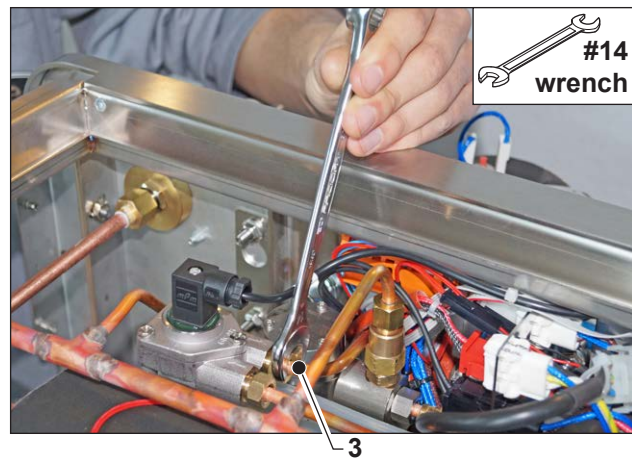

- Remove the displacement counter (4).

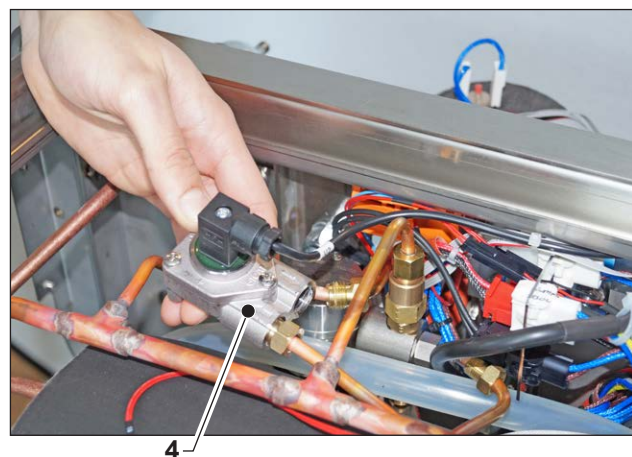

- Unscrew the upper union (5) and the side union (6).

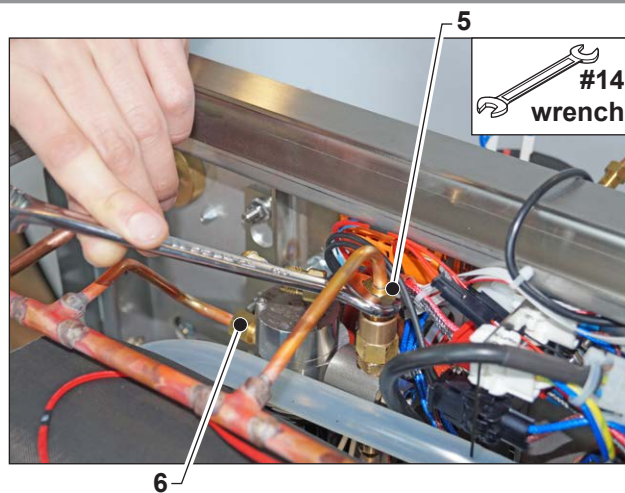

- Loosen the two nuts (7).

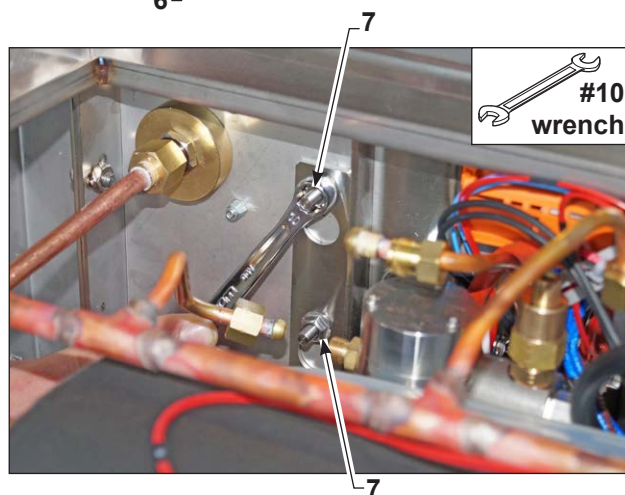

- Remove the pump (1).
- Disconnect the red connector (8).
- Disconnect the transparent tube (9).

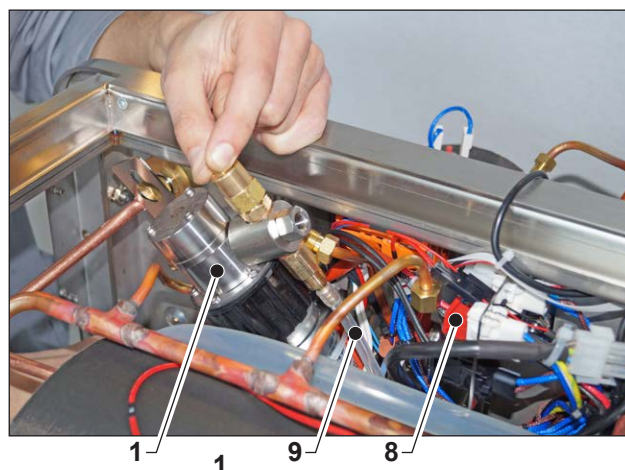

- Replace the pump (1).
- Refit everything operating in reverse order from removal.



EN

### 9.5 Replacing the service boiler filling solenoid valve

- Remove the heating cup and the LH side panel as described in the relative paragraphs.
- Unscrew the screw (1) and remove the electrical connection to the coil (2).

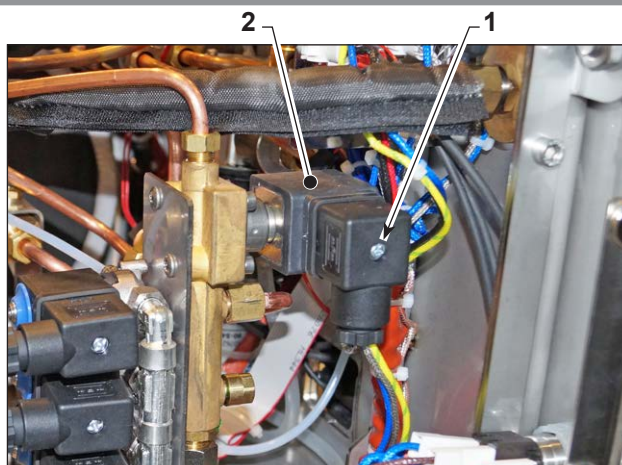

- Unscrew the nut (3) and remove the coil (2).

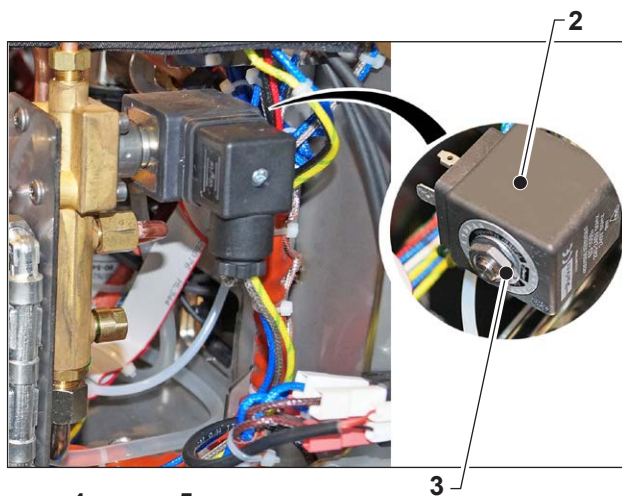

- Unscrew the four screws (4) and remove solenoid valve (5) from the body.
- Refit everything operating in reverse order from removal.

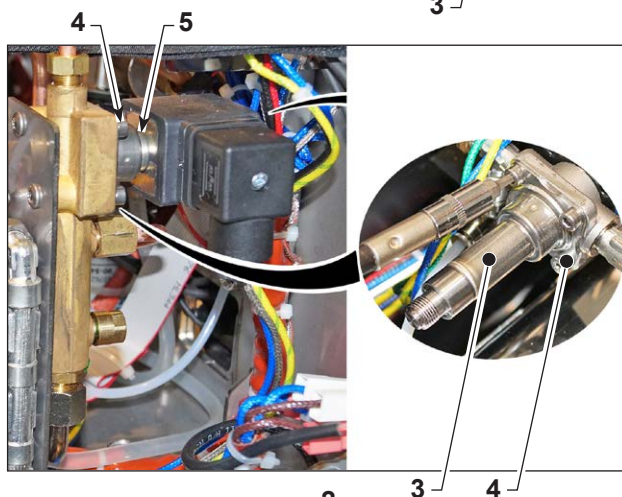

EN

### 9.6 Replacing the cold water dispensing solenoid valve for mixing with hot water

- Remove the heating cup and the LH side panel as described in the relative paragraphs.
- Operate on the solenoid valve (2).

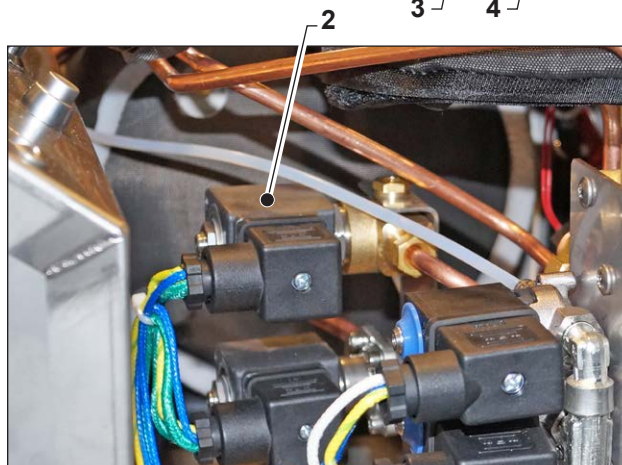

- Unscrew the screw (1) and remove the electrical connection to the coil (2).
- Unscrew the nut (3) and remove the coil (2).
- Unscrew the two side unions (4).

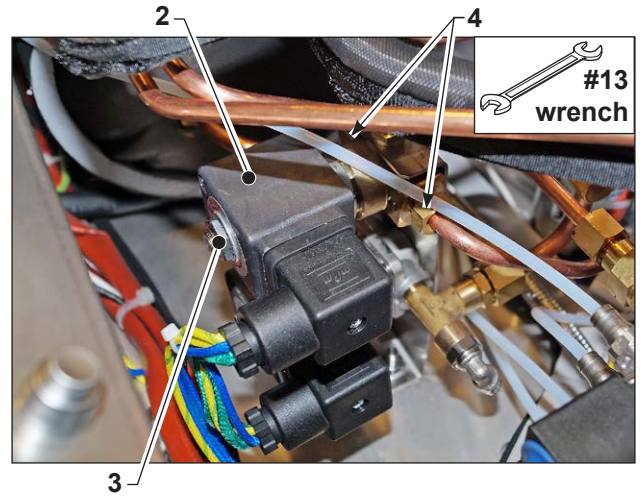

- Unscrew the upper nut (5).
- Remove the solenoid valve (6).
- Refit everything operating in reverse order from removal.

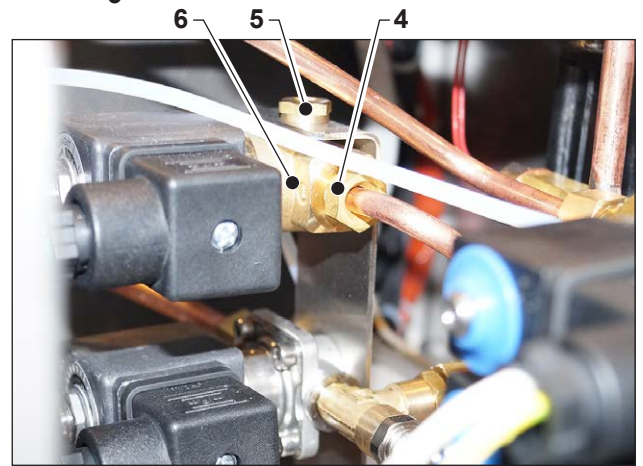

### 9.7 Replacing the hot water dispensing solenoid valve

- Remove the heating cup and the LH side panel as described in the relative paragraphs.
- Unscrew the screw (1) and remove the electrical connection to the coil (2).
- Unscrew the nut (3) and remove the coil (2).

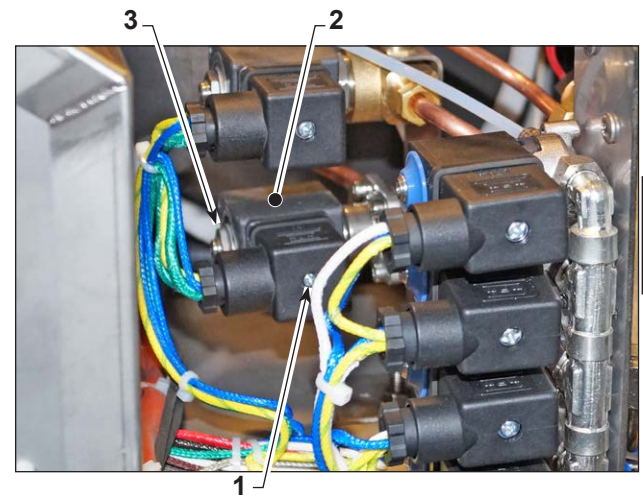

- Undo the four screws (4) and remove the solenoid valve from the body.
- Refit everything operating in reverse order from removal.

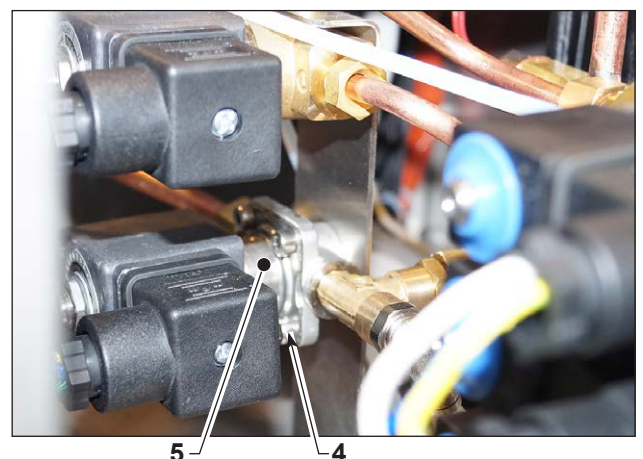

EN

### 9.8 Replacing the coffee boiler draining and unit draining solenoid valves

The operations described below are the same for the coffee boiler draining solenoid valve (1) and the unit draining solenoid valves (2).

- Remove the heating cup and the LH side panel as described in the relative paragraph.

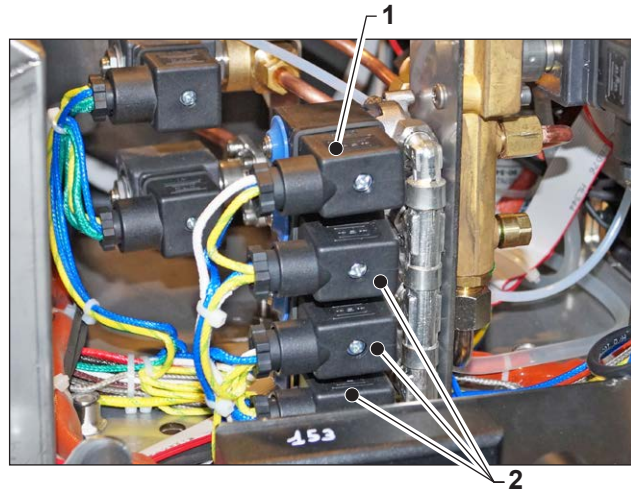

- Unscrew the screw (3) and remove the electrical connection to the coil (4).

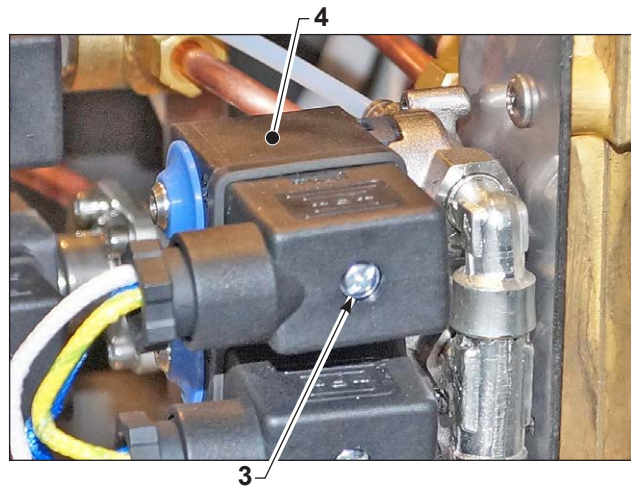

- Remove the blue cap (5).

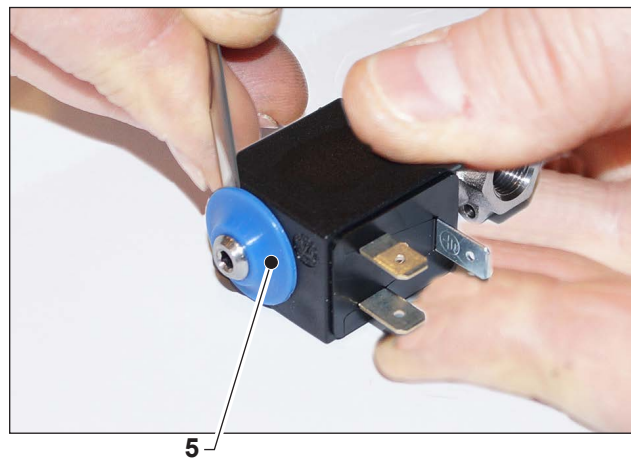

- Pull the coil (4) outward to remove it from the body (6).

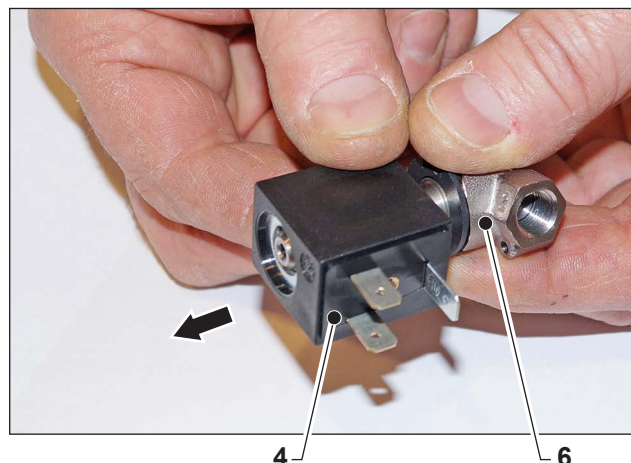

EN

- Check that the spring (7) is on the pin (8).  
Slide out the disc (9).

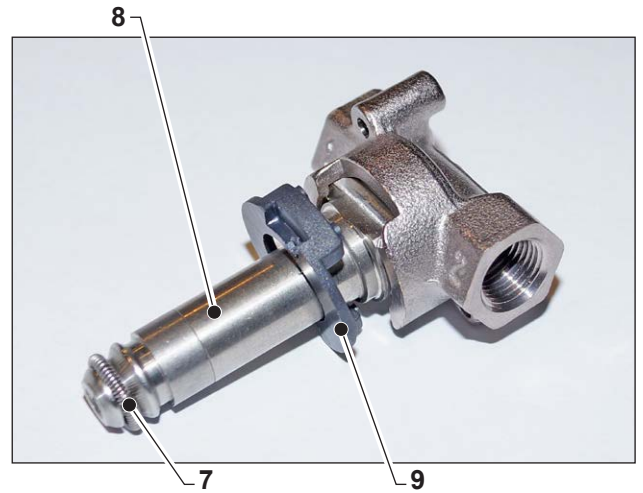

- Unscrew the unit to separate the pin (8) from the body (10).

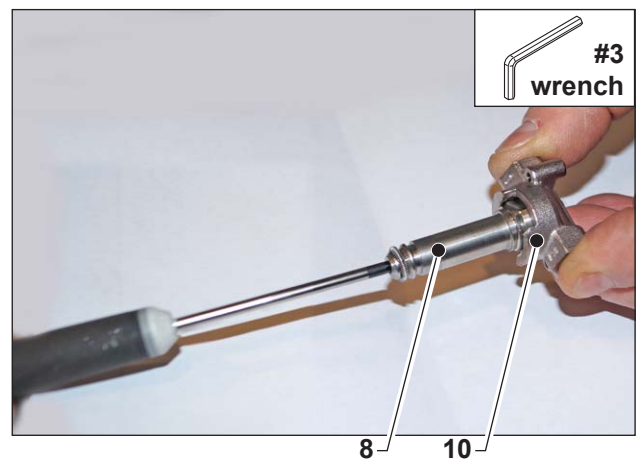

- Before refitting, check the condition of the spring (11) and the O-ring (12).
- Refit everything operating in reverse order from removal.

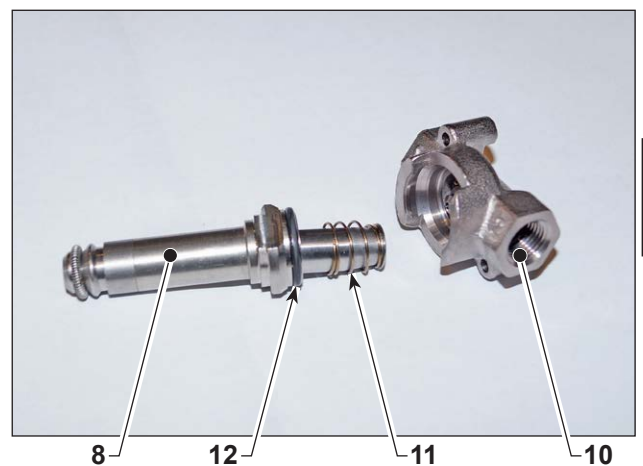

EN

### 9.9 Replacing the Bluetooth connection device

- Remove the heating cup and the LH side panel as described in the relative paragraph.
- Undo the four screws (1).
- Disconnect the connector (2).
- Remove the Bluetooth device (3).

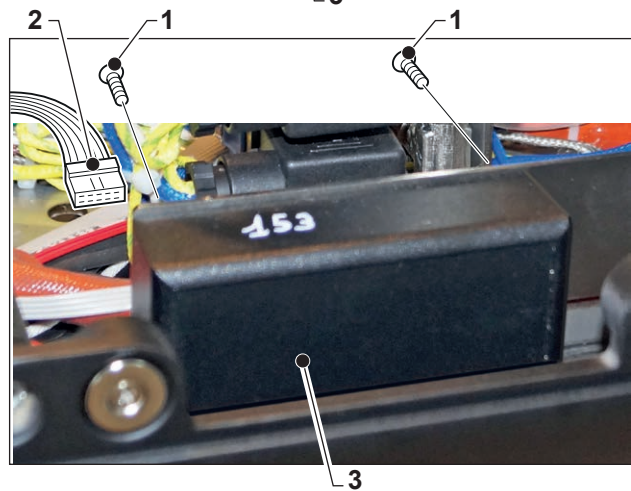
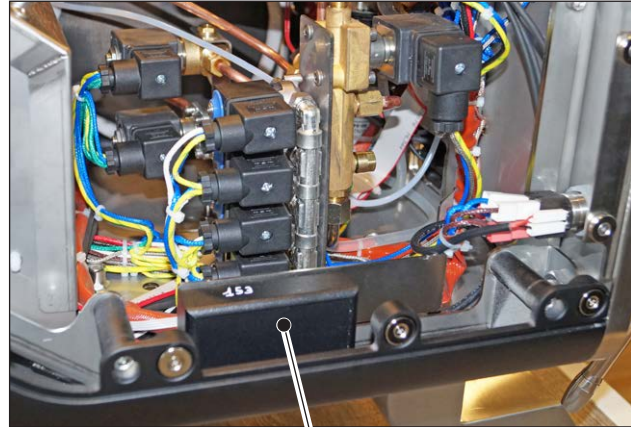

### 9.10 Removing the head and gaskets

- Leverage with a screwdriver to remove the head (1) and relevant gasket (2).



- Insert the new gasket (2) on the head (1).
- *The bevel corners "A" of the gasket must be facing upward.*

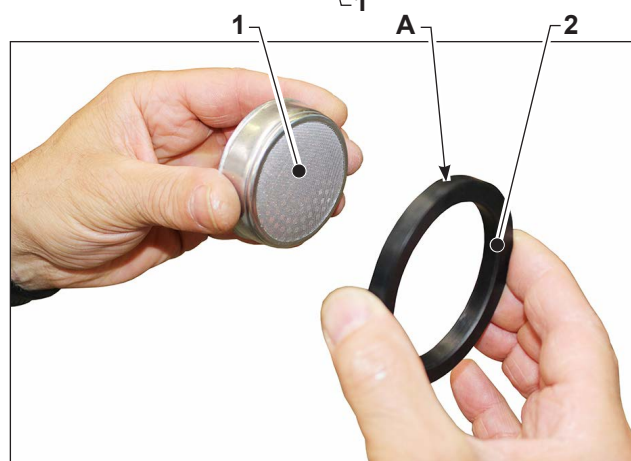

EN

- Remove the filter from the filter holder (3) and assemble the head with gasket on the filter holder (3).

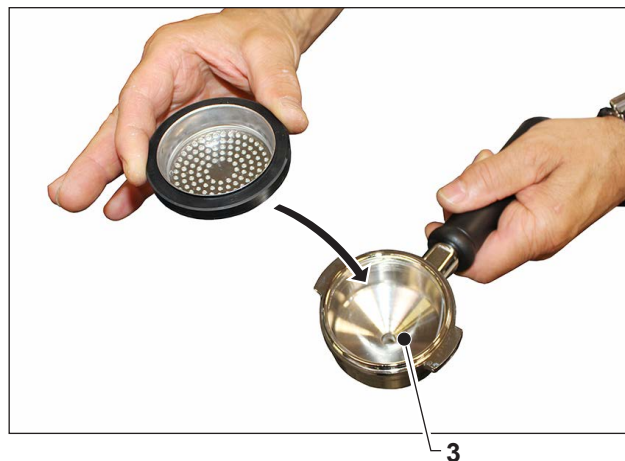

- Wet the head with water and assemble the filter holder (3) on the machine pressing thoroughly.
- Lock the filter holder (3).



### 9.11 Replacing the coffee unit solenoid valve

Each dispensing unit is equipped with a solenoid valve. To replace it, operate as follows (the operations are the same for all the solenoid valves):

- Undo the two screws (1) (one per side).

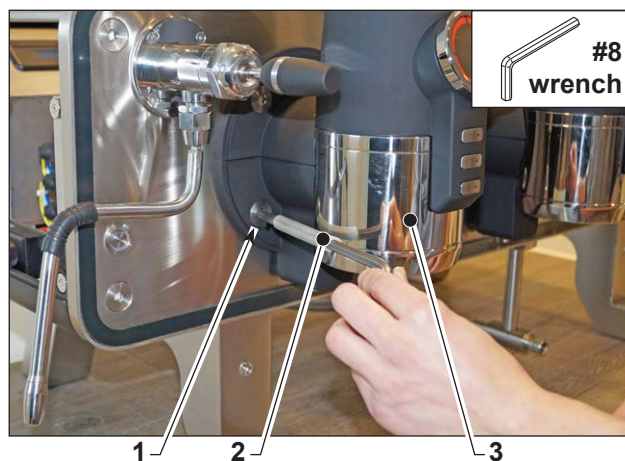

 **Protect the Allen wrench (2) to prevent damaging the steel part (3).**

- Remove the lower half-shell (4) keeping it "open" to prevent damaging the steel part (3).



EN

- Loosen the nut (5).
- Undo the four screws (6).
- Remove the solenoid valve (7).
- Refit everything operating in reverse order from removal.

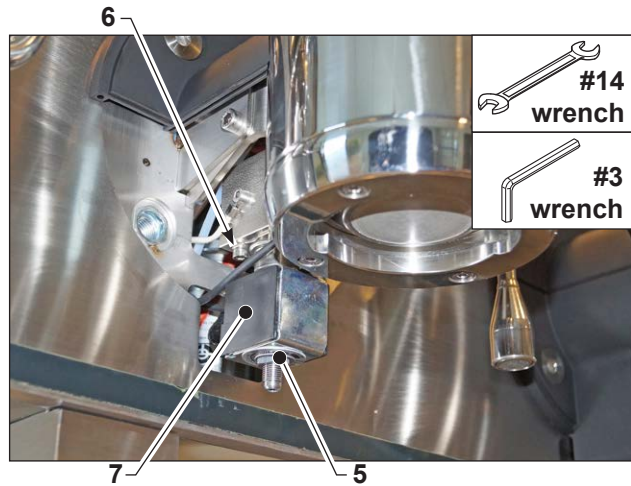

### 9.12 Removing the coffee unit display

- Unscrew the ring nut (1).
- Remove the light guide disc (2).
- Undo the two screws (3) and lift the display (4).

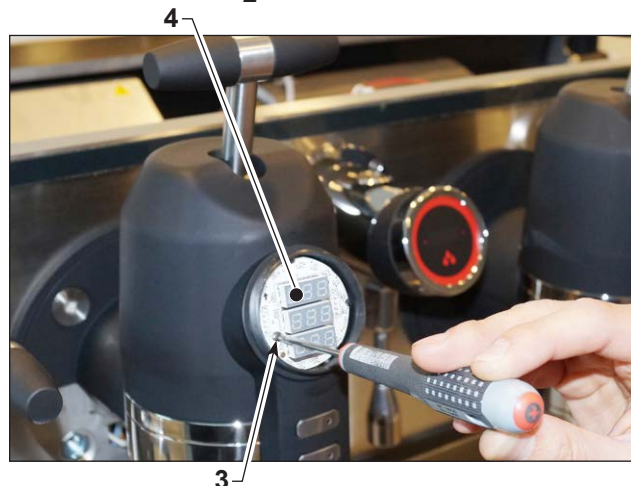
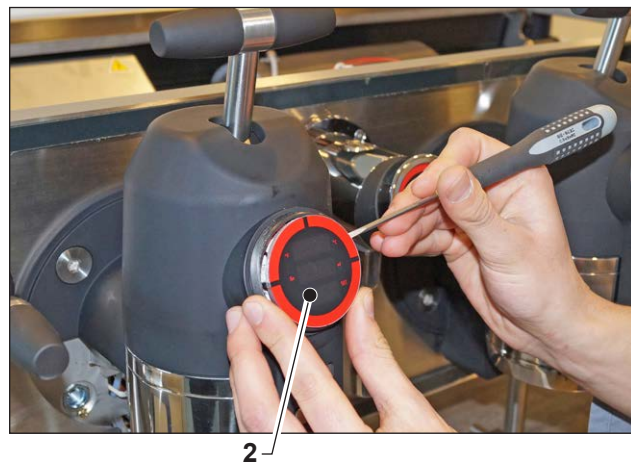
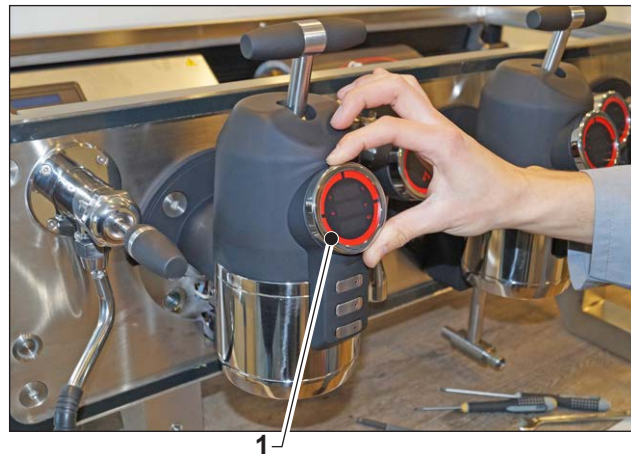

- Remove the display (4).

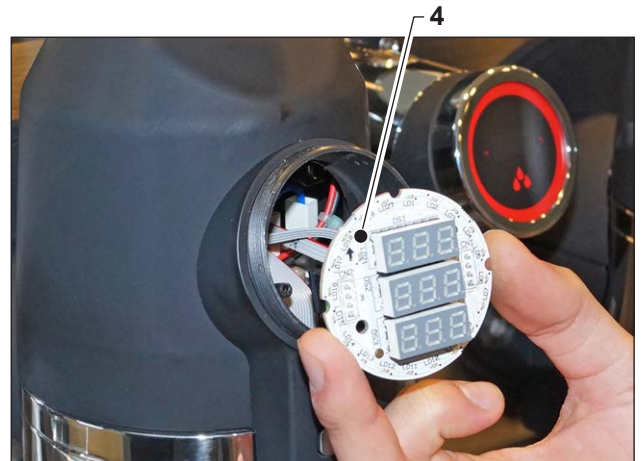

- Disconnect the two connectors:
  - Cavetto R X white connector (5).
  - Cable A X black connector (6).
- Refit everything operating in reverse order from removal.

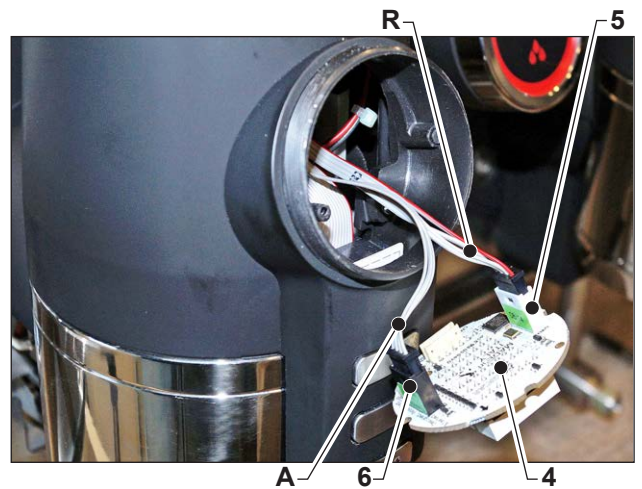

### 9.13 Removing the coffee unit pushbutton panel

- Remove the display (1) as described above.

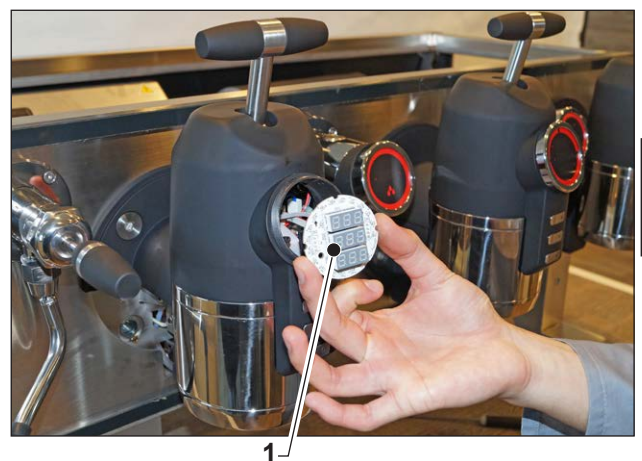

- Unscrew the two screws (2).

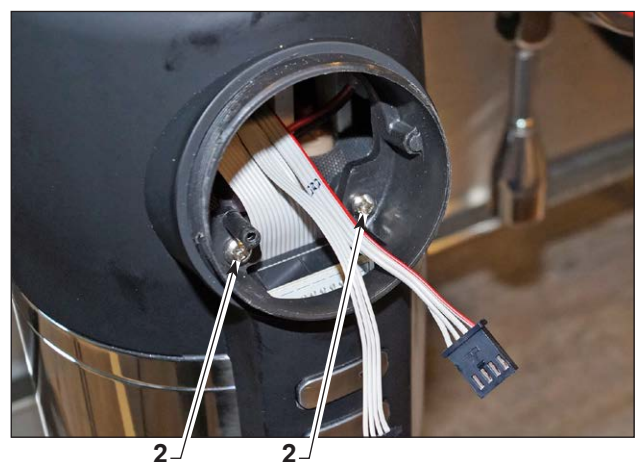

EN

- Remove the complete support (3).



3

- Disconnect the connectors (4, 5 and 6).



4

5

6

- Lift the insulating pad (7).



7

EN

- Undo the three screws (8) and remove the push-button panel (9).
- Refit everything operating in reverse order from removal.



8

8

### 9.14 Replacing the coffee unit heating element, sensor and thermostat

- Remove the heating cup and the RH side panel as described in the relative paragraphs.
- Open the tap (1) to drain the water from the boiler (2).

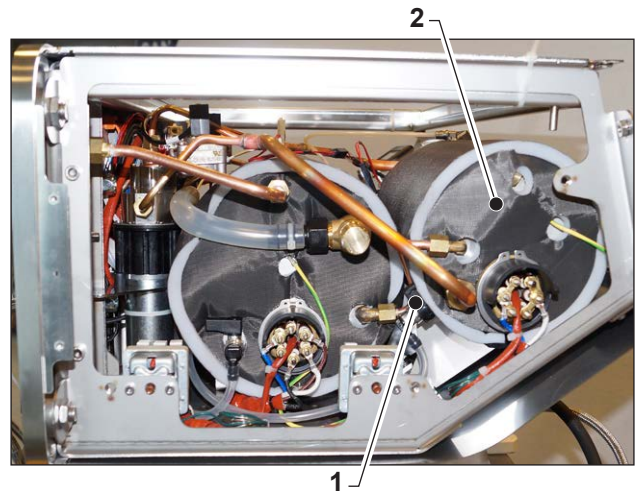

- Remove the display and the pushbutton panel as described above.
- Undo the front screw (3).

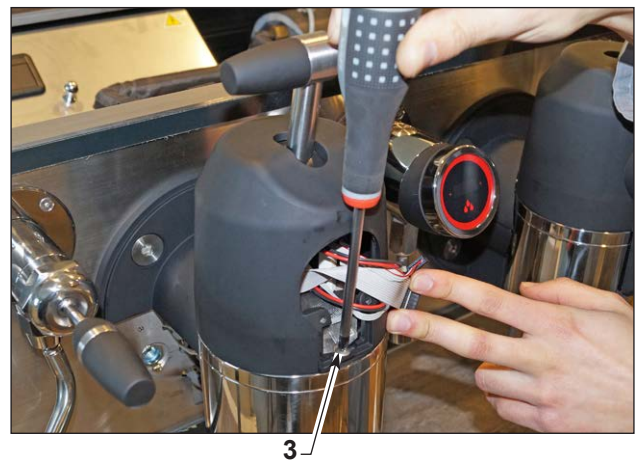

- Loosen the two grub screws (4) (one per side).

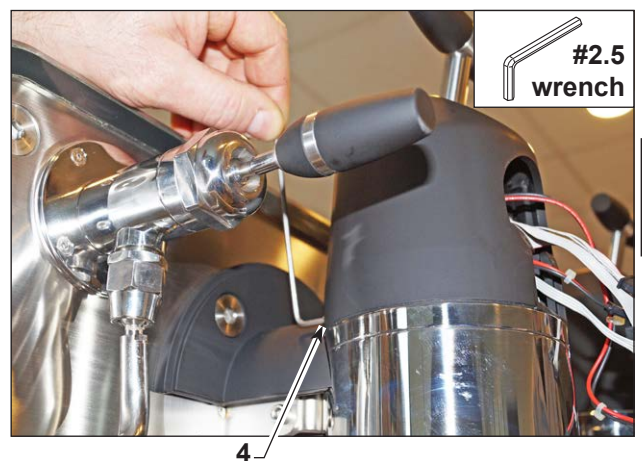

- Lift the joystick unit (5).

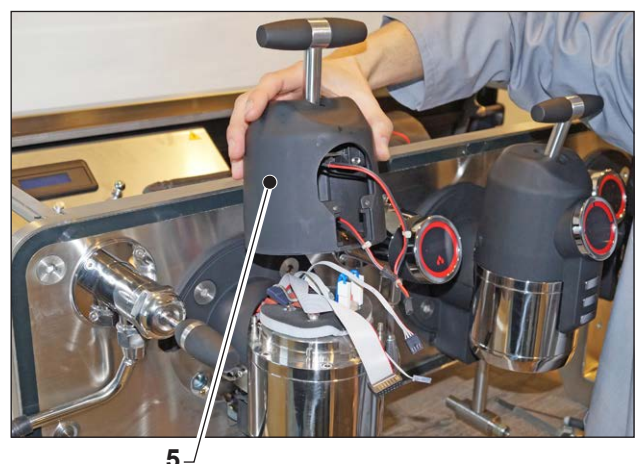

EN

- Undo the two screws (6) and remove the upper half-shell (7).

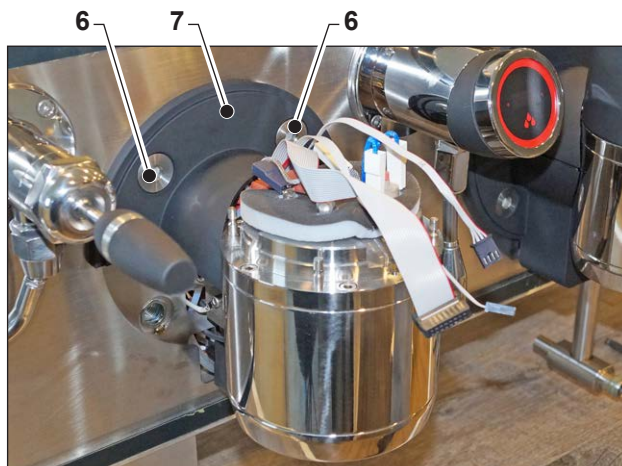

- Disconnect the connectors (8).

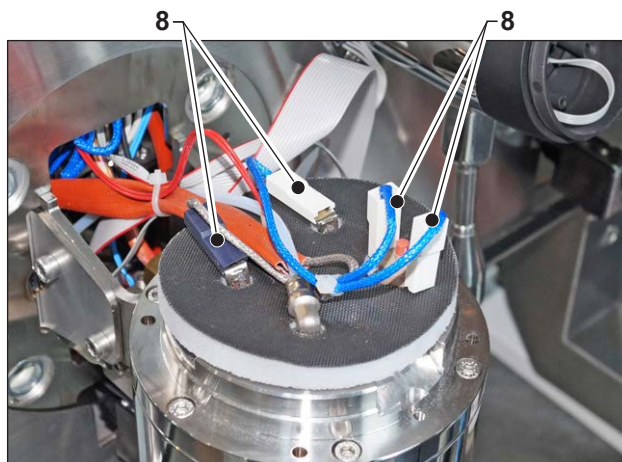

- Disconnect the Teflon tube (9).

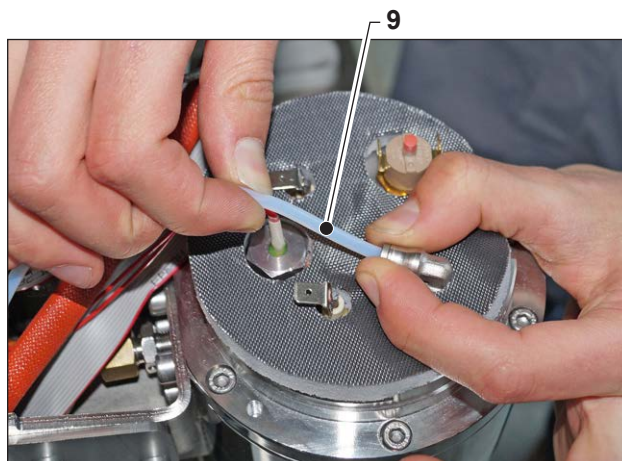

- Disconnect the connector (10) from the sensor cable.

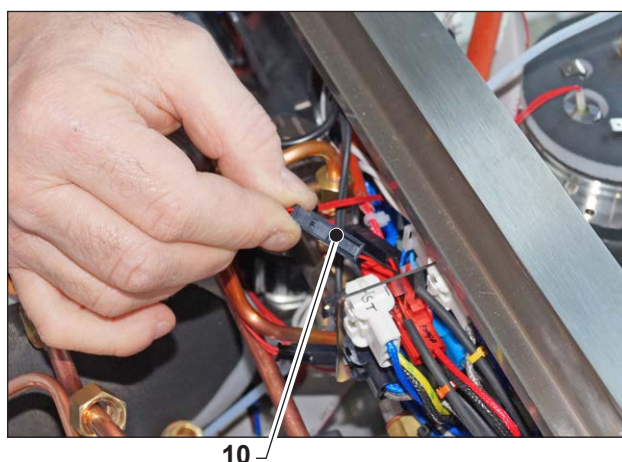

EN

- Remove the insulating disc (11).

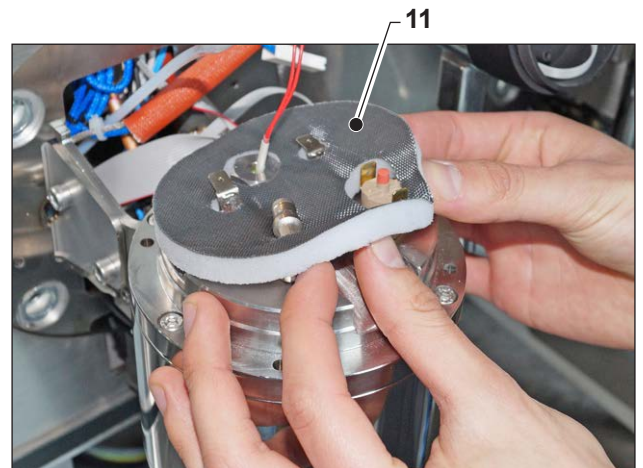

- Undo the six screws (12).

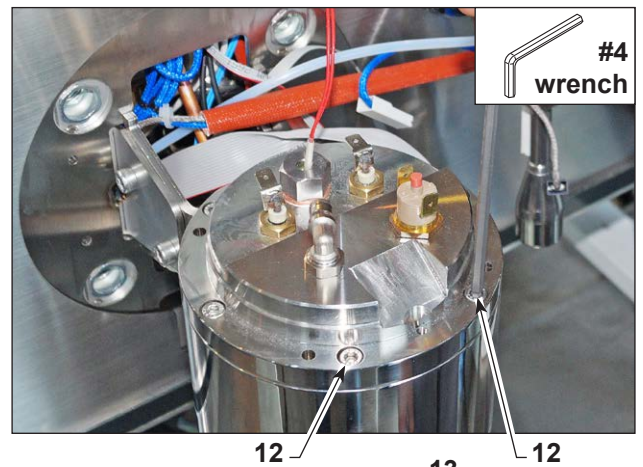

- Remove the complete flange (13).



- If necessary, replace:
  - The thermostat (14) (thermostat reset button 14a).
  - The temperature sensor (15).

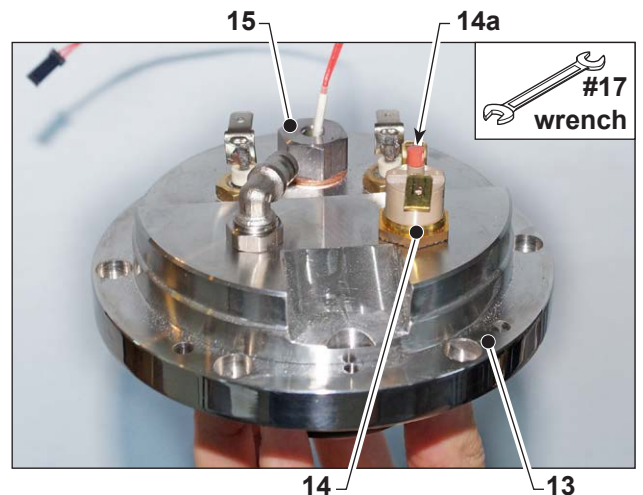

EN

- The heating element (16).

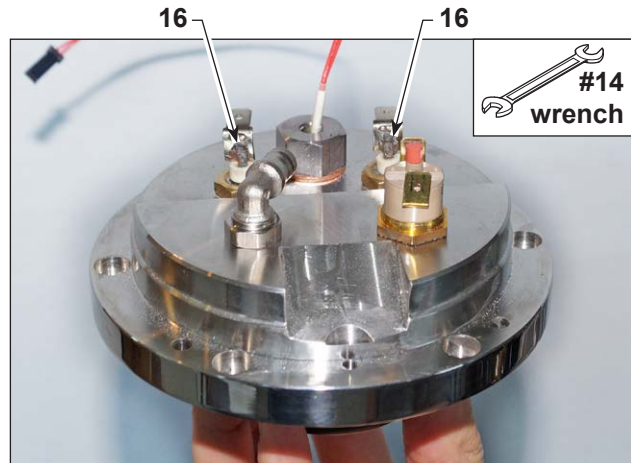

**When refitting the heating element (16), check the condition of the two O-rings (17).**



**When refitting the complete flange (13), check the condition of the O-ring (18).**

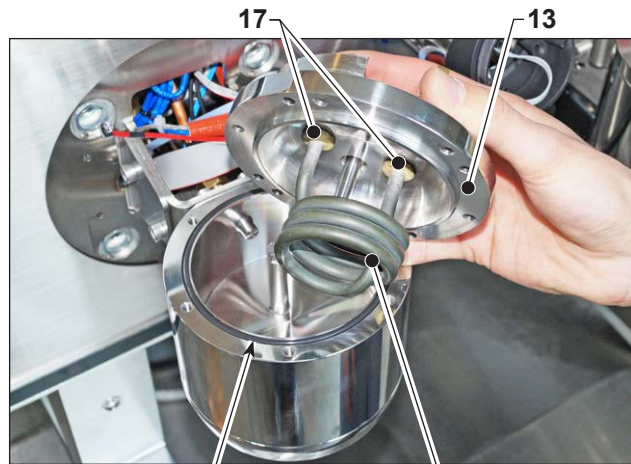

- Reassemble everything in reverse order, referring to the attached wiring diagram for electrical connections.
  - B = blue
  - G = grey / brown

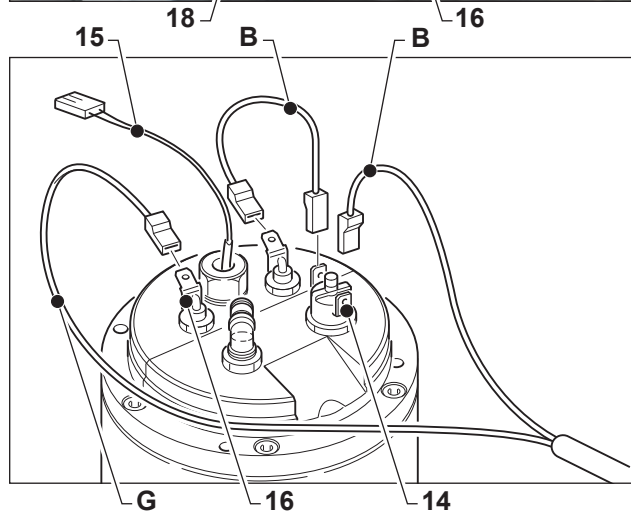

EN

### 9.15 Removing the joystick

- Remove the display and the pushbutton panel as described in the relative paragraphs.

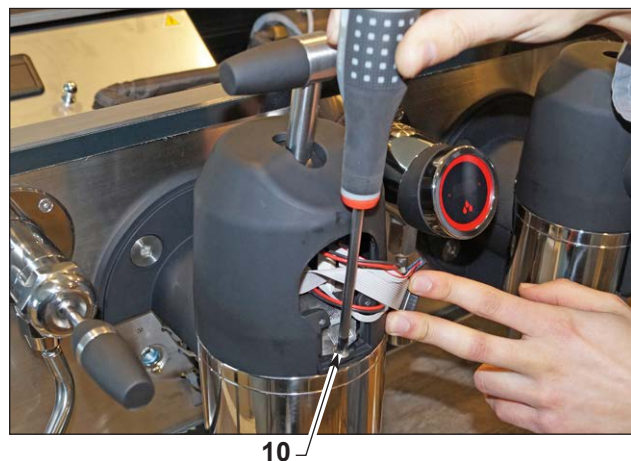

- Undo the front screw (1).

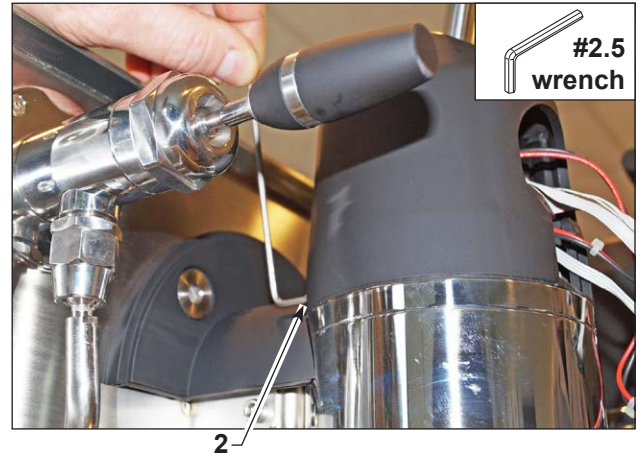

- Loosen the two grub screws (2) (one per side).

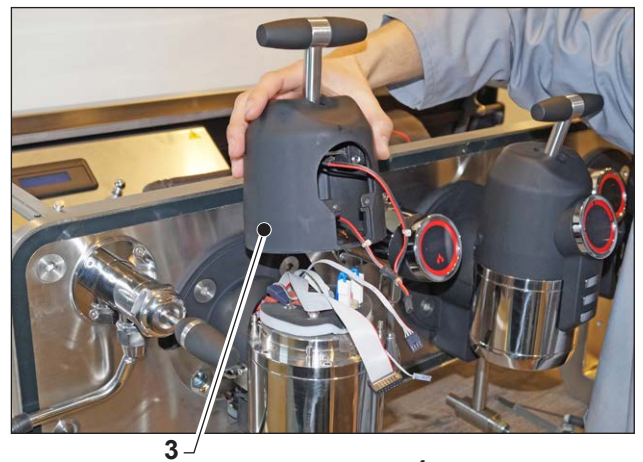

- Lift the joystick unit (3).

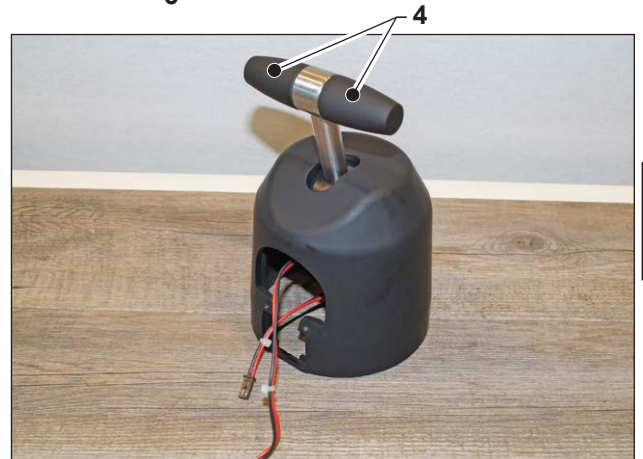

- Unscrew the two grips (4).

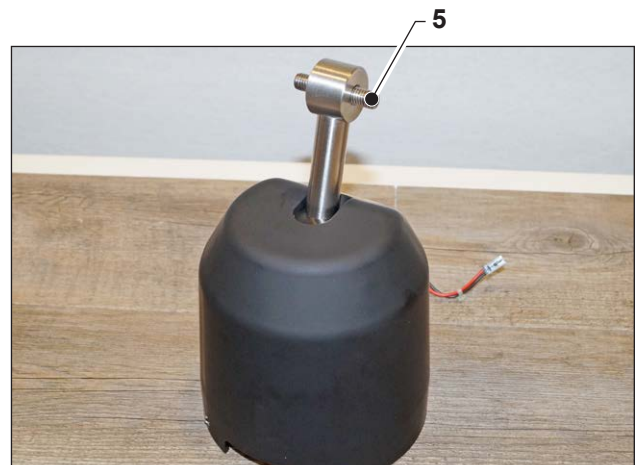

EN

- Unscrew the threaded pin (5).

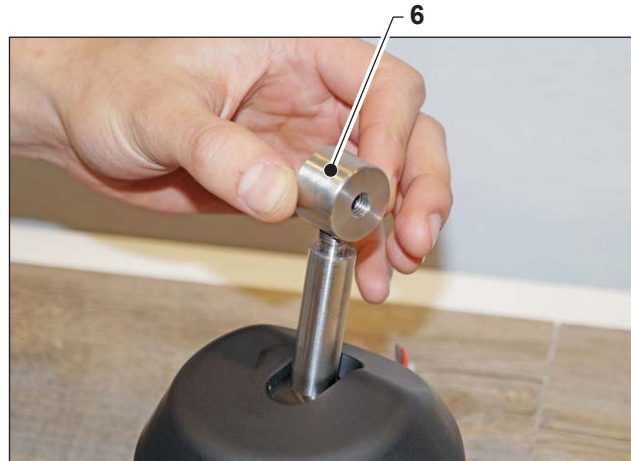

- Unscrew the pawl (6).

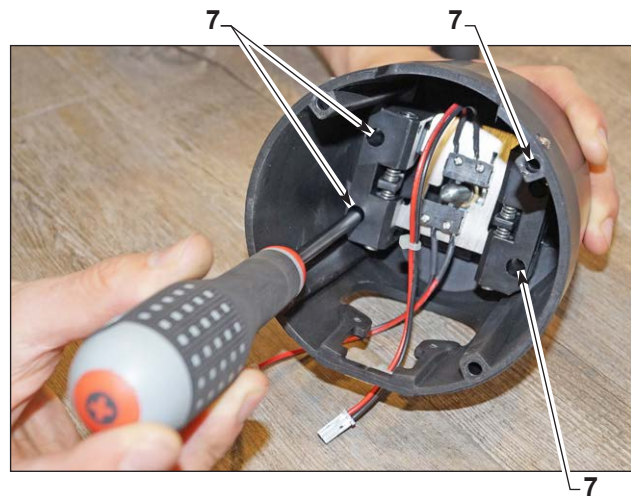

- Undo the four screws (7).

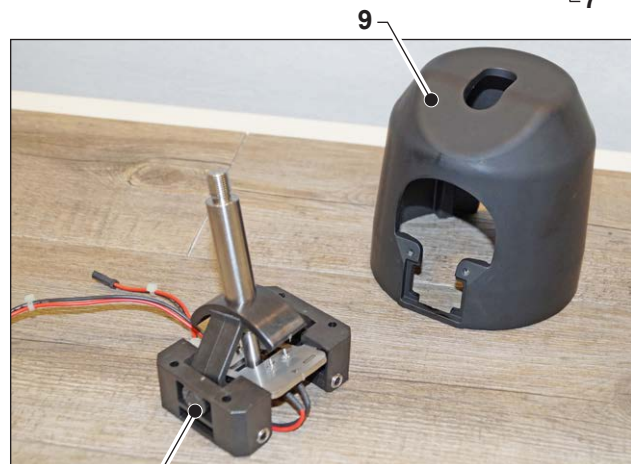

- Separate the joystick (8) from the cover (9).
- Remove the two microswitches (10) by undoing the relative screws (11).
- Refit everything operating in reverse order from removal.

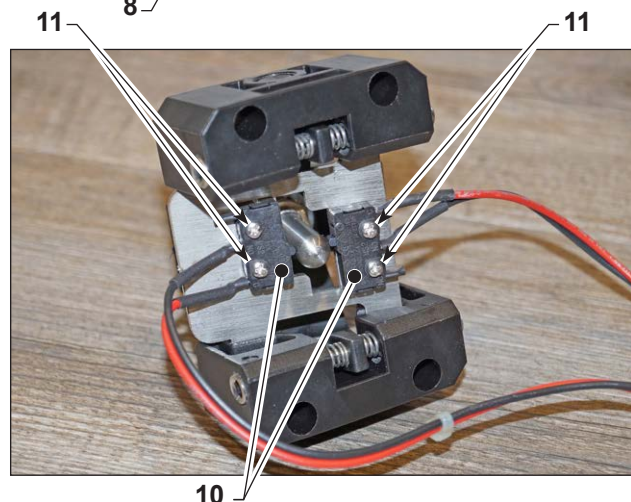

EN

### 9.16 Removing the water unit display

- Unscrew the ring nut (1).



- Remove the light guide disc (2).

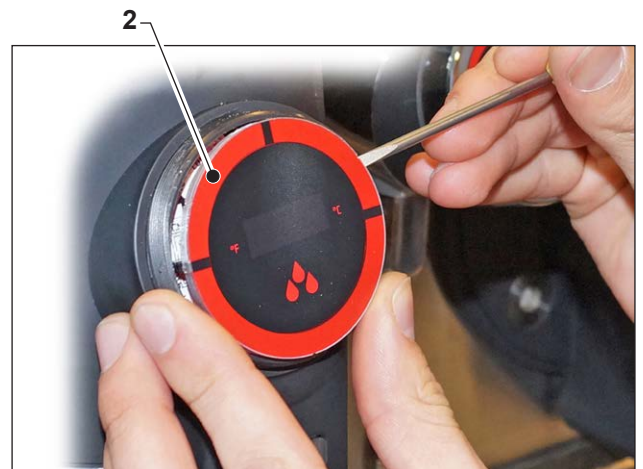

- Undo the two screws (3) and lift the display (4).

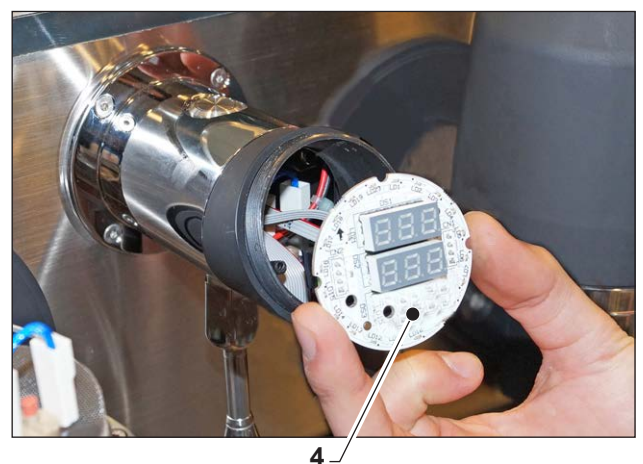

EN

- Disconnect the connectors
- **2-unit machine:**  
Cable R X > black connector (5).

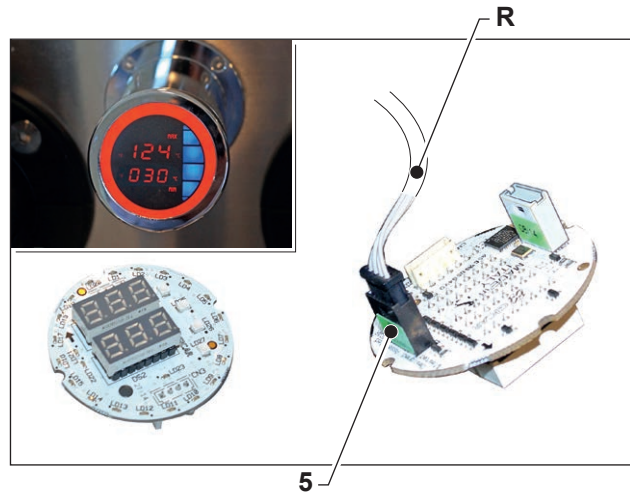

- **3-unit machine:**  
Cable R > black connector (6).  
Cable A > from white connector (7) to black connector (8).
- Refit everything operating in reverse order from removal.

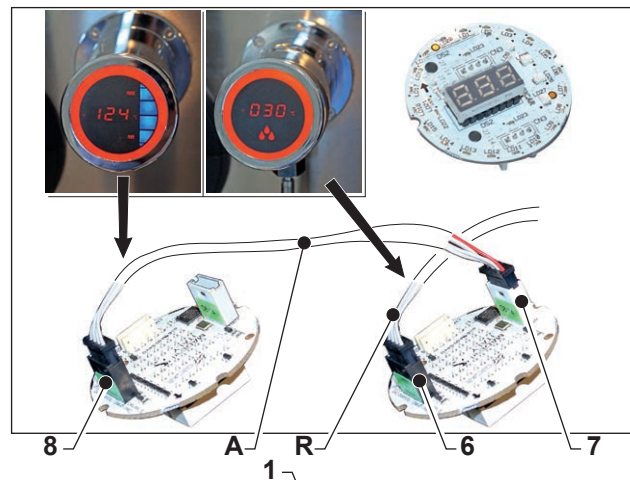

### 9.17 Removing the hot water tube and water tap button

- Turn off the machine with the switch (1).



- Refit the display as described in the relative paragraph.

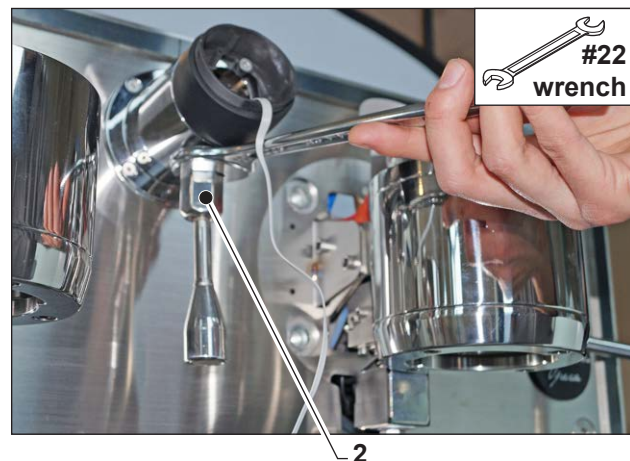

- Unscrew the water dispensing tube (2).

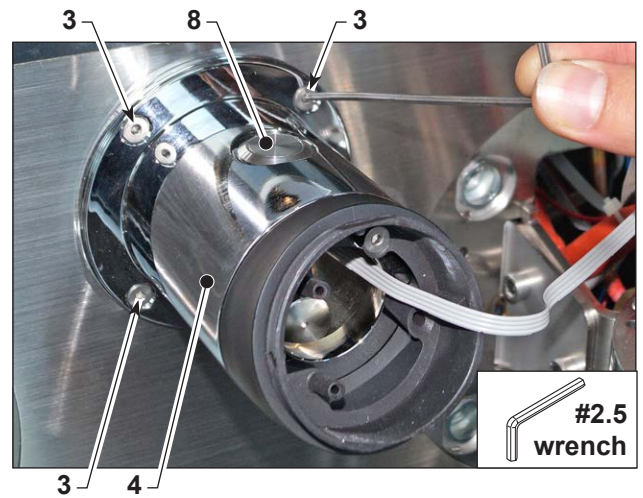

- Undo the four screws (3) to remove the unit (4).



- Turn the unit (4) 180°.
- Loosen the two terminals (5) to disconnect the electric cables (6).

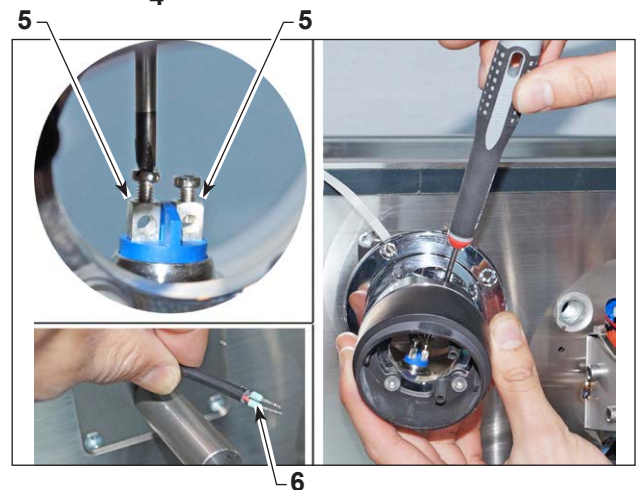

- Unscrew the nut (7) to remove the button (8).
- Refit everything operating in reverse order from removal.

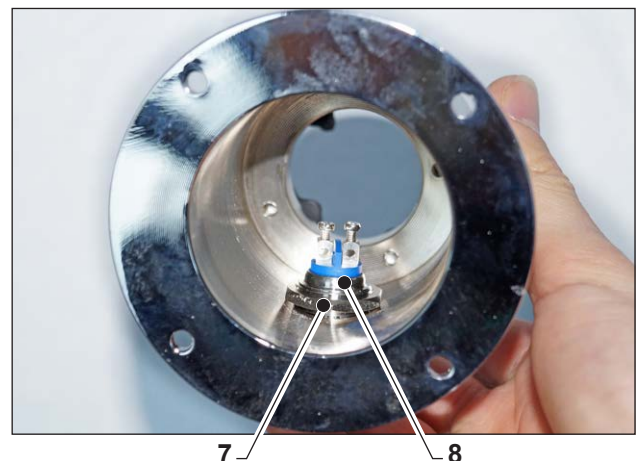

EN

### 9.18 Removing the steam tap



**Make sure that the machine is not pressurized.**

- Remove the heating cup and the LH side panel as described in the relative paragraphs.
- Unscrew the union (1).
- Loosen the union (2) on the boiler.

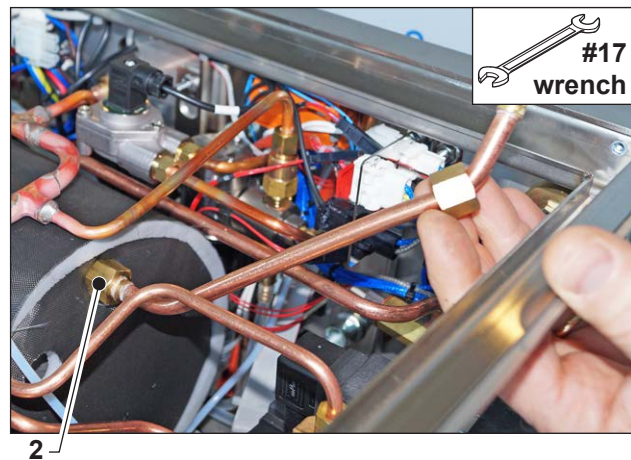
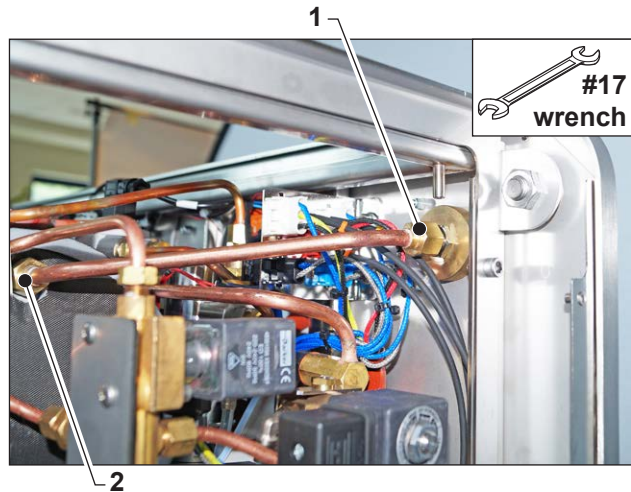

- Holding the tap, unscrew the nut (3).

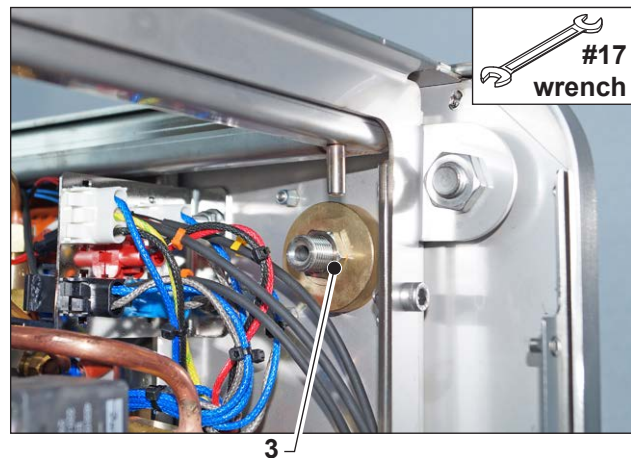

- Remove the complete tap (4), the nut (3) and the brass disc (5).
- Refit everything operating in reverse order from removal.

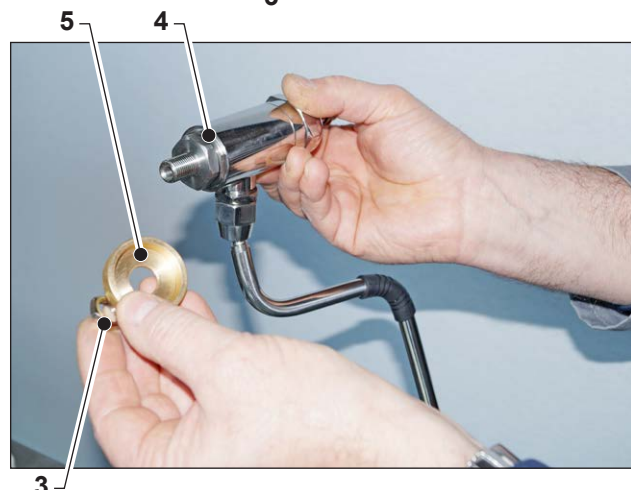

### 9.19 Replacing the safety thermostat

- Turn off the machine with the switch (1).
- Remove the heating cup and the RH side panel as described in the relative paragraphs.
- Unscrew the two screws (2) and remove the thermostat
  - Coffee boiler thermostat (3).
  - Service boiler thermostat (4).
- Disconnect the connectors (5).
- Remove the sensor from the boiler.
- Reassemble everything in reverse order, referring to the attached wiring diagram for electrical connections.

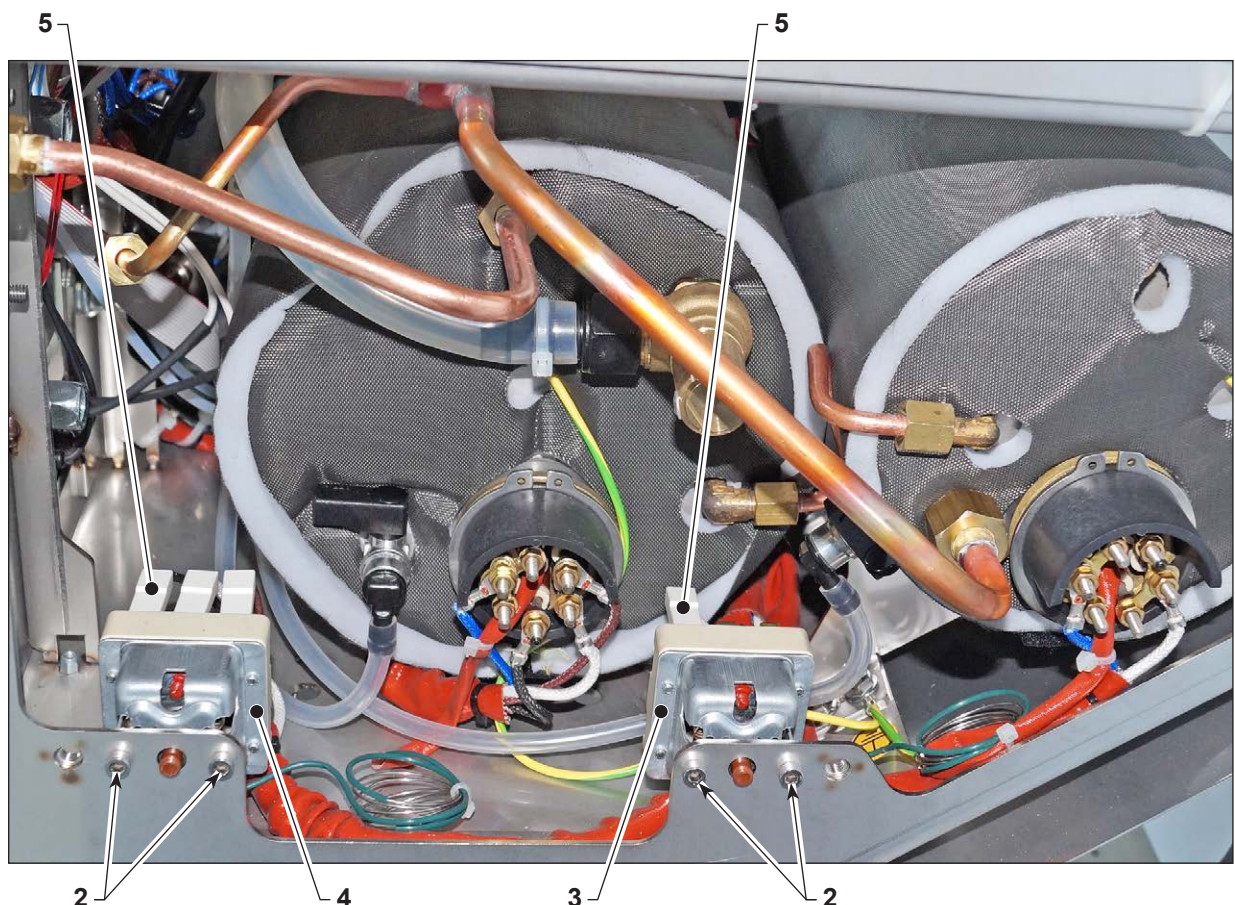
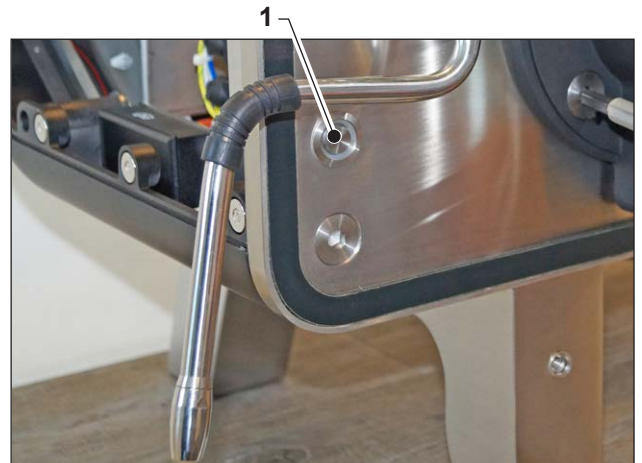

### 9.20 Removing the service boiler

- Turn off the machine with the switch (1).
- Remove the heating cup and the panels as described in the relative paragraphs.
- Drain the water from the boiler (9) by opening the tap (2). Close the tap (2).
- Detach all the copper tubes from the boiler (1) by unscrewing all the unions.

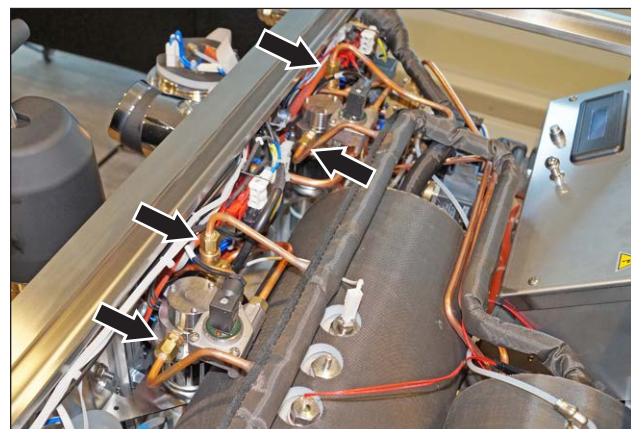
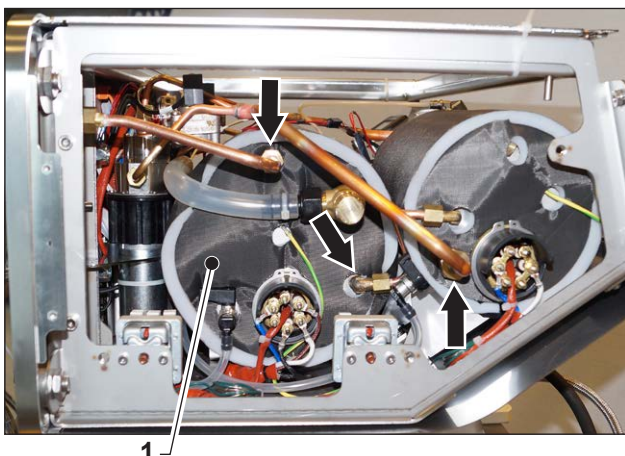
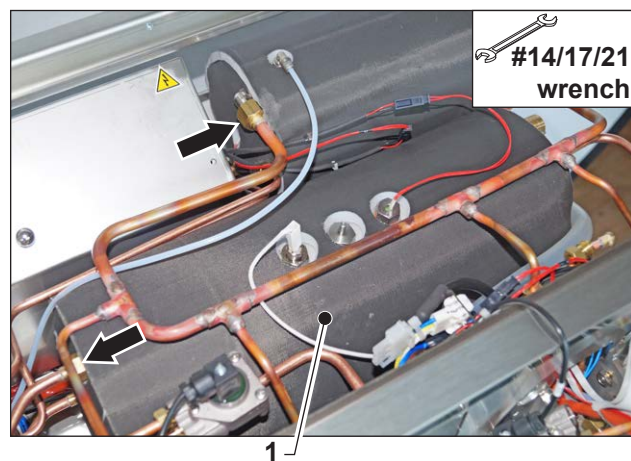
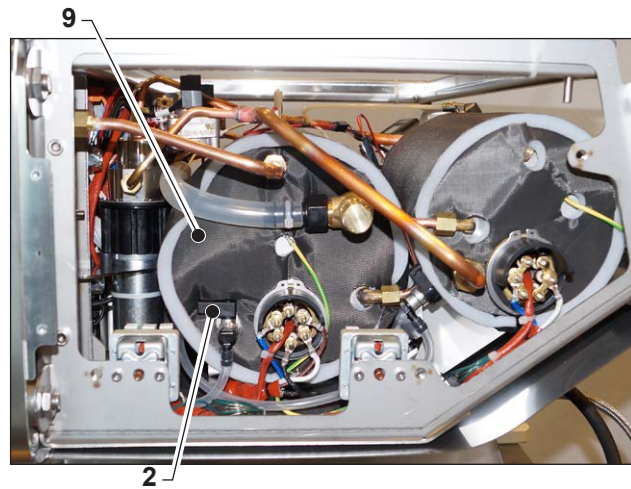

EN

- Disconnect the drain tube (3) of the safety valve and the tube (4) of the tap (2).

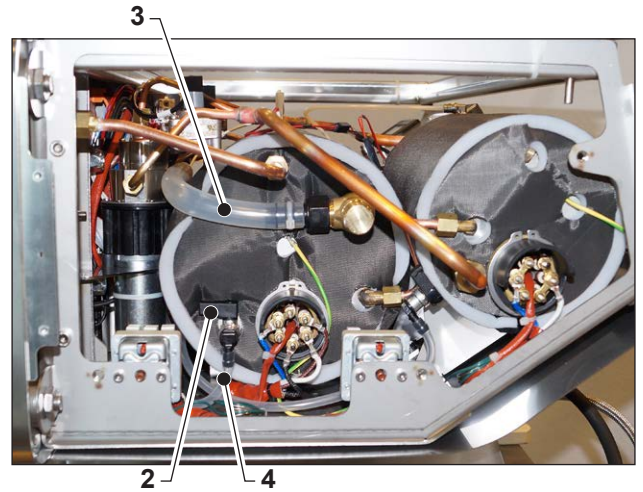

- Disconnect all the electrical connections of the heating element (5).

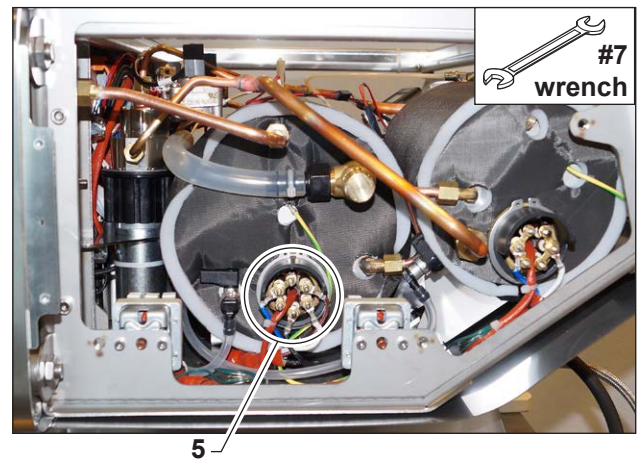

- Disconnect the green/yellow earth cable (6).

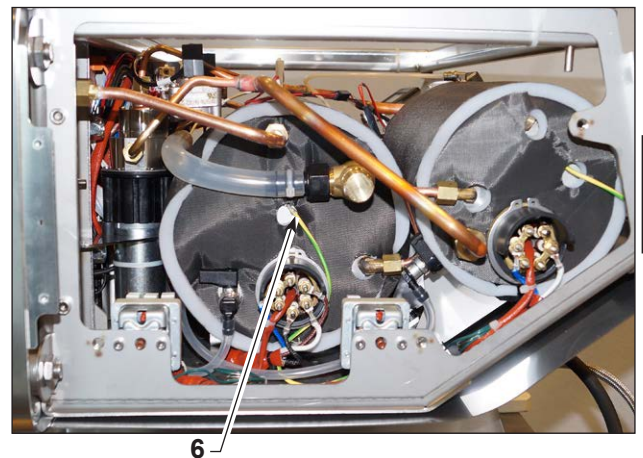

- Disconnect the connector (7) of the temperature sensor and the connector (8) of the level sensor
- Lift the boiler (9) to remove it from the machine.
- Reassemble everything in reverse order, referring to the attached wiring diagram for electrical connections.

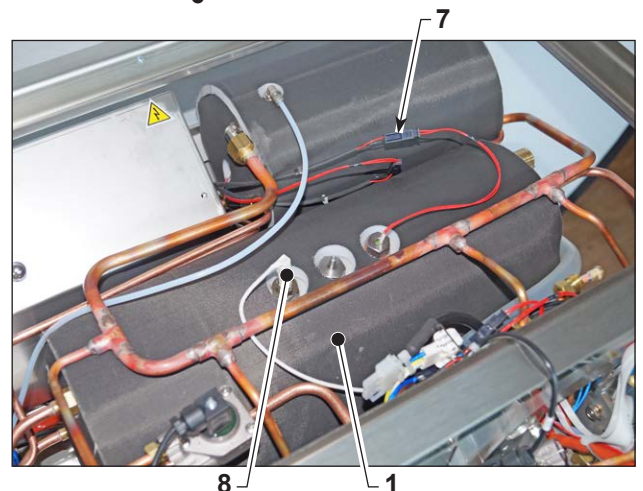

EN

### 9.21 Removing the coffee boiler

- Turn off the machine with the switch (1).
- Remove the heating cup and the side panels as described in the relative paragraphs.
- Drain the water from the boiler (7) by opening the tap (2).  
Close the tap (2).
- Detach all the copper tubes from the boiler (1) by unscrewing all the unions.

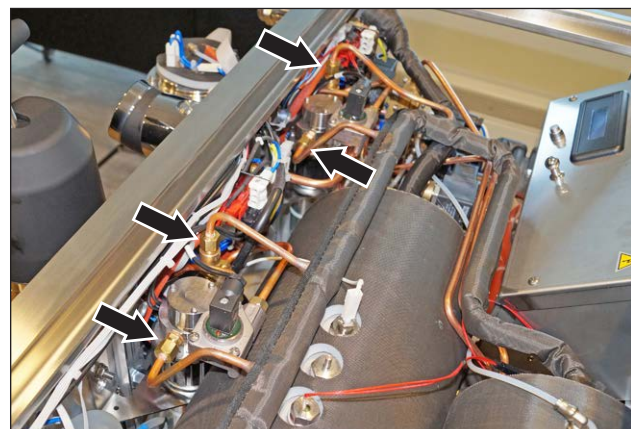
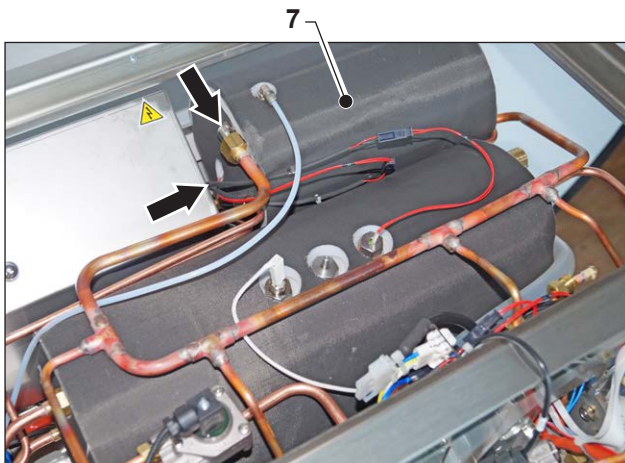
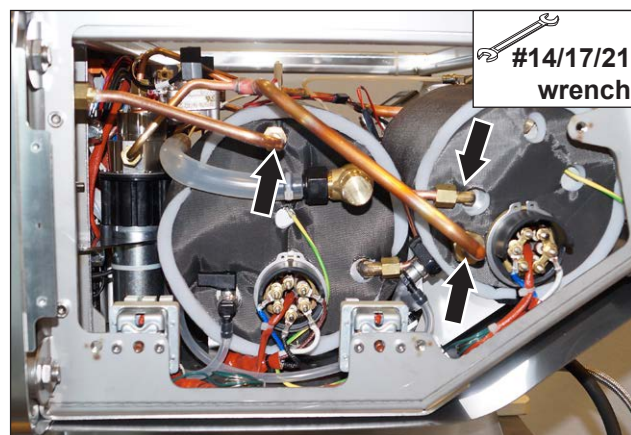
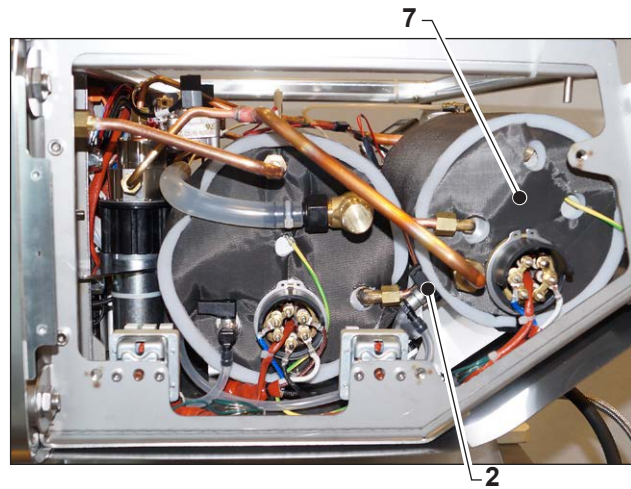

EN

- Disconnect the transparent tube (3) and the tube (4) of the tap (2).

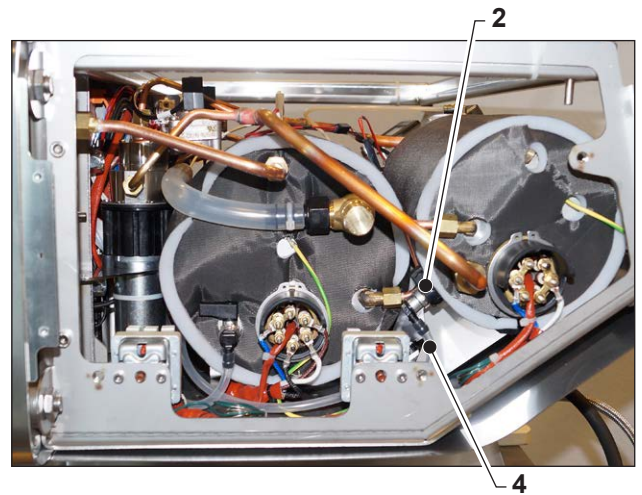
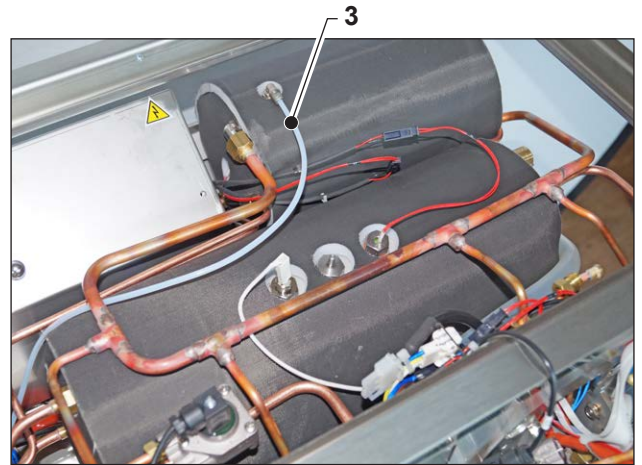

- Disconnect all the electrical connections of the heating element (6).

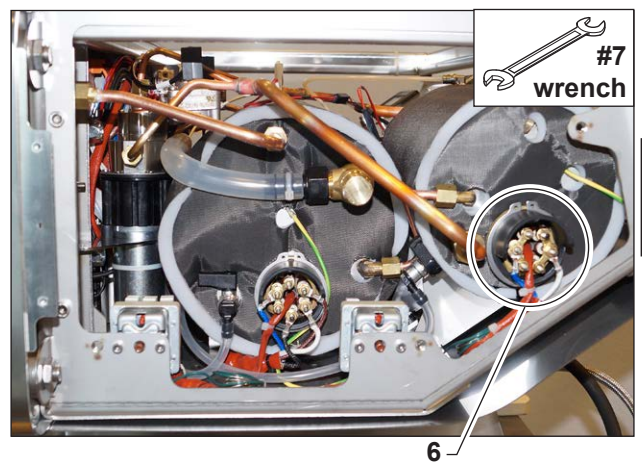

- Disconnect the connector (8) of the temperature sensor.

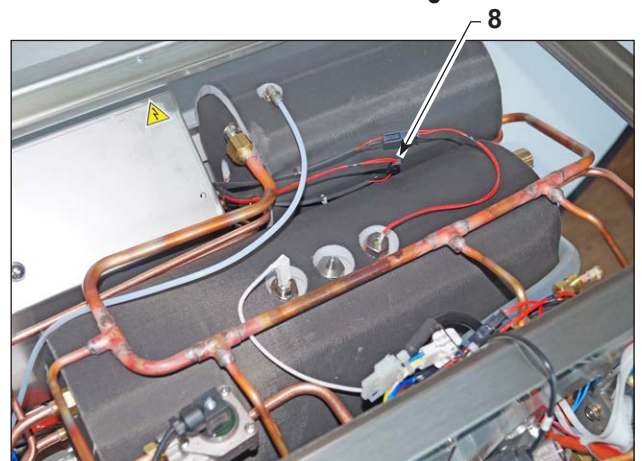

EN

- Disconnect the green/yellow earth cable (5).
- Disconnect the boiler (7) to remove it from the machine.
- Reassemble everything in reverse order, referring to the attached wiring diagram for electrical connections.

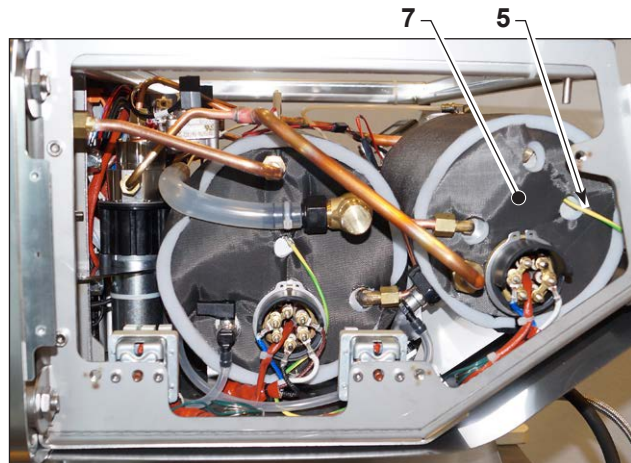

### 9.22 Replacing the main switch



**Make sure that the main switch upstream of the machine is in OFF position, then post a sign on the main switch saying "Maintenance in progress" so that no one turns on the power during this operation.**

- Remove the heating cup and the LH side panel as described in the relative paragraphs.
- Disconnect all the connectors (1).
- Unscrew the ring nut (2).
- Remove the switch (3).
- Reassemble everything in reverse order, referring to the attached wiring diagram for electrical connections.

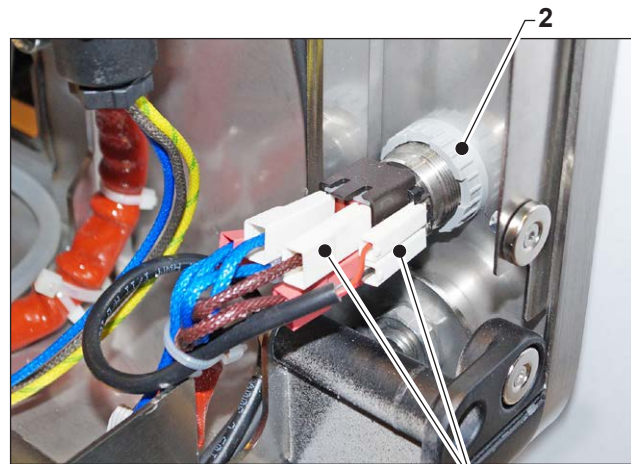

EN

### 9.23 Replacing the LED strip

- Remove the heating cup, the side panels and the rear panel as described in the relative paragraphs.
- Turn off the machine with the switch (1).

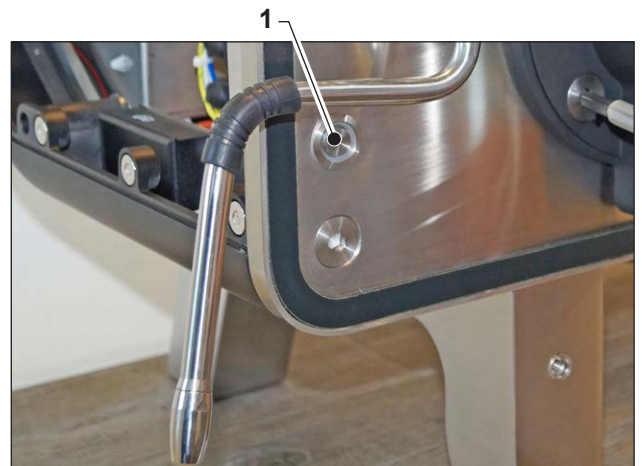

- Undo the two screws (2) and open the cover (3).

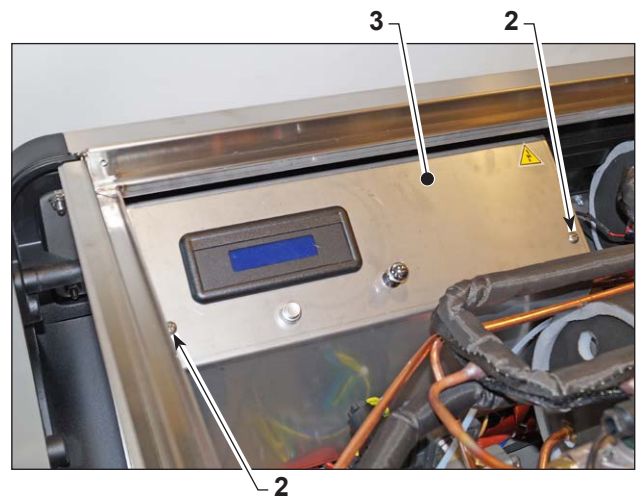

- Disconnect the two cables (10).



- Undo the screw (4) (one per side).

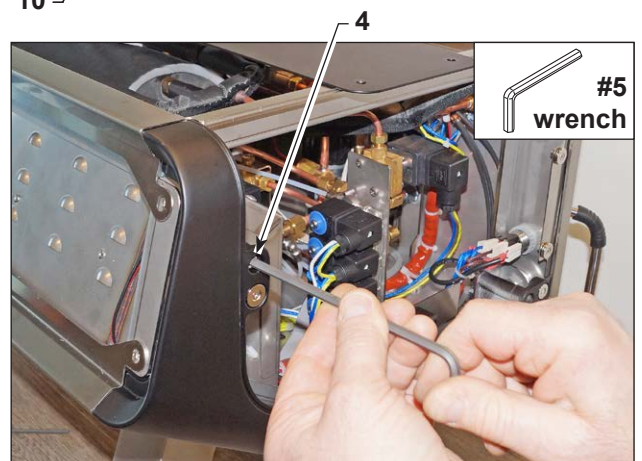

EN

- With two persons operating, hold open the two side panels (5) and remove the cross-piece (6) complete with LED strip.

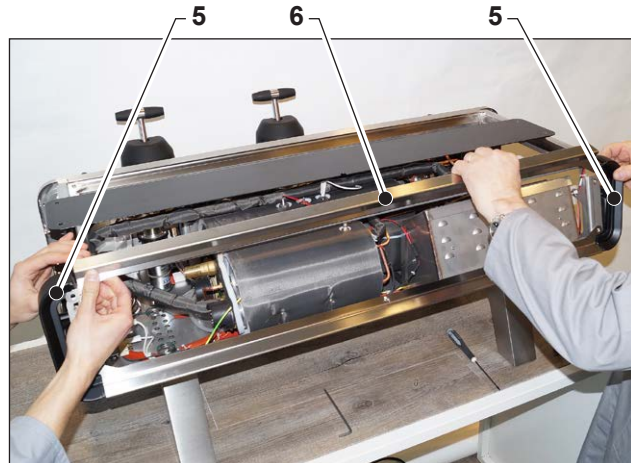

**a: First machine version**

- The LED strip (7) is glued into the cross-piece (6). Detach it to replace it.

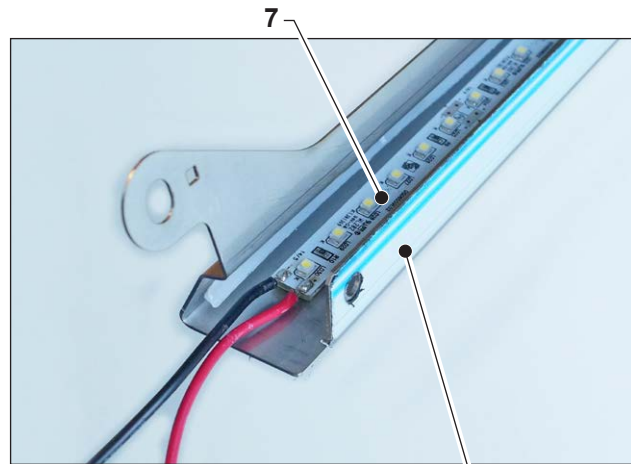

**b: New machine version**

- Unscrew the three nuts (8) to remove the LED strip complete with support (9) from the cross-piece (6).
- Refit everything operating in reverse order from removal.

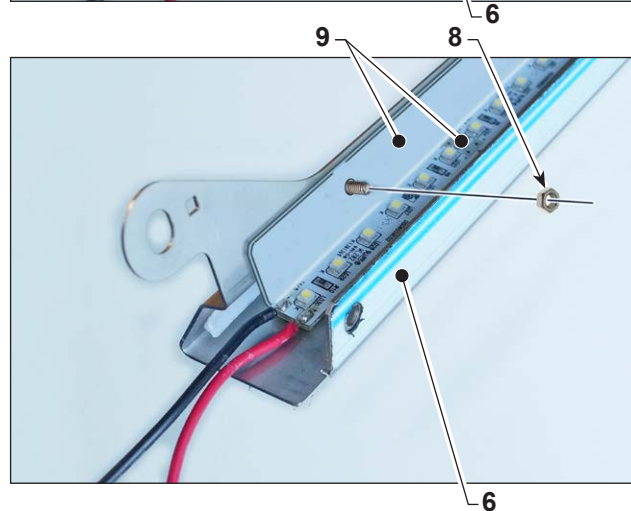

## 10. PROGRAMMING BY THE TECHNICIAN

- The machine can be programmed in two ways:
  - From the display (1) (see paragraph 10.1).
  - From the tablet (2) provided with the dedicated software pre-installed and connected to the machine via Bluetooth (see paragraph 10.2).

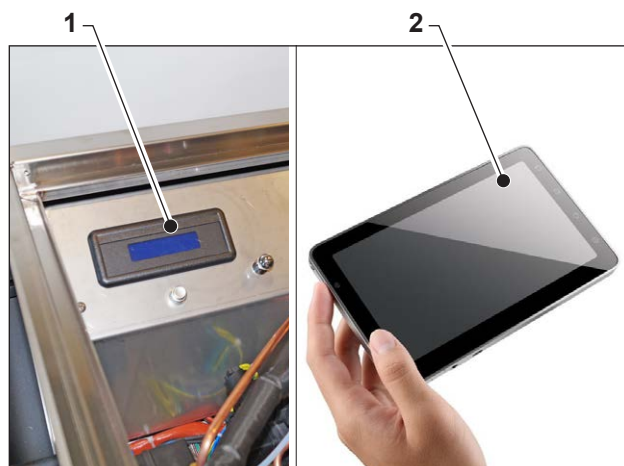

### 10.1 Programming from display

- The display (1) is positioned inside the machine. To access it, remove the heating cup as described in the relative paragraph.
- Programming is done using the three buttons (A - B - C) on the first unit on the left (2).

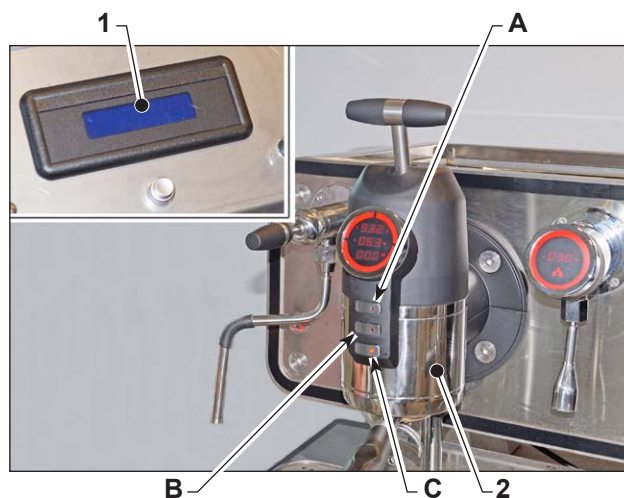

- When the machine is turned on, the model name is shown on the display.



- To access programming, hold down the button "C" and then press the button "B". All the unit displays turn off and OFF is shown on the display (1); release the buttons.

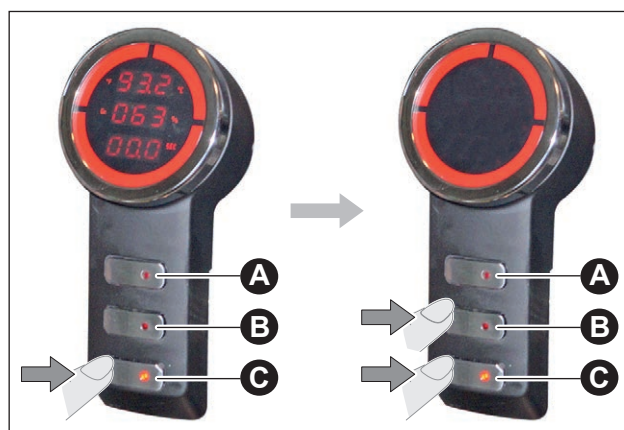

EN

 In this condition, the machine is off.



- The button "C" blinks. Hold it down until **PASS-WORD** is shown on the display (about 10 seconds).



EN



- Press the button "C" 5 times until the language is shown on the display.
- From this point on, you can select or set the desired value using the buttons "A" and "B" and confirm the selection and/or go to the next section using the button "C".



The sequence of settable fields is type cascade according to the order shown in Table "A".



- If no button (A - B - C) is pressed for one minute, the software exits normal operating mode.
- If a new value is set (e.g. a new language) and the button "C" is not pressed, the new setting will not be stored.

SEE THE PREVIOUS PAGE 



EN

|    | ITALIANO                   |                  | ENGLISH                   |                  |
|----|----------------------------|------------------|---------------------------|------------------|
| 1  | PASSWORD                   | 5 X 3° TASTO     | PASSWORD                  | 5 X 3RD BUTTON   |
| 2  | LINGUA                     | ITALIANO         | LANGUAGE                  | ENGLISH          |
| 3  | NOME                       | OPERA            | NAME                      | OPERA            |
| 4  | TELEFONO ASSIST.           |                  | SERVICE PHONE             |                  |
| 5  | NUMERO GRUPPI              | 3                | GROUPS NUMBER             | 3                |
| 6  | FUNZIONE CRONO             | ABILITATO        | CRONO FUNCTION            | ENABLED          |
| 7  | CELLE DI CARICO            | DISABILITATO     | CELLE DI CARICO           | DISABLED         |
| 8  | WATT                       | 6500W            | WATT                      | 6500W            |
| 9  | TRASD.PRESS.VAP            | DISABILITATO     | PROBE STEAM PRESS         | DISABLED         |
| 10 | VIS. PRESS.VAP             | DISABILITATO     | DISP STEAM PRESS          | DISABLED         |
| 11 | VIS.PRESS.GR               | ABILITATO        | DISP PRESS GR             | ENABLED          |
| 12 | PROGR. DOSI                | ABILITATO        | DOSES SETTING             | ENABLED          |
| 13 | TE + POMPA                 | SI               | TEA + PUMP                | YES              |
| 14 | PREINFUSIONE               | ABILITATO        | PRE-BREWING               | ENABLED          |
|    | PREINFUSIONE GR1 1DOSE     | 3 SEC            | PRE-BREWING GR1 1DOSE     | 3 SEC            |
|    | PREINFUSIONE GR1 2DOSI     | 5 SEC            | PRE-BREWING GR1 2 DOSES   | 5 SEC            |
|    | PREINFUSIONE GR2 1DOSE     | 3 SEC            | PRE-BREWING GR2 1 DOSE    | 3 SEC            |
|    | PREINFUSIONE GR2 2DOSI     | 5 SEC            | PRE-BREWING GR2 2 DOSES   | 5 SEC            |
|    | PREINFUSIONE GR3 1DOSE     | 2 SEC            | PRE-BREWING GR3 1 DOSE    | 2 SEC            |
|    | PREINFUSIONE GR3 2DOSI     | 4 SEC            | PRE-BREWING GR3 2 DOSES   | 4 SEC            |
| 15 | POSTINFUSIONE GR1 1DOSE    | 3 ml             | POST-BREWING GR1 1 DOSE   | 3 ml             |
|    | POSTINFUSIONE GR1 2DOSI    | 5 ml             | POST-BREWING GR1 2 DOSES  | 5 ml             |
|    | POSTINFUSIONE GR2 1DOSE    | 3 ml             | POST-BREWING GR2 1 DOSE   | 3 ml             |
|    | POSTINFUSIONE GR2 2DOSI    | 5 ml             | POST-BREWING GR2 2 DOSES  | 5 ml             |
|    | POSTINFUSIONE GR3 1DOSE    | 3 ml             | POST-BREWING GR3 1 DOSE   | 3 ml             |
|    | POSTINFUSIONE GR3 2DOSI    | 5 ml             | POST-BREWING GR3 2 DOSES  | 5 ml             |
| 16 | CONTR.FLUSSO               | DISABILITATO     | FLOW CONTROL              | DISABLED         |
| 17 | SENSIBILITA'               | MEDIA            | PROBE SENSIVITY           | MID              |
| 18 | CICLI DI MANUTENZIONE      | 0                | SERVICE CYCLES            | 0                |
| 19 | TEMPERATURA                | ABILITATO        | TEMPERATURE               | ENABLED          |
| 20 | TEMPERATURA                | °c - °F          | TEMPERATURE               | °C-°F            |
| 21 | TEMPERATURA CALDAIA STEAM  | 124              | TEMPERATURE STEAM BOILER  | 124              |
|    | KP KI KD                   | 8,0 - 0,15 - 4,7 | KP KI KD                  | 8,0 - 0,15 - 4,7 |
|    | PID SETTING                | 1                | PID SETTING               | 1                |
| 22 | TEMPERATURA CALDAIA CAFFE' | 75               | TEMPERATURE COFFEE BOILER | 75               |
|    | KP KI KD                   | 0,6 - 0,10 - 3,5 | KP KI KD                  | 0,6 - 0,10 - 3,5 |
|    | PID SETTING                | 6                | PID SETTING               | 6                |
| 23 | OFF SET GR1                | 0                | OFF SET GR1               | 0                |
|    | OFF SET GR2                | 0                | OFF SET GR2               | 0                |
|    | OFF SET GR3                | 0                | OFF SET GR3               | 0                |
|    | KP KI KD                   | 0,6 - 0,05 - 3,4 | KP KI KD                  | 0,6 - 0,05 - 3,4 |
|    | PID SETTING                | 6                | PID SETTING               | 6                |
| 24 | OFF SET PORTAF. 1          | 1                | OFF SET HOLDER. 1         | 1                |
|    | OFF SET PORTAF. 2          | 1                | OFF SET HOLDER. 2         | 1                |
|    | OFF SET PORTAF. 3          | 1                | OFF SET HOLDER. 3         | 1                |
|    | KP KI KD                   | 1,6 - 0,06 - 3,5 | KP KI KD                  | 1,6 - 0,06 - 3,5 |
|    | PID SETTING                | 6                | PID SETTING               | 6                |
| 25 | TEMPO DI INATTIVITA'       | 2                | TIME INACTIVITY           | 2                |
|    | OFF SET RIPOSO             | 0                | OFS TIME INACTIVITY       | 0                |
| 26 | TIME OUT RIEMPIMENTO       | 120"             | FILLING UP TIME           | 120"             |
| 27 | FILTRO ACQUA               | 0000             | WATER FILTER              | 0                |
| 28 | SCALDATAZZE                | ABILITATO        | HEATING CUP               | ENABLED          |
| 29 | SCALDATAZZE                | 50%              | HEATING CUP               | 50%              |
| 30 | CAMBIO PASSWORD            | NO               | CHANGE PASSWORD           | NO               |

EN

### 10.1.a Programmable section sequence

- The first programmable section after entering the **PASSWORD** is the language.

#### Language

In this section, you can set the language for the messages shown on the display.

- Press the button “**A**” or “**B**” to change the language.

Press the button “**C**” to confirm the selection and go to the next section.

The available languages are:

Italian, English, French, German, Spanish.



#### Name

In this section, you can set the machine name (the modifiable field blinks).

- Press the button “**A**” to view the letter or the button “**B**” to confirm the letter and go to the next one.

Press the button “**C**” to confirm the name and go to the next section.



#### Service Phone

In this section, you can set the phone number of the service centre (the modifiable field blinks).

- Press the button “**A**” to view/set the number or the button “**B**” to confirm the number and go to the next one.

Press the button “**C**” to confirm the phone number set and go to the next section.

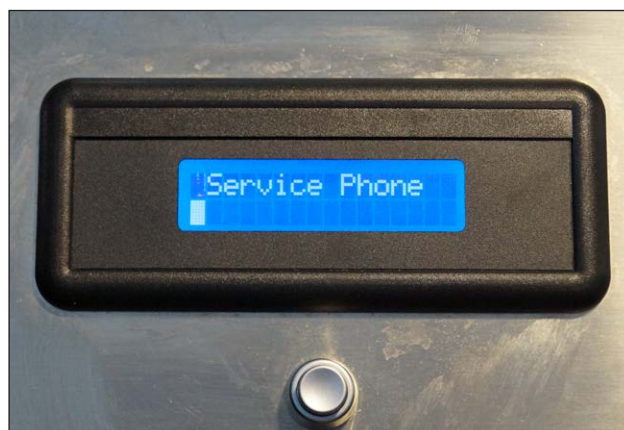

#### Groups Number

In this section, you can set the number of machine units.

- Press the button “**A**” or “**B**” to change the value. Press the button “**C**” to confirm the selection and go to the next section.



EN

**Crono function**

In this section, you can enable or disable counting in seconds of the coffee dispensing time.

- Press the button "A" or "B" to enable/disable the function.

Press the button "C" to confirm the selection and go to the next section.

**Load cells**

This section is not available on the machine.

Leave the default setting (disabled).

Press the button "C" to go to the next section.

**WATT**

The control unit is capable of controlling the machine with different powers. The power control of the individual heating elements allows setting the power (W) based on the country of use.

The selectable values are: 5700 W - 6500 W - FULL

- Press the button "A" or "B" to change the value.

Press the button "C" to confirm the selection and go to the next section.

**Probe Steam Press**

This section is optional.

If the machine is not equipped with a transducer, leave the default setting (disabled).

- Press the button "A" or "B" to change the setting.

Press the button "C" to confirm the selection and go to the next section.



**Disp Steam Press**

If this section is enabled, the steam pressure is shown on the service boiler display. If disabled, the steam temperature is shown on the same display.

- Press the button "A" or "B" to change the setting.

Press the button "C" to confirm the selection and go to the next section.

**Disp Press Gr.**

In this section, you can set display of the unit pressure (YES or NO).

- Press the button "A" or "B" to change the setting (set YES).

Press the button "C" to confirm the selection and go to the next section.

**Doses setting**

In this section, you can enable or disable programming of coffee doses.

- Set "ENABLED" to enable programming of coffee doses.
- Set "DISABLED" to disable programming of coffee doses.
- Press the button "A" or "B" to switch between "ENABLED" and "DISABLED".
- Press the button "C" to confirm the selection and go to the next section.

It is advisable to set the function to "ENABLED".

**Tea + Pump**

In this section, you can enable (YES) pump operation while dispensing tea.

- Press the button "A" or "B" to change the setting.

Press the button "C" to confirm the selection and go to the next section.



EN

**Pre-Brewing**

In this section, you can enable or disable the pre-brewing function; if the function is enabled, you can set the pre-brewing time for each type of coffee dispensing.

If the function is disabled, press the button “C” to go to the next section.

- To enable the function, use the button “A” or “B” to select the word **ENABLED** and press the button “C” to confirm the selection.
- You go to the next pages where you can set the pre-brewing time for each type of coffee dispensing.



**Pre-Brewing GR.1 dose**

In this section, you can set the pre-brewing time for each coffee dispensing for each single unit.

The default time is 3 seconds.

- Press the button “A” or “B” to change the time set.

Press the button “C” to confirm the selection and go to the next section.



**Pre-Brewing GR.1 2 doses**

This is the same setting as above, but for dispensing two doses (2 cups).

The default time is 5 seconds.

- Press the button “A” or “B” to change the time set.

Press the button “C” to confirm the selection and go to the next section.



EN



**The next sections are identical to the two previous ones, but referring to units 2 and 3.**

**Post-Brewing GR.1 1 dose**

In this section, you can set the post-brewing value (in ml) for each coffee dispensing for each single unit.

The default value is 3 ml.

- Press the button “A” or “B” to change the value set.

Press the button “C” to confirm the selection and go to the next section.



**Post-Brewing GR.1 2 doses**

This is the same setting as above, but for dispensing two doses (2 cups).

The default value is 5 ml.

- Press the button "A" or "B" to change the value set.

Press the button "C" to confirm the selection and go to the next section.

 **The next sections are identical to the two previous ones, but referring to units 2 and 3.**

**Flow Control**

This section is not available on the machine.

Leave the default setting (disabled).

Press the button "C" to go to the next section.

**Probe Sensitivity**

In this section, you can adjust the sensitivity of the temperature sensor to the type of water used.

The default value is **MEDIUM**.

- Press the button "A" or "B" to change the sensitivity.

Press the button "C" to confirm the selection and go to the next section.

**Service Cycles**

In this section, you can set after how many dispensing cycles the machine requires service.

The default value is "0".

- Press the button "A" or "B" to change the value.

Press the button "C" to confirm the selection and go to the next section.

When the set number of cycles has been reached, the service phone number appears on the display.



EN

**Temperature**

In this section, you can enable/disable boiler temperature control.

Set **“ENABLED”**.

- Press the button **“A”** or **“B”** to change the setting.

Press the button **“C”** to confirm the selection and go to the next section.



**Temperature**

In this section, you can set the temperature scale to °C or °F:

- Press the button **“A”** or **“B”** to select the scale to be used.

Press the button **“C”** to confirm the selection and go to the next section.



**Temperature Steam Boiler**

In this section, you can set the boiler steam temperature; the display shows the temperature expressed in °C and °F.

If you have set °C as temperature scale in the “Temperature” section, the °C value blinks and is hence modifiable.

- Press the button **“A”** or **“B”** to change the temperature value; the °F value will automatically be updated.

Press the button **“C”** to confirm the selection and go to the next section.

The display also shows the corresponding value in bar.



**KP KI KD**

In this section, there are specific parameters referring to the service boiler, which allow getting an excellent response from the machine.

It is recommended not to change the default values (KP = s 8.0 - KI = 0.15 - KD = 4.7).

- Press the button **“A”** or **“B”** to change the values.

Press the button **“C”** to confirm the selection and go to the next section.



EN

**PID setting**

Like the previous section, this section should as a rule not be changed (default value = 1).

- Press the button "A" or "B" to change the value. Press the button "C" to confirm the selection and go to the next section.

**Temperature Coffee Boiler**

In this section, you can set the boiler water temperature; the display shows the temperature expressed in °C and °F.

If you have set °C as temperature scale in the "Temperature" section, the °C value blinks and is hence modifiable.

- Press the button "A" or "B" to change the temperature value; the °F value will automatically be updated.

Press the button "C" to confirm the selection and go to the next section.

**KP KI KD**

In this section, there are specific parameters referring to the coffee boiler, which allow getting an excellent response from the machine.

It is recommended not to change the default values (KP = c 0.6 - KI = 0.10 - KD = 3.5).

- Press the button "A" or "B" to change the values.

Press the button "C" to confirm the selection and go to the next section.

**PID setting**

Like the previous section, this section should as a rule not be changed (default value = 6).

- Press the button "A" or "B" to change the value. Press the button "C" to confirm the selection and go to the next section.



EN

**Off set GR.1**

In this section, you can set the dispensing temperature correction value for unit 1.

- Press the button "A" or "B" to change the value. Press the button "C" to confirm the selection and go to the next section.

 **The same correction value can be set in the next sections for units 2 and 3.**



**KP KI KD**

In this section, there are specific parameters referring to the heating elements of the units, which allow getting an excellent response from the machine.

It is recommended not to change the default values (KP = g 0.6 - KI = 0.05 - KD = 3.4).

- Press the button "A" or "B" to change the values.

Press the button "C" to confirm the selection and go to the next section.



**PID setting**

Like the previous section, this section should as a rule not be changed (default value = 6).

- Press the button "A" or "B" to change the value. Press the button "C" to confirm the selection and go to the next section.



**Off set Holder 1**

In this section, you can set the temperature correction value for the filter holder of unit 1.

- Press the button "A" or "B" to change the value. Press the button "C" to confirm the selection and go to the next section.

 **The same correction value can be set in the next sections for the filter holder of units 2 and 3.**



EN

**KP KI KD**

In this section, there are specific parameters referring to the filter holders of the units, which allow getting an excellent response from the machine. It is recommended not to change the default values (KP = p 1.6 - KI = 0.06 - KD = 3.5).

- Press the button "A" or "B" to change the values.

Press the button "C" to confirm the selection and go to the next section.

**PID setting**

Like the previous section, this section should as a rule not be changed (default value = 6).

- Press the button "A" or "B" to change the value. Press the button "C" to confirm the selection and go to the next section.

**Time Inactivity**

If the machine is installed in an outdoor kiosk, the temperature is low and the machine is inactive for a few minutes, the unit temperature may drop 0.5°C or 1°C.

You can set an inactivity time beyond which the machine automatically increases the unit temperature to a value set in the next section.

- Press the button "A" or "B" to change the value. Press the button "C" to confirm the selection and go to the next section.

**Ofs Time Inactivity**

In this section, you can set the degrees of unit temperature increase in order to compensate for inactivity or a cold climate.

- Press the button "A" or "B" to change the value. Press the button "C" to confirm the selection and go to the next section.

 **This function is normally not used so set the value to "0".**



EN

**Filling up time**

In this section, you can set the water filling solenoid valve opening time; when this time has elapsed and filling has not occurred, the machine locks.

- Press the button "A" or "B" to set the time (normally 120 seconds are set).

Press the button "C" to confirm the selection and go to the next section.



**Water Filter**

In this section, you can set after how many litres of water used to dispense coffee, the water filter needs to be replaced.

The default value is 0000.

- Press the button "A" or "B" to set the litres.

When the set number of litres has been reached, the machine locks.

Press the button "C" to confirm the selection and go to the next section.



**Heating Cup**

In this section, you can enable/disable the heating cup.

- Press the button "A" or "B" to set "ENABLED" or "DISABLED".

If you have selected "DISABLED", press the button "C" to confirm the selection and go to the next section.



**Heating Cup**

If you selected "ENABLED" in the previous section, in this section you can set the % operation of the heating cup heating element.

- Press the button "A" or "B" to change the value.

Normally 50% is set; press the button "C" to confirm the selection and go to the next section.



EN

### Change Password

In this section, you can change the password to access the technician section.

- Use the button "A" or "B" to set "NO" to leave the current password or "YES" to change it:
- If you have selected "NO", press the button "C" to exit the technician menu.
- If you have selected "YES", press the button "C" to confirm the selection and go to the next section where the blinking number is the modifiable one.



To exit programming, press the button "B"; the unit displays come on and the machine goes back into operating mode.



**10.1.b Programming doses, time and pump power**

With the machine ON, hold down the button “C” until the light blinks.



Release the button and pull the joystick forward.



You access dose programming (“Dose setting” is shown on the display).



The unit starts dispensing and counting is shown on the display. When the desired dose has been reached, pull the joystick forward. Wait for the light to stop blinking; the set dose is stored.



**Time/date section**

Again with the machine ON, hold down the button "C" until the light blinks.



Release the button; "Clock adjust." is shown on the display.



Pull the joystick forward; "hour - minutes - day of the week" is shown on the display.

Press the button "A" or "B" to change the hour, confirm with the button "C" and then go on to the minutes.

Press the button "A" or "B" to change the minutes, confirm with the button "C" and then go on to the day.

Press the button "A" or "B" to change the day. Confirm with the button "C" and go to the next section.



EN

**Auto ON/OFF section**

In this section, you can set the time when the machine turns ON and OFF.

Press the button "A" or "B" to set/change the values. Confirm with the button "C" and go to the next section.



### Programming a rest day

In this section, you can set a rest day when the machine will not turn on.

Press the button “**A**” or “**B**” to change the day.  
Confirm with the button “**C**” and go to the next section.



### Counters

In this section, you can set the values of the individual pumps.

Press the button “**C**” to access the “% VAL PWM1” section.



Press the button “**A**” or “**B**” to set the pump power value. The recommended value is between 45% and 50%.

Press the button “**C**” to confirm the value and go to pump 2 (and then to pump 3 - only for 3-unit machines).

After setting the power of the last pump, press the button “**C**” to confirm and exit programming.

The machine goes back into operating mode.



### 10.2 Programming from tablet

- The machine operating settings and parameters can be set via the software pre-installed on the tablet (provided).

Programming from tablet can also be done with the machine running.

Operate as follows:

- Turn on the machine
- Start the “**Sanremo Opera Factory**” software.



- Press the “**Connect**” button to connect the tablet to the machine via Bluetooth. The tablet will search for Bluetooth devices in the area.
- Select the “**SANREMO 000XXX**” device corresponding to the machine to be programmed.

progressive machine number

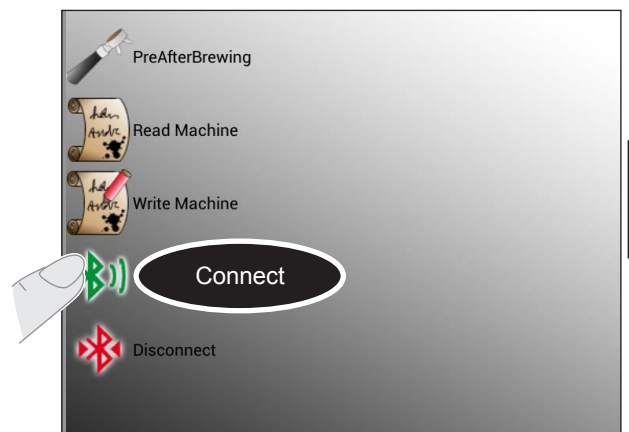

- Press the button “**Read Machine**” to load the machine data.
- Tap on the various buttons to set the desired data.

*The parameters are the same as those described in paragraph “10.1 - Programming from display” and indicated in the table on page 50/74.*

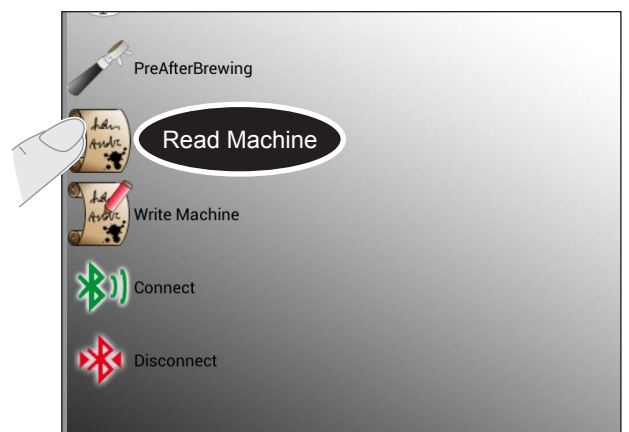

EN

- After entering/changing the data as desired, send them to the machine by pressing the **“Write Machine”** button; the machine parameters will be updated.

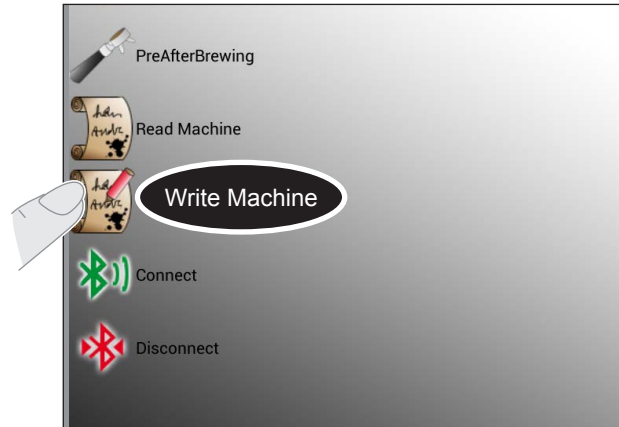

- Press the **“Disconnect”** button to disconnect the tablet from the machine.

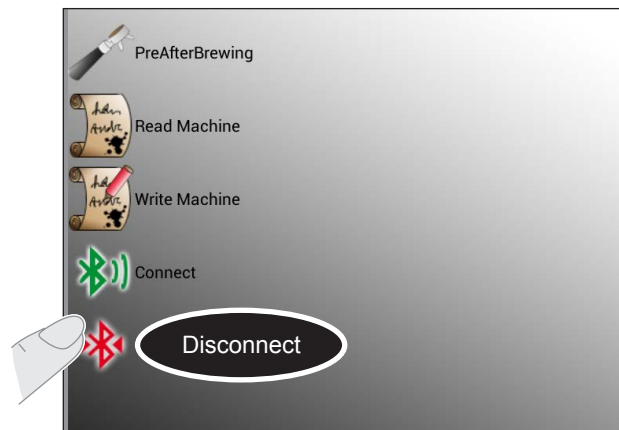

The modifiable fields are the following:

**- Text**

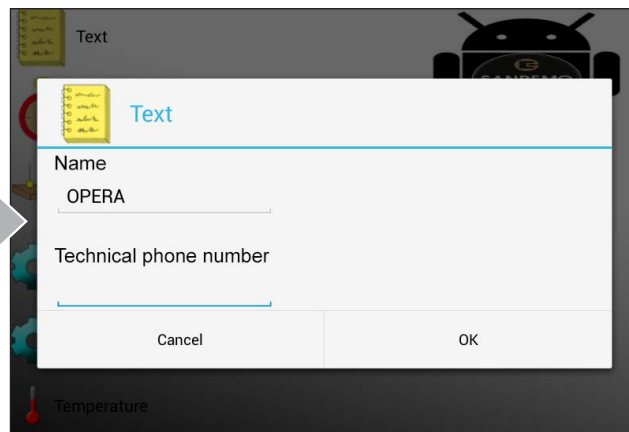
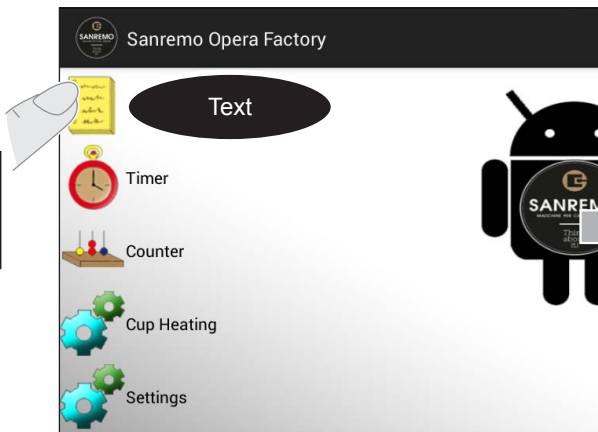

**- Timer**

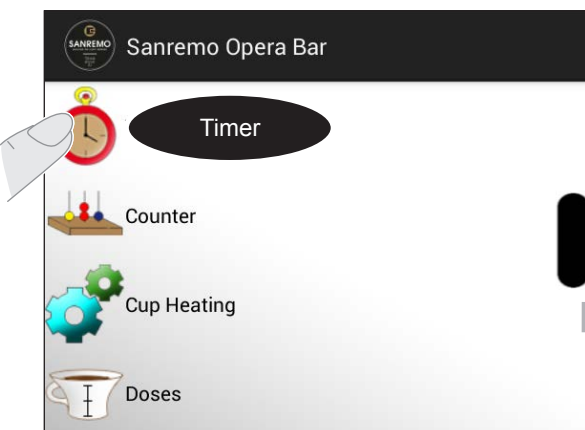

EN

- Counters

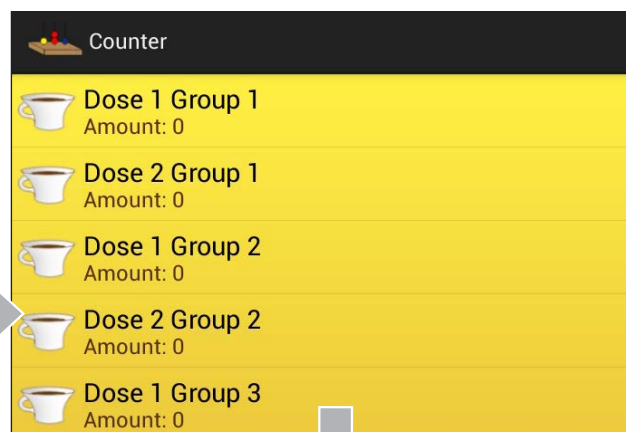
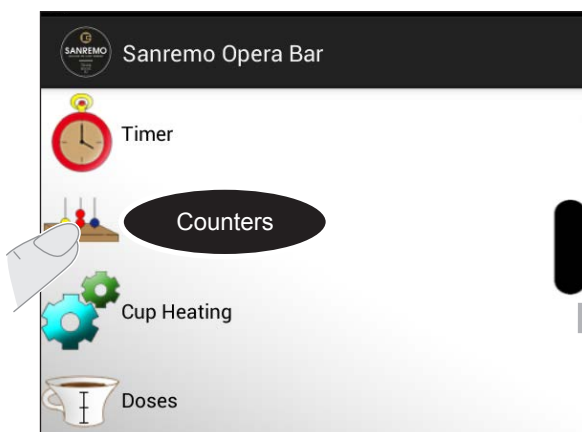

- Heating cup

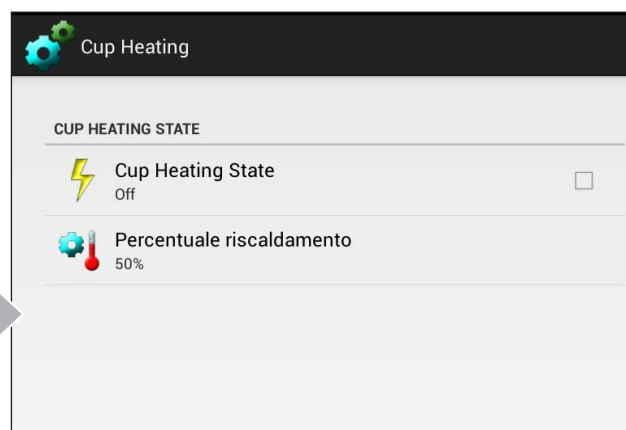
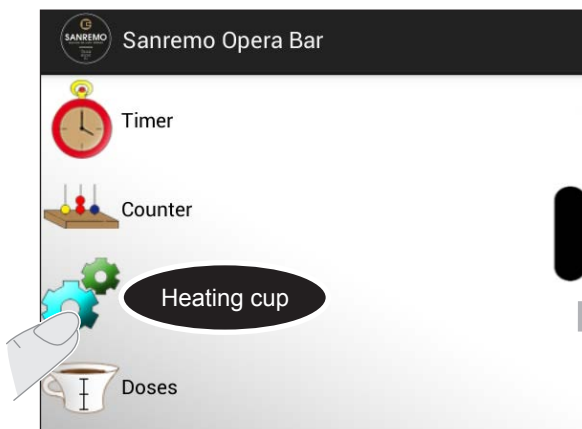

EN

- Settings

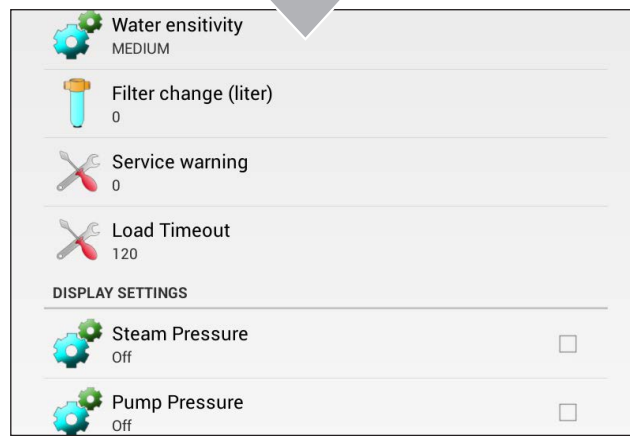
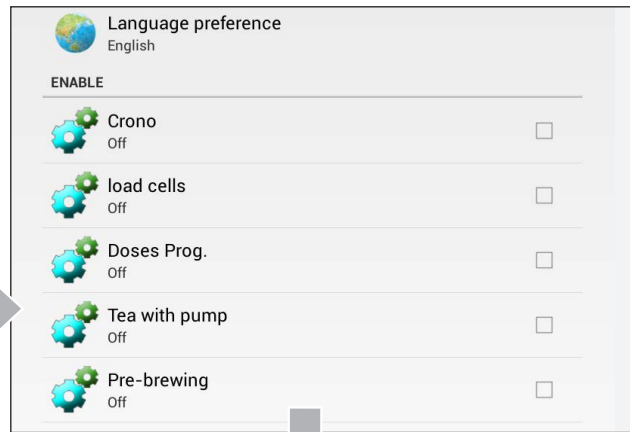
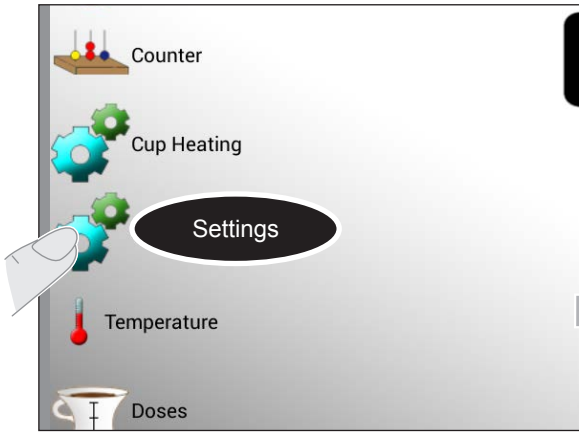

- Temperature

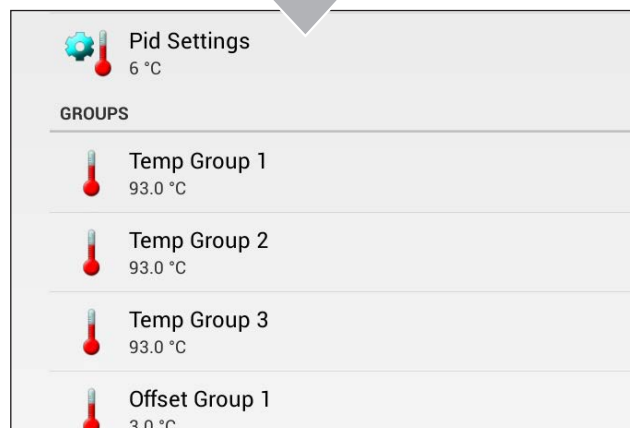
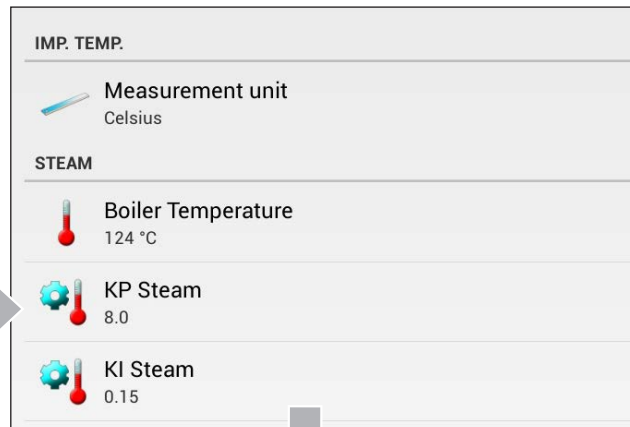
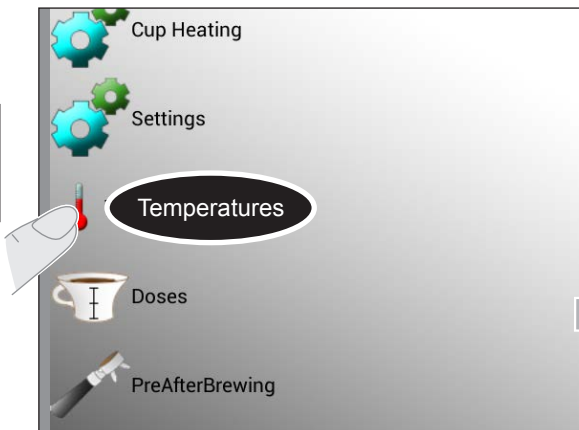

EN

- Doses

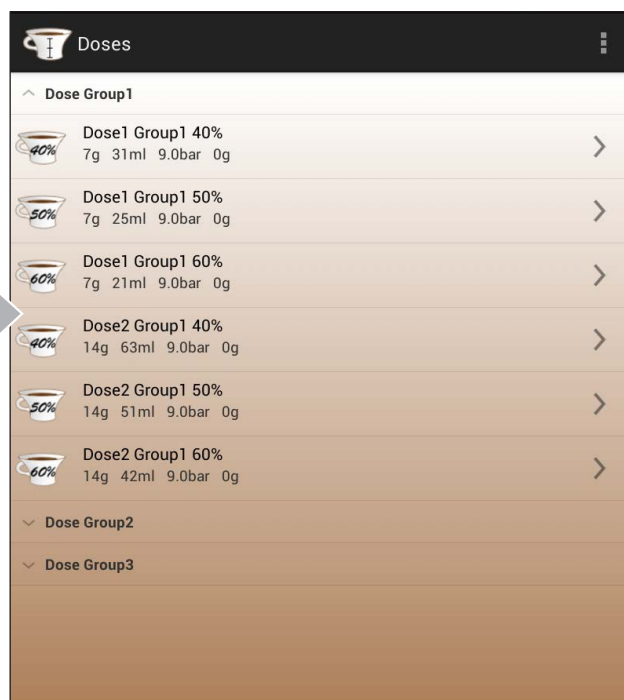
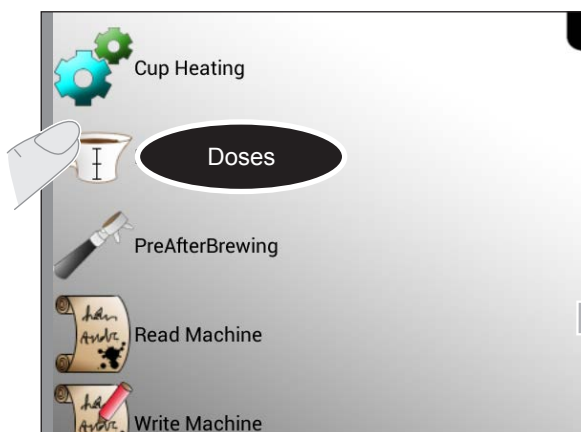

- PrePostBrewing

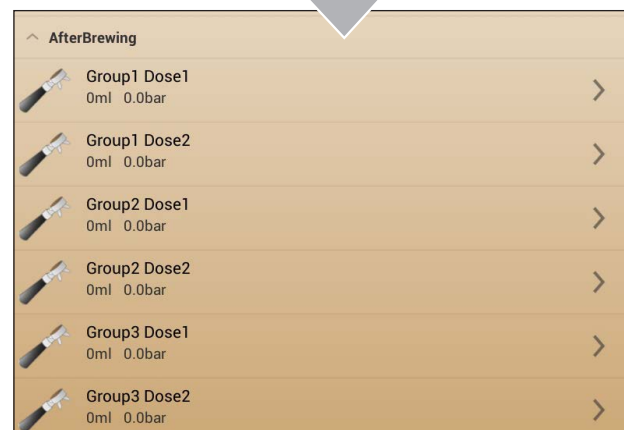
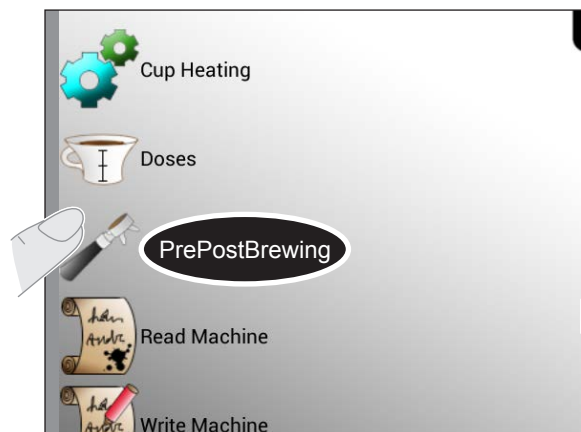

EN

### 10.3 Programming the units

Hold down the button “C” of the first unit on the left and pull the joystick forward.

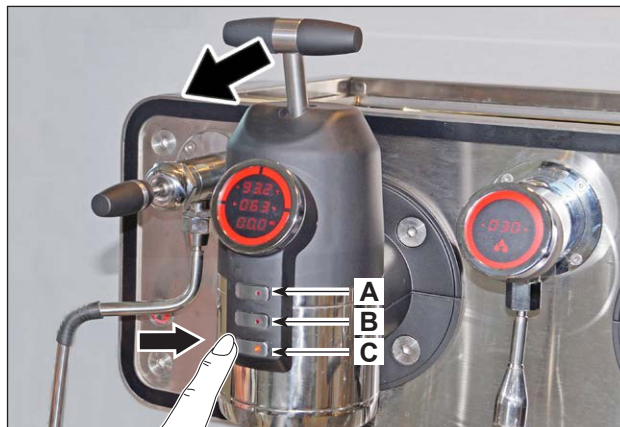

“CUP ON” is shown on the unit display.

Press the button “A” to set ON/OFF.  
Press the button “C” to confirm.



If ON is set, “050 CUP ON” is displayed (50% heating cup power).

Press the button “A” or “B” to change the value.  
Press the button “C” to confirm.



The unit heating element temperature (in °C) is shown on the display.

Press the button “A” or “B” to change the value.  
Press the button “C” to confirm.



EN

The block heating element temperature is shown on the display.

Press the button **"A"** or **"B"** to change the value.  
Press the button **"C"** to confirm and exit programming.



### 11. OPERA 2-3 UNIT - HYDRAULIC DIAGRAM

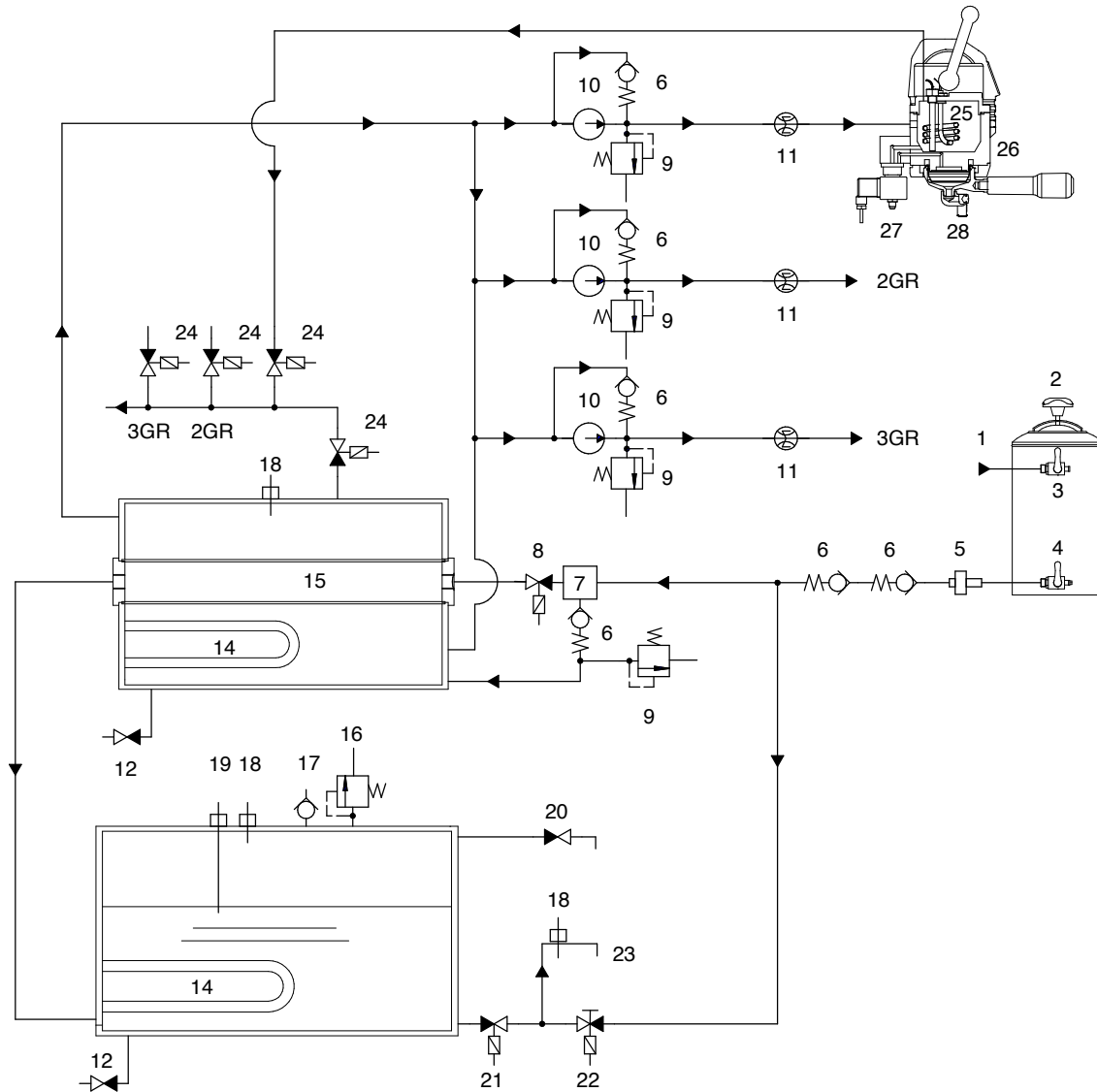

**LEGEND**

- |   |                                     |
|---|-------------------------------------|
| 1) Mains water supply                   | 15) Heat exchanger                  |
| 2) Softener                             | 16) Safety valve                    |
| 3) Water inlet tap                      | 17) Antivacuum valve                |
| 4) Water outlet tap                     | 18) Temperature probe               |
| 5) Filter                               | 19) Level probe                     |
| 6) Check valve                          | 20) Steam tap                       |
| 7) Loading flange with filter           | 21) Adjustable water solenoid valve |
| 8) Solenoid valve for automatic filling | 22) Mixed water solenoid valve      |
| 9) Expansion valve                      | 23) Hot water outlet                |
| 10) Gear pump                           | 24) Bleed solenoid valve            |
| 11) Displacement counter                | 25) Unit heating element            |
| 12) Boiler drain tap                    | 26) Dispensing unit                 |
| 13) Boiler                              | 27) Dispensing unit solenoid valve  |
| 14) Boiler heating element              | 28) Filter holder                   |

EN

## 12. WIRING DIAGRAMS

### 12.1 WIRING DIAGRAM OPERA 2-3 UNITS - SINGLE PHASE

#### LEGEND

- |   |   |
|---|---|
| 1) Power supply 1P+N+PE 400V 50Hz                         | 30) Bluetooth   |
| 2) Main relay   | 31) Pump 1  |
| 3) Main switch  | 32) Pump 2  |
| 4) Drain air switch                                       | 33) Pump 3  |
| 5) Power supply switching 25W                             | 34) Main board "OPERA"                                |
| 6) Power supply switching 150W                            | 35) Pressure transducer                               |
| 7) Tea switch   | 36) OBP programming connector                         |
| 8) Magnetic switch gr.1                                   | 37) NTC hot tea                                       |
| 9) Magnetic switch gr.2                                   | 38) NTC boiler gr.1                                   |
| 10) Magnetic switch gr.3                                  | 39) NTC boiler gr.2                                   |
| 11) Water level steam boiler                              | 40) NTC boiler gr.3                                   |
| 12) Flowmeter 1   | 41) NTC coffee boiler                                 |
| 13) Flowmeter 2   | 42) NTC resist. ring gr.2                             |
| 14) Flowmeter 3   | 43) NTC steam boiler                                  |
| 15) 3 phases relay  | 44) NTC resist. ring gr.3                             |
| 16) Safety thermostat 169 °C 3 phases                     | 45) NTC resist. ring gr.1                             |
| 17) Steam boiler 3500W                                    | 46) Cup heating 250W                                  |
| 18) Expansion board triac                                 | 47) Pressure transducer                               |
| 19) CN24 main board                                       | 48) Tea & services display in OPERA 2g                |
| 20) Group heating safety thermostat 800W 135°C 1 phase    | 49) Switching power supply 110W (2gr.) or 180W (3gr.) |
| 21) Blocks heating 160W                                   | 50) Drain air switch                                  |
| 22) 1 phase relay   | 51) External pump 230VAC - 150W 1,5A                  |
| 23) CN17 main board 1 <sup>st</sup> - 4 <sup>th</sup> pin | 52) Electric valve gr.1                               |
| 24) Safety thermostat 145 °C 1 phases                     | 53) Electric valve gr.2                               |
| 25) Coffee boiler 1200W                                   | 54) Electric valve gr.3                               |
| 26) Rings heating 13W                                     | 55) Electric valve load                               |
| 27) Display   | 56) Electric valve hot water tea                      |
| 28) Input 1 phase relay                                   | 57) Electric valve cold water tea                     |
| 29) CN7 exp. board  | 58) Electric valve steam tea                          |

## 12.2 WIRING DIAGRAM

### OPERA 2-3 UNITS - THREE PHASE

#### LEGEND

- |   |   |
|---|---|
| 1) Power supply 3P+N+PE 400V 50Hz                         | 30) Bluetooth   |
| 2) Main relay   | 31) Pump 1  |
| 3) Main switch  | 32) Pump 2  |
| 4) Drain air switch                                       | 33) Pump 3  |
| 5) Power supply switching 25W                             | 34) Main board "OPERA"                                |
| 6) Power supply switching 150W                            | 35) Pressure transducer                               |
| 7) Tea switch   | 36) OBP programming connector                         |
| 8) Magnetic switch gr.1                                   | 37) NTC hot tea                                       |
| 9) Magnetic switch gr.2                                   | 38) NTC boiler gr.1                                   |
| 10) Magnetic switch gr.3                                  | 39) NTC boiler gr.2                                   |
| 11) Water level steam boiler                              | 40) NTC boiler gr.3                                   |
| 12) Flowmeter 1   | 41) NTC coffee boiler                                 |
| 13) Flowmeter 2   | 42) NTC resist. ring gr.2                             |
| 14) Flowmeter 3   | 43) NTC steam boiler                                  |
| 15) 3 phases relay  | 44) NTC resist. ring gr.3                             |
| 16) Safety thermostat 169 °C 3 phases                     | 45) NTC resist. ring gr.1                             |
| 17) Steam boiler 3500W                                    | 46) Cup heating 250W                                  |
| 18) Expansion board triac                                 | 47) Pressure transducer                               |
| 19) CN24 main board                                       | 48) Tea & services display in OPERA 2g                |
| 20) Group heating safety thermostat 800W 135°C 1 phase    | 49) Switching power supply 110W (2gr.) or 180W (3gr.) |
| 21) Blocks heating 160W                                   | 50) Drain air switch                                  |
| 22) 1 phase relay   | 51) External pump 230VAC - 150W 1,5A                  |
| 23) CN17 main board 1 <sup>st</sup> - 4 <sup>th</sup> pin | 52) Electric valve gr.1                               |
| 24) Safety thermostat 145 °C 1 phases                     | 53) Electric valve gr.2                               |
| 25) Coffee boiler 1200W                                   | 54) Electric valve gr.3                               |
| 26) Rings heating 13W                                     | 55) Electric valve load                               |
| 27) Display   | 56) Electric valve hot water tea                      |
| 28) Input 1 phase relay                                   | 57) Electric valve cold water tea                     |
| 29) CN7 exp. board  | 58) Electric valve steam tea                          |



---

Think  
about  
it!

**SANREMO s.r.l.**  
Via Bortolan, 52  
31050 Vascon di Carbonera (TV)  
ITALIA  
tel. +39 0422 448900  
fax +39 0422 448935  
p.iva /c.f. 03239750262  
[www.sanremomachines.com](http://www.sanremomachines.com)  
[info@sanremomachines.com](mailto:info@sanremomachines.com)