



Instruction Manual

Reach-In Refrigerators & Freezers

Models: R1R-1 F1R-1
 R2R-1 F2R-1
 R3R-1 F3R-1

Supera Customer Care Toll-Free Service Line:
1-866-953-3288

For additional product and warranty information, please visit our website at
www.SuperaCo.com

Table of Contents:

1) Introduction.....	2
2) Use of the equipment.....	2
3) Technical features	3
4) Operation	3
5) Control unit	3
6) Handling	4
7) Installation procedure	4
8) Connecting to the main power supply	4
9) Maintenance instructions	6
Cleaning.....	6
Cleaning the refrigerator surface	6
Cleaning the inside of the refrigerator.....	6
Cleaning the condenser	6
10) Troubleshooting.....	7
11) Technical service	7
12) Configuration Sketch Map.....	7
Operating Instructions	8
Electrical Control Circuit Diagram	10
Technical Parameters	11
Wiring Diagram.....	12
Official Approval And Rules.....	13

1. Introduction

This instruction manual provides all the necessary information regarding:

- Use of the refrigerator
- Technical specifications
- Installation and handling
- Operator procedures and instructions
- Maintenance operation

The manual is to be considered an integral part of the refrigerator and should be stored in a safe place for further consultation for the working life of the refrigerator.



The manufacturer cannot be held liable in the following cases:

- Improper installation (*not in accordance with the guidelines indicated herein*)
- Misuse of the refrigerator
- Power supply defects
- Improper or inadequate maintenance
- Unauthorized modification or tampering
- Use of non-original (NON-OEM) spare parts
- Partial or total failure to comply with the instructions

All electrical equipment can be hazardous to health. Current standards and legal requirements must be complied with during the installation and use of any equipment.

2. Use of the Equipment

The refrigeration units are for preserving fresh perishable foodstuffs, with a built-in refrigeration unit.

The operating temperature for refrigeration is:

- Between 45°F and 33°F at room temperature of 109°F and 60% RD

The operating temperature for frozen food maintenance is:

- Between -1°F and -8°F at room temperature of +109°F and 60% RD

3. Technical Features

The refrigerator is a ventilated system; the evaporator is in a separate insulated box on the top. All the materials used in the manufacture of this unit are guaranteed to be suitable for use with foodstuffs. The gases used in the refrigerator are R134a; in the freezer for frozen food maintenance is R404a. The refrigerating circuit is in compliance with the current industry standards.

4. Operation

The gas in the refrigerating circuit is first compressed, liquefied and then evaporated in the ventilated evaporator, situated on the top of the refrigerator.

This cycle involves the absorption of heat from the air in the refrigerator compartment. The heat produced is then dissipated to the outside environment by a condenser unit located on the top of the refrigerator.

5. Control Unit

A “digital control unit” and a “main switch pilot light” in the top panel of the refrigerator operate the refrigerator.

The “main switch pilot light” is for turning on the power supply.

The green pilot light comes on to indicate that the unit is connected to the main electricity and to start operation.

The green pilot light comes off to indicate that the unit is disconnected and is not operable. The “digital control unit” is for the regulation of all parameters to provide the correct operation of the refrigerator. Please consult all parameters in the “digital control unit” section of this manual.

6. Handling

The refrigerator arrives in PET film and packed in a cardboard box on a wood pallet.

 The refrigerator must be transported and handled with care to avoid posing a hazard to persons or property. Never place a refrigerator with a built-in refrigerated unit on its side or turn it upside down as this may damage or impair operation of the refrigerated unit. **Supera** cannot be held liable for any damage or defects arising directly or indirectly from improper handling of the equipment or non-compliance with the safeguards illustrated above.



7. Installation Procedures

- Place the refrigerator in the coolest and best ventilated part of the room. Don't install the refrigerator near heat and direct sunlight sources.
- Remove the straps securing the cardboard packing. Remove the cardboard covering. Remove the PET protection film.
- Clean the refrigerator with mild detergent and then dry it with a soft cloth.

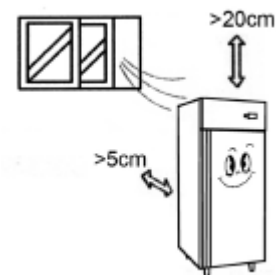

8. Connecting to the Main Power Supply

Qualified professionals must carry out this operation.

 The refrigeration units are supplied complete with a power supply cable for the connection to the main power supply. A thermomagnetic circuit breaker (*not supplied*) must be installed between the mains power point and the power supply cable of the refrigerator.

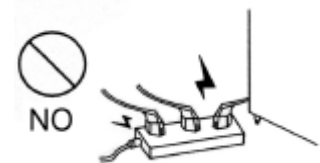

Before proceeding make sure that:

- The main voltage corresponds to the voltage on the refrigerator 115V/60Hz/1Ph; to ensure proper operation it is essential for the power supply voltage to come within a range of +/-10% of the unit's rated voltage



- The electric system to which the refrigerator is sized to cater for the rated electric output of the buffet unit being installed
- The electronic system to which the refrigerator is connected is made in compliance with current standard requirements
- The electric connections and the installation of the thermomagnetic circuit breaker have been done by qualified professionals

Connecting steps:

- Install a thermomagnetic circuit breaker suited to the rated output of the unit being installed
- Connect the refrigerator unit to the thermomagnetic circuit breaker outlet
- Check that the refrigerator is in order as demonstrated by the pilot light incorporated in the main switch coming on

9. Maintenance Instructions

The smooth operation and life of the equipment are mainly determined by correct and regular maintenance.

Cleaning:

Regular cleaning of the refrigerator unit is strongly recommended each month. Please follow the instructions below.



Disconnect the refrigerator power supply cable from the mains prior to carrying out any type of cleaning operation.

Cleaning the refrigerator surface:

Clean the refrigerator with mild detergent and then dry it with a soft cloth. Do not use abrasive detergents!



Cleaning the inside of the refrigerator:

Clean the inside area at a minimum of each month with a detergent suitable for use with foodstuffs.

Cleaning the condenser:

For an efficient operation of the refrigerator, it is advisable to clean the condenser regularly approximately every 4 months with a dry brush or vacuum cleaner.

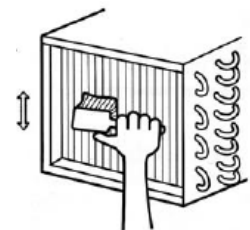

10. Troubleshooting

Refrigerator stops working (light off):

- Power supply failure

Remedies:

- Check that the plug is inserted properly
- Check that the on/off switch is set to “on”
- Check that the mains voltage power is on

Refrigerator temperature increases:

- Unit too near to a heat source
- Condenser dirty or closed

Remedies:

- Move the counter or the heat source further away
- Clean the condenser

11. Technical Service

For technical service, please contact the **Supera** Service Department and give them the serial number and the date of purchase.

12. Configuration Sketch Map

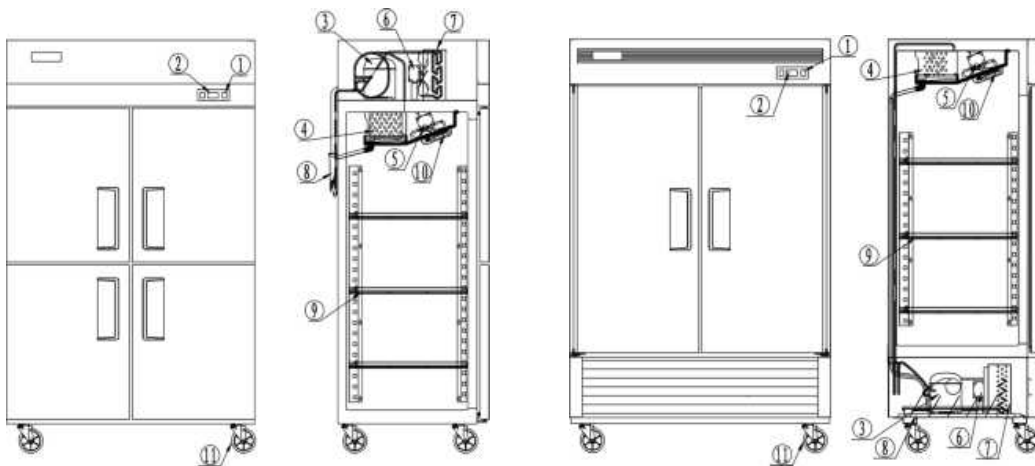

1. Power Switch
4. Evaporator
7. Condenser
10. Lamp

2. Microcomputer Controller
5. Evaporator Fan Motor
8. Drain Case
11. Casters

3. Compressor
6. Condenser Fan Motor
9. Shelf

OPERATING INSTRUCTIONS

1. New, upright air-cooling refrigeration unit should be opened and ventilated before it is in use. After that, users should use warm water clean the interior.
2. After connecting the power supply, press the “**POWER**” switch on the controller keyboard (*Green Indicator Light ON*) and the refrigeration unit’s power will turn on. The microcomputer controller, installed in the controller keyboard, can automatically adjust the temperature ranges. This intelligent digital controller works as such: If the temperature increases and reaches set point plus differential, the compressor is started and then turned off when the temperature reaches the set point value again.



FRONT PANEL COMMANDS – Digital Control Unit

SET

To display target set point, in programming mode it selects a parameter or confirm an operation.



To start a manual defrost.



In programming mode, it browses the parameter codes, or increases the displayed value.



AUX

In programming mode, it browses the parameter codes, or decreases the displayed value.

KEYS COMBINATION



+



To lock or unlock the keyboard.

SET

+



To enter in programming mode.

SET

+





To return to room temperature display.





How to See the Set Point:

1. Push and immediately release the **SET** key, the set point will be shown.
2. Push and immediately release the **SET** key or wait about 5s to return to normal visualization.

LED	MODE	SIGNIFICATO
	On	Compressor enabled
	Flashing	Anti short cycle delay enabled (AC parameter)
	On	Defrost in progress
	Flashing	Dripping in progress
	On	Fans output enabled
	Flashing	Fans delay after defrost
°C	On	Measurement unit
	Flashing	Programming mode
°F	On	Measurement unit
	Flashing	Programming mode

How to Change the Set Point:



1. Push the **SET** key for more than 2 seconds to change the Set point value.
2. The value of the set point will be displayed and the “°C” or “°F” LED starts blinking.
3. To change the Set value push the  or  arrows.
4. To memorize the new set point value push the **SET** key again or wait 10s.

How to Start a Manual Defrost:

Push the **DEF**  key for more than 2 seconds and a manual defrost will start.

How to Change a Parameter Value:



To change the parameter's value operate as follows:

1. Enter the **Programming** mode by pressing the **SET** +  keys for 3s (“°C” or “°F” LED starts blinking).
2. Select the required parameter. Press the **SET** key to display its value.
3. Use  or  to change its value.
4. Press **SET** to store the new value and move to the following parameter.



To Exit: Press **SET** +  or wait 15s without pressing a key.

NOTE: The set value is stored even when the procedure is exited by waiting the time-out to expire.

To Lock the Keyboard:

1. Keep pressed for more than 3s the  +  keys.
2. The “OF” message will be displayed and the keyboard will be locked.
3. If a key is pressed more than 3s the “OF” message will be displayed.

To Unlock the Keyboard:

Keep pressed together for more than 3s the  +  keys till the “on” message is displayed.

Alarm Signaling

Mess.	Cause	Outputs
"P1"	Room probe failure	Compressor output according to "Cy" e "Cn"
"P2"	Evaporator probe failure	Defrost end is timed
"HA"	Maximum temperature alarm	Outputs unchanged
"LA"	Minimum temperature alarm	Outputs unchanged
"EA"	External alarm	Outputs unchanged
"CA"	Serious external alarm	All outputs OFF
"dA"	Door Open	Compressor and fans restarts

Our products have been modified precisely before leaving factory, so to avoid damaging compressor unit or other malfunctions; users must not modify microcomputer parameters privately.

Electrical Control Circuit Diagram

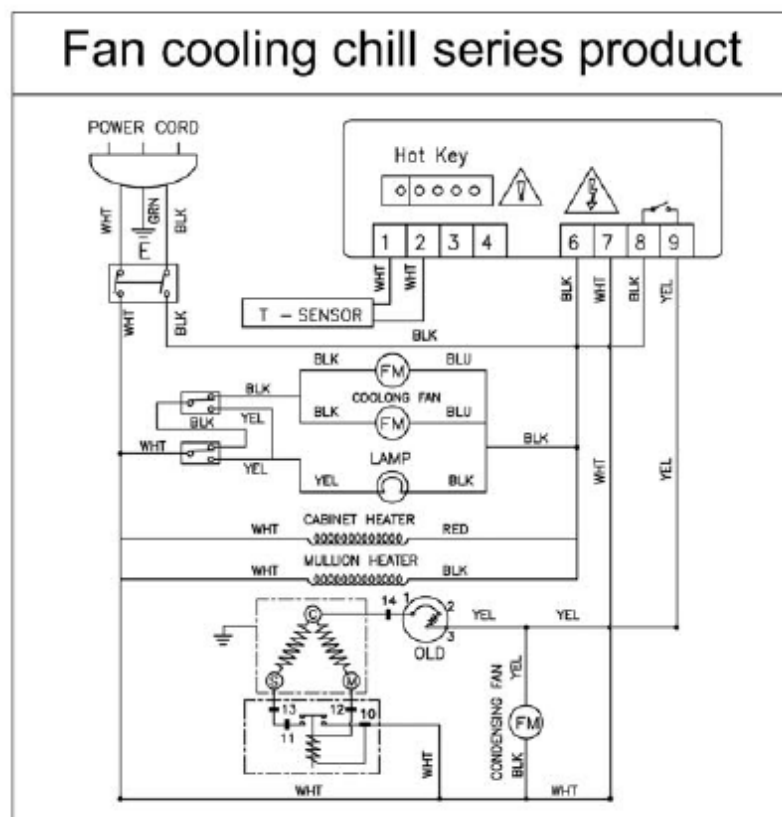

Fan cooling freeze series product

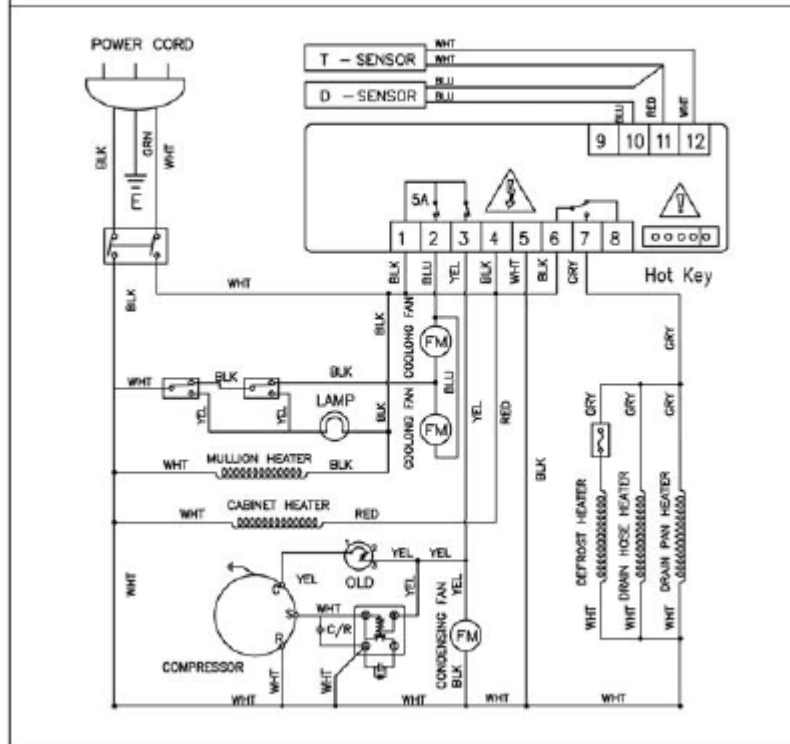

TECHNICAL PARAMETERS

Product Type	Model Name	Prevention class of getting an electric shock	Power Supply (V/Hz/Ph)	Ampers	Temperature Range(F)	Refrigerant	Dimensions (inches)	Net Weight (lb.)
Single-door Refrigerator	R1R-1	I	115/60/1	3.5	33~40	R134a	28.7x33.3x83.9	254
Two-door Refrigerator	R2R-1	I	115/60/1	5.6	33~40	R134a	51.7x33.3x83.9	419
Three-door Refrigerator	R3R-1	I	115/60/1	7.6	33~40	R134a	77.8x33.3x83.9	617
Single-door Freezer	F1R-1	I	115/60/1	6.7	-8~-1	R404a	28.7x33.3x83.9	265
Two-door Freezer	F2R-1	I	115/60/1	10.3	-8~-1	R404a	51.7x33.3x83.9	441
Three-door Freezer	F3R-1	I	208/60/1	9.6	-8~-1	R404a	77.8x33.3x83.9	617

WIRING DIAGRAM

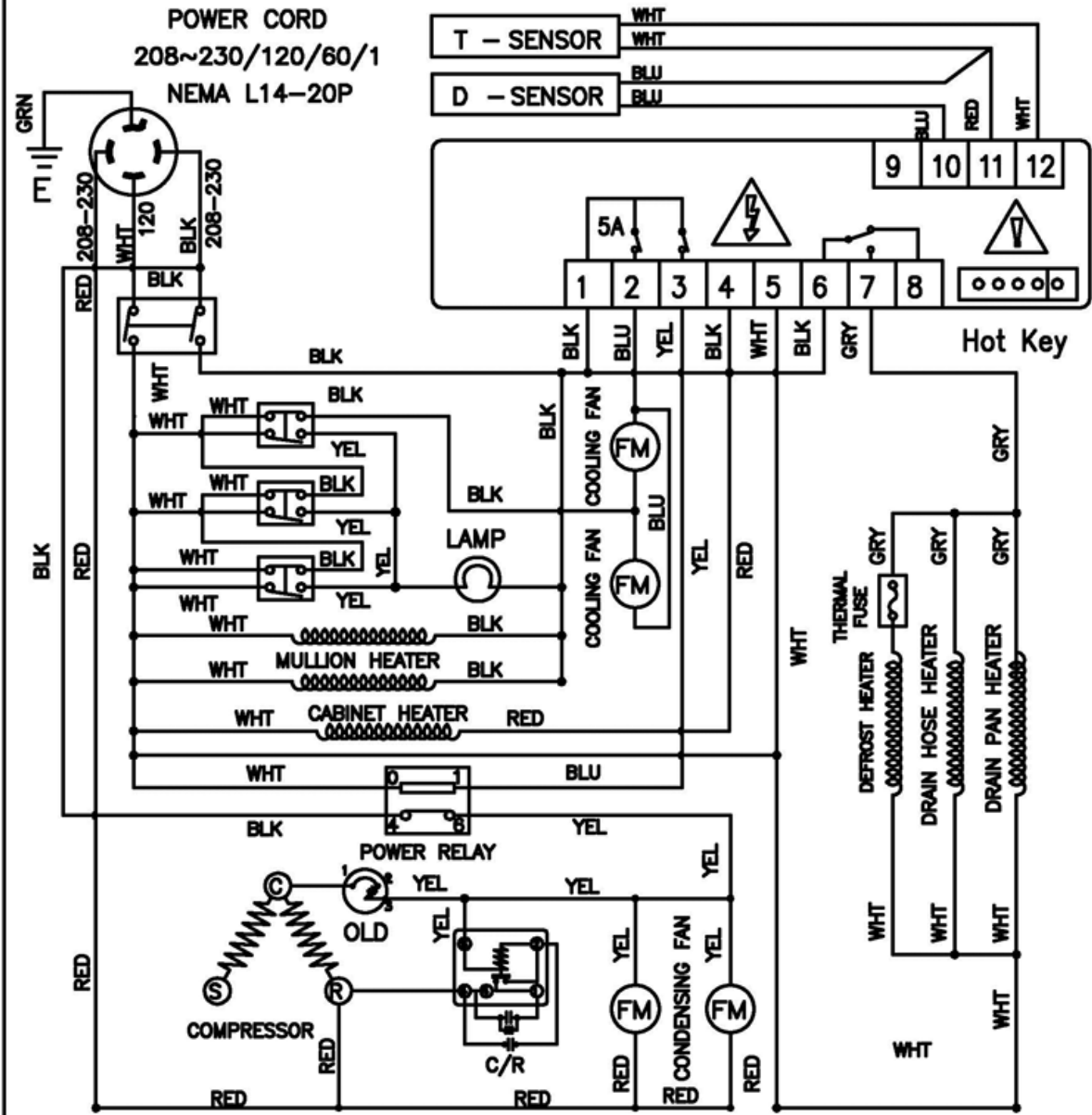

OFFICIAL APPROVALS

- Conforms to UL STD. 471
- Conforms to NSF 7
- Certified to CSA STD. C22.2 NO. 120



A product with the **SUPERA** name incorporates the best in durability and low maintenance. We all recognize, however, that replacement parts and occasional professional service may be necessary to extend the useful life of this unit. When service is needed, contact a **SUPERA** Authorized Service Agency, or your dealer. To avoid confusion, always refer to the model number, serial number, and type of your unit.



Supera Customer Care Toll-Free Service Line:

1-866-953-3288

For additional product and warranty information,
please visit our website at www.SuperaCo.com