



First in Cooking, Built to Last.

southbend

A MIDDLEBY COMPANY

IMPORTANT
FOR FUTURE REFERENCE
 Please complete this information
 and retain this manual for the life
 of the equipment.
 MODEL # _____
 SERIAL # _____
 DATE PURCHASED _____

OPERATOR'S MANUAL

INSTALLATION
OPERATION AND MAINTENANCE INSTRUCTIONS

STOCK POT RANGE

MODEL: SPR-1, SPR-2, and SPR-3

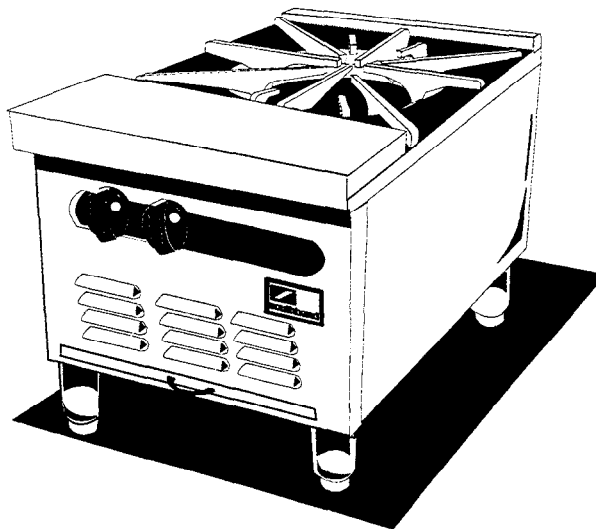

WARNING

Improper installation, adjustment, alteration, service, or maintenance can cause property damage, injury or death. Read the installation, operation and maintenance instructions thoroughly before installing and operating this equipment.

1100 Old Honeycutt Road · Fuquay-Varina, NC 27526

☎ (919) 552-9161 • (800) 348-2558

Fax (800) 625-6143 • (919) 552-9798

Middleby Corp. Service Hot Line (800)238 8444 (after hours)



\$18.00

**COUNTER STEAMER
(MANUAL SECTION SR)**

SAFETY PRECAUTIONS

Before installing and operating this equipment, be sure everyone involved in its operation is fully trained and aware of precautions. Accidents and problems can be caused by failure to follow fundamental rules and precautions.

The following symbols, found throughout this manual, alert you to potentially dangerous conditions to the operator, service personnel, or to the equipment.



This symbol warns of immediate hazards which will result in severe injury or death.



This symbol refers to a potential hazard or unsafe practice which could result in injury or death.



This symbol refers to a potential hazard or unsafe practice which could result in injury, product, or property damage.



This symbol refers to information that needs special attention or must be fully understood, even though not dangerous.

POST IN PROMINENT LOCATION

The emergency telephone number of your gas supplier and instructions to follow if gas odor is detected.

DANGER **EXPLOSION HAZARD**

If a gas odor is detected, shut down equipment at the main shut-off valve.
Immediately call the emergency phone number of your gas supplier.

FOR YOUR SAFETY

Do not store or use gasoline or other flammable vapors and liquids in the vicinity of this or any other appliance.

Keep area around appliances free and clear of combustibles.

WARNING

Asphyxiation can result from improper ventilation. Do not obstruct the flow of combustion and ventilation air to and from your cooking equipment.

NOTICE

Be sure the Operator's Manual and important papers are given to the proper authority to retain for future reference.

Congratulations! You have purchased one of the finest pieces of heavy-duty commercial cooking equipment on the market.

You will find that your new equipment, like all Southbend equipment, has been designed and manufactured to meet the toughest standards in the industry. Each piece of Southbend equipment is carefully engineered and designs are verified through laboratory tests and field installations. With proper care and field maintenance, you will experience years of reliable, trouble-free operation. **For best results, read this manual carefully.**

RETAIN THIS MANUAL FOR FUTURE REFERENCE.

TABLE OF CONTENTS:

Safety Precautions.....	inside front cover
Specifications.....	2
Installation.....	3-7
Operation.....	8
Adjustments.....	9
Maintenance.....	10
Parts/Accessories.....	11-16
Warranty.....	17

Location of serial and identification plates:

The serial plate with all the specifications is located at the rear of the unit on back panel. Reference part number 1179452 in parts section "main body components" of this manual. There is also a product identification plate that has only the model and serial number attached to the front upper right corner of the valve control panel.

Read these instructions carefully before attempting installation. "Installation" and "Start Up" should be performed by a qualified installer. Unless the installation instructions for the above-described Southbend product are followed and performed by a qualified service technician (a person experienced in and knowledgeable with the installation of commercial gas and/or electric cooking equipment) then the terms and conditions of the Manufacturer's Limited Warranty will be rendered void and no warranty of any kind shall apply.

In the event you have questions concerning the installation, use, care, or service of the product, write to the Technical Service Department, Southbend, 1100 Old Honeycutt Road., Fuquay-Varina, North Carolina 27526.

NOTICE

This product is intended for commercial use only; not for household use.

IMMEDIATELY INSPECT FOR SHIPPING DAMAGE

All containers should be examined for damage before and during unloading. The freight carrier has assumed responsibility for its safe transit and delivery. If damaged equipment is received, either apparent or concealed, a claim must be made with the delivering carrier.

A) Apparent damage or loss must be noted on the freight bill at the time of delivery. The freight bill must then be signed by the carrier representative (Driver). If the bill is not signed, the carrier may refuse the claim. The carrier can supply the necessary forms.

B) A request for inspection must be made to the carrier within 15 days if there is concealed damage or loss that is not apparent until after the equipment is uncrated. The carrier should arrange an inspection. Be certain to hold all contents plus all packing material.



1100 Old Honeycutt Road
 Fuquay-Varina, NC 27526
 ☎ (919) 552-9161
 ☎ (800) 348-2558
 FAX (919) 625-6143
 FAX (919) 552-9798

SPECIFICATIONS

NOTE: Not for Scale. For Dimensional Purposes Only.

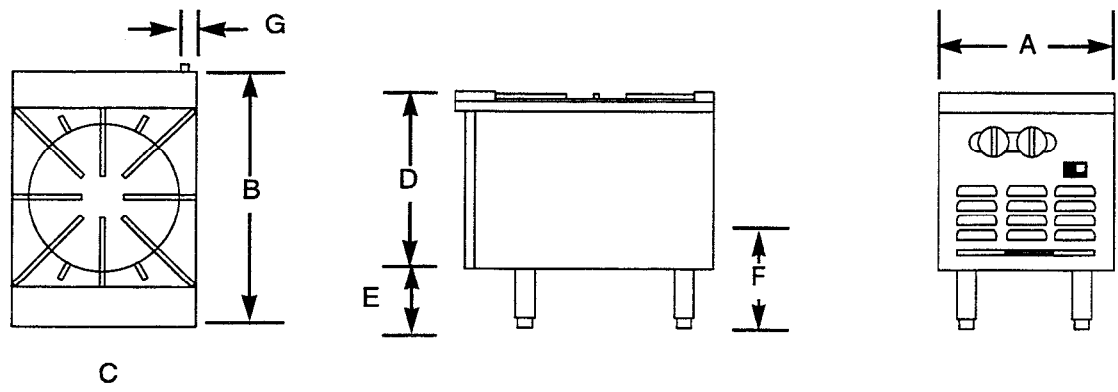

TOP VIEW

SIDE VIEW

FRONT VIEW

Dimensions:

() = Millimeters

MODEL	EXTERIOR						CUBIC VOLUME	CRATED WEIGHT	
	A Width	B Depth	C	D	E	F			G
SPR-1	18.25" (463)	26" (669)	18.5" (463)	24" (609)	6" (152)	11.75" (254)	1" (60)	23 cu. ft (.65 cu. m.)	210 lbs. (95.28 kg)

NOTE: Above dimensions are for single Stock Pot Ranges. SPR-2 Double and SPR-3 Triple Stock Pot Ranges are shipped assembled at factory and above dimensions are different.

UTILITY INFORMATION:

One 3/4" connection required for each individual Range or each range in a battery of two or three.

GAS TYPE	INNER RING	OUTER RING
Natural	56,000 BTU	64,000 BTU
Propane	48,000 BTU	62,000 BTU

REQUIRED OPERATING PRESSURE:
 Natural Gas 4" W.C.; Propane Gas 10" W.C.

A 3/4" gas pressure regulator is standard with each stock pot range section.

NOTICE

Southbend reserves the right to change specifications and product design without notice. Such revisions do not entitle the buyer to corresponding changes, improvements, additions, or replacements for previously purchased equipment.

NOTICE

These procedures must be followed by qualified personnel or warranty will be void.

GENERAL:

NOTICE

The unit, when installed, must conform with local codes, or in the absence of local codes, with the National Fuel Gas Code, ANSI Z223.1-latest edition.

GAS CONNECTION:

The Serial Plate is located at the rear of the unit on the back panel. It indicates the type of gas the unit is equipped to burn.

All Southbend equipment is adjusted at the factory but may need a finish adjustment once installed. Check type of gas on serial plate.

These models are design-certified for operation on natural or propane gases.

This appliance should be connected **ONLY** to the type of gas for which it is equipped.

Add supply requirement, i.e. pipe size, pressure regulator information, operating pressure WC - natural and propane when all units on line are operating simultaneously.

An adequate gas supply is imperative. Undersized or low pressure lines will restrict the volume of gas required for satisfactory performance. Fluctuations of more than 25% on natural gas or 10% on propane gas will create problems and affect burner operating characteristics. A 1/8" pressure tap is located on the manifold to measure the manifold pressure.

An adequate gas supply line to the unit should be no smaller than the I.D. of the pipe from the unit to which it is connected.

Purge the supply line to clean out dust, dirt, or other foreign matter before connecting the line to the unit.

All pipe joints and connections must be tested thoroughly for gas leaks. Use only soapy water for testing on all gases. **NEVER** use an open flame to check for gas leaks. All connections must be checked for leaks after the unit has been put into operation. Test pressure should not exceed 1/4" W.C.

For Natural gas the regulator is set to deliver a 4" W.C. pressure to the manifold. For Propane gas it is set to deliver 10" W.C.



CAUTION

This appliance and its individual shutoff valve must be disconnected from the gas supply piping system during any pressure testing of that system at test pressures in excess of 1/2 PSIG (3.45 KPA).

This appliance must be isolated from the gas supply piping system by closing its individual manual shutoff valve during any pressure testing of the gas supply piping system at test pressure equal to or less than 1/2 PSIG (3.45KPA).

If this equipment is being installed at over 2,000 feet altitude and was not specified on order, contact the appropriate authorized Southbend Service Representative or the Southbend Service Department. Failure to install with proper orifice sizing will result in improper performance and may void the warranty.

NOTICE

If applicable, the vent line from the gas appliance pressure regulator should be installed to the outdoors in accordance with local codes or, in the absence of local codes, with the National Fuel Gas Code, ANSI Z223. 1-latest edition.

INSTALLATION

CLEARANCES:

Minimum Clearances -- Inches (mm)

	From Combustible Construction	From Non-Combustible Construction
Back	-	8 inches
Right Side	-	0
Left Side	-	0
Floor	-	0

NOTE: For use in noncombustible locations only.

All units must be installed in such a manner that the flow of combustion and ventilation air are not obstructed. Provisions for an adequate air supply must be provided. Do not obstruct the front or rear of the unit, as combustion air enters through this area. Be sure to inspect and clean the ventilation system according to the ventilation equipment manufacturer's instructions.

No additional clearance from the sides and back is required for service as the units are serviceable from the front.

DO NOT MOUNT ABOVE OTHER COOKING EQUIPMENT.

NOTICE

Local codes regarding installation vary greatly from one area to another. The National Fire Protection Association, Inc. states in its NFPA 96 latest edition that local codes are the "authority having jurisdiction" when it comes to installation requirements for equipment. Therefore, installations should comply with all local codes.

EXHAUST FANS AND CANOPIES: Canopies are set over ranges, ovens, etc., for ventilation purposes. It is recommended that a canopy extend 6" past the appliance and the bottom edge be located 6'6" from the floor. Filters should be installed at an angle of 45 degrees or more from horizontal. This position prevents dripping grease and facilitates collecting the run-off grease in a drip pan, usually installed with a filter. A strong exhaust fan tends to create a vacuum in the room and may interfere with burner performance or may extinguish pilot flames. Fresh air openings approximately equal to the fan area will relieve such a vacuum.

WALL EXHAUST FAN: The exhaust fan should be installed at least 2" above the vent opening at the top of the unit.

In case of unsatisfactory performance on any appliance, check the appliance with the exhaust fan in the "OFF" position. Do this only long enough to check equipment performance. Then turn hood back on and let it run to remove any exhaust that may have accumulated during the test.

NOTICE

Proper ventilation is the owner's responsibility. Any problem due to improper ventilation will not be covered by warranty.



WARNING

Improper ventilation can result in personal injury or death. Ventilation which fails to properly remove flue products can cause headaches, drowsiness, nausea, or could result in death.

LEVELING:

Unit must be level to assure maximum performance. Improper leveling may void warranty.

TO INSTALL STOCK POT RANGE:

1. Remove unit from packaging.
2. Shipped with every unit should be a leg package containing four legs. Two of which will have flanges for bolting them to the floor. These legs are to be installed on the rear of the unit. These are labeled (Item "E") in figure 1. The other adjustable legs are to be installed on the front of the unit.
3. Leg pads (Item "C") in figure 1 have already been installed on the bottom of the unit. To install legs simply screw legs into leg pads on bottom of unit.
4. Once the unit has been moved into position adjust front and rear adjusters in bottom of legs until unit is level. Make sure unit is leveled front to back and side to side. It is very important that this unit be level.
5. Once the unit has been leveled attach the flanged feet to the floor using appropriate fasteners.

NOTICE

This unit **MUST** be attached to the floor by means of the flanged feet at the rear of the unit. Failure to do so may create a tip hazard which could result in injury to the operator or damage to the unit. Failure to install properly will void the manufacturer's warranty.

INSTALLATION

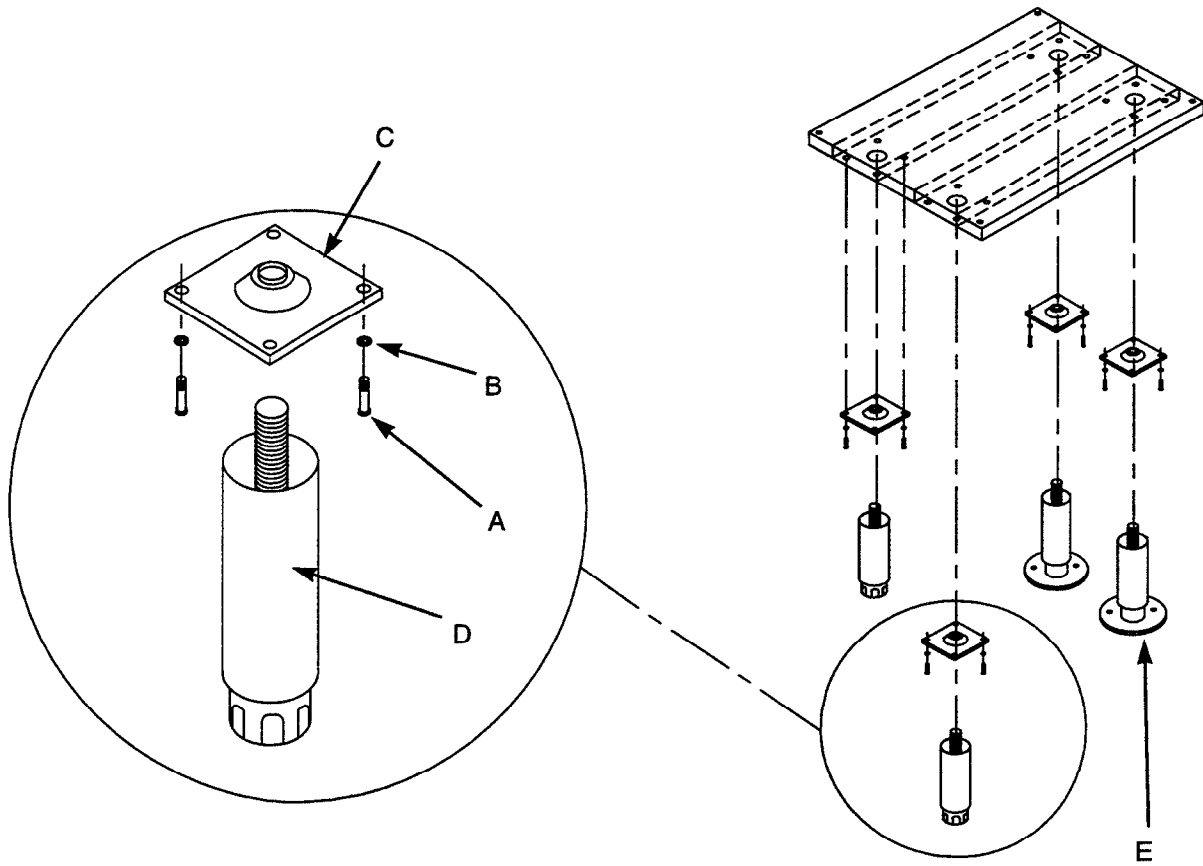

FIGURE 1

LEG ASSEMBLY

ITEM	PART NUMBER	QTY per Unit	DESCRIPTION
A	1146201	16	1/4 -20 x 3/4 Hex Head
B	1146500	16	1/4 Lock Washer
C	1172650	4	Leg Pad (3/4-10 hole)
*D	1179510	2	S.S. Leg (3/4-10 stud)
*E	1179510	2	S.S. Earth Quake Leg (3/4-10 stud)

NOTE: Items A, B, and C are installed at the factory. Items D and E are to be installed in field. Flanged feet (item E) must go on to the rear of the unit.

* 1179510 is a leg package consisting of 2 standard legs and 2 flanged legs.

PERFORMANCE CHECK:

The following items should be checked within the first 30 days of operation by a qualified service technician.

1. Verify equipment is level.
2. Check ventilation.
3. Check timers, switches and motor for proper installation and operation.
4. Check for any damage to unit from shipping or installation.
5. Check for proper clearance from combustible materials.
6. Verify proper type of gas
7. Verify gas supply and pressure (pressure regulator is already installed at factory.)
8. Check gas connection and check for leaks.

It is common for new products to require a burn-off time to dry out insulation and metal cooking surfaces.

THEORY OF OPERATION

TO LIGHT STANDING PILOT:

1. Locate pilot adjustment screw. This is located between the burner valves and is accessible through the slotted hole in the control panel.
2. Verify the gas supply line is connected and gas is being supplied to the unit.
3. Light pilot and verify that the pilot flame is approximately 1/4 " high.
4. If pilot is too low turn pilot adjustment screw counter clockwise to increase the pilot flame. If pilot is too high turn pilot adjustment screw clockwise to lower pilot flame.

CAUTION

To eliminate gas buildup which could result in explosion:

In the event of main burner ignition failure, a five minute purge period with gas controls in the "off" position must be observed prior to reestablishing ignition source.

OPERATION

DANGER EXPLOSION HAZARD

In the event a gas odor is detected, shut down equipment at the main shut off valve. Immediately call the emergency phone number of your gas supplier.

WARNING BURN OR EXPLOSION HAZARD

Open burners must be installed a minimum of 16" from a deep fat fryer. Splatter of grease into an open flame can result in fire. Splatter of water into grease can cause explosions and severe burns.

NOTE: Optional wok to be used on center ring burner only.

ADJUSTMENTS

NOTICE

Service work should be performed only by a qualified technician who is experienced in, and knowledgeable of, the operation of commercial gas, electric, and steam cooking equipment. Contact the Authorized Southbend Service Agency for reliable service, dependable advice or other assistance, and for genuine factory parts.

Warranty will be void and the manufacturer is relieved of all liability if:
(A) Service work is performed by other than a qualified technician.
OR
(B) Other than genuine Southbend replacement parts are installed.

TO ADJUST PILOT

1. Open gas supply line shutoff valve.
2. Open pilot adjustment screw (located behind the control panel, accessible through a hole in the control panel) until pilot flame is approximately 1/4" high above pilot hood.

WARNING

Adjustments and service work may be performed only by a qualified technician who is experienced in, and knowledgeable with, the operation of commercial gas cooking equipment. However, to assure your confidence, contact your authorized Southbend service agency for reliable service, dependable advice or other assistance, and for genuine factory parts.

At least twice a year, have your Southbend Authorized Service Agency or another qualified service technician clean and adjust the unit for maximum performance.

Consult the Southbend Authorized Parts/Service Distributor list for the Authorized Service Representative in your area. If this is not available, call the Service Department at Southbend, 1-800-348-2558 for their name and number.

SERVICE

MAINTENANCE

Southbend equipment is sturdily constructed of the best materials and is designed to provide durable service when treated with ordinary care. To expect the best performance, your equipment must be kept in good condition and cleaned daily. Naturally, the periods for this care and cleaning depend on the amount and degree of use.

Following daily and periodic maintenance procedures will enhance the long-life of your equipment. Climatic conditions (salt air, seasonings, water quality) may require more thorough and frequent cleaning or the life of the equipment could be adversely affected.

Daily: Wash exposed cleanable areas.

Monthly: Clean around burner air mixers, louvered panels, and pilots where grease or lint may have accumulated.

EXTERIOR:

STAINLESS STEEL: To remove normal dirt, grease, or product residue from stainless steel, use ordinary soap and water (with or without detergent) applied with a sponge or cloth. Dry thoroughly with a clean cloth. Never use vinegar or any corrosive cleaner.

To remove grease and food splatter or condensed vapors that have baked onto the equipment, apply cleanser to a damp cloth or sponge and rub cleanser on the metal in the direction of the polishing lines on the metal. Rubbing cleaners as gently as possible in the direction of the polished lines will not mar the finish of the stainless steel. **NEVER RUB in A CIRCULAR MOTION.** Soil and burnt deposits which do not respond to the above procedure can usually be removed by rubbing the surface with SCOTCH-BRITE scouring pads or STAINLESS scouring pads. **DO NOT USE ORDINARY STEEL WOOL,** as any particles left on the surface will rust and further spoil the appearance of the finish. **NEVER USE A WIRE BRUSH, STEEL SCOURING PAD (EXCEPT STAINLESS), SCRAPER, FILE OR OTHER STEEL TOOLS.** Surfaces which are marred collect dirt more rapidly and become more difficult to clean. Marring also increases the possibility of corrosive attack. Refinishing may then be required.

CONTROL PANEL: The textured control panel should be cleaned with warm water and mild soap. Never use cleaning solvents with a hydrocarbon base.

VENT SYSTEM: At least twice a year, the unit's venting system should be examined and cleaned.

DAILY CLEANING

Remove the pan supports and well cover. Wash separately in a sink with a mild detergent and warm water. Dry thoroughly with a clean cloth.

Wash interior surfaces, with a mild detergent and warm water. Rinse with clean water. Dry thoroughly with a clean cloth. If discoloration starts due to build up of seasonings or food products, remove by using Scotch-Brite scouring pad. Then wash, rinse, and dry as above.

Wipe exterior surface with a clean damp cloth.

Return all cleaned parts to the unit, placing them in their proper positions.

HELPFUL HINT:

To remove heat tint: Darkened areas sometimes appear on stainless steel surfaces where the area has been subjected to excessive heat. These darkened areas are caused by a thickening of the protective surface of the stainless steel and are not harmful. Heat tint can normally be removed by the foregoing, but tint which does not respond to this procedure calls for a vigorous scouring in the direction of the polish lines using SCOTCH-BRITE scouring pads, or a STAINLESS scouring pad in combination with a powdered cleaner. Heat tint action may be lessened by not applying or by reducing heat to equipment during slack periods.

CAUTION

DO NOT USE ordinary steel wool as any particles left on the surface will rust.

NEVER USE a wire brush, steel or abrasive scouring pad (except stainless), scraper, file or other steel tools. Surfaces which are marred collect dirt more rapidly and become more difficult to clean. Marring also increases the possibility of corrosive attack.

NEVER use any corrosive cleaner. Use only cleaners approved for stainless steel.

PARTS -- ACCESSORIES

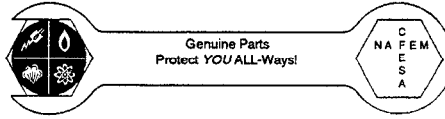

NOTICE

INSTALLATION OF OTHER THAN GENUINE SOUTHBEND PARTS WILL VOID THE WARRANTY ON THIS EQUIPMENT.

The serial plate with voltage, model, and serial information is located at the rear of the unit on the back panel. Refer to part number 1179452 in parts section "main body components" of this manual. There is also an Identification Plate mounted to the front of the upper right corner that will supply model and serial number.

Replacement parts may be ordered either through a Southbend Authorized Parts Distributor or a Southbend Authorized Service Agency.

When ordering parts, please supply the Model Number, Serial Number, Part Number, Description, Finish, and Electrical Characteristics as applicable.

Consult the Southbend Authorized Parts/Service Distributor list for the Authorized Parts supplier in your area. If this list is not available, call the Service Department at Southbend, 1-800-348-2558 for same.

MISCELLANEOUS PARTS

PART NUMBER	DESCRIPTION
1177129	Operator's/Technical Manual

PARTS

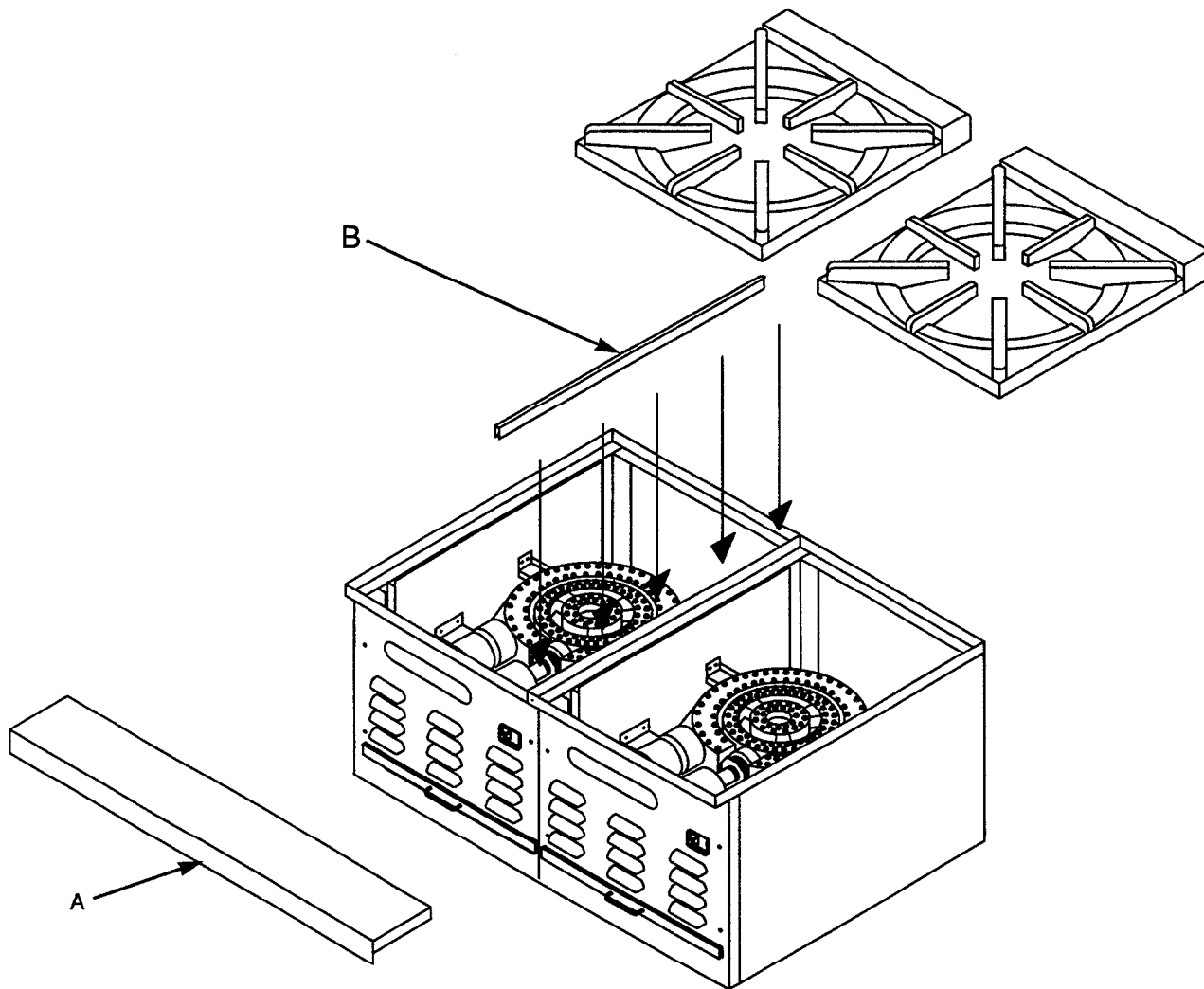

FIGURE 2

MISCELLANEOUS PARTS TO ATTACH (2) SPR-1 UNITS

Refer to figure 2 for parts list below.

ITEM	PART NUMBER	QUANTITY	DESCRIPTION
A (Double)	1179474	1	Front Rail (36")(SPR-2)
* (Single)	1179445	1	Front Rail (18")(SPR-1)
* (Triple)	1179479	1	Front Rail (54")(SPR-3)
B	1179473	1 (per pair)	Filler Strip, Top Grate Frame
*	1146201	3	Bolt, 1/4-20 x 3/4 Hex
*	1146500	3	Washer 14, Lock
*	1146507	3	Washer 1/4, Flat
*	1146413	3	Nut 1/4-20, Hex

* SPR-2 requires 3 per pair of units. SPR-3 requires 6 total.

MAIN BODY COMPONENTS

Refer to figure 3 for parts list below.

ITEM	PART NUMBER	QUANTITY	DESCRIPTION
A	1179425	1	Grate
B	1179459	1	Base Weld Asm.
C	1179458	1	Control Panel
D	1172715	1	Southbend Logo Plate
E	1173957	2	Lock Nuts
F	1179463	1	Dirt Tray Asm.
G	1179445	1	Front Rail (18")
H	1179455	2	Support, Control Panel
I	1179511	1	Body Side, Left
J	1179512	1	Body Side, Right
K	1179516	2	Support, Vertical, Asm.
L	1179515	2	Support, Vertical, Asm.
M	1179456	1	Side Liner, Left
N	1179453	1	Valve Shield
O	1179442	1	Burner Support, Front
P	1179443	1	Burner Support, Rear
Q	1179452	1	Wall, Rear
R	1179467	1	Frame Grate
S	1179472	2	Filler Strip for Side Liner
T	1179519	1	Shield, Screw
U	1179477	1	Side Liner, Right

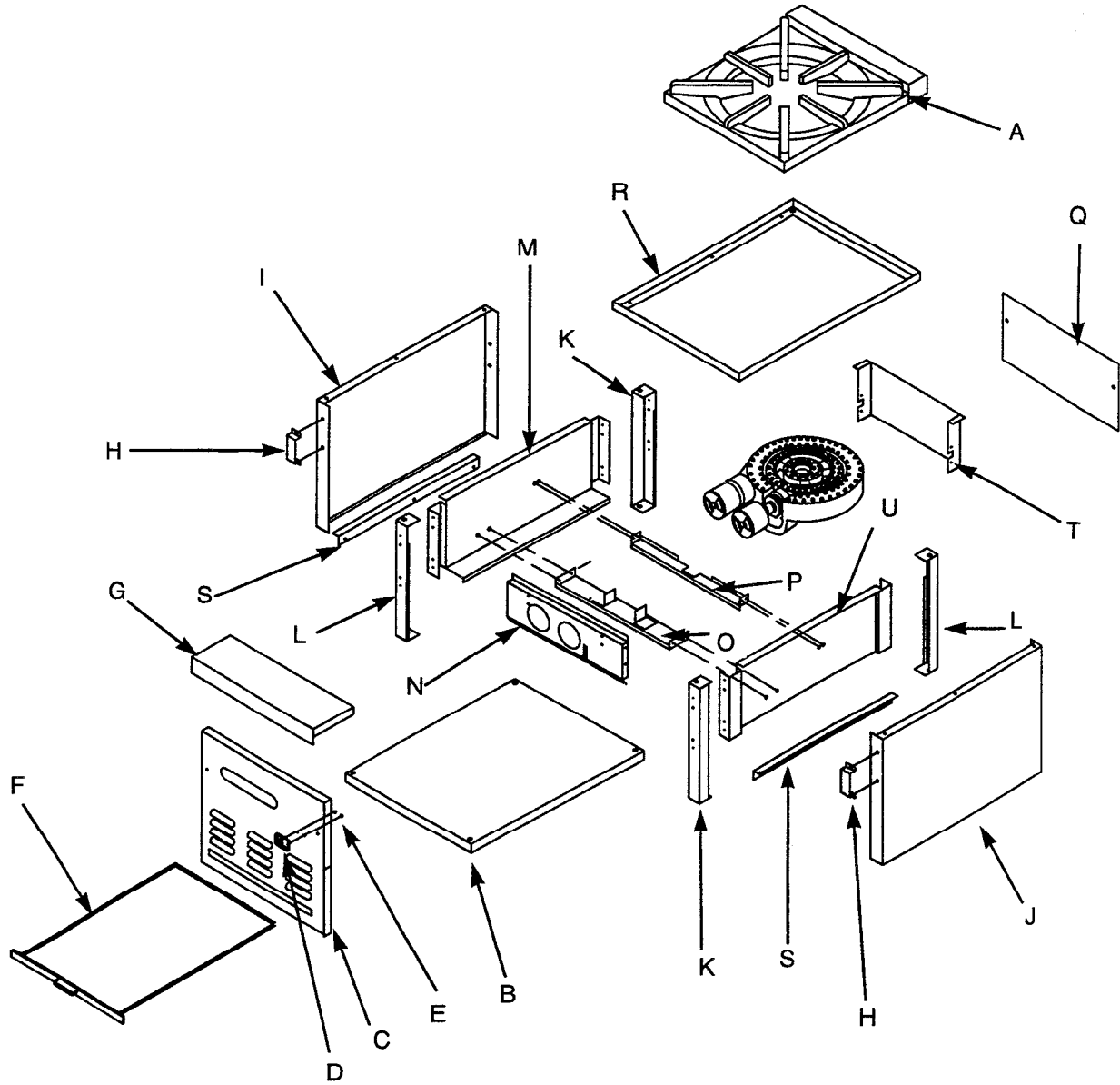

FIGURE 3

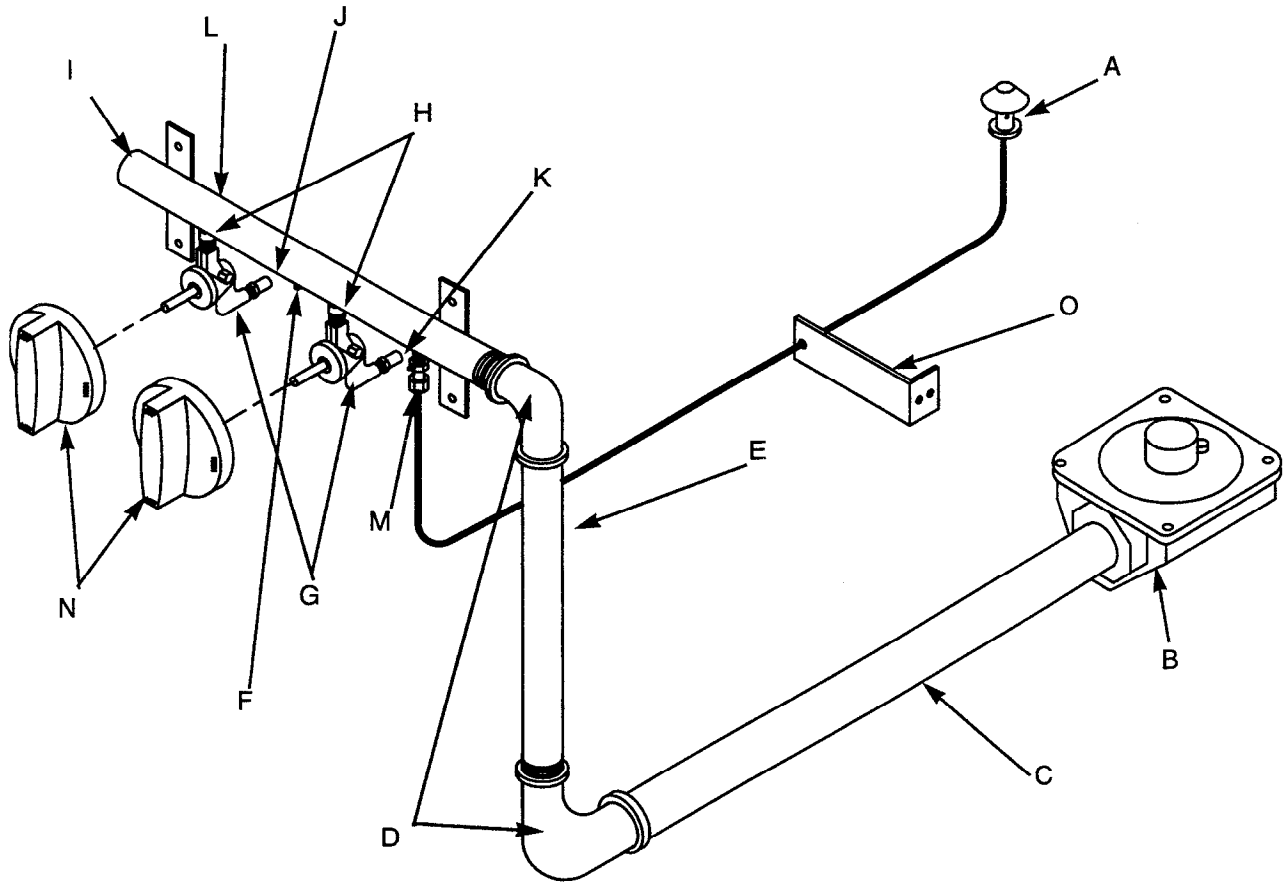

FIGURE 4

GAS LINE ASSEMBLY

ITEM	PART NUMBER	QUANTITY	DESCRIPTION
A	1179448	1	Pilot Assembly
B	1160205	1	Regulator (Natural)
	1160206	1	Regulator (Propane)
C	1179449	1	Gas Feed Pipe, 3/4", 24" Long
D	1146904	2	Elbow, 90° 3/4"
E	1179450	1	Gas Feed Pipe, 3/4", 7 3/8" Long
F	1147007	1	Plug, Pipe, Blk 1/8"
G	1021901	2	Valve
H	1179441	2	Adapter, Brass
I	1179517	1	Supply Manifold Assembly (Natural)
I	1179518	1	Supply Manifold Assembly (Propane)
J	1006442	1	Orifice Hood (Propane)
J	1006426	1	Orifice Hood (Natural)
K	1006446	1	Orifice Hood Propane)
K	1006429	1	Orifice Hood (Natural)
L	1179460	1	Manifold Pipe
M	1179451	1	Pilot Adjust
N	1160532	2	Knob
O	1179529	1	Pilot Bracket

* Includes all items in figure 4, except items A, B, N, O

PARTS

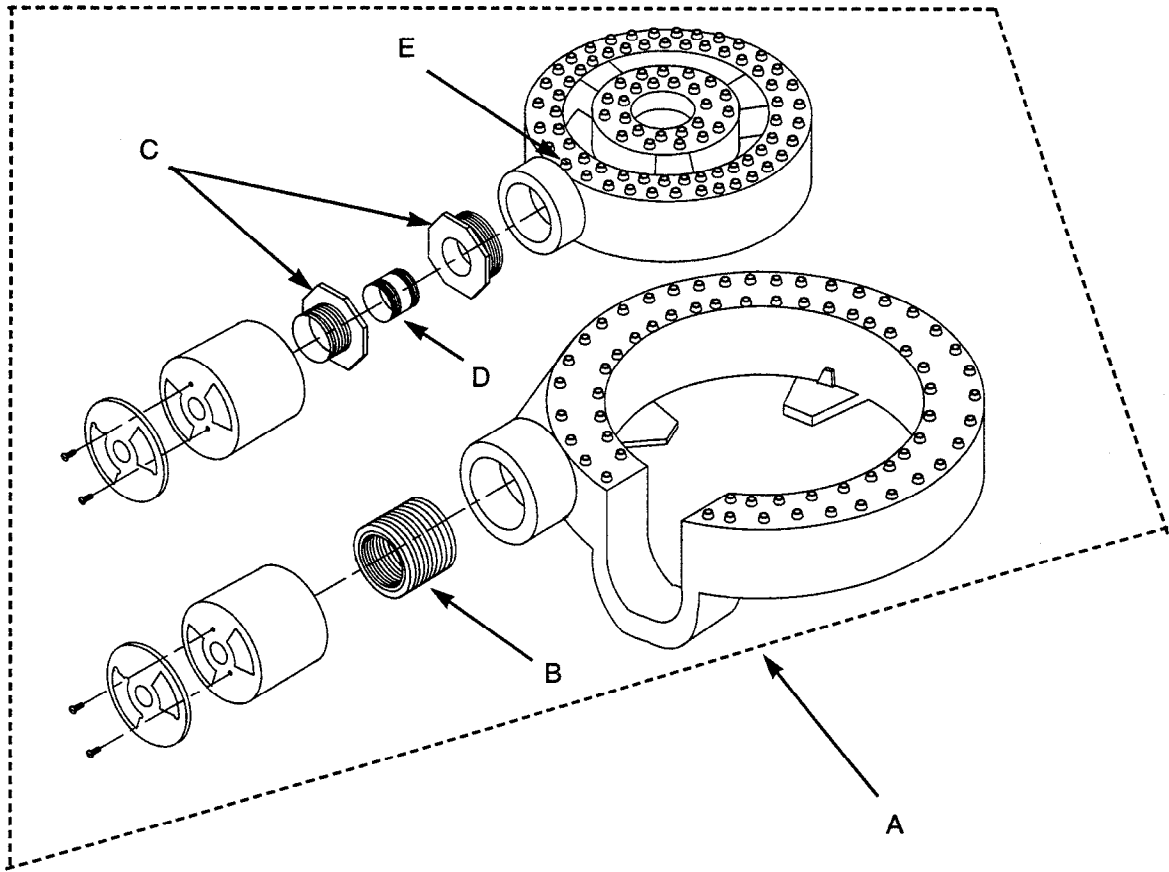

FIGURE 5

BURNER COMPONENTS

ITEM	PART NUMBER	QUANTITY	DESCRIPTION
A	1179470	1	Burner Assembly
B	1179462	1	Close Nipple Asm., 1 1/2" NPT
C	1179440	2	Bushing, Hex, 1 1/4" x 3/4"
D	1179439	1	Nipple, 3/4" x 2"
E	1179526	1	Screw, 10-24 x 2", Rd Hd, S.S.

OPTINAL ACCESORIES:

ITEM	PART NUMBER	DESCRIPTION
*	1179259	Wok Ring, Tall
*	1179387	Wok Ring, Short
*	1179388	Wok Pan, use with rings

* Not Shown

LIMITED WARRANTY

Southbend warrants that the equipment, as supplied by the factory to the original purchaser, is free from defects in materials and workmanship. Should any part thereof become defective as a result of normal use within the period and limits defined below, then at the option of Southbend, such parts will be repaired or replaced by Southbend or its Authorized Service Agency. This warranty is subject to the following conditions.

Repairs under this warranty are to be performed only by a Southbend Authorized Service Agency. Southbend cannot be responsible for charges incurred or service performed by non-Southbend Authorized Service Agencies. In all cases the closest Southbend Authorized Service Agency must be used.

TIME PERIOD:

One year labor, one year parts effective from the date of original purchase. The authorized service agency may at his option require proof of purchase.

Exceptions to standard warranty, effective within above limitations:

Glass Windows, Door Seals, Rubber Seals, Light Bulbs, Ceramic Bricks
Sight Glasses, Cathodic Descalers or Anodes, Broiler Briquettes and Drip Shields. . . . 90 days material and labor
Stainless Steel Fry Pot 4 years extended material warranty on fry pot only -- no labor
Stainless Steel Open Top Burners 4 years extended material warranty on burners only -- no labor
Pressure Steam Boiler Shell Prorated 4 years extended warranty on boiler shell only -- no labor
Boiler shells which have not been properly maintained will not be covered by warranty.

In all cases, parts covered by a five-year warranty will be shipped FOB Factory after the first year.

EXCLUSIONS:

The following conditions are not covered by warranty:

- Equipment failure relating to improper installation. Examples are: improper utility connection, improper utilities supply and problems due to ventilation.
- Equipment that has not been properly maintained. Examples are: calibration of controls, adjustments to pilots and burners, damage from improper cleaning, and water damage to controls.
- Equipment that has not been used in an appropriate manner, or has been subject to misuse or misapplication, neglect, abuse, accident, damage during transit or delivery, fire flood, riot or act of God.

If the equipment has been changed, altered, modified or repaired by other than a qualified service technician during or after the one-year limited warranty period, then the manufacturer shall not be liable for any damages to any person or to any property which may result from the use of the equipment thereafter.

Equipment failure caused by inadequate water quality is not covered under warranty. WATER QUALITY must not exceed the following limits: Total Dissolved Solids (TDS) - 60 PPM (Parts Per Million). Hardness - 2 Grains or 35 PPM, pH Factor - 7.0 to 7.5. Water pressure 30 PSI minimum, 60 PSI maximum. Boiler maintenance is the responsibility of the owner and is not covered by warranty.

This warranty does not cover services performed at overtime or premium labor rates nor does Southbend assume any liability for extended delays in replacing or repairing any items in the equipment beyond the control of Southbend, "Southbend shall not be liable for consequential or special damages of any nature that may arise in connection with such product or part." Should service be required at times which normally involve overtime or premium labor rates, the owner shall be charged for the difference between normal service rates and such premium rates.

This warranty only covers product shipped into the 48 contiguous United States and Hawaii. There will be no labor coverage for equipment located on any island not connected by roadway to the mainland.

This equipment is intended for commercial use only. Warranty is void if equipment is installed in other than commercial application.

Warranty on all replacement parts which are replaced in the field by Southbend Authorized Service Agencies will be limited to three months on labor, six months on materials (parts) effective from the date of installation. See LIMITED WARRANTY - REPLACEMENT PARTS for conditions and limitations.

"THE FOREGOING WARRANTY IS IN LIEU OF ANY AND ALL OTHER WARRANTIES EXPRESSED OR IMPLIED INCLUDING ANY IMPLIED WARRANTY OF MERCHANTABILITY OR FITNESS, AND CONSTITUTES THE ENTIRE LIABILITY OF SOUTHBEND. IN NO EVENT DOES THE LIMITED WARRANTY EXTEND BEYOND THE DURATION OF ONE YEAR FROM THE EFFECTIVE DATE OF SAID WARRANTY."

Consult the Southbend Authorized Parts/Service Distributor list for the Authorized Service Representative in your area. If this list is not available, call the Service Department at Southbend, 1-800-348-2558.

NO QUIBBLE WARRANTY

The foregoing warranty is exclusive and in lieu of all other warranties, expressed or implied. There are no implied warranties of merchantability or of fitness for a particular purpose.

- ☑ Southbend, hereinafter referred to as the seller, warrants equipment manufactured by it to be free from defects in material and workmanship for which it is responsible. The seller's obligation under this warranty shall be limited to replacing or repairing such part. Such warranty shall be limited to the original purchaser only and shall be effective for a period of one year from date of original installation or 18 months from date of purchase, whichever is earlier; provided that the terms of payment have been fully met.
- ☑ Normal maintenance functions, including lubrication, cleaning or customer abuse are not covered by this No Quibble Warranty.
- ☑ The seller shall be responsible only for repairs or replacements of defective parts performed by seller's authorized service personnel. Authorized service agencies are located in principle cities throughout the contiguous United States and Hawaii. This warranty is valid in the United States and is void elsewhere unless the product is purchased through Middleby International with warranty included.
- ☑ The foregoing shall be the seller's sole and exclusive obligation and the buyer's sole and exclusive remedy for any action including breach of contract or negligence. In no event shall the seller be liable for a sum in excess of the purchase price of the item. The seller shall not be liable for any prospective or lost profits of the buyer.
- ☑ This warranty is effective on Southbend equipment sold on, or after **Feb. 15, 1996**.



1100 Old Honeycutt Road
Fuquay-Varina, NC 27526

☎ (800) 348-2558

☎ (919) 552-9161

Fax (800) 625-6143

Fax (919) 552-9798

A product with the Southbend name incorporates the best in durability and low maintenance. We all recognize however, that replacement parts and occasional professional service may be necessary to extend the useful life of this unit. When service is needed, contact a Southbend Authorized Service Agency, or your dealer. To avoid confusion, always refer to the model number, serial number, and type of your unit.



SOUTHBEND
REGISTERED TO ISO 9001
CERTIFICATE NO. A2062



Certification No. FM25780



Southbend Registered to ISO 9001



First in Cooking. Built to Last.

A MIDDLEBY COMPANY

PART NUMBER 1177129

© 1995 SOUTHBEND PRINTED USA 10/95 REV 08/96

1100 Old Honeycutt Road
Fuquay-Varina, NC 27526

☎ (919) 552-9161

☎ (800) 348-2558

FAX (919) 625-6143

FAX (919) 552-9798