

1. External Parts

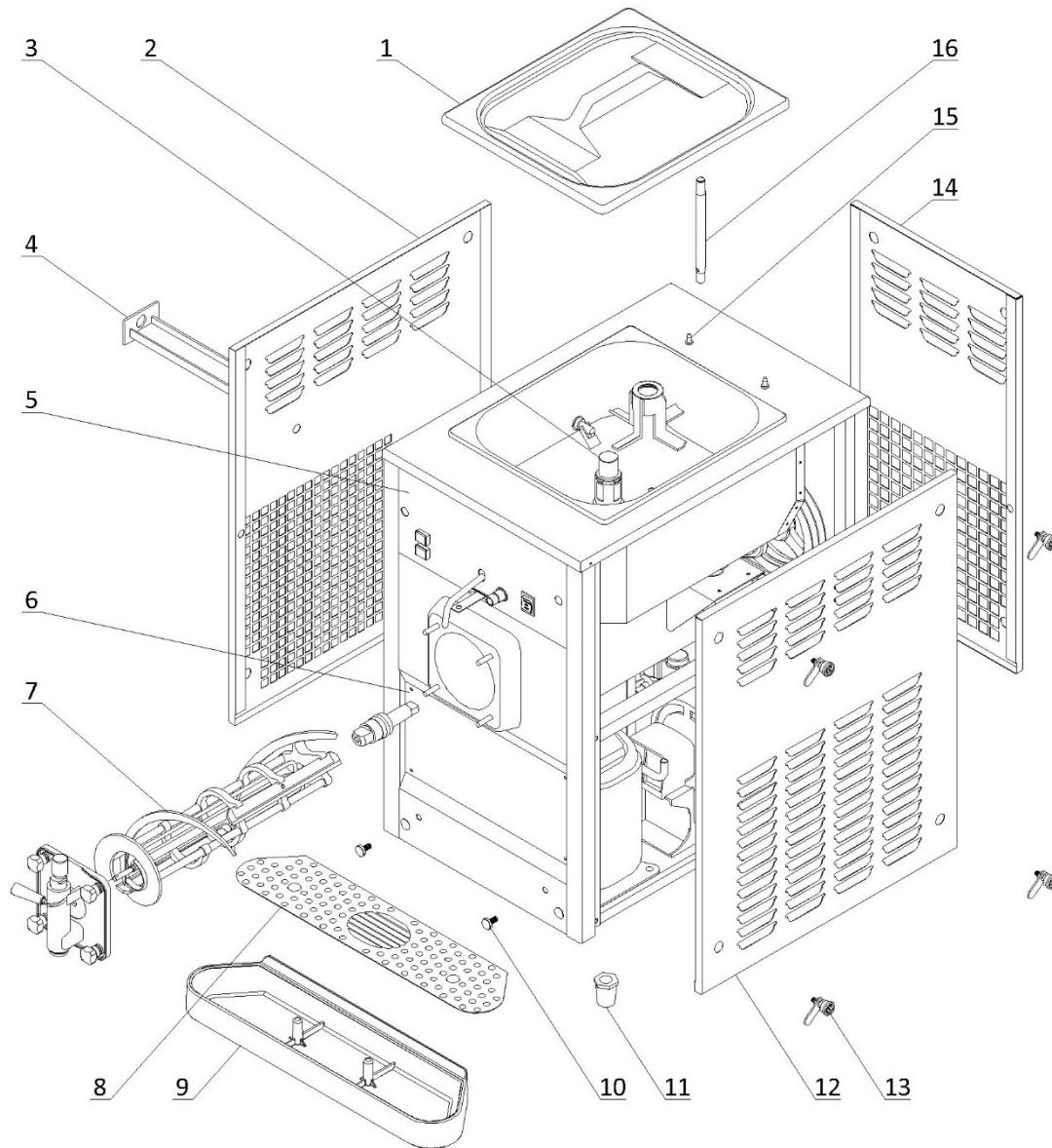

1. External Parts

Item	Part Number	Description	Qty.
1	3.4.03.02.001	Hopper Lid - 25L	1
2	2.3.4.18.005	Panel - Left - 6690	1
3	Page 7	Hopper Agitator	1
4	3.4.04.02.003	Internal Drip Tray - 25mm	1
5	Page 6	Draw Switch and Front Control Panel	1
6	2.3.4.17.005	Panel - Lower Front - 6690	1
7	Page 5	Dispensing Door and Beater	1
8	2.3.4.45.304	Splash Shield - Front Drip Tray - 58mm - White	1
9	3.4.04.01.010	Front Drip Tray - 58mm - White	1
10	3.6.39.004	Drip Tray Mounting Bolt	2
11	3.3.05.03.001	Leg - 45mm	4
12	2.3.4.20.004	Panel - Right - 6690	1
13	8.1.07.001	Panel Lock Assembly	12
14	2.3.4.13.006	Panel - Rear - 6690	1
15	3.6.39.011	Hopper Lid Holder	2
16	2.1.3.39.0006	Air Tube - FB	1

2. Internal Parts

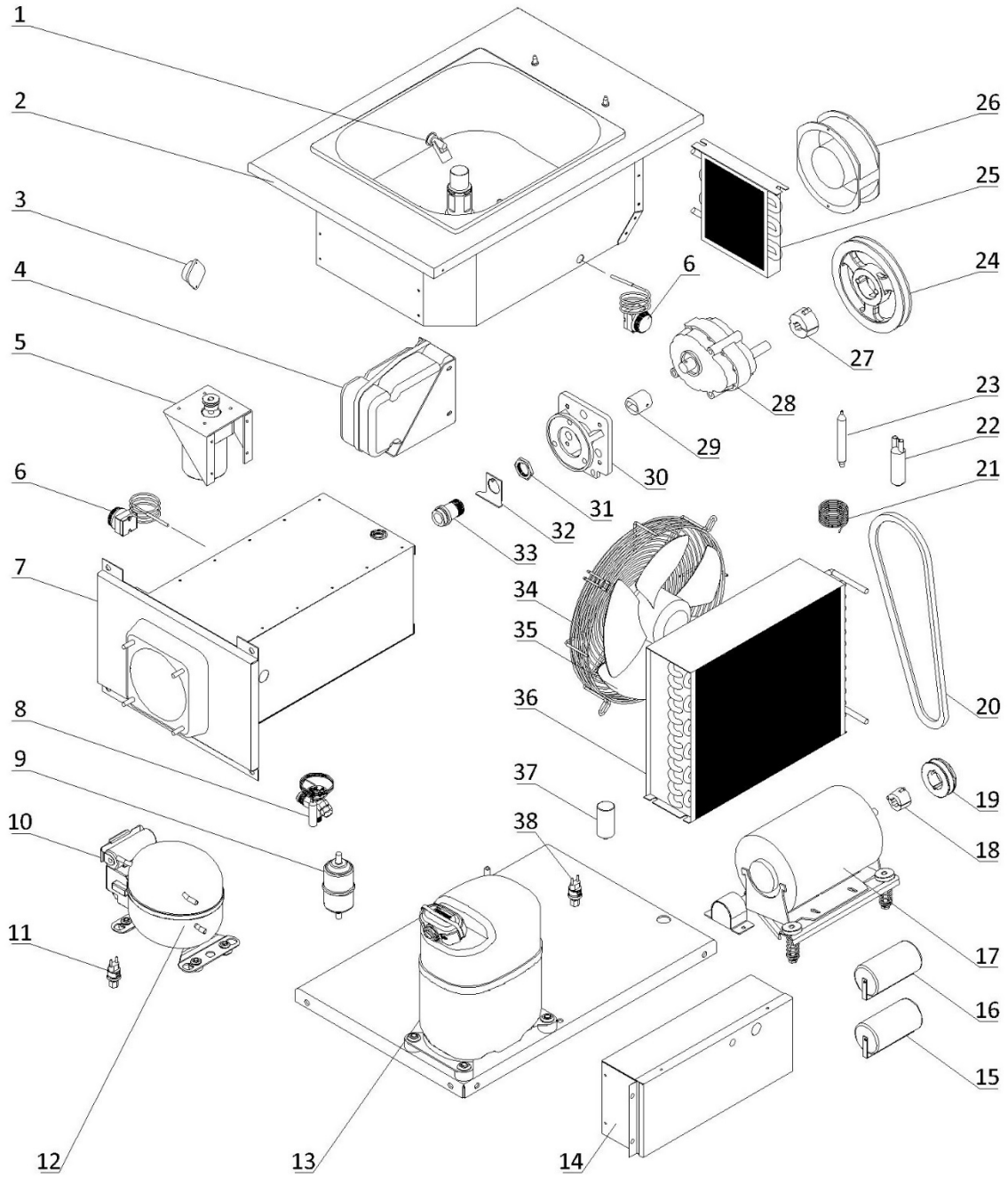

2. Internal Parts

Item	Part Number	Description	Qty.
1	920.1.04.0002	Mix Low Sensor Assembly	1
2	2.1.1.03.0012	Hopper Assembly - 6690	1
3	3.1.02.15.003	Alarm - Low Mix - DC3-24V	1
4	3.2.01.04.004	Start Component - Compressor - CAJ2464Z	1
5	Page 7	Agitator Motor Assembly	1
6	3.1.01.07.003	Thermostat - 0-40°C	2
7	2.1.1.06.0018	Cylinder Assembly - 6690	1
8	3.2.04.01.001	Thermal Expansion Valve - T2	1
9	3.2.04.05.002	Filter Drier - Cylinder - DML083S	1
10	3.2.01.01.002-1	Start Component - Compressor - EM30HHR	1
11	3.2.04.06.003	High Pressure Switch - 250~350psi	1
12	3.2.01.01.002.A	Auxiliary Compressor - EM30HHR	1
13	3.2.01.02.005.A	Primary Compressor - CAJ2464Z	1
14	Page 8	Electrical Box	1
15	3.1.02.22.062	Capacitor - Start - 330V - 160µF	1
16	3.1.02.22.009	Capacitor - Running - 370V - 25µF	1
17	3.3.01.07.010	Motor - 220/60/1 - 450W - K56AC66AF41	1
18	3.3.04.01.005	Bushing - 1008-16	1
19	3.3.04.02.012	Pulley - Beater Motor - SPA63-1-1008	1
20	3.3.03.01.002	Belt - Motor - Beater - V-XPA950	1
21	3.2.05.01.002	Capillary Tube - 2×0.7	1
22	3.2.04.07.001	Suction Accumulator - 25×100×0.6	1
23	3.2.04.05.001	Filter Drier - Hopper - 16×2.2×120	1
24	3.3.04.02.011	Pulley - Gear Box - SPA 168-1-1210	1
25	3.2.02.01.001	Auxiliary Condenser - Single - 0.7m ²	1
26	3.2.03.01.001	Fan Motor - BT220-15050S2HL	1
27	3.3.04.01.007	Bushing - 1210-16	1
28	3.3.02.01.024	Gear Box - FB - 45*20 Shaft - 79mm	1
29	3.3.02.04.006	Coupling Drive - 3.4qt-4.0qt-7.3qt - 20mm	1
30	2.1.3.15.0003	Bracket - Gear Box - 3.4-7.3qt - 79mm	1
31	3.3.02.02.010	Nut - Rear Shell Bearing	1
32	2.3.6.04.004	Lock Plate - Rear Shell Bearing - 42mm	1
33	3.3.02.02.002	Rear Shell Bearing - SS (3.4qt) + FB	1
34/35	3.2.03.04.002	Fan Motor - 220-60-1 - YWF4E-300S	1
36	3.2.02.01.006	Main Condenser - Single - 8m ² - 410x315x100	1
37	3.2.03.04.002-2	Capacitor - Fan Motor - 450V - 1.5µF - CBB60	1
38	3.2.04.06.004	High Pressure Switch - 350~500psi	1

3. Dispensing Door and Beater

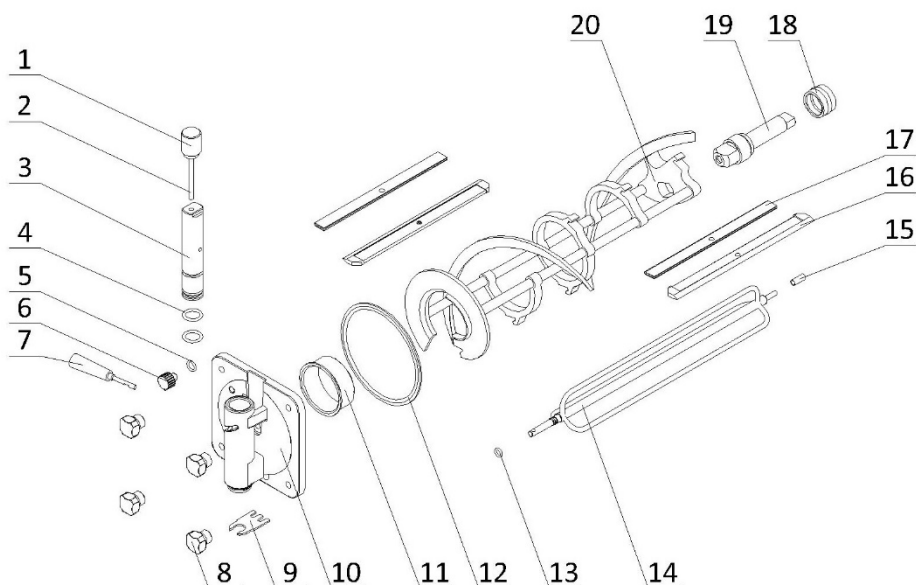

Item	Part Number	Description	Qty.
1	2.1.3.36.0004	Weight - Draw Valve - FB	1
2	2.1.3.36.0003	Pin - Draw Valve - FB	1
3	2.1.3.01.0006	Draw Valve - FB	1
4	3.4.08.01.036	O-Ring - 19x3.55	2
5	3.4.08.01.008	O-Ring - 11.5x2.5	1
6	3.4.07.08.001	Prime Plug - FB	1
7	3.4.05.01.002	Handle - Dispensing - FB	1
8	2.1.3.32.0004	Hand Screw - Dispensing - FB	4
9	2.1.4.04.014	Ice Buster - Dispensing - FB	1
10	2.1.3.14.0006	Dispensing Door - FB	1
11	3.4.01.03.003	Beater Guide - FB	1
12	3.4.08.02.005	Door Gasket - FB	1
13	3.4.08.01.017	O-Ring - 11x2.4	1
14	2.1.1.31.0001	Torque Rotor - 7.3qt	1
15	3.4.01.03.004	Torque Guide	1
16	3.4.02.01.003	Plastic - Scraper Blade - FB/6210	2
17	2.3.4.04.003	Clip - Scraper Blade - FB/6210	2
18	3.4.07.05.002	Gasket - Drive Shaft	1
19	2.1.3.25.0003	Drive Shaft - FB	1
20	2.1.1.10.0004	Beater - FB - Standard	1

4. Draw Switch and Front Control Panel

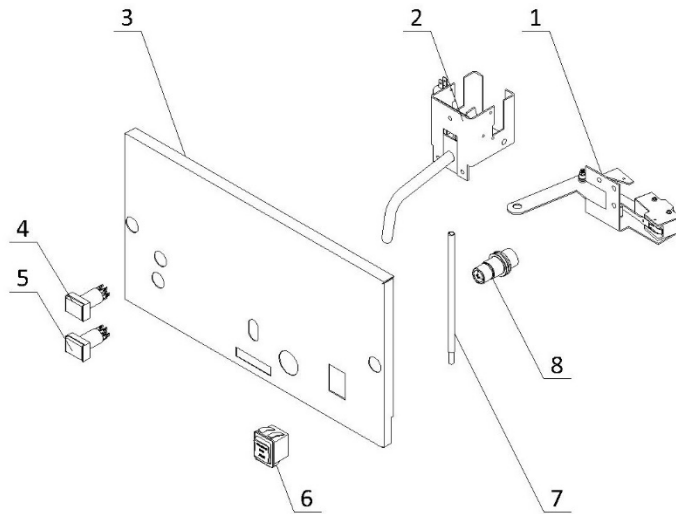

Item	Part Number	Description	Qty.
1	920.1.03.0002	Control Levers - Toque Lever	1
2	920.1.03.0003	Control Levers - Dispensing Switch	1
3	2.3.4.07.009	Panel - Draw Switch - 6690	1
4	3.1.02.14.001	Light - FB - Low Mix	1
5	3.1.03.04.015	Standby Switch - FB - Amber Light	1
6	3.1.03.03.002	Power Switch - KCD2-3	1
7	2.3.6.03.007	Torque Arm - 150mm - FB	1
8	920.1.03.0001	Control Levers - Viscosity Adjustment	1

5. Hopper Agitator

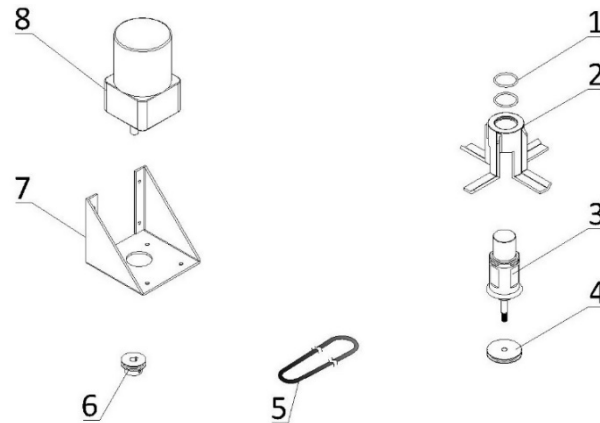

Item	Part Number	Description	Qty.
1	3.4.08.01.034	O-Ring - 31×2	2
2	2.1.1.23.0002	Blade - Hopper Agitator - Standard - V2	1
3	2.1.1.12.0003	Agitator Assembly - 124mm	1
4	2.1.4.02.017	Pulley - Hopper Agitator - Single - 47.6mm	1
5	2.1.4.08.045	Belt - Hopper Agitator - 415mm	1
6	3.3.04.04.006	Pulley - Hopper Agitator - Drive - 30mm	1
7	2.3.4.45.003	Bracket - Agitator Motor - 84mm	1
8	3.3.01.01.006	Motor - Agitator - 220V - YN80-25-6G	1

6. Electrical Box

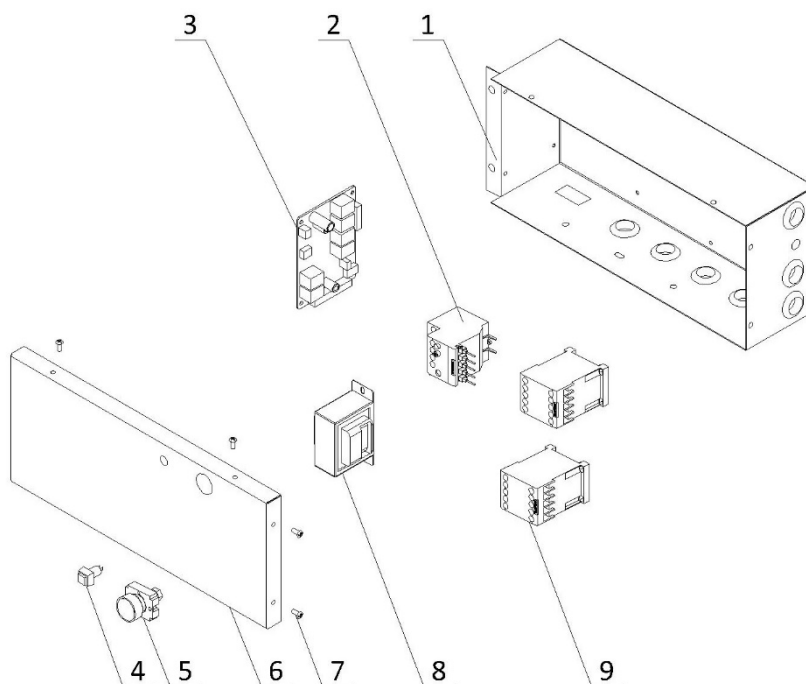

Ite	Part Number	Description	Qty.
1	2.2.4.17.0006	Electrical Box - 6690/6690-C	1
2	3.1.01.02.010	Thermal Overload Relay - 3RU6116-1E00	1
3	2.1.1.30.0012	Control Board - FB	1
4	3.1.03.04.003	Switch - FB - Low Mix Alarm - Green Square	1
5	3.1.03.04.002	Reset Button - Thermal Overload	1
6	2.2.4.20.0006	Cover - Electrical Box - 6690/6690-C	1
7	3.6.19.001	Screw - M4x8	4
8	3.1.01.04.007	Transformer - 50W - 50313MW232	1
9	3.1.01.01.010	Contactors - 220V - 3RT6017-1AN21	2