

IMPORTANT FOR FUTURE REFERENCE

Please complete this information and retain this manual for the life of the equipment:

Model #: _____

Serial #: _____

Date Purchased: _____



OPERATIONS and PARTS MANUAL

SBF14 & SBF18

Southbend

Filter System



Southbend  A Middleby Corporation Company
1100 Old Honeycutt Road, Fuquay-Varina, NC 27526
(919) 762-1000 phone (919) 552-9798 fax

TO THE PURCHASER, OWNER AND STORE MANAGER

Please review these warnings prior to posting them in a prominent location for reference.

WARNING

DO NOT store or use gasoline or other flammable vapors and liquids in the vicinity of this or any other appliance.

WARNING

Improper installation, alteration, service or maintenance can cause property damage, injury or death. Read the installation, operating and maintenance instructions thoroughly before installing or servicing this appliance.

WARNING

Installation, maintenance and repairs should be performed by a Pitco Authorized Service and Parts (ASAP) company technician or other qualified personnel. Installation, maintenance or repairs by unauthorized and unqualified personnel will void the warranty.

WARNING

Installation and all connections must be made according to national and local regulations and codes in force.

WARNING

A country approved all pole circuit breaker with a minimum open contact gap of 3mm must be used for proper installation. (CE countries)

WARNING

During the warranty period if a customer elects to use a non-original part or modifies an original part purchased from Pitco and/or its Authorized Service and Parts (ASAP) companies, this warranty will be void. In addition, Pitco and its affiliates will not be liable for any claims, damages or expenses incurred by the customer which arises directly or indirectly, in whole or in part, due to the installation of any modified part and/or received from an unauthorized service center.

WARNING

This appliance, when installed, must be electrically grounded in accordance with local codes, or in the absence of local codes, with the National Electrical Code, ANSI/NFPA 70, or the Canadian Electrical Code, CSA C22.2, as applicable.

WARNING

DO NOT alter or remove structural material on the appliance to facilitate storage or for any other reason.

WARNING

This appliance is intended for professional use only and should be operated by fully trained and qualified personnel.

WARNING

DO NOT use the electrical cord as a leash to move the appliance. Series injury and appliance damage can occur.

WARNING

If the supplied power cord or receptacle is damaged, it must be replaced by a Pitco Authorized Service and Parts (ASAP) company technician, or a similarly qualified person in order to avoid a hazard.

WARNING

The power supply must be disconnected before servicing, maintaining or cleaning this appliance.

WARNING

The appliance is NOT jet stream approved. DO NOT clean the appliance with a water jet.

WARNING

DO NOT attempt to move this appliance or transfer hot liquids from one container to another when the unit is at operating temperature or filled with hot liquids. Serious personal injury could result if skin comes in contact with the hot surfaces or liquids.

WARNING

DO NOT sit or stand on this appliance. The appliance's top panel, filter pan, filter carriage, pan cover is not a step. Serious injury could result from slipping, falling or contact with hot liquids.

WARNING

NEVER use the appliance as a step for cleaning or accessing the ventilation hood. Serious injury could result from slips, trips or from contacting hot liquids.

WARNING

The filter pan should be dry and free of water droplets prior to use. Serious injury could result from hot steam vapors when hot oil/shortening mixes with water.

WARNING

DO NOT overfill filter pan with hot oil/shortening. Do not leave appliance unattended while draining or refilling with oil/shortening. Over filling the appliance can cause serious injuries and damage the appliance.

WARNING

The contents of the crumb catch and/or filter pan of any filter system must be emptied into a fireproof container at the end of each day. Some food particles can spontaneously combust if left soaking in certain types of oil or shortening.

WARNING

Completely shut the appliance down when the oil/shortening is being drained from the appliance. This will prevent the appliance from heating up during the draining and filling process. Serious injury and appliance damage can occur.

WARNING

This appliance is intended for indoor use only.

WARNING

DO NOT operate appliance unless all panels and access covers are attached correctly.

WARNING

It is recommended that this appliance be inspected by a qualified service technician for proper performance and operation on a yearly basis

WARNING

This appliance is designed to operate on a specific voltage. This information can be found on the data plate located on the rear of the appliance

FILTERING INSTRUCTIONS- MOBILE UNITS

WARNING:

At operating temperature, the shortening in the fryer may be hotter than 375°F (190°C). This hot, melted shortening can cause you to be burned very badly. Do not let the hot shortening touch your skin or clothing. Always wear insulated protective clothing, this should include, but is not limited to, insulated oil-proof rubber gloves, eye protection or face mask and long sleeves when filtering.

**Filter the fryer twice daily for best results.
Filter while the oil is hot.**

1. Turn the fryer off before you drain and filter the oil.
2. Pull the filter pan out on the carriage slide. Prepare the filter pans as follows:
 - Place the paper support rack (item 14) in the bottom of the pan.
 - Place the paper (item 12) on top of the support rack. Use a new piece of paper if the old paper is dark, scuffed, or torn.
 - Place the paper retainer rack (item 15) in the pan. Place the rack so the support rod for the flush nozzle sits in the front right corner of the pan. Snap the handles of the paper retainer rack in place under the clips on the pan.
 - Place the pan cover (item 16) over the pan.
 - Insert the crumb basket (item 17) into the opening in the cover.
3. Securely connect the filter pan hose (item 11) to the inlet fitting on the filter. Use the quick-disconnect. Install the extension (item 4) on the fryer's drain nipple.
4. Connect the flush hose to the outlet fitting. Use the quick-disconnect. Place the end of the hose nozzle over the holding rod in the filter pan.
5. Now you are ready to begin filtering. Position the filter pan under the drain extension with the crumb basket directly below the drain outlet. Open the fryer's drain valve (blue handle). Drain the oil into the filter pan.
6. Hold the nozzle in the bottom of the fryer. Turn the filter switch on. Wash all of the debris from the sides of the fryer and down the drain. When the tank is clean, turn the filter switch off and close the fryer's drain valve (blue handle). Return the nozzle to holding rod on the filter pan.
7. With the nozzle on the holding rod, circulate the oil through the filter. Turn the filter switch on for about two minutes to circulate the oil.
8. Return the oil to the fryer. Turn the filter switch off, place the nozzle in the tank, and turn the filter switch on again. The pump will return the filtered oil to the tank. After all the oil has been returned to the fryer, turn the filter switch off. Return the nozzle to the holding rod in the filter pan. The fryer is ready to be put back into service.
9. If you are going to filter another fryer at this time, empty the crumb basket, and scrape up the debris from the filter paper. For each fryer, repeat steps 5, 6, 7 and 8. Change the filter paper when it becomes dark, scuffed, or torn.
10. When you are finished filtering, remove the flush hose. Disconnect the flush hose from the outlet fitting and drain the hose into the filter pan. Empty the crumb basket; scrape the debris off of the filter paper and into a fireproof container. Please allow the crumbs to cool to room temperature before disposing.
11. Remove the pan cover, filter paper retainer rack, the used filter paper, and the filter paper support rack. The filter pan can then be removed for cleaning. Clean pump and dolly assembly by wiping down the unit with a damp cloth.

► CAUTION

DO NOT PUMP WATER THROUGH THE FILTER PUMP SYSTEM. THE PUMP FUNCTIONS USING THE LUBRICATION OF THE OIL AND USING WATER WILL CAUSE DAMAGE TO THE PUMP.

► WARNING

DO NOT ATTEMPT TO LIFT FILTER MACHINE OFF FLOOR FOR CLEANING. BODILY INJURY MAY OCCUR.

(In the event water gets into the piping of the filter pan, it must be drained out. With the unit broken down for cleaning, tip pan towards intake piping and gently raise hose so fluid drains into pan, and then remove fluid from pan.)

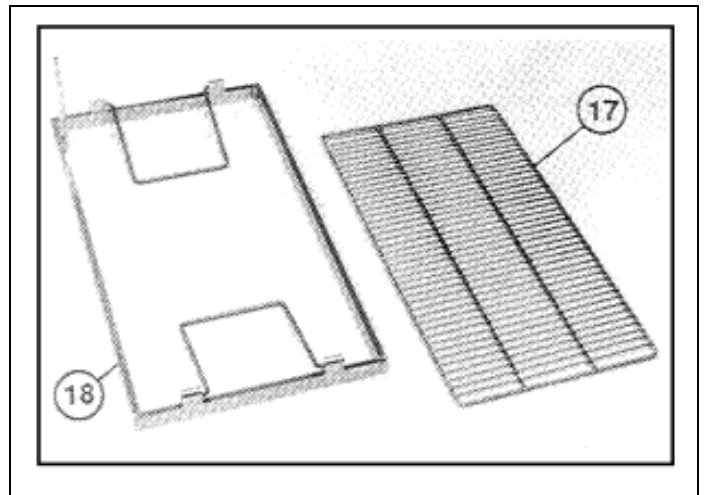
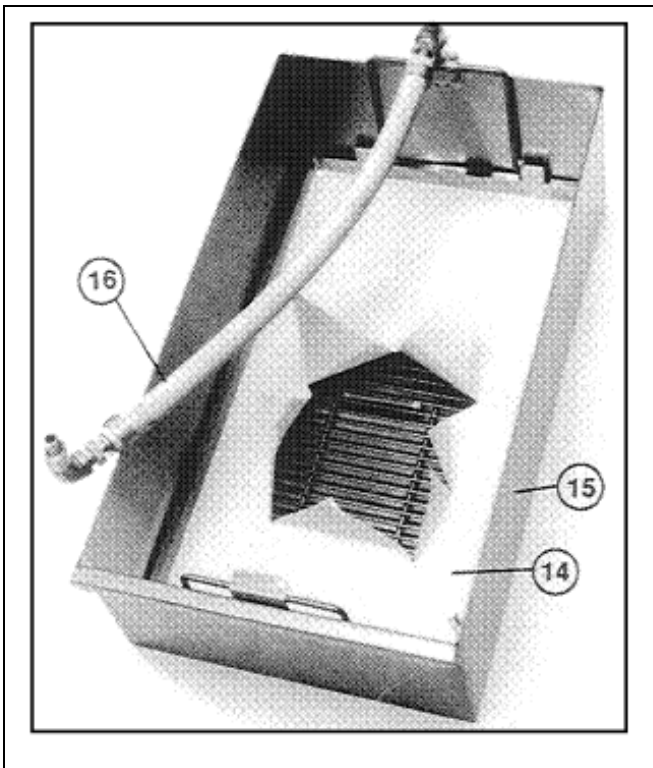
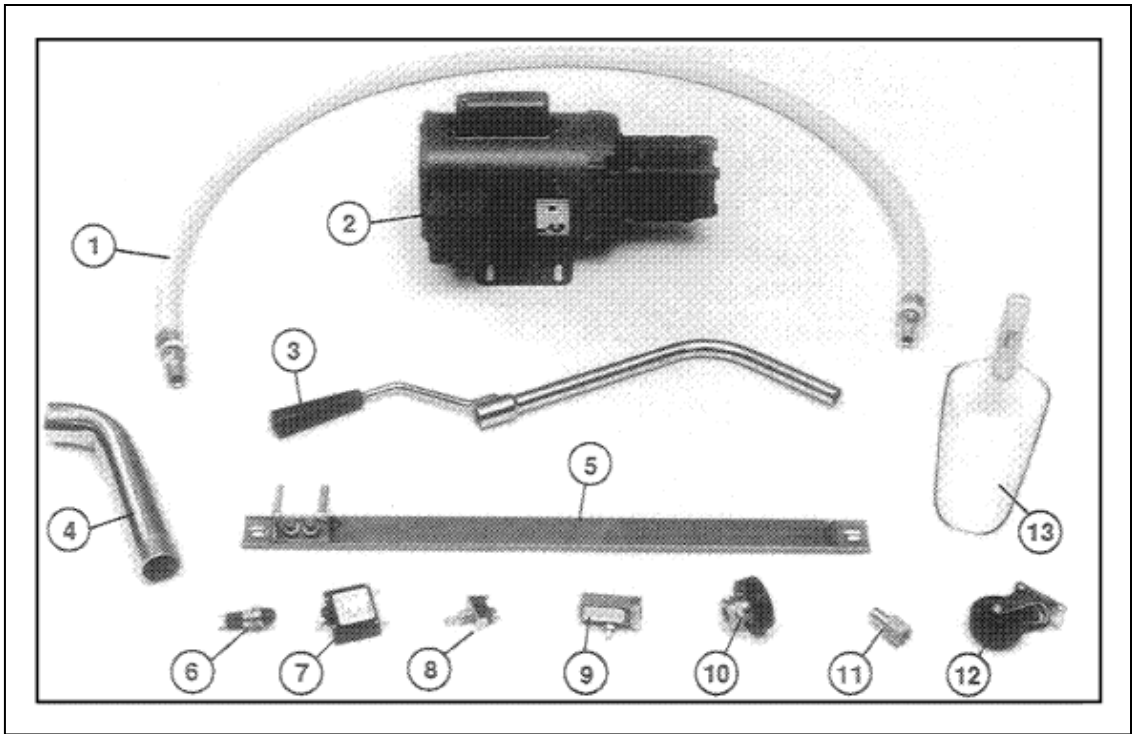

PARTS LIST

| Item # | Part Description | SouthBend Model | Part Number |
|--------|---------------------------------------|----------------------|--------------------------|
| 1 | Flush Hose w/threaded end fitting | All | B7406407 |
| 2 | Pump and motor assembly | All | P5046381 |
| 3 | Nozzle w/Handle bracket only | All | B7406301 |
| | Handle only, black, for nozzle | All | P6071190 |
| 4 | Drain Nipple Extension 1 ¼" | All | A2510101 |
| 5 | Heaters, 115V AC, two needed | All | P5046980 |
| 6 | Light base | All | P5045010 |
| | Light bulb | All | P5045030 |
| | Light lens, red | All | P5046326 |
| 7 | Circuit Breaker | All | P5045217 |
| 8 | Pump Switch | All units w/o heater | P5047162 |
| | Pump and heater switch | All units w/heater | P5047163 |
| 9 | Pressure hose valve | All | P6071480 |
| 10 | Quick Disconnect, Female – Black Ring | All | B7402241 |
| | Quick Disconnect, Female – White Ring | All | B7402240 |
| 11 | Quick Disconnect, Male | All | P6071123 |
| 12 | Caster, non-locking | All - Rear | P6071062 |
| | Caster, locking | All- Front | PP11381 |
| 13 | Cleaning scoop | All | P6071369 |
| 14 | Filter Paper, 13 ½" X 24" HD | SBF14 | P6071371 |
| | Filter Paper, 13 ½" X 24" HD | SBF18 | P6071373 |
| 15 | Filter Pan | SBF14 | B7403601 |
| | | SBF18 | B7403701 |
| 16 | Hose, Inlet 10" | All | B7406404 |
| 17 | Filter Paper Support Rack | SBF14 | P6072611 |
| | | SBF18 | P6072612 |
| 18 | Filter Paper Retainer Rack | SBF14 | B6603001 |
| | | SBF18 | B6603002 |
| | NOT SHOWN: | | |
| | Measuring cup | All | P6071368 |
| | Precoat or Diatomaceous earth, 50 lbs | All | P6071368 |

TROUBLESHOOTING

| Symptom | Possible Cause/ | Corrective Action |
|--|--|--|
| Pump doesn't start when filter is turned on. | <ul style="list-style-type: none"> • Power cord isn't plugged into wall. • Power cord is loose at filter receptacle. • Circuit breaker has tripped. • Pump motor thermal overload has tripped. | <ul style="list-style-type: none"> • Plug in power cord. • Plug power cord into receptacle at rear of filter. • Turn power switch "OFF". Reset Circuit Breaker. • Turn power switch "OFF". Allow filter motor to cool. Remove cap covering reset hole in housing. Press red reset button on motor end. |
| Pump stops during filtering. | <ul style="list-style-type: none"> • Circuit breaker has tripped. • Pump motor thermal overload has tripped. • Pump is blocked or wiring is loose. | <ul style="list-style-type: none"> • Turn power switch "OFF". Reset Circuit Breaker. • Turn power switch "OFF". Allow filter motor to cool. Remove cap covering reset hole in housing. Press red reset button on motor end. • Contact a qualified service technician. |
| Filter pumps slowly or not at all. | <ul style="list-style-type: none"> • Filter media is clogged • Filter flush hose is clogged • Inlet hose is clogged | <ul style="list-style-type: none"> • Turn power switch "OFF". Allow filter to cool. Empty pan and change or clean filter media. • Turn power switch "OFF". Remove hose and clean. • Allow filter to cool. Empty pan and clear inlet hose. |
| Pumping is erratic | <ul style="list-style-type: none"> • Filter media improperly installed • Loose hose connections. | <ul style="list-style-type: none"> • Allow filter to cool. Empty pan. Verify filter media, support rack, and hold down are installed properly. • Verify that inlet and flush hoses are connected properly. |
| Excessive air bubbles in oil being pumped. | Air leak on inlet side of pump. | Check inlet hose for proper connection. |

SCHEMATICS

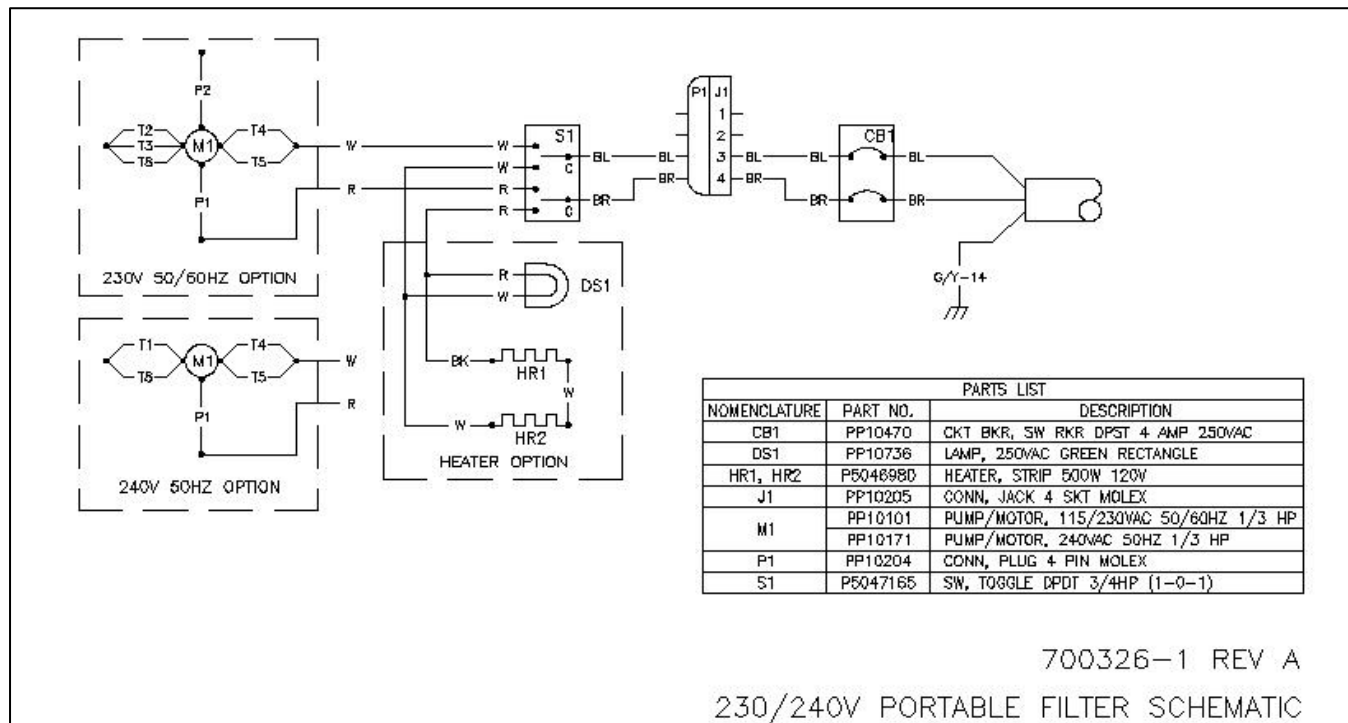
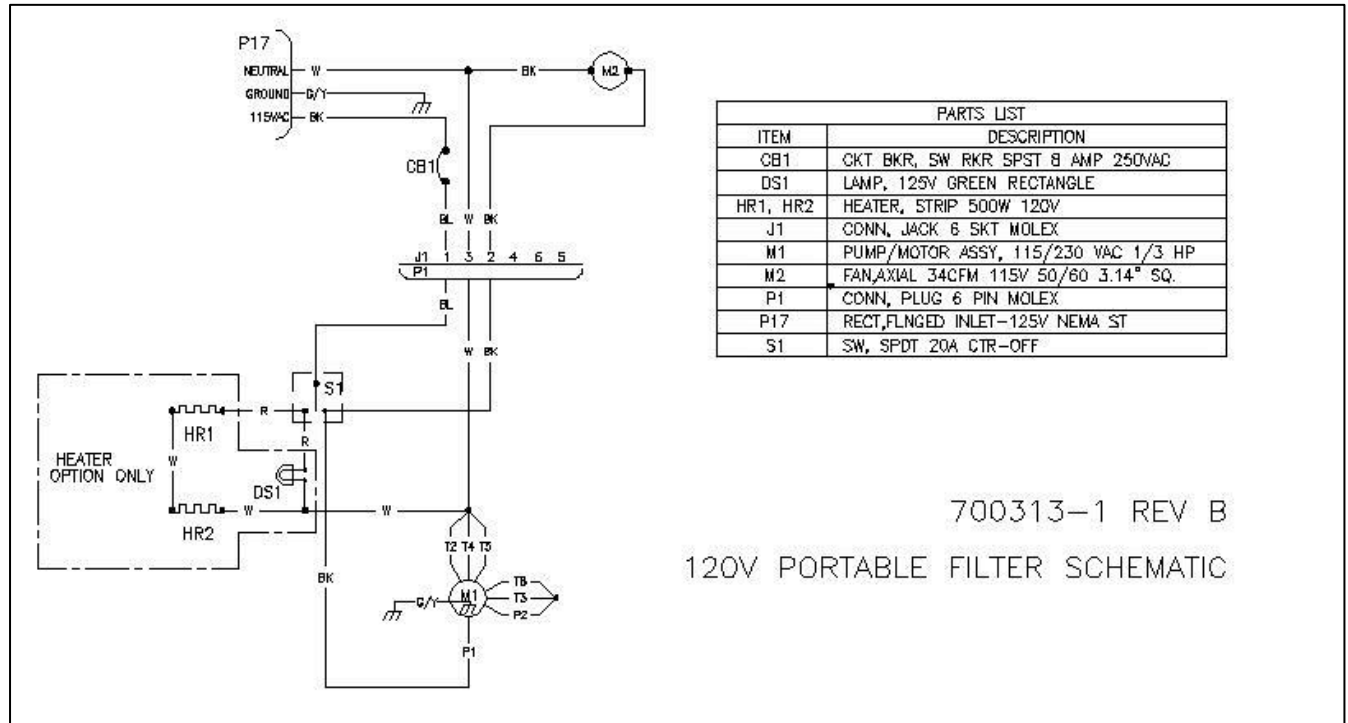

In the event of problems with or questions about your order, please contact the
Southbend at:(919) 762-1000 World Wide
Website Address: www.southbend.com

Southbend  **[A Middleby Corporation Company](#)**
1100 Old Honeycutt Road, Fuquay-Varina, NC 27526
(919) 762-1000 phone (919) 552-9798 fax