



Installation & Operations Manual

Including Parts Lists

IMPORTANT FOR FUTURE REFERENCE
Please complete this information and retain this manual for the life of the equipment:
Model #: _____
Serial #: _____
Date Purchased: _____

Fryer

Model P16-PF45, P20-PF65



THIS MANUAL MUST BE RETAINED FOR FUTURE REFERENCE

FOR YOUR SAFETY

DO NOT store or use gasoline or other flammable vapors or liquids in the vicinity of this or any other appliance.

WARNING

Improper installation, alteration, service or maintenance can cause property damage, injury or death. Read the installation, operating and maintenance instructions thoroughly before installing or servicing this equipment.

TO THE PURCHASER

Post in a prominent location the instructions to be followed in the event that an operator smells gas. Obtain this information from your local gas supplier.

WARNING

There is an open flame inside the fryer. The unit may get hot enough to set near by materials on fire. Keep the area around the fryer free from combustibles.

WARNING

DO NOT supply the fryer with a gas that is not indicated on the data plate. If you need to convert the fryer to another type of fuel, contact your dealer.

WARNING

DO NOT use an open flame to check for gas leaks!

WARNING

Wait 5 minutes before attempting to relight the pilot to allow for any gas in the fryer to dissipate.

WARNING

Never melt blocks of shortening on top of the burner tubes. This will cause a fire, and void your warranty.

WARNING

Water and shortening **DO NOT** mix. Keep liquids away from hot shortening. Dropping frozen liquid food into the hot shortening will cause violent boiling.

WARNING

Ensure that the fryer can get enough air to keep the flame burning correctly. If the flame is starved for air, it can give off a dangerous carbon Monoxide gas. Carbon monoxide is a clear odorless gas that can cause suffocation.

WARNING

A cooker equipped with casters and a flexible gas line, must be connected to the gas supply with a quick disconnect device. This quick disconnect must comply with ANSI Z24.41. To limit the movement of the cooker without depending on the connector or quick disconnect, a restraining cable must also be installed.

NOTICE

Counter top must be constructed of a non-combustible material for counter top fryer installations.

CHECKING YOUR NEW FRYER

Your new fryer has been carefully packed into one crate. Every effort has been made to ensure that your fryer is delivered to you in perfect condition. As you unpack your new fryer, inspect each of the pieces for damage. If something is damaged, DO NOT sign the bill of lading. Contact the shipper immediately, the shipper is only responsible for 15 days after delivery. Check the packing list enclosed with your fryer to ensure that you have received all of the parts to the fryer. If you are missing any parts, contact the dealer from whom the fryer was purchased.

CAUTION

To prevent equipment damage, don't tilt the fryer onto any two of its casters or pull the unit by the flue vents.

Leg/Caster Installation and Adjustment

Installing the legs and leveling the fryer is done with a 7/16" wrench, socket, and a large pair of water pump pliers. The legs/casters must be installed to provide the necessary height to meet sanitation requirements and assure adequate air supply to the burner. Attach the legs by performing the following procedure.

- a. Lay the fryer on its side being careful not to damage the flue by pulling on it. Protect the outside of the fryer with cardboard or a drop cloth when laying it down.
- b. Attach each leg/caster with the hex head cap screws supplied with the fryer. Each leg/caster requires four 1/4-20 x 5/8" cap screws.
- c. Mount the screws from the inside of the fryer with the nut on the outside. The nuts have lock washers attached to them, therefore it is not necessary to use lock washers.
- d. When all four legs/casters are mounted, stand the unit up being careful not to put too much weight on any one leg/caster. Adjust the height and level the fryer by adjusting the leveling devices on the leg/caster with the water pump pliers.
- e. On units with casters, move the fryer to the desired location and lock the wheels using the locking devices on the front of the casters.

WARNING

**The fryer must be properly restrained to prevent movement or tipping. This restraint must prevent the fryer from movements that would splash hot liquids on personnel, which could cause severe burns or injuries.
Always wear oil proof gloves when moving or handling equipment or hot liquids.**

Installation Clearances

The fryer needs clearance around it for proper operation. Adequate clearances allow for servicing and proper burner operation. The clearances shown below are for cooker installation in combustible and noncombustible construction.

	Combustible Construction	Non-Combustible Construction	
Back	6"	0"	
Sides	6"	0"	
Floor - Combustible	9"	9"	(Needed for Combustion)

Gas Connection

Your fryer will give you peak performance when the gas supply line is of sufficient size to provide the correct gas flow. The gas line must be installed to meet the local building codes or National Fuel Gas Code ANSI Z223.1 Latest Edition. In Canada, install the fryer in accordance with CAN/CGA-B149.1 or .2 and local codes. Gas line sizing requirements can be determined by your local gas company by referring to National Fuel Gas Code, Appendix C, Table C-4 (natural gas) and Table C-16 (propane). The gas line needs to be large enough to supply the necessary amount of fuel to all appliances without losing pressure to any appliance.

WARNING

NEVER supply the fryer with a gas that is not indicated on the data plate. Using the incorrect gas type will cause improper operation. If you need to convert the fryer to another type of fuel, contact your dealer.

Fuel Types - Each fryer is equipped to work with one type of fuel. The type of fuel with which the appliance is intended to operate is stamped on the data plate attached to the inside of the door.

NOTICE

NEVER use an adaptor to make a smaller gas supply line fit the cooker connection. This may not allow proper gas flow for optimum burner operation, resulting in poor cooker performance.

Quick Disconnect Gas Connection

Gas fryers equipped with casters must be installed with connectors that comply with the Standard for Connectors for Movable Gas Appliances, ANSI Z223.1 Latest Edition, and Addenda Z21.69A Latest Edition. This connection should include a quick disconnect device that complies with the Standard for Quick Disconnect Devices for Use With Gas Fuel, ANSI Z223.1 Latest Edition. When installing a quick disconnect you must also install a means for limiting the movement of the fryer. This device will prevent the gas line or the quick disconnect from being strained. The restraining device should be attached to the cooker on the back panel.

Fuel Supply Line Leak and Pressure Testing

The fuel supply system must be tested before the fryer is used. If the fuel line is going to be tested at a pressure greater than (>)1/2 PSIG (3.45 kPa), make sure that the fryer is disconnected from the fuel line. If the fuel line is to be tested at a pressure equal to or less than (<) 1/2 PSIG (3.45 kPa), the fryer can be connected but the unit's gas valve must be shut. Test all gas line connections for leaks with a solution of soap and water when pressure is applied.

ELECTRICAL CONNECTION

The electrical service used by the fryer must comply with local codes. If there are no local codes that apply, refer to the National Electrical Code (NEC), ANSI/NFPA 70 to install the service. In Canada refer to CSA Standard C22.1 and local codes. Wiring diagrams are provided inside the fryer control box.

Ventilation and Fire Safety Systems

Your new fryer must have proper ventilation to function safely and properly. Exhaust gas temperatures can reach as high as 1000°F. Therefore, it is very important to install a fire safety system. Your ventilation system should be designed to allow for easy cleaning. Frequent cleaning of the ventilation system and the fryer will reduce the chances of fire. Table 1-2 provides a list of reference documents that provide guidance on ventilation and fire safety systems. This table is not necessarily complete. Additional information can be obtained from the CSA-International, 8501 East Pleasant Valley Road, Cleveland, OH 44131.

Excessive ventilation causes drafts, which will interfere with the proper operation of the pilot and the burner. Leave at least 18 inches of open space between the fryer's flue vent opening and the intake of the exhaust hood.

CAUTION

Ensure that your ventilation system does not cause a down draft at the fryer's flue opening. Down drafts will not allow the fryer to exhaust properly and will cause overheating which may cause permanent damage. Damage caused by down drafts will not be covered under equipment warranty. NEVER allow anything to obstruct the flow of combustibles or ventilation exiting from the fryer flue. DO NOT put anything on top of the flue area.

NOTICE

NEVER connect the blower directly to the flue openings. The direct flow of air will cause poor temperature recovery, poor ignition, inefficient operation of the fryer, and could extinguish the pilot.

Gas Line Requirements

A properly installed gas supply system will deliver 7.0 ± 2.0 " w.c. natural gas (12.0 ± 2.0 " w.c. LP) to all appliances connected to the line, operating at full demand.

NOTICE

Do NOT exceed 13.5" W.C. pressure as damage may occur to the gas valve.

LIGHTING INSTRUCTIONS

- a. Fill kettle before lighting.
- b. Turn combination gas valve knob to “PILOT” position.
- c. Depress valve knob and light pilot. With pilot burning, hold knob depressed for 60 seconds.
- d. Release knob, pilot should remain lit.
- e. **DO NOT TURN COMBINATION GAS VALVE KNOB TO THE “ON” POSITION UNTIL VESSEL IS FULL OF WATER OR SHORTENING. TURNING THE KNOB TO “ON” WITH VESSEL EMPTY WILL DAMAGE THE VESSEL OR COMPONENTS AND VOID WARRANTY.**
- f. Relighting - wait 5 minutes before attempting to relight the pilot to allow for any gas in the fryer to dissipate.

Initial Cleaning

When the fryer is shipped, many of its parts are covered with a thin coat of oil for protection. Before the fryer is ready for cooking it must be cleaned. This will remove the oil coating and any foreign matter that may have accumulated during storage and shipment. Perform the cleaning as described below.

- a. Fill the vessel with water.
- b. Turn the fryer gas valve knob to the “ON” position. Allow the fryer to bring the water to a low boil and add one packet of fryer cleaner or a mild, low sudsing detergent and allow water to continue to boil for a minute, making sure water does not boil over.
- c. Turn the gas valve knob to the “PILOT” position and allow fryer to soak with the hot water for 15 minutes.

NOTICE

Do not leave the fryer unattended during cleaning. Never let the water level go below the “Min Level” mark on the back of the tank.

- d. Using the fryer cleaning brush, scrub the inside of the fryer to remove protective coating.
- e. When cleaning is complete, turn the gas valve knob to the “OFF” position and drain the water into a container suitable for hot water and dispose of it.
- f. When the tank has cooled, rinse it thoroughly with cool water. Continue to rinse the tank until the cleaner has been rinsed, thoroughly from the tank.
- g. Using a clean dry cloth, wipe out all of the water. Be very thorough removing the water, because any residual water will cause hot oil to splatter out of the fryer. Close the drain valve and remove container.

CAUTION

Mild steel tanks must be wiped down/coated with oil to keep the tank from rusting.

- h. Now that the tank is clean, you are ready to fill and operate the fryer. Refer to instructions on adding shortening to the fryer.

DAILY CLEANING

should be performed to maintain peak operation and appearance.

- a. Wipe up any shortening that spills onto the exterior of the fryer. This should be done with a clean soft cloth while the oil is still warm.
- b. Use warm water with a mild detergent to clean surfaces. Be careful not to get water in the shortening and to remove any detergent from the fry tank.
- c. Use a nonabrasive scouring powder or pad to clean stains if necessary.
- d. Perform the weekly boil out cleaning of your fryer described below.

WEEKLY FRYER CLEANING

This cleaning should include a complete draining of the fryer and a boil out.

- a. You will need a container large enough to hold 1 1/2 times the oil in one tank. This container should also be able to withstand 400° F oil temperatures.
- b. Shut fryer gas system OFF completely before performing procedures to ensure unit does not come on during any part of the cleaning operation.
- c. Drain the oil from the fryer and discard or save for reuse. Remove tube rack/mesh tube screens and remove any large debris from the bottom of the fry tank. Once clean, return tube rack/mesh screens to the fry tank. Close the drain valve and fill the fry tank with water and noncaustic detergent.
- d. Relight gas system pilot, following the lighting instructions.

- e. Turn the fryer gas valve knob to the “ON” position. Allow the fryer to bring the water to a low boil and add one packet of fryer cleaner or a mild, low sudsing detergent and allow water to continue to boil for a minute, making sure water does not boil over.
- f. Turn the gas valve knob to the “PILOT” position and allow fryer to soak with the hot water for 15 minutes.
- g. Using the fryer cleaning brush, scrub the inside of the fryer to remove protective coating.
- h. When cleaning is complete, turn the gas valve knob to the “OFF” position and drain the water into a container suitable for hot water and dispose of it.
- i. When the tank has cooled, rinse it thoroughly with cool water. Continue to rinse the tank until the cleaner has been rinsed, thoroughly from the tank.
- j. Using a clean dry cloth, wipe out all of the water. Be very thorough removing the water, because any residual water will cause hot oil to splatter out of the fryer. Close the drain valve and remove container.
- k. Now that the tank is clean, you are ready to fill and operate the fryer. Refer to instructions on adding shortening to the fryer.

WARNING

Gas units installed with casters must have a restraining device. This device must be connected at all times that the fryer is connected to the gas supply. If it is disconnected for any reason, it must be reconnected.

Thermostat Calibration Check

NOTICE

Thermostat calibration requires that the temperature of the fryer be raised above boiling. Therefore, you will need to drain the water from the fryer and fill it with oil. Before removing the water, perform the initial cleaning of the fryer. Cleaning the fryer now will prevent you from having to drain the oil and refill with water later.

To perform the calibration check detailed below you will need a digital thermometer.

- a. Place the tip of the thermometer in the shortening approximately 1" above the temperature sensors.
- b. Set the thermostat at 325°F and wait for the temperature reading on the thermometer to rise. As the temperature rises toward 325°F watch the thermometer closely.
- c. If the shortening temperature reaches 350°F and the burners DO NOT turn off, turn the thermostat down. Keep lowering the thermostat setting until the burners go out.

CAUTION

If the burners do not turn off at the lowest thermostat setting, the thermostat could be defective. Contact your representative immediately.

- d. Let the fryer cycle 4 to 6 times before checking the temperature. Compare the thermometer temperature against the thermostat setting. If the values are more than 5°F apart, calibrate the thermostat using the appropriate calibration procedure in this manual.

THERMOSTAT CALIBRATION

Millivolt thermostats

- a. Set the thermostat dial to 325°F.
- b. Remove the thermostat dial by pulling the knob straight out. DO NOT rotate the dial.
- c. Hold the outside of the shaft so it does not move. Use the tip of a small, flat tip screw driver to scrape away the sealing compound from the adjustment screw.
- d. Turn the adjustment screw clockwise to lower the temperature setting and counterclockwise to raise the temperature. One quarter turn changes the temperature approximately 25°F.
- e. Turn the adjustment until the burners turn on at 325°F. Replace the knob and allow the fryer to cycle 4 to 6 times. Check the temperature of the thermometer against the thermostat dial. If it is greater than 5° F difference, repeat the calibration procedure.
- f. When the calibration is correct, remove the thermometer and replace the tube screen.

Filling the fryer with liquid shortening

- a. Make sure the drain valve is completely closed.
- b. Fill the fryer with oil to the “Oil Level” line marked on the back of the tank.

Filling the Fryer With Solid Shortening

- a. Make sure the drain valve is completely closed.
- b. Remove the screen covering the tubes.
- c. Cut the shortening into cubes no larger than 1". ALWAYS pack the shortening below, between, and on top of the burner tubes. DO NOT leave any large air gaps. Use care when packing the solid shortening in the tank. DO NOT bend or break the temperature sensor probes. If these are damaged the fryer will not function properly.
- d. Once the fryer is packed with shortening, the shortening must be melted.
- e. To melt shortening, manually pulse the burners ON and OFF using the thermostat until the shortening is liquidized enough to cover the heat tubes. This will protect the tank and components from damage and extend the life of the oil.

Fryer Shut-Down

There are two shutdown modes of fryer operation, STANDBY and COMPLETE. The standby mode removes the ability for the fryer's main burners to cycle. Complete shutdown turns off the gas supply to the fryer. Shut down the fryer by:

STANDBY Turn the thermostat to OFF. Turn the gas valve clockwise to the PILOT position. The cooker is now in Standby and can remain this way for only brief periods of time. NEVER leave the cooker in standby overnight.

COMPLETE To completely shut down the cooker, push and turn the gas valve counterclockwise to the OFF position. The fryer is now completely shut down and can be cleaned and filtered.

TOPIC	UNDERWRITERS LABORATORY DOCUMENT	NATIONAL FUEL GAS CODE DOCUMENT
EXHAUST HOODS	ANSI/UL 710	ANSI/NFPA 96
POWER VENTILATORS	ANSI/UL 705	ANSI/NFPA 96
FILTER UNIT	ANSI/UL 586 ANSI/UL 900	ANSI/NFPA 96
TYPES OF FIRE EXTINGUISHERS AND DETECTION EQUIPMENT		
CO ₂	ANSI/UL 154	ANSI/NFPA 12
DRY CHEMICAL	ANSI/UL 299	ANSI/NFPA 17
WATER	ANSI/UL 626	ANSI/NFPA 13
FOAM	ANSI/UL 8	ANSI/NFPA 11
SPRINKLERS	ANSI/UL 199	ANSI/NFPA 13
SMOKE DETECTORS	ANSI/UL 268	ANSI/NFPA 72
FIRE DETECTION THERMOSTATS	ANSI/UL 521	ANSI/NFPA 72

IF MAINTENANCE IS REQUIRED, CONTACT YOUR LOCAL FACTORY SERVICER, LOCAL FACTORY REPRESENTATIVE, OR THE FACTORY TO OBTAIN SERVICE.

FILTER PROCEDURES

NOTE

When working with hot oil ALWAYS wear oil-proof, insulated gloves.

WARNING

NEVER • Run the filter system without a filter bag/paper.

NEVER • Empty the oil from the fryer before turning OFF the fryer burners.

NEVER • Store the UFM Filter Unit anywhere other than in the fryer filter cavity.

- a. Slide the filter pan out. Carefully remove filtered residue off the filter media. Examine the filter media for clogged or torn areas. Refer to filter media replacement instructions following this section. Reinstall the pan.
- b. Turn the fryer that is to be filtered OFF (See Standby Shutdown). Remove the baskets from the fryer tank(s). Use the clean out brush to lift out the tube screens. If there are excess crumbs in the fryer tank, remove them with the crumb scoop.
- c. If you have replaced the filter media or remove crumbs and debris, sprinkle Precoat Filter Aid on the filter paper.
- d. Check the drain spout to ensure that it is in the drain tower and over the filter pan opening.
- e. Slowly open the green handled drain valve for the tank being filtered. If necessary use the clean-brush to clear the crumbs from the drain. Use the brush to clean the sides of the tank as the oil drains.

WARNING

This filter pan is only large enough to hold the contents of one (1) tank at once, during the filter process.

- f. When the tank is empty, close the green handled drain valve. Open the red handled return valve to the tank you are filtering. This will start the pump and return the oil to the bottom of the fry tank.
- g. When bubbles are seen coming out of the oil return spout, close the red handled valve to turn the pump off. If necessary add more oil to the tank to return the oil level to the fill mark. The fryer is now ready for use.

DRAINING A TANK

The filter system is also used to drain the fryers. You will need a container capable of holding 400°F oil and protective gloves.

- a. Rotate the drain down spout so that it extends in the container that you want to drain the shortening into.
- b. Open the green handled drain valve for the tank to be drained. The oil will drain into the container you have chosen. When the container is full or the fry tank is empty, close the green handled drain valve. If the container was full repeat this step until fryer tank is empty.
- c. Once tank is completely empty add new shortening and follow fryer start up procedures.

WARNING

The power supply must be disconnected before servicing or cleaning the appliance.

FILTER MEDIA REPLACEMENT

The filter module stores neatly under the fryer when not in use. The unit is very easy to use and allows for quick installation and filtration, even under the busiest conditions. Follow the procedures below to change the filter media.

WARNING

At operating temperature, the shortening in the fryer may be hotter than 375°F (190°C). This hot, melted shortening will cause severe burns. Do not let the hot shortening touch your skin or clothing. Always wear insulated oilproof gloves when working on the filter system. It will be easier and safer if the filter assembly has cooled to room temperature before handling any filter parts.

- a. With the filter pan empty of oil, remove the filter media by grasping the filter pan handle and gently pull the assembly toward the front of the fryer.
- b. Separate the filter pickup tube from the filter pickup screen assembly by pulling up on the pickup tube just above where it connects to the pickup screen assembly. Lift pickup tube and swing it to the left, until it rests on the left hand side of the filter pan.
- c. Grab filter screen pickup assembly lift handles and carry it to a trash barrel and shake off heavy discard any debris that may be built upon the top of the assembly.
- d. Unscrew the filter paper clip bracket from the filter paper support screen and slide the filter paper support screen out of the filter paper clip bracket.
- e. Remove filter paper support screen from the filter envelope.
- f. All of the filter pick up assembly parts can be washed in a dish washer or a pot sink. Flush out the suction tube assembly with hot water. After cleaning, it is very important to thoroughly dry the parts before reassembling. Water and oil do not mix. Water in hot oil will cause the oil to splatter.
- g. Start reassembling the filter pick up assembly by sliding the new filter paper on to the filter paper support rack. Ensure that the hole in the filter paper goes over the pick up tube assembly threaded connector.
- h. Fold the open end of the bag in two folds. The first fold should be approximately 1 inch from the end and the second should be over the edge of the rack assembly.
- i. Slide the clip screen over the folded end of the filter paper. Ensure the opening of the clip screen goes over the pick up tube connection. Screw the suction tube connection onto the threaded connection.
- j. Place the filter pickup assembly into the filter pan and slide the filter pan assembly back into the fryer cabinet.
- k. Filter unit is now ready for use.

Parts Lists

Tank Assembly and Thermostat

Item	Part#	Parts Description
1	A1406702	Clamp High Limit/Thermostat
2	n/a	Screw 10-24 x 5/8 Pan Head SST Thred Forming
3	1188545	P16-PF45 36" Deeo Flue Front
	1188546	P16-PF45 36" Deep Flue Rear
	1188556	P16-PF45 42" Deep Flue Front
	1188557	P16-PF45 42" Deep Flue Rear
	1188585	P20-PF65 36" Deep Flue Front
	1188583	P20-PF65 36" Deep Flue Rear
	1188586	P20-PF65 48" Deep Flue Front
	1188584	P20-PF65 48" Deep Flue Rear
4	60131002	Ball Valve, 1-1/4" Full Port Reversible Lug, Right Hand
5	A8030407	Drain Line Piping Adapter (non-filter)
6	n/a	Steel Tank Plug 1/4" NPT
7	B3322501-C	Tank Weldment Modular P16-PF45
	B3322801-C	Tank Weldment Modular P20-PF65
8	n/a	Nut Hex 10-24 KEP Zinc
9	60130101	Tank Rear Adaptor 37.5 Flare Swivel x 1/2" NPT (filter)
	n/a	Steel Tank Plug 1/2" NPT (non-filter)
10	n/a	Screw 10-24 x 3/4" Self Tapping
11	PP10539	Knob, Thermostat With Off, 200-400F (100-200C)
12	60125401	Thermostat , RX Millivolt 200-400F
13	PP10084	Switch, Hi-limit
14	B6744401	Wiring, Millivolt Hi-Limit & Thermostat

Tank Assembly and Thermostat

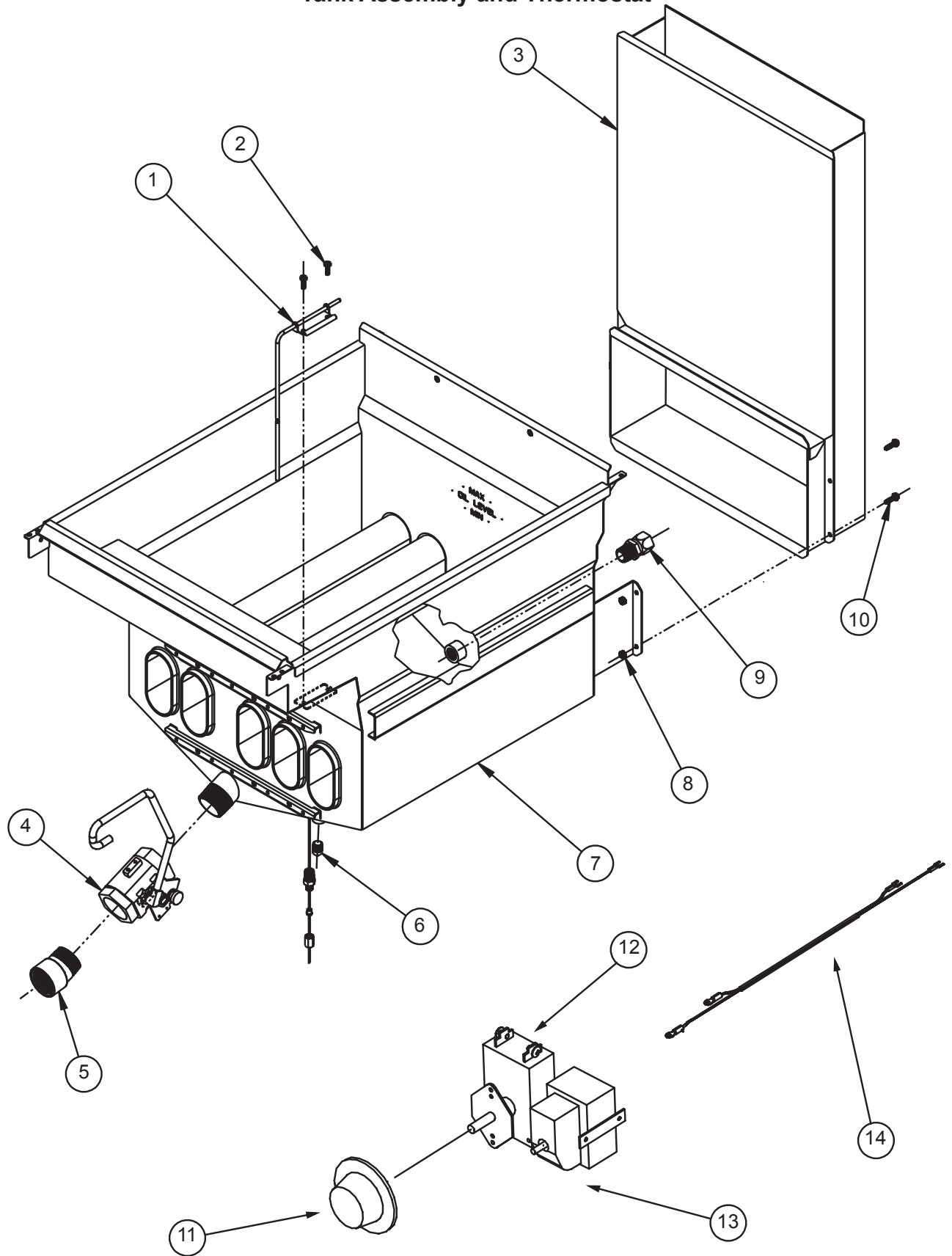

Burner Assembly

Item	Part#	Parts Description
1	B8039101	Burner Manifold Weldment P16-PF45
	B8029801	Burner Manifold Weldment P20-PF65
2	60127501	Fitting Adaptor Flared 15/16-16 UN-2A x 1/2" FNPT BRASS
3	n/a	Plug 1/8" NPT 3/16" Hex Socket Steel
4	P6071353	Orifice Tip, #53 - LP
	P6071341	Orifice Tip, #41 - NAT
5	B8037302-C	Burner, Slotted Face LP Gas
	B8037301-C	Burner, Slotted Face NAT Gas
6	n/a	Screw 10-24 x 3/8" Self Tapping
7	A7020301	Filter Return Handle Bracket
8	A7020501	Filter Return Handle Cover
9	60128801	Natural Gas Standing Pilot
	60128802	Propane Gas Standing Pilot
10	A8035302	Pilot Bracket
11	n/a	Screw 10-24 x 1/4" Hex Head SST

Burner Assembly

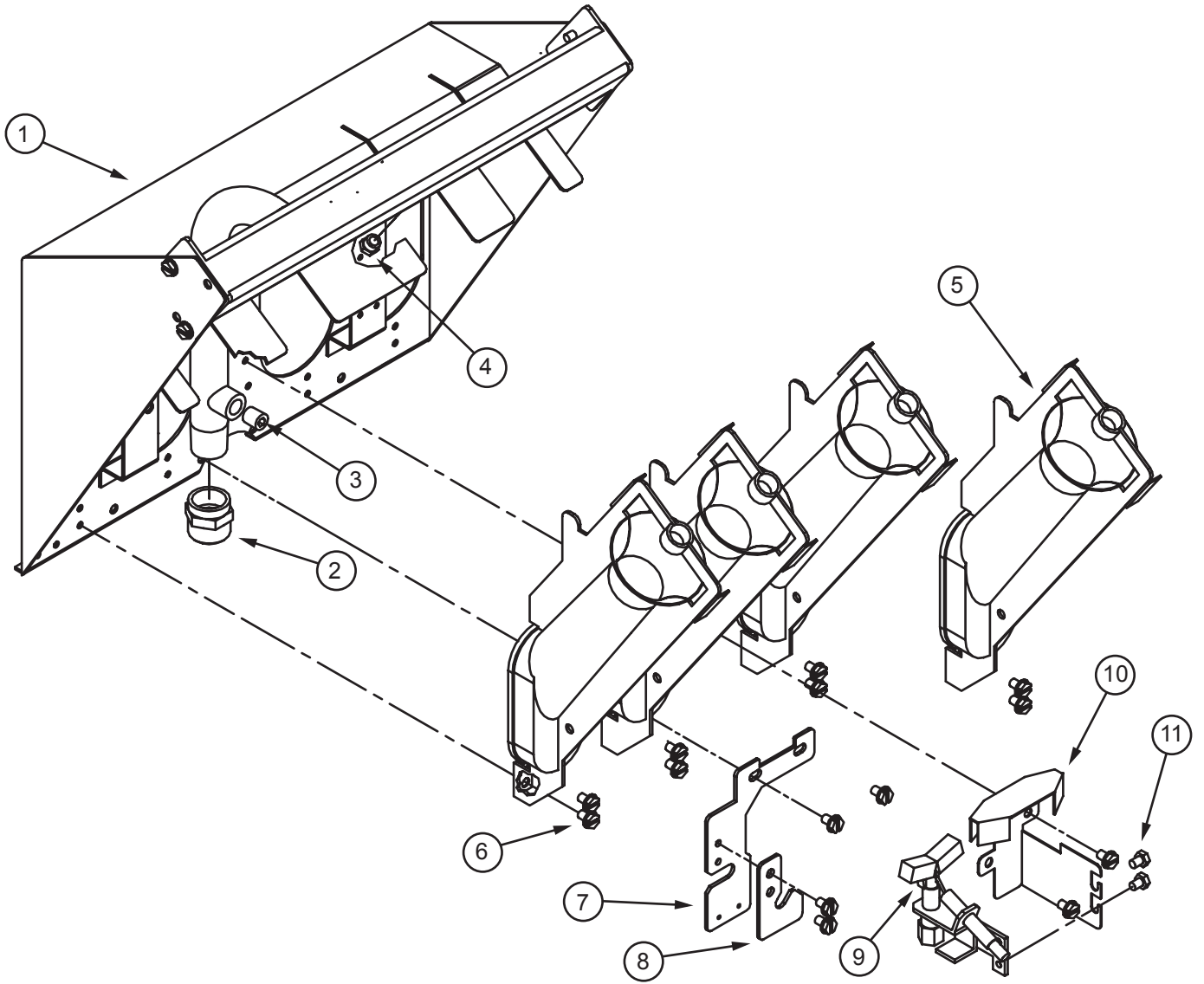

Gas Valve Assembly

Item	Part#	Parts Description
1	60128015	Tubing, Flexible With Fittings, 22 Gas
2	60128101	Valve, Gas Supply, Shut-Off
3	60127401	Fitting, Elbow Male Flare X MPT
4	60127601	Fitting, Adapter Female Swivel X 1/2 MPT
5	60126502	Conversion Kit, NAT to LP VR820
	60126501	Conversion Kit LP to NAT VR820
6	60125201-C	Millivolt Gas Valve, VS820 NAT
	60125202-C	Millivolt Gas Valve, VS820 LP
7	60119001	Tubing, Flexible Without Fittings 18 x 1/4 OD
8	60125501	Thermopile, Millivolt
9	60128801	Pilot Assembly, NAT
	60128802	Pilot Assembly, LP

Gas Valve Assembly

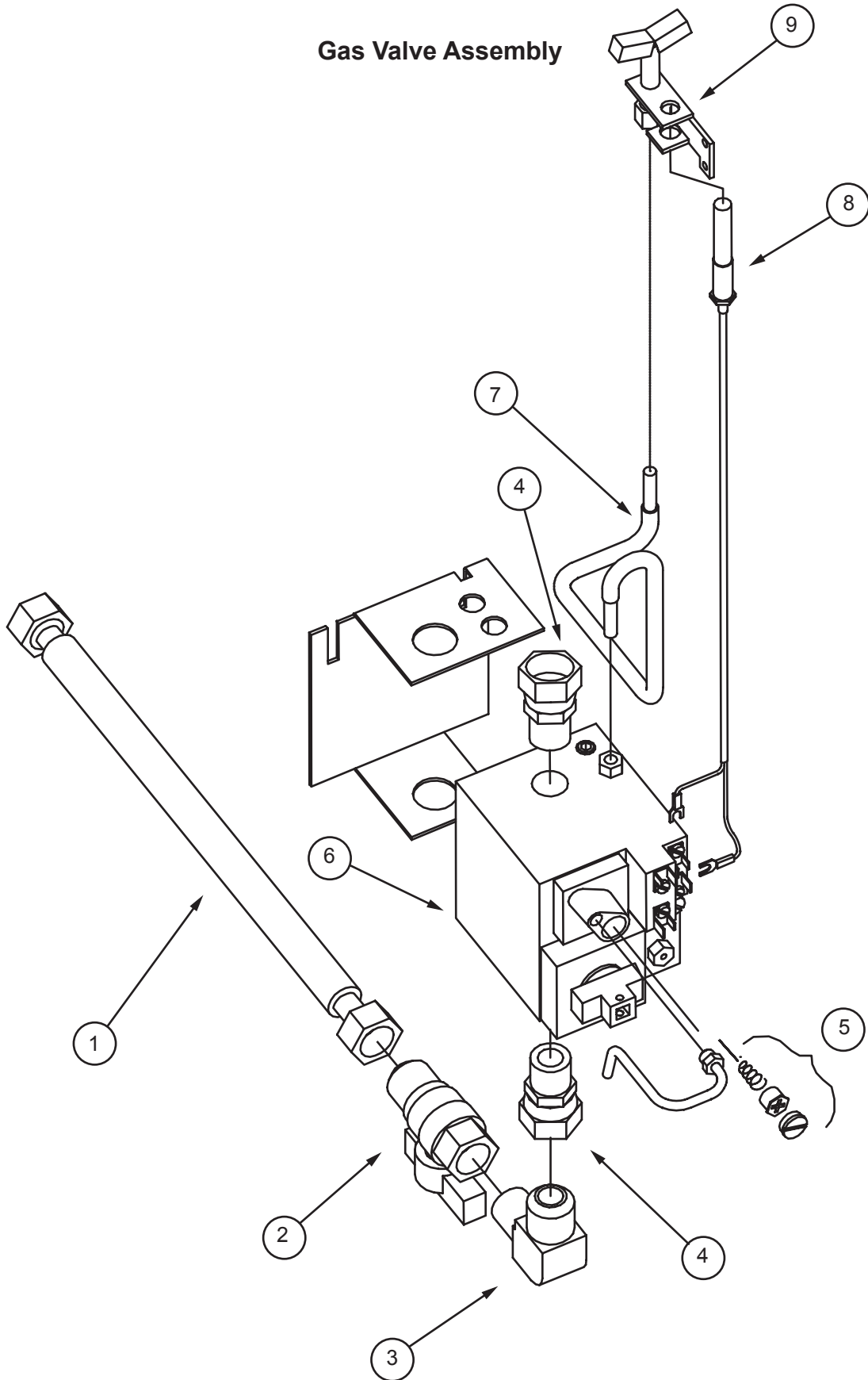

Filter Pump Assembly

Item	Part#	Parts Description
1	60132201	Teflon Hose 3/4" NPT Female Swivel x 3/4 MPT
2	B6677001	Filter Inlet Coupling
3	60131307	Nipple 3/4 NPT x 12 Black Iron
4	A7029201-C	Filter Pump Mounting PLate
5A	60143501	Pump Assembly 8GPM .3hp 115/230V (50/60hz)
	60143503	Pump Assembly 8GPM .3hp 208/240V (50/60hz)
	60143505	Pump Motor Only 8GPM .3hp 115/230V (50/60hz)
	60143506	Pump Motor Only 8GPM .3hp 115/230V (50/60hz)
	60143507	Pump Head Only 8GPM (NO MOTOR)
6	n/a	Washer 5/16 Flat
7	n/a	Nut Hex 5/16 - 18 (KEP)
8	n/a	Bolt 5/16 x 3/4
9	PP11338	Power Cord Male IEC-320 16-3 AWG
10	n/a	Elbow Black Iron 90° 3/4NPT
11	n/a	Nipple 3/4NPT x 2 Black Iron
12	n/a	Street Elbow Black Iron 90° 3/4NPT
13	60133503	Heater Tape 50W 120V 1/2 x 72
	60133504	Heater Tape 50W 240/220V 1/2 x 72
	60133508	Heater Tape 50W 208V 1/2 x 72
14	A7092201-C	Filter Piping Clamp
15	n/a	Screw 10-24 x 3/8" Self Tapping
16	A8033801	Elbow Female x Male 15/16 Flare

Filter Pump Assembly Tank Assembly and Thermostat

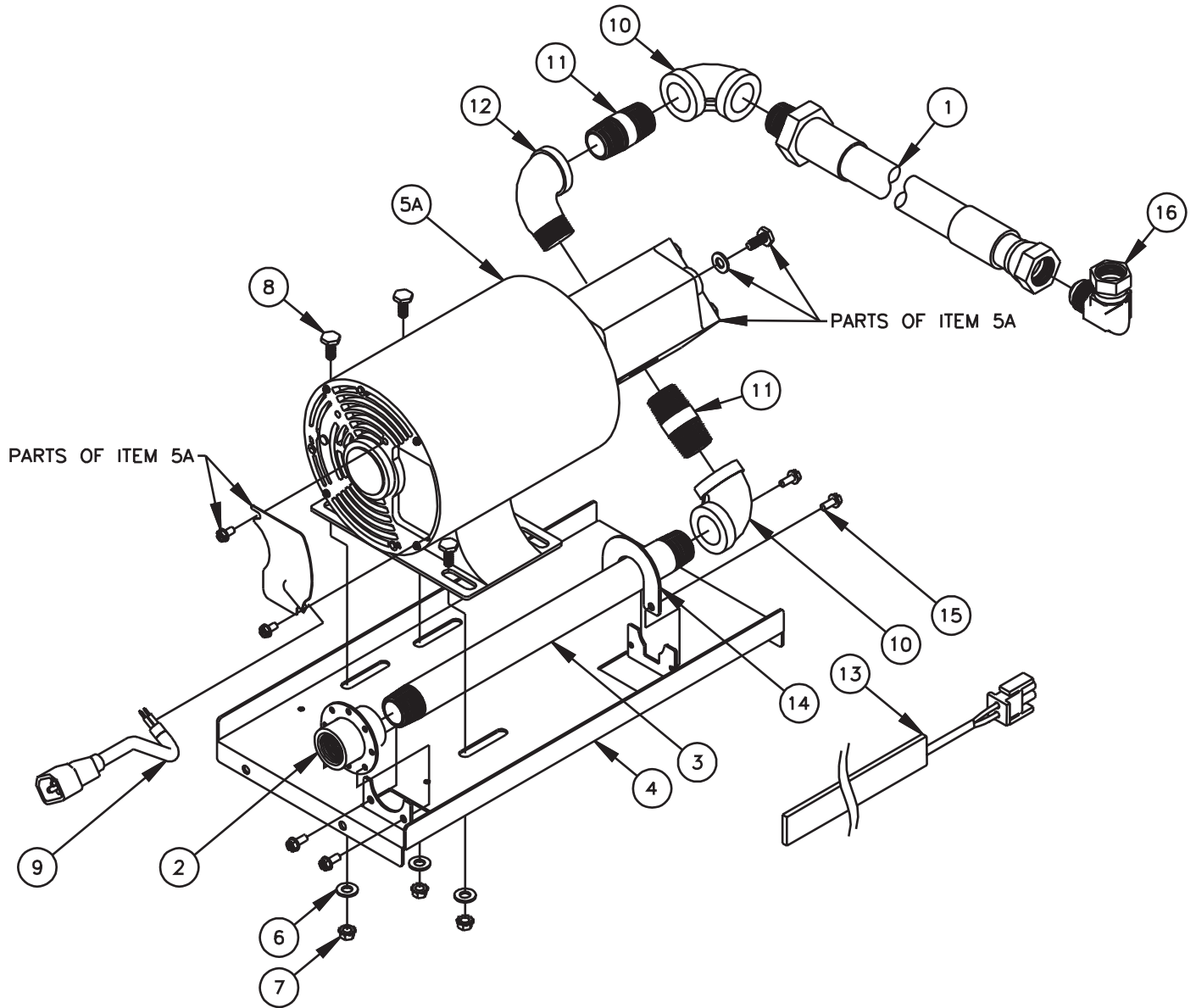

Filter Pump Control Box

Item	Part#	Parts Description
1	A7028701-C	Filter Pump Box Housing
2	B6748701	Filter Pump Box Wiring
3	60148401	Power Inlet/Outlet IEC-320
4	n/a	Nut 10-24 (KEP)
5	PP11058	Relay SPST 30A 24VAC (115V)
	60104701	Relay DPST 30A 24VAC (208/220/240V)
6	n/a	Screw 10-24 x 3/8
7	60130301	Transformer 5VA 120V
	60130302	Transformer 5VA 240V
	30130303	Transformer 5VA 208V
8	60077901	Circuit Breaker, SPST 250V 10A (115V)
	60078502	Circuit Breaker, DPST 250V 5A (208/220/240V)
9	60128403	M-F Jumper Cord IEC-320 16-3 AWG x 34"
	60128501	Cord NEMA 5-15P IEC-320 16-3 AWG x 96"
10	A1844001-C	Cable Retainer
11	60130501	Lay In Strain Relief

Filter Pump Control Box

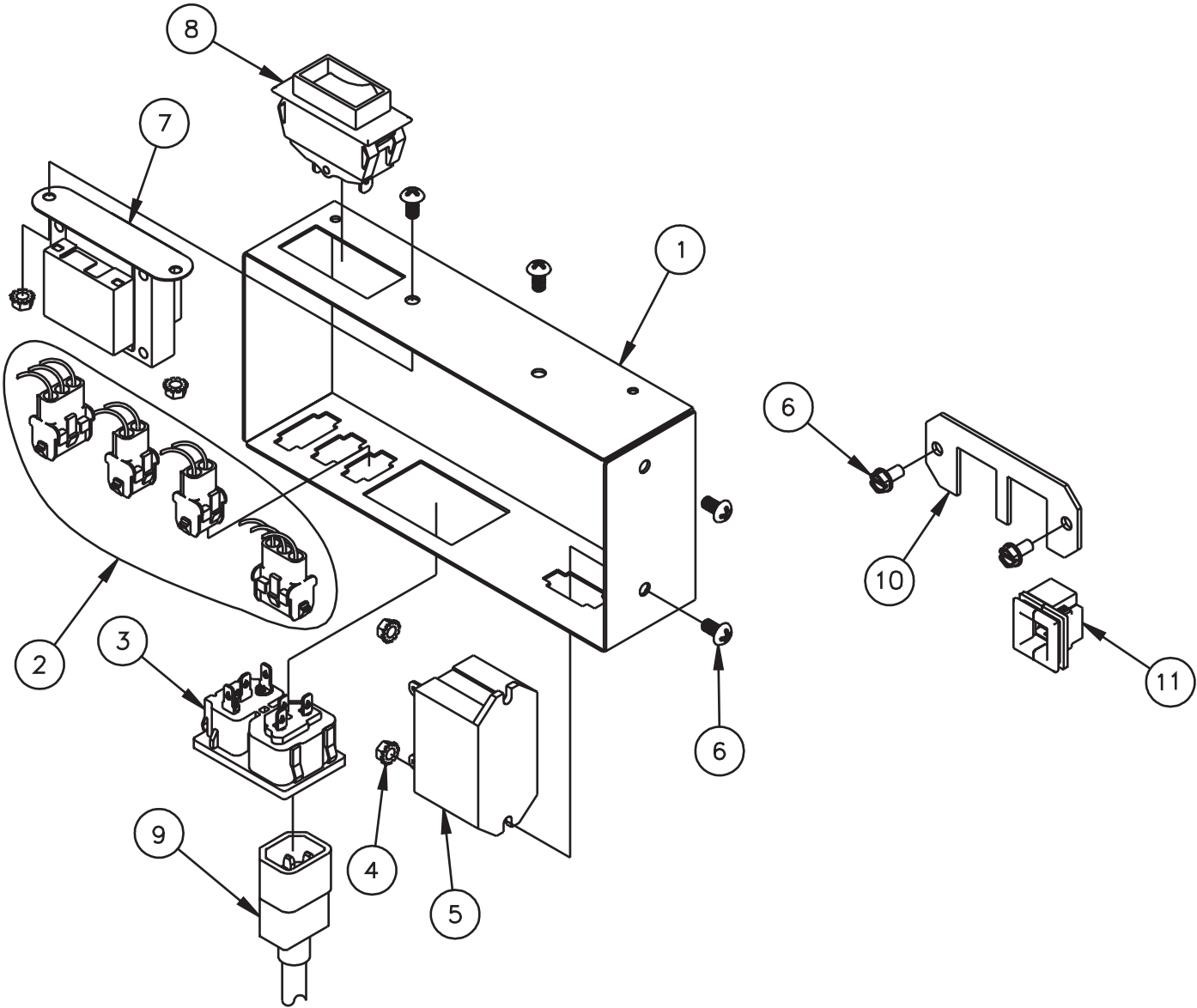

Drain Line and Filter Pan

Item	Part#	Parts Description
1	P6674401	Filter Drain Line Spout - P16-PF45
	P6674001	Filter Drain Line Spout - P20-PF65
2	B6671401	Filter Drain Fixed Elbow
3	B6675801	Filter Drain Tee
4	PP10177	Vinyl Screw Protection Cap
5	60127702	Quick Release Band Clamp
6	A7022401	Drain Line Tube PF65 - PF65
	A7022403	Drain Line Tube PF65 - PF45
	A7022405	Drain Line Tube PF45 - PF65
	A7022407	Drain Line Tube PF45 - PF45
7	60059302	Drain Line Gasket
8	60068303	Teflon O-Ring, 3" x 3.25 OD (White)
9	60068302	Viton O-Ring (Black)
10	B6671201	Filter, Strainer Cap
11	B6673901	Filter, Pickup Tube P16-PF45
	B6671001	Filter, Pickup Tube P20-PF45
12	60136301	External Retaining Ring 1-7/16"
13	60068301	O-Ring, Viton 1" ID x 1.375" OD
14	B6671102	Filter, Support Clip P16-PF45
	B6671103	Filter, Support Clip P20-PF65
15	B6664303	Filter, Support P16-PF45
	B6664304	Filter, Support P20-PF65
16	B6670802	Filter, Pan P16-PF45
	B6670801	Filter, Pan P20-PF65
17	60131401	Caster, Rigid 2.5"
18	n/a	Lock Washer #10 SST (SPLIT)
19	n/a	Screw, 10-24 x 3/8

Drain Line and Filter Pan

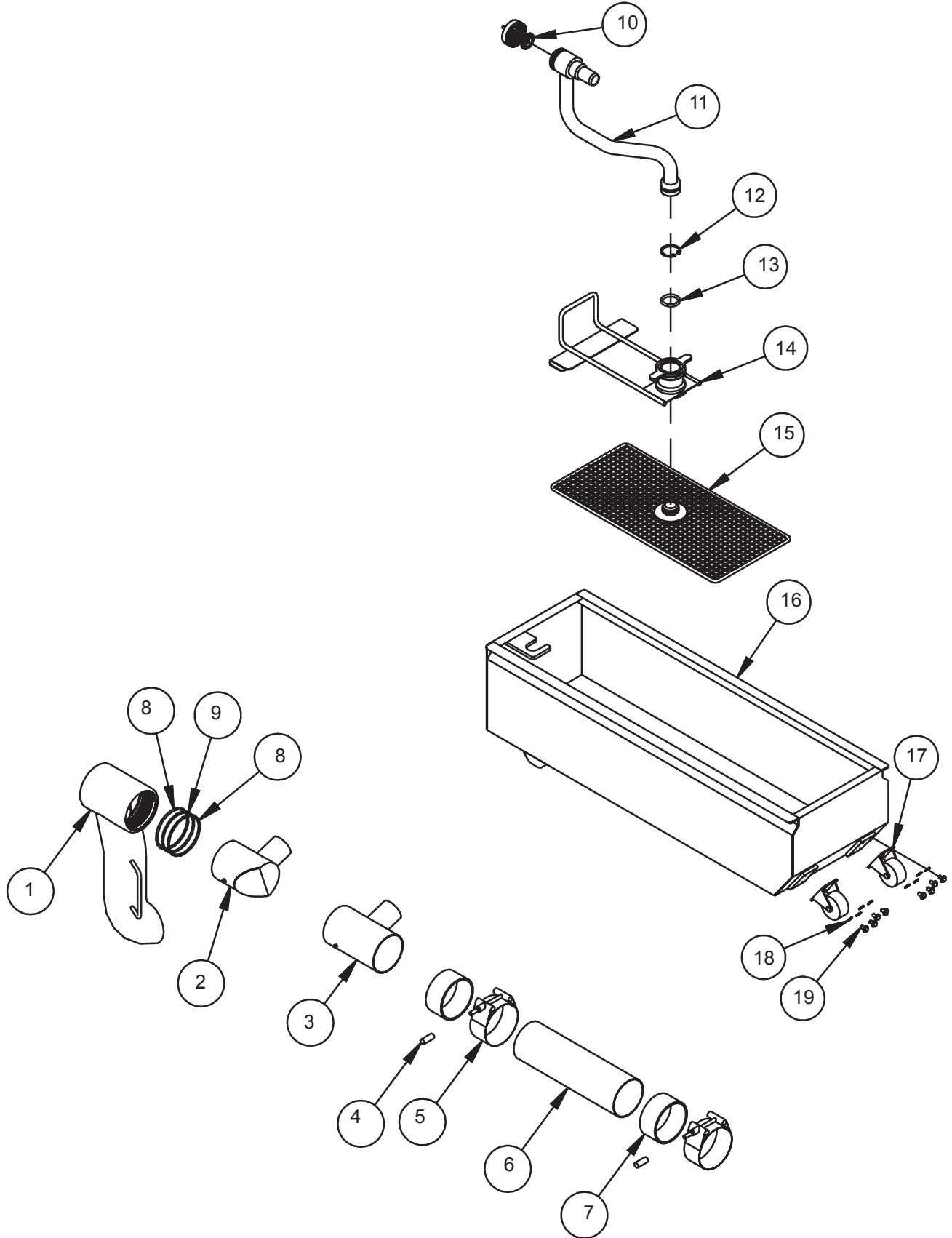

Accessories		
Item	Part#	Parts Description
1	B2101501-C	Tank Cover - P16-PF45
	B2101502-C	Tank Cover - P20-PF65
2	1186915	Basket Hanger - P16-PF45 - 36" Deep Flue
	1188591	Basket Hanger - P20-PF65 - 36" Deep Flue
	1189464	Basket Hanger - P16-PF45 - 42" Deep Flue
	1189465	Basket Hanger - P20-PF65 - 42" Deep Flue
3	A6667104	Filter Paper - P16-PF45 -18.5" x 20.5"
	PP10613	Filter Paper - P20-PF65 -20.5" x 9.92"
4	B5008101	Fryer Crumb Scoop
5	PP10056	Cleaning Brush Nylon
6	B6681201	Filter Crumb Scoop
7	A3301001	Clean-out Rod
8	P6072184	Twin Basket P20-PF65
	P6072188	Twin Basket Fine Mesh P20-PF65
	P6072145	Twin Basket P16-PF45
	P6072146	Twin Basket Fine Mesh P16-PF45
	P6072147	Triple Basket P16-PF45
	P6072185	Triple Basket P20-PF65
	P6072143	Square Bulk Basket Front Handle P16-PF45
	P6072144	Sqaure Bulk Basket Fine Mesh, Front Handle P16-PF45
	P6072181	Square Bulk Basket Front Handle P20-PF65
	P6072180	Square Bulk Basket Side Handles P20-PF65
9	P6073148	Tube Rack P16-PF45
	A4500201	Tube Screen P16-PF45
	B4511901	Tube Rack P20-PF65
	P6072186	Tube Screen P20-PF65

Accessories

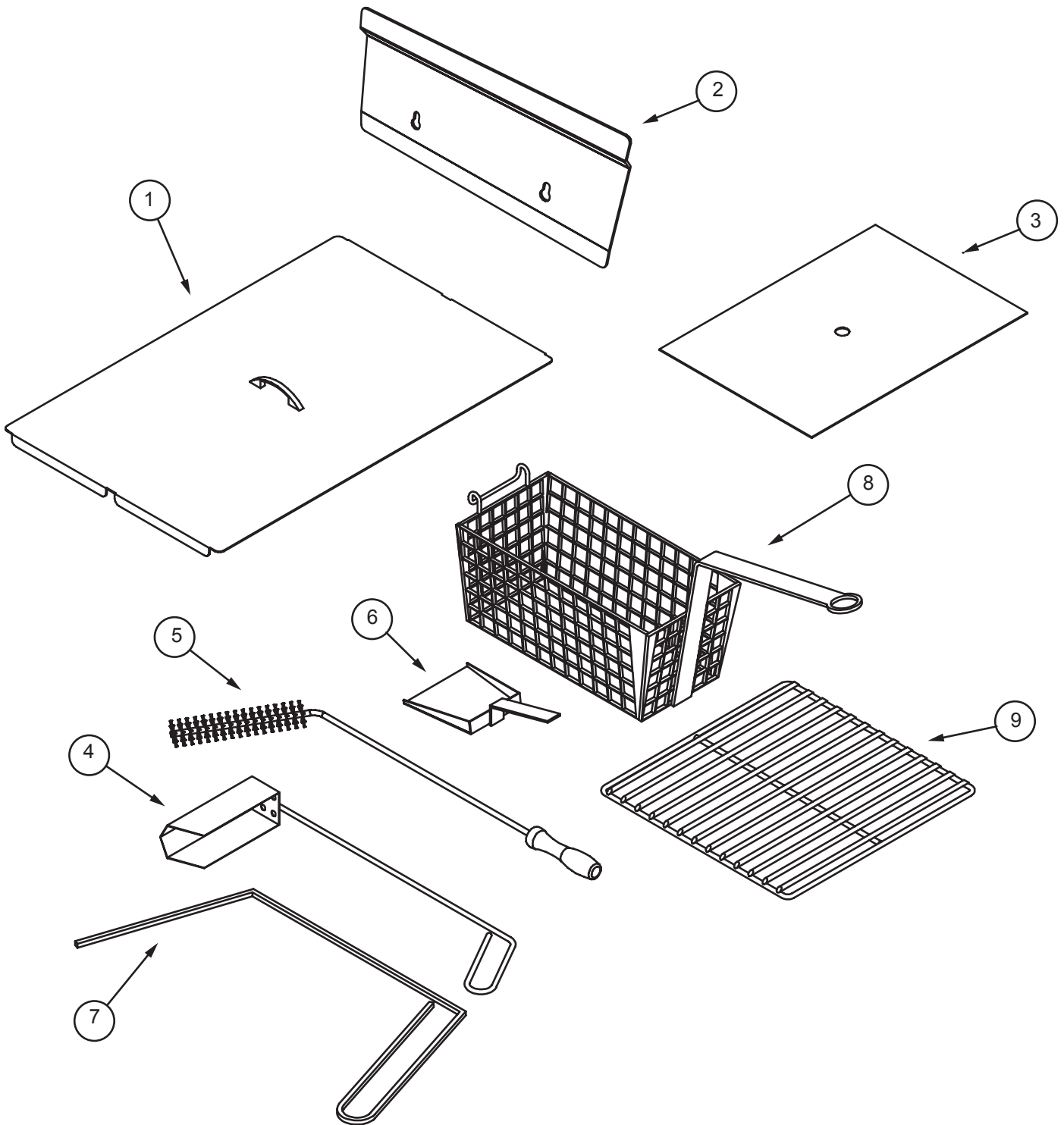

NOTES

NOTES

Fryer

Model P16-PF45, P20-PF65



A product with the **SOUTHBEND** name incorporates the best in durability and low maintenance. We all recognize, however, that replacement parts and occasional professional service may be necessary to extend the useful life of this appliance. When service is needed, contact a Southbend Authorized Service Agency, or your dealer. To avoid confusion, always refer to the model number, serial number, and type of your appliance.



Southbend
1100 Old Honeycutt Road, Fuquay-Varina, NC 27526
www.southbendnc.com - 919-762-1000