

OWNER'S MANUAL

Gas-Fired Wood-Burning
Stationary Rack Barbecue Smoker

SRG-400

SRG-800

SOUTHERN[®]
PRIDE **BBQ SMOKERS**

Southern Pride Distributing, LLC Tel 731-696-3175
401 S Mill St www.southernpride.com
Alamo, TN 38001

CONGRATULATIONS!

In selecting Southern Pride, you have chosen the finest, most advanced, and most fully automatic wood-burning barbecue smoker available. With us, "It's simply a matter of Pride".

TABLE OF CONTENTS

Safety Information and Precautions.....	3
Diagram of Smokers	4
Installation	5-12
Operation.....	13-22
Maintenance.....	23-30
Wiring Diagram.....	31
Warranty.....	32

Please read this Manual carefully prior to installation, operation, and maintenance of your Southern Pride smoker. Proper installation, operation, and maintenance are essential for your satisfaction and safe operation.

KEEP THIS MANUAL FOR REFERENCE

NOTE: An Electrical Diagram for this appliance can be found on the inside of the fan motor compartment.

This smoker may be operated outdoors.

Installation, operation, and maintenance should comply with the instructions in this manual, NFPA® 96, and other codes and standards as called out in this manual.

For more information on NFPA® 96, or to obtain a copy of the latest publication, please contact:
NFPA®, 1 Batterymarch Park, PO Box 9101, Quincy, MA 02169-7471, www.nfpa.org









Southern Pride gas-fired smokers have been tested and approved by Intertek Testing Services, are ETL listed to ANSI Z83.11, certified to CSA STD 1.8, and to NSF/ANSI Standard 4. ETL File Number 4007026



SAFETY INFORMATION AND PRECAUTIONS

This manual should be considered a permanent part of this smoker. THE SMOKER MUST BE INSTALLED BY A QUALIFIED SERVICE TECHNICIAN. All troubleshooting guides, component views, and parts lists included in this manual are for general reference only and are intended for use by qualified technical personnel.

	<p>DANGER:</p> <p>Improper installation, alteration, adjustment, service, or maintenance could result in severe injury, death, or cause property damage. Read the installation, operating, and maintenance instructions thoroughly before installing or servicing this equipment.</p>	
	<p>DANGER:</p> <p>Do not store or use gasoline or other flammable vapors or liquids in the vicinity of this or any other appliances.</p>	
	<p>CAUTION:</p>	
	<p>WARNING:</p> <p>ELECTRIC SHOCK HAZARD</p> <p>Follow these rules to avoid electric shock:</p> <ul style="list-style-type: none"> • Use only a properly grounded circuit. • Do not spray water directly on electrical components. • Turn off power before servicing. • Read the owner's manual before using. 	<p>WARNING:</p> <p>CARBON MONOXIDE POISONING HAZARD</p> <p>Carbon monoxide is a colorless, odorless gas that can kill. Follow these rules to control carbon monoxide.</p> <ul style="list-style-type: none"> • Do not use the smoker if in an unvented, enclosed area. Carbon monoxide may accumulate. • Allow only qualified burner service persons to adjust the burner. Special instruments and training are required. • Read the owner's manual before using.

1. **IT IS EXTREMELY IMPORTANT TO FOLLOW THE PRESCRIBED CLEANING INSTRUCTIONS. GREASE OR SOLIDS BUILDUP INSIDE THE SMOKER COULD RESULT IN A FIRE HAZARD.**
2. This smoker is intended for use in commercial facilities where all operators are familiar with the purpose, limitations, and associated hazards of this equipment. The operating instructions and warnings must be read and understood by all operators and users.
3. This manual and all supplied instructions, diagrams, schematics, parts lists, notices and labels must remain with the smoker even if the smoker is sold or moved to another location.
4. The area around the smoker **MUST** be kept clear and free of combustible materials, gasoline and other flammable vapors and liquids.
5. The flow of combustion and ventilating air **MUST NOT** be obstructed from reaching the smoker.
6. The frame of the smoker **MUST** be electrically grounded at all times. See "Electrical Instructions."
7. Caution should be used when opening and closing the firebox door. The door is **HOT** during operation.
8. **DO NOT** remove service compartment access panels when smoker is in operation or leave off during operation.
9. Gas burners require the services of a qualified service technician for proper setting and adjustment. If the burner does not appear to be operating properly, **DO NOT ATTEMPT TO ADJUST THE BURNER YOURSELF.**
10. **DO NOT** allow unqualified personnel to perform service work or adjustments on this smoker. Doing so, will **VOID WARRANTY** and could result in a hazardous condition.
11. Ensure new employees, who might operate the smoker, are properly instructed and supervised on the operation and safety information prior to operating the smoker.
12. Ashes removed from the firebox should be stored in a non-combustible container with a sealed lid only. Store ashes in a well ventilated area. **FUMES COULD BE HAZARDOUS.**

DIAGRAM OF SMOKERS

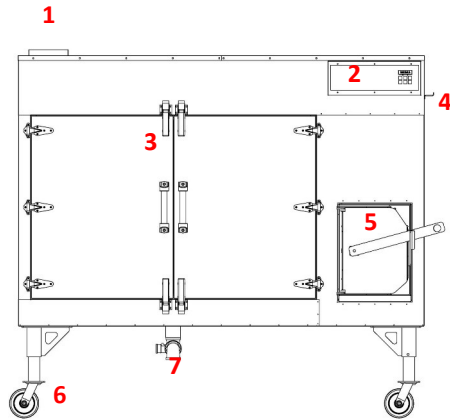
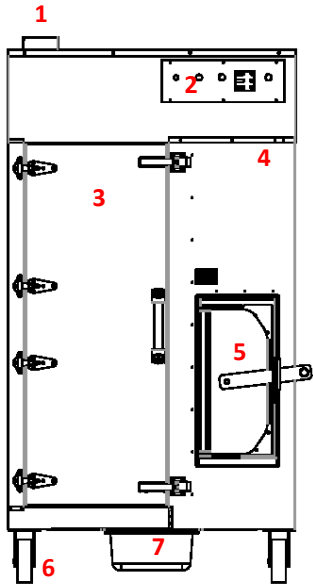

1. Flue
2. Digital cook and hold control (140 - 325°F)
3. Product loading door(s)
4. Ash pan handle hook
5. Firebox door
6. Locking castor wheels
7. Drain pan / drain valve

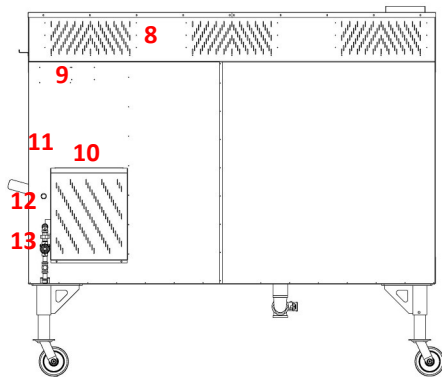
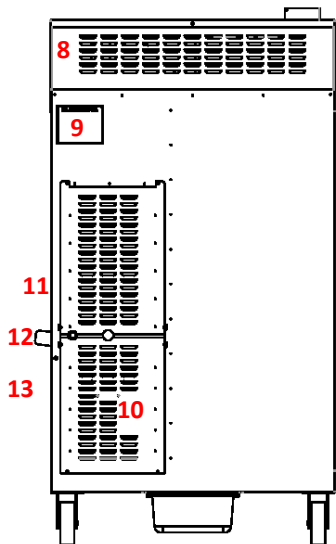

8. Control / fan motor compartment
9. Data plate
10. Service compartment cover
11. Tether / wall anchor wall mounting
12. Power cord
13. Gas supply connection

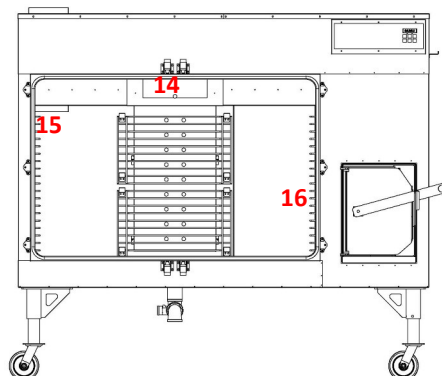
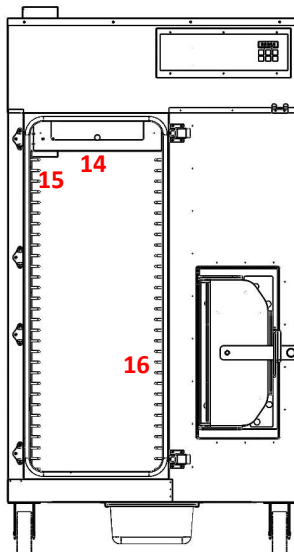

14. Blower wheel shroud
15. Thermocouple
16. High limit

INSTALLATION

RECEIVING THE SMOKER

Your smoker can be shipped via a contract hauler on a flatbed trailer, or Common Carrier. Once the smoker arrives you will need a forklift to remove the crated smoker from the truck (Common Carrier deliveries).

SRG-400:	780 lbs. uncrated base model (approx.)	1,005 lbs. crated base model (approx.)
SRG-800:	1,100 lbs. uncrated base model (approx.)	1,335 lbs. crated base model (approx.)

DELIVERY LOCATION

Commercial smokers are large and heavy. Before scheduling the delivery of your smoker have a plan and location in place to accept the delivery of the smoker and maneuver the smoker into the desired installation location. The trucker will require a flat, level surface that is safe from traffic to unload the smoker. A forklift will be required to unload the smoker. The trucker is only responsible for delivery of the smoker. It is your responsibility to unpack the smoker, move it to its installation location, and have a qualified service technician install the smoker.

UNLOADING THE SMOKER

Smokers Shipped via Contract Hauler

The driver will unload the smoker from the trailer. Once the smoker is in a level and safe place remove the white protective wrap from the outside of the smoker.

Smokers Shipped via Common Carrier

Remove the crated smoker from the truck using the appropriate forklift. Note any damage to the crate, smoker or accessories. **Do not sign the delivery bill until the smoker has been inspected and any damage noted on the delivery bill.**

The smoker is shipped strapped to a wooden pallet with an industrial cardboard carton. Once the smoker is in a level and safe place remove the cardboard carton. Located on top of the wooden pallet are two (2) wooden ramps. Fasten the ramps to the edge of the wooden pallet using the metal clasps located on the end of the pallet and ramps. The smoker is secured to the wooden pallet with metal banding straps. A board prevents the smoker from moving. After removing the banding straps securing the smoker to the wooden pallet and the board (with a Phillips screwdriver), release the brakes on each of the smokers casters. Then the smoker can be slowly and carefully rolled down the ramps secured to the pallet.



WARNING:

If the forklift forks are not long enough to support the entire smoker/crate do not attempt to move the smoker; obtain another forklift or use fork extensions.



WARNING:

Only proper heavy lifting machinery and heavy lifting equipment should be used for unloading, moving and installing the smoker. This duty should only be performed by professionals trained in this kind of work. Improper handling of the equipment could result in damaging the smoker or personal injury and even death.

INSTALLATION

UNPACKING THE SMOKER

- The ash pan handle is secured to a product rack with a plastic zip tie.
- The smoker is shipped with plastic zip ties holding the product racks to the rack slides. These zip ties should be removed prior to initial operation.
- A 6" (152mm) drain pan is located inside the smoker (SRG-400 only). The drain pan slides on the rails under the smoker.

SITE INSTRUCTIONS

The Southern Pride smoker must be installed in a location that will permit the smoker to function for its intended purpose and to allow adequate clearance for ventilation, proper cleaning, and maintenance access.

Minimum Clearance Requirement from Combustible Material

Back.....18" (457mm)	Front.....48" (1219mm)
Top.....18" (457mm)	Right & Left Side.....2" (51mm)

NOTE: If provision is made for service access, back clearance can be reduced to 2" (51mm).

WARNING:



Failure to maintain proper safety, storage, handling, and ash removal for solid fuel appliances on or around combustible materials may result in fire, property damage and/or death. Our product listing allows for the smoker to be installed on a combustible surface however, Southern Pride recommends the use of a noncombustible material for the floor surface area under the firebox, which should extend at least 6" (152 mm) beyond each side of the firebox, and outward from the smoker beyond the area needed for placement of the ash container.

INSTALLATION

ELECTRICAL INSTRUCTIONS

ELECTRICAL REQUIREMENTS:

- 120 volts AC, 60 Hz
- 15 amp required
- 2 wire (plus ground), single phase, NEMA 5-15P plug



WARNING:

This appliance, when installed, must be electrically grounded in accordance with local codes, or in the absence of local codes, with the National Electrical Code, ANSI/NFPA 70, or the Canadian Electrical Code, CSA C22.2, as applicable.

THE WARRANTY IS VOID IF THE SMOKER IS CONNECTED TO ANY VOLTAGE OTHER THAN SPECIFIED ABOVE AND ON THE SMOKER DATA PLATE. THE CHASSIS MUST BE GROUNDED TO PREVENT POSSIBLE SHOCK HAZARD.

Remove all packing material before connecting the electrical and gas supply to the smoker.

- The power is to be left OFF throughout the installation.
- The electrical service is connected via the factory supplied power cord located on the rear of the smoker.
- Install a restraining device to prevent the transmission of strain to the electrical connection.

VENTING INSTRUCTIONS

THE METHOD OF VENTILATION MUST BE APPROVED BY THE LOCAL CODE ENFORCEMENT AGENCY PRIOR TO EQUIPMENT INSTALLATION.

- The smoker ventilation system should comply with this manual and the current edition of NFPA® 96.
- It is recommended that Local Code Officials and a Commercial Kitchen Ventilation Contractor be consulted prior to installation.
- Provisions must be made for adequate air supply for the smoker. If the smoker is to be installed in a sealed room or building utilizing exhaust fans, the room must be supplied with a return air system. Return air must be equal or in excess of the exhausted air.
- The smoker should be positioned to provide a direct, or shortest, path to the outside for the exhaust duct.

TYPE-1 CANOPY HOOD VENT

All smoker models may be installed under an approved Type-1 canopy hood system rated for commercial cooking appliances.

- Placement under a common hood shared with other appliances may be prohibited.
- Southern Pride recommends a minimum 18 inch (457mm) overhang on the product loading door side of the smoker and a 6 inch (152mm) overhang on all other sides.
- Exhaust fan size must be determined by a ventilation contractor specifically for your application. Hood dimensions, exhaust duct length and routing all factor into the calculation.

INSTALLATION

GAS PIPING INSTRUCTIONS

IMPORTANT NOTES TO THE INSTALLER

- Read all instructions contained in this owner's manual before making gas connections.
- Observe all governing codes and ordinances.

WARNING:

IMPROPER GAS HOOKUP WILL VOID WARRANTY AND COULD RESULT IN A HAZARDOUS CONDITION.

1. All local and national codes and ordinances must be observed. Installation must conform with local codes or in the absence of codes, the National Fuel Gas Code ANSI Z223.1 / NFPA-54, latest edition available from The American Gas Association, Inc., 1515 Wilson Boulevard, Arlington, VA 22209.
2. The gas supply (service) line must be the same size or greater than the inlet line of the appliance. This smoker uses a 1/2" ID NPT (Sch40) inlet. Sealant on all pipe joints must be resistive to LP gas.
3. Supply line and manifold pressure should be checked with a manometer. Refer to page 12 for minimum and maximum pressures. Incoming line pressure upstream from the regulator must be 1" W.C.P. higher than the manifold pressure in order to check the regulator. The regulator used on this smoker can withstand a maximum input pressure of 1/2" PSI (14.0" W.C.P.). Over pressuring the valve may cause damage to the valve. If the line pressure is in excess of that amount, a step down regulator will be required.
4. It is recommended new pipe be used and located so that a minimum amount of work will be required in future servicing. The piping should be so installed as to be durable, substantial, and gas tight. It should be free from cutting burrs and defects in structure and threading. Cast iron fittings or aluminum tubing should not be used for the main gas circuit. Joint compounds (pipe dope) should be used sparingly on male threads only and be approved for all gases.

NOTE: The building structure should not be weakened by installation of the gas piping. The piping should not be supported by other piping, but should be firmly supported by pipe hooks, straps, bands, or hangers. Butt or lap welded pipe should not be bent.

5. **TEST PIPING FOR LEAKS.** Before turning gas under pressure into piping, all openings from which gas can escape must be closed. Immediately after turning on gas, the system should be checked for leaks. This can be done by watching the 1/2 cubic foot test dial for 5 minutes to show any movement, or by soaping each pipe connection and watching for bubbles. If a leak is found, make the necessary repairs and repeat the above test.

NOTE: Defective pipes or fittings should be replaced and not repaired. Never use a flame or fire of any form to locate gas leaks, use a soap solution.

6. After the piping and meter have been checked completely, **PURGE THE SYSTEM OF AIR. DO NOT** bleed the air inside the smoker. Be sure to relight all the gas pilots on other appliances.

NOTE: The burner and its individual shutoff valve must be disconnected from the gas supply piping system during any pressure testing in excess of 1/2 psig.

INSTALLATION

GAS PIPING INSTRUCTIONS (continued)

Pipe Sizing Chart for Natural Gas (0-0.5 psi) with Straight Schedule 40 Metal Pipe

The following chart is based on 0-0.5 psi inlet pressure, specific gravity of 0.6, and a pressure loss of 0.5" w.c.

Maximum Capacity of Pipe Size in Btu per Hour

Pipe Size	1/2"	3/4"	1"	1 1/4"	1 1/2"
Pipe Length (ft)	Maximum Capacity in Btu/hr				
10	175,000	360,000	680,000	1,400,000	2,100,000
20	120,000	250,000	465,000	950,000	1,460,000
30	97,000	200,000	375,000	770,000	1,180,000
40	82,000	170,000	320,000	660,000	990,000
50	73,000	151,000	285,000	580,000	900,000
60	66,000	138,000	260,000	530,000	810,000
70	61,000	125,000	240,000	490,000	750,000
80	57,000	118,000	220,000	460,000	690,000
90	53,000	110,000	205,000	430,000	650,000
100	50,000	103,000	195,000	400,000	620,000
150	40,000	84,000	160,000	325,000	500,000
200	35,000	72,000	135,000	280,000	430,000

Pipe Sizing Chart for Liquid Propane (11" w.c.) with Copper Tubing

The following chart is based on 11" w.c. inlet pressure and a pressure drop of 0.5" w.c.

NOTE: Copper tubing shall comply with standard type K or L of ASTM B 88 or STM B 280.

Maximum Capacity of Tube Size in Btu per Hour

Pipe Size	1/2"	5/8"	3/4"	7/8"
Pipe Length (ft)	Maximum Capacity in Btu/hr			
10	110,000	206,000	348,000	536,000
20	76,000	141,000	239,000	368,000
30	61,000	114,000	192,000	296,000
40	52,000	97,000	164,000	253,000
50	46,000	86,000	146,000	224,000
60	42,000	78,000	132,000	203,000
70	38,000	71,000	120,000	185,000
80	36,000	67,000	113,000	174,000
90	33,000	62,000	105,000	161,000
100	32,000	59,000	100,000	154,000

INSTALLATION

GAS PIPING INSTRUCTIONS (continued)

Pipe Sizing Chart for Liquid Propane (11" w.c.) with Straight Schedule 40 Metal Pipe

The following chart is based on 11" w.c. inlet pressure and a pressure drop of 0.5" w.c.

Maximum Capacity of Pipe Size in Btu per Hour

Pipe Size	1/2"	3/4"	1"	1 1/4"	1 1/2"	2"	3"
Actual ID	0.622	0.824	1.049	1.38	1.61	2.067	3.068
Pipe Length (ft)	Maximum Capacity in Btu/hr						
10	291,000	608,000	1,145,000	2,352,000	3,523,000	6,786,000	19,119,000
20	200,000	418,000	787,000	1,616,000	2,422,000	4,664,000	13,141,000
30	160,000	336,000	632,000	1,298,000	1,945,000	3,745,000	10,552,000
40	137,000	287,000	541,000	1,111,000	1,664,000	3,205,000	9,031,000
50	122,000	255,000	480,000	984,000	1,475,000	2,841,000	8,004,000
60	110,000	231,000	434,000	892,000	1,337,000	2,574,000	7,253,000
80	94,000	197,000	372,000	763,000	1,144,000	2,203,000	6,207,000
100	84,000	175,000	330,000	677,000	1,014,000	1,952,000	5,501,000
125	74,000	155,000	292,000	600,000	899,000	1,730,000	4,876,000
150	67,000	140,000	265,000	543,000	814,000	1,568,000	4,418,000
200	58,000	120,000	227,000	465,000	697,000	1,342,000	3,781,000
250	51,000	107,000	201,000	412,000	618,000	1,189,000	3,351,000
300	46,000	97,000	182,000	373,000	560,000	1,078,000	3,036,000
350	42,000	89,000	167,000	344,000	515,000	991,000	2,793,000
400	40,000	83,000	136,000	320,000	479,000	922,000	2,599,000

INSTALLATION

GAS CONNECTION INSTRUCTIONS

For smokers equipped with casters, the installation shall be made with a connector that complies with the Standard for Connectors for Movable Gas Appliances, ANSI Z21.69 CSA 6.16, and a quick-disconnect device that complies with the Standard for Quick-Disconnect Devices for Use With Gas Fuel, ANSI Z21.41 CSA 6.9.

Adequate means must be provided to limit the movement of the appliance without depending on the connector and the quick-disconnect device or its associated piping to limit the appliance movement.

A restraining device may be attached using the mounting hole provided on the rear of the smoker. Refer to page 4 to locate the mounting hole.

WARNING: Operator should be aware that a restraint device is in place on smokers equipped with casters. If disconnection of the restraint is necessary, it must be reconnected after the appliance has been returned to its originally installed position.

IMPORTANT ITEMS TO CHECK BEFORE FIRING THE BURNER

1. Gas line **MUST** be installed by a qualified technician and in accordance with this manual.
2. Gas line **MUST** include an easily accessible manual shutoff valve, drip leg, and pressure gauge port.
3. Gas pipe size **MUST** be in accordance with the Pipe Capacity Chart in this manual (pages 9 and 10).
4. Gas line **MUST** be tested for leaks under pressure.
5. Gas line **MUST** be purged to remove any air in the system.
6. Gas line pressure **MUST** be checked and **MUST NOT** exceed the maximum pressure specified in the Burner Specifications on page 12.
7. Burner orifice **MUST** correlate with the type of gas being supplied, as specified in the Burner Specifications on page 12.



WARNING:

Improper gas hookup will void the warranty and could result in a hazardous condition.

INSTALLATION

BURNER SPECIFICATIONS

Burner Model: Wayne P265-EP

Fuels: Natural or L.P. Gases

Electrical: 120 VAC, 60 Hz, 1 phase

NOTE: Orifice and valve setting must correlate with type of gas being supplied.

Firing Capacity		
Firing Rate Btu	65,000	100,000
KW	19	29
SRG-400	X	
SRG-800		X

Pilot Orifice Size Chart	
Natural	BCR-24
LP	BCR-18

Main Orifice Size Chart		
65,000 Btu/hr 19 KW/hr	Natural Gas	#26 (.147")
65,000 Btu/hr 19 KW/hr	LP Gas	#43 (.089")
100,000 Btu/hr 29 KW/hr	Natural Gas	#13 (.185")
100,000 Btu/hr 29 KW/hr	LP Gas	#36 (.107")

	Gas Supply Line Pressure		Manifold Pressure	
	Minimum	Maximum	Minimum	Maximum
Natural	4.5" w.c. 11.2 mbar	10.0" w.c. 24.9 mbar	3.0" w.c. 7.5 mbar	3.5" w.c. 8.7 mbar
LP	11.0" w.c. 27.4 mbar	13.0" w.c. 32.4 mbar	9.5" w.c. 23.7 mbar	10.0" w.c. 24.9 mbar

Gas Valve
Knob must be in ON (vertical) position.



Supply gas pressure test port

OPERATION

The smoker should be operated in the following order (with all operations according to the subsequent instructions):

1. Ensure that the drain pan is empty/drain valve is closed.
2. Set the control and start the cook cycle.
3. Once the smoker reaches the temperature set point, pause the menu, load the product into the smoker and close the product loading door.
4. Place the desired wood into the firebox, close the firebox door and resume the menu.
5. Once the cook cycle is complete, turn the control off.
6. Remove the product from the smoker.
7. Remove the ashes from the firebox.
8. Empty/drain the grease.

NOTE

The smoker temperature may exceed the thermostat's setting on initial heat-up as the cabinet absorbs the heat.

CRITICAL TEMPERATURES AND COOKING CHART

Product	Cook Temp	Cook Time	Internal Temp
Beef Brisket	225°F	6 - 12 hours	Safe at 145°F (USDA), 190° - 205°F for tender
Chicken (whole)	250°F	2 - 4 hours	165°F (USDA)
Chicken (half)	250°F	2 - 4 hours	165°F (USDA)
Chicken (quarter)	250°F	2 - 2.5 hours	165°F (USDA)
Chicken (wings & legs)	300°F	1 - 1.5 hours	165°F (USDA)
Pork Butt	225°F	10 - 12 hours	Safe at 145°F (USDA), 190° - 205°F for tender
Pork Loin	225°F	2 - 3 hours	145°F (USDA) *See note below
Pork Ribs	250°F	3 - 4 hours	145°F (USDA)
Turkey (whole)	250°F	3 - 6 hours	165°F (USDA)
Turkey (leg)	300°F	3 - 5 hours	Safe at 165°F (USDA), 190°F for tender
Turkey (breast)	250°F	2.5 - 3 hours	165°F (USDA) *See note below

Cooking times are approximate and will vary depending on many factors including product size/weight, beginning internal temperature and preferred doneness/skin texture.

*For lean proteins, consider removing from the smoker 5-10 degrees before reaching desired internal temperature to rest for 30 minutes to retain juices. The internal temperature will continue to climb a few degrees and the protein will remain moist.

OPERATION

CONTROL OPERATING INSTRUCTIONS

DIGITAL COOK & HOLD CONTROL - Manual Menu

1. The product loading door must be closed.
2. The display must read IDLE. (The burner, and convection fan will be off). If the display reads OFF, a press of any button will bring the control to IDLE.
3. A menu consists of a cook temperature, cook time, and, when the cook time has elapsed, a choice to end the menu (HOLD OFF) or go into hold mode (HOLD TEMP SETPOINT).
4. Press the manual menu button (TENP1 will be displayed), then press the up/down buttons to obtain the desired cook temperature.
5. Press the manual menu button (TINE1 will be displayed), then press the up/down buttons to obtain the desired cook time.
6. Press the manual menu button (HTENP will be displayed), press the up/down buttons to obtain the desired hold temp, if a hold temp is not desired press the down button until OFF is displayed.
7. Programming the menu is complete. To start the menu, press the start/stop button one time. The control will begin the menu.
8. To pause the menu, press the start/stop button one time and PAUSE will be displayed. To resume the menu, press the start/stop button one time.
9. To cancel or stop the menu, press and hold the start/stop button until IDLE is displayed.
10. Once the smoker has reached the temperature set point an audible alarm will sound. A press of any button on the control will stop the alarm. After two minutes the alarm will stop; if no button is pressed.
11. When the cook cycle is complete there are two possible actions that can be taken. One is if a hold temperature was programmed into the menu, the control will momentarily sound an audible alarm then, HOLD and the length of time the control has been in the hold mode will alternately flash in the display. The control will maintain the hold temperature until the start/stop button is depressed to END the menu, and bring the control to the IDLE mode.
12. If the hold temperature was programmed to OFF and the cook time has elapsed, END will be displayed, and an audible alarm will sound continuously until the start/stop button is depressed, to END the menu, and bring the control to the IDLE mode.
13. After the control has been in the IDLE mode for five minutes it will go to OFF, a press of any button will bring the control back to IDLE.
14. After each cook cycle the ashes should be removed from the firebox and the grease emptied/drained.

NOTE: When the control is in IDLE the convection fan will continue to run until the smoker temperature falls below 120°F (49°C), or for five minutes, whichever occurs first.

OPERATION

CONTROL OPERATING INSTRUCTIONS (continued)

DIGITAL COOK & HOLD CONTROL - Automatic Menu Programming

1. The product loading door must be closed.
2. The display must read IDLE. (The burner, and convection fan will be off). If the display reads OFF, a press of any button will bring the control to IDLE.
3. A menu consists of a cook temperature, cook time, and, when the cook time has elapsed, a choice to end the menu (HOLD OFF) or go into hold mode (HOLD TEMP SETPOINT).
4. Press and hold the up and down buttons for 10 seconds to access the menu program state (M 1 will be displayed).
5. Press the manual menu button to access the menu parameters for menu 1 (STPT1 will be displayed), this is the set point temperature for the menu.
6. Press the manual menu button again to change the cook temperature. Use the up/down buttons to obtain the desired cook temperature. Press the enter button to save the change.
7. Press the down button to advance to cook time (TINE1 will be displayed). To change the cook time, press the manual menu button. Use the up/down buttons to obtain the desired cook time. Press the enter button to save the change.
8. Press the down button to advance to hold temperature (HSTPT1 will be displayed). To change the hold temperature, press the manual menu button. Use the up/down buttons to obtain the desired hold temperature, if a hold temperature is not desired press the down button until OFF is displayed. Press the enter button to save the change.
9. Programming the menu is complete. Press the enter button to return to the menu list. Use the up/down buttons to select the next menu to program. Repeat the above steps to program the next menu. Once programming is complete, press the enter button twice to return to IDLE.

OPERATION

CONTROL OPERATING INSTRUCTIONS (continued)

DIGITAL COOK & HOLD CONTROL - Automatic Menu Operation

1. The product loading door must be closed.
2. Press the auto menu button. The number of the first automatic menu will be displayed.
3. Use the up/down buttons to scroll through the list of automatic menus. When the desired menu number is displayed, press the start/stop button to start the menu.
4. To pause the menu, press the start/stop button one time and PAUSE will be displayed. To resume the menu, press the start/stop button one time.
5. To cancel or stop the menu, press and hold the start/stop button until IDLE is displayed.
6. Once the smoker has reached the temperature set point an audible alarm will sound. A press of any button on the control will stop the alarm. After two minutes the alarm will stop; if no button is pressed.
7. When the cook cycle is complete there are two possible actions that can be taken. One is if a hold temperature was programmed into the menu, the control will momentarily sound an audible alarm then, HOLD and the length of time the control has been in the hold mode will alternately flash in the display. The control will maintain the hold temperature until the start/stop button is depressed to END the menu, and bring the control to the IDLE mode.
8. If the hold temperature was programmed to OFF and the cook time has elapsed, END will be displayed, and an audible alarm will sound continuously until the start/stop button is depressed, to END the menu, and bring the control to the IDLE mode.
9. After the control has been in the IDLE mode for five minutes it will go to OFF, a press of any button will bring the control back to IDLE.
10. After each cook cycle the ashes should be removed from the firebox and the grease emptied/drained.

NOTE: When the control is in IDLE the convection fan will continue to run until the smoker temperature falls below 120°F (49°C), or for five minutes, whichever occurs first.

OPERATION

PRODUCT LOADING INSTRUCTIONS

1. Before opening the product door, the control should be in the IDLE or PAUSE position.
2. Remove the product rack from the smoker.
3. Place the product directly on the product rack, leaving an air gap between each piece of product.
4. With the product placed on the food rack, carefully slide the loaded product rack into the smoker starting from the bottom rack slide position.
5. Repeat steps 2 and 3 until all product is loaded into the smoker. Product height will determine how many rack slide spaces you need to advance to maintain an air gap between each loaded product rack.
6. If the cook menu was paused, a press of the start/stop button is required to resume the menu.

FIREBOX LOADING INSTRUCTIONS

1. The solid fuel should be handled in accordance with NFPA® 96.
2. Southern Pride recommends that the smoker be allowed to reach the temperature set point (the audible alarm will sound) before loading wood into the firebox. This will help prevent the smoker from exceeding the temperature set point.
3. Before opening the firebox door, the control should be in the IDLE or PAUSE position.
4. Use 1-3 logs, 3-5 inches (76 - 127mm) in diameter, 10-12 inches (254 - 305mm) long. Use green or slightly seasoned hardwoods, fruitwoods, or charcoal (not to exceed six pounds, 2.7kg). **THE WOOD OR CHARCOAL IS ONLY USED TO FLAVOR THE PRODUCT, NOT TO HEAT THE SMOKER.**
5. Be sure to keep the wood 4 inches (102mm) from the burner or ashes can accumulate on the burner and cause it to not work properly.
6. Place the logs on top and inline with each other to minimize air flow around each log. This will help promote a smoldering, slow burn, which maximizes smoke.
7. The wood shall not be lit manually; the smoker is equipped with a gas burner that will light the wood. Combustible or flammable liquids shall not be used to assist ignition.
8. Tightly close the firebox door to prevent air from being pulled into the firebox.
9. If the cook menu was paused, a press of the start/stop button is required to resume the menu.

CAUTION:

- Remove coals and ashes from previous cook cycle before loading new wood into the firebox. Refer to Ash Removal Instructions on page 18.
- Do not use dry wood or kindling.
- Do not overload firebox. Too much wood or charcoal can cause overheating of the smoker. Keep wood at least 4 inches (102mm) from the burner.
- Do not allow ashes in or near the burner opening.

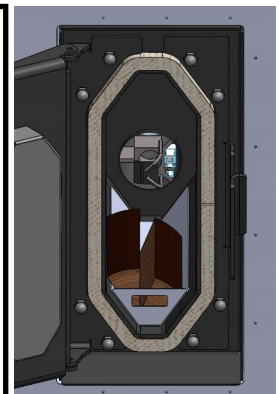



OPERATION

PRODUCT UNLOADING INSTRUCTIONS

1. Before unloading the product, the control should be in the IDLE or OFF position.
2. Carefully open the product loading door just enough to release the smoke from the cabinet, then wait approximately 5 seconds before fully opening the product loading door.
3. Product should be removed from top rack to the bottom rack.

ASH REMOVAL INSTRUCTIONS

1. The ashes should be handled in accordance with NFPA® 96.
2. Before emptying the firebox, the control should be in the IDLE or OFF position.
3. After each cook cycle, remove the remaining wood and hot coals from firebox. Use heat resistant gloves while handling ash container and ash removal tools. The ash pan handle should be used to remove the ash pan from the firebox. The end of the ash pan handle is inserted into the opening in the end of the ash pan. The two hooks on the ash pan handle grip the opening in the ash pan and leverage is used as the ash pan is removed from the firebox.
4. Place small lots of them in a noncombustible corrosion resistant pan and spray with water. A noncombustible corrosion resistant pan should be kept just outside the firebox door for this purpose.
5. Once wood and ash have been sprayed, place them in a heavy metal container with a tight fitting metal lid (16 gauge (1.59mm) minimum, capacity not to exceed 20 gallon (76 liters)). This container shall be assigned for this one purpose, shall be able to be handled easily by any employee assigned the task, and shall pass easily through any passageway to the outside of the building. The container shall always be covered when it is being moved through the premises. When any hole occurs in a container from corrosion or damage, the container shall be repaired or replaced immediately.
6. The ashes should be carried to a separate heavy metal container (or dumpster), outside the premises, that is used exclusively for the purpose of hot ash storage.

	<p>WARNING</p> <p>Never empty ash/coals from the smoker into a common trash dumpster. Embers from ash/coals could ignite materials resulting in a fire.</p>
	<p>CAUTION</p> <p>Be sure smoker product loading door and firebox door are secured in the closed position immediately following a cook cycle and during non-use periods.</p>

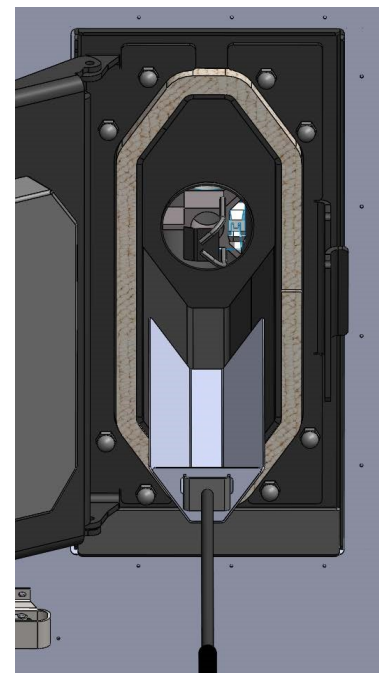

OPERATION

GREASE REMOVAL INSTRUCTIONS

1. Immediately empty/drain the grease after each cook cycle. **CAUTION: Grease will be hot.**
2. Open the valve slowly (SRG-800).
3. Grease should be poured into an approved grease recycling bin.



WARNING

Do not connect the grease drain on the smoker (SRG-800) directly to the building drain system, or any other drain connection.



WARNING

Do not remove the drain pan (SRG-400), or open the drain valve (SRG-800) while the smoker is still in operation or while burning wood and hot coals are still in firebox.

WOOD STORAGE INSTRUCTIONS

- The solid fuel should be stored in accordance with NFPA® 96.
- Wood stored in the same room as the smoker or the smoker firebox door shall not exceed a 1-day supply.
- Wood shall not be stored above any heat-producing appliance or vent or closer than 0.92 m (3ft) to any portion of a solid fuel appliance constructed of metal or to any other cooking appliance that could ignite the wood.
- Wood shall not be stored in the path of ash removal.
- Where stored in the same building as the smoker, wood shall be stored only in an area with walls, floor and ceiling of noncombustible construction extending at least 0.92m (3ft) past the outside dimension of the storage pile.
- Wood shall be separated from all flammable liquids, all ignition sources, all chemicals, and all product supplies and packaging goods.
- All wood storage areas shall be provided with a sprinkler system meeting the requirements of NFPA® 13.

Exceptions:

- Where acceptable to the authority having jurisdiction, wood storage areas shall be permitted to be protected with a fixed water pipe system with a hose capable of reaching all parts of the area.
- In lieu of a sprinkler system a listed 2-A rated water spray extinguisher or a 6 L (1.6 gal) wet chemical fire extinguisher listed for Class K fires with a maximum travel distance of 6 m (20 ft.) to the wood piles shall be permitted to be used for a wood pile, provided that the wood pile does not exceed 0.14 cubic meters (5 cubic feet) volume.

OPERATION

MOBILE SMOKER OPERATION

- Check the fuel level of the LP tanks prior to starting a cook cycle. Proper monitoring of the LP tanks will eliminate the chance of running out of gas.
- The burner in the smoker is equipped with an automatic ignition system. **Do not attempt to manually light the burner.**
- Do not transport the smoker while the smoker is in operation or with product on the product racks.
- Disconnect the electrical power supply before removing the service compartment access panels for servicing.
- Do not transport the smoker with hot coals or a wood fire in the firebox.
- Never place anything over the flue of the smoker, it must be unobstructed to work properly.
- Never attempt to cook with the product door, or firebox door, open.
- **Dry wood, too much wood, or too much charcoal may cause the temperature in the smoker to override the thermostat setting.** Follow instructions in this manual for the proper amount of wood or charcoal to use.

MOBILE SMOKER ELECTRICAL INFORMATION

This smoker is equipped with a power cord with a 3 prong grounded plug. DO NOT cut or remove the grounding prong from the smoker power cord or from any extension cord used with the smoker.

The smoker should only be plugged into a 120 VAC, 15 amp, grounded receptacle.

Use only a 3 prong grounded extension cord rated for outdoor use marked with a “w” (formerly w-A). This designation indicates the cord is rated for outdoor use and includes sunlight resistant jacket and wet location rated conductors.

MOBILE SMOKER WARNINGS

GENERAL

1. Mobile smokers are intended for outdoor use. NEVER use in a garage, building, shed, breezeway or other enclosed area. The mobile smoker shall not be used under any overhead combustible construction.
2. Store your smoker in a well-ventilated area. If stored indoors, detach and leave LP cylinders outdoors in a well-ventilated area away from heat and away from where children may tamper with them.
3. Keep the electrical supply cord and the fuel supply hose away from any heated surfaces.
4. Do not remove service compartment access panels when smoker is in operation or leave off during operation.
5. After a period of storage or nonuse, check the smoker for gas leaks and burner obstructions before use.
6. Wheel chocks must be used when the smoker is sitting stationary.
7. Level the smoker, both front to back and side to side, before operating the smoker.

OPERATION

MOBILE SMOKER WARNINGS (continued)

ELECTRICAL

1. To protect against electrical shock:
 - a) do not immerse any part of the power cord, plug or extension cord in water or any other liquid.
 - b) use only a 3 prong extension cord, and only plug into a 15 amp grounded receptacle.
2. Unplug the smoker from the outlet when not in use and before cleaning.
3. Do not let the extension cord hang over the edge of a table or touch hot surfaces. Keep the cord out of walkways to avoid a tripping hazard.
4. Do not use this smoker for purposes other than intended.
5. Do not operate this smoker with a damaged cord, plug, or after the smoker malfunctions or has been damaged in any manner.

LP GAS

1. The LP cylinders must be constructed and marked in accordance with the specifications for LP gas cylinders by the U.S. Department of Transportation (DOT), or CAN/CSA B339.
2. The handling, storage and transportation of gas cylinders must be in accordance with storage and handling of Liquid Petroleum Gases, ANSI/NFPA 58 or Natural Gas and Propane Installation Code, CSA B149.1.
3. Never use a cylinder with a damaged valve. A dented or rusty LP cylinder may be hazardous and should be avoided. If in doubt, have the cylinder checked by your LP supplier. Always check for leaks after every LP cylinder change.
4. Always shut off the LP gas supply at the cylinder when the smoker is not in use.
5. Cylinders must be stored outdoors in a well-ventilated area out of the reach of children. If your smoker is stored indoors, the LP cylinder must be removed and stored outside. LP gas cylinders are not to be stored in any compartment on the smoker that is not intended for cylinder storage. Such unauthorized storage could lead to an explosion, fire, or personal injury.
6. Cylinders should not be allowed to remain in a high heat area such as a closed car, trunk, or in direct sunlight.

OPERATION

MOBILE SMOKER WARNINGS (continued)

LP GAS (continued)

7. Before each use, inspect the gas hose. If excessive abrasion, wear or if the hose is cut it must be replaced prior to the smoker being put into operation.
8. LEAK TESTING: Do not use a flame to check for a gas leak. To prevent fire or explosion hazard, DO NOT smoke or allow any potential source of ignition (sparks, electrical arcing, etc.) in the area while performing a leak test. Leak tests should be conducted outdoors only.
 - a. Create a soapy solution of 1 part soap and 1 part water, or use a gas leak detector solution available for purchase from a plumbing supply or hardware store. Confirm that all control knobs are in the off position.
 - b. Open the gas supply valves and apply the soap solution generously by paint brush or squirt bottle on all connections and fittings. If bubbles appear to “grow” on any of the connections, you have a gas leak, immediately turn off the gas supply.
9. Fixing a gas leak: Wash off the soapy solution with cold water and dry. Tighten the loose joint, or replace the faulty part with manufacturer-recommended replacement parts.
10. Do not attempt to repair the LP cylinder valve if it is damaged. The only way to safely resolve a damaged cylinder is to replace it.
11. Repeat the leak test to ensure that no leaks are present.
12. Do not operate the smoker if there is a gas leak present.
13. Leaking gas may cause a fire or explosion which can cause serious bodily injury or death.
14. When not in use, the gas valve on the LP tanks must be turned off and the supply line disconnected from the tanks. The protective dust cap must be installed on the valve outlet.
15. Liquid propane is not natural gas. The conversion to or attempted use of natural gas in a liquid propane smoker is dangerous and will void your warranty.
16. Do not attempt to disconnect any gas fitting while your smoker is in operation.
17. Although your liquid propane cylinder may appear to be empty, gas may still be present. The cylinder should be transported and stored with the valve closed.

MAINTENANCE



WARNING

It is extremely important to follow the below maintenance procedures. Grease or solids buildup inside the smoker could result in a fire hazard.



WARNING:

Before any service is performed on the smoker, the gas supply should be turned off and the power disconnected.

DAILY:

1. Remove all product racks from smoker and take to sink area for cleaning. Use a commercial foodservice detergent/degreaser. Follow the product manufacturer's instructions for proper use, cautions and warnings. Protective gear such as goggles and rubber gloves should be used.
2. Sanitize product racks with a commercial product service sanitizer. Follow the product manufacturer's instructions for proper use, cautions and warnings. Protective gear such as goggles and rubber gloves should be used.
3. Empty/drain the grease after each cook cycle. Refer to the Grease Removal Instructions on page 19 of this manual.
4. Remove ashes and coals from firebox after each cook cycle. Refer to the Ash Removal Instructions on page 18 of this manual.

WEEKLY:

1. The flue shall be inspected weekly for the following conditions in accordance with NFPA® 96:
 - a. Residue that might begin to restrict the vent or create an additional fuel source. The flue or chimney should be cleaned before these conditions exist.
 - b. Corrosion or physical damage that might reduce the flue's capacity to contain effluent. The flue or chimney shall be repaired or replaced if any unsafe condition is evident.
2. The combustion chamber shall be scraped clean to its original surface once each week and shall be inspected for deterioration or defects.
3. Inspect the burner head for accumulation of ashes. If ashes are present, clean immediately. Ashes in the burner head can cause the burner to misfire.
4. Inspect the product door and firebox door gaskets.

Replace if damaged or leaking.

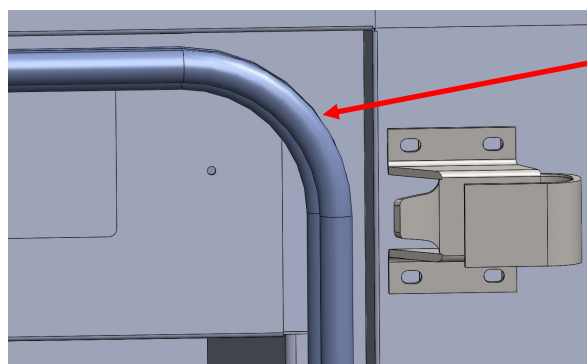

Product door gasket

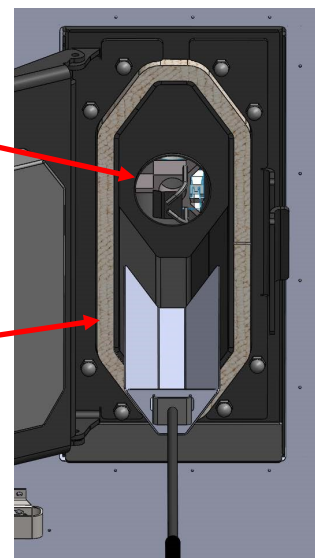

Burner head

Firebox gasket

MAINTENANCE

MONTHLY:

1. Inspect the blower wheel for solids or creosote buildup or an out-of-balance condition. Clean as needed. Remove and clean the rack slides and air channels.

WARNING: Solids buildup will cause the blower wheel to be out of balance and, if not cleaned, can cause damage to the blower wheel and to the convection fan motor.

WARNING: Smoker MUST be off and power disconnected before opening service door.

Removing the thumb screw and inspection cover allows for inspection of the blower wheel.



To remove the rack slides, air channels and blower wheel for cleaning:

- a. Remove the rack slides on both sides of the smoker (and center on the SRG-800) by lifting up and out.
- b. Remove the air channels on both sides of the smoker (and center on the SRG-800) by lifting up and out.
- c. Remove the 1/4-20 bolts that secure the blower wheel shroud to the smoker.
- d. Carefully lower the shroud away from the blower wheel and out of the smoker.

NOTE: If there is not a lot of buildup on the blower wheel, it can be carefully cleaned without removing it from the motor shaft. If a more thorough cleaning is needed, proceed to the next steps.

- e. Insert a 5/32" Allen wrench through the access holes in the blower wheel to loosen the set screws.
- f. Remove the retaining ring on the end of convection motor shaft.

To re-install repeat the above steps in reverse order. Be sure to tighten the blower wheel set screw against the flat portion of the convection motor shaft. When re-installing the air channels, the sections with the smaller holes should go to the bottom (SRG400 only).

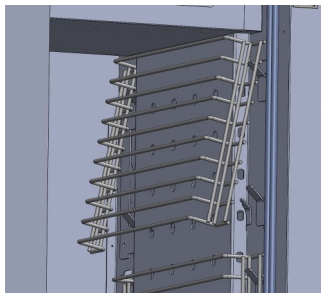

a.

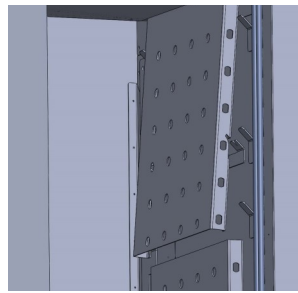

b.

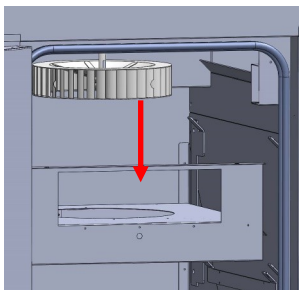

d.

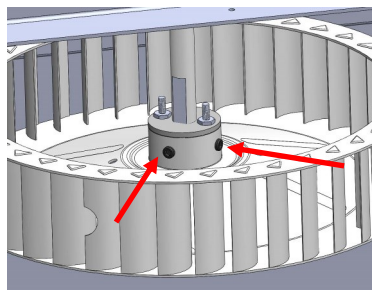

e.

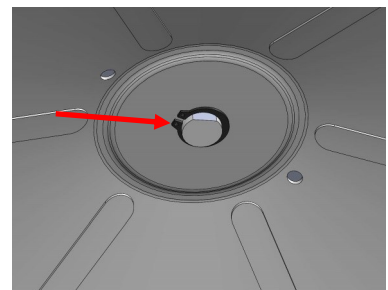

f.

MAINTENANCE

MONTHLY (continued):

2. Check the thermostat thermocouple. Be sure there is no solids or creosote buildup. Clean as needed.

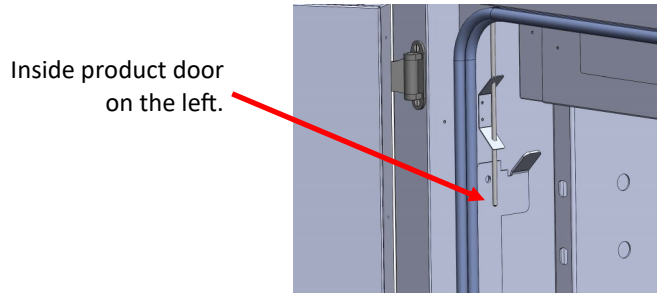

3. Check the product door hinges and the product door latches. Tighten screws and align as needed.

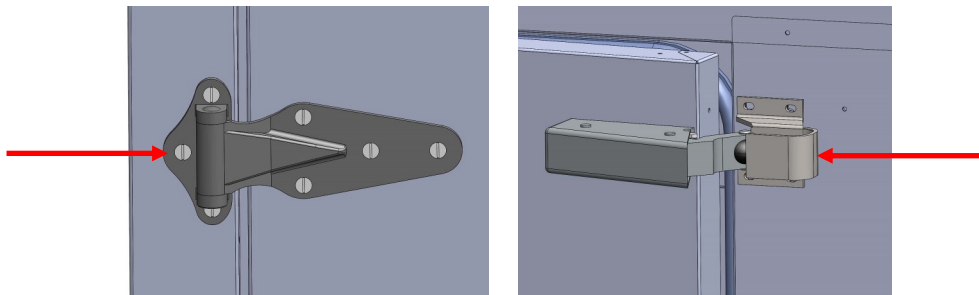

QUARTERLY:

1. At least quarterly, the baffle board should be removed, and the creosote scrapped off of the firebox side of the baffle board, along with the interior of the smoker around the firebox. The top portion of the baffle board (red highlighted area) stays in the smoker, while the bottom portion (green highlighted area) is removed.

SRG-400: Before removing the bottom portion, the top, right, back wire rack slide hanger (blue highlighted area) must be removed from the interior liner of the smoker and the baffle board.

SRG-800: The horizontal top air channels on each side of the blower wheel shroud should be removed and the creosote cleaned.

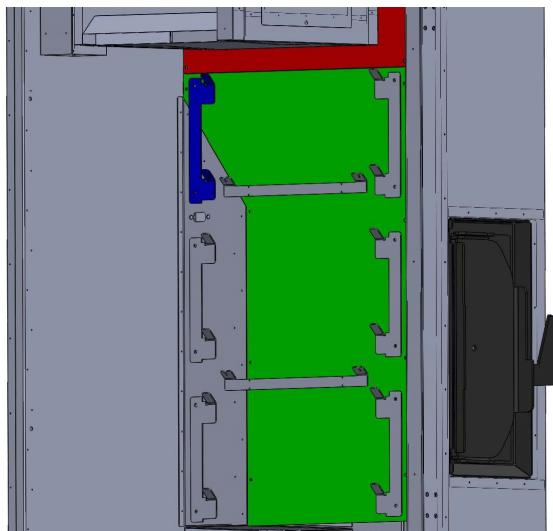

SRG-400
Shown



MAINTENANCE

QUARTERLY (continued):

PRODUCT DOOR LATCHES:



CAUTION:

The latch rollers are spring-loaded and will open quickly with a lot of force.
Do not pinch a finger or hand.

Remove and clean the product door latches.

1. After the smoker has been turned off and given time to cool, open the product door leaving the roller in the open position.
2. Using a crescent wrench on the edge of the latch cover, apply force to the crescent wrench towards the smoker to pop the latch cover free, and then the latch can be lifted away from the backing plate.
3. TO RE-INSTALL: Position the door latch, with the roller in the up position, over the backing plate, fastening the hooks on the latch over the tabs on the backing plate. Using the palm of your hand, push the bottom of the latch into the backing plate until it locks in position.

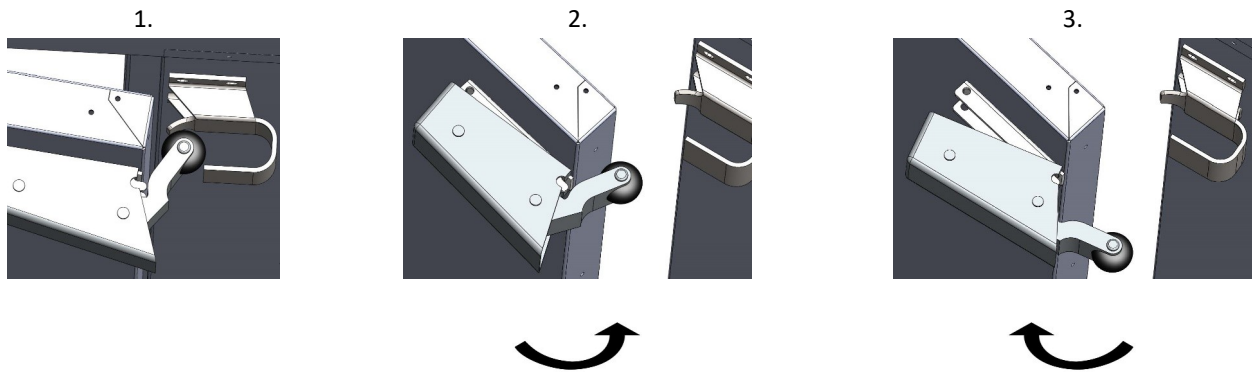

SEMI - ANNUALLY:

1. Have an experienced service technician inspect and clean the burner electrode. Southern Pride recommends replacing the burner electrode every 12-18 months, depending on usage.

MAINTENANCE

AS NEEDED:

(Frequency will depend on usage and local health department's requirements):



WARNING

It is extremely important to follow the below maintenance procedures. Grease or solids buildup inside the smoker could result in a fire hazard.

INTERIOR:

- Use a commercial product service detergent/degreaser to clean the smoker interior. Follow the product manufacturer's instructions for proper use, cautions and warnings. Protective gear such as goggles and rubber gloves should be used. **Note: Avoid the use of abrasive cleaning compounds, chloride based cleaners, or cleaners containing quaternary salts. Never use hydrochloric acid (muriatic acid) on stainless steel.**
- Smoker should be cool. Do not try to put cleaner on smoker when hot.
- While product racks are out of the smoker apply cleaner to the smoker interior: walls, ceiling, and floor and allow to soak for 10 minutes.
- Thoroughly rinse smoker interior with water using a water hose or pressure washer. **(Do not directly pressure wash the convection blower wheel; the blower wheel should be removed for cleaning).**
- Drain waste water; place a container under the drain. Dispose of rinse water according to local environmental requirements.
- Inspect the interior of the smoker for any areas that did not come clean; repeat the cleaning procedure in those areas.
- Thoroughly rinse the interior of the smoker and drain.
- Sanitize the smoker interior: walls, ceiling, floor, and convection fan with a commercial product service sanitizer. Follow the product manufacturer's instructions for proper use, cautions and warnings. Protective gear such as goggles and rubber gloves should be used. Wet all surfaces using a cloth or sprayer. Allow to remain wet for 10 minutes.
- Rinse surfaces by wiping with a cloth and clean warm water, and dry with a clean, soft cloth.
- To dry interior of the smoker leave product door open and allow to air dry.

Note: Consult with the appropriate state or local health department regarding all applicable cleaning and sanitation requirements for equipment.

MAINTENANCE

AS NEEDED:

(Frequency will depend on usage and local health department's requirements):

STAINLESS STEEL SURFACES:

Use non-abrasive cleaning products for use on stainless steel surfaces. Cleaning agents must be chloride-free compounds and must not contain quaternary salts. Never use hydrochloric acid (muriatic acid) on stainless steel surfaces. Always use the proper cleaning agent at the manufacturer's recommended strength.

EXTERIOR:

Southern Pride Smokers are known for their attractive appearance. We achieve this by selecting only the finest grade of type 304 stainless steel and applying exacting workmanship.

- All of the exterior of the smoker can be cleaned with a mild soap and water solution.
- Before cleaning the smoker, make sure it is turned off, main power switch off, and power cord disconnected from power.
- On mobile smokers, turn off LP gas.
- If the smoker is HOT from use, allow adequate time for it to cool down (approximately 1 hour).
- After the smoker exterior has been washed, apply a stainless steel polish cleaner to all surfaces.
- Wipe control panel, door handles, and door gaskets thoroughly, since these areas harbor food debris.
- **Do not use scotch bright pads or scouring pads to clean the outside of your smoker. If a non-abrasive scouring pad must be used, make certain to scrub with the visible grain of the surface metal to avoid scratches.**

Caution: Some cleaning products are not suitable for stainless steel; be sure to read the label before use.

MAINTENANCE

REPLACEMENT PARTS LIST

	SRG-400 & SRG-800
Door Hinges / Closers	
Product door hinge	870003
Door closer	771001
Door closer latch	771002
Electrical	
Cook & hold control	431024
Control panel overlay	415047
Bi-metal high limit	434002
10 amp solid state relay	422006
24v transformer	425002
Cooling fan (SRG-800 only)	521001
Type "K" thermocouple	435011
Convection	
Fan motor	522009
Blower wheel	531003
Burner	
Transformer	582005
Blower motor	582008
Gas valve	582010 (Nat.) 582016 (LP)
Electrode/pilot assembly	582011 (Nat.) 582015 (LP)
High voltage lead	582012
Ignition control module	582019

	SRG-400	SRG-800
Gaskets		
Product door	070092	070104
Firebox door	071014	071016
Product Racks / Hangers		
Stainless steel rack slides	977013	977013
Nickel chrome product rack	970002	970023
Stainless steel product rack	971001	N/A

BEFORE YOU CALL FOR SERVICE



WARNING:

Before any service is performed on the smoker, the gas supply should be turned off and the power disconnected.

SYMPTOM	WHAT TO DO
Smoker does not start	<ul style="list-style-type: none"> • Check that the power cord is plugged into a live outlet. • Check that the menu is programmed and the Start/Stop button has been pressed.
Noise inside the smoker	<ul style="list-style-type: none"> • Check and clean the convection blower wheel.
BFail appears on the control	<ul style="list-style-type: none"> • Press the start/stop button until "IDLE" is displayed. • Press the start/stop button to restart the cook cycle. • If the error reappears, call a service technician to service the burner.

MAINTENANCE



WARNING:

Gas burners require an experienced technician for proper service and adjustment. If the burner does not appear to be operating properly, **DO NOT ATTEMPT TO ADJUST THE BURNER YOURSELF**, but call in a competent service technician.

TROUBLESHOOTING THE GAS BURNER

GAS BURNER SEQUENCE OF OPERATION

It is very important to know the sequence of operation when troubleshooting the burner. The below steps describe the cycle for ignition in the sequence of operation for the burner.

1. The smoker is powered on with the desired cooking temperature set.
2. At a call for heat from the thermostat, 120 volts of power go through the thermostat, the high limit switch, and on to the burner.
3. The power comes into the burner at the junction box, which is located on top of the blower motor; 120 volts AC go to the primary side of the 24 volt AC step down transformer and to the combustion motor and the combustion motor comes on.
4. The step down transformer sends 24 volts AC out to the centrifugal switch on the blower motor.
5. When the blower motor is powered up and reaches full speed, the centrifugal switch (located on the end of the motor) is activated, sending 24 volts through it and on to the ignition control module.
6. When 24 volts reaches the ignition control module, it sends a high voltage spark out to the electrode (igniter) to light the pilot flame, and at the same time, it sends 24 volts to open the pilot valve on the main gas valve.
7. After the pilot lights, the electrode (igniter) acts as a flame sensor sending a DC micro amp signal back to the control module that there is a pilot flame, then the ignition control module sends out 24 volts AC to open the main valve.
8. The pilot flame lights the flow of gas from the main valve and the burner will fire until the call for heat from the thermostat has been satisfied, shutting the burner down.

NOTE: The burner is equipped with an ignition module that has a 3-try for ignition sequence.

TROUBLESHOOTING GUIDE

SYMPTOM	WHAT TO DO
Blower motor does not run	<ul style="list-style-type: none"> • Check for 120v present at the blower motor.
Burner does not fire	<ul style="list-style-type: none"> • Check for 24 volts at the ignition control module. • Clean the centrifugal switch. • Check the condition of the ignition wire. • Clean the electrode and check the spark gap (1/8").
Burner sparks, but does not fire	<ul style="list-style-type: none"> • Remove any ash in the burner head. • Check that the gas is turned on. • Check the supply line pressure. (see page 12). • Clean the electrode.
Pilot lights, but burner does not	<ul style="list-style-type: none"> • Check for loose wire connection at the valve and control module. • Clean the igniter rod.
Pilot lights, but does not stay lit	<ul style="list-style-type: none"> • Check the igniter-sensor probe and wire.

WIRING DIAGRAM

REV6

WHITE	---
BLACK	---
PURPLE/WHITE	---
PURPLE	---
ORANGE/WHITE	---
ORANGE	---
YELLOW	---
RED/ORANGE	---
RED/PURPLE	---
RED	---
GREEN	---
BLUE	---

F=FEMALE END OF THE OVEN PLUG

15	14	13	12	11
10	9	8	7	6
5	4	3	2	1

M=MALE END OF THE CONTROL PANEL PLUG

5	4	3	2	1
10	9	8	7	6
15	14	13	12	11

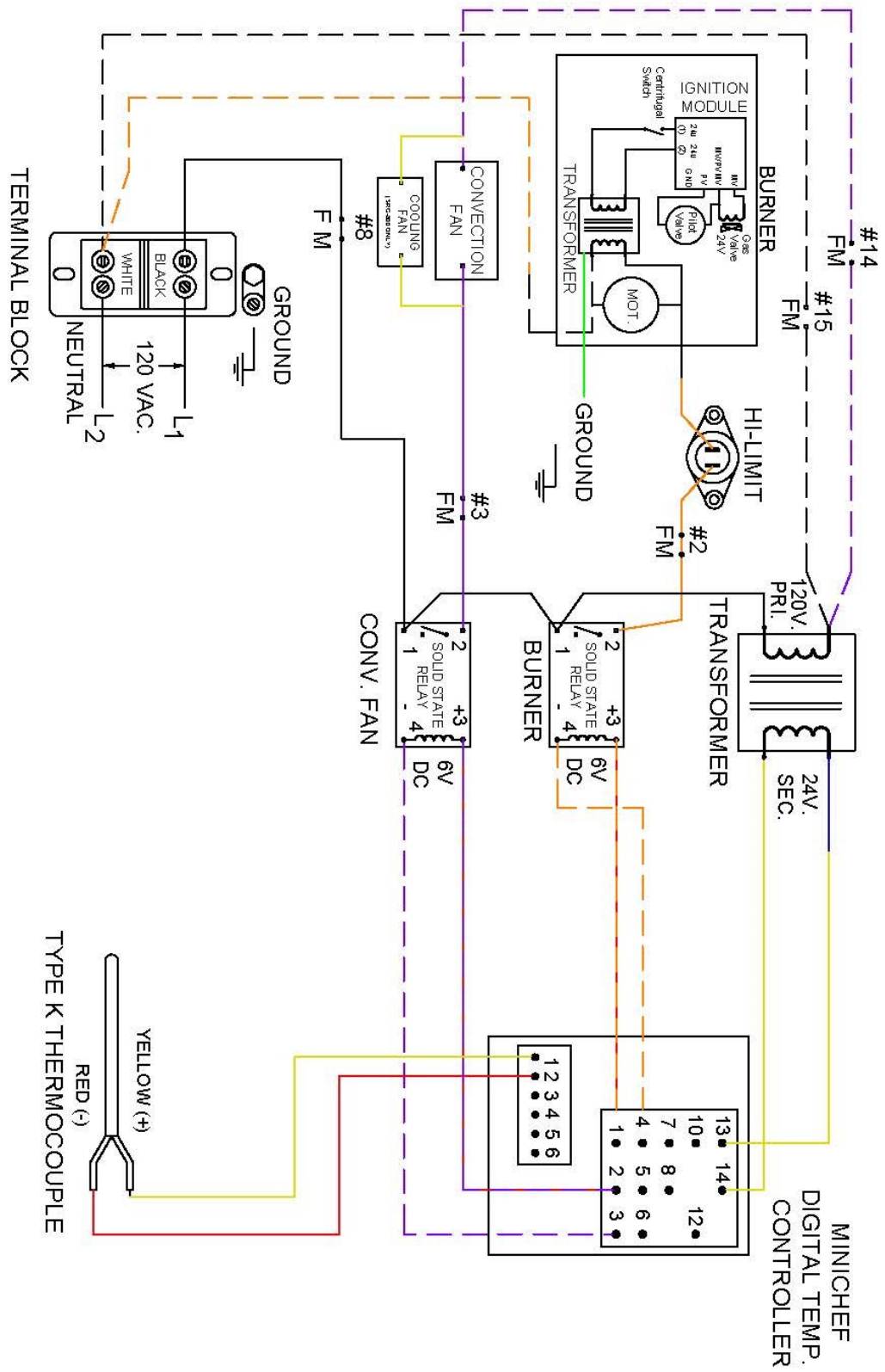

LIMITED WARRANTY

Southern Pride Distributing, LLC (“Southern Pride”) warrants to the original purchaser that any original part found to be defective in material or workmanship will, at Southern Pride’s option, subject to provisions hereinafter stated, be replaced with a new or rebuilt part. The labor warranty, provided only in the USA, remains in effect one (1) year from installation or fifteen (15) months from the shipping date, whichever occurs first. Southern Pride will bear normal labor charges performed by an authorized Southern Pride service agent during standard business hours, and excluding overtime, holiday rates or any additional fees. The parts warranty remains in effect for one (1) year from installation or fifteen (15) months from the shipping date, whichever occurs first. All warranty parts ship via standard ground delivery service.

This warranty does not cover the following:

- Improper installation, delivery or maintenance.
- Failure of the Product if it is abused, misused, or used for other than intended purpose.
- Products which are not defective or broken, or which are working as described in the Owner’s Manual.
- Damage to the Product caused by accident, fire, floods, or acts of God.
- Damage caused by services performed by unauthorized service companies.
- Service calls to correct the installation of your Product or to instruct you how to use your Product.
- Expenses for making the Product accessible for servicing.
- Replacement of consumable parts; belts, gaskets, light bulbs, etc.

NO IMPLIED WARRANTY, REPRESENTATION OR CONDITION

To the extent permitted by law, neither Southern Pride nor any company/individual affiliated with it makes any warranties, representations, conditions or promises express or implied as to the quality, performance or freedom from defect of the smokers covered by these warranties other than those set forth above, and NO STATUTORY OR IMPLIED WARRANTIES OR CONDITIONS OF MERCHANTABILITY OR APPLICABLE PERIOD OF WARRANTY SET FORTH ON THIS PAGE. THE PURCHASER’S ONLY REMEDIES IN CONNECTION WITH THE BREACH OR PERFORMANCE OF ANY WARRANTY ON THE PRODUCTS ARE THOSE SET FORTH ON THIS PAGE. IN NO EVENT WILL SOUTHERN PRIDE OR ANY COMPANY/INDIVIDUAL AFFILIATED WITH IT BE LIABLE FOR INCIDENTAL OR CONSEQUENTIAL DAMAGES. In no event shall Southern Pride be liable for loss of use, loss of revenue or profit, or loss of product, or for any indirect, incidental or consequential damages.

LIMITATION OF LIABILITY

Southern Pride will not be liable under any circumstances for any incidental, consequential or special damages, including without limitation any lost profits or labor costs, arising from the sale, use or installation of the products, from the products being incorporated into or becoming a component of another product or from any other cause whatsoever, whether based on warranty (expressed or implied) or otherwise based on contract, on tort or any other theory of liability, and regardless of any advice or representations not in writing that may have been rendered by Southern Pride concerning the sale, use or installation of the products. In the event the above warranty fails to correct purchaser’s performance problems caused by defects in workmanship and/or materials, purchaser’s exclusive remedy shall be limited to payment by Southern Pride of actual damages in an amount not to exceed the amount paid for the smoker.

IF YOU NEED SERVICE

To secure warranty service, the purchaser must (1) report the equipment defect to their authorized Southern Pride distributor and request warranty service within the applicable warranty term; (2) present evidence of the warranty start date with a valid proof of purchase; and (3) make the Product available within a reasonable time.

Should your problem not be solved to your complete satisfaction by your authorized Southern Pride distributor, you should contact Southern Pride at PO Box 354, Alamo, TN 38001, Phone: 1-800-437-2679. When contacting the manufacturer, the following information will be requested: (a) Model and serial number of the Product, (b) Address where the Product is installed, (c) Name and address of the installer and any service agency that performed service on the Product, (d) Date of original installation and dates any service work was performed, (e) Details of the problems as you can best describe them, (f) List of people, with dates, who have been contacted regarding your problem.