

**HISTORY INFORMATION FOR THE FOLLOWING MANUAL:**

# *SERVICE MANUAL (COMMON)*

GN4TR CHASSIS

Segment : CU

**ORIGINAL MANUAL ISSUE DATE: 1/2018**

<b>Version</b>	<b>Date</b>	<b>Subject</b>
1	1/2018	1st Issue
2	2/2018	Add G* BOARD HANDLING ( TOC page , pg 98 )
3	2/2018	Update Section 7 – G* BOARD HANDLING ( pg 98 )
4	3/2018	1. Update Section 7 - G* BOARD HANDLING add 'X' mark ( pg 101 ) 2. Update T/shooting Flow 4.0 No Picture ( pg 44 )

**LCD TV**  
**SONY®**

9-888-742-04

For SM - Unique , please refer :

9-888-742-Ax ( America )

9-888-742-Cx ( China )

9-888-742-Ex ( Europe )

9-888-742-Px (Asia)

# *SERVICE MANUAL (COMMON)*

---

GN4TR CHASSIS

Segment : CU

LCD TV

**SONY**<sup>®</sup>

# MODEL LIST

THIS SERVICE MANUAL CONTAINS COMMON INFORMATION FOR BELOW REGIONS AND MODELS:

## REGION

ASIA

AMERICA

EUROPE

CHINA

## MODEL

KD-49X9\*F

KD-55X9\*F

KD-65X9\*F

KD-75X9\*F

KD-85X9\*F

KD-49XF9\*

KD-55XF9\*

KD-65XF9\*

KD-75XF9\*

XBR-85X9\*F

XBR-49X9\*F

XBR-55X9\*F

XBR-65X9\*F

XBR-75X9\*F

## TABLE OF CONTENTS

<u>Section</u>	<u>Title</u>	<u>Page</u>
1.	SAFETY NOTES	5
2.	SELF DIAGNOSTIC FUNCTION	10
3.	TROUBLE SHOOTING	13
4.	SERVICE ADJUSTMENTS	70
5.	DIAGRAMS	80
6.	PANEL HANDLING	89
7.	G* BOARD HANDLING	98

Please refer Service Manual – Unique for below information :

-Dissassy and Removal Caution

-Wire Dressing

-Circuit Board Location

-Exploded Views and Parts List

Note: Pictures provided in this Service Manual might have slight difference from the actual sets.

## SECTION 1 SAFETY NOTES

### 1-1. Warnings and Caution

- 1) CAUTION :These servicing instructions are for use by qualified service personnel only.
- 2) To reduce the risk of electric shock, do not perform any servicing other than that contained in the operating instructions unless you are qualified to do so.
- 3) WARNING!! : An isolation transformer should be used during any service to avoid possible shock hazard, because of live chassis. The chassis of this receiver is directly connected to the ac power line.

The replaceable fuse could be in the neutral of the mains supply. When replacing the fuse, the mains shall be disconnected for de-energize the phase conductors.

(\*Except AC ADAPTOR, Because it does not carry out replacing an internal fuse.)

4) CARRYING THE TV : Be sure to follow these guidelines to protect your property and avoid causing serious injury :

- Carry the TV with an adequate number of people; larger size TVs require two or more people.
- Correct hand placement while carrying the TV is very important for safety and to avoid damages.

5) SAFETY-RELATED COMPONENT WARNING!! : Components identified by shading and ! mark on the exploded views, and in the parts list are critical for safe operation. Replace these components with Sony parts whose part numbers appear as shown in this manual or in supplements published by Sony. Circuit adjustments that are critical for safe operation are identified in this manual. Follow these procedures whenever critical components are replaced or improper operation is suspected.

6) IMPORTANT REMINDER FOR TV MAINBOARD REPLACEMENT :

It is mandatory for service centers to confirm the TV's system information after each repair carried out with Mainboard replacement.

Whenever a TV Main board is replaced, the correct TV Model and Serial number must be reinserted into memory.

This is a MANDATORY procedure that each service center must apply.

Please refer to the chapter of ADJUSTMENT in this service manual to find out how to set the model number and serial number in service mode.

### 1-2-1. Caution Handling of LCD Panel

When repairing the LCD Panel, make sure you are grounded with a wrist band.

When repairing the LCD Panel on the wall, the panel must be secured using the 4 mounting holes on the rear cover.

- 1) Do not press the panel or frame edge to avoid the risk of electric shock.
- 2) Do not scratch or press on the panel with any sharp objects.
- 3) Do not leave the module in high temperature or in areas of high humidity for an extended period of time.
- 4) Do not expose the LCD panel to direct sunlight.
- 5) Avoid contact with water. It may cause short circuit within the module.
- 6) Disconnect the AC power when replacing the backlight (CCFL) or inverter circuit. (High voltage occurs at the inverter circuit at 650Vrms)
- 7) Always clean the LCD panel with a soft cloth material.
- 8) Use care when handling the wires or connectors of the inverter circuit. Damaging the wires may cause a short circuit.
- 9) Protect the panel from ESD to avoid damaging the electronic circuit (C-MOS).

10) During the repair, DO NOT leave the Power On or Burn-in period for more than 1 hour while the TV is face down on a cloth. Refer Figure 1 .

Figure 1.

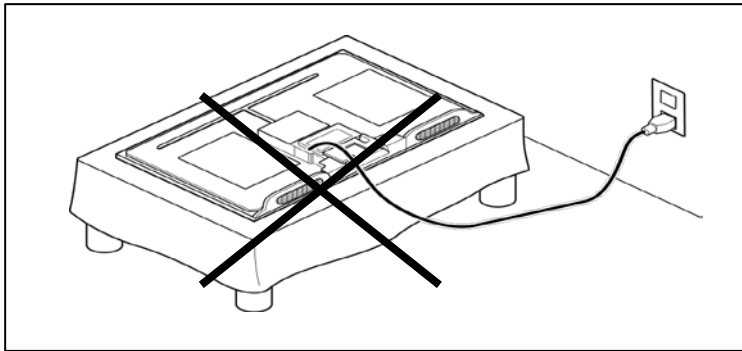

## 1-2-2. Caution for OLED Panel

### 1) Handling

When repairing the TV set, be sure you are grounded by using a wrist band.

- \*Do not press on the panel or frame edge to avoid the risk of electric shock.
- \*Do not scratch or press on the panel with any sharp objects.
- \*Do not leave the module in high temperatures or in areas of high humidity for an extended period of time.
- \*Do not expose the panel to direct sunlight.
- \*Avoid contact with water. It may cause a short circuit within the module.
- \*Disconnect the AC power when replacing.
- \*Always clean the panel with a soft cloth material.
- \*Use care when handling the wires or connectors. Damaging the wires may cause a short.
- \*Protect the panel from ESD to avoid damaging the electronic circuit.

\*Do not recommend power-on in the conditions which laid face down the panel, in repair activity. Refer Figure 1 .

\*When transporting by hand, do not put stress on the panel and the frame around the screen.

Refer to the panel handling chapter of each Service manual, or the "Transporting" information of the Reference Guide of each model for how to hold it.

### 2) OLED Screen

- Although the OLED screen is made with high-precision technology and 99.99% or more of the pixels are effective, black dots may appear or bright points of light (white, red, blue, or green) may appear constantly on the OLED screen. This is a structural property of the OLED screen and is not a malfunction.
- Do not push or scratch the front filter, or place objects on top of this TV set. The image may be uneven or the OLED screen may be damaged.
- The screen and cabinet get warm when this TV set is in use. This is not a malfunction.

### 3) Precautions to Protect the Screen from Damage

#### Image retention

OLED TV's are susceptible to image retention (burn-in) due to the characteristics of the materials used. Image retention may occur if images are displayed in the same location on the screen repeatedly or over extended periods of time. This is not a malfunction of the TV. Avoid displaying images that may cause image retention.

**The following are examples of images that may cause image retention:**

- Content with black bars either on the top and bottom and/or the left and right sides of the screen. (for example, Letterboxed, 4:3 screen, Standard definition)
- Static images such as photos.
- Video games that might have static content in some part of the screen.
- On-screen menus, program guides, channel logos etc.
- Static content from applications.
- On-screen tickers, such as those used for news and headlines.

**To reduce the risk of image retention:**

- Fill the screen by changing [Wide mode] to eliminate the black bars. Select [Wide mode] other than [Normal].
- Turn off the OSD (On Screen Display) by pressing the DISPLAY button, and turn off the menus from connected equipment. For details, refer to the instruction manuals for the connected equipment.
- Avoid displaying static images with bright colours (including white), clocks or logos on any portion of the screen.
- Set the picture settings based on the ambient conditions. The Standard Picture is recommended for home use and when viewing content that often displays the station logos, etc.

The TV has following features to help reduce/ prevent image retention. Press the HOME button, then select [Settings] – [Picture & Display] – [Expert panel settings] – the desired option.

**Panel refresh**

Panel refresh will automatically run to adjust the uniformity of the TV screen after it has been in use for long periods of time.

Panel refresh can also be performed manually and should only be used if image retention is very noticeable or you see the following message: [Panel refresh did not finish...]

Caution:

- The Panel refresh function may affect the panel. As a reference, perform the Panel refresh only once a year, do not perform it more than once a year as it may affect the usable life of the panel.
- Panel refresh takes about one hour to complete.
- A white line may be displayed on the screen during the Panel refresh, this is not a malfunction of the TV.
- Panel refresh will only work when the room temperature is between 10 °C and 40 °C.

**Pixel shift**

Automatically moves the image on the screen to prevent image retention.

**Other feature**

The screen brightness is automatically reduced when displaying still images, clocks, bright colours or logos etc.

**IMPORTANT REMINDER FOR OLED PANEL REPLACEMENT**

When carrying out OLED panel replacement, it is mandatory of a service center to confirm and record Panel ON time & Panel Refresh times.

It is because they are indispensable information in order to clarify responsibility for image retention after panel replacement.

Please refer to the chapter of SELF DIAGNOSIS FUNCTION in this service manual to find out how to confirm the Panel ON time & Panel Refresh times in service mode.

**1-3. Caution About the Lithium Battery**

- 1) Danger of explosion if battery is incorrectly replaced. Replace only with the same or equivalent type.
- 2) Outer case broken battery should not contact to water.

**1-4. Safety Check-Out**

After correcting the original service problem, perform the following safety checks before releasing the set to the customer:-

- 1) Check the area of your repair for unsoldered or poorly soldered connections. Check the entire board surface for solder splashes and bridges.
- 2) Check the inter board wiring to ensure that no wires are pinched or contact high-wattage resistors.
- 3) Check all control knobs, shields, covers, ground straps and mounting hardware have been replaced. Be absolutely certain you have replaced all the insulators.

- 4) Look for unauthorized replacement parts, particularly transistors that were installed during a previous repair. Point them out to the customer and recommend their replacement.
- 5) Look for parts which, though functioning show obvious signs of deterioration. Point them out to the customer and recommend their replacement.
- 6) Check the line cords for cracks and abrasion. Recommend the replacement of any such line cord to the customer.
- 7) Check the antenna terminals, metal trim, metalized knobs, screws and all other exposed metal parts for AC leakage. Check leakage test as described next.
8. For safety reasons, repairing the Power board and/or Inverter board is prohibited.

### 1-5. Leakage Test

(To protect electric shock when customer touch the terminal.)

Leakage current can be measured by V: Voltmeter or oscilloscope (r.m.s. or peak reading)

Stabilized power supply instrument and isolated voltage transformer:

Use too much current capacity and isolated voltage transformer does not need to use stabilized power supply equipment.

Specification of RMS volt meter: Input resistance > 1 Mohm, Input capacitance < 200 pF, Frequency range: 15 Hz – 1MHz . Refer Figure 2.

Isolated type volt -meter (FLUKE 8921A etc \*1)

\*1 Not use FLUKE 8920A that connected to protective earth by diode

# Leakage current of measurement instrument is less than 10 $\mu$ Arms when under test equipment AC plug is opened

# Set up the following condition and turn on the set. Applied voltage:

Nominal input voltage (Description on Nameplate)

# Measure the leakage current between one phase conductor and neutral for terminal A and terminal B.

Read rms value, and then calculate to peak value PEAK VALUE = $\sqrt{2}$  RMS VALUE

Comply with the following requirement

Class II equipment (2-pin plug): for each terminal, the worst value of measurement must not exceed AC 350 $\mu$ A peak).

Note: including AC adaptor, AC adaptor/DC operated unit combination

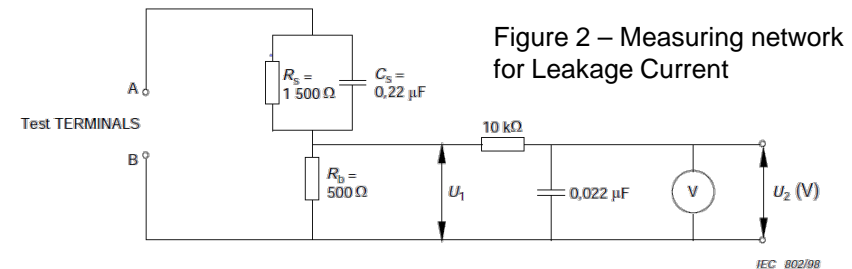

### 1-6. How to Find a Good Earth Ground

- 1) A cold-water pipe is a guaranteed earth ground; the cover-plate retaining screw on most AC outlet boxes is also at earth ground.
- 2) If the retaining screw is to be used as your earth ground, verify that it is at ground by measuring the resistance between it and a cold-water pipe with an ohmmeter. The reading should be zero ohms.
- 3) If a cold-water pipe is not accessible, connect a 60- to 100-watt trouble-light (not a neon lamp) between the hot side of the receptacle and the retaining screw. Try both slots, if necessary, to locate the hot side on the line; the lamp should light at normal brilliance if the screw is at ground potential (see Figure 3).

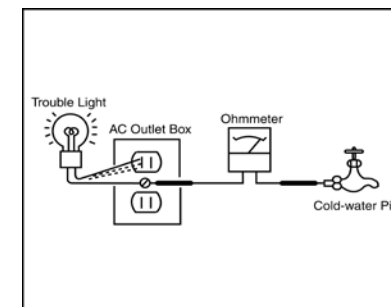

Figure 3. Checking for earth ground.

### 1-7. Lead Free Information

The circuit boards used in these models have been processed using Lead Free Solder. The boards are identified by the LF logo located close to the board designation.



Figure 4: LF Logo

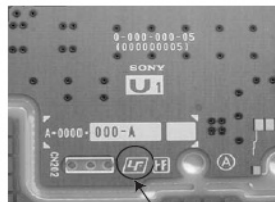

Figure 5: LF logo on circuit board

The servicing of these boards requires special precautions. It is strongly recommended to use Lead Free Solder material in order to guarantee optimal quality of new solder joints.

## SECTION 2

### SELF DIAGNOSTIC FUNCTION

The units in this manual contain a self-diagnostic function. If an error occurs, the Smart Core Red LED will automatically begin to flash.

The number of times the LED flashes translates to a probable source of the problem.

A definition of the Smart Core Red LED flash indicators is listed in the instruction manual for the user's knowledge and reference.

If an error symptom cannot be reproduced, the remote commander can be used to review the failure occurrence data stored in memory to reveal past problems and how often these problems occur.

#### DIAGNOSTIC TEST INDICATORS

When an error occurs, the Smart Core Red LED will flash a set number of times to indicate the possible cause of the problem.

If there is more than one error, the LED will identify the first of the problem areas.

Result for all of the following diagnostic items are displayed on screen.

If the screen displays a "0", no error has occurred .

#### Self Diag. Quick Reference (LED blinking)

Smart Core RED LED blinking count	Detection Items
2x	<B/G> Main 12V over voltage [MAIN_POWER]
3x	<B/G> Main 5.0V failure [DC_ALERT]
	<B/S/G> Audio amp. protection [AUD_ERR]
4x	<LD/P/B/Tu/G> LED driver failure/LED voltage protection [LD_ERR]
	<LD/P/B> <i>Error detection of the I2C communication between the Main device and the LD IC.[BCM_ERR]</i>
5x	<P/T/G/B> <i>Panel ID EEPROM I2C No ACK (Also panel power failure is a suspect) [P_ID_ERR]</i>
6x	<G/B> Backlight failure [BACKLIGHT]
7x	<B/P> Over temperature protection [TEMP_ERR]
	<B> Temp. sensor I2C No ACK [TEMP_ERR]
8x	<B> 4KBE Error (4KBE WDT)

*Blue italic*: detect at startup sequence only.

<G>: Power supply board,  
 <B>: Main board,  
 <T>: T-con board,  
 <LD>: LD board ,  
 <P>: Panel module,  
 <S>: Speaker,  
 <Tu>: Tuner board,

## Self Diag. Quick Reference (Not LED blinking [Record Only])

Error Item ( Not LED blinking [Record Only])	Detection Items
TU_DEMOD	<B/Tu> Tuner & Demodulator I2C communication failure Tuner board set detect signal monitoring
TCON ERR	<T> <i>T-CON device I2C communication failure</i>
AUD_ERR_I2C	<B> Audio amp I2C communication failure

*Blue italic*: detect at startup sequence only.

<G>: Power supply board,

<B>: Main board,

<T>: T-con board,

<LD>: LD board ,

<P>: Panel module,

<S>: Speaker,

<Tu>: Tuner board,

## Self Diagnosis Service Menu and Display

### Entry (Self Diagnosis Display)

- Go to the standby by a remote.
- Push the buttons sequentially:  
<Display><5><Vol-><Power>

### Exit

- If you want to finish service mode app, do **AC OFF/ON**  
→ \*Service mode app is disable perfectly
- if you want to move home menu, push <HOME>button  
→ \*Service mode app do background(not disable perfectly)

### Format of error timestamps

YYMMDDhhmmss (in UTC)

Example:

120823132523 -> Aug 23 2012 13:25:23 UTC

- \* Only when time is set, an error timestamp is saved.

### Panel Operation Time clear

<7> -> <0>

### Timestamps and Error Count clear

<8> -> <0>

### Total Operation Time and Boot Count clear

<9> -> <0>

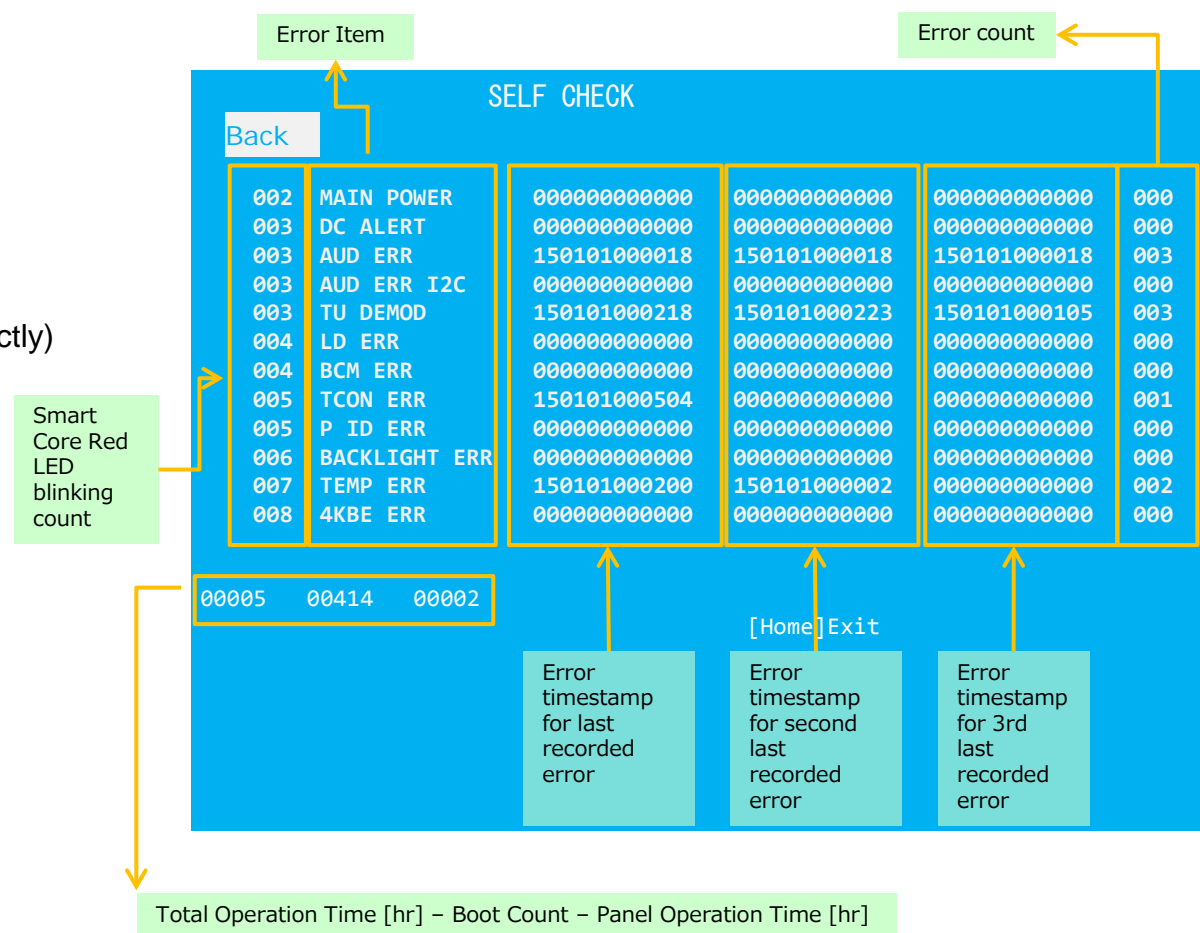

- Panel Operation Time is recorded every 30 min, but Total Operation Time is recorded every 1 hr.  
Therefore, the panel op. time might become larger than the total op. time.

## SECTION 3 TROUBLESHOOTING

### Triage Chart

#### Before you make the service call...

1. Confirm the symptom from the customer.
2. Select that symptom from the chart.
3. Bring all the boards and cables listed for that symptom.
4. Follow the troubleshooting charts in the technical guides to isolate the board.
5. Chart Colour Code

**RED DOT:** Most likely defective part

**BLUE TRIANGLE:** Secondary possible defective part

**BLACK TEXT:** Board that may correct the symptom

Reference	Symptoms - Shutdown. Power LED blinking red diagnostics sequences							Symptoms - no shutdown Error log record only					No Power	Video - missing or distorted				Remote	Network	Audio	Smart Core	Bluetooth (BT)
	2	3	4	5	6	7	8	TU_D EMOD	TCON _ERR	FRCT C_I2C	AUD_ ERR_I 2C	4KPQ _ERR _I2C	No White Power LED & does not reponse to remote (Dead Set)	Stationary colored lines or dots	No video One of Inputs	NO RF input	No video all Inputs	No Remote	Wireless can't connect	No Audio	Smart Core no LED (Set is still alive)	Bluetooth / One Step Remote (OSR) can't connect
B* Board	▲	●	▲	▲	▲	●	●	▲	▲		●		▲	▲	●	●	●	▲	▲	●	▲	▲
G* Board	●	▲	▲	▲	●								●							▲		
H* Board													▲					●		●		
Speaker		▲									▲								●			
Tuner board								●							●	▲						
Wifi & BT Module																			●			●
LD* Board			●														▲					
V By One FFC				▲					▲					▲			▲					
Tcon				●					●					▲			▲					
LCD Panel			▲	●	●									●			▲					
Problem	Power	Power	LD	Panel (Communication)	Panel (Backlight)	TEMP	4KBE															
		Audio	BCM																			

TROUBLESHOOTING Flow

1.0 No Power

**BM2A Board Model**

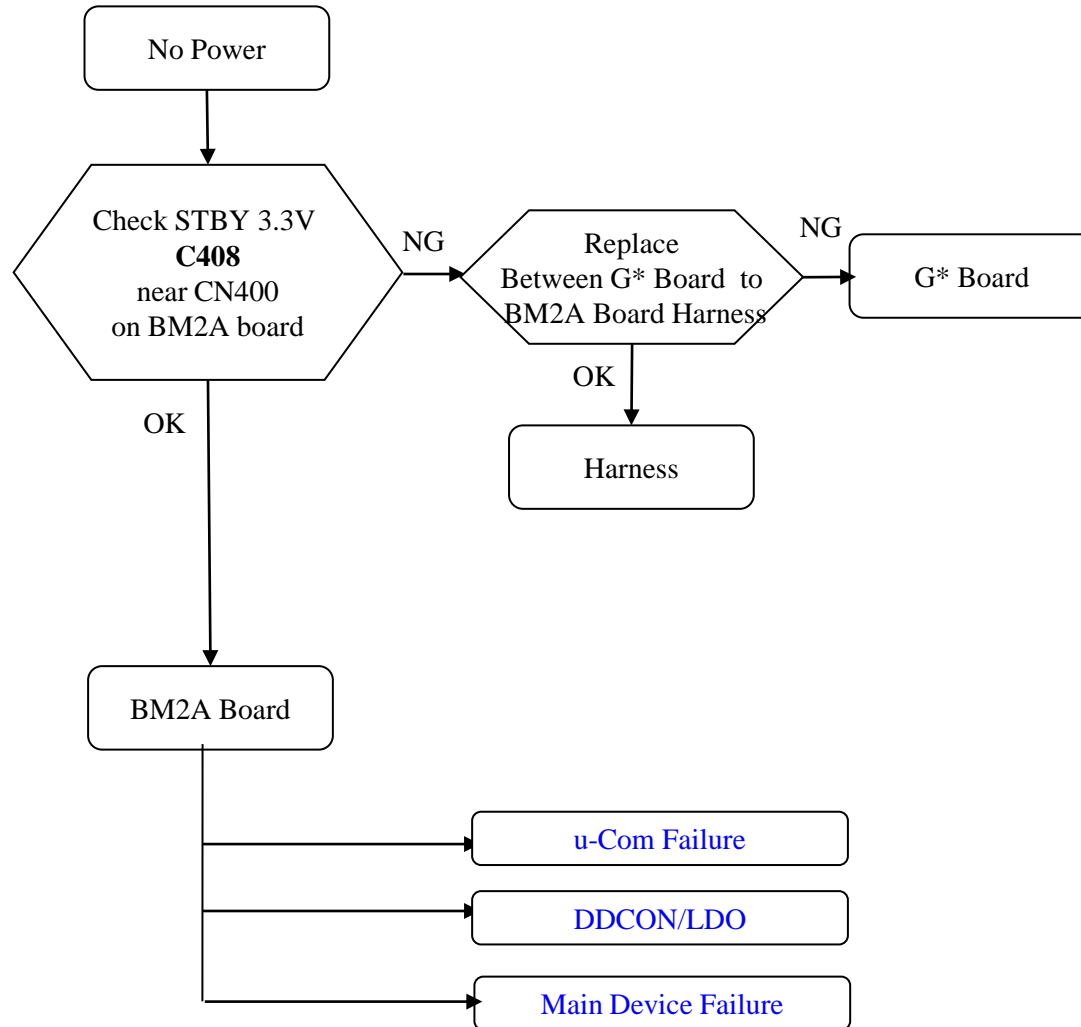

## 1.2 No Power u-com Failure

P-on u-com control signal path summary

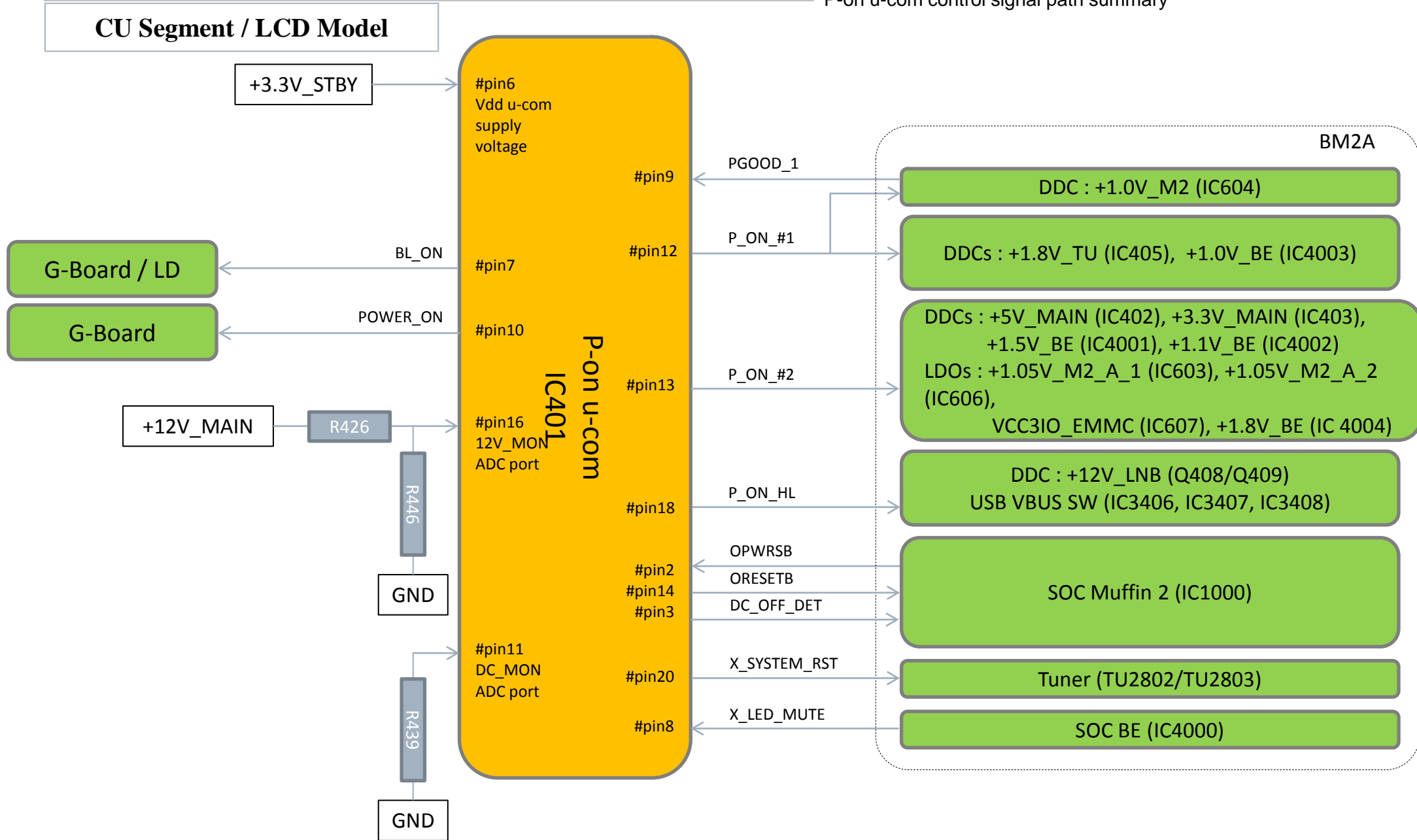

## 1.2 No Power u-com Failure

### CU Segment / LCD Model

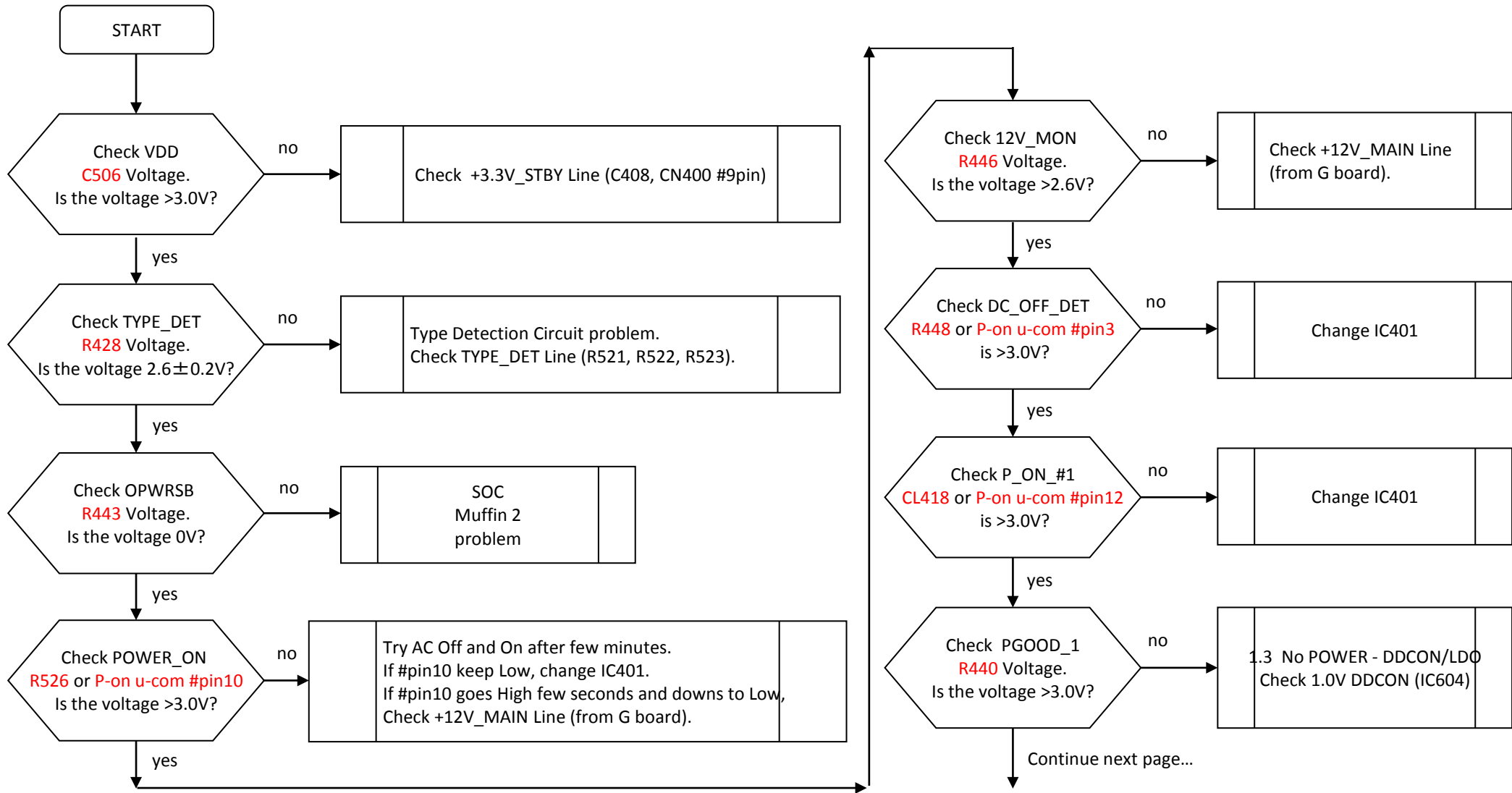

## 1.2 No Power u-com Failure

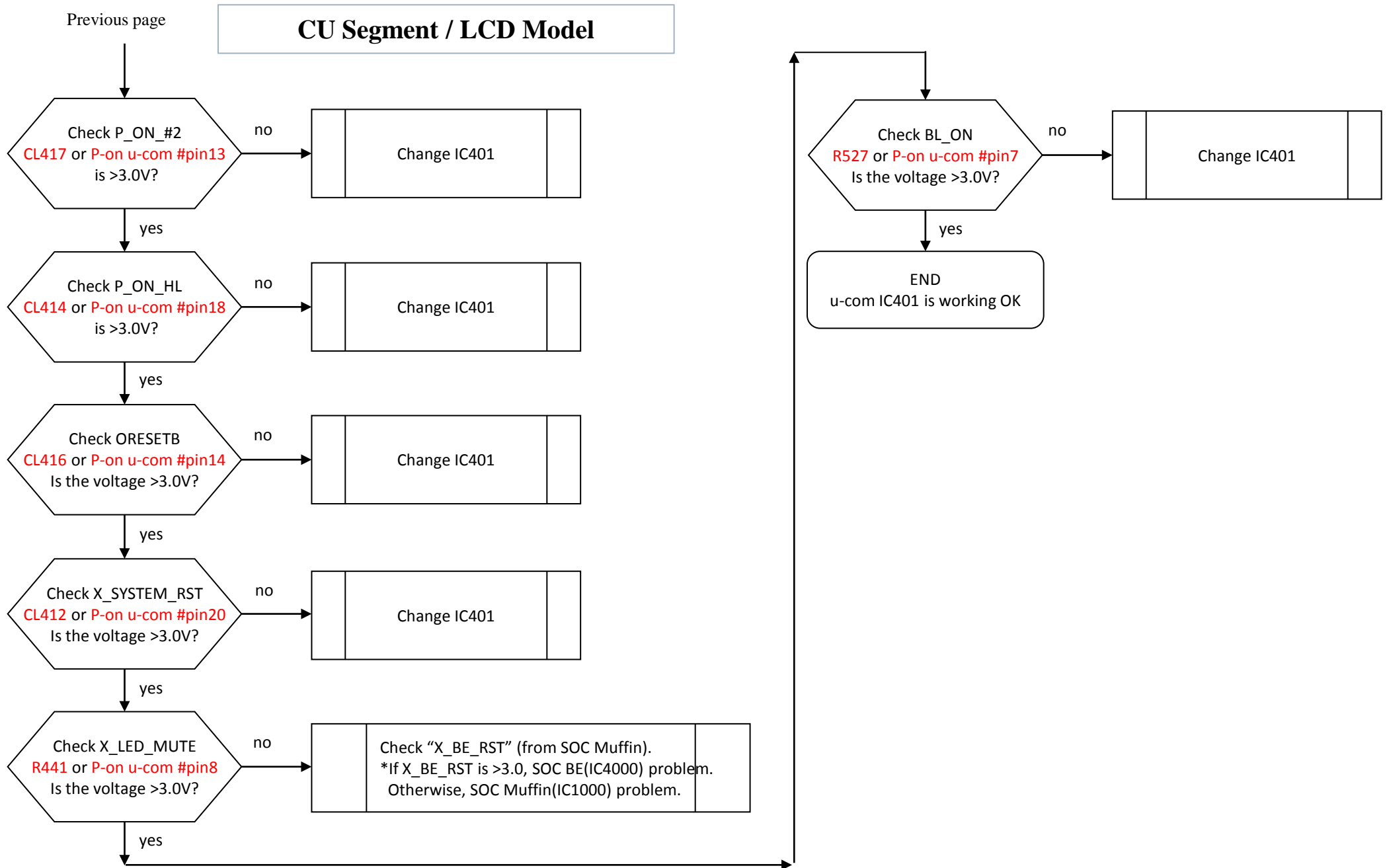

## 1.3 No Power DDCON/LDO

## Check item summary

## BM2A Board Model

Board	IC Ref	Voltage supply	Output ref.	Enable pin	Enable source	Fuse	Vcc ref.
BM2A	IC402	+5V_MAIN/+5V_AUDIO	C430	R455	P-on u-com IC401 #pin13	F400	C423
BM2A	IC403	+3.3V_MAIN/+3.3V_AUDIO	C445	R465	P-on u-com IC401 #pin13	F401	C436
BM2A	IC405	+1.8V_TU	C463	IC405 #PIN5	P-on u-com IC401 #pin12	F403	C461
BM2A	IC601	+1.5V_DDR	C609	C605	R603 (3.3V or 5V)	-	C602
BM2A	IC602	+1.05V_M2_STBY	C611	IC602 #PIN3	C610 (+3.3V _STBY)	-	C610
BM2A	IC603	+1.05V_M2_A_1	C613	IC603 #PIN3	P-on u-com IC401 #pin13	-	C612
BM2A	IC604	+1.0V_M2	C625	R623	P-on u-com IC401 #pin12	F600	C618
BM2A	IC605	+1.05V_M2_ST_ET	C631	IC605 #PIN3	M2 IC1000 #AP34	-	C630
BM2A	IC606	+1.05V_M2_A_2	C633	IC606 #PIN3	P-on u-com IC401 #pin13	-	C632
BM2A	IC607	VCC3IO_EMMC (1.8V)	C635	IC607 #PIN3	P-on u-com IC401 #pin13	-	C634
BM2A	IC4001	+1.5V_BE	C4007	IC4001 #PIN5	P-on u-com IC401 #pin13	F4000	C4005
BM2A	IC4002	+1.1V_BE	C4014	IC4002 #PIN5	P-on u-com IC401 #pin13	F4001	C4012
BM2A	IC4003	+1.0V_BE	C4027	R4020	P-on u-com IC401 #pin12	F4002	C4020
BM2A	IC4004	+1.8V_BE	C4001	IC4004 #PIN3	P-on u-com IC401 #pin13	-	C4000

### 1.3 No Power DDCON/LDO

#### DDCON check

**BM2A Board Model**

IC Ref	Voltage supply
IC601	+1.5V_DDR

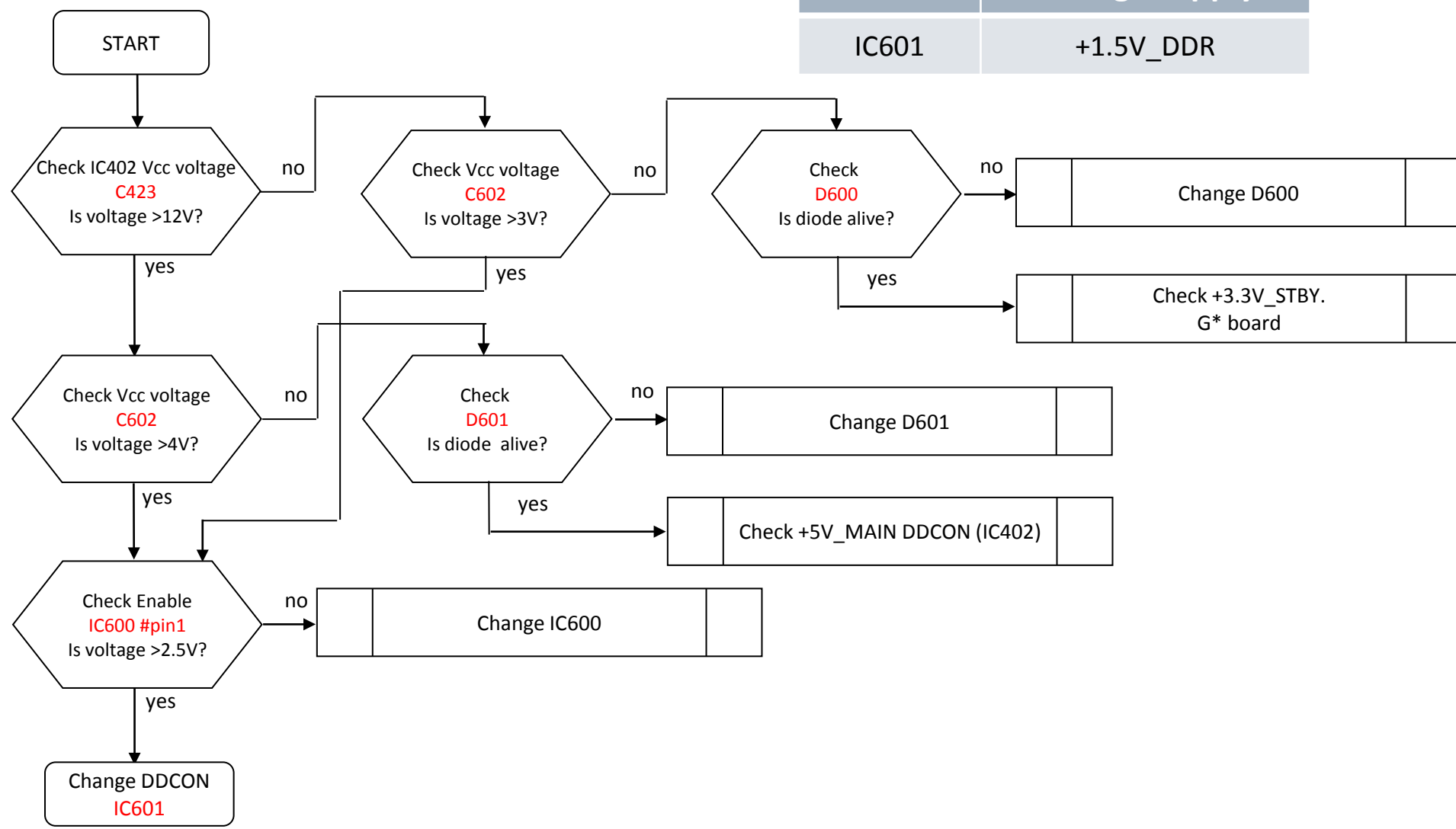

### 1.3 No Power DDCON/LDO

#### DDCONs check

IC Ref	Voltage supply
IC402	+5.0V_VBUS/+5V_MAIN
IC403	+3.3V_STBY (AC-ADP only) /+3.3V_MAIN
Q407	+3.3V_MAIN
IC405	+1.8V_TU
IC601	+1.5V_DDR
IC604	+1.0V_M2
IC4001	+1.5V_BE
IC4002	+1.1V_BE
IC4003	+1.0V_BE

**BM2A Board Model**

Please refer page-18 for Ref number.

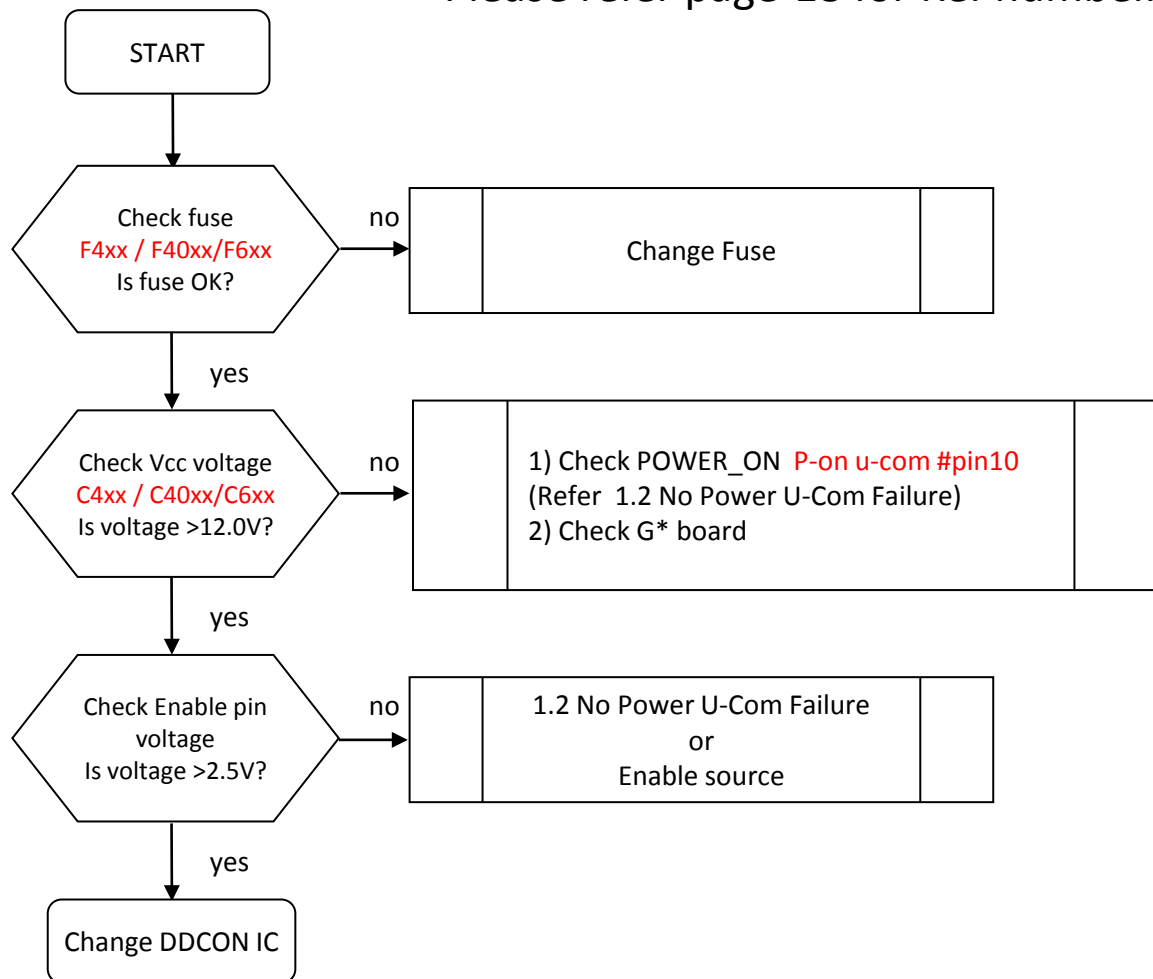

### 1.3 No Power DDCON/LDO

#### LDOs check

**BM2A Board Model**

Please refer page-18 for Ref number.

IC Ref	Voltage supply
IC602	+1.05V_M2_STBY
IC603	+1.05V_M2_A_1
IC605	+1.05V_M2_ST_ET
IC606	+1.05V_M2_A_2
IC607	VCC3IO_EMMC (1.8V)
IC4004	+1.8V_BE

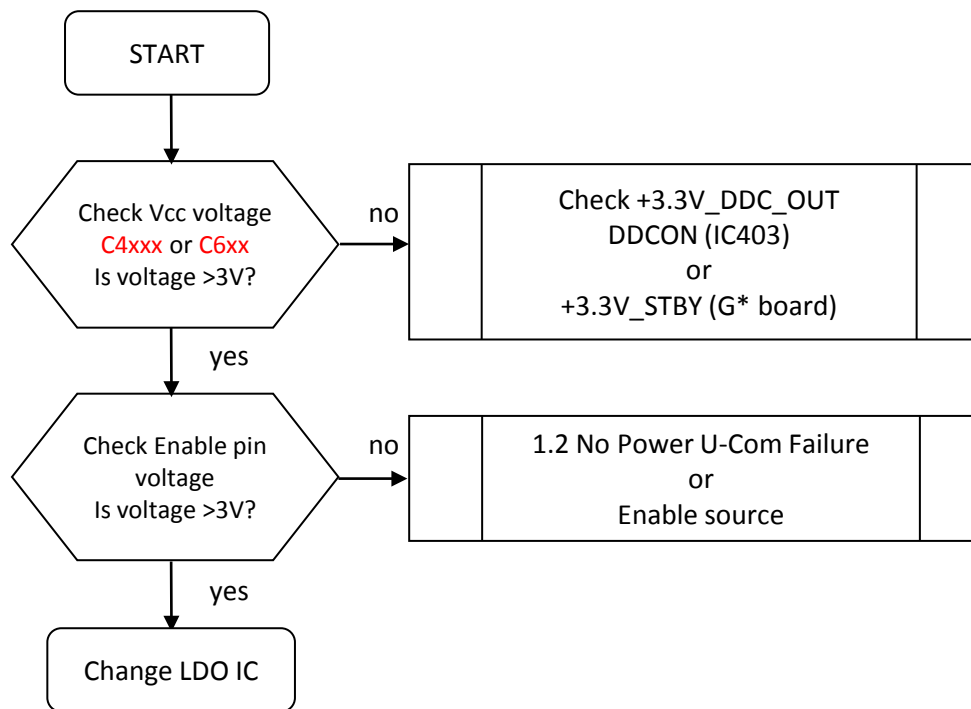

## 1.4 NO POWER – Muffin2 Failure

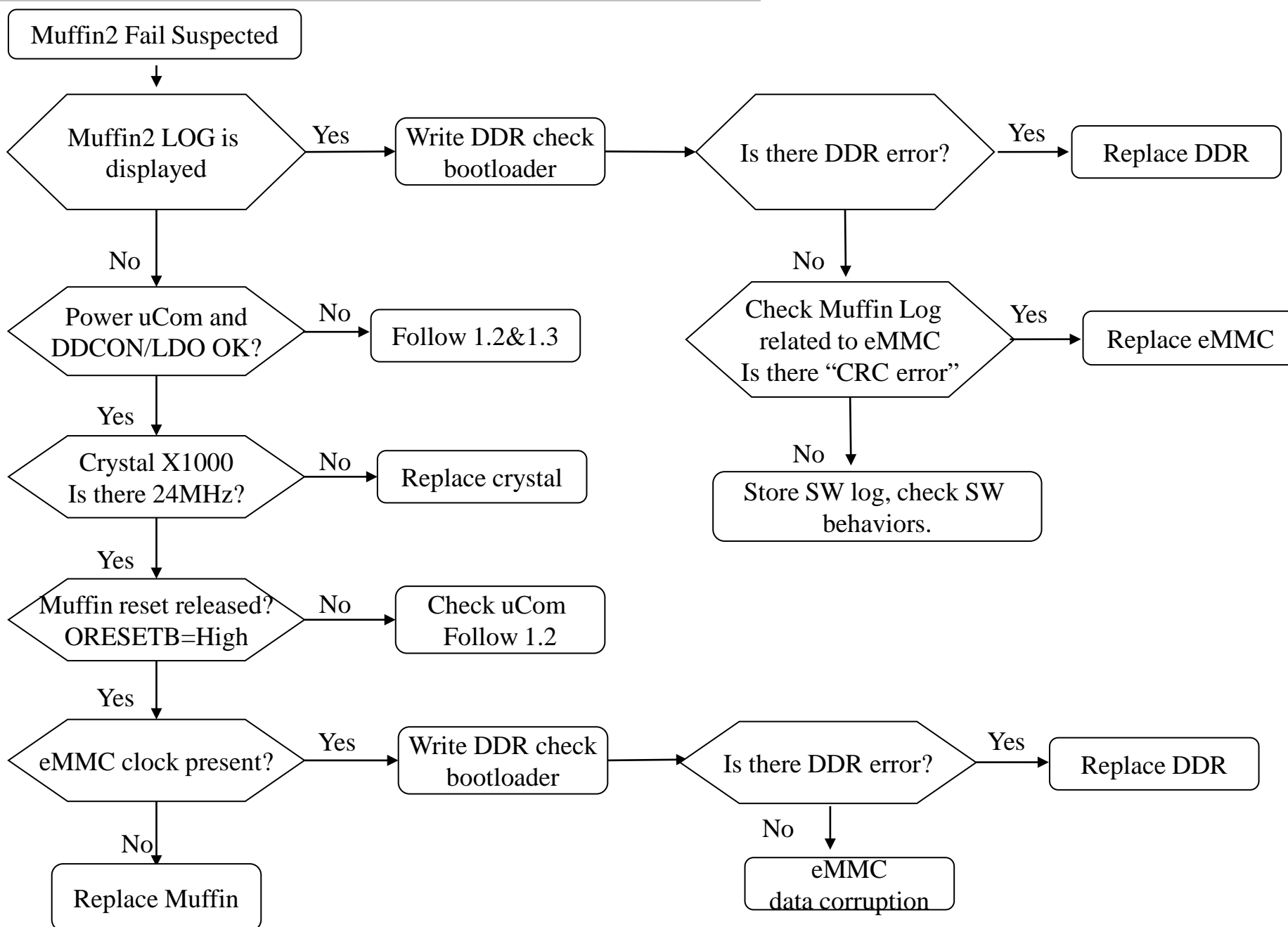

## 1.5 NO POWER – Muffin2 Replacement

---

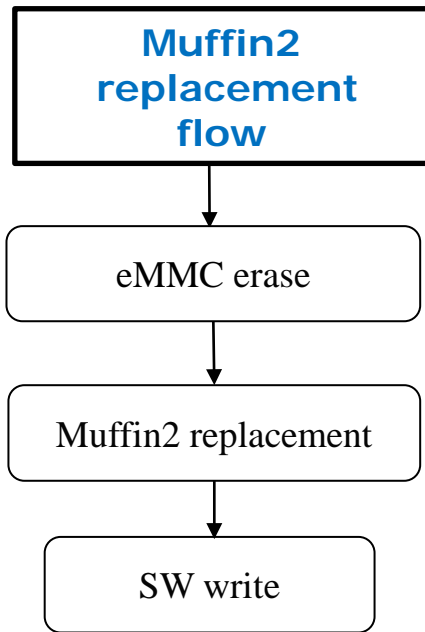

Data on eMMC need to be erase first before changing Muffin  
If cannot be erased, erase after replacing Muffin

## 2.0 LED Blinking: 2x (Main power Error)

### BM2A

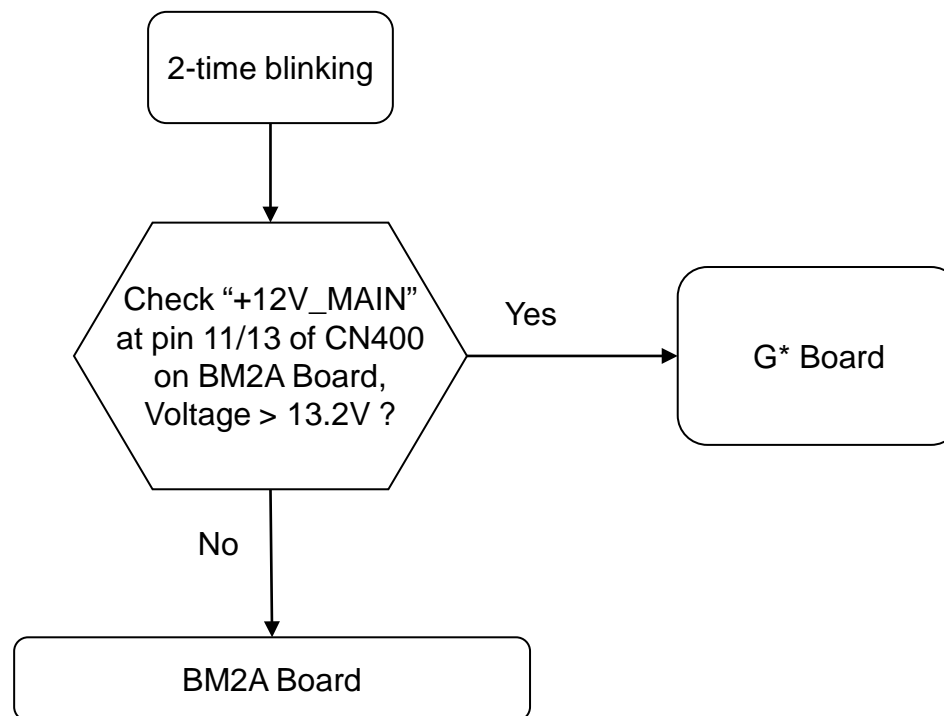

### Check point for BM2A

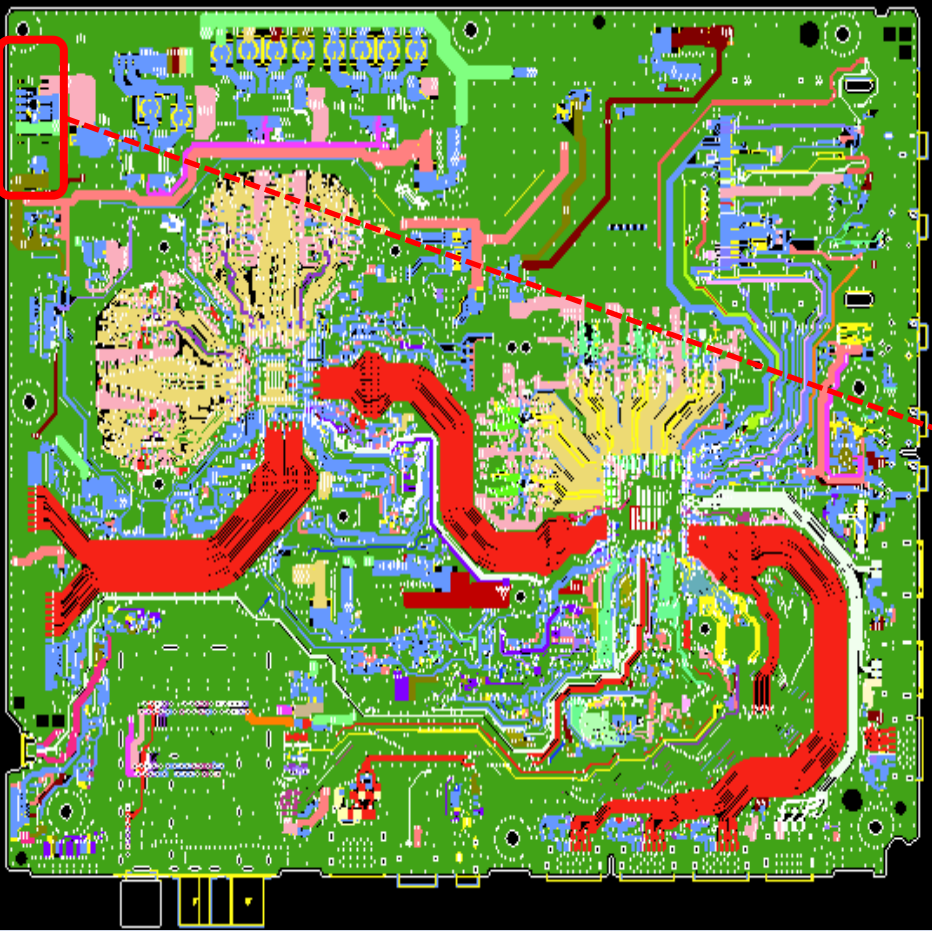
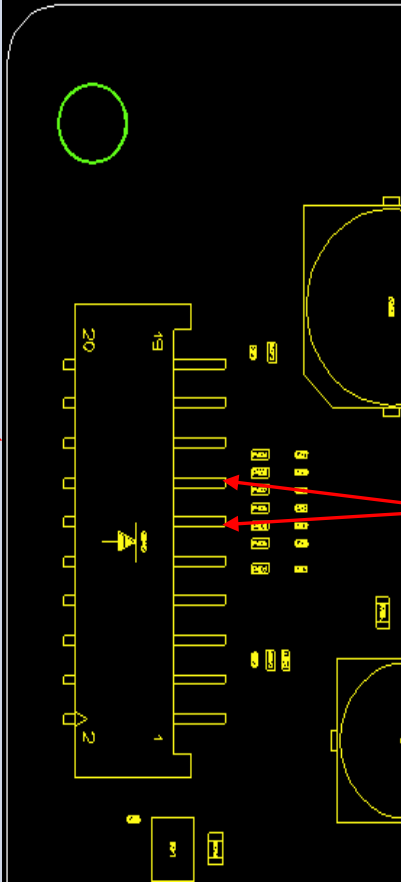
Name	Board PWB (A side)	Detail
<p>BM2A</p>		

## 2.1 LED Blinking: 3x (DC Alert Error)

## BM2A

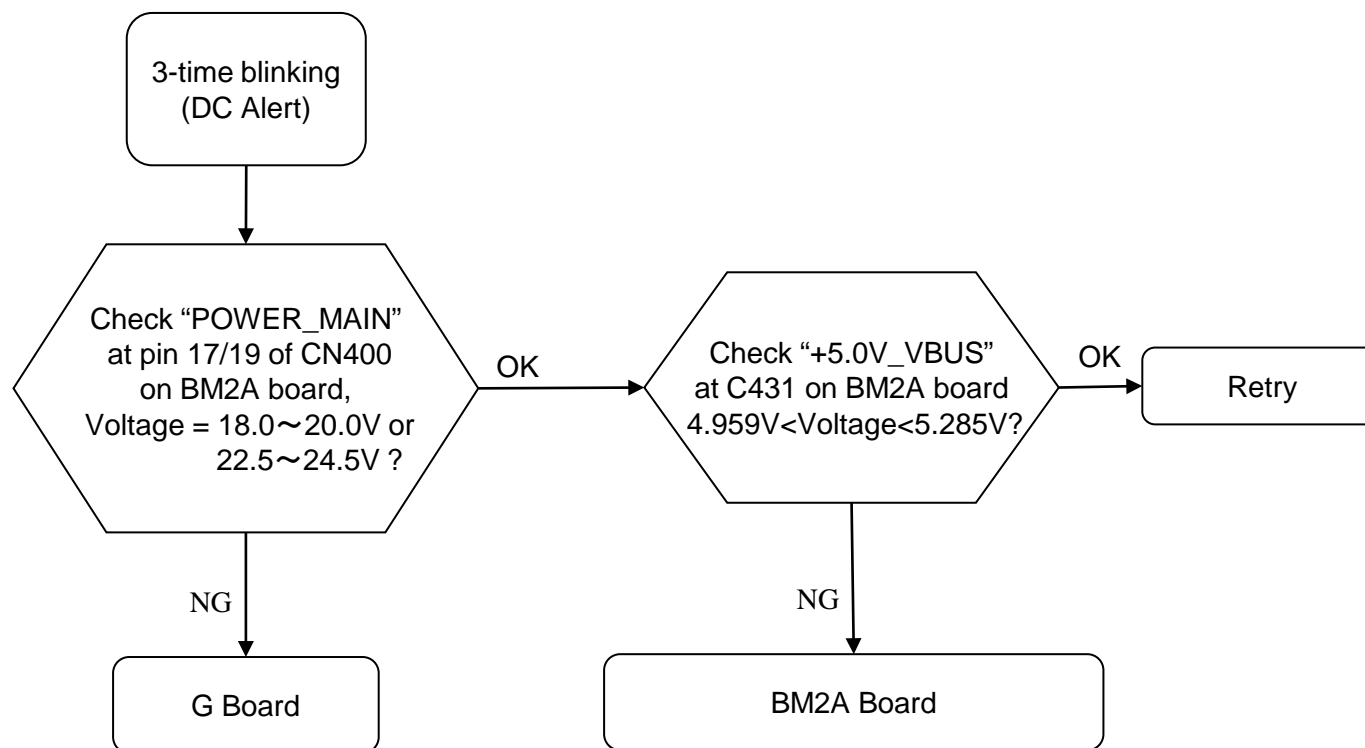

## Detail of 3x LED Blinking

	Error Item	Number of STBY LED flashing	Description
Trinity	DC_ALERT	3	Main board 5V power rail monitoring
	AUD_ERR	3	Audio amp error detection

Trinity3 Board: BM2A

Check point for BM2A

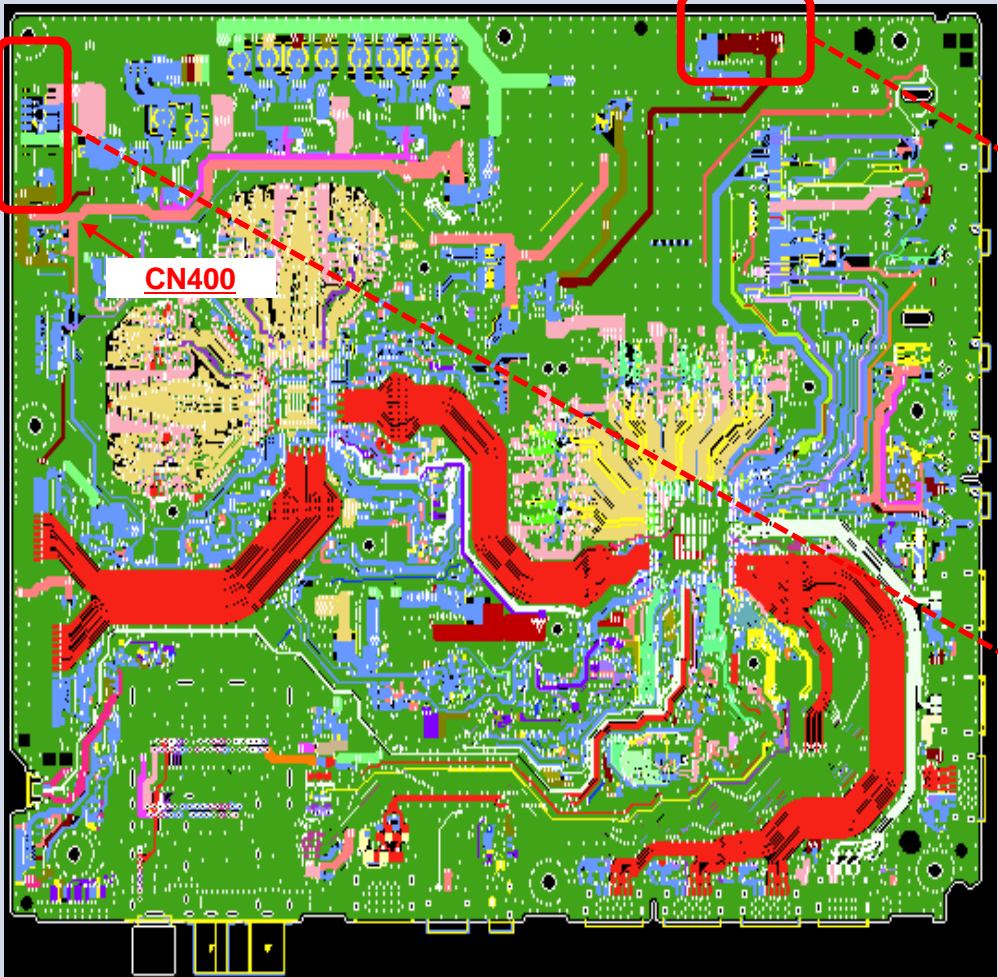
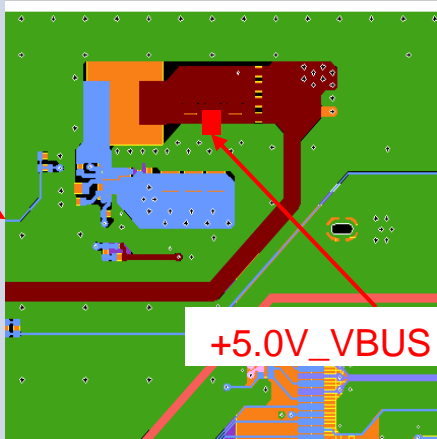
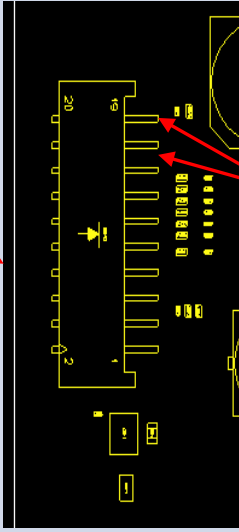
Name	Board PWB (A side)	Detail
BM2A	 <p data-bbox="510 721 609 753">CN400</p>	 <p data-bbox="1662 769 2029 801">+5.0V_VBUS at C431</p>  <p data-bbox="1751 1072 2087 1161">POWER_MAIN Pin17/19 of CN400</p>

## 2.2 LED Blinking: 3x (Audio Error)

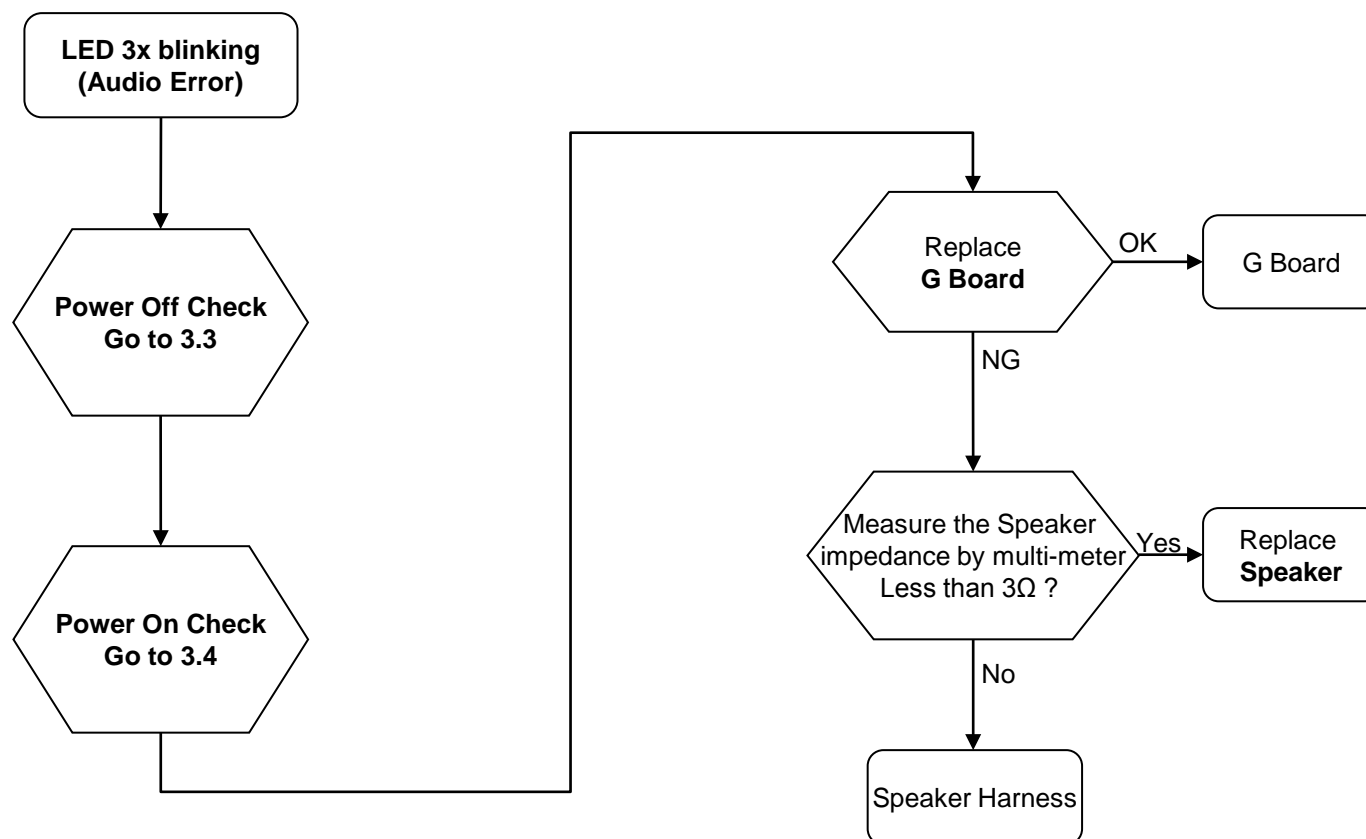

### Detail of 3x LED Blinking

	Error Item	Number of STBY LED flashing	Description
Trinity	DC_ALERT	3	Main board 5V power rail monitoring
	AUD_ERR	3	Audio amp error detection

Trinity3 Board: BM2A

## 2.3 LED BLINKING 4x (LED Voltage Error)

### BM2A

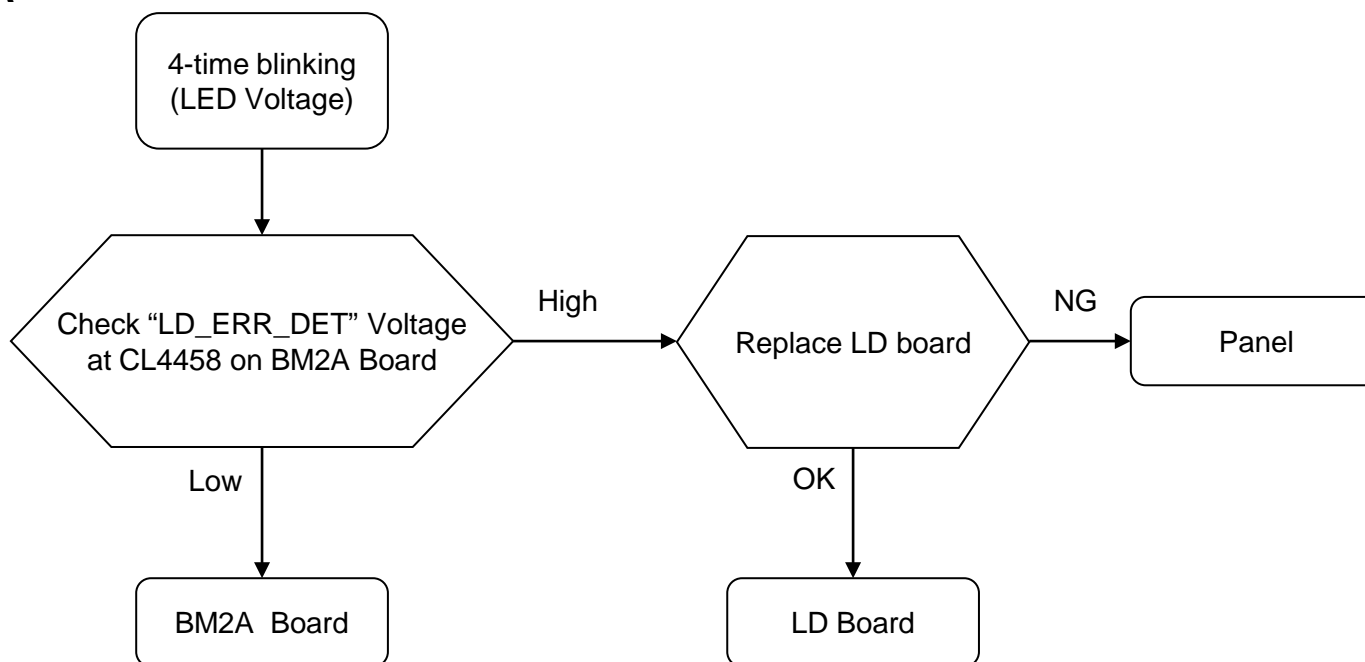

### Detail of 4x LED Blinking

	Error Item	Number of STBY LED flashing	Segment	Description
Trinity 3	LD_ERR	4	CU	LED voltage error detection with LD IC
	BCM_ERR	4	CU Only	LD IC initialize or I2C communication error detection.

Trinity3 Board: BM2A

## Check point for BM2A

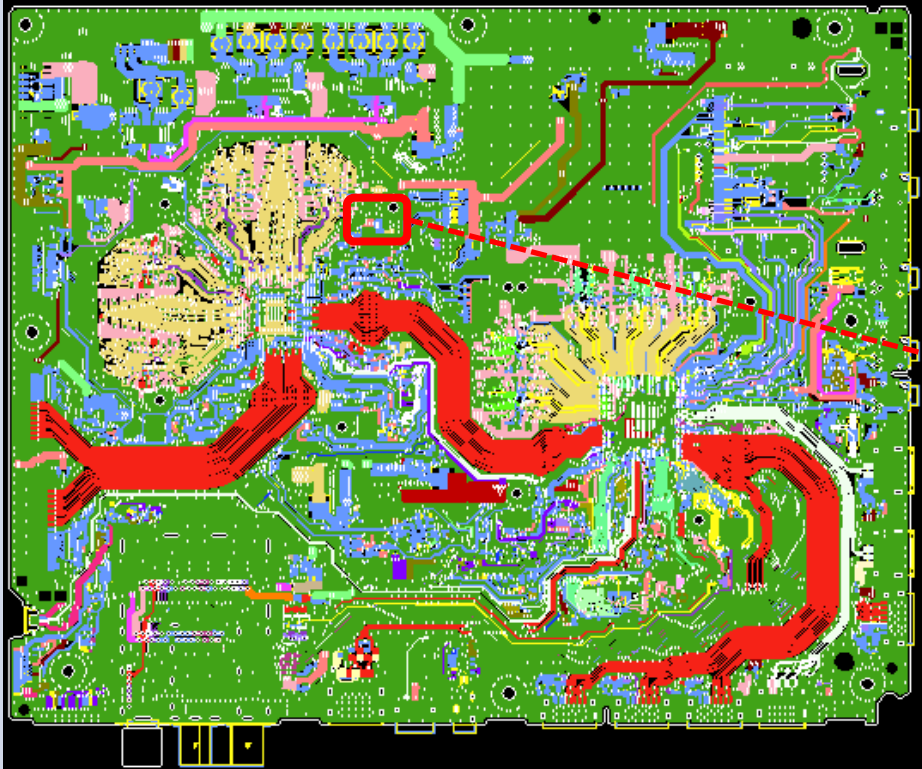
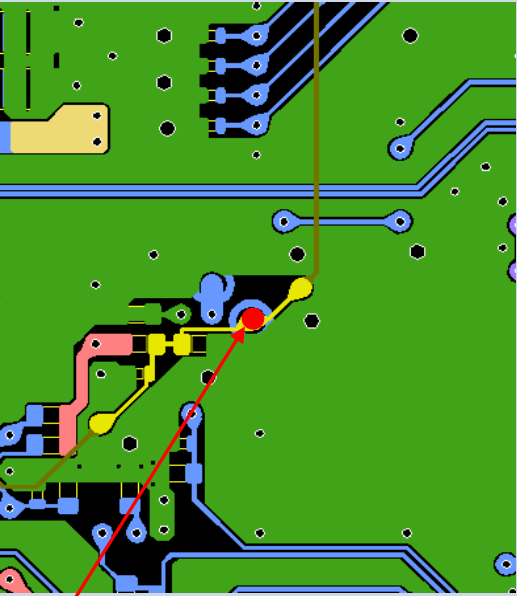
Name	Board PWB (A side)	Detail
BM2A		 <p data-bbox="1391 1262 1547 1302">CL4458</p>

## 2.4 LED BLINKING 4x (BCM Error)

### BM2A

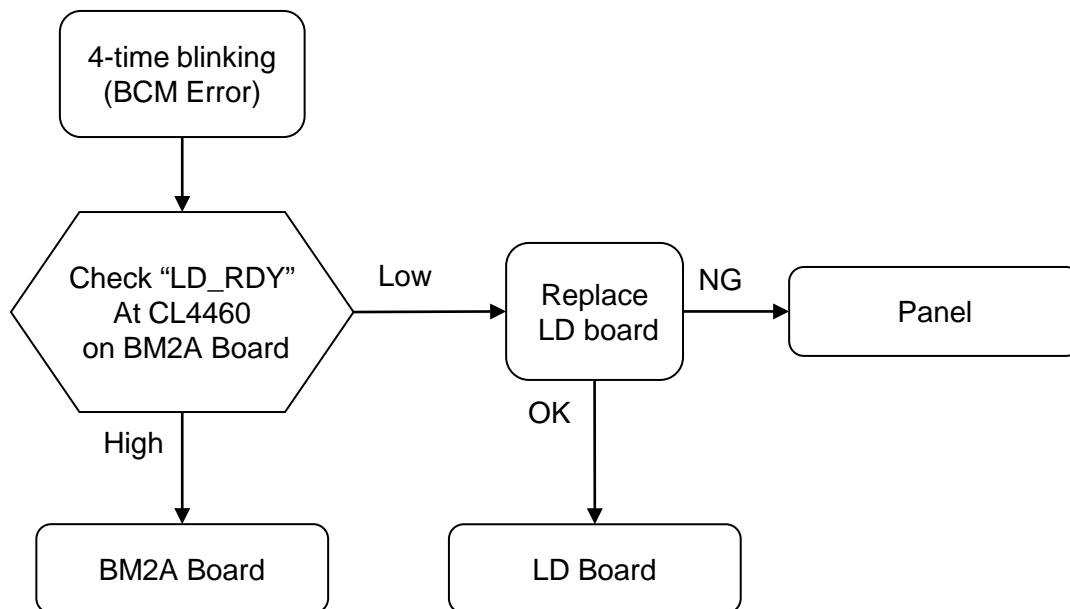

### Detail of 4x LED Blinking

	Error Item	Number of STBY LED flashing	Segment	Description
Trinity 3	LD_ERR	4	CU	LED voltage error detection with LD IC
	BCM_ERR	4	CU Only	LD IC initialize or I2C communication error detection.

Trinity3 Board: BM2A

## Check point for BM2A

Name	Board PWB (A side)	Detail
BM2A		 <p data-bbox="1794 1126 1973 1174">CL4460</p>

## 2.5 LED BLINKING: 5x (Panel ID Read Error)

### BM2A

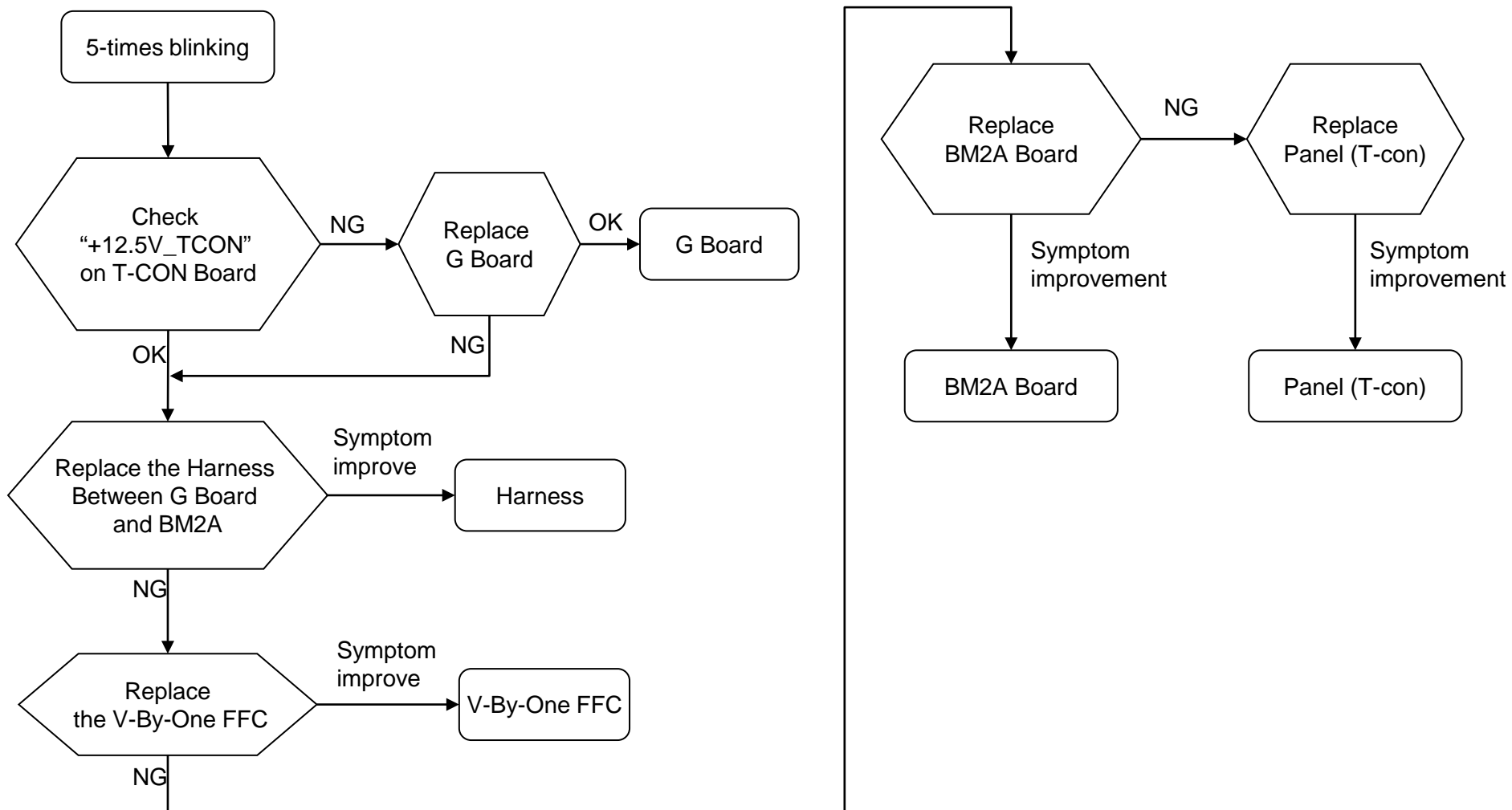

## 2.6 LED BLINKING: 6x (Backlight Error)

### BM2A

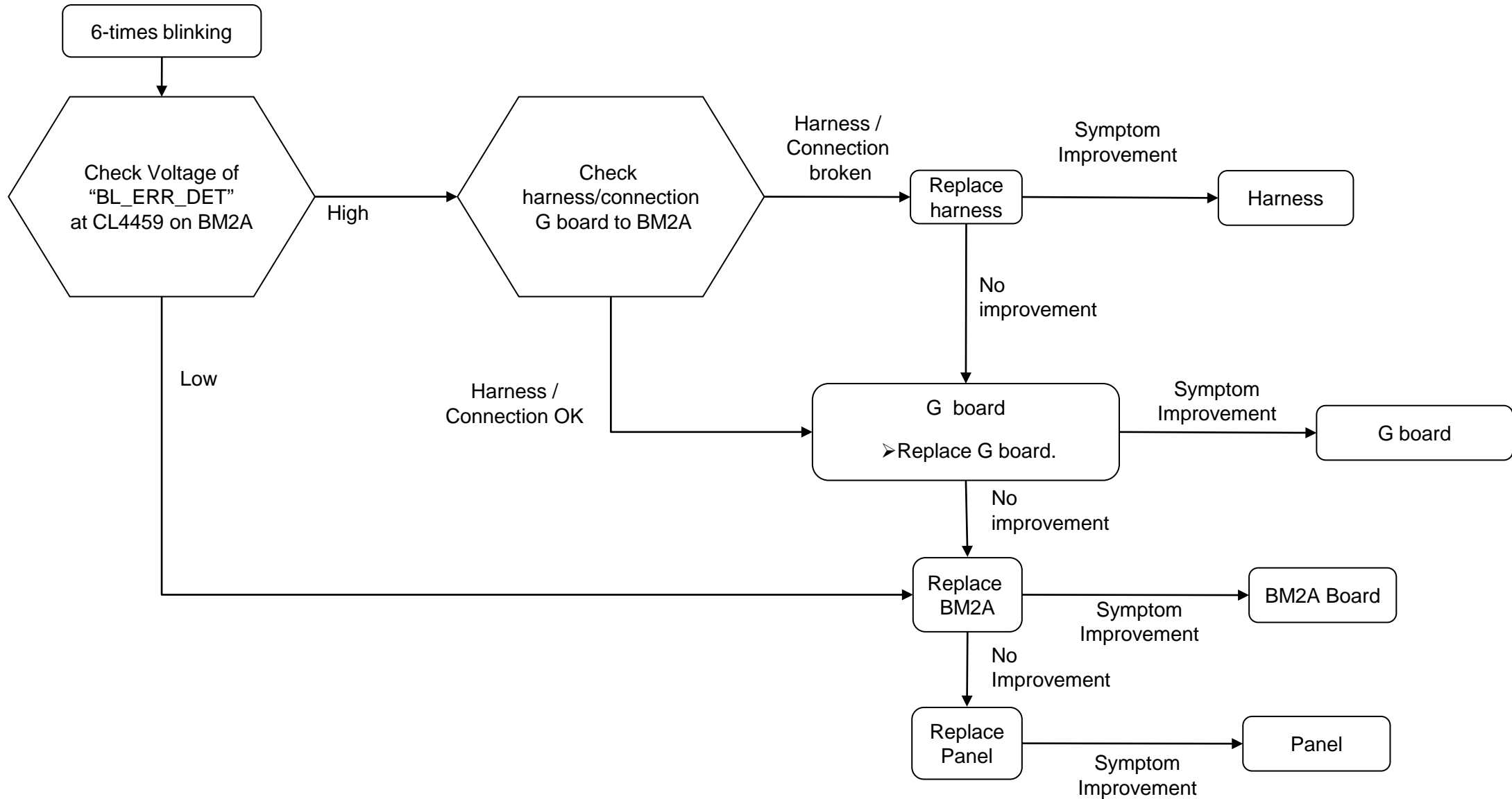

## Check point for BM2A

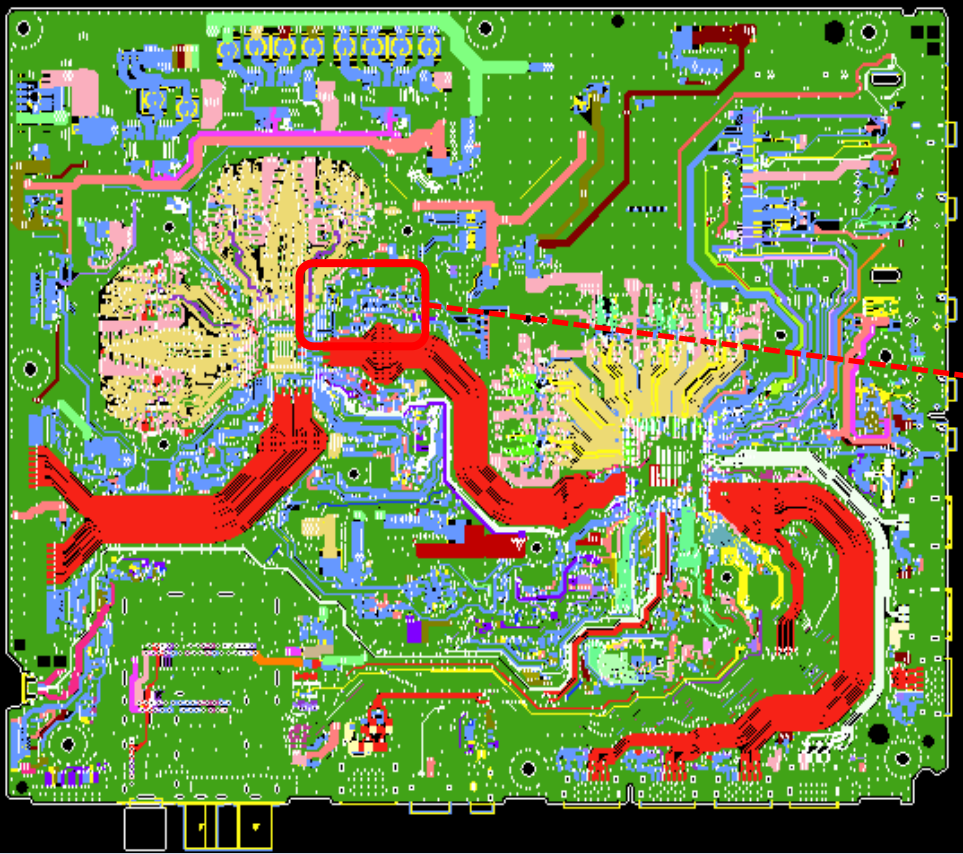
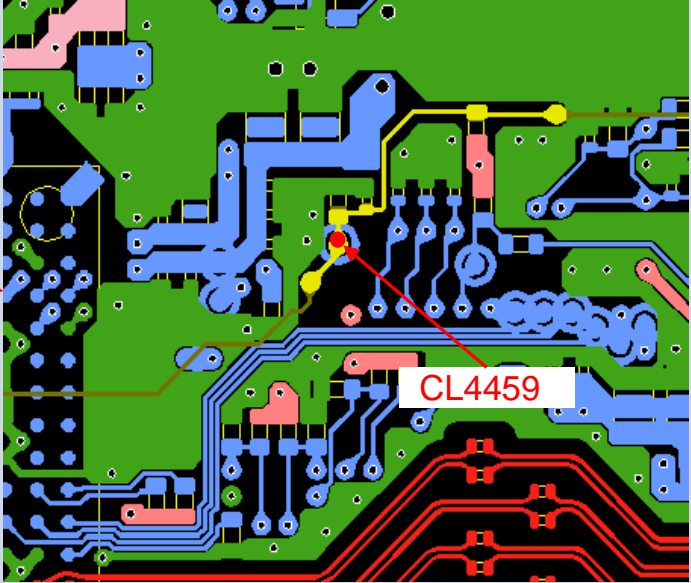
Name	Board PWB (A side)	Detail
BM2A		 <p data-bbox="1809 1007 1966 1038">CL4459</p>

## 2.7 LED BLINKING: 7x (Temperature Error)

### BM2A

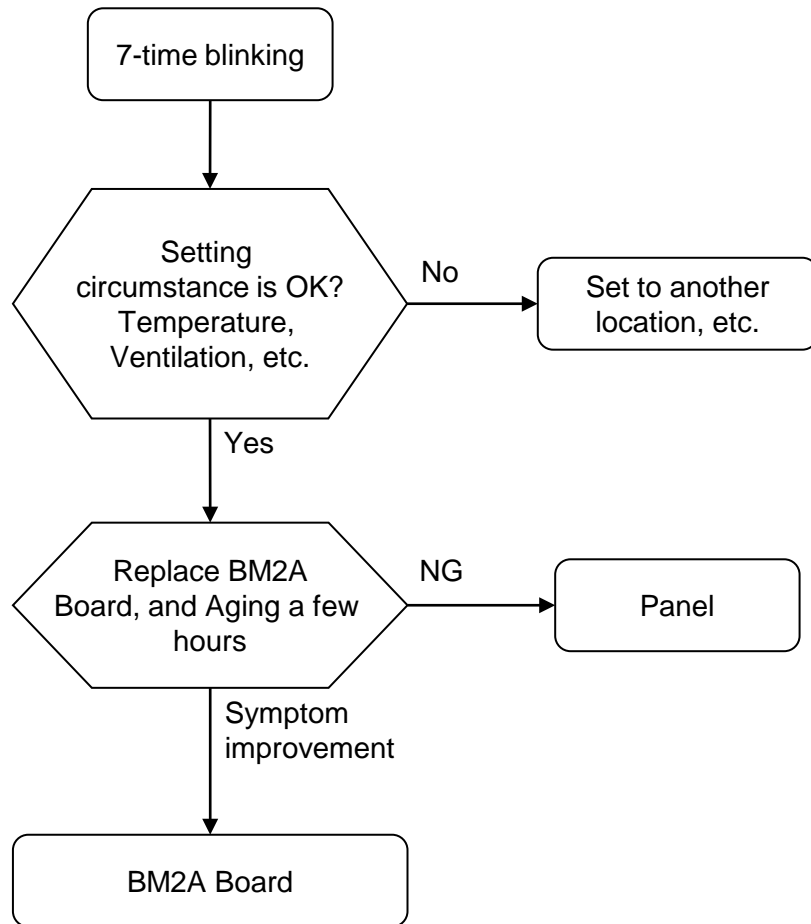

## 2.8 LED BLINKING: 8x (4KBE Error)

### BM2A

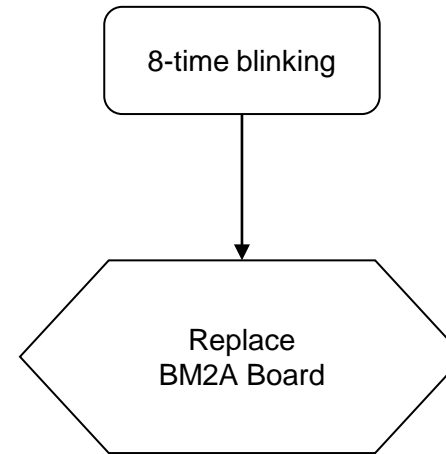

### 3.0 No Sound

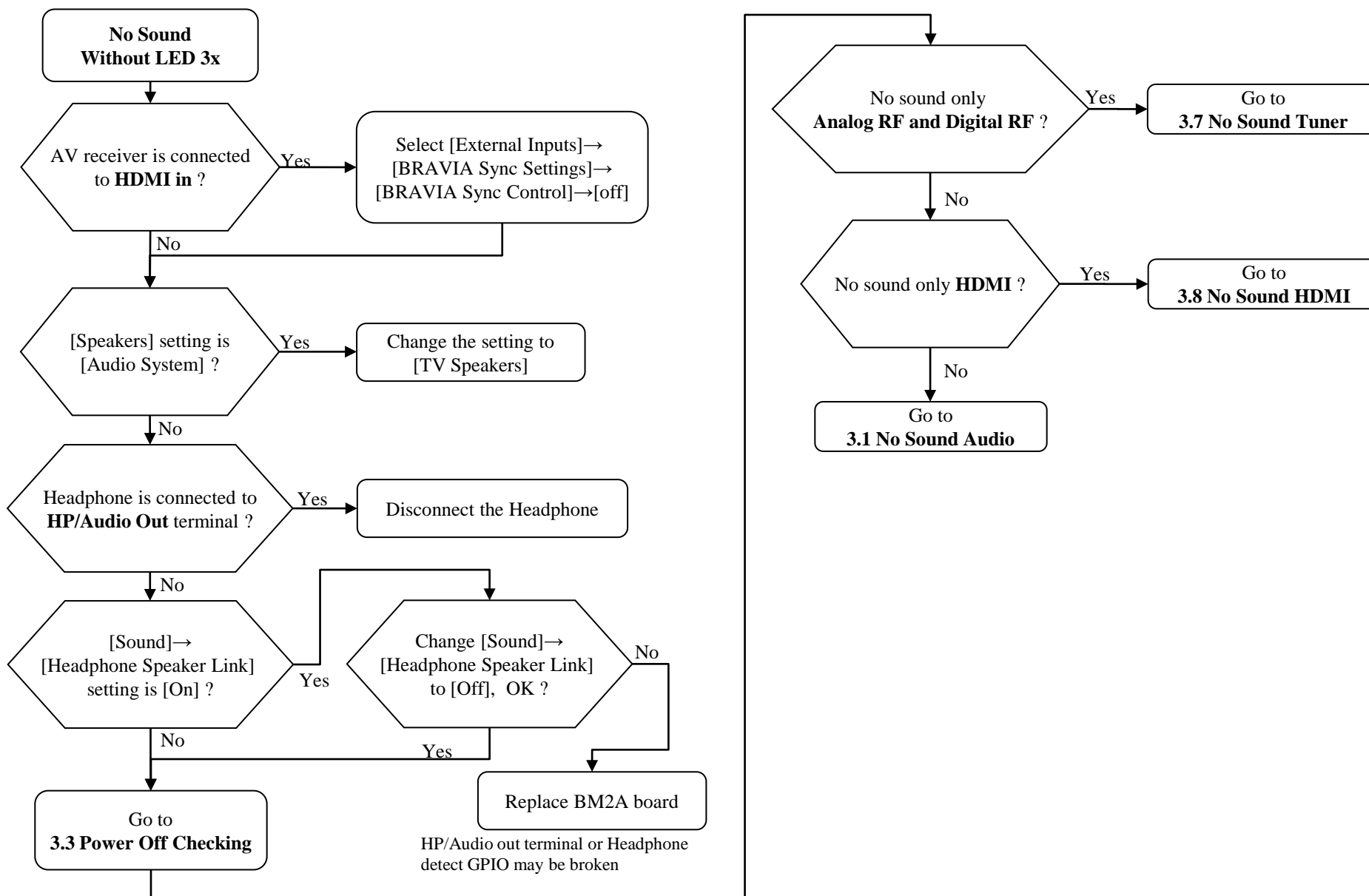

### 3.1 No Sound Audio

---

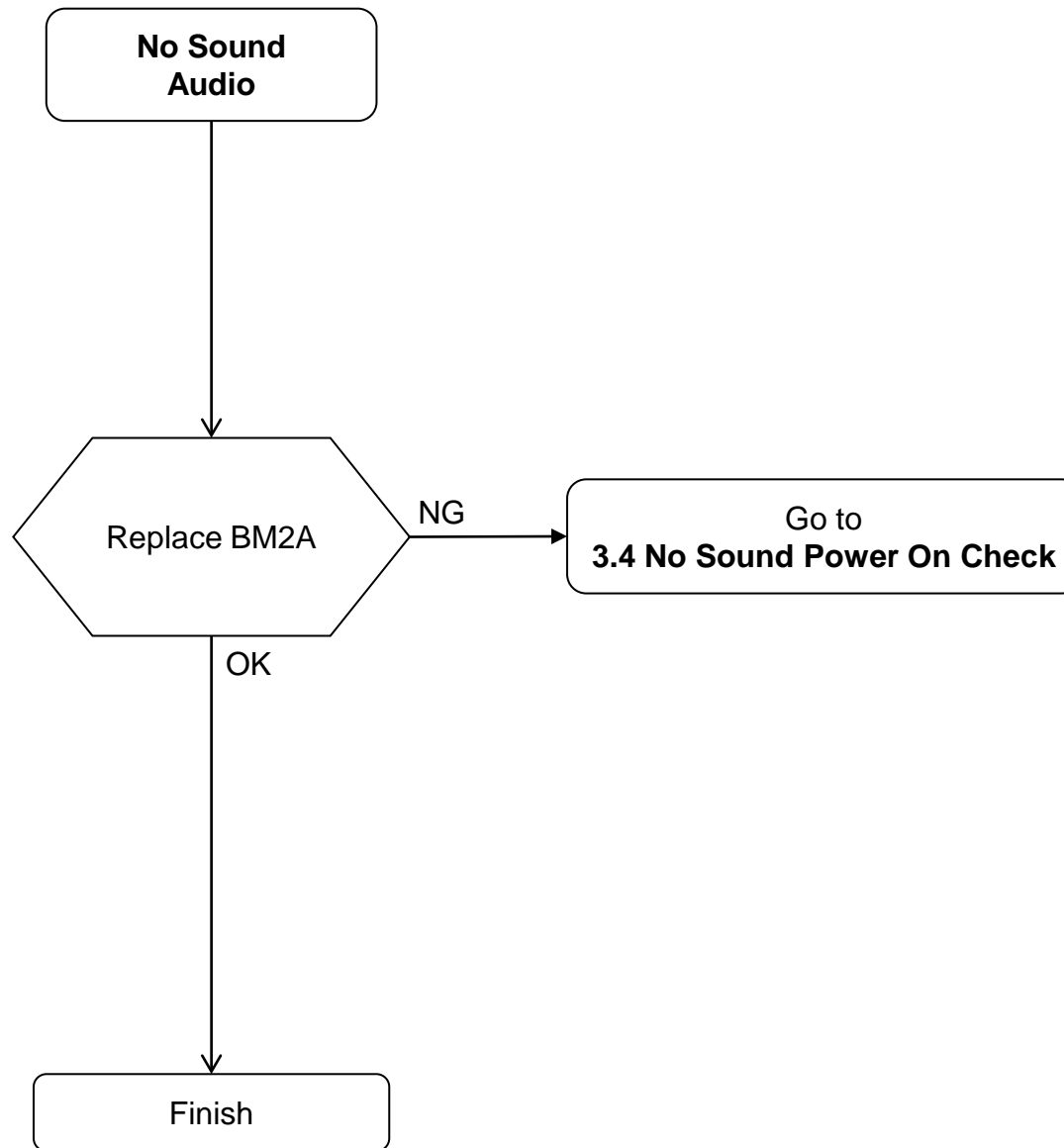

### 3.3 No Sound Power Off Check

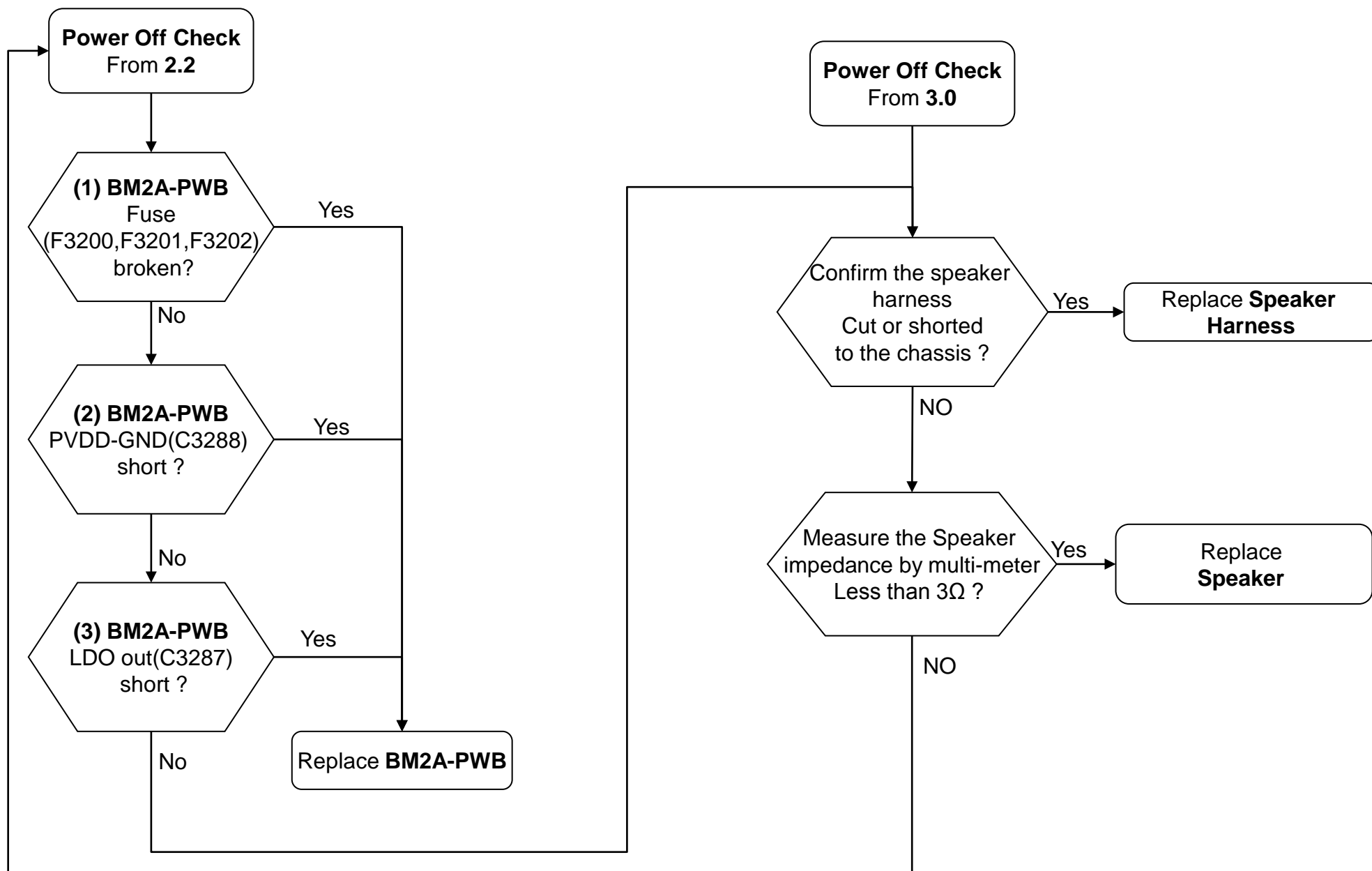

### 3.4 No Sound Power On Check

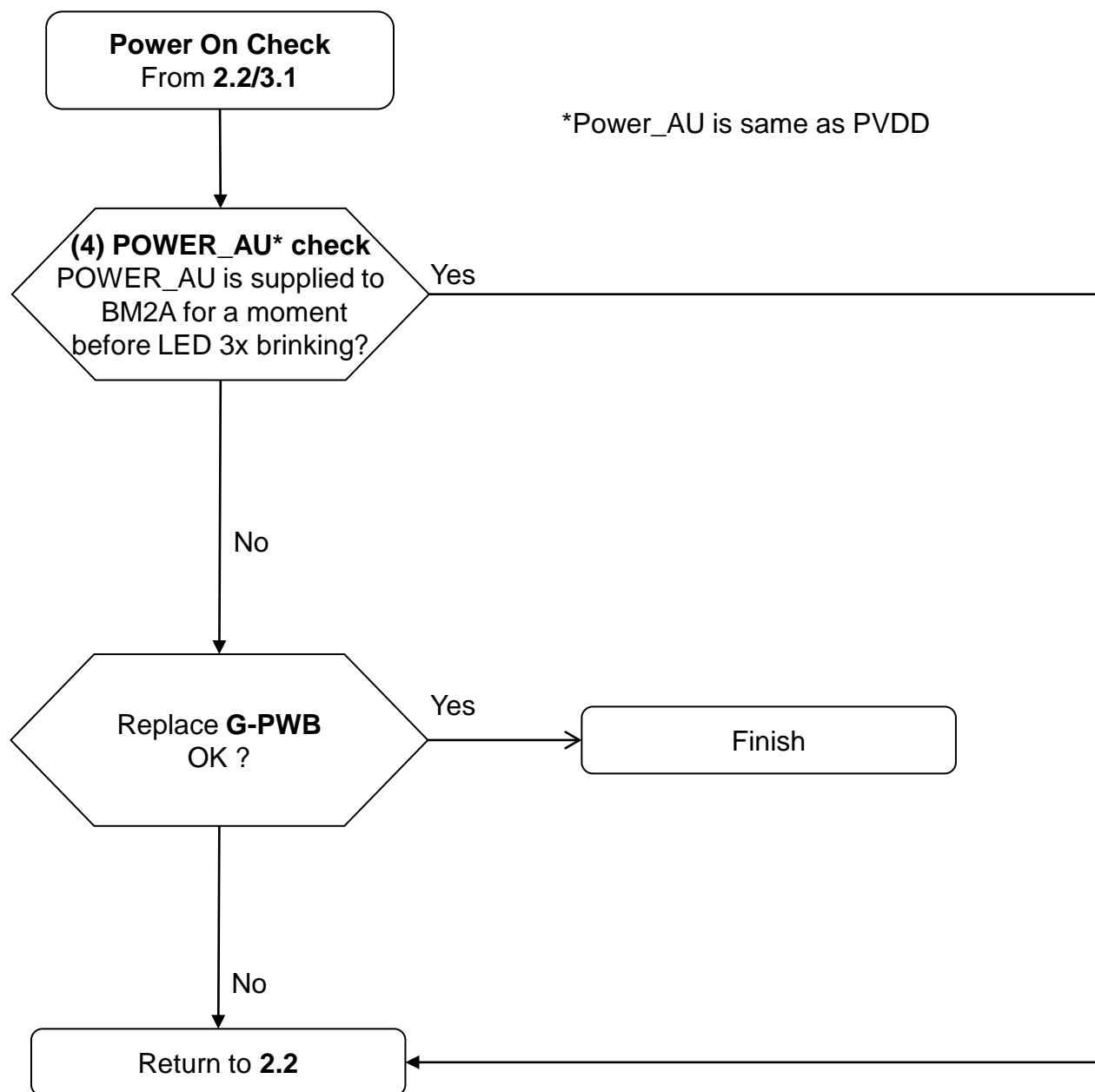

### 3.5 No Sound Audio HP/Audio out

---

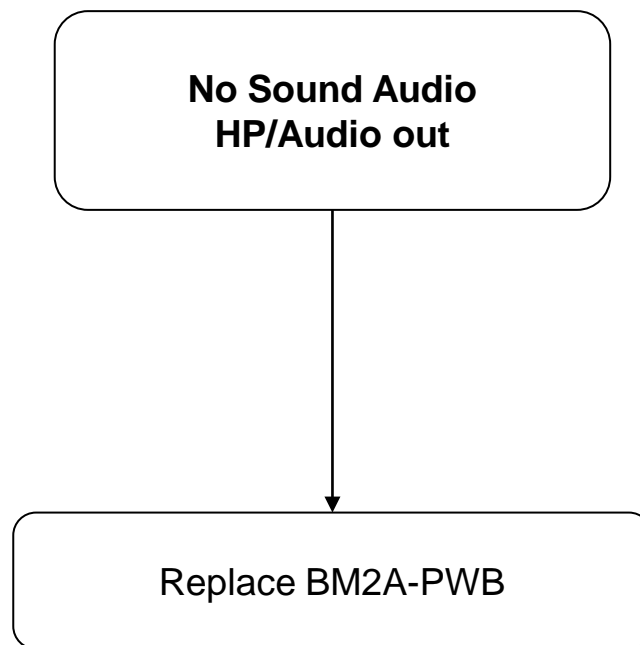

### 3.7 NO SOUND: @ TUNER

---

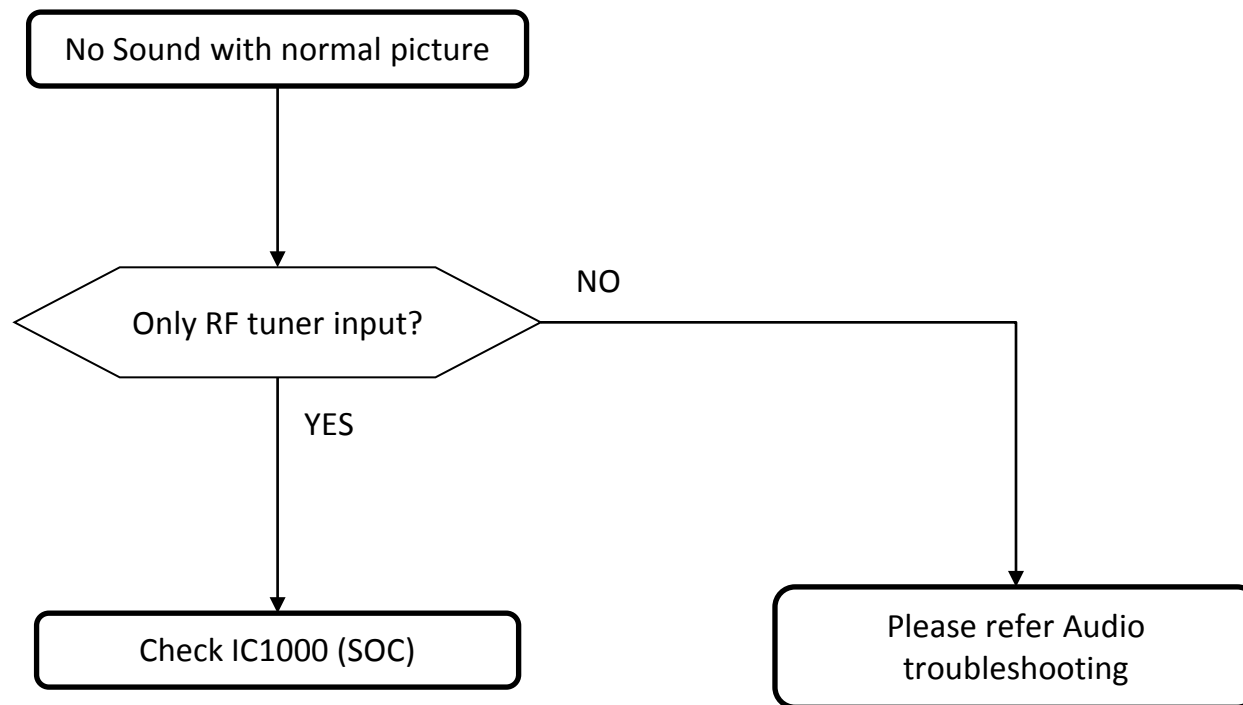

### 3.8 NO SOUND: HDMI1/2/3/4

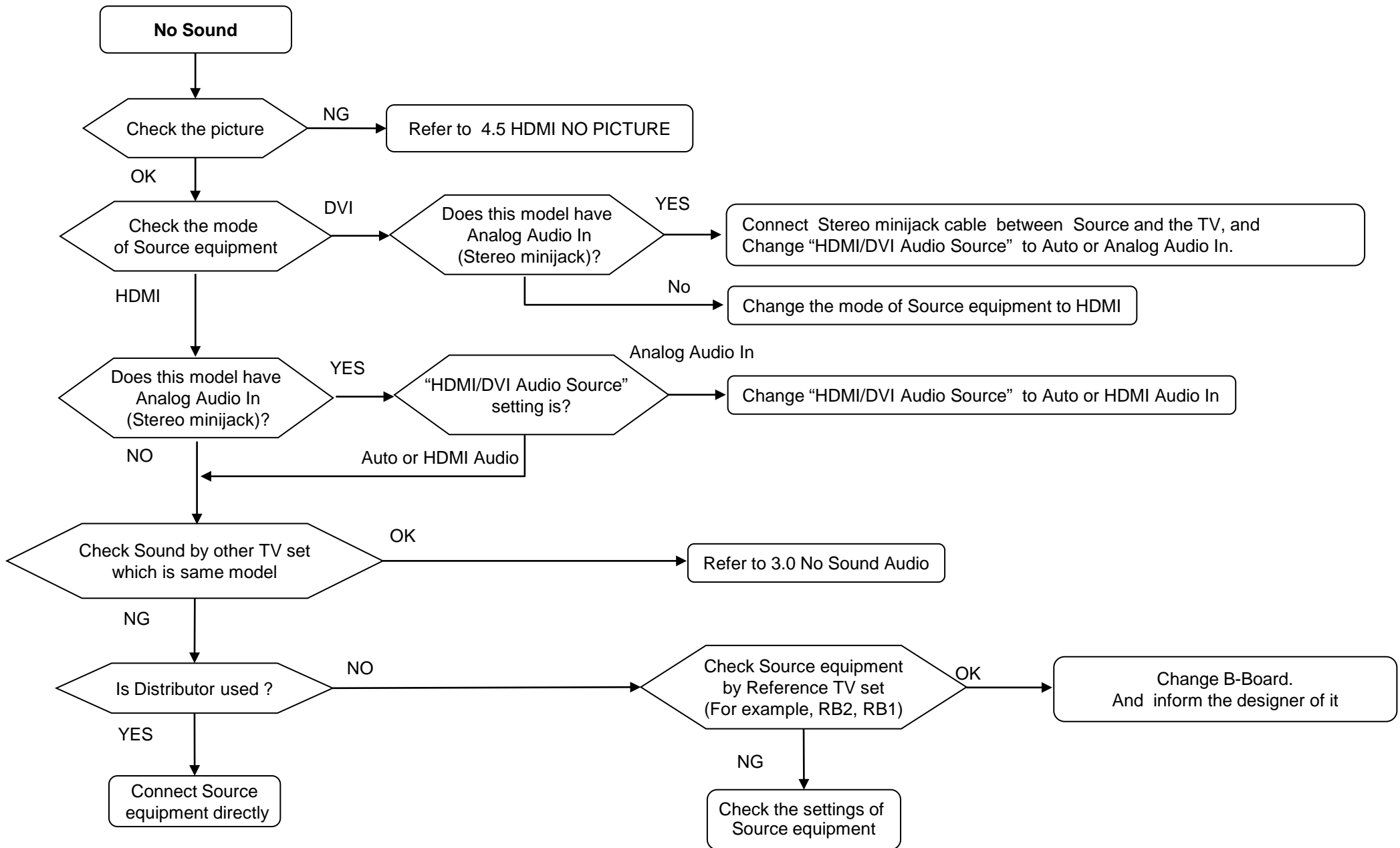

## 4.0 NO PICTURE

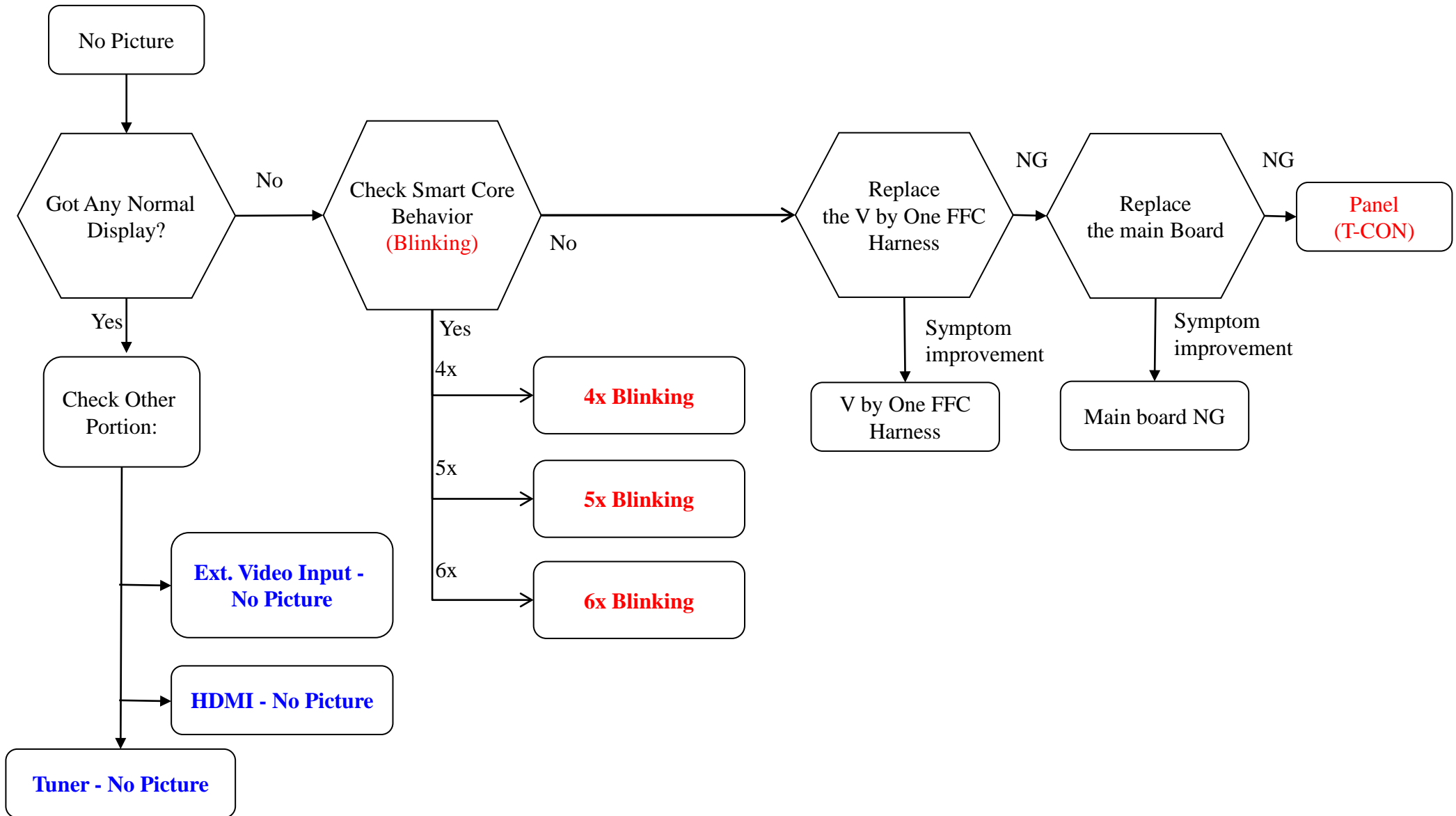

## 4.1 : Video Analog Signal Path

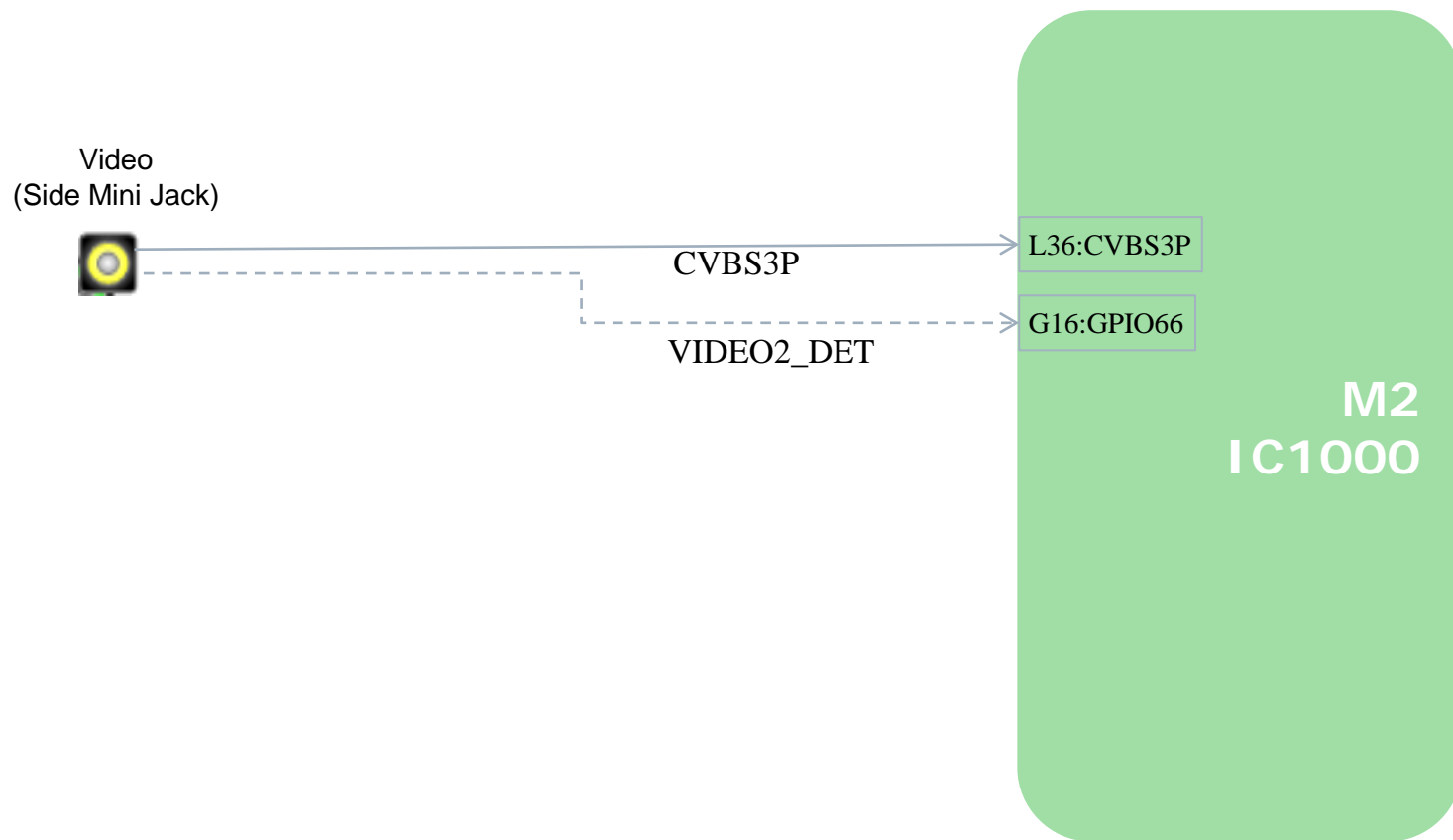

## 4.2 : No Picture (BM2A)

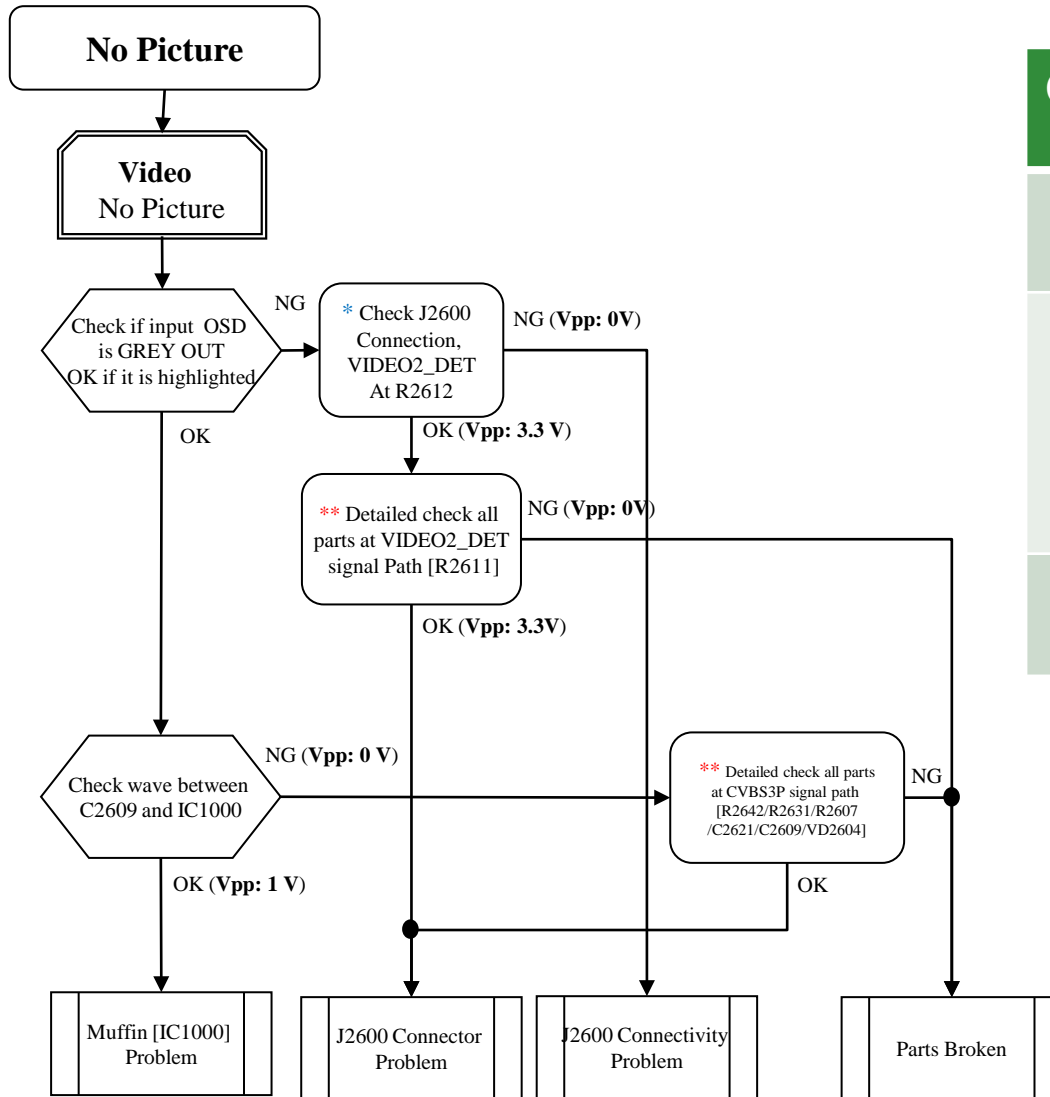

Condition	Actions to be taken
Muffin [IC1000] Problem	Refer to IC troubleshooting for further investigation
J2600 Connector Problem	
J2600 Connectivity Problem	Change Connector
Parts Broken	
	Change Part

\* → OK Condition : No solder splash can be seen  
 → NG Condition : Solder splash can be seen

\*\* → OK Condition : No part short-circuited  
 → NG Condition : Part short-circuited

[All voltage measurement using Oscilloscope]

## 4.2/4.3 : Input Skip function (BM2A)

---

Input	Signal	Non-Detect (Typical)	Detect (Typical)
Video	VIDEO2_DET IC1000 G16- GPIO66	0V	3.3V

Video  
(Side Mini Jack)



## 4.4 NO PICTURE: @ TUNER

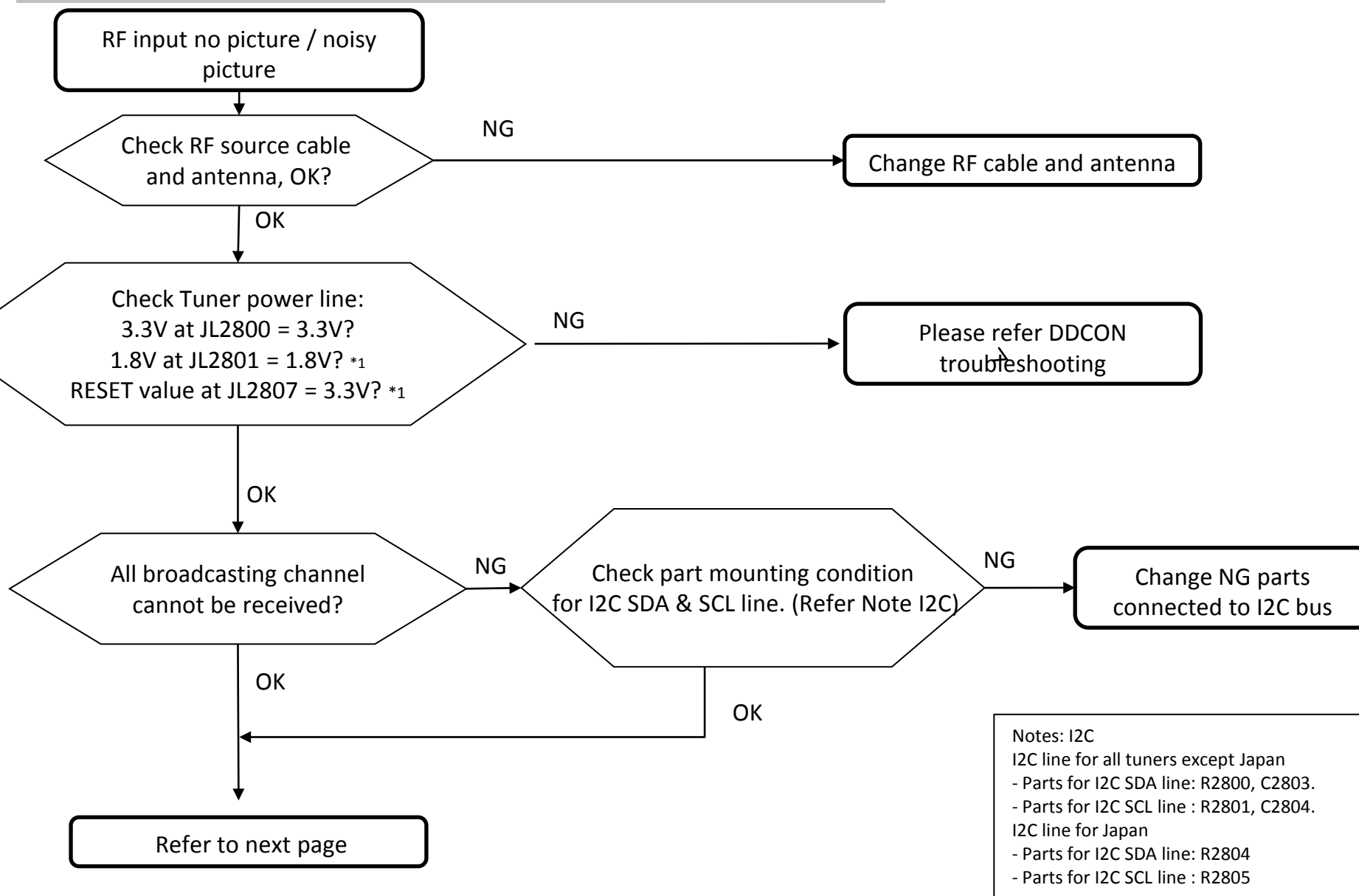

\*1 It does not use 1.8V and RESET in the UC model

### 4.4 NO PICTURE: @ TUNER

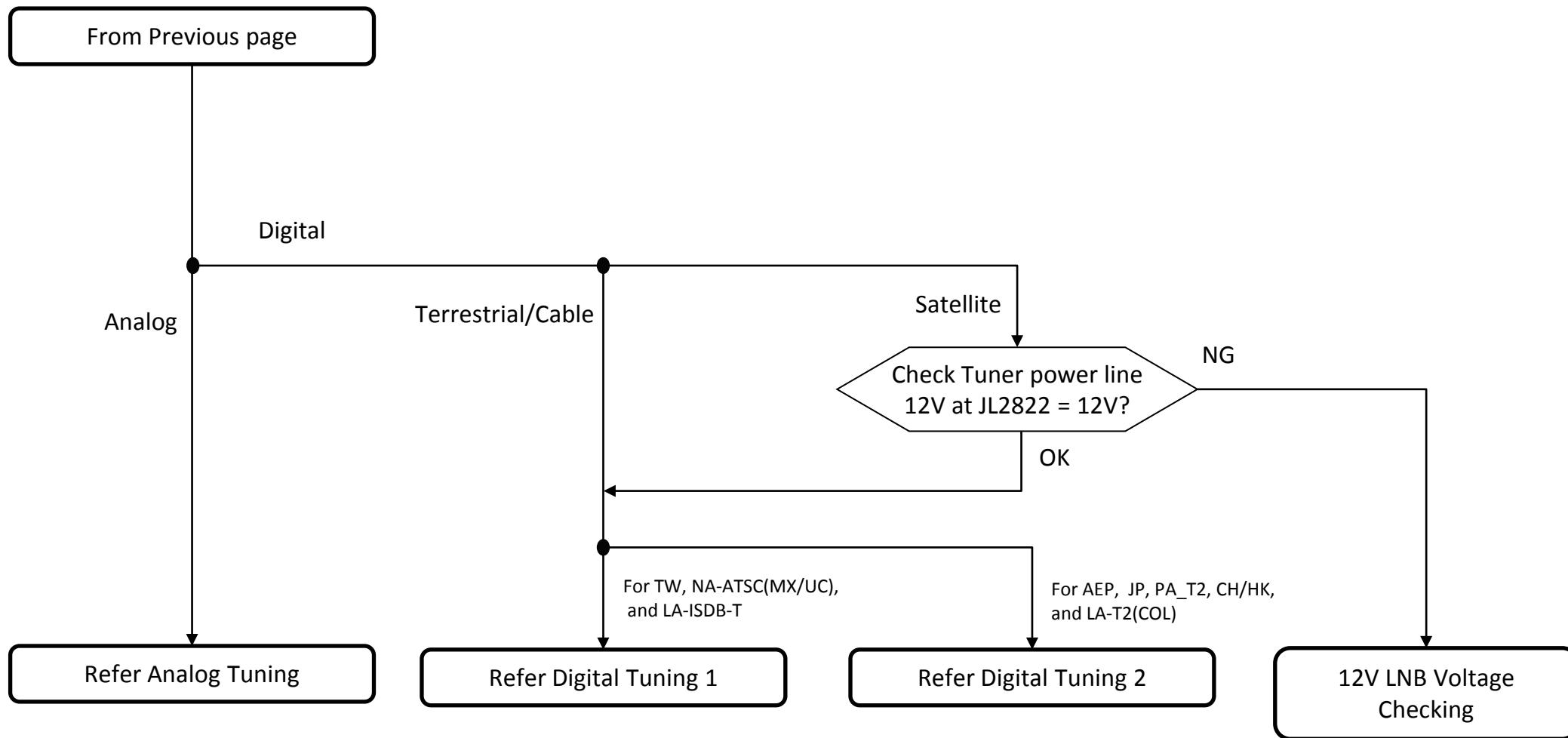

#### 4.4 NO PICTURE: @ TUNER (BM2A)

### BM2A (Top View) For Tuner Power Lines

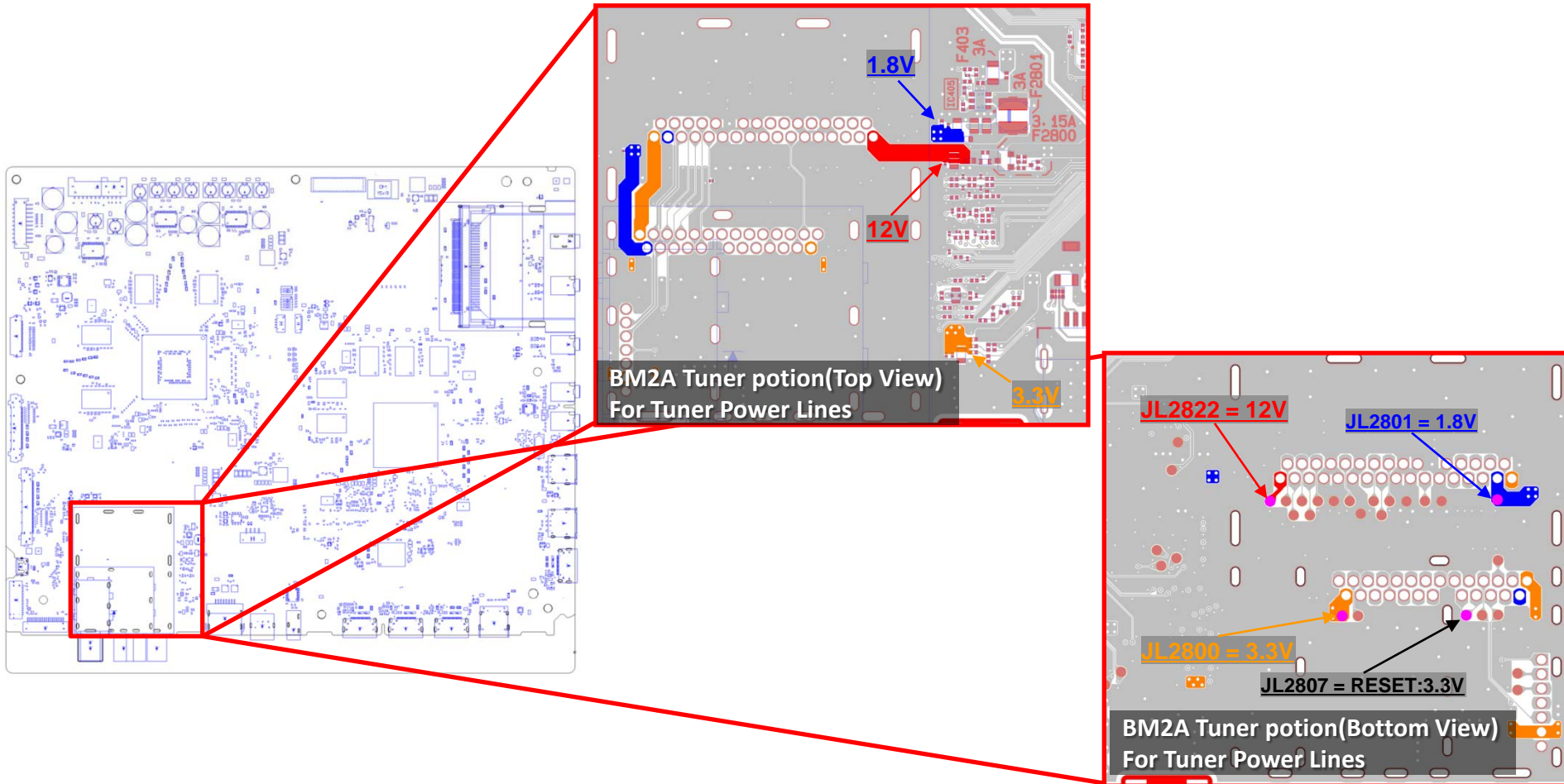

#### 4.4 NO PICTURE: @ TUNER (BM2A)

**BM2A (Top View)  
For Tuner I2C line**

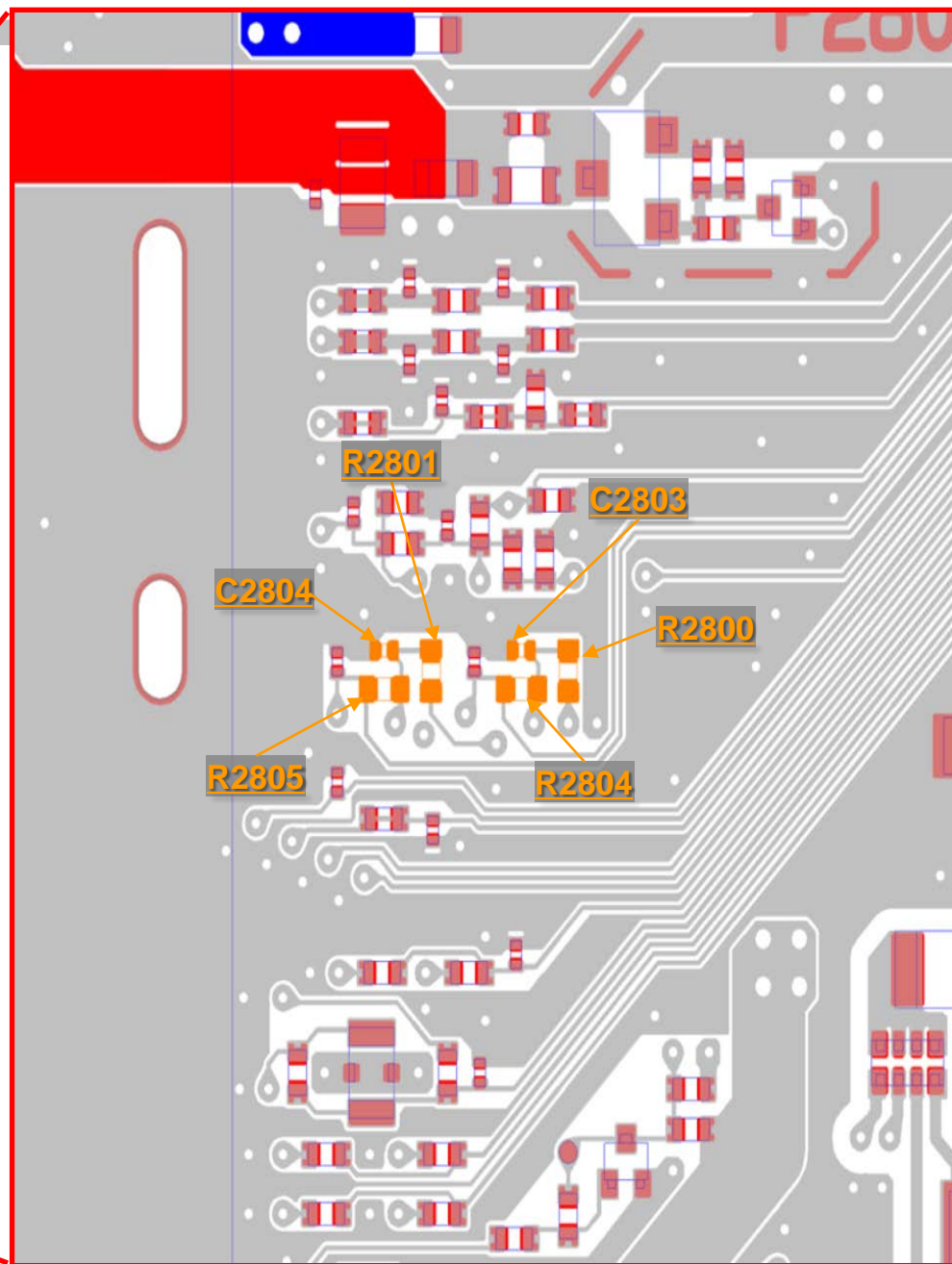
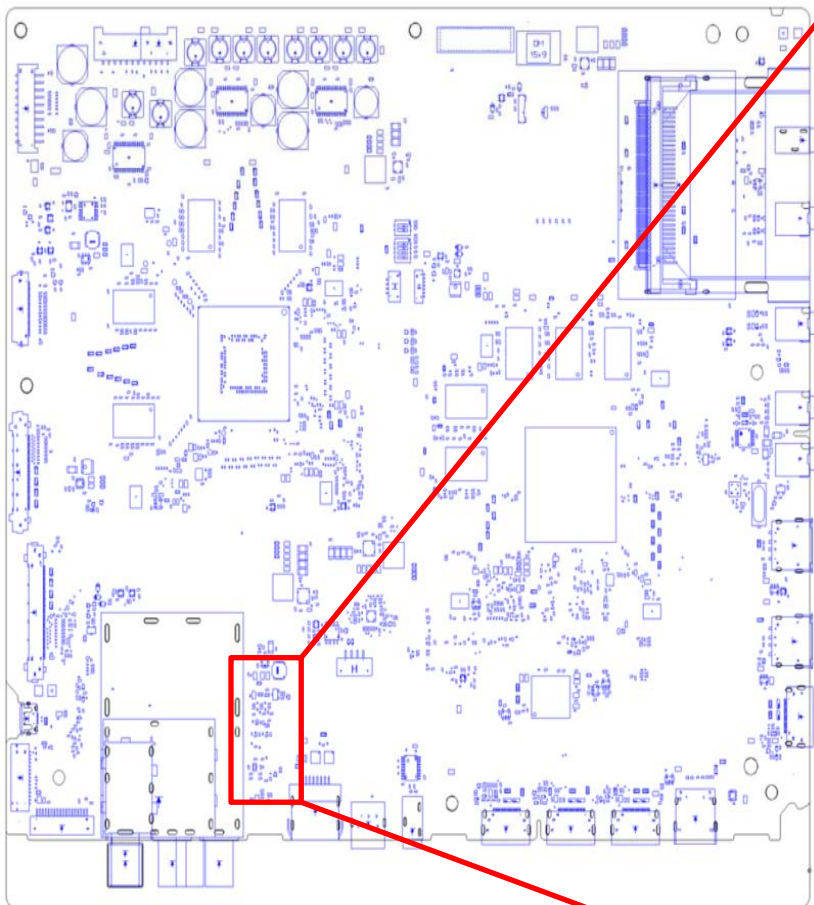

## 4.4 NO PICTURE: @ TUNER

FOR 12V LNB Voltage Checking: @ AEP and JP

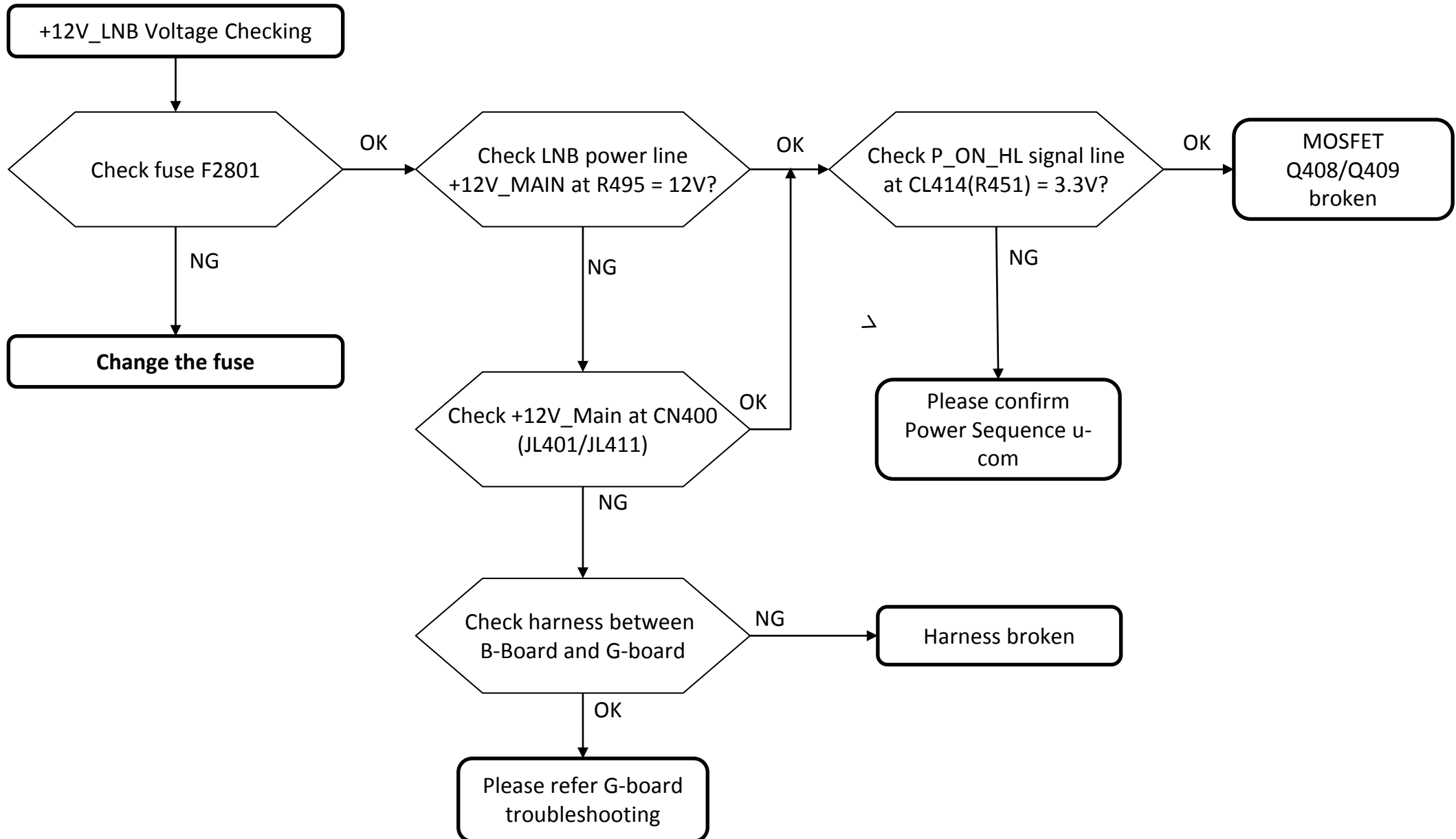

### 4.4 NO PICTURE: @ TUNER (BM2A)

**BM2A (Top View)**  
**12V LNB Voltage line**

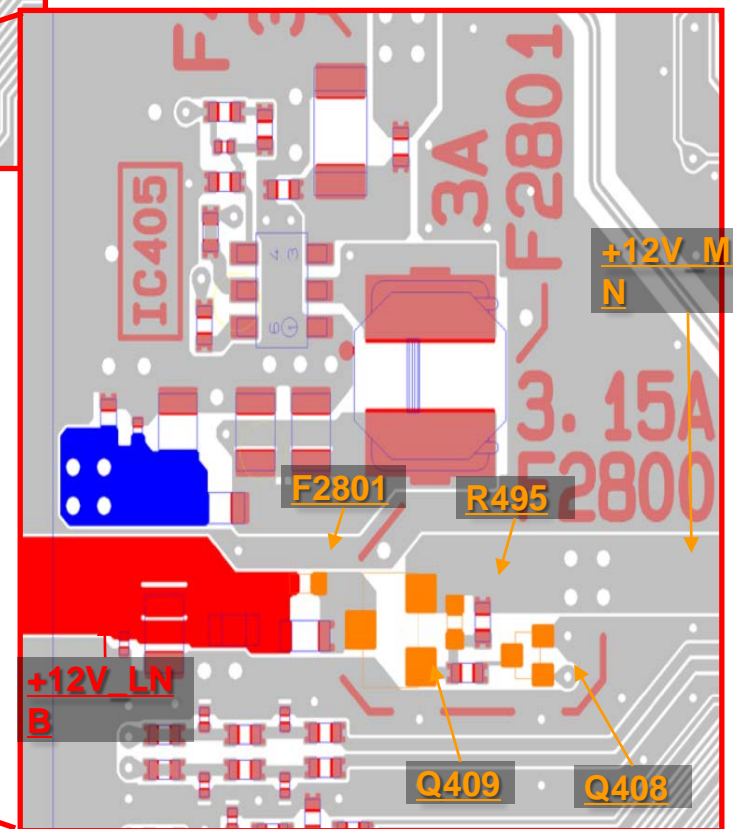
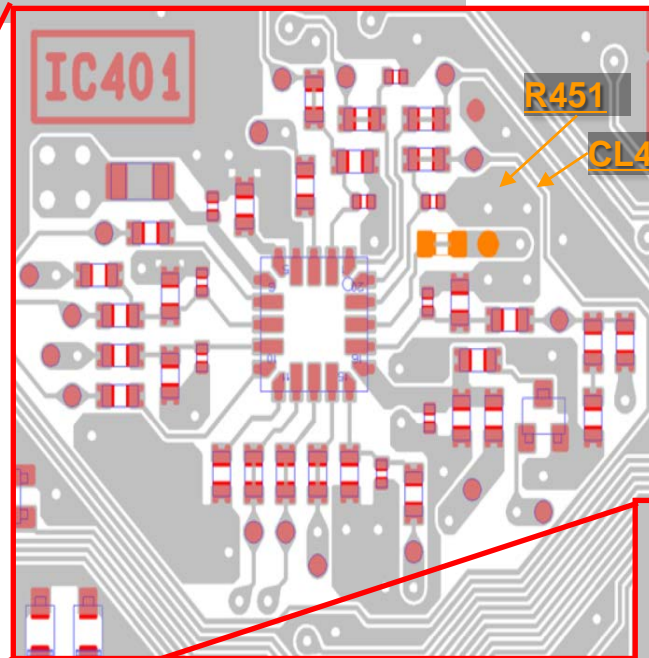
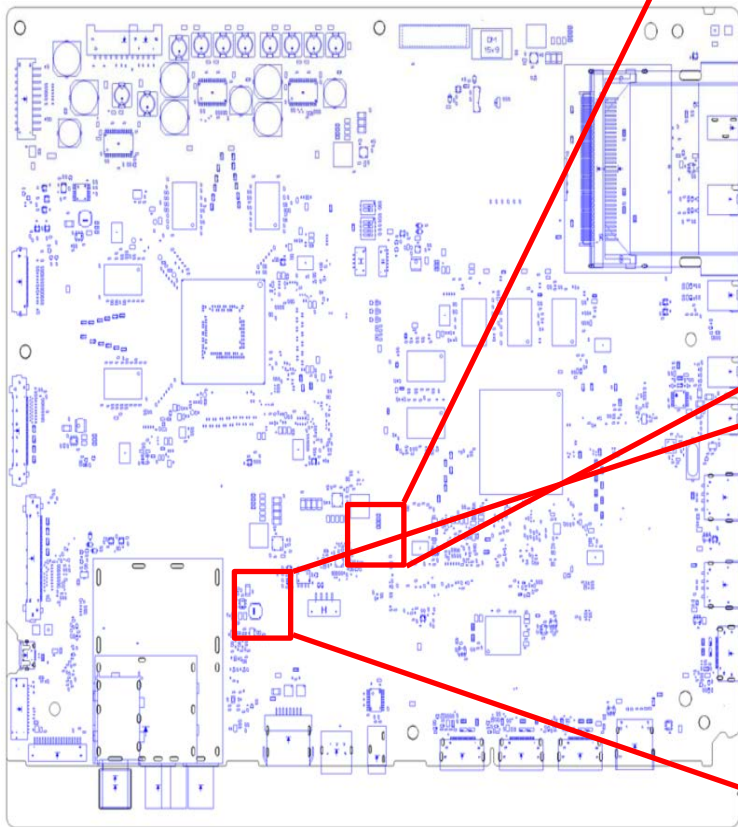

### 4.4 NO PICTURE: @ TUNER

FOR ANALOG TUNING: @ All destination except JP

Notes:  
 - Parts for IFOUT\_N line : FB2801, C2807, C2826  
 - Parts for IFOUT\_P line : FB2802, C2808, C2825  
 - Parts for IFAGC line : R2809, R2838, C2827

(A) : Insert correct signal in correct terminal.

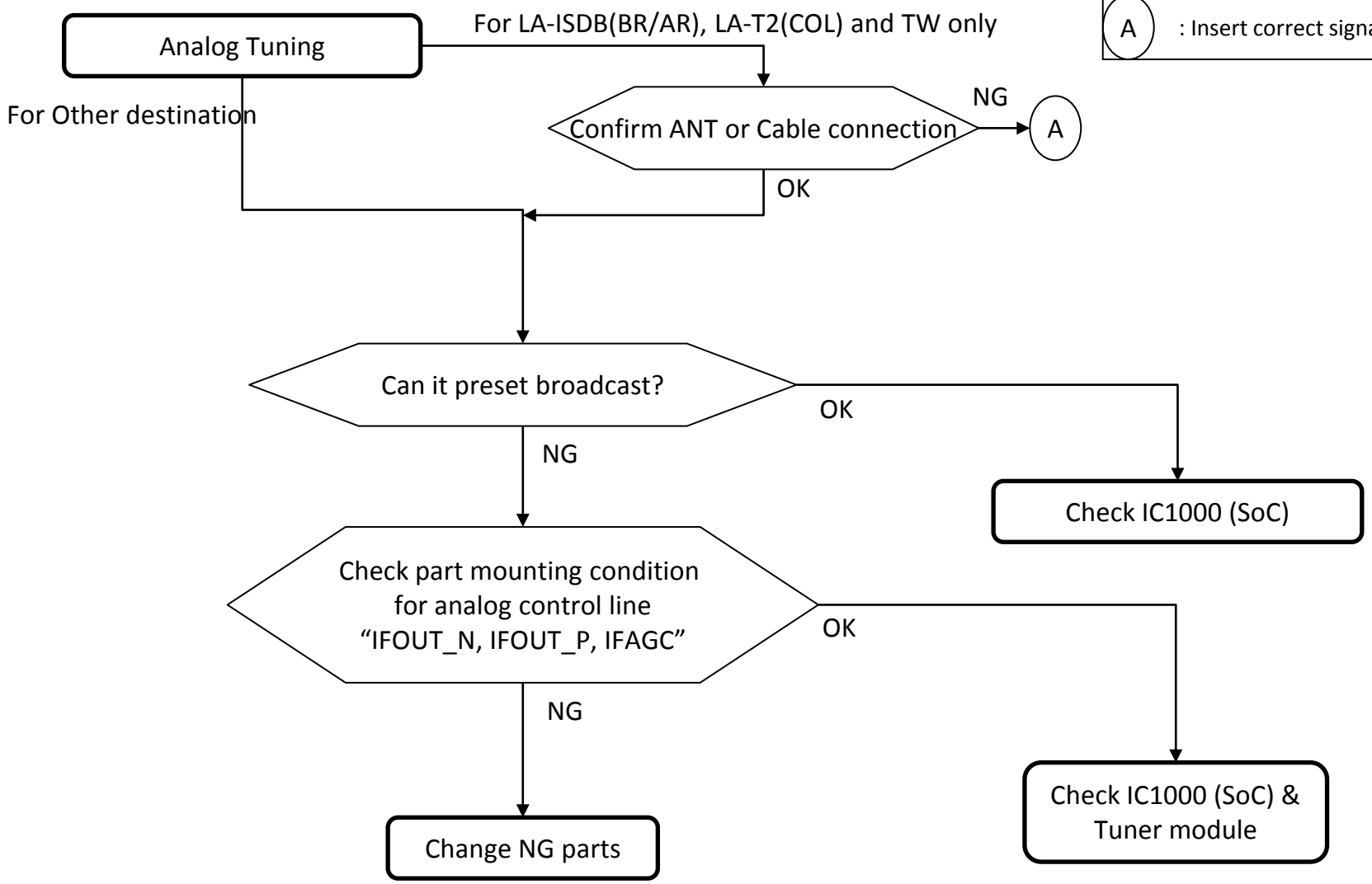

### 4.4 NO PICTURE: @ TUNER

FOR DIGITAL TUNING 1: @ TW, NA-ATSC(MX/UC), and LA-ISDB-T.

Notes:  
 - Parts for IFOUT\_N line : FB2801, C2807, C2826  
 - Parts for IFOUT\_P line : FB2802, C2808, C2825  
 - Parts for IFAGC line : R2809, R2838, C2827

(A) : Insert correct signal in correct terminal.

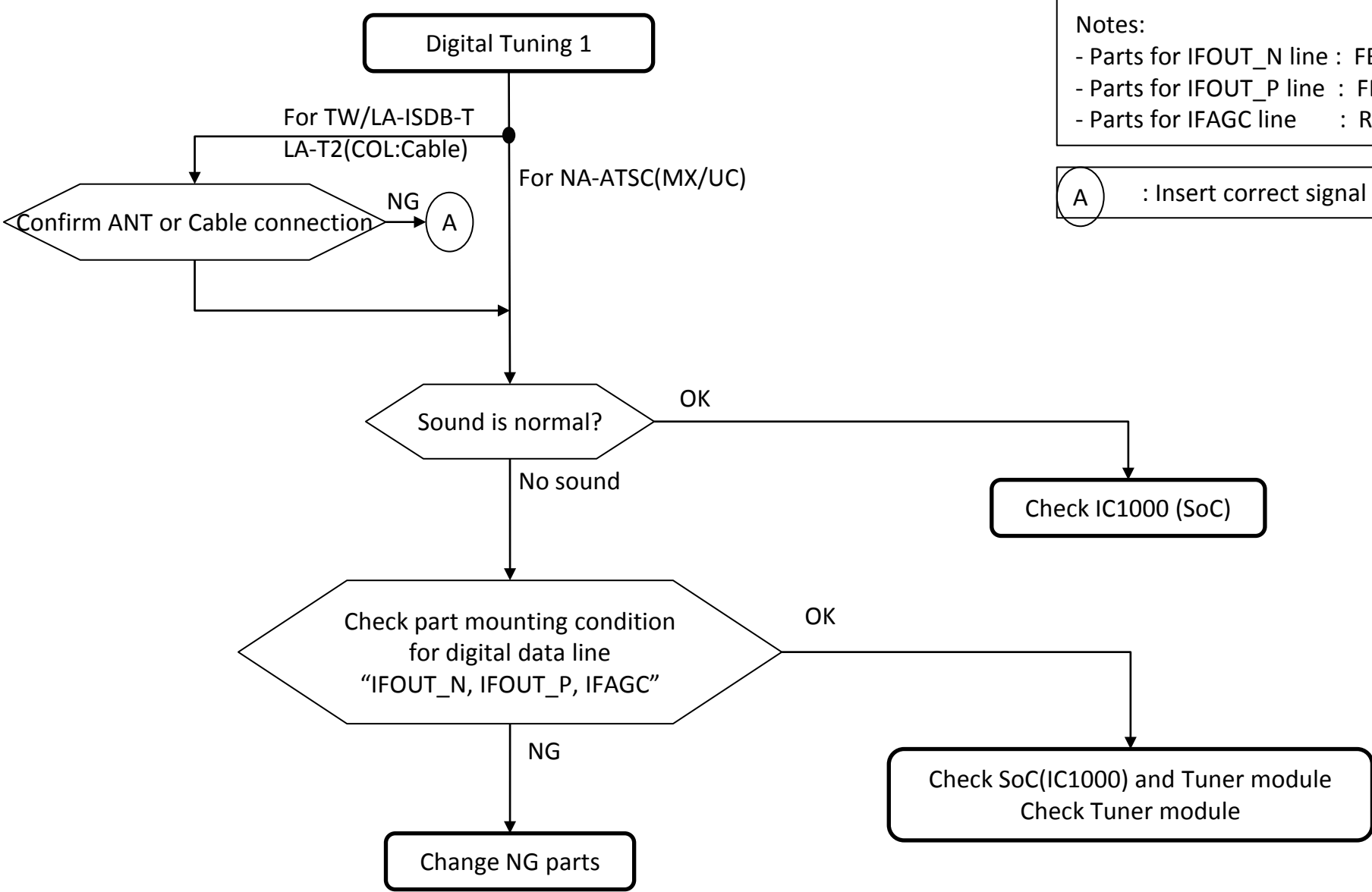

### 4.4 NO PICTURE: @ TUNER (BM2A)

BM2A(Top View)  
IF & IFAGC line

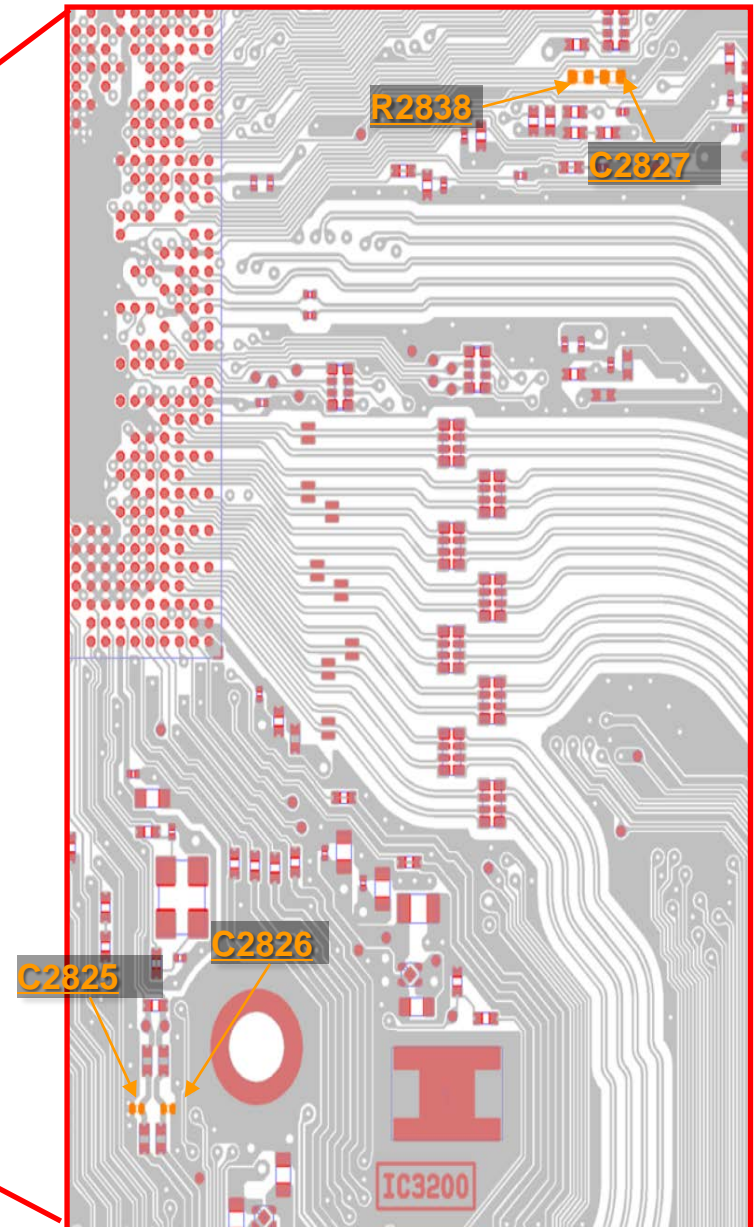
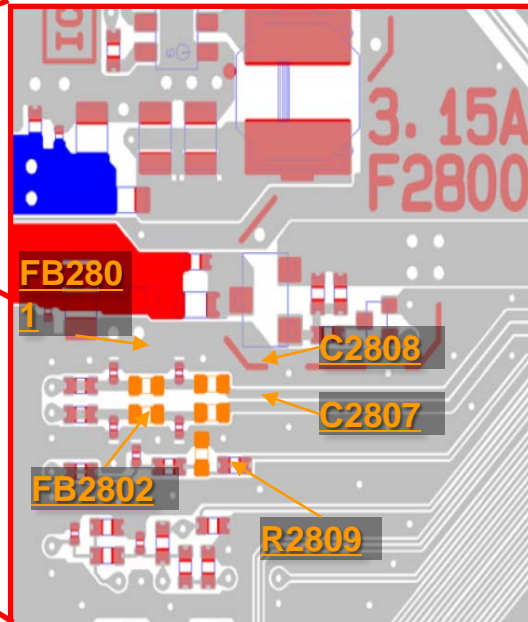
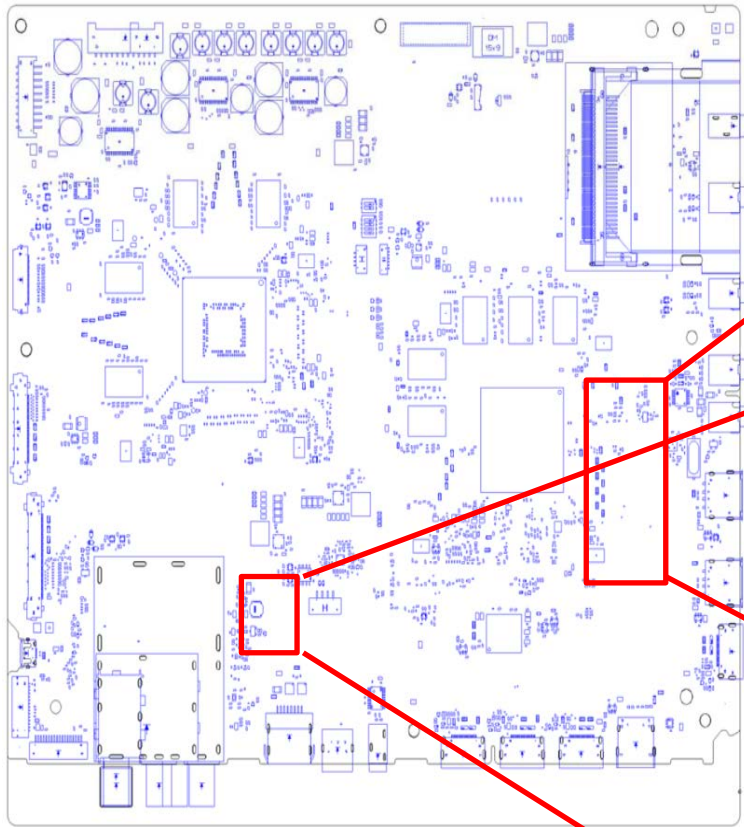

### 4.4 NO PICTURE: @ TUNER

FOR DIGITAL TUNING 2: @ AEP, JP, PA\_T2, CH/HK, and LA-T2(COL)

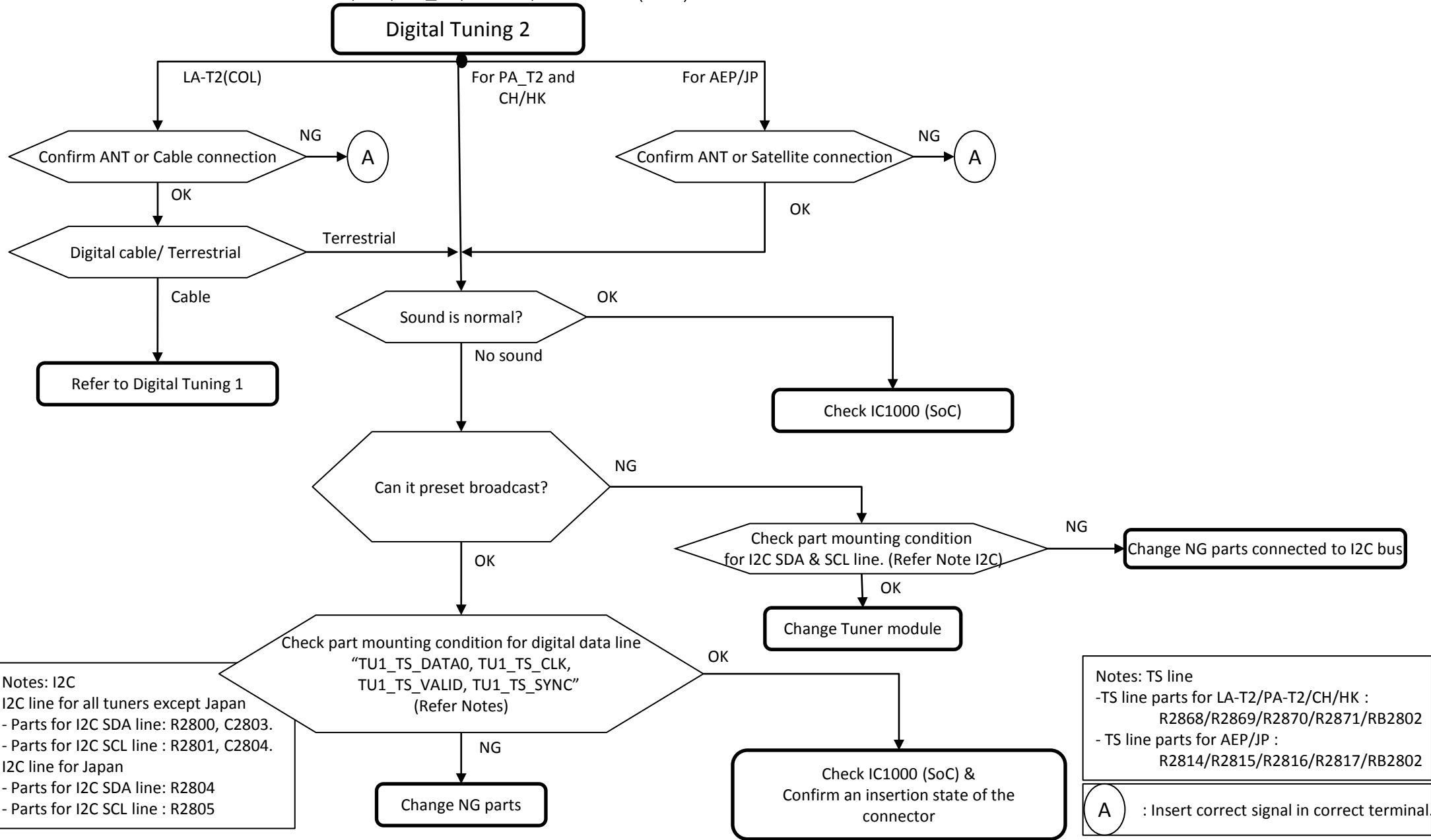

Notes: I2C  
 I2C line for all tuners except Japan  
 - Parts for I2C SDA line: R2800, C2803.  
 - Parts for I2C SCL line : R2801, C2804.  
 I2C line for Japan  
 - Parts for I2C SDA line: R2804  
 - Parts for I2C SCL line : R2805

Notes: TS line  
 -TS line parts for LA-T2/PA-T2/CH/HK :  
 R2868/R2869/R2870/R2871/RB2802  
 - TS line parts for AEP/JP :  
 R2814/R2815/R2816/R2817/RB2802

(A) : Insert correct signal in correct terminal.

#### 4.4 NO PICTURE: @ TUNER (BM2A)

**BM2A (Top View)**

**TS1 line**

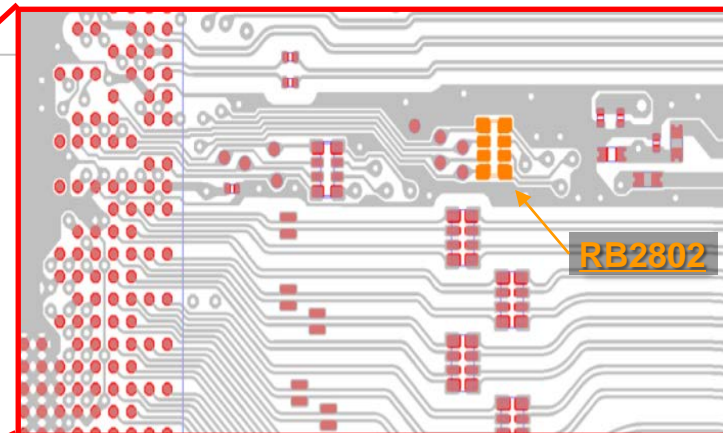
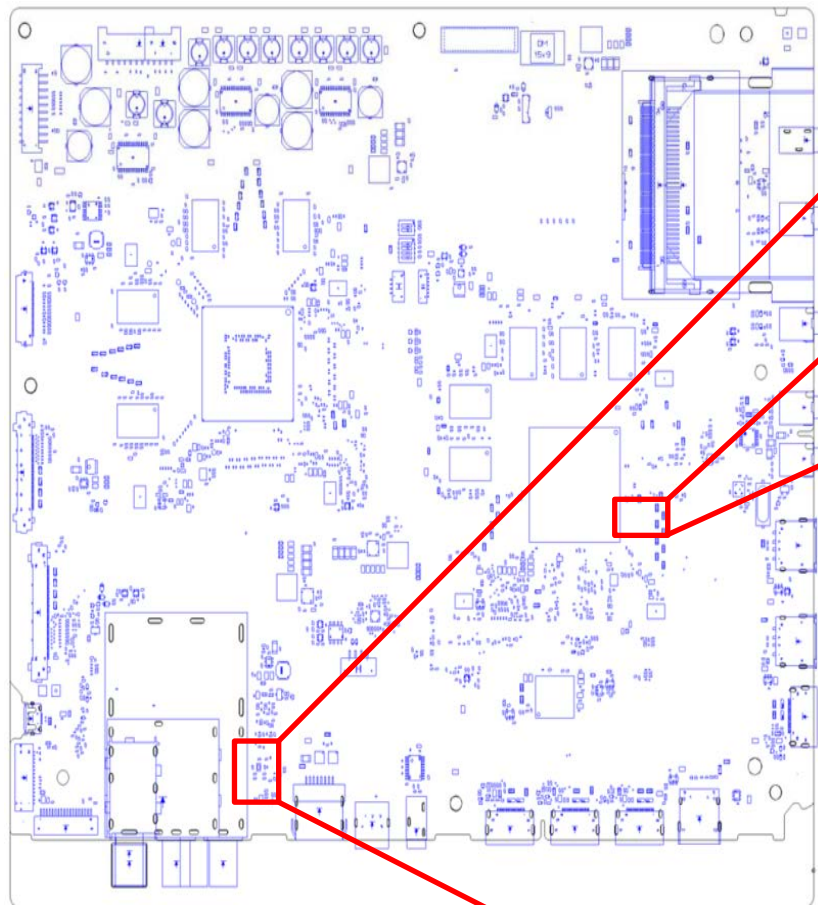

(Under the heatsink)

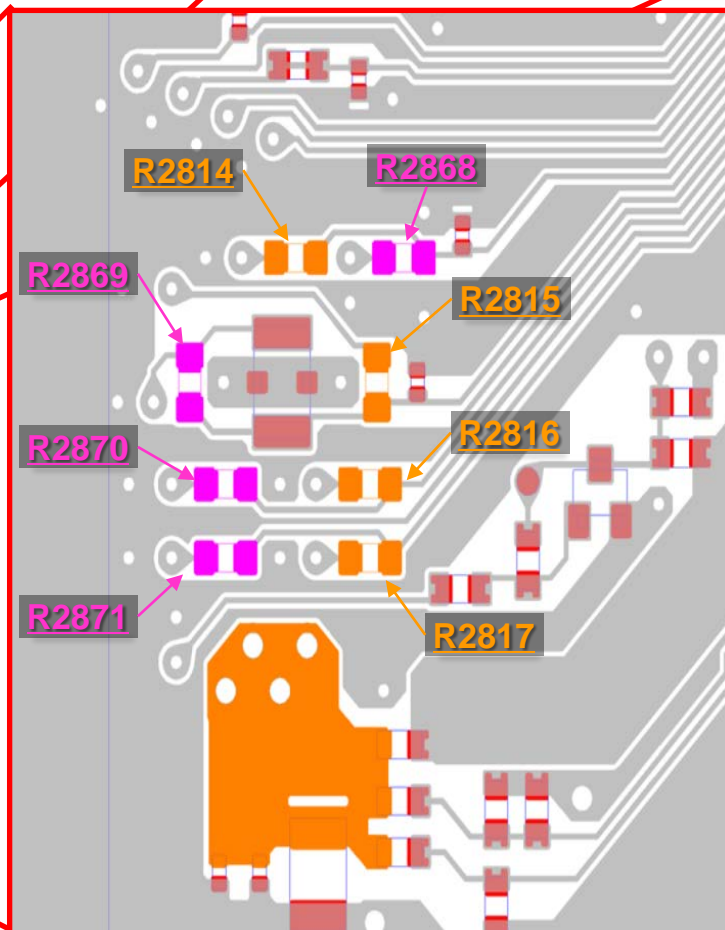

### 4.5 NO PICTURE: HDMI1

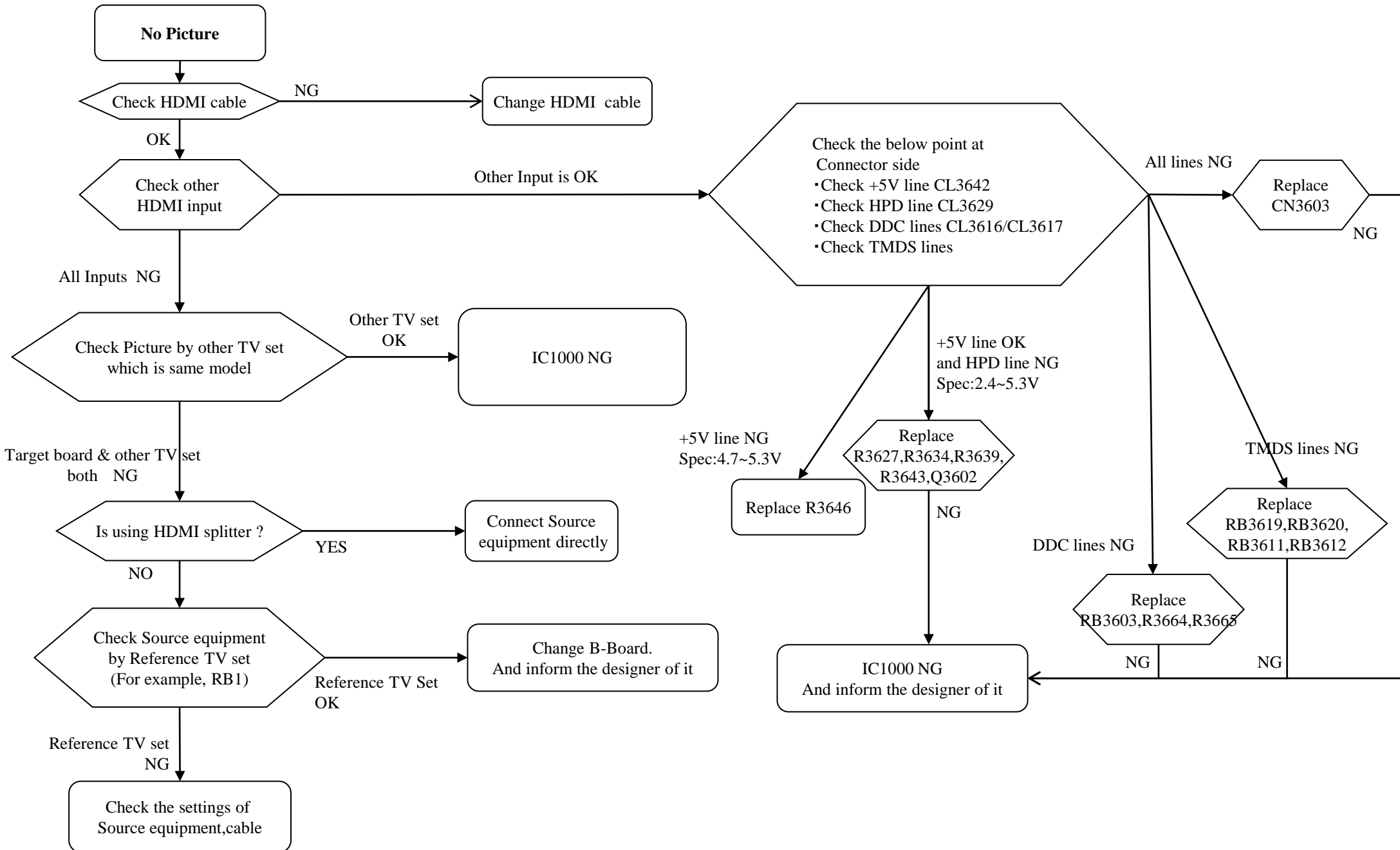

### 4.5 NO PICTURE: HDMI2

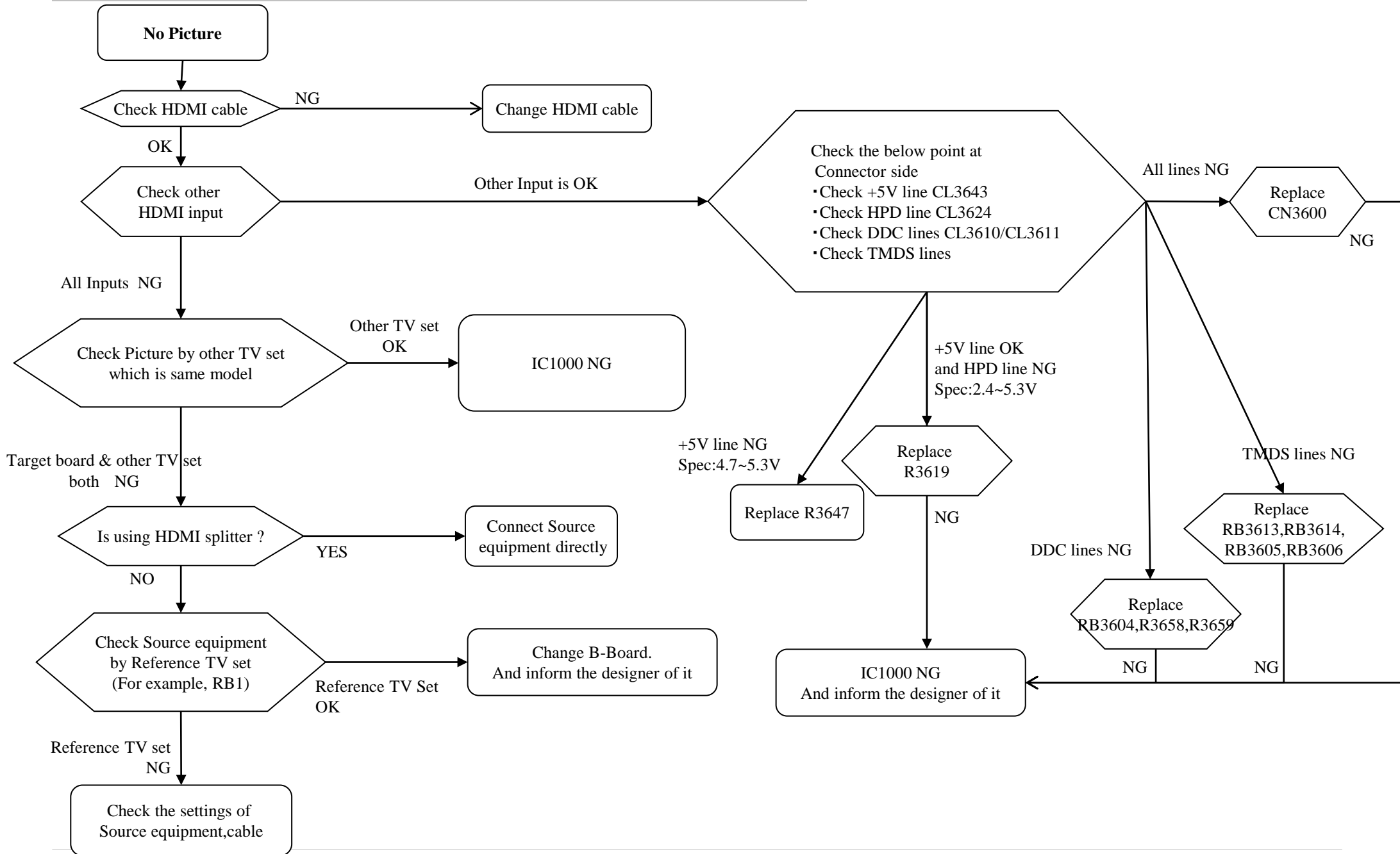

### 4.5 NO PICTURE: HDMI3

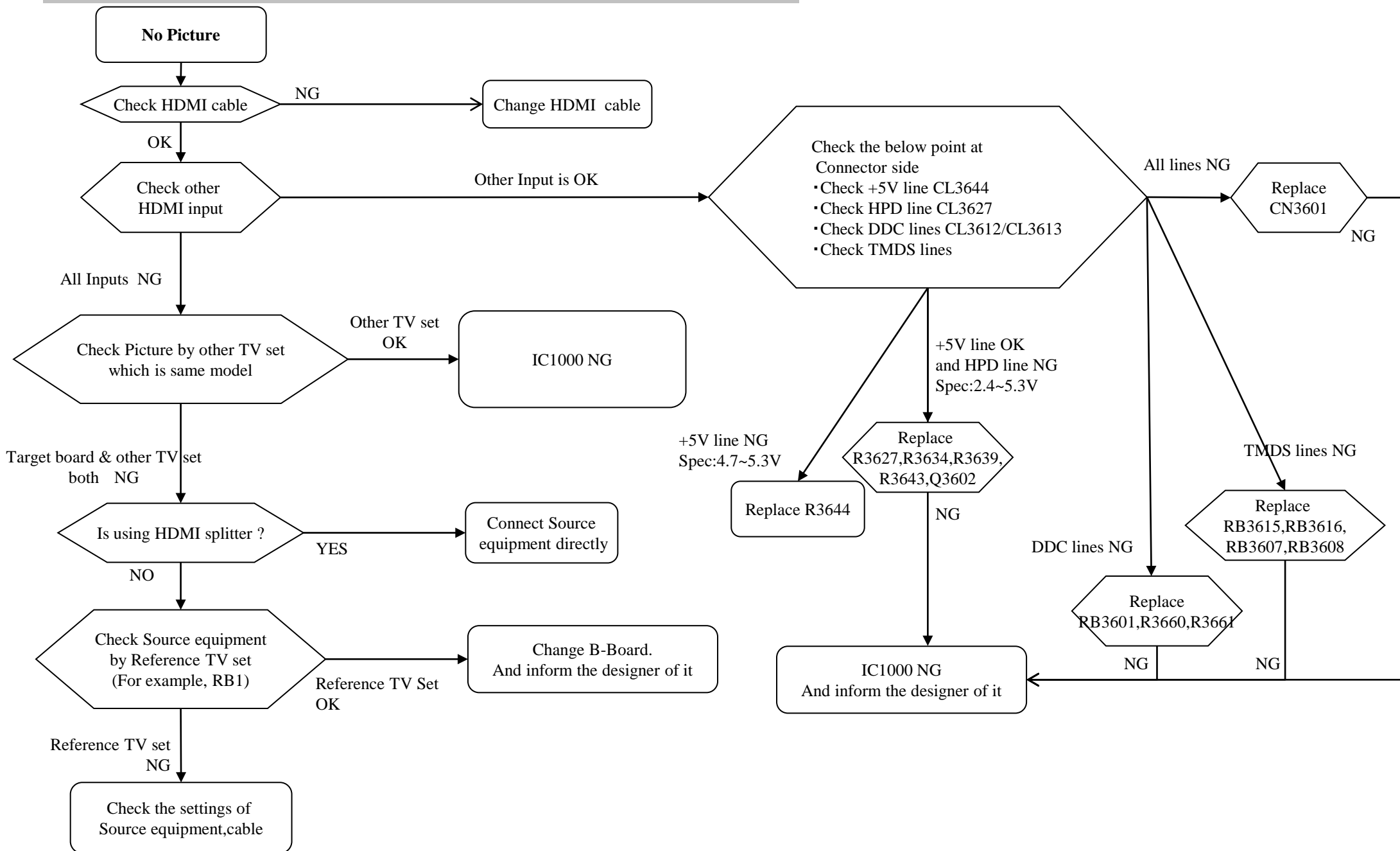

### 4.5 NO PICTURE: HDMI4

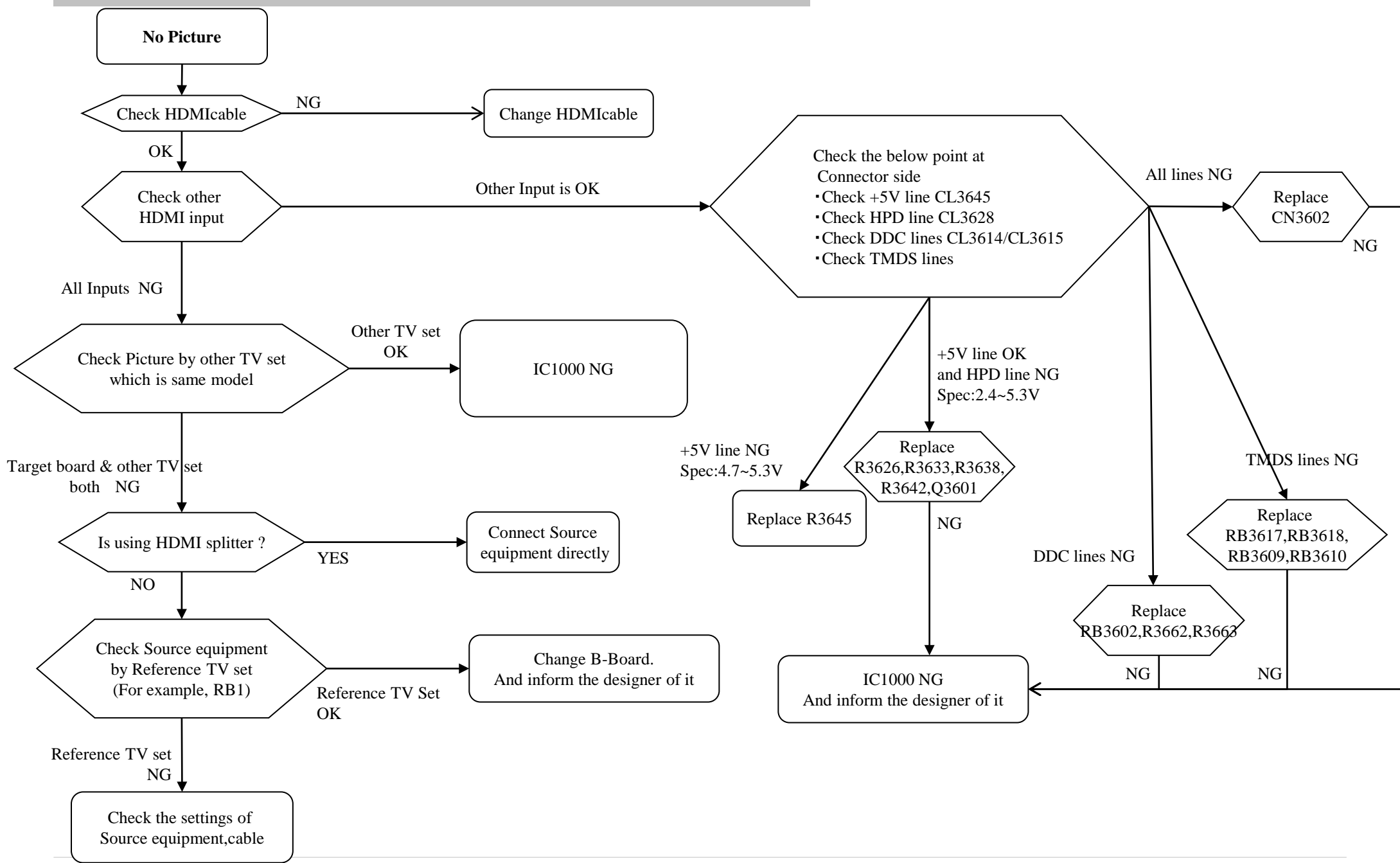

## 5.0 Key Switch Buttons Error

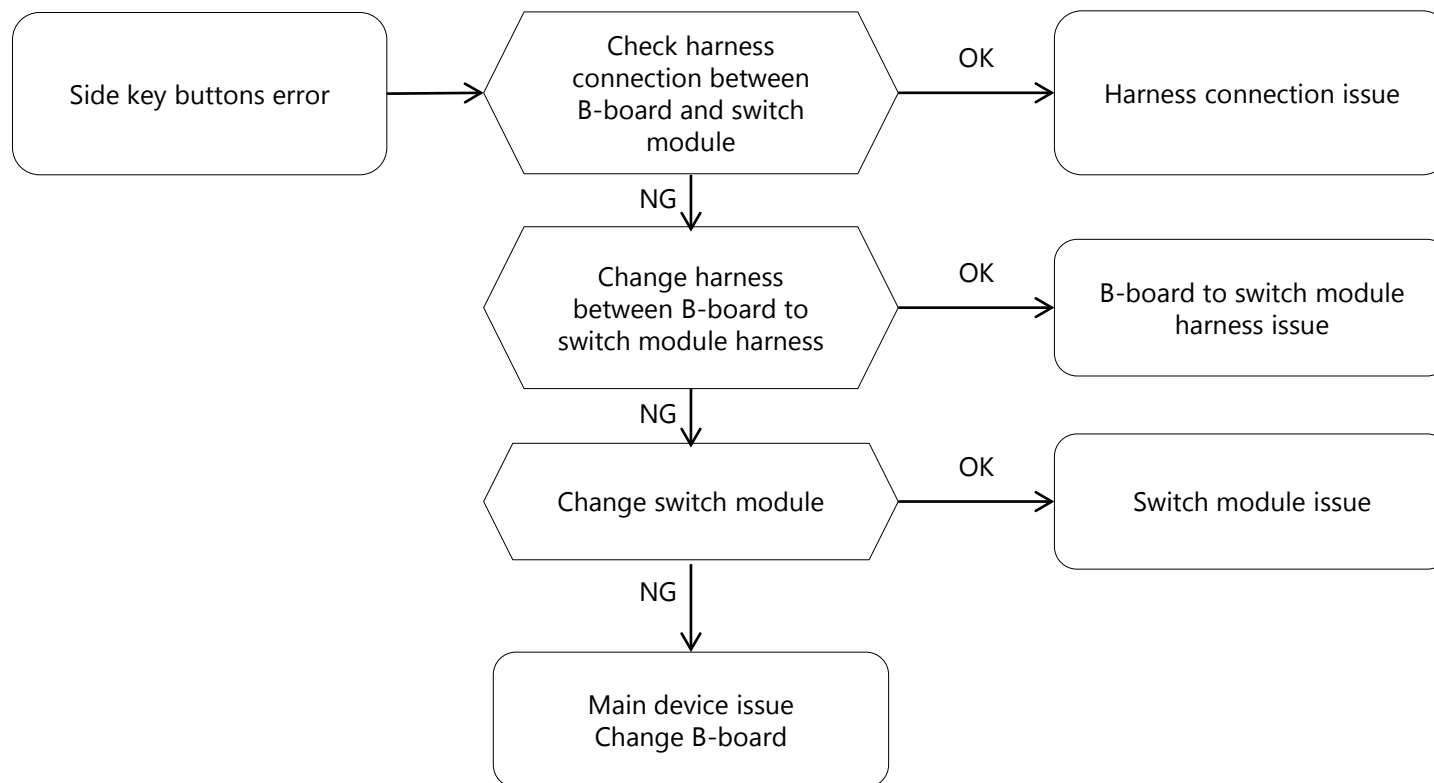

## 5.1 IR Remote Commander Error

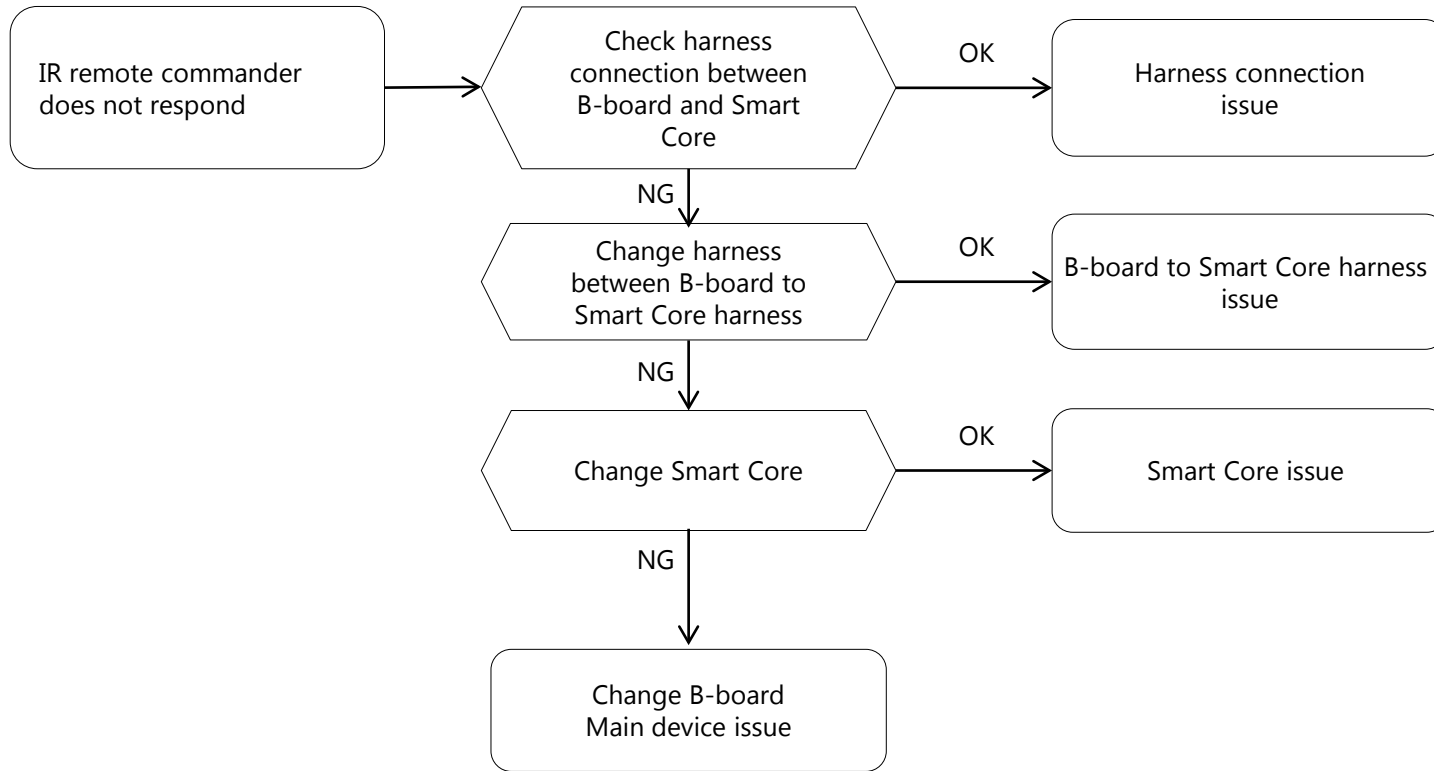

## 5.2 Light Sensor Error

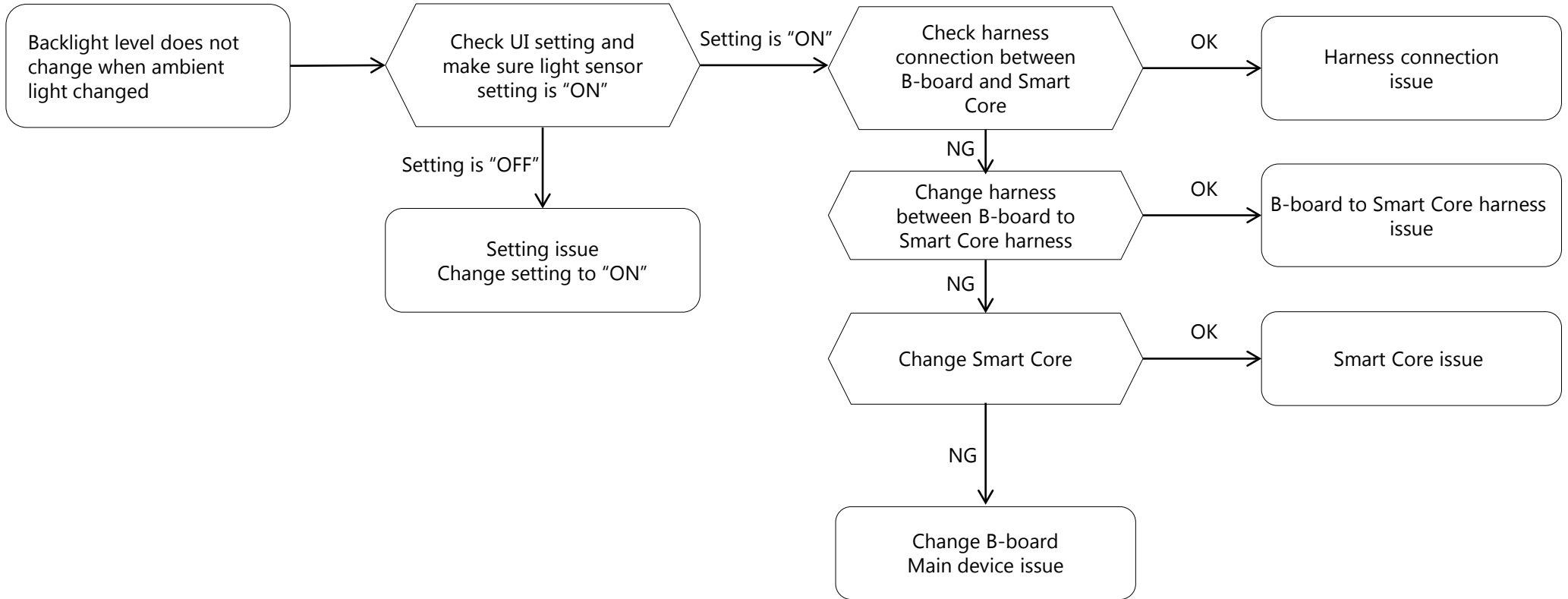

## 6.0 Network Malfunction: Ethernet (Wired)

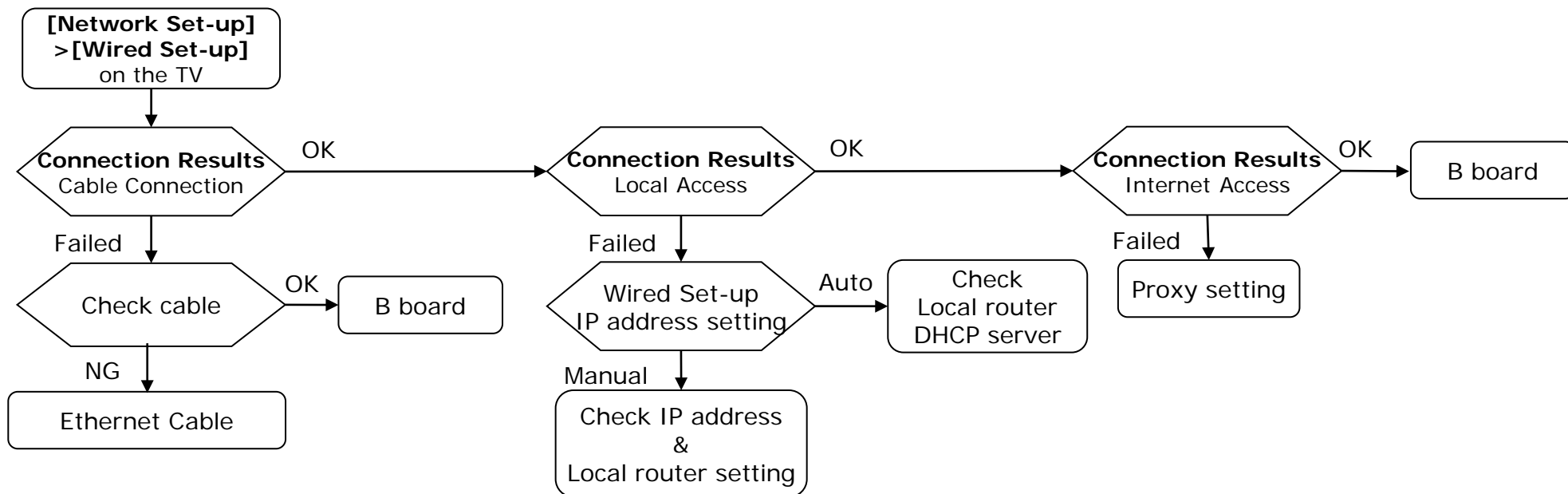

### B Board

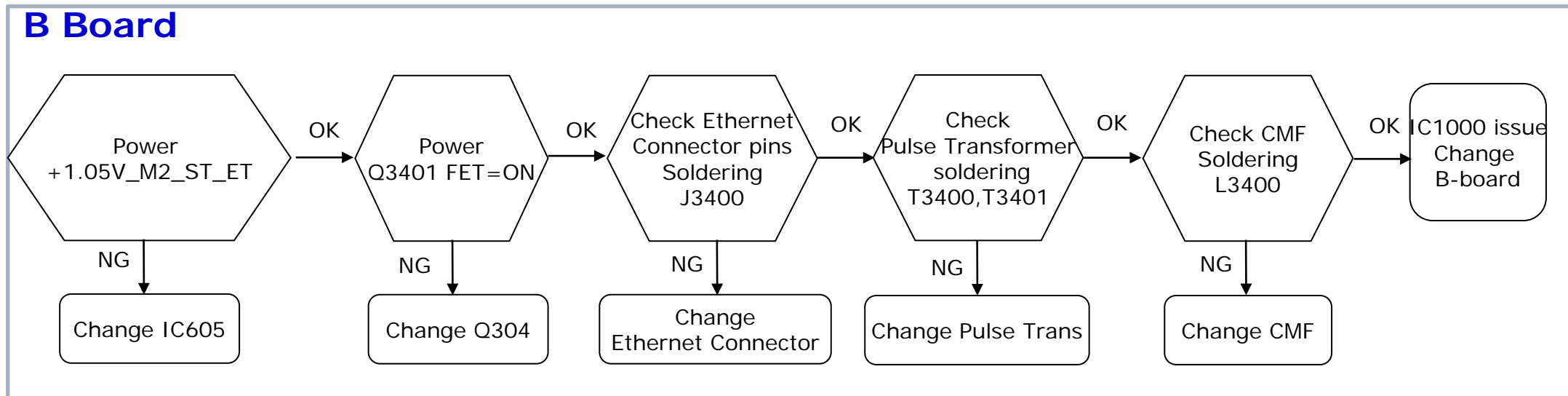

## Wireless Network malfunction (1/2)

## 1) Internal Wireless Network malfunction

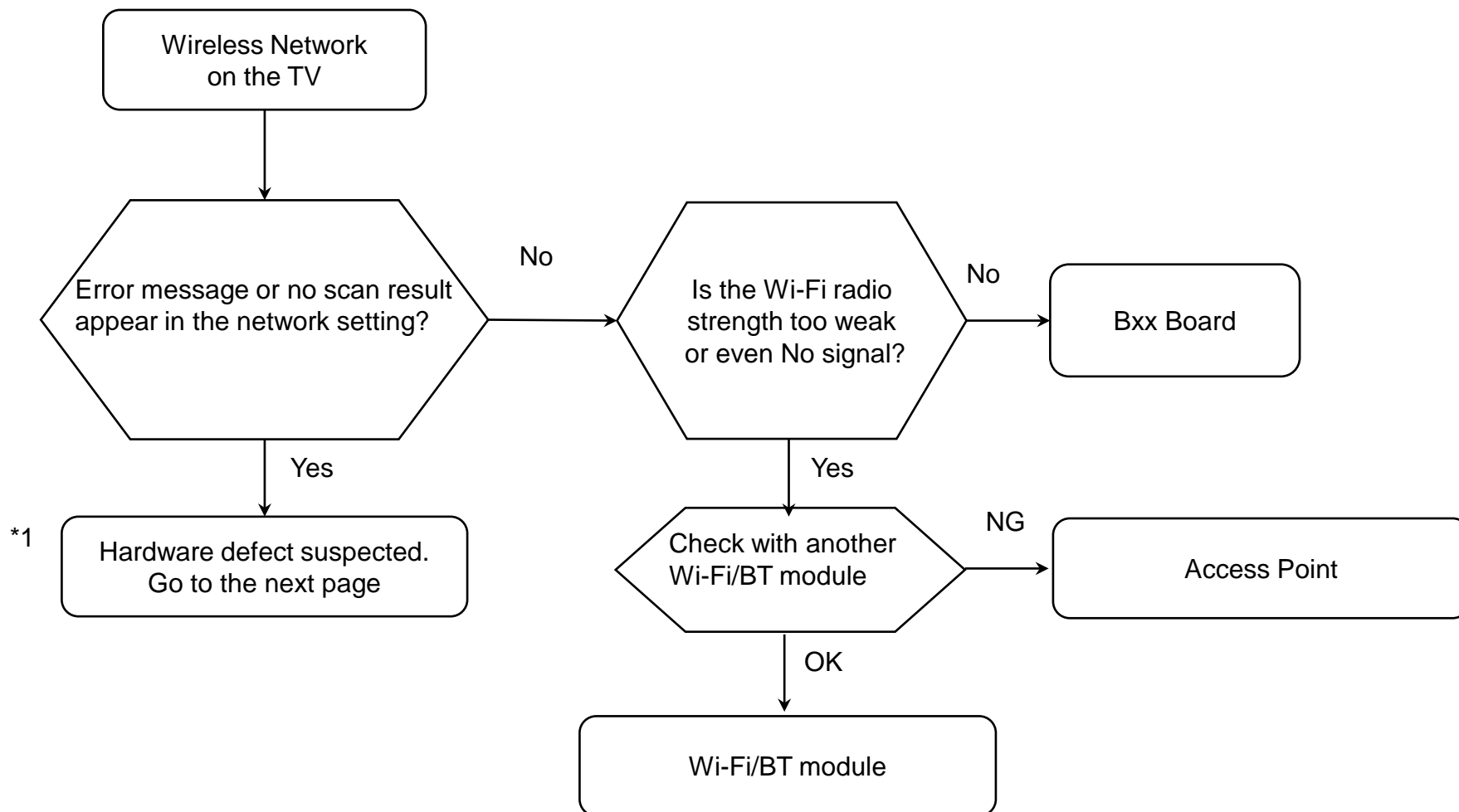

## Wireless Network malfunction (2/2)

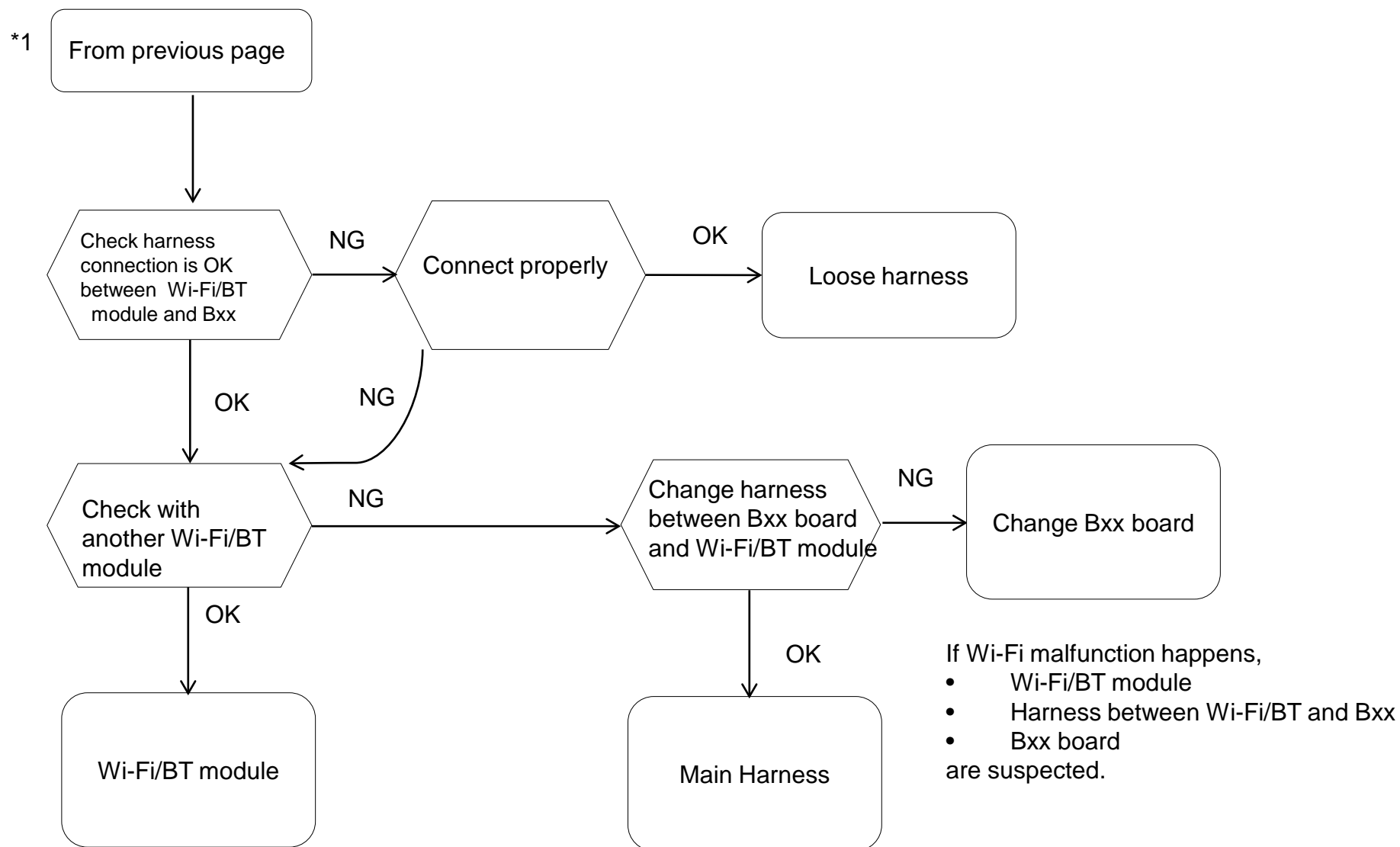

# Bluetooth malfunction

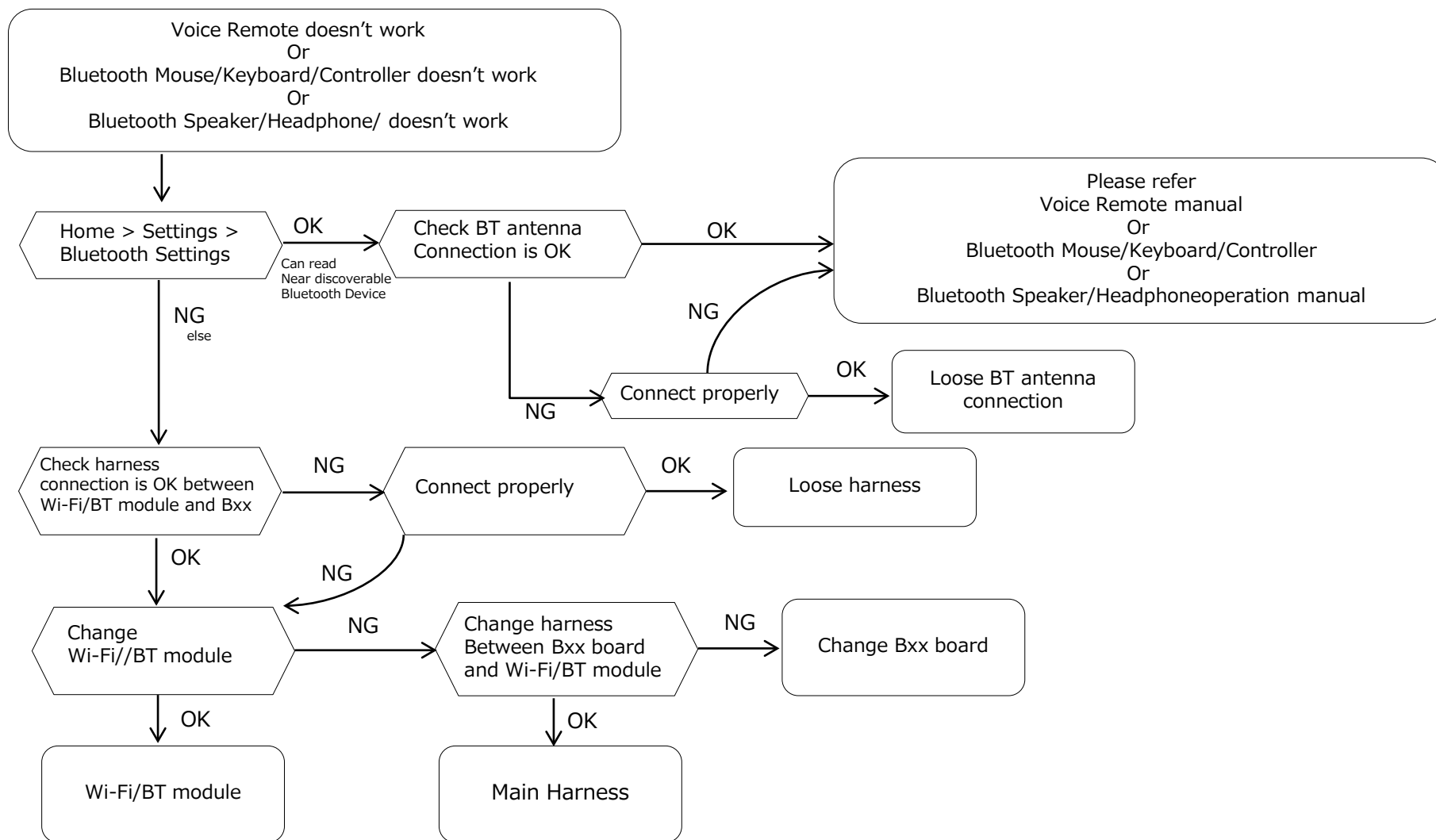

## SECTION 4 SERVICE ADJUSTMENT

When finished the operation of service mode , please AC Plug OFF/ON the TV set

\*If you don't do AC plug OFF/ON, remain the Service Mode App and user can see the Service Mode after RC ON.

### 4.1 How to Enter Service Mode

From Standby Mode

1. Go to TV standby condition by remote commander.
2. Press "Display or i+ (info)", "5", "Volume+" then "TV power" on remote.
3. You can see Service menu on display.

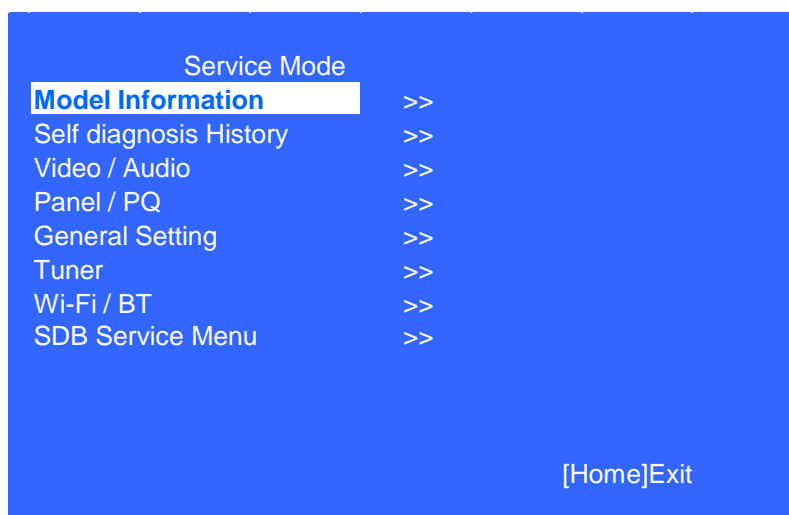

#### Summary of Service Control

Function	The flow of control
Service mode on	<Display or i+ (info)> <5> <Vol. Up> <Power>
Close Service menu	<Home>
Service mode off	AC plug OFF
Item up / down	<↑> / <↓>
Item select left/right	<←> / <→>
Execute	<Enter>

## 4.2 Software Version

1) In Service Mode, select “Model Information”, press “Enter” or → button to enter **Status Information**



2) Press “Enter” or “BACK” button to return to Service Mode

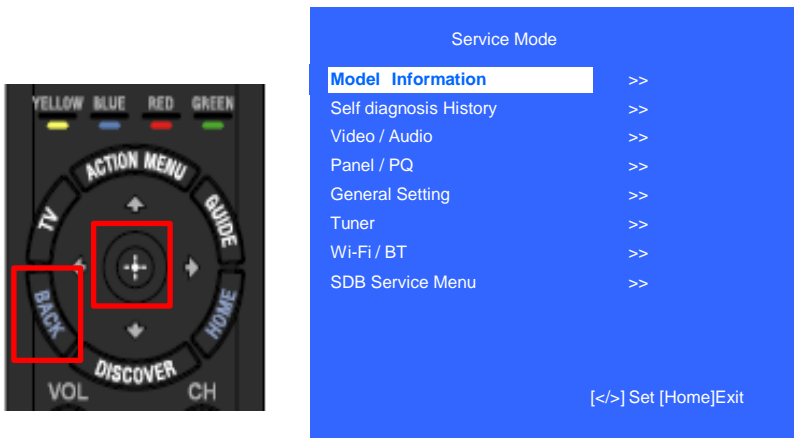

### 4.3 Serial Number Edit (1)

- 1) In "Service Mode", select "Model Information" by pressing "↑" or "↓" then pressing "Enter" or "→" button to enter inside.
- 2) Select "Serial Number Edit" by pressing "↑" or "↓" button then pressing "→" button
- 3) Press "↑" or "↓" to input numbers
- 4) After user input data , press <Enter>
  - Pop-up dialog appear to confirm input data correct
  - **Serial Number can be set ONLY ONCE**
- 5) Press "→" or "←" button to select YES or NO. Select YES if input data is correct. Select NO if input data is incorrect. Press <Enter> to save answer.
  - \* The font color of YES/NO is change to black when it is selected.

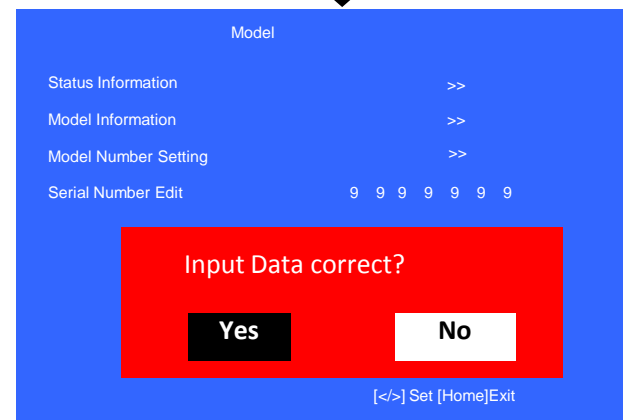
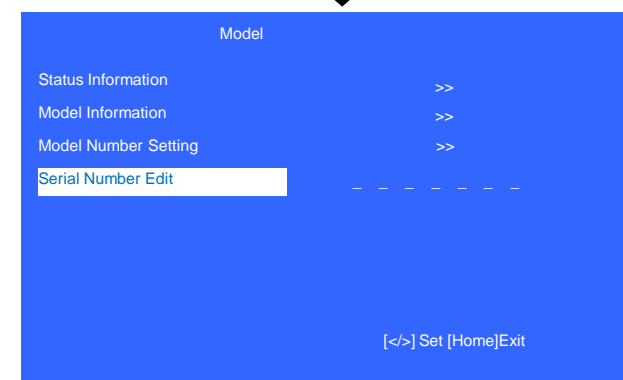
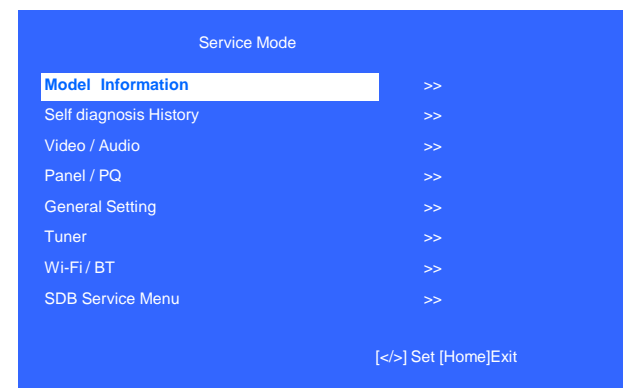

## 4.3 Serial Number Edit (2)

If **YES is selected**, the input data is saved into EEPROM. SERIAL NUMBER EDIT is greyed out and the serial number that has been input is displayed. Operator will **not able to edit** anymore.

If **NO is selected**, the input data is not saved into EEPROM. The serial number that has been input is displayed. Operator can still edit the Serial Number.

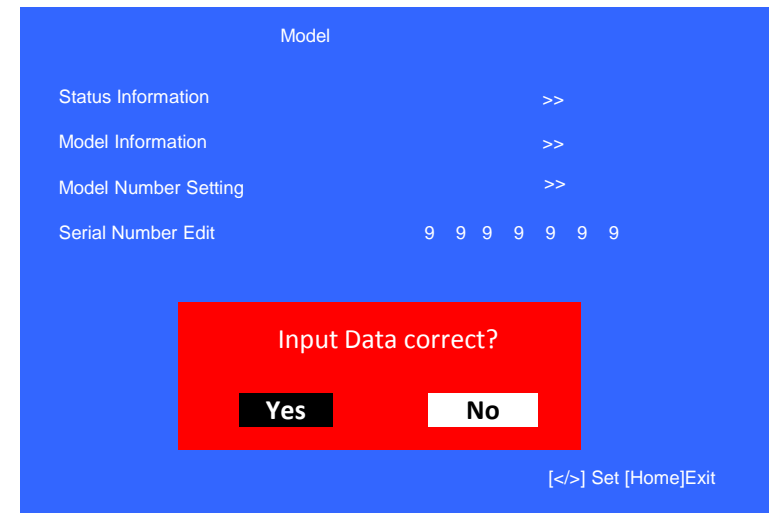
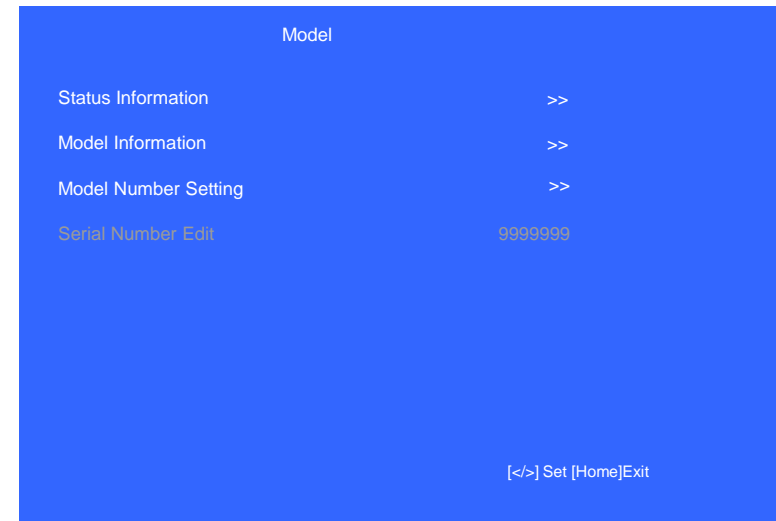

\*The font color of YES/NO is change to black when it is selected.

## 4.4 Model Number Setting

- 1) In "Service Mode", select "Model Information" by pressing "↑" or "↓" then pressing "Enter" or "→" button to enter inside.
- 2) Select "Model Number Setting" by pressing "↑" or "↓" button then pressing "Enter" or "→" button
- 3) Press "↑" or "↓" arrow key to scroll Product Name Candidate. (e.g. KD-65XF9005 CEI)
- 4) Select one Product Name from the list. After that select "[OK]" and press "Enter" button.

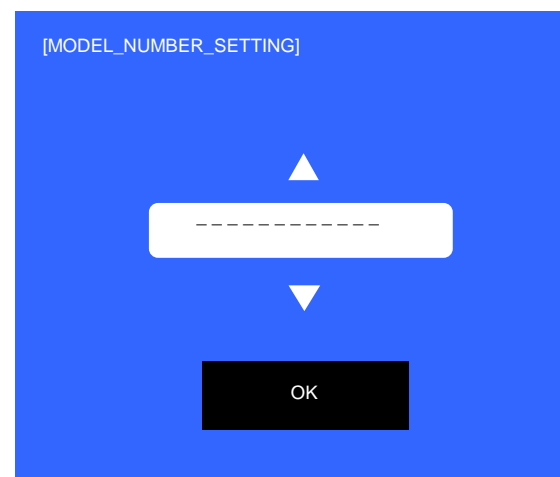
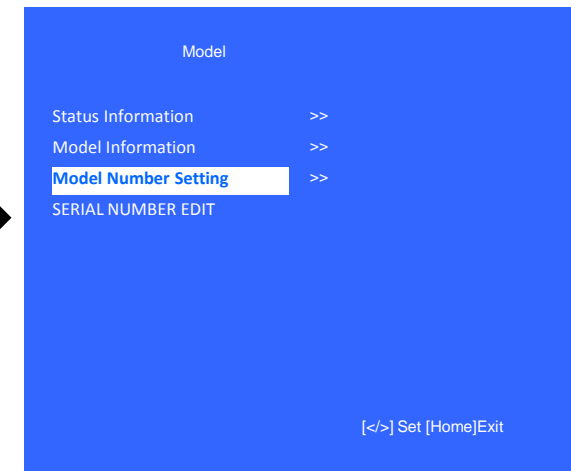
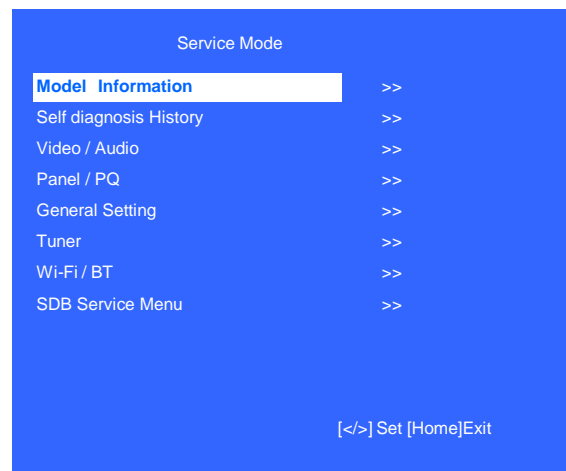

## 4.5 WB Adjustment (If necessary)

1. In “Panel/PQ” service mode
  - a. Go to “WB Adjustment” category by “↑” or “↓”.
  - b. To select “WB Adjustment”, press → button.
  - c. To change data , press “←” or “→” on remote commander.

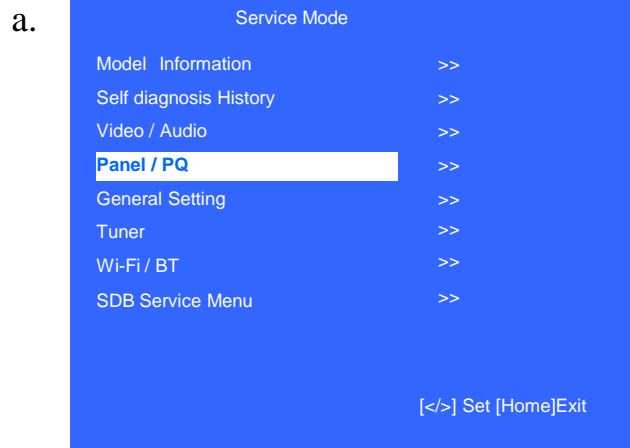
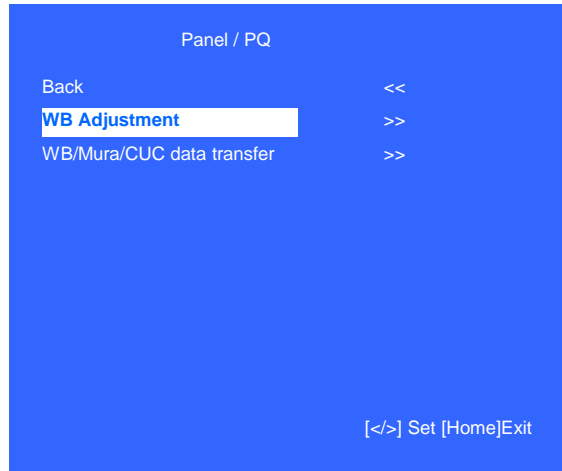
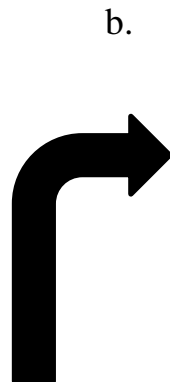

## 4.6 WB/Mura/CUC data transfer

Please apply Main board or panel is replaced.

1. In “**Panel/PQ**” service mode
  - a. Go to “**WB/Mura/CUC data transfer**” category by “↑” or “↓”.
  - b. To select “**WB/Mura/CUC data transfer**”, press → button.
  - c. To change data , press “←” or “→” on remote commander.

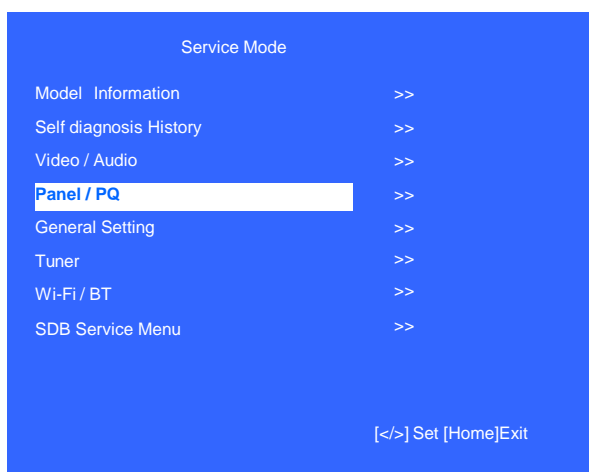
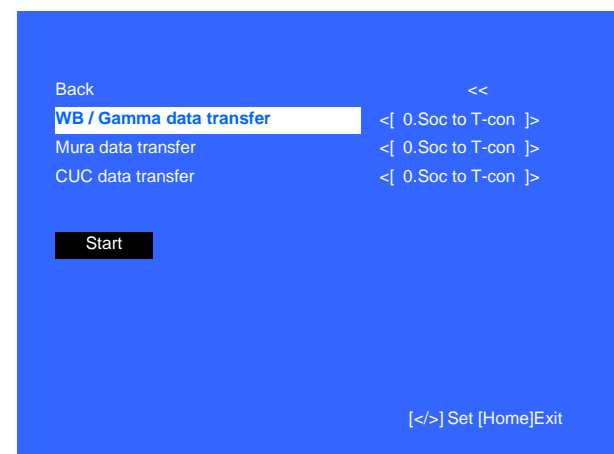
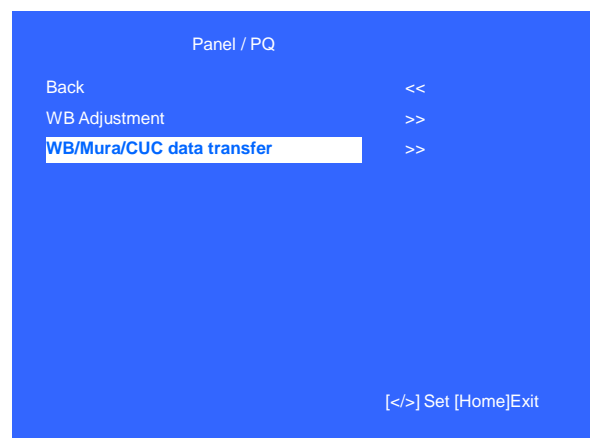
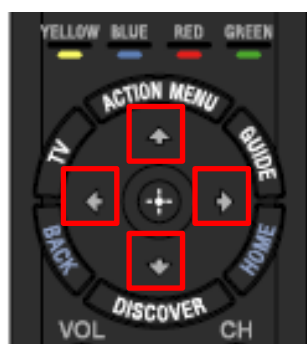

2. In “**WB/Mura/CUC data transfer**”
  - a. Select “**WB/Gamma data transfer**” by pressing “↑” or “↓” on remote commander .
  - b. To change the items, press “←” or “→” on remote commander and press “Enter” button.  
Selectable items are:
    - 0. SoC to T-con
    - 1. T-con to SoC
    - 2. Not action
  - c. Similarly, to select the items in Mura and CUC data.
  - d. Select “[start]” and press “Enter” button to start transfer.

## 4.7 HDD Performance Check (EU only)

- 1) In "Service Mode", select "General Setting" by pressing "↑" or "↓" then pressing "Enter" or "→" button to enter inside.
- 2) Select "HDD Performance check" by pressing "↑" or "↓" then pressing "Enter" or "→" button to enter inside.
- 3) A message "Please wait ..." is displayed during performance check processing.
- 4) Result **OK** or **NG** will be displayed after performance of HDD is checked

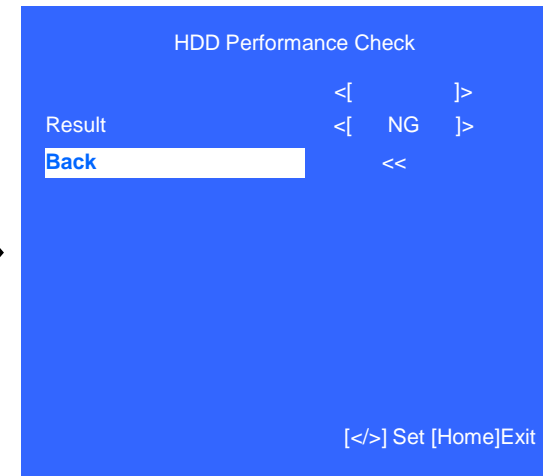
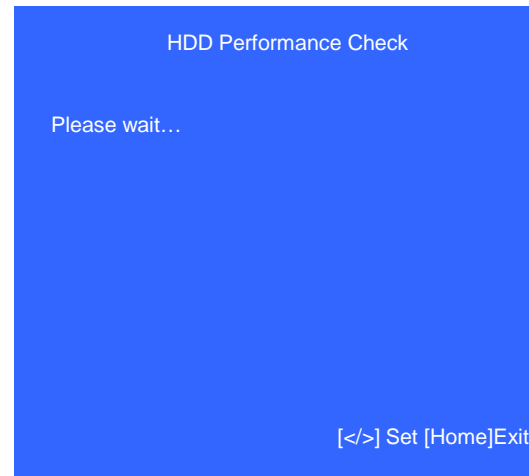
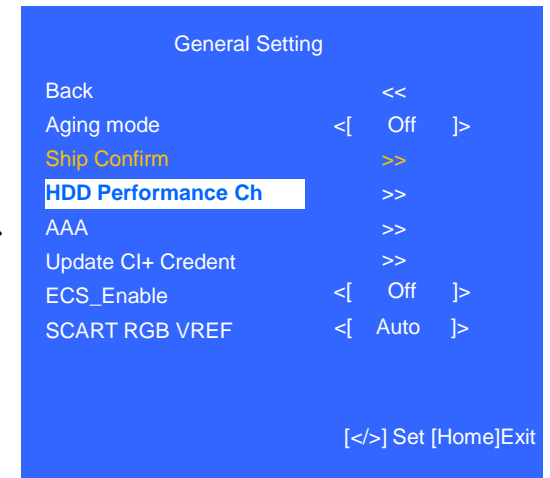
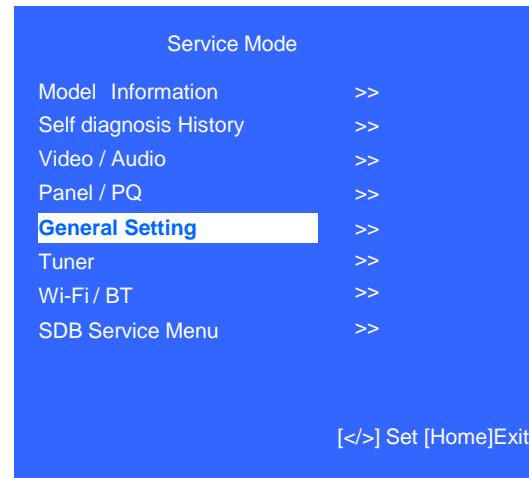

## 4.8 HDD Re-Register (EU only)

- 1) In "Service Mode", select "General Setting" by pressing "↑" or "↓" then pressing "Enter" or "→" button to enter inside.
- 2) Select "AAA" by pressing "↑" or "↓" then pressing "Enter" or "→" button to enter inside.
- 3) Result **OK** or **NG** will be displayed after HDD re-registration is succeed/failed

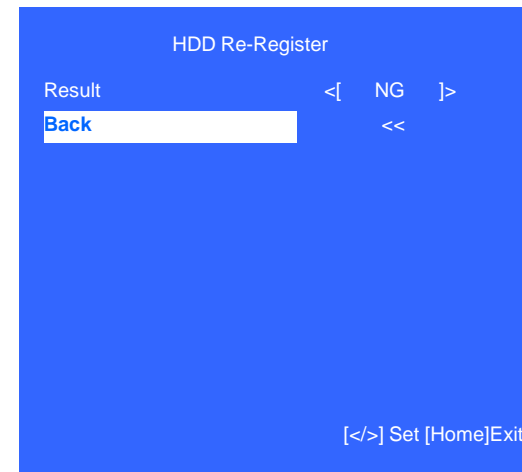
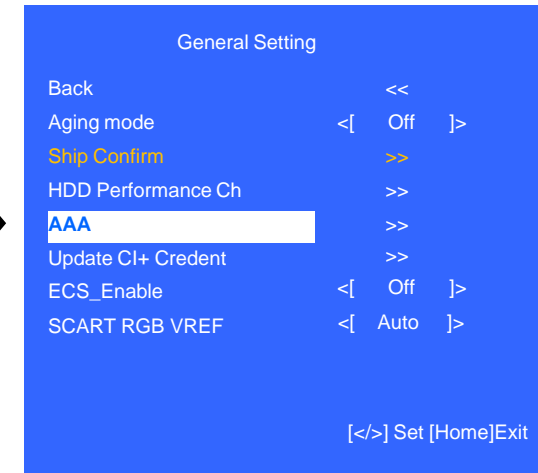
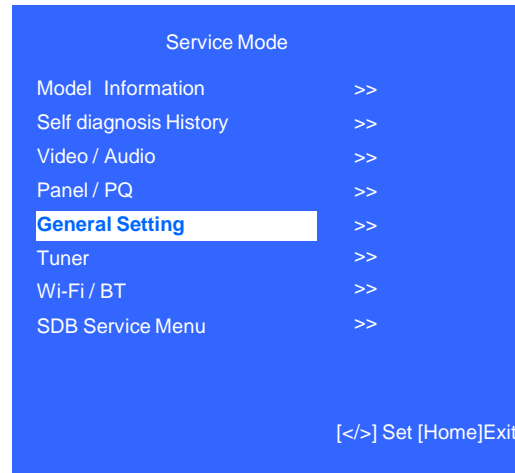

# USB Update

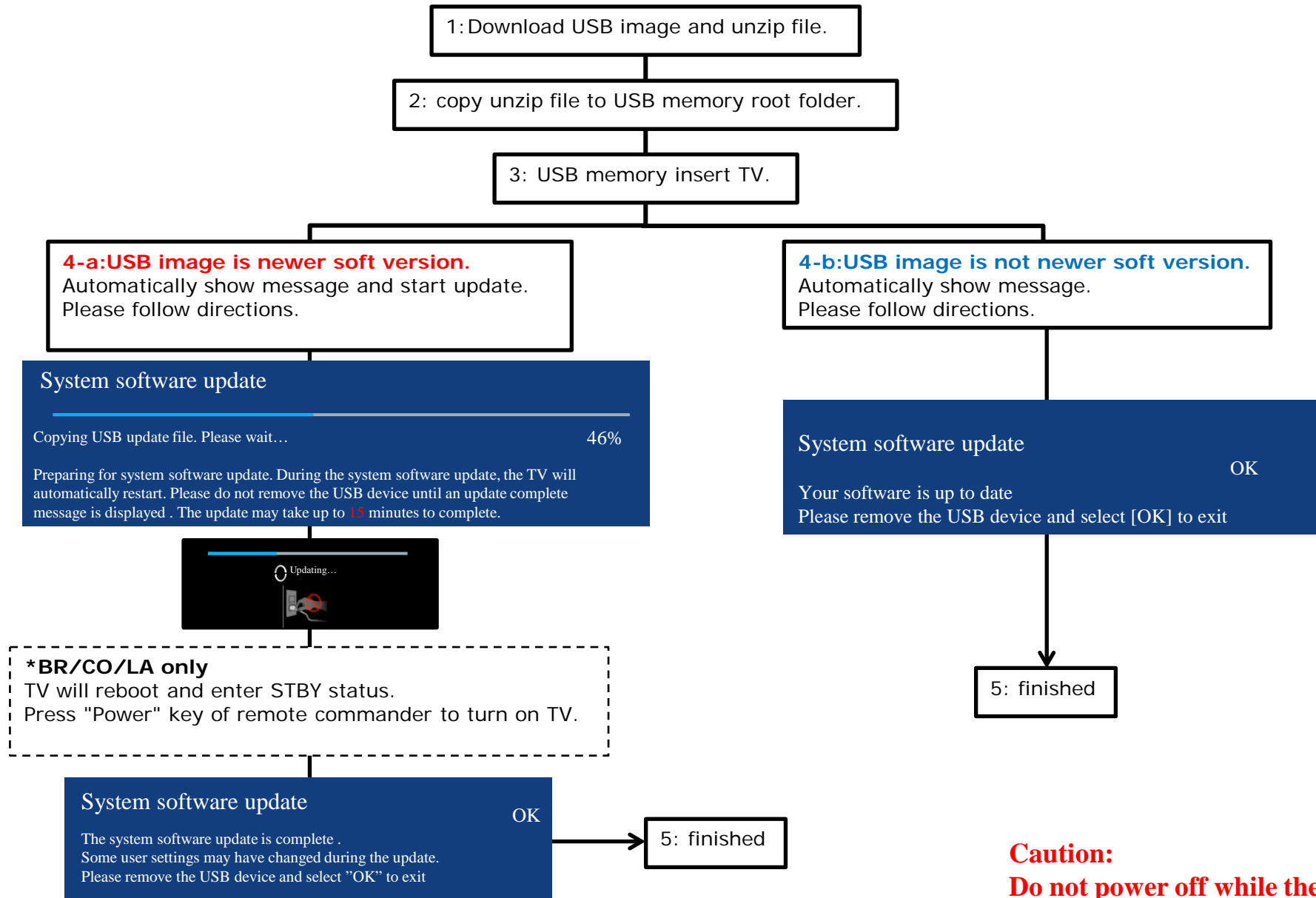

**Caution:**  
Do not power off while the update is in progress.

## SECTION 5 DIAGRAMS

### 5.1 Block Diagram

\* depend on destinations

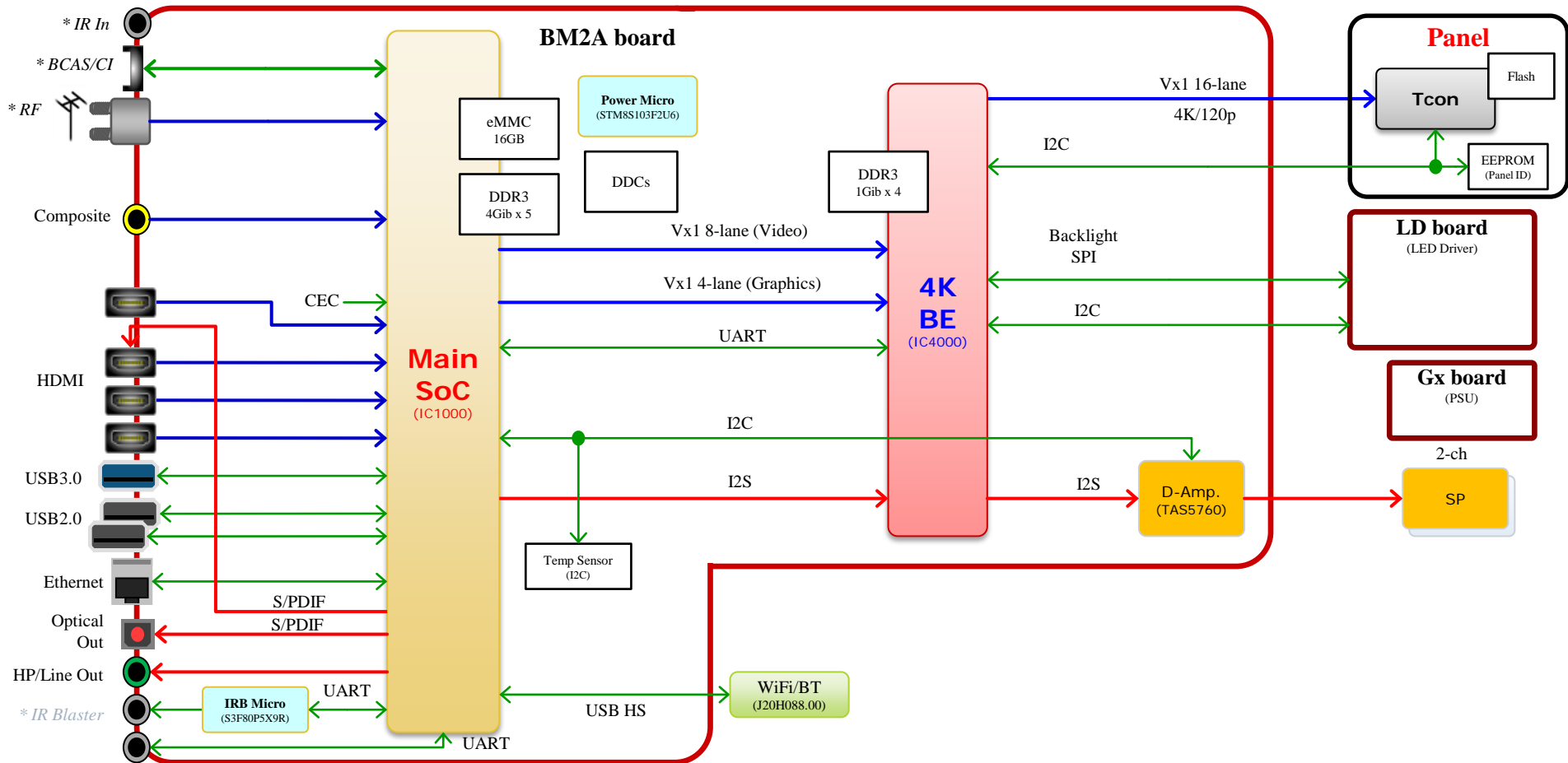
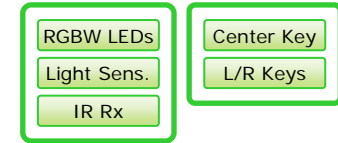
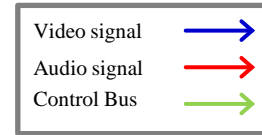

## 5.2 Connector Diagram

CU 49"

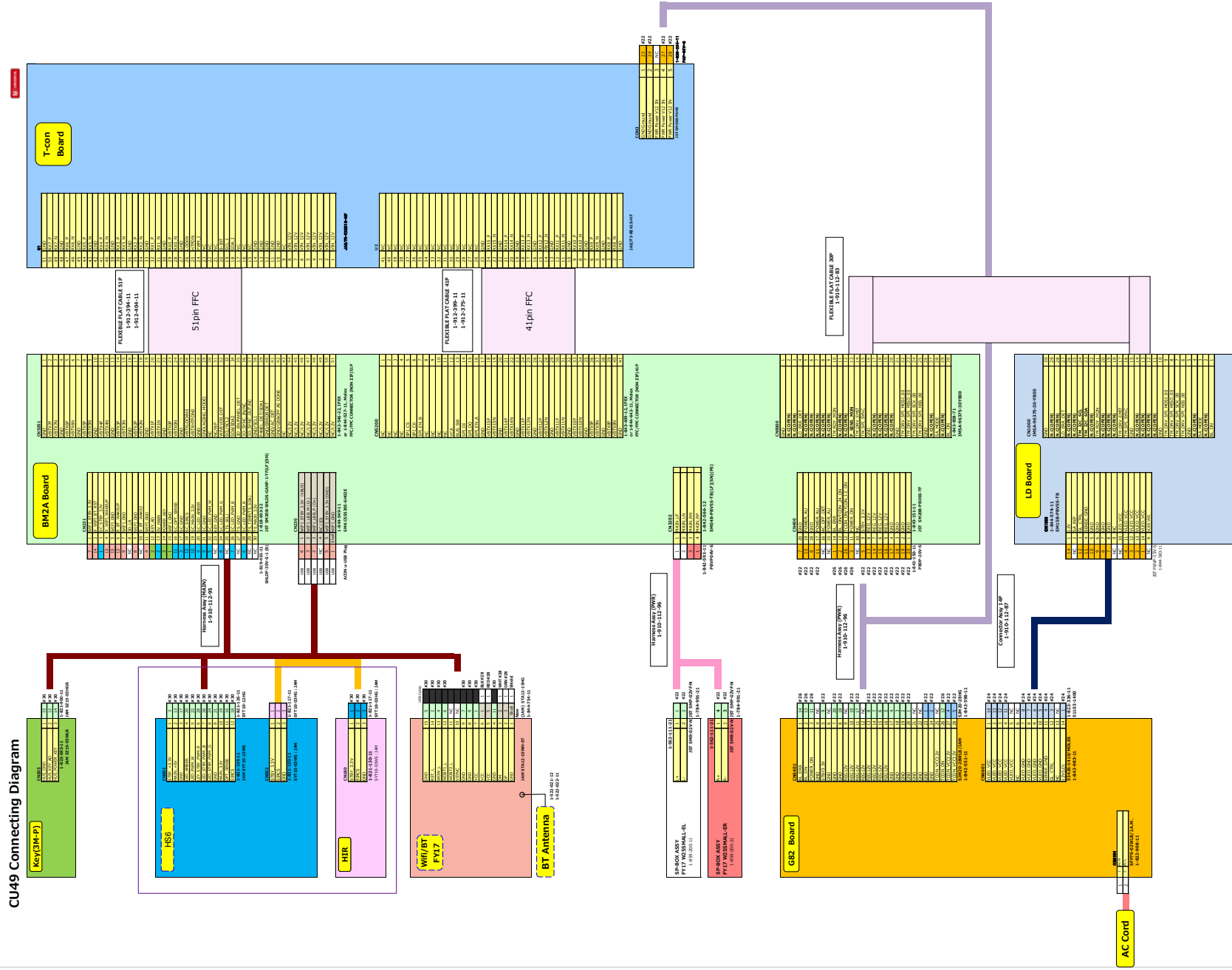

# CU55" (except SBR model)

CU55 Connecting Diagram

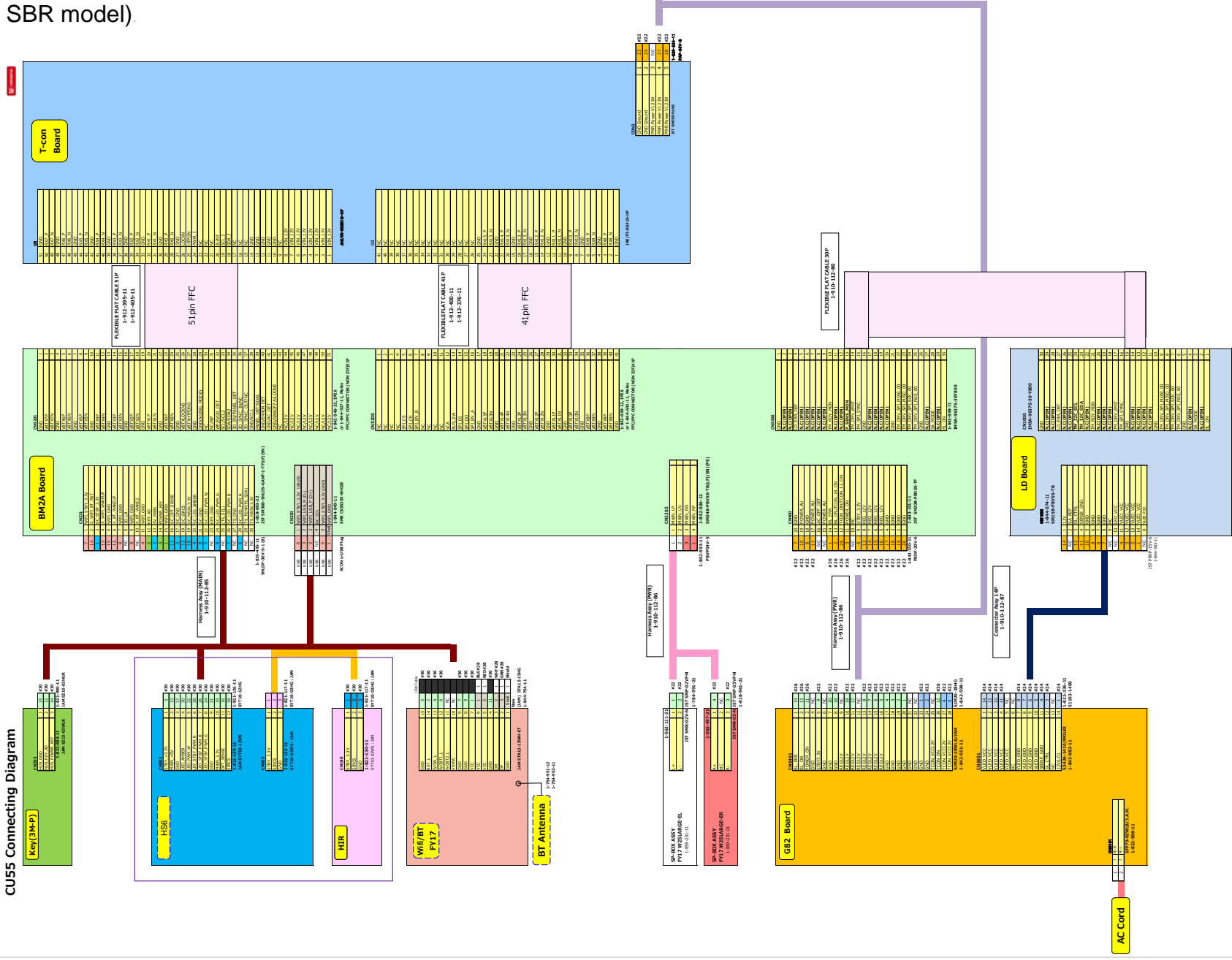

CU 55" (for SBR model)

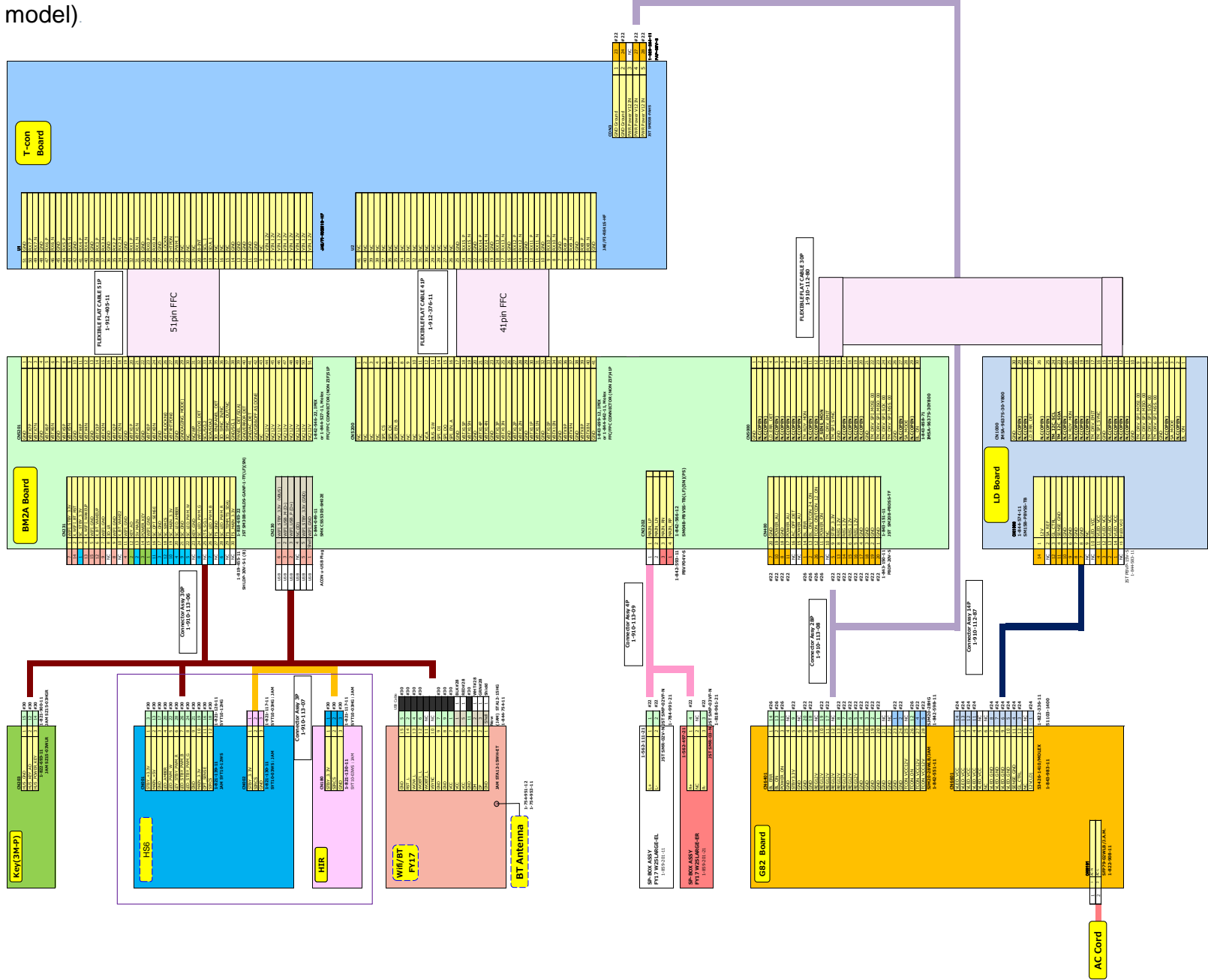

# CU65" (except SBR model)

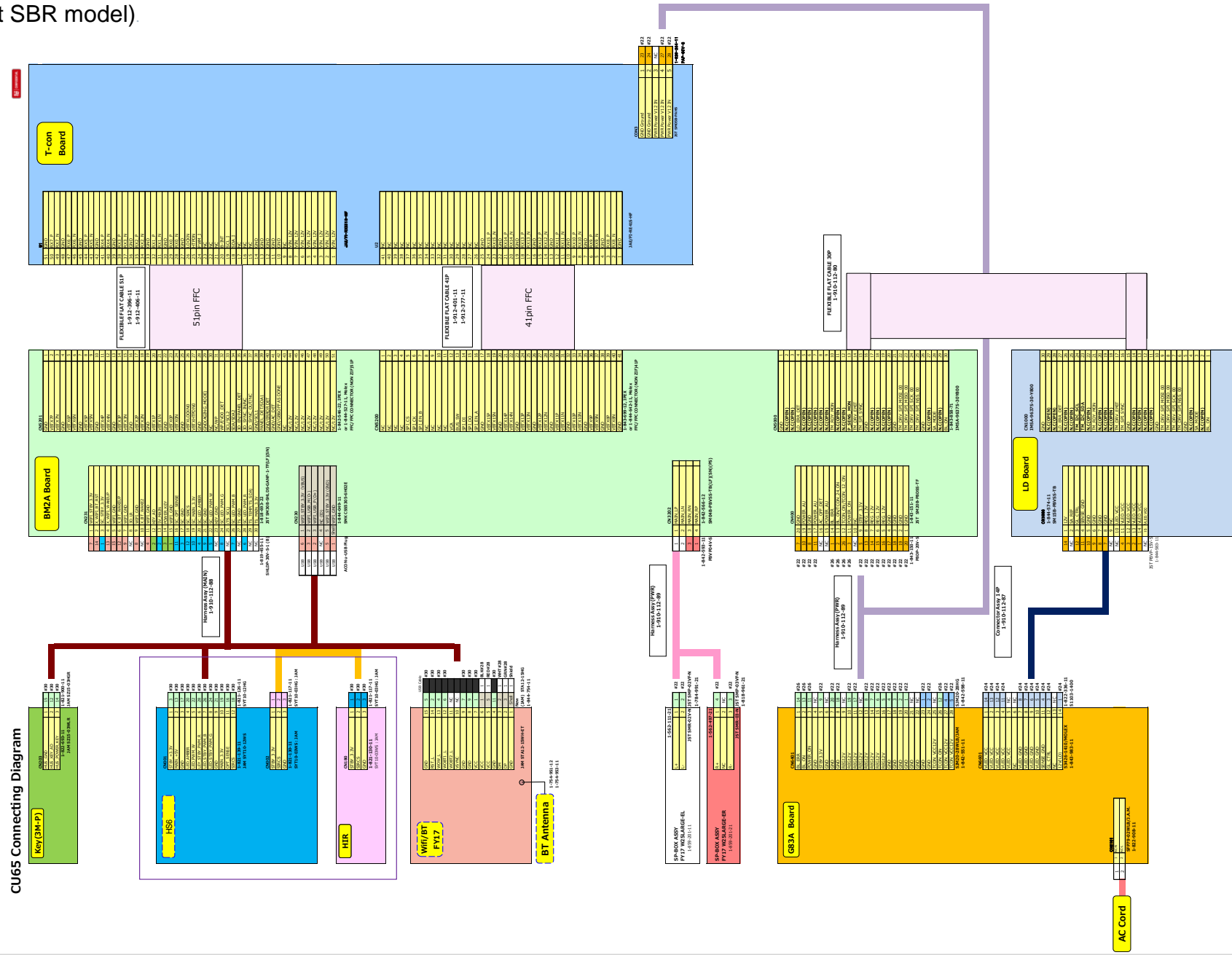

CU 65" (for SBR model)

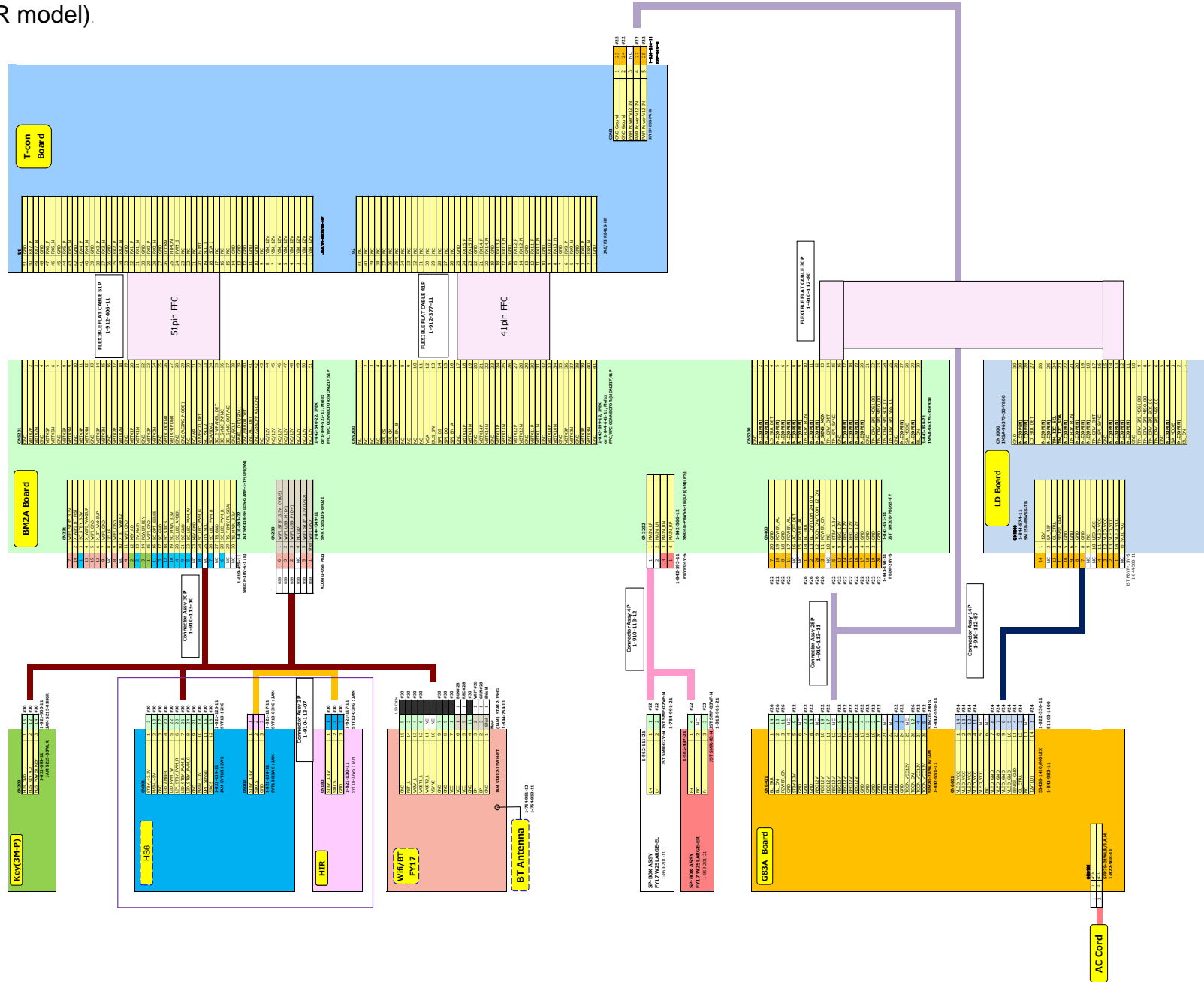

# CU 75" (except SBR model)

CU75 Connecting Diagram

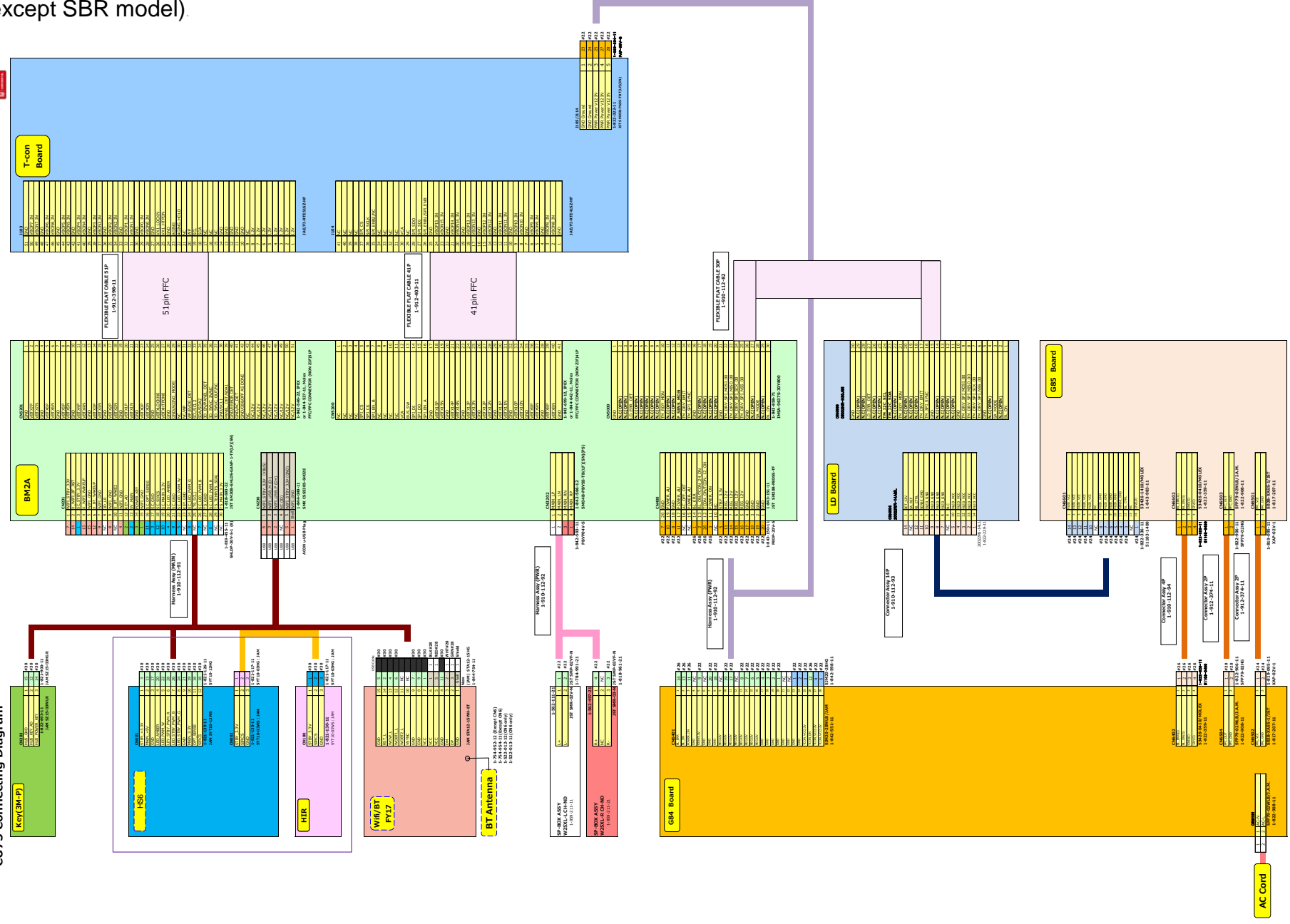

CU 75" (for SBR model)

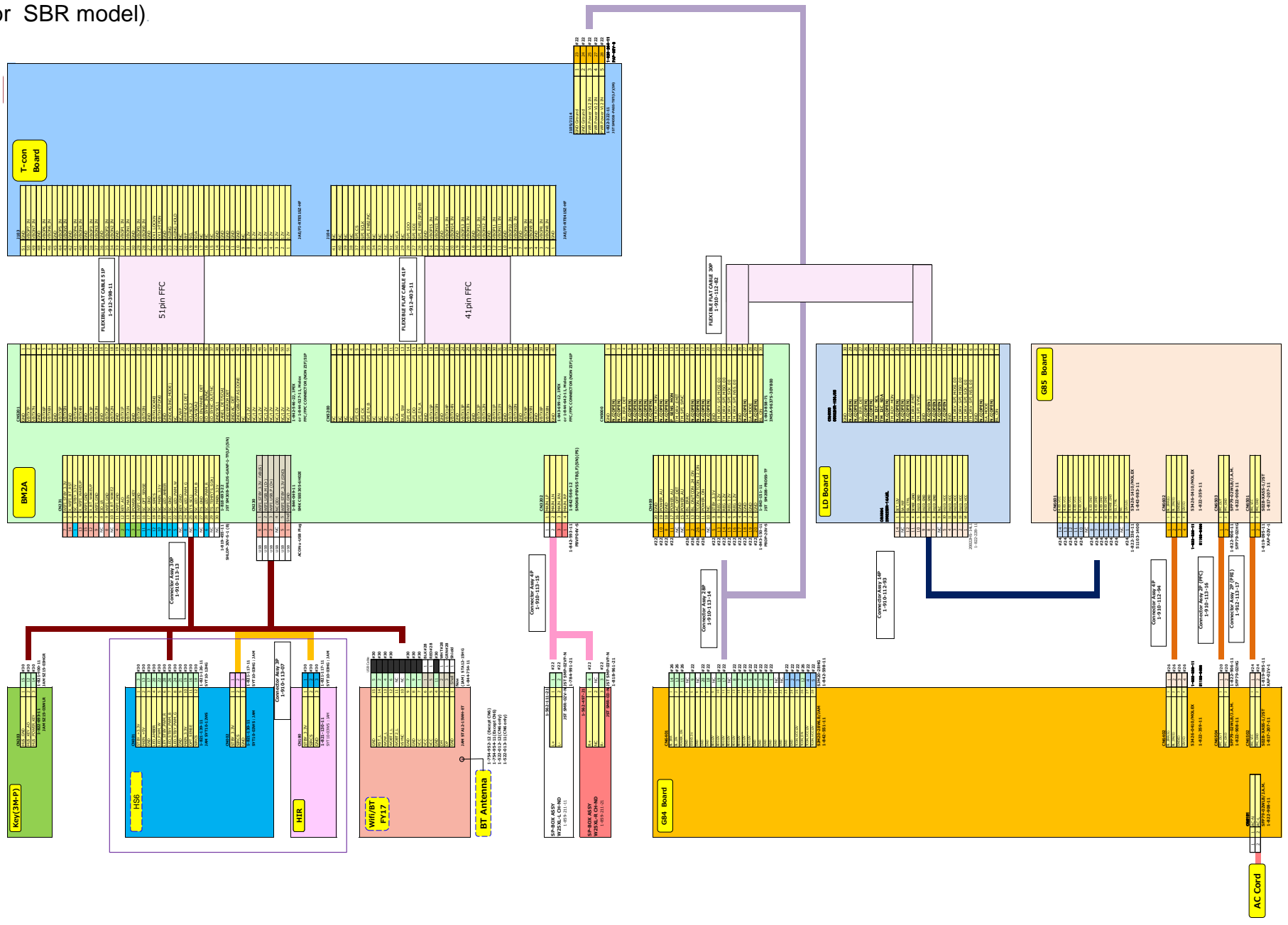



## SECTION 6 PANEL HANDLING

### 1. Unpacking

1. Take out panel from carton box by 2 operators.



2. Take out panel vertically from carton box.  
And do not hit other panel.

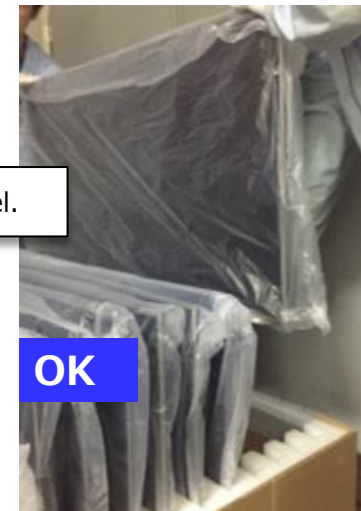
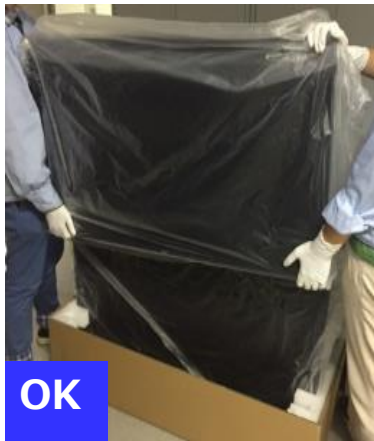

# 1. Unpacking

3. Please make protection for remaining modules to avoid abnormal hitting when take out modules.

Example:

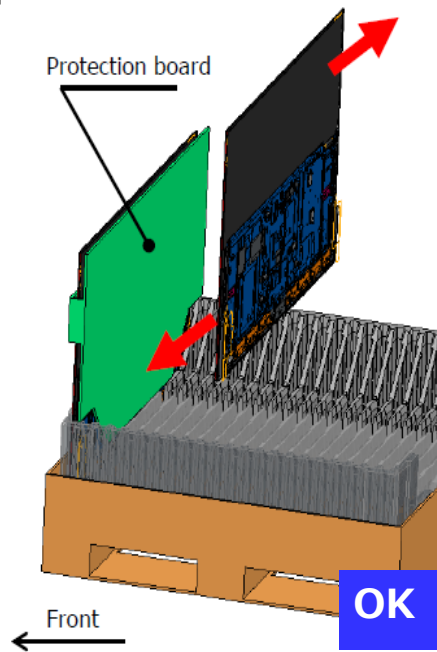

Protection board



Protection board



Front view

Protection board



Side view

## 1. Unpacking

4. Do not hold or press O-Cell.

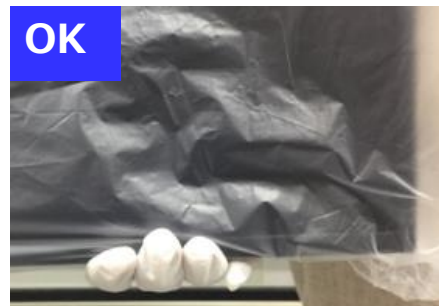

## 1. Unpacking

- Put on to table & remove the protection bag.

Caution: To avoid hitting the center area of bottom AL frame for smart core.  
Please prepare and use support cushion on both side as below.

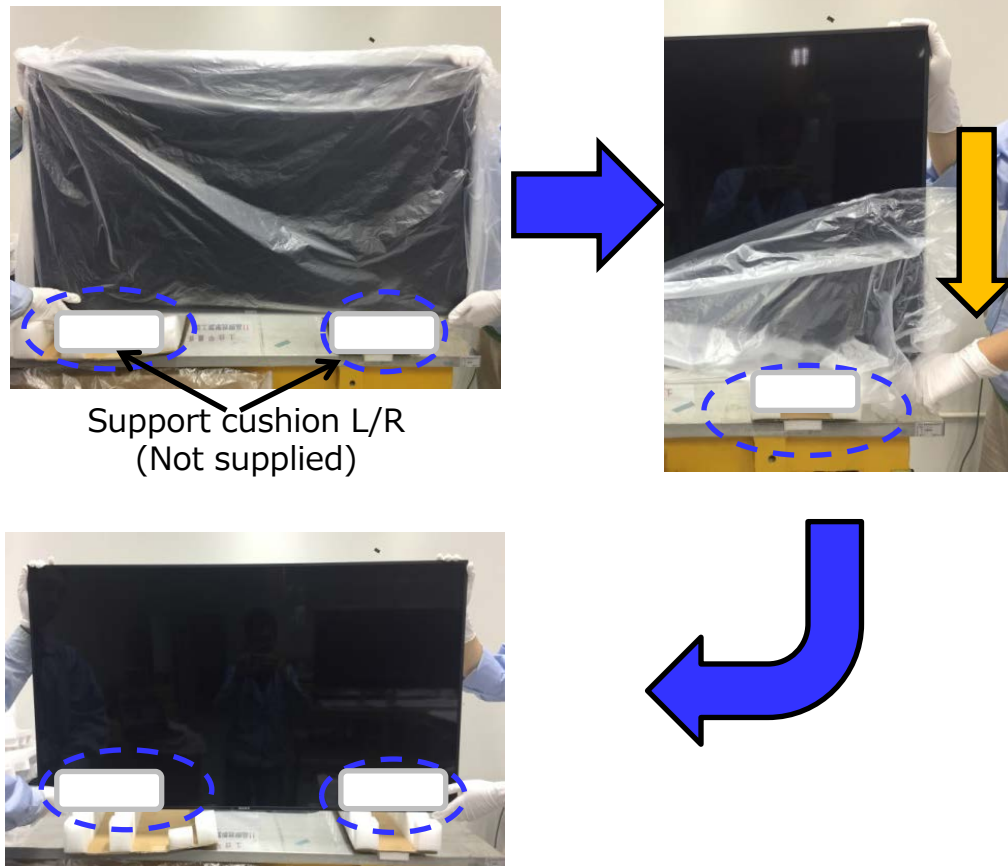

## 2. Carrying

1. Carry panel vertically.

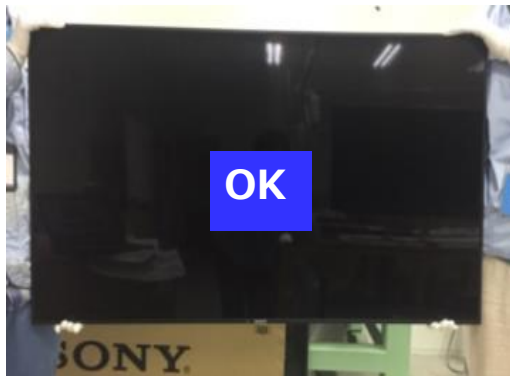

2. Do not hold or press O-Cell.

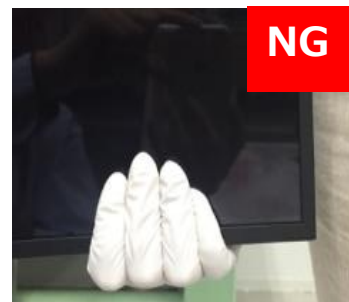
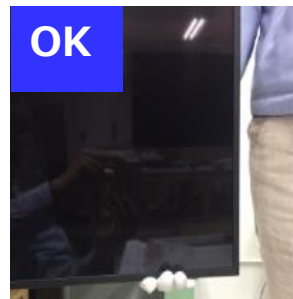
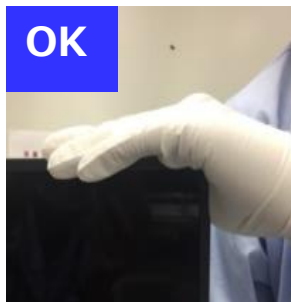

## 2. Carrying

3. Hold panel by 2 people.

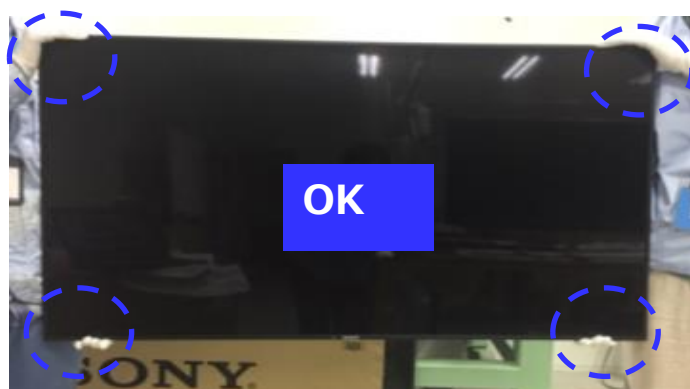

4. Do not hold the panel at the center area.

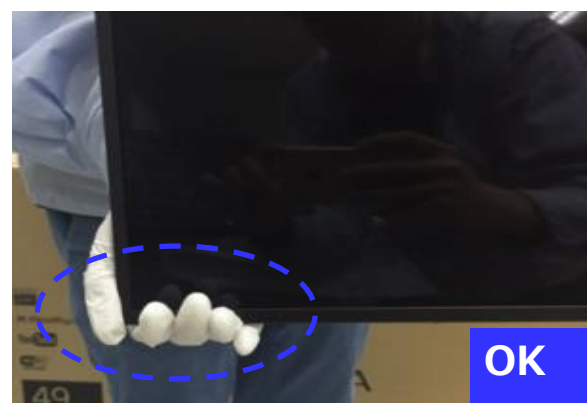
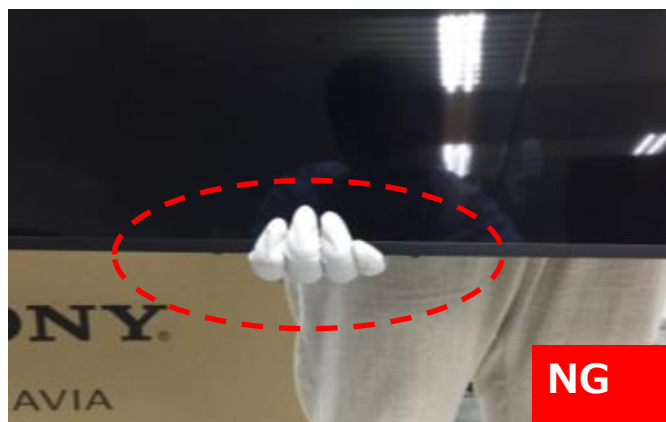

### 3. Placing to table

1. Put the Panel by 2 operators.

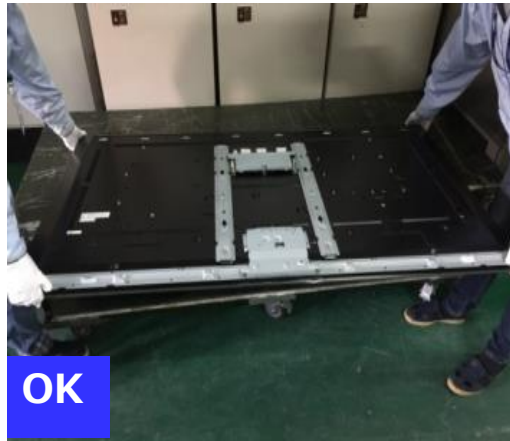

Holding corner



2. Put the Panel within one flat table surface.

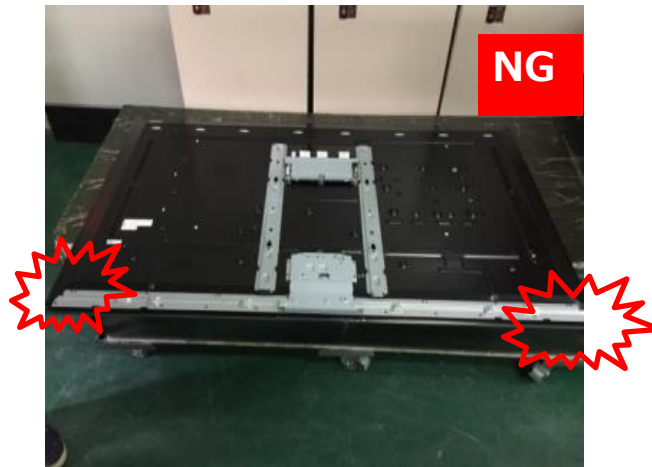

#### 4. Other

1. Do not press the panel during assembly and disassembly.



2. Do not touch Panel module without gloves.

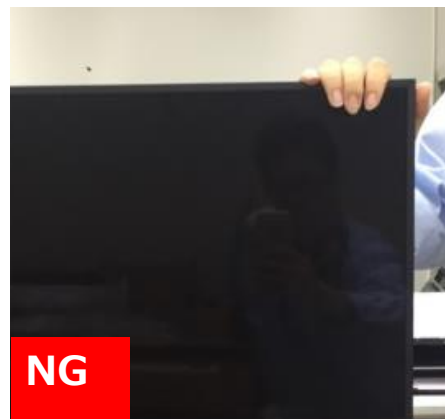
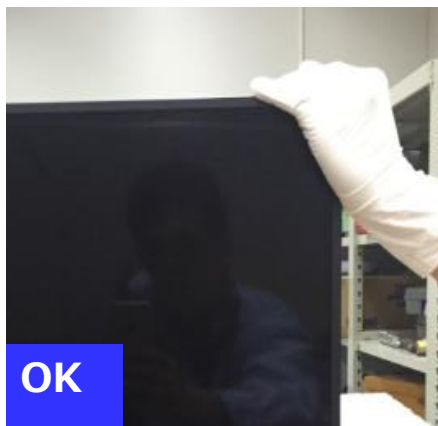

#### 4. Other

3. Do not grasp Source Shield.



4. Do not grasp the BC hook.



5. Do not grasp the LD Shield.



## SECTION 7 G\* BOARD HANDLING

### How to disassemble G810 and G811A for CU85

○ : screw

□ : earth clip

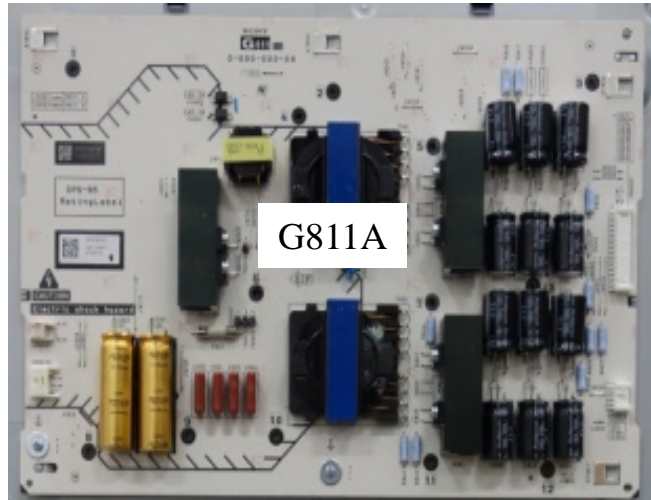

Removing screw

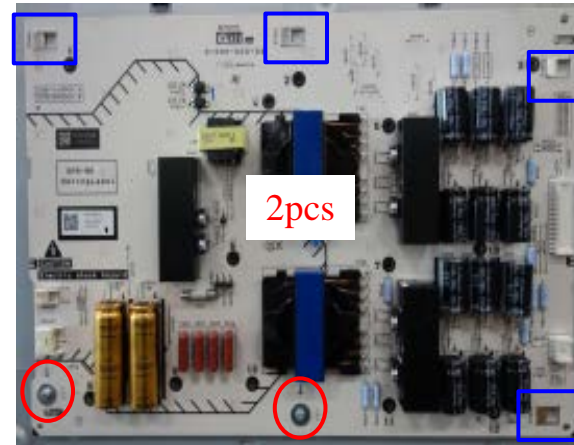

Continued on  
the next page

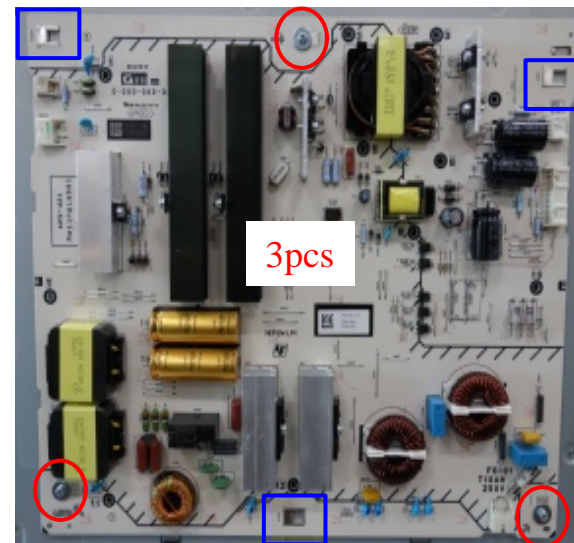
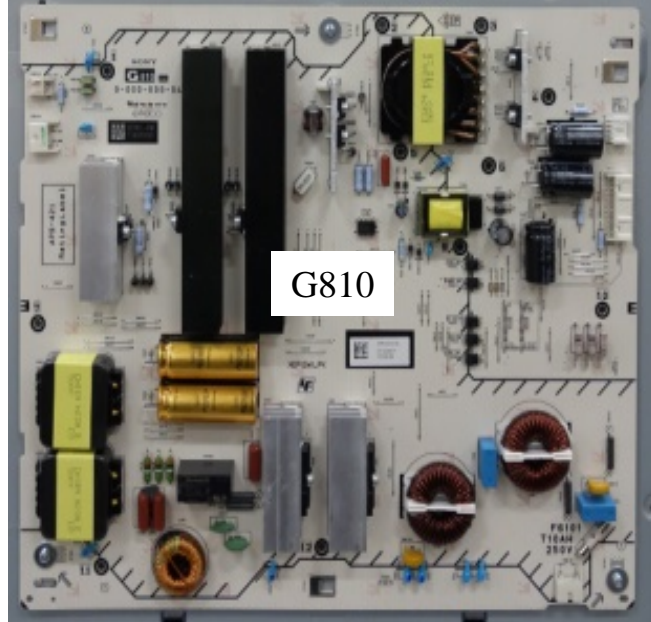

Continued on  
the next page

### Disassembly G811A

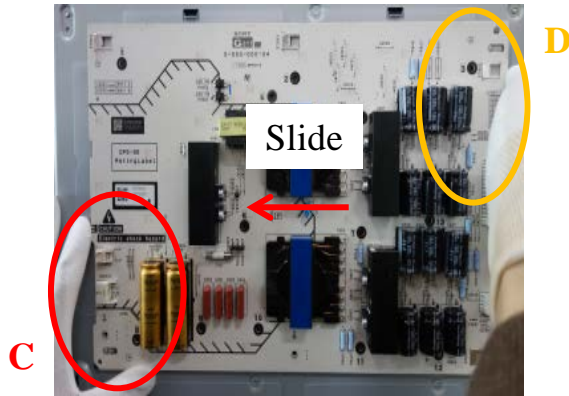

**SUPPORT**

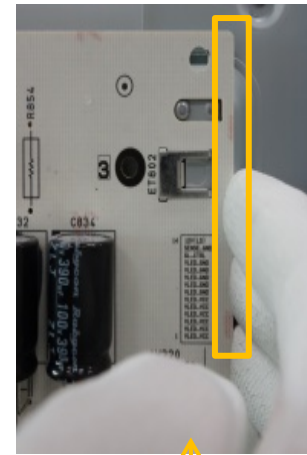

**PUSH**

Support board  
To avoid hitting M't parts on B-side  
due to excess-slide and falling  
board during standing position  
Support position :  
Board edge(RED line)

Push board  
To disassemble board  
Push position :  
Board edge near earth clip  
(orange area)

Continued on the next page →

### Disassembly G810

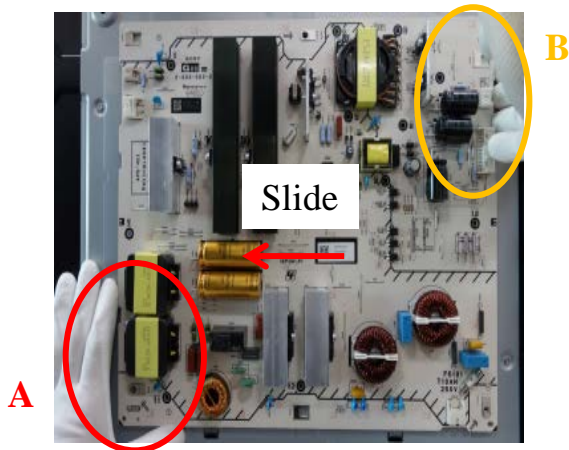

**SUPPORT**

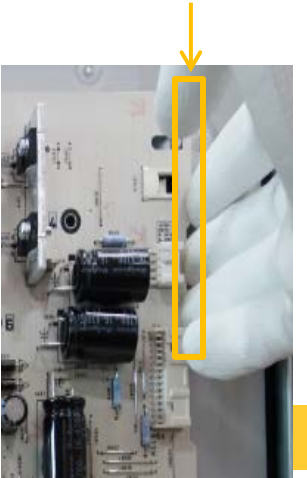

**PUSH**

Continued on the next page →

G811A

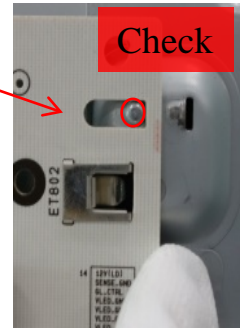
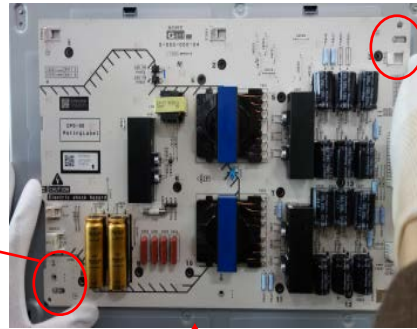

Disassembly

Disassemble board with These conditions after slide

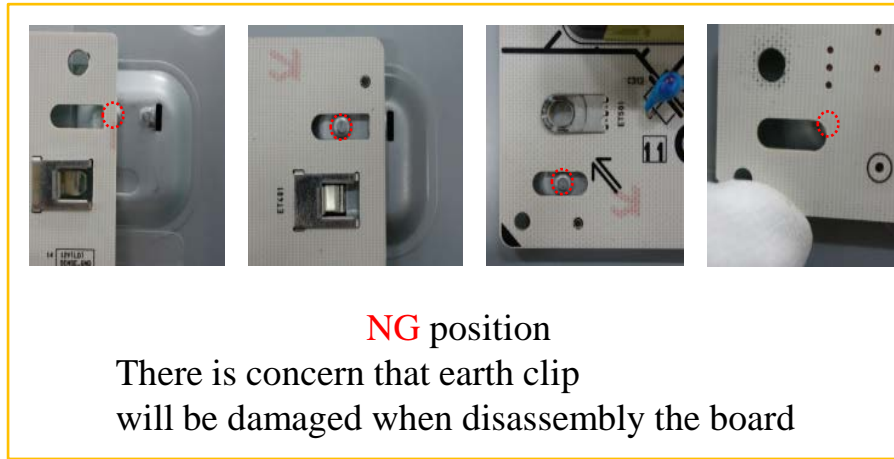

G810

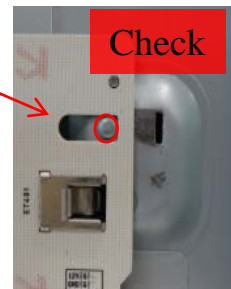
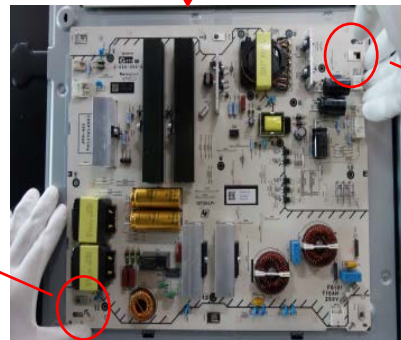
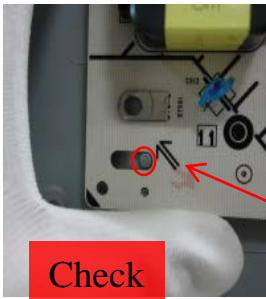

Disassembly

## Handling Caution G810 and G811A for CU85

This caution is standard request but especially important for G810 and G811A to avoid deformation of earth clip

G811A

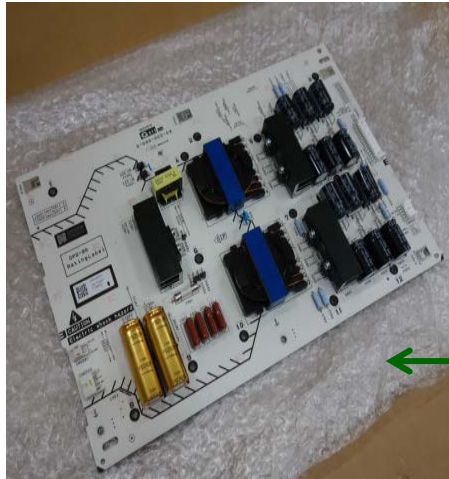

G810



When placing the board, should place on the **soft cloth etc.**

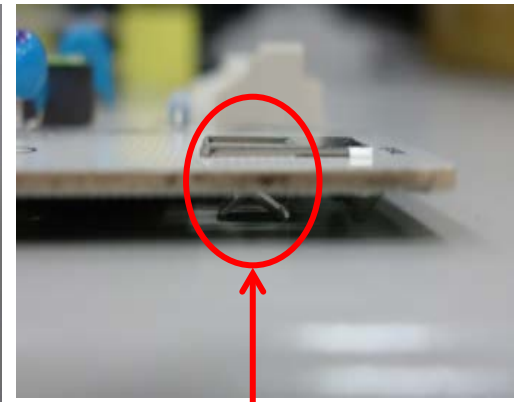

If the board is placed on the hard table, earth clip is damaged and deformed

