

MDR-Z1R

SERVICE MANUAL

Ver. 1.0 2016.09



*US Model
Canadian Model
AEP Model
UK Model
E Model
Australian Model
Chinese Model
Tourist Model*

SPECIFICATIONS

Type: Closed, dynamic (circum-aural) / **Driver unit:** 70 mm, dome type (CCAW Voice Coil) / **Power handling capacity:** 2,500 mW (IEC*) / **Impedance:** 64 Ω at 1 kHz / **Sensitivity:** 100 dB/mW / **Frequency response:** 4 Hz - 120,000 Hz / **Mass:** Approx. 385 g (14 oz) without cable / **Included items:** Stereo headphones (1), Headphone cable (Approx. 3 m (118 1/8 in), silver-coated OFC strands, gold-plated stereo mini plug) (1), Balanced-connection headphone cable (Approx. 1.2 m (47 1/4 in), silver-coated OFC strands, Gold plated balanced standard plug) (1), Gold-plated unimatch plug adaptor (stereo phone plug \leftrightarrow stereo mini jack) (1), Hard case (1)

* IEC = International Electrotechnical Commission

Design and specifications are subject to change without notice.

STEREO HEADPHONES

SONY®

9-896-314-01

2016I33-1

© 2016.09

Sony Video & Sound Products Inc.

SECTION 1 SERVICING NOTES

The **SERVICING NOTES** contains important information for servicing. Be sure to read this section before repairing the unit.

NOTE OF REPLACING THE HEAD BAND ASSY

A serial number is marked on the slider of head band assy. Therefore, when the head band assy is replaced, the serial number changes.

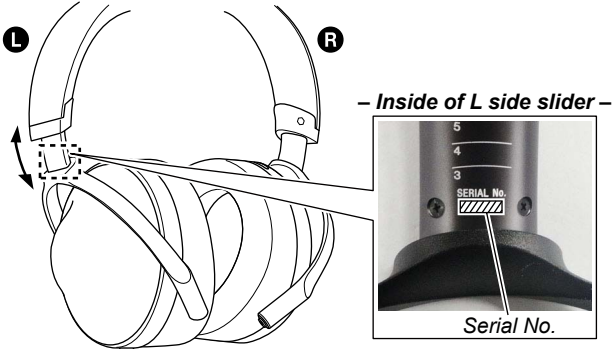

NOTE OF REPLACING THE HARD CASE ASSY

When replacing the hard case of supplied with the unit, remove the serial plate from the hard case of before replacing and attach that to the new hard case.

Note: The serial plate does not attached to the new hard case.

- ① Remove the serial plate from the hard case of before replacing.

Note: Serial plate is stuck with double-sided tape.

- Hard case of before replacing -

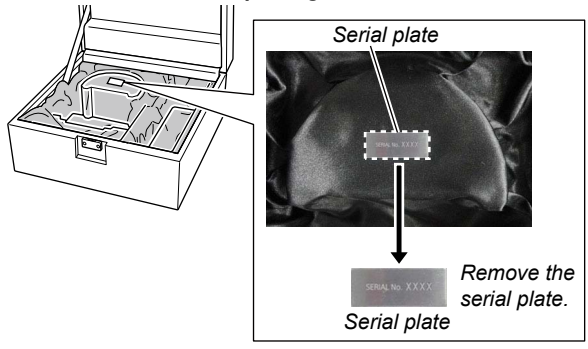

- ② Stick a double-sided tape of sold on the market so that not protrude from the outer shape of the serial plate.

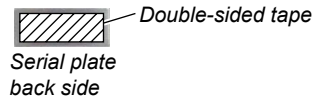

- ③ Attach the serial plate to the specified position of the new hard case.

- New hard case -

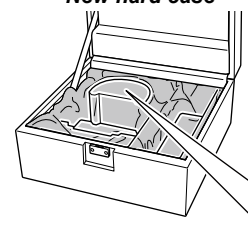

Attach the serial plate in the position shown in the following figure.

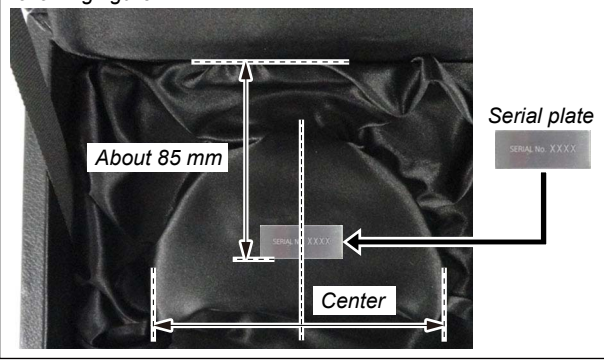

SECTION 2 DISASSEMBLY

- This set can be disassembled in the order shown below.

2-1. DISASSEMBLY FLOW

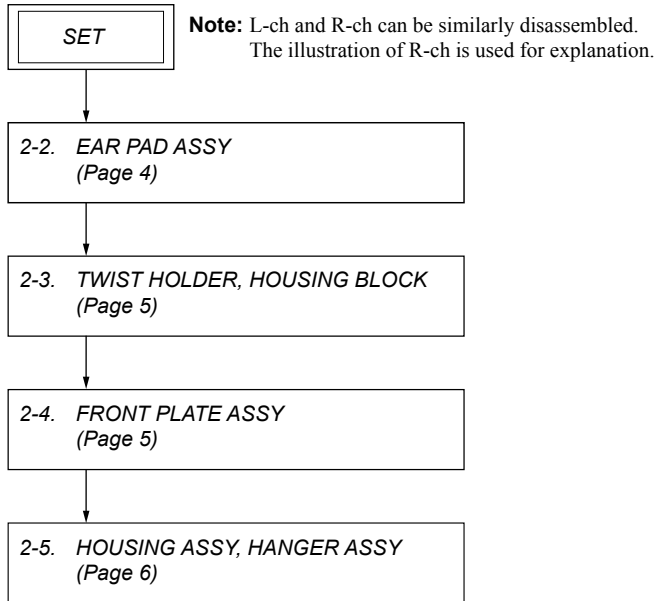

Note: Follow the disassembly procedure in the numerical order given.

2-2. EAR PAD ASSY

Note: L-ch and R-ch can be similarly disassembled. The illustration of R-ch is used for explanation.

• How to Identify the L-ch/R-ch ear pads



• How to install the ear pad assy

① Align the red marks of the ear pad assy and housing block.

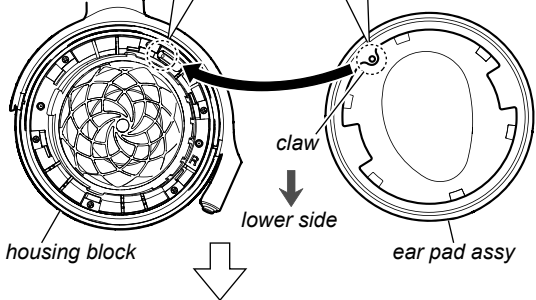
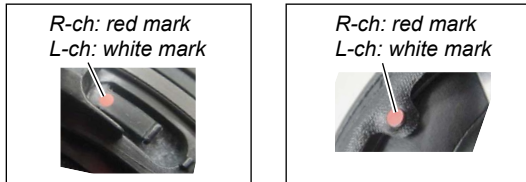

② Align the guide line (unlock) with the mark on the lower side.

(R-ch)

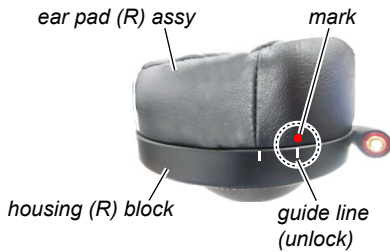

③ Rotate the ear pad assy in the direction of the arrow, and align the mark with the guide line (lock).

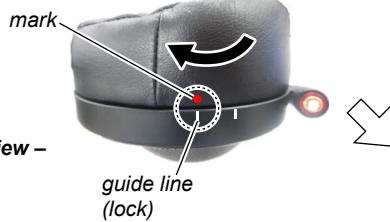

④ Check that the claw is locked as shown in the figure below.

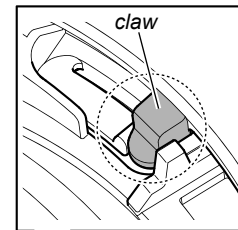

(L-ch)

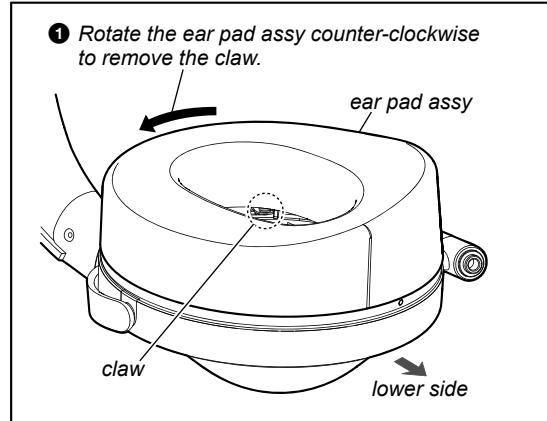
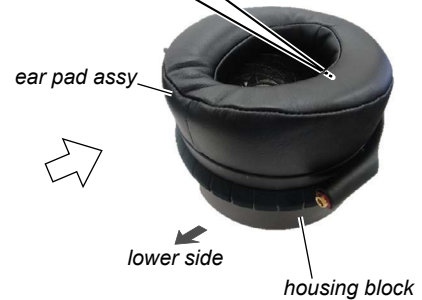
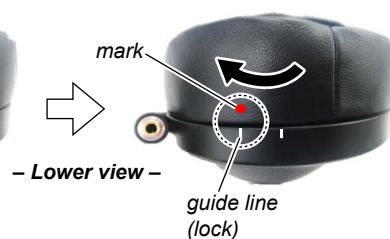
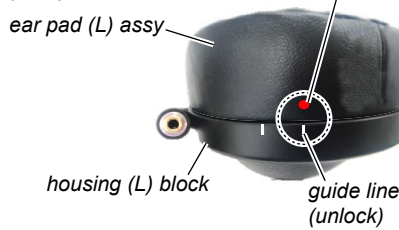

- R-ch -

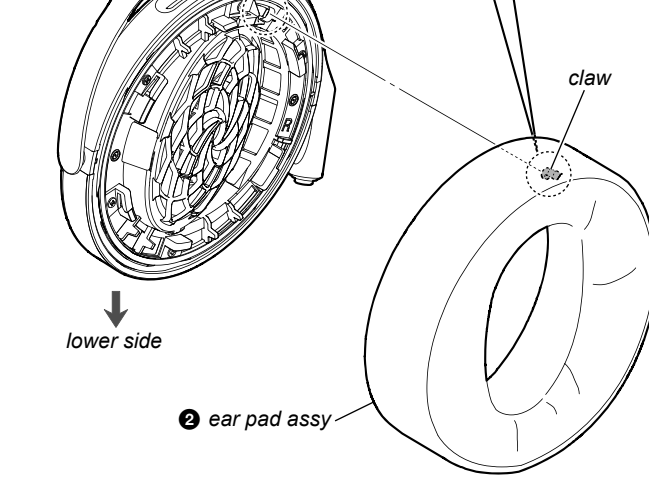

2-3. TWIST HOLDER, HOUSING BLOCK

Note: L-ch and R-ch can be similarly disassembled. The illustration of R-ch is used for explanation.

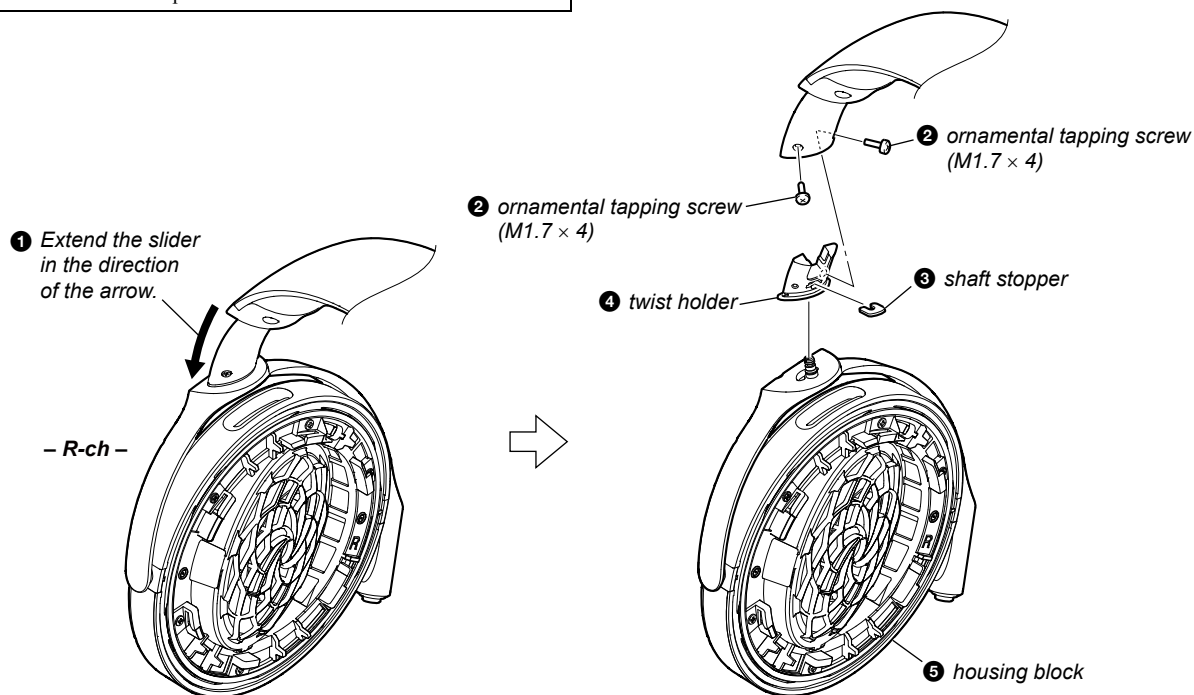

2-4. FRONT PLATE ASSY

Note 1: L-ch and R-ch can be similarly disassembled. The illustration of R-ch is used for explanation.

• **Wire setting** Take care not to damage the U-shaped groove.

Note 2: When installing the front plate block, be careful of the wire getting pinched. (Check that it is secured using the rib and groove as shown in the figure right before installing)



Take care so that the wire is not positioned over the rib.

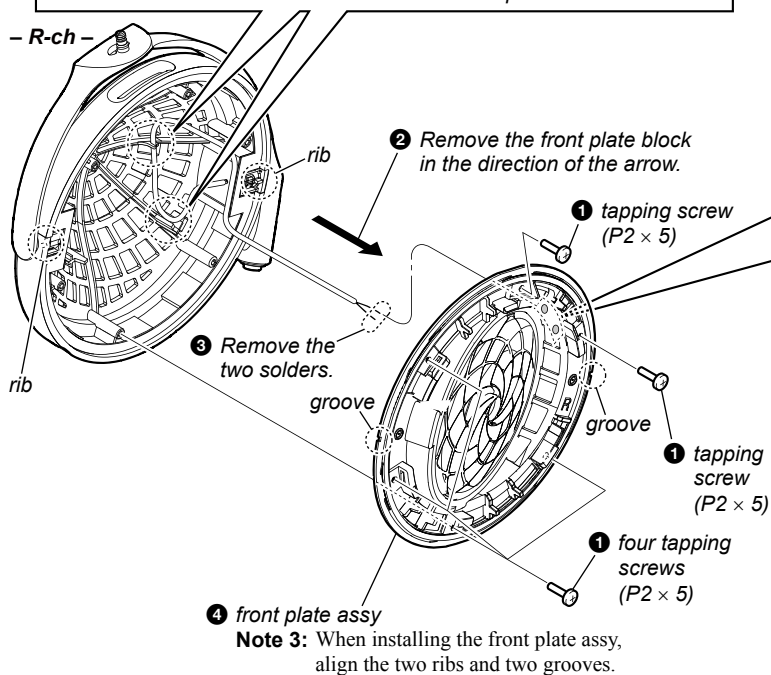

• **Wire setting** (Type A)

[natural]

Note 5: Perform the soldering work in 2 seconds or less.

Note 6: Take care so that the solder does not touch the bond.

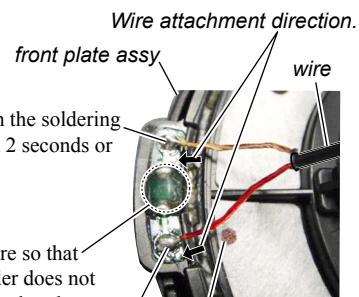

Note 4: The mark side is red wire.

[red]

Note 5: Perform the soldering work in 2 seconds or less.

(Type B)

[red]

Note 5: Perform the soldering work in 2 seconds or less.

Note 6: Take care so that the solder does not touch the bond.

[natural]

Note 5: Perform the soldering work in 2 seconds or less.

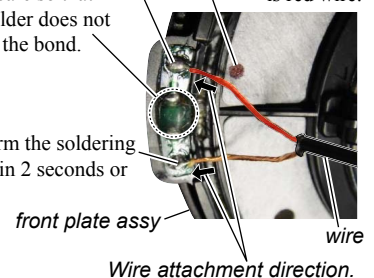

Note 4: The mark side is red wire.

2-5. HOUSING ASSY, HANGER ASSY

Note 1: L-ch and R-ch can be similarly disassembled. The illustration of R-ch is used for explanation.

• How to identify the holder hanger (L) and holder hanger (R)
Note 4: Identify the holder hanger (L) and holder hanger (R) by looking at the engraving on the parts.

“R” : holder hanger (R) “L” : holder hanger (L)

• Jack cable setting

- Pass the jack cable into the housing assy hole.
- Press the jack cable into the holder hanger (R) groove.
- Install the holder hanger (R) while gently pulling the jack cable in the direction of the arrow.

Note 2: When installing the sealing rear cushion, affix the glossy surface to the housing assy.

Note 3: Check that the holder hanger (R) is not raised.

• How to install the holder hanger (L)/(R)

- Pass the jack cable.
- Align the hole and groove.
- Align the hole and groove.

SECTION 3 EXPLODED VIEWS

Note:

- -XX and -X mean standardized parts, so they may have some difference from the original one.
- Items marked "*" are not stocked since they are seldom required for routine service. Some delay should be anticipated when ordering these items.
- The mechanical parts with no reference number in the exploded views are not supplied.
- Color Indication of Appearance Parts Example:
KNOB, BALANCE (WHITE) . . . (RED)

↑ ↑
 Parts Color Cabinet's Color

3-1. R-ch SECTION

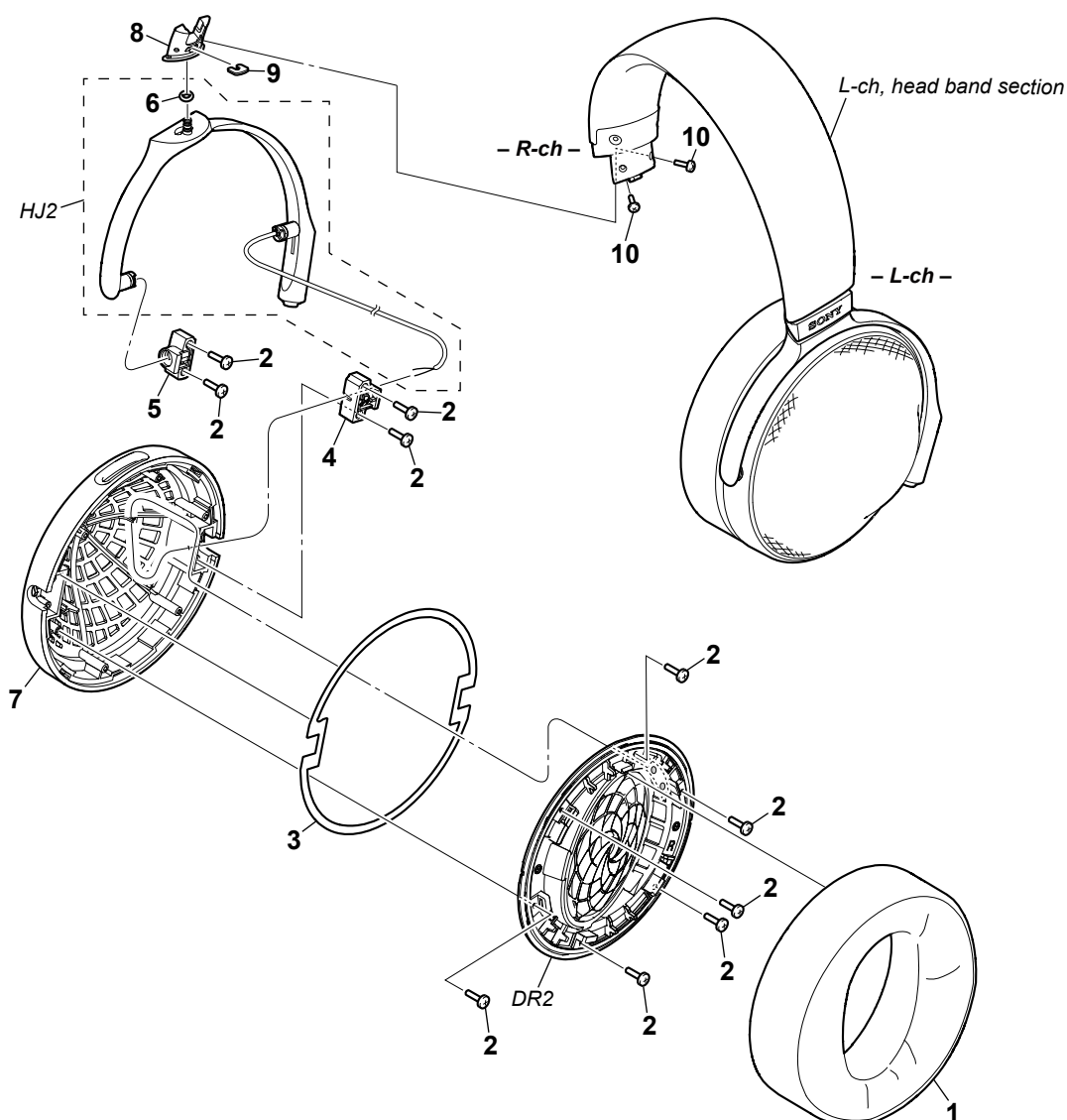

Ref. No.	Part No.	Description	Remark	Ref. No.	Part No.	Description	Remark
1	A-2166-863-A	EAR PAD (R) ASSY (for R-ch)		8	4-592-690-01	HOLDER, TWIST	
2	3-080-206-21	SCREW, TAPPING, P2 (L = 5 mm)		9	4-592-691-01	STOPPER, SHAFT	
3	4-591-213-01	CUSHION, SEALING REAR		10	4-541-006-11	ORNAMENTAL SCREW, M1.7 TAPPING (L = 4 mm)	
4	4-591-221-01	HOLDER, HANGER (R)		DR2	A-2166-710-A	PLATE, FRONT (R) ASSY (Including Driver)	(for R-ch)
5	4-591-220-01	HOLDER, HANGER (L)		HJ2	A-2166-712-A	HANGER (R) ASSY (Including Jack (with cable))	(for R-ch)
6	4-591-217-01	O-RING, ID2 W1					
7	A-2126-358-A	HOUSING (R) ASSY (for R-ch)					

3-2. L-ch, HEAD BAND SECTION

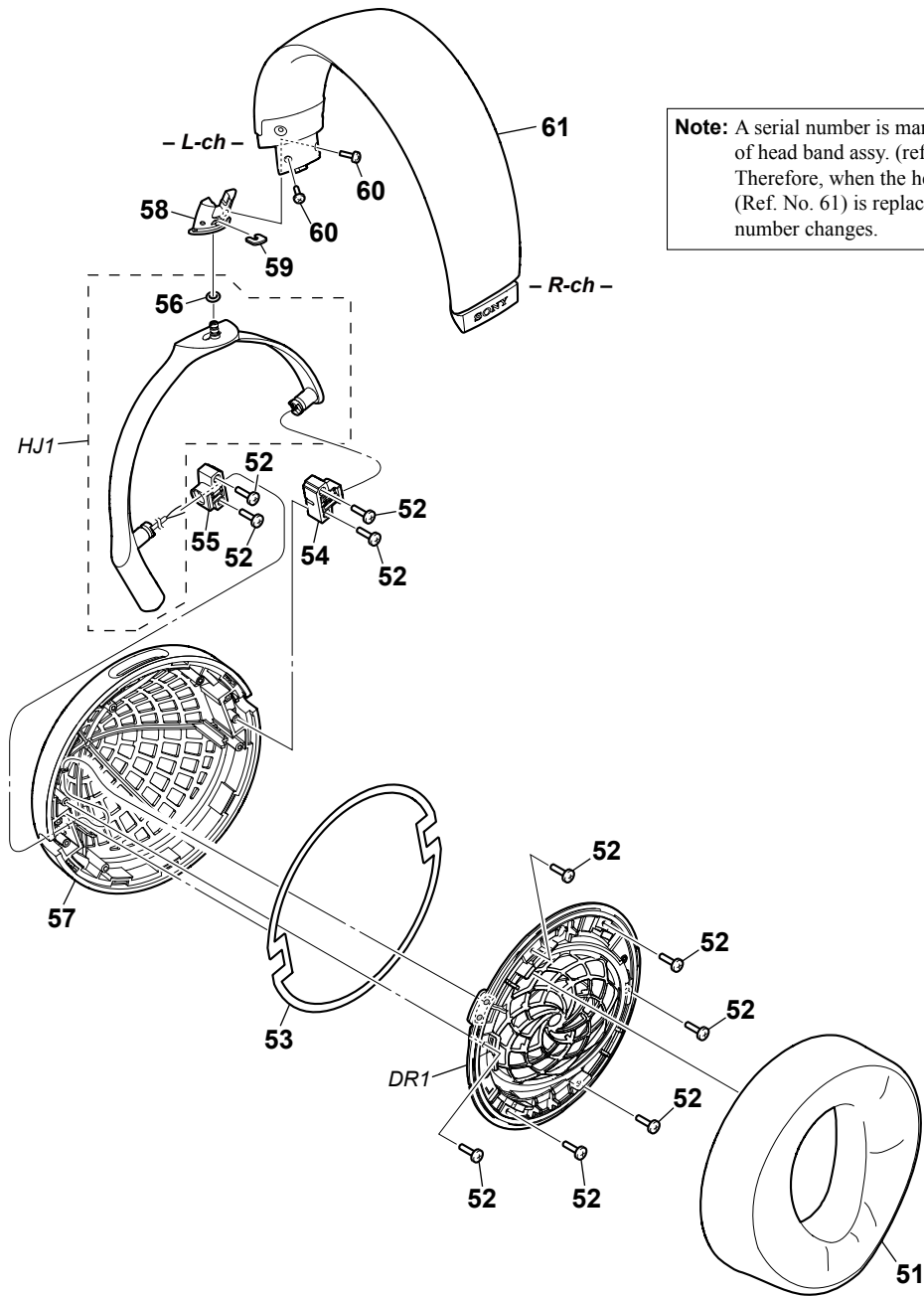

Note: A serial number is marked on the slider of head band assy. (refer to page 2)
Therefore, when the head band assy (Ref. No. 61) is replaced, the serial number changes.

Ref. No.	Part No.	Description	Remark	Ref. No.	Part No.	Description	Remark
51	A-2166-862-A	EAR PAD (L) ASSY (for L-ch)		59	4-592-691-01	STOPPER, SHAFT	
52	3-080-206-21	SCREW, TAPPING, P2 (L = 5 mm)		60	4-541-006-11	ORNAMENTAL SCREW, M1.7 TAPPING (L = 4 mm)	
53	4-591-213-01	CUSHION, SEALING REAR		61	A-2126-356-A	BAND ASSY, HEAD (Chinese) (See Note)	
54	4-591-221-01	HOLDER, HANGER (R)		61	A-2143-302-A	HEAD BAND ASSY (Except Chinese) (See Note)	
55	4-591-220-01	HOLDER, HANGER (L)		DR1	A-2166-709-A	PLATE, FRONT (L) ASSY (Including Driver)	
56	4-591-217-01	O-RING, ID2 W1					(for L-ch)
57	A-2126-357-A	HOUSING (L) ASSY (for L-ch)		HJ1	A-2166-711-A	HANGER (L) ASSY (Including Jack (with cable))	
58	4-592-690-01	HOLDER, TWIST					(for L-ch)

SECTION 4 ACCESSORIES

Ref. No.	Part No.	Description	Remark
	4-593-590-13	MANUAL, INSTRUCTION (ENGLISH, FRENCH, GERMAN, SPANISH, DUTCH, ITALIAN, PORTUGUESE, POLISH, GREEK, CZECH, HUNGARIAN, RUSSIAN, BULGARIAN, SLOVAK, SLOVENIAN, TRADITIONAL CHINESE, KOREAN, ROMANIAN) (Except Chinese)	
	4-593-590-21	MANUAL, INSTRUCTION (SIMPLIFIED CHINESE) (Chinese)	
	4-593-591-11	PRODUCT INFORMATION (ENGLISH, FRENCH, SPANISH) (Except Chinese)	
	4-593-591-21	PRODUCT INFORMATION (GERMAN, DUTCH, ITALIAN) (Except Chinese)	
	4-593-591-31	PRODUCT INFORMATION (RUSSIAN, TRADITIONAL CHINESE, KOREAN) (Except Chinese)	
	4-593-591-42	PRODUCT INFORMATION (SIMPLIFIED CHINESE) (Chinese)	
501	A-2144-924-A	CABLE (W) ASSY (Headphone cable (Approx. 3 m, silver-coated OFC strands, gold-plated stereo mini plug))	
502	A-2144-925-A	CABLE (W, BALANCE) ASSY (Balanced-connection headphone cable (Approx. 1.2 m, silver-coated OFC strands, gold-plated balanced standard plug))	
503	X-2594-062-1	HARD CASE ASSY (Hard case: without serial plate) (See Note)	
504	1-566-410-41	ADAPTOR, PLUG (Gold-plated unimatch plug adaptor (stereo phone plug ↔ stereo mini jack)	

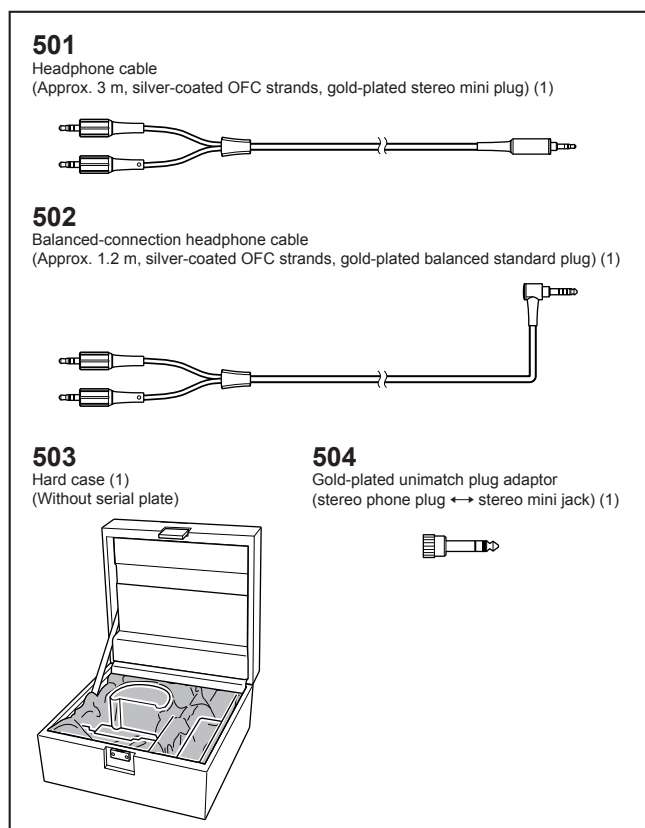

Note: When the hard case assy (Ref. No. 503) is replaced, refer to “NOTE OF REPLACING THE HARD CASE ASSY” on page 2.

