

HISTORY INFORMATION FOR THE FOLLOWING MANUAL:

SERVICE MANUAL

ORIGINAL MANUAL ISSUE DATE: 03/2015

GN1G CHASSIS
Segment: XM-H

Version	Date	Subject
1.0	03/2015	Original manual issue.

LCD TV

SONY®

SERVICE MANUAL

GN1G CHASSIS

Segment: XM-H

LCD TV

SONY®

MODEL LIST

<i>MODEL</i>	<i>COLOR</i>	<i>COMMANDER</i>	<i>DEST.</i>
KDL-65W850C	<i>Black</i>	<i>RMT-TX100U</i>	(UC2) US/CND
KDL-65W855C	<i>Silver</i>	<i>RMT-TX100B</i>	(CR1) COSTA RICA (ECU) ECUADOR (LA8) CHILE PERU VENEZUELA
KDL-65W857C	<i>Silver</i>	<i>RMT-TX100B</i>	(CO1) COLOMBIA
KDL-75W850C	<i>Black</i>	<i>RMT-TX100U</i>	(UC2) US/CND
KDL-75W855C	<i>Silver</i>	<i>RMT-TX100B</i>	(BR6) BRAZIL

<i>MODEL</i>	<i>COLOR</i>	<i>COMMANDER</i>	<i>DEST.</i>
--------------	--------------	------------------	--------------

WARNINGS AND CAUTIONS - ENGLISH

CAUTION

These servicing instructions are for use by qualified service personnel only.

To reduce the risk of electric shock, do not perform any servicing other than that contained in the operating instructions unless you are qualified to do so.

WARNING!!

An isolation transformer should be used during any service to avoid possible shock hazard, because of live chassis.

The chassis of this receiver is directly connected to the ac power line.

CARRYING THE TV

Be sure to follow these guidelines to protect your property and avoid causing serious injury.

- Carry the TV with an adequate number of people; larger size TVs require two or more people.
- Correct hand placement while carrying the TV is very important for safety and to avoid damages.

SAFETY-RELATED COMPONENT WARNING!!

Components identified by shading and Δ mark on the schematic diagrams, exploded views, and in the parts list are critical for safe operation. Replace these components with Sony parts whose part numbers appear as shown in this manual or in supplements published by Sony. Circuit adjustments that are critical for safe operation are identified in this manual.

Follow these procedures whenever critical components are replaced or improper operation is suspected.

CAUTION ABOUT THE LITHIUM BATTERY

- Danger of explosion if battery is incorrectly replaced. Replace only with the same or equivalent type.
- Outer case broken battery should not contact to water.

WARNINGS AND CAUTIONS - FRENCH

ATTENTION!!

Ces instructions de service sont à l'usage du personnel de service qualifié seulement.

Pour prévenir le risque de choc électrique, ne pas faire l'entretien autre que celui contenu dans le Mode d'emploi à moins que vous soyez qualifié faire ainsi.

WARNING!!

Afin d'éviter tout risque d'électrocution provenant d'un châssis sous tension, un transformateur d'isolement doit être utilisé lors de tout dépannage. Le châssis de ce récepteur est directement raccordé à l'alimentation du secteur.

POUR TRANSPORTER LE TÉLÉVISEUR

Tenez compte de ce qui suit pendant l'installation du téléviseur :

- Débranchez tous les câbles avant de transporter le téléviseur.
- Transportez le téléviseur avec le nombre de personnes approprié ; un téléviseur de grande taille doit être transporté par au moins deux personnes.
- Lors du transport du téléviseur, l'emplacement des mains est très important pour votre sécurité, ainsi que pour éviter de causer des dommages.

ALERTE!!

Afin d'éviter tout risque d'électrocution provenant d'un châssis sous tension, un transformateur d'isolement doit être utilisé lors de tout dépannage. Le châssis de ce récepteur est directement raccordé à l'alimentation du secteur.

ATTENTION AUX COMPOSANTS RELATIFS A LA SECURITE!!

Les composants identifiés par une trame et par une marque  sur les schémas de principe, les vues explosées et les listes de pièces sont d'une importance critique pour la sécurité du fonctionnement. Ne les remplacer que par des composants Sony dont le numéro de pièce est indiqué dans le présent manuel ou dans des suppléments publiés par Sony. Les réglages de circuit dont l'importance est critique pour la sécurité du fonctionnement sont identifiés dans le présent manuel. Suivre ces procédures lors de chaque remplacement de composants critiques, ou lorsqu'un mauvais fonctionnement suspecte.

USE CAUTION WHEN HANDLING THE LCD PANEL

When repairing the LCD panel, be sure you are grounded by using a wrist band.

When repairing the LCD panel on the wall, the LCD panel must be secured using the 4 mounting holes on the rear cover.

- 1) Do not press on the panel or frame edge to avoid the risk of electric shock.
- 2) Do not scratch or press on the panel with any sharp objects.
- 3) Do not leave the module in high temperatures or in areas of high humidity for an extended period of time.
- 4) Do not expose the LCD panel to direct sunlight.
- 5) Avoid contact with water. It may cause a short circuit within the module.
- 6) Disconnect the AC power when replacing the backlight (CCFL) or inverter circuit. (High voltage occurs at the inverter circuit at 650Vrms.)
- 7) Always clean the LCD panel with a soft cloth material.
- 8) Use care when handling the wires or connectors of the inverter circuit. Damaging the wires may cause a short.
- 9) Protect the panel from ESD to avoid damaging the electronic circuit (C-MOS).
- 10) It is recommended not to exceed 1 hour of Power-On nor Burn-in period with LCD panel face down condition, in repair activity.

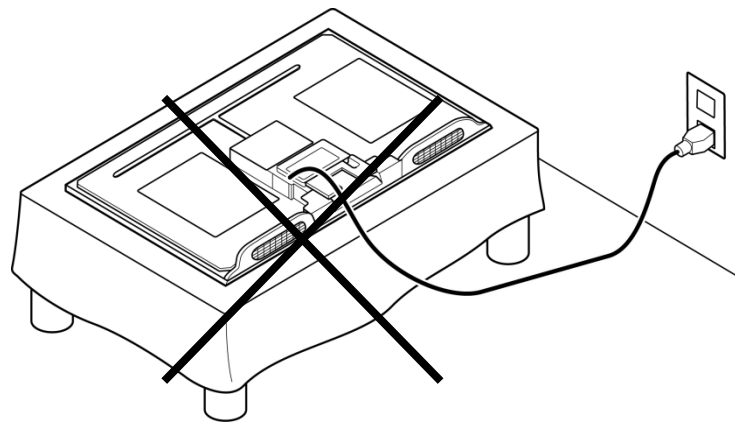

SAFETY CHECK-OUT

After correcting the original service problem, perform the following safety checks before releasing the set to the customer:

1. Check the area of your repair for unsoldered or poorly soldered connections. Check the entire board surface for solder splashes and bridges.
2. Check the interboard wiring to ensure that no wires are “pinched” or touching high-wattage resistors.
3. Check that all control knobs, shields, covers, ground straps, and mounting hardware have been replaced. Be absolutely certain that you have replaced all the insulators.
4. Look for unauthorized replacement parts, particularly transistors, that were installed during a previous repair. Point them out to the customer and recommend their replacement.
5. Look for parts which, though functioning, show obvious signs of deterioration. Point them out to the customer and recommend their replacement.
6. Check the line cords for cracks and abrasion. Recommend the replacement of any such line cord to the customer.
7. Check the antenna terminals, metal trim, “metallized” knobs, screws, and all other exposed metal parts for AC leakage. Check leakage as described below.
8. For safety reasons, repairing the Power board and/or Inverter board is prohibited.

Leakage Test

The AC leakage from any exposed metal part to earth ground and from all exposed metal parts to any exposed metal part having a return to chassis, must not exceed 0.5 mA (500 microamperes).

Leakage current can be measured by any one of three methods.

1. A commercial leakage tester, such as the Simpson 229 or RCA WT-540A. Follow the manufacturers' instructions to use these instructions.
2. A battery-operated AC milliammeter. The Data Precision 245 digital multimeter is suitable for this job.
3. Measuring the voltage drop across a resistor by means of a VOM or battery-operated AC voltmeter. The "limit" indication is 0.75 V, so analog meters must have an accurate low voltage scale. The Simpson's 250 and Sanwa SH-63TRD are examples of passive VOMs that are suitable. Nearly all battery-operated digital multimeters that have a 2 VAC range are suitable (see Figure A).

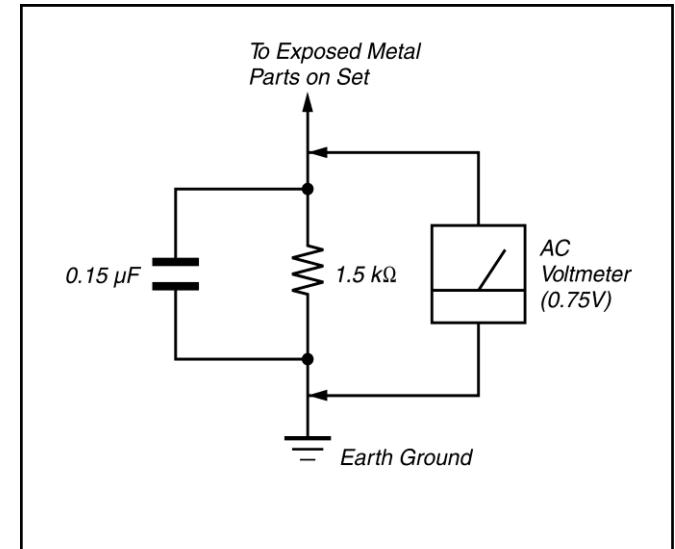

Figure A. Using an AC voltmeter to check AC leakage.

How to Find a Good Earth Ground

A cold-water pipe is a guaranteed earth ground; the cover-plate retaining screw on most AC outlet boxes is also at earth ground.

If the retaining screw is to be used as your earth ground, verify that it is at ground by measuring the resistance between it and a cold-water pipe with an ohmmeter. The reading should be zero ohms.

If a cold-water pipe is not accessible, connect a 60- to 100-watt trouble-light (not a neon lamp) between the hot side of the receptacle and the retaining screw. Try both slots, if necessary, to locate the hot side on the line; the lamp should light at normal brilliance if the screw is at ground potential (see Figure B).

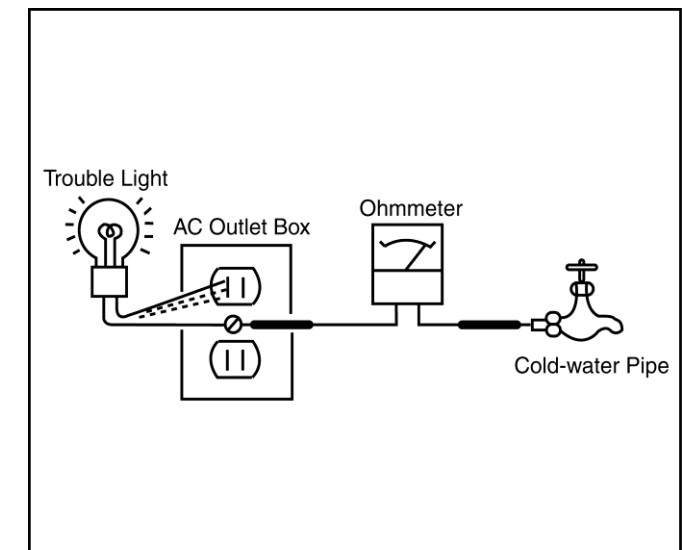

Figure B. Checking for earth ground.

Lead Free Information

The circuit boards used in these models have been processed using Lead Free Solder. The boards are identified by the LF logo located close to the board designation.



Figure 4: LF Logo

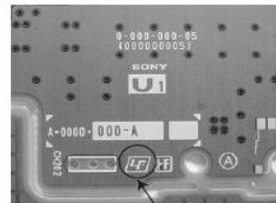

Figure 5: LF logo on circuit board

Handling the FLEXIBLE FLAT CABLE (FFC)

When you insert / pull out FFC, please grasp a reinforcement board and main body of FFC



<GOOD>



<NG>

Please hold reinforcement board and plunge it to depths.

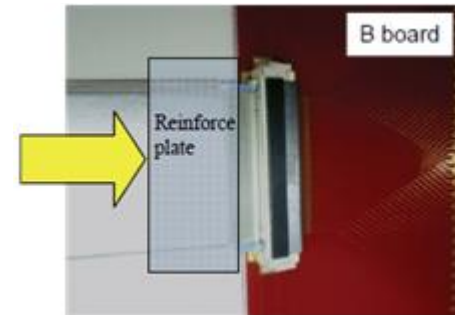

< Insertion >

Please pull out FFC while pushing the button of both ends at the same time.

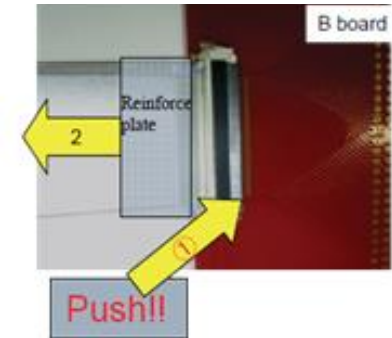

<Pull out>

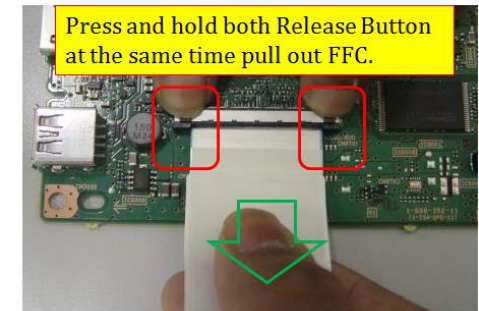
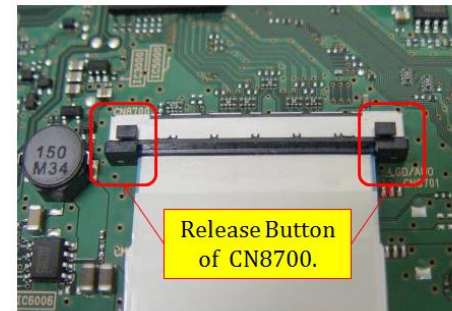

FFC connector broken if pull out FFC without press and hold both Release Button of CN8700.Symptom 5X blinkings will be appear due to improperly seated.

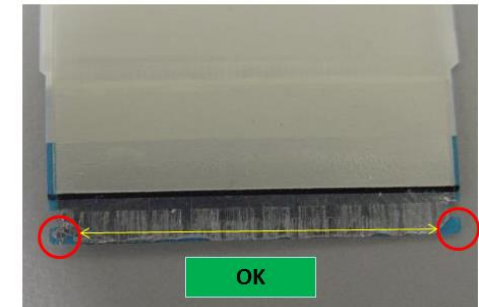

SELF DIAGNOSIS FUNCTION

OUTLINE OF SELF DIAGNOSIS FUNCTION

The units in this manual contain a self-diagnostic function. If an error occurs, the STANDBY LED will automatically begin to flash.

The number of times the LED flashes translates to a probable source of the problem.

A definition of the STANDBY LED flash indicators is listed in the instruction manual for the user's knowledge and reference.

If an error symptom cannot be reproduced, the remote commander can be used to review the failure occurrence data stored in memory to reveal past problems and how often these problems occur.

ABOUT ILLUMINATION LED

Status	White Center LED	Side RGB LED	Side Amber LED	Remarks
Power Off (by power saving switch off and *1)	Off	Off	Off	*1 power switch off (by side key)
Power On	White	Off	Off	
STBY/i.LINK STBY/PC STBY (by remote control off only)	Off	Off	Off	
Picture Off	White looping	White one shot	Off	
Device Connection	White	Cyan one shot	Off	
Power ON Animation	White	White one shot	Off	
Sleep Timer/On Timer/Reminder/REC Timer/Photo Frame (Power On)	White	Amber One shot -> Lit*2	Off	*2 One Shot is only user action.
On Timer/Reminder/REC Timer (Deep Standby)	Off	Off	Amber	After 5 minutes, side amber LED On
Self Diagnosis	Off	Red Blinking	Off	The number of LED blinking indicates cause of failure (refer to Led Error / Triage chart)
Aging mode	White	Green Blinking	Off	Blinking:0.5sec On / 0.5sec Off
Software Updating	white blinking	white blinking	Off	
Software Updating finish	White	Blue lit	Off	
Test Reset	White	white blinking	Amber blinking	
Error of panel ID	White	Green /Amber Blinking	Off	Blinking:0.5sec On / 0.5sec Off
REC (SCART REC & HDD REC/LIVE PAUSE) [AEP/J only]	White	Red(Pink) One shot -> Lit*2	Off	*2 One Shot is only user action.
ePOP/ Shop Illumination	White	Cyan loop	Off	One shot Center White when feature change

DIAGNOSTIC TEST INDICATORS

When an error occurs, the STANDBY LED will flash a set number of times to indicate the possible cause of the problem.

If there is more than one error, the LED will identify the first of the problem areas.

Result for all of the following diagnostic items are displayed on screen.

If the screen displays a "0", no error has occurred .

DISPLAY OF STANDBY LED FLASH COUNT

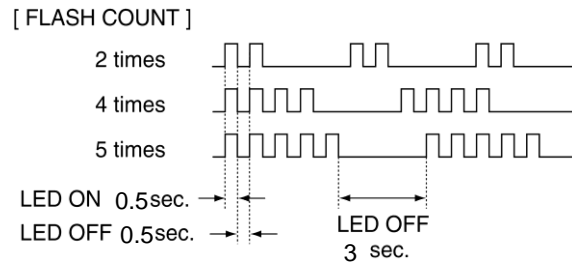

Note: One flash counts is not self-diagnostic.

Smart Core RED LED blinking count	Detection Items	Board Error Item
2x	Main 12V failure [MAIN_POWE] * This failure is not saved	<ul style="list-style-type: none"> ▪ G** Board Error ▪ BMX Board Error
3x	Main 5.0V failure [DC_ALERT]	<ul style="list-style-type: none"> ▪ BMX Board Error
	Audio amp. protection [AUD_ERR]	<ul style="list-style-type: none"> ▪ BMX Board Error ▪ Speaker
5x	Tuner or demodulator I2C NACK [TU_DEMOD]	<ul style="list-style-type: none"> ▪ BMX Board Error
	<i>Panel ID EEPROM I2C NACK (Also panel power failure is a suspect) [P_ID_ERR]</i> (*detect at startup sequence only)	<ul style="list-style-type: none"> ▪ Panel module ▪ Tcon board ▪ G** Board Error ▪ BMX Board Error
	FRC device I2C No ACK [FRCTC_I2C]	<ul style="list-style-type: none"> ▪ Tcon board
6x	<i>FRC device Initialization failure [FRCTC_I2C]</i> (*detect at startup sequence only)	<ul style="list-style-type: none"> ▪ Tcon board
	Backlight failure [BACKLIGHT]	<ul style="list-style-type: none"> ▪ Panel module ▪ G** Board Error ▪ BMX Board Error
7x	Over temperature protection [TEMP_ERR] Temp. sensor I2C NACK [TEMP_ERR]	<ul style="list-style-type: none"> ▪ BMX Board Error

Size	G* Board Type
65"	GL1SB
75"	GL1C

SELF-DIAGNOSTIC SCREEN DISPLAY

For errors with symptoms such as “power sometimes shuts off” or “screen sometimes goes out” that cannot be confirmed, it is possible to bring up past occurrences of failure for confirmation on the screen:

[To Bring Up Screen Test]

In standby mode, press buttons on the remote commander sequentially in rapid succession as shown below:

i+ (info) → Channel **5** → Volume ^{*} **-** → **TV POWER**

* : Note that this differs from entering the service mode (volume +)

Since the diagnostic results displayed on the screen are not automatically cleared, always check the self-diagnostic screen. After you have completed the repairs, clear the result display to “0”.

Clearing the Self Check Diagnostic List

- | | |
|------------------------------------|------------------------------------|
| 1. Error history and Error count : | Press the Channel 8 => Channel 0 . |
| 2. Panel operation time : | Press the Channel 7 => Channel 0 . |

Exiting the Self-diagnostic screen

To exit the Self Diagnostic screen, turn off the power to the TV by pressing the POWER button on the remote or the POWER button on the TV.

[SELF DIAGNOSTIC SAMPLE SCREEN DISPLAY]

Format of error timestamps

YYMMDDhhmmss (in UTC)

Example:

150823132523 -> Aug 23 2015 13:25:23 UTC

* Only when time is set, an error timestamp is saved.

Error Naming

Error count

Smart Core Red LED blinking count

•Panel Operation Time is recorded every 30 min, but Total Operation Time is recorded every 1 hr. Therefore, the panel op. time might become larger than the total op. time.

SELF CHECK

Back				
002	MAIN_POWER	000000000000	000000000000	000000000000 000
003	DC_ALERT	000000000000	000000000000	000000000000 000
003	AUD_ERR	000000000000	000000000000	000000000000 000
003	HDMI_EQ	000000000000	000000000000	000000000000 000
003	TU_DEMOD	000000000000	000000000000	000000000000 000
004	LD_ERR	000000000000	000000000000	000000000000 000
004	BCM_ERR	000000000000	000000000000	000000000000 000
005	TCON_ERR	000000000000	000000000000	000000000000 000
005	P_ID_ERR	000000000000	000000000000	000000000000 000
005	FRCTC_I2C	000000000000	000000000000	000000000000 000
006	BACKLIGHT_ERR	000000000000	000000000000	000000000000 000
007	TEMP_ERR	000000000000	000000000000	000000000000 000
007	4KBE_ERR	000000000000	000000000000	000000000000 000
008	SW_ERR	000000000000	000000000000	000000000000 000
00000	00000	00000		

[Home]Exit

Error timestamp for last recorded

Error timestamp for second last recorded

Error timestamp for 3rd last recorded

Total Operation Time [hr] – Boot Count – Panel Operation Time [hr]

SEC 1. DISASSEMBLY AND PARTS LIST

- Items with no part number and no description are not stocked because they are seldom required for routine service.
- The construction parts of an assembled part are indicated with a collation number in the remark column.
- Items marked " * " are not stocked since they are seldom required for routine service. Some delay should be anticipated when ordering these items.

The components identified by shading and mark \triangle are critical for safety. Replace only with part number specified.

The components identified by mark \square contain confidential information. Strictly follow the instructions whenever the components are repaired and/or replaced.

Note: About the procedure to disassemble under cover(standing position), please refer to “APPENDIX-1”.

1-1. KDL-65W850C/855C/857C

1-1-1. Disassembly, Exploded View

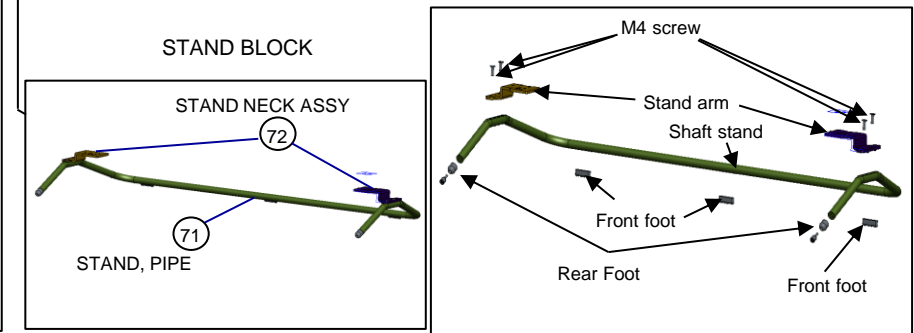
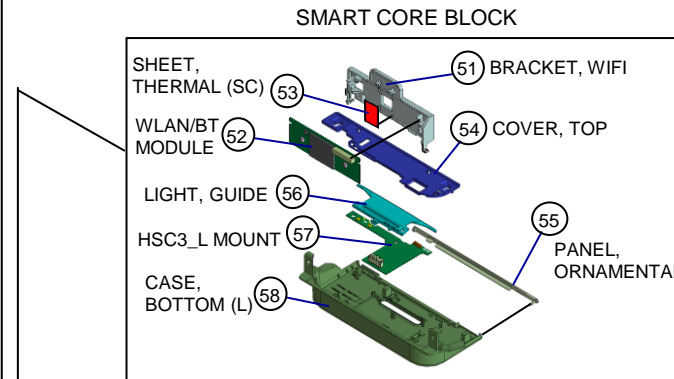
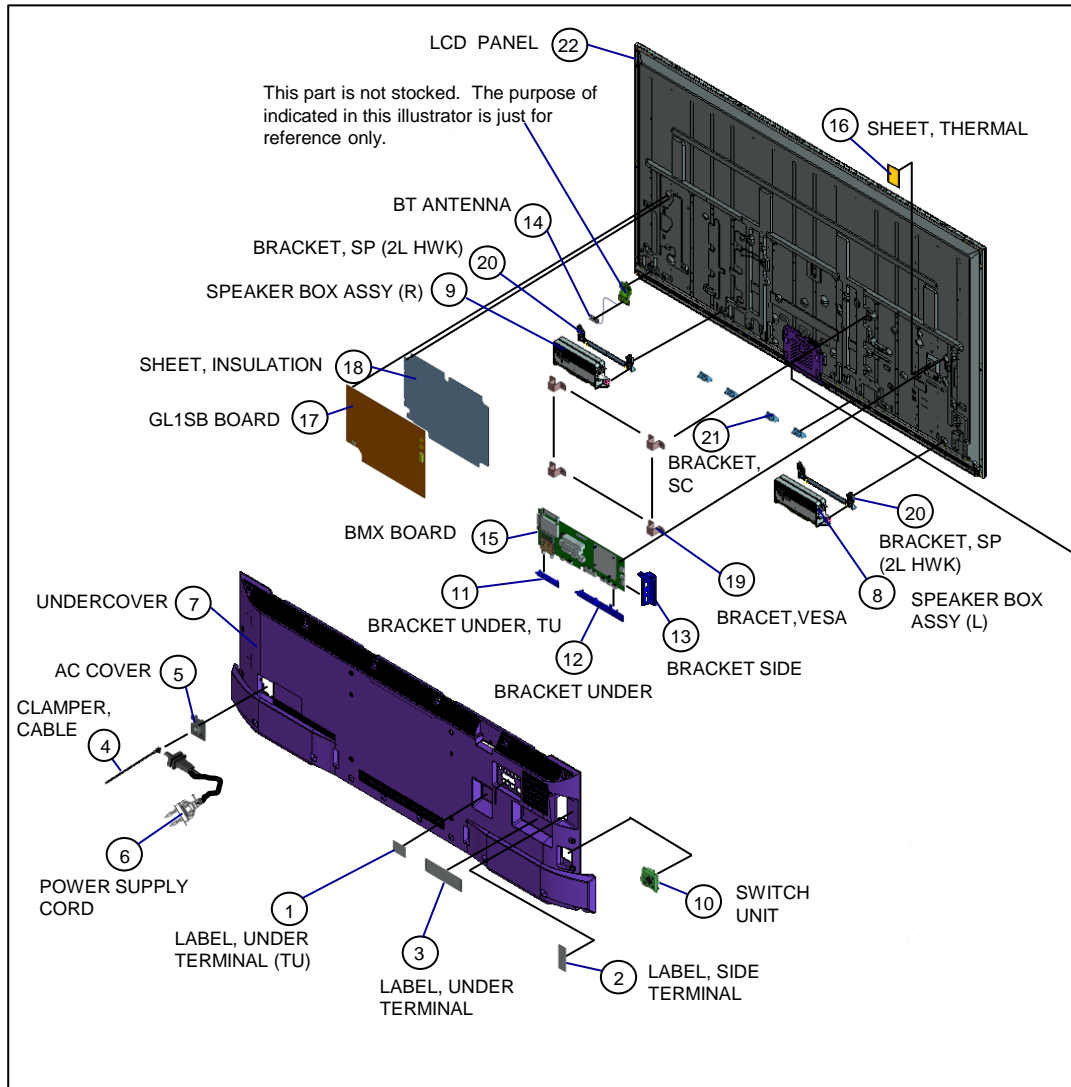

1-1. KDL-65W850C/855C/857C**1-1-1. Disassembly, Exploded View**

REF. No.	PART No.	DESCRIPTION	MARK	REF. No.	PART No.	DESCRIPTION	MARK
1	4-563-190-11	LABEL, UNDER TERMINAL(TU)	CO1/LA8/CR1/ECU	51	4-564-318-01	BRACKET, WIFI	
1	4-563-190-21	LABEL, UNDER TERMINAL(TU)	UC2	52	1-458-854-11	WLAN/BT MODULE (11N)	
2	4-563-252-01	LABEL, SIDE TERMINAL		53	4-549-528-01	SHEET, THERMAL (SC)	
3	4-563-273-01	LABEL, UNDER TERMINAL	UC2	54	4-564-317-01	COVER, TOP	
3	4-563-273-11	LABEL, UNDER TERMINAL	CO1/LA8/CR1/ECU	55	4-564-312-01	PANEL, ORNAMENT	
4	4-262-708-04	CLAMPER, CABLE		56	4-564-313-01	LIGHT, GUIDE	
5	4-299-531-01	AC COVER		57	A-2066-086-A	HSC3_L MOUNT	
6	▲ 1-839-691-12	POWER-SUPPLY CORD (WITH CONN.)	LA8/CR1/ECU	58	4-564-316-01	CASE, BOTTOM (L)	
6	▲ 1-839-696-12	POWER-SUPPLY CORD (WITH CONN.)	UC2/CO1				
7	4-546-827-11	UNDER COVER (2L_EGL) A	UC2	71	4-546-889-01	STAND,PIPE (2L EGL) A	
7	4-546-827-21	UNDER COVER (2L_EGL) A	LA8/CR1/ECU	72	4-546-910-01	STAND NECK ASSY	
7	4-546-827-31	UNDER COVER (2L_EGL) A	CO1				
8	1-859-007-11	SPEAKER BOX ASSY (L)					
9	1-859-007-21	SPEAKER BOX ASSY (R)					
10	1-798-510-31	SWITCH UNIT (SM-G-WW)					
11	4-546-909-12	BRACKET, UNDER TU (MOLD)	CO1/LA8/CR1/ECU				
11	4-546-909-32	BRACKET, UNDER TU (MOLD)	UC2				
12	4-545-088-11	BRACKET, UNDER (MOLD)					
13	4-545-087-01	BRACKET, SIDE (MOLD)					
14	1-754-949-11	BT ANTENNA					
15	🔒 A-2068-394-A	COMPL SVC BMX_XMH_BR GINGA	CR1/ECU				
15	🔒 A-2068-395-A	COMPL SVC BMX_XMH_UC	UC2				
15	🔒 A-2068-401-A	COMPL SVC BMX_XMH_COL	CO1				
15	🔒 A-2073-259-A	COMPL SVC BMX_XMH_BR	LA8				
16	4-549-186-01	SHEET, THERMAL (BM)					
17	▲ 1-474-610-11	GL1SB-STATIC CONVERTER (TV)					
18	4-549-182-01	SHEET, INSULATION (HWK 2L)					
*	19	4-546-473-01	BRACET, VESA (HWK)				
	20	4-546-824-01	BRACKET, SP (2L HWK) A				
	21	4-546-470-01	BRACKET, SC (EGL)				
	22	▲ 1-812-090-11	LCD PANEL (A65HVF6S)				CO1/LA8/CR1/ECU
	22	▲ 1-812-091-11	LCD PANEL (A65HVF6B)				UC2

1-1. KDL-65W850C/855C/857C

1-1-2. Screws

Ref	Part No	Description
■	4-452-935-11	SCREW , +PWH M3X6
□	2-580-639-01	SCREW, +BVTP 4X12 TYPE2 IT-3
●	4-256-393-11	SCREW, +PSW M3X6 W12
○	2-990-421-41	SCREW (+PSW) (M3X6)
▲	4-159-298-01	SCREW, +PSW M4X10
△	4-567-082-01	SCREW, +PSW M5X20
★	4-268-126-02	SCREW, ORNAMENTAL M6X12
◆	2-580-593-01	SCREW, +PSW M3X8
◆	2-580-600-11	SCREW, +PSW M4X8

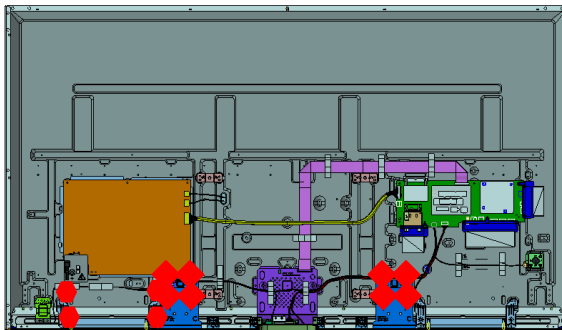
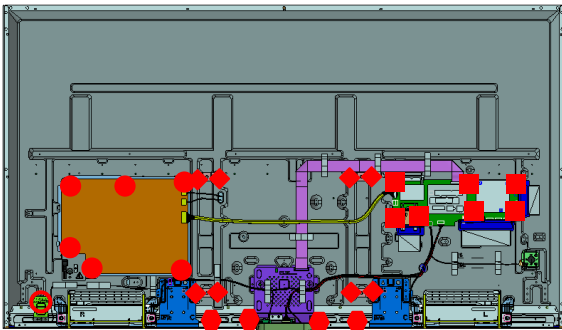
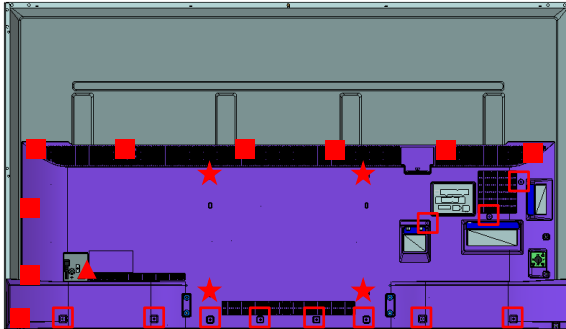

1-1. KDL-65W850C/855C/857C

1-1-3. Connectors

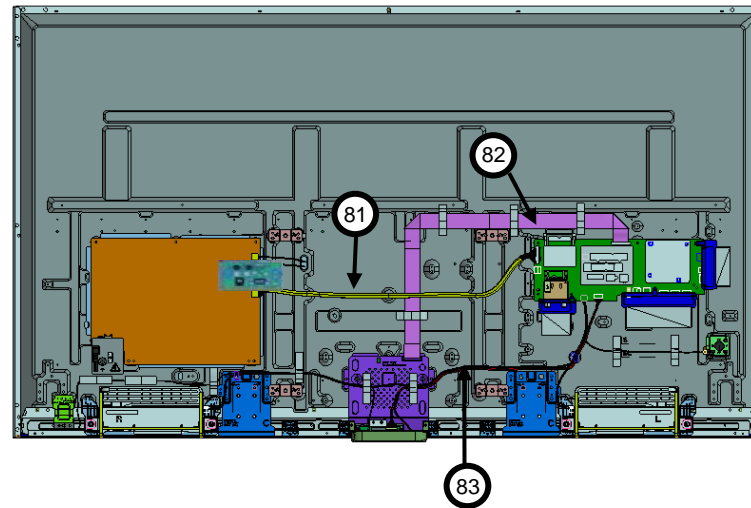

REF. No.	PART No.	DESCRIPTION	MARK
81	1-910-804-95	CONNECTOR ASSY 30P	CN9000(BMX)-CN6401(GL1B)(1)
82	1-848-825-11	FLEXIBLE FLAT CABLE 51P	CN8400(BMX)-T-CON(1)
83	1-910-804-94	HARNESS ASSY	CN1000(BMX)-CN203(SM)-CN101(HSC3-L)- (WIFI/BT) / CN7751(BMX)-SP(1)

1-2. KDL-75W850C/855C

1-2-1. Disassembly, Exploded View

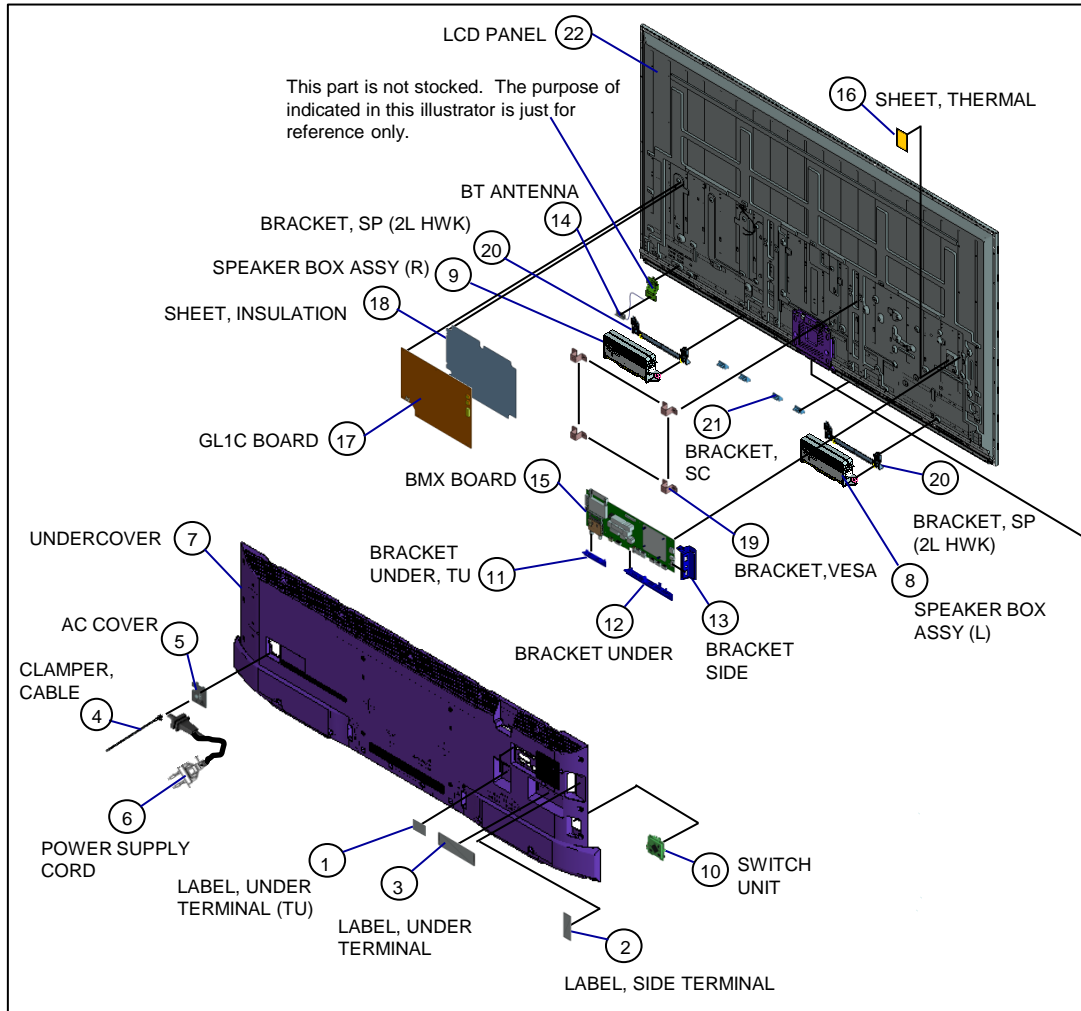

SMART CORE BLOCK

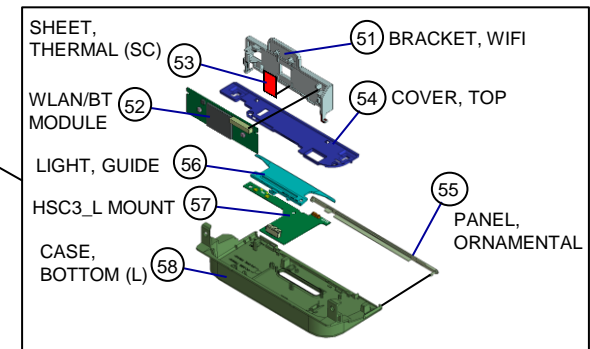

STAND BLOCK

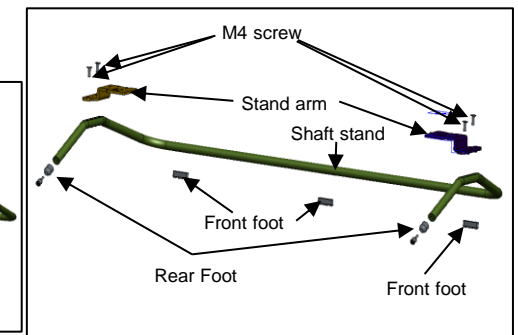
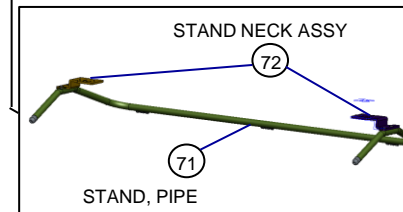

1-2. KDL-75W850C/855C

1-2-1. Disassembly, Exploded View

REF. No.	PART No.	DESCRIPTION	MARK	REF. No.	PART No.	DESCRIPTION	MARK
1	4-563-190-21	LABEL, UNDER TERMINAL (TU)	UC2	51	4-547-397-01	BRACKET, WIFI	BR6
1	4-563-190-11	LABEL, UNDER TERMINAL (TU)	BR6	51	4-564-318-01	BRACKET, WIFI	UC2
2	4-563-252-01	LABEL, SIDE TERMINAL		52	1-458-854-11	WLAN/BT MODULE(11N)	
3	4-563-273-01	LABEL, UNDER TERMINAL	UC2	53	4-549-528-01	SHEET, THERMAL (SC)	
3	4-563-273-11	LABEL, UNDER TERMINAL	BR6	54	4-547-395-01	COVER, TOP	BR6
4	4-262-708-04	CLAMPER, CABLE		54	4-564-317-01	COVER, TOP	UC2
5	4-299-531-01	AC COVER	UC2	55	4-564-312-01	PANEL, ORNAMENT	UC2
5	4-297-989-01	AC COVER	BR6	55	4-547-389-01	PANEL, ORNAMENT	BR6
6	▲ 1-846-001-11	POWER SUPPLY CORD (WITH CONN)		56	4-564-313-01	LIGHT, GUIDE	UC2
7	4-546-828-11	UNDER COVER (3L_EGL) A	UC2	56	4-547-390-01	LIGHT, GUIDE	BR6
7	A-2068-963-A	UNDER COVER (3L_EGL) A	BR6	57	A-2066-086-A	HSC3_L MOUNT	
8	1-859-007-11	SPEAKER BOX ASSY (L)		58	4-547-393-01	CASE, BOTTOM (L)	BR6
9	1-859-007-21	SPEAKER BOX ASSY (R)		58	4-564-316-01	CASE, BOTTOM (L)	UC2
10	1-798-510-41	SWITCH UNIT (SM-G-KIT)	BR6				
10	1-798-510-31	SWITCH UNIT (SM-G-VW)	UC2	71	4-546-894-01	STAND,PIPE (3L EGL) A	UC2
11	4-546-909-32	BRACKET, UNDER TU (MOLD)	UC2	71	A-2068-965-A	STAND,PIPE (3L EGL) A	BR6
11	4-546-909-42	BRACKET, UNDER TU (MOLD)	BR6	72	4-546-910-01	STAND NECK ASSY	UC2
12	4-545-088-11	BRACKET, UNDER (MOLD)	UC2	72	A-2069-466-A	STAND NECK ASSY	BR6
12	4-545-088-41	BRACKET, UNDER (MOLD)	BR6				
13	4-545-087-01	BRACKET, SIDE (MOLD)	UC2				
13	4-545-087-11	BRACKET, SIDE (MOLD)	BR6				
14	1-754-949-11	BT ANTENNA					
15	🔒 A-2068-394-A	COMPL SVC BMX_XMH_BR GINGA	BR6				
15	🔒 A-2068-395-A	COMPL SVC BMX_XMH_UC	UC2				
16	4-570-777-01	SHEET, THERMAL (BM17)					
17	▲ 1-474-609-11	GL1C-STATIC CONVERTER(TV)					
18	4-549-400-01	SHEET, INSULATION (EGL 3L)					
*	19	4-546-473-01	BRACET,VESA (HWK)				
	20	4-546-824-01	BRACKET, SP (2L HWK) A				UC2
	21	4-546-470-01	BRACKET, SC (EGL)				
	22	▲ 1-812-093-11	LCD PANEL (B75HF59B)				UC2
	22	▲ 1-812-092-11	LCD PANEL (B75HF59S)				BR6

1-2. KDL-75W850C/855C

1-2-2. Screws

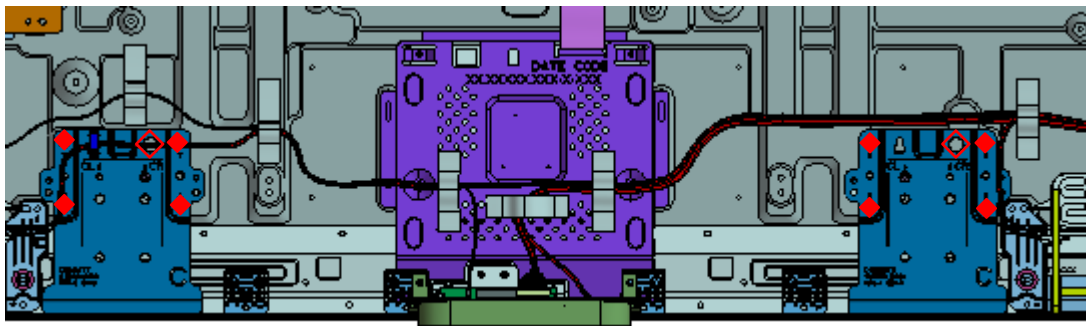
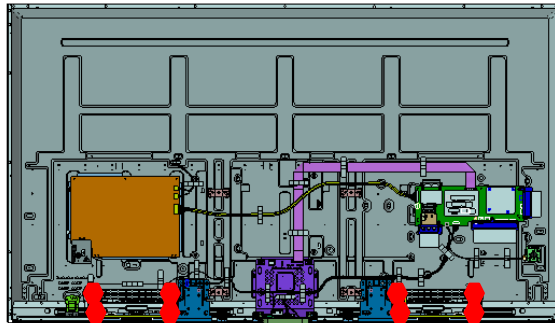
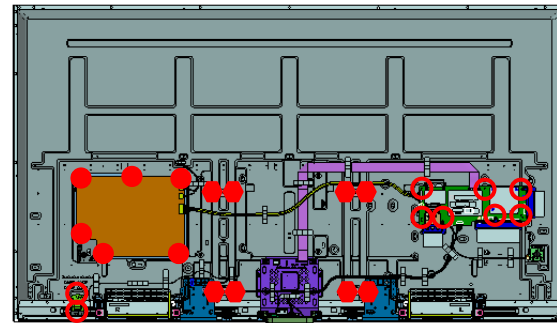
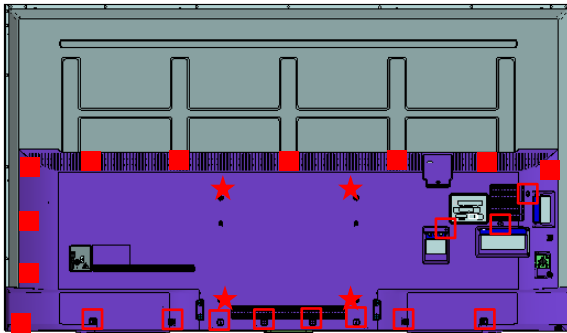

Ref	Part No	Description
■	4-452-935-11	SCREW , +PWH M3X6
□	2-580-639-01	SCREW , +BVTP 4X12 TYPE2 IT-3
●	4-256-393-11	SCREW , +PSW M3X6 W12
○	2-990-421-41	SCREW (+PSW) (M3X6)
▲	4-159-298-01	SCREW , +PSW M4X10
△	4-567-082-01	SCREW , +PSW M5X20
★	4-268-126-02	SCREW , ORNAMENTAL M6X12
●	2-580-593-01	SCREW , +PSW M3X8
◆	2-580-600-11	SCREW , +PSW M4X8
◇	4-534-964-01	PULLEY, STAND (HWI)

1-2. KDL-75W850C/855C

1-2-3. Connectors

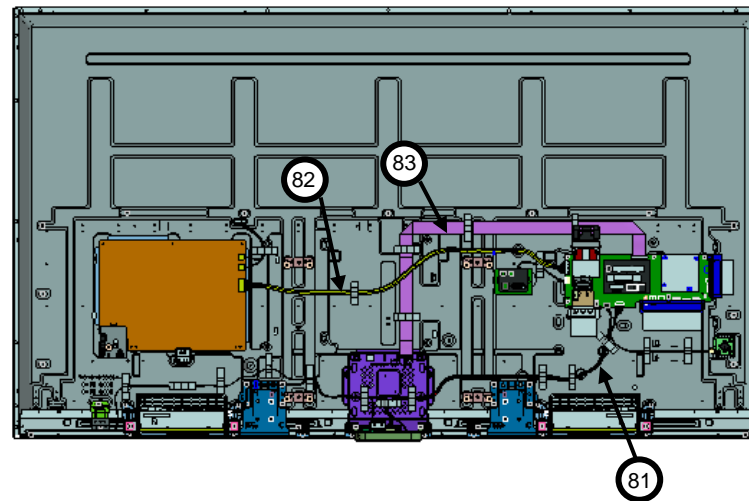

REF. No.	PART No.	DESCRIPTION	MARK
81	1-910-804-96	HARNESS ASSY	CN1000(BMX)-CN203(SM)-CN101(HSC3-L)- (WIFI/BT) / CN7751(BMX)-SP(1)
82	1-910-804-97	CONNECTOR ASSY 30P	CN9000(BMX)-CN6401(GL1B)(1)
83	1-848-826-11	FLEXIBLE FLAT CABLE 51P(UC2)	CN8400(BMX)-T-CON(1)
83	1-848-823-11	FLEXIBLE FLAT CABLE 51P(BR6)	CN8400(BMX)-T-CON(1)

1-3. KDL-65W850C/855C/857C,75W850C/855C**1-3-1. MISCELLANEOUS**

PART No.	DESCRIPTION	MARK
2-650-770-21	SLIDE, CLAMP	
* 4-534-964-01	PULLEY, STAND (HWI)	
7-600-031-97	TAPE (3M 1350FB-1)15MMX66M BLK	

1-3-2. ACCESSORIES

PART No.	DESCRIPTION	MARK
1-492-975-21	REMOTE COMMANDER (RMT-TX100B)	CO1/LA8/CR1/ECU
1-492-975-31	REMOTE COMMANDER (RMT-TX100B)	BR6
1-492-978-21	REMOTE COMMANDER (RMT-TX100U)	UC2
▲ 1-785-504-21	ADAPTOR, CONVERSION	LA8/CR1/ECU
▲ 1-839-691-12	POWER-SUPPLY CORD (WITH CONN.)	LA8/CR1/ECU
▲ 1-839-696-12	POWER-SUPPLY CORD (WITH CONN.)	UC2/CO1
1-845-283-14	IR BLASTER	UC2
* 1-848-803-11	RCA CONVERSION CABLE	BR6/CO1/LA8/ CR1/ECU
* 4-562-056-11	REFERENCE GUIDE	UC2
* 4-562-057-31	REFERENCE GUIDE	CR1/ECU
* 4-562-058-31	REFERENCE GUIDE	CO1/LA8
* 4-562-059-11	REFERENCE GUIDE	BR6
* 4-567-082-01	SCREW, +PSW M5X20 (For STAND)	
* 4-567-081-01	SCREW, +PSW M6X12 (For STAND)	
7-600-031-96	TAPE (3M 1350FW-1)15MMX66M WHT	

SEC 2. ADJUSTMENT

ACCESSING SERVICE MODE

- 1) Turn on the main power switch to place this set in standby mode.
- 2) Press the buttons on the remote commander as follows, and entering service mode.

i+ (info) → Channel **5 → Volume **+** → **TV POWER****

- 3) Service mode display.

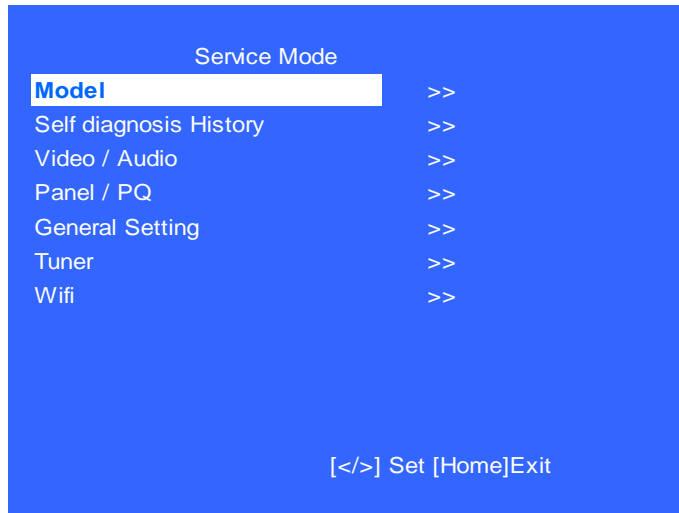

- 4) How to use the remote commander.

Function	The flow of control
Service mode on	<Test>+<TV>/ <Display><5><Vol Up><Power>
Service mode off	<MENU>/<HOME>
Item up / down	<↑>/ <↓>
Execute	<OK>

- 5) After entering service mode, then turn off the power switch.

ACCESSING SOFTWARE VERSION

- 1) In Service Mode, select “Model Information “ Press ⊕ (Enter)
or ➡ button on Remote to enter status information.

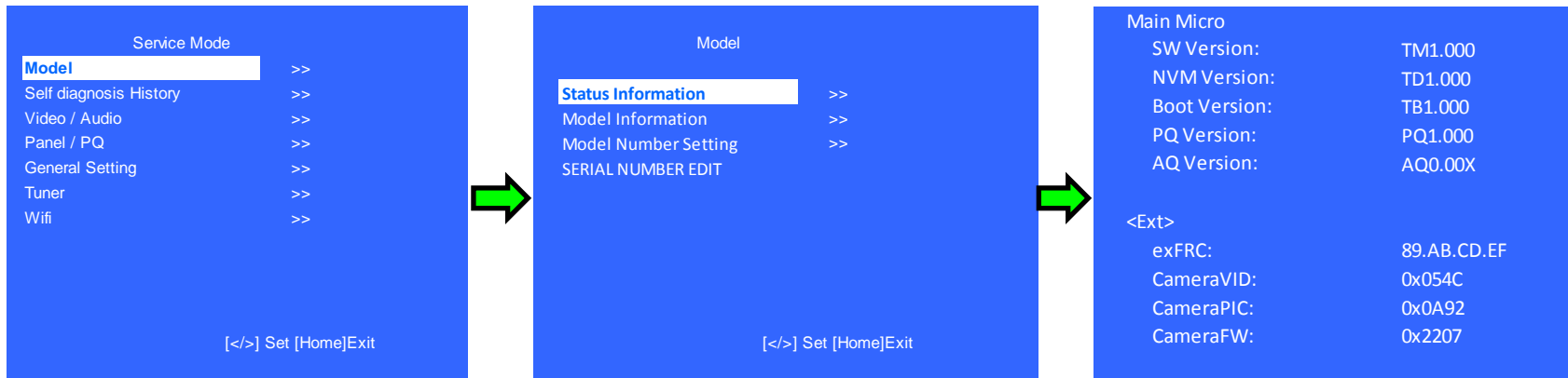

- 2) Press ⊕ (Enter) or “Return” button on Remote to back to Service Mode.

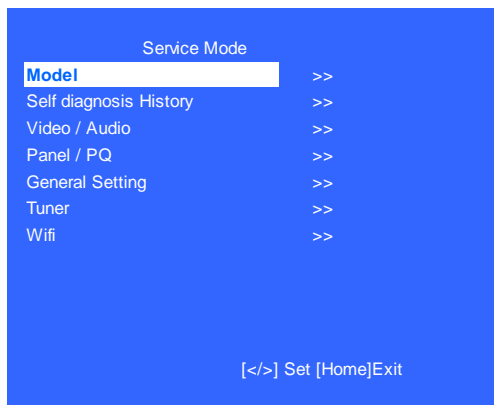

ACCESSING SERIAL NUMBER EDIT

1) In Service Mode, select "Model" pressing **➡** button. Select "Serial Number Edit" pressing **➡** button.

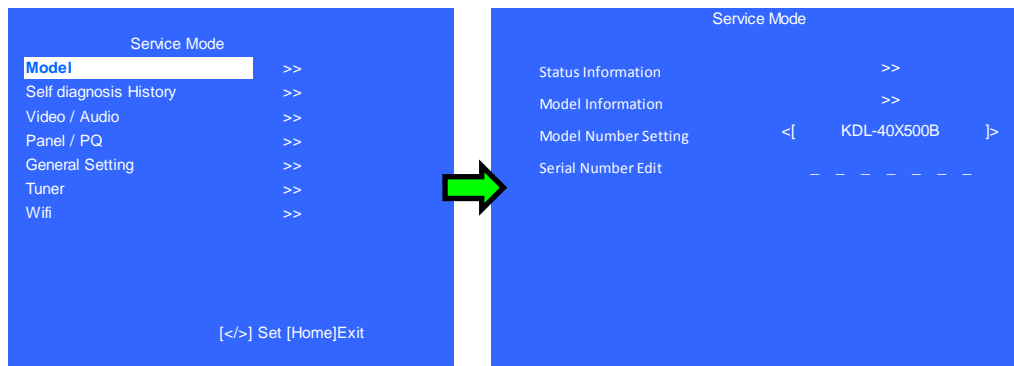

2) Press **↑** or **↓** button to select number.

* The font color of "Yes" is change to black when it is selected.

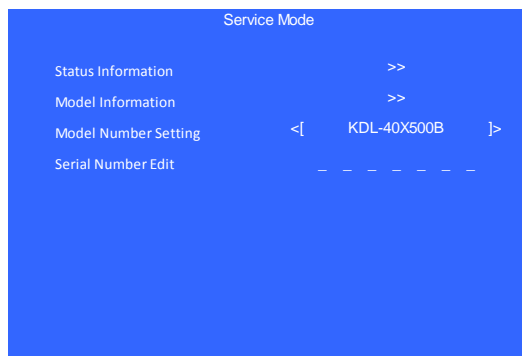

3) Serial Number can be set **ONLY ONCE**.

- After user input data , press <Enter>.
- Pop dialog will appear to inform user to confirm data.
- Press **➡** or **⬅** button to select "Yes" or "No" .
- Select "Yes" if input data is correct.
- Select "No" if input data is incorrect.
- Press <Enter> to save answer.

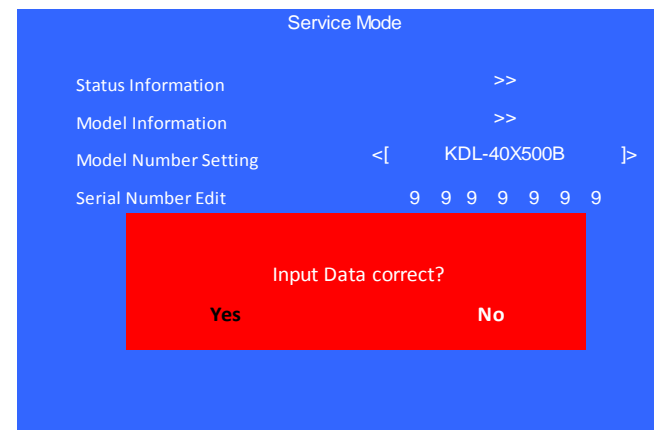

Note: * The font color of "Yes" is change to black when it is selected.

4) If **“Yes” is selected**, the input data is saved into EEPROM.

- “Serial Number Edit” is grayed out and the serial number that has been input is displayed.
- User will **not able to edit** anymore.

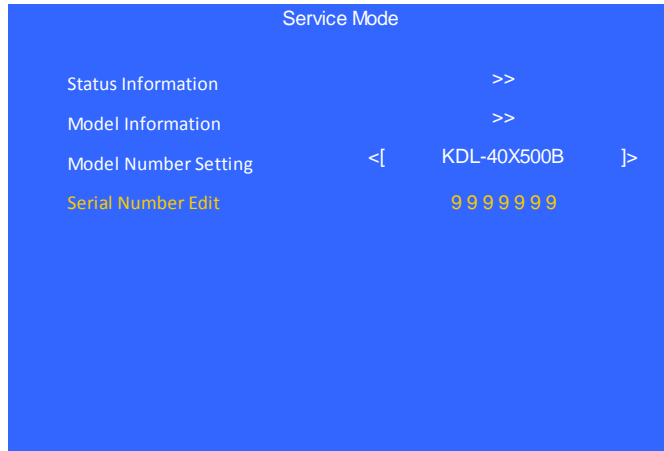

Note: * The font color of “Serial Number Edit” is change to orange after “Yes” is selected.

5) If **“No” is selected**, the input data is not saved into EEPROM.

- The serial number that has been input is displayed.
- User can still edit the Serial Number.

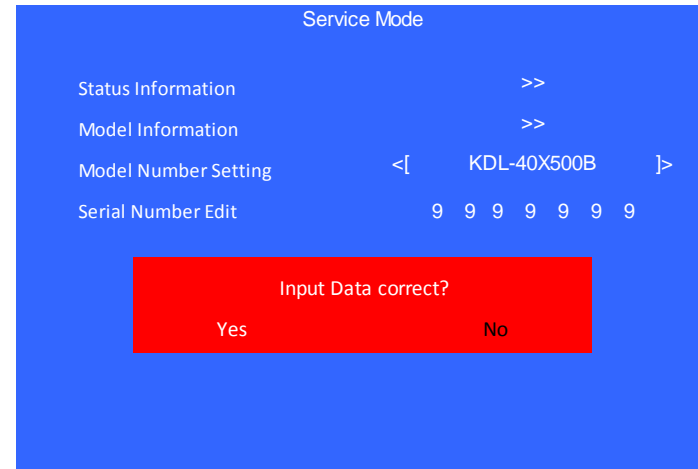

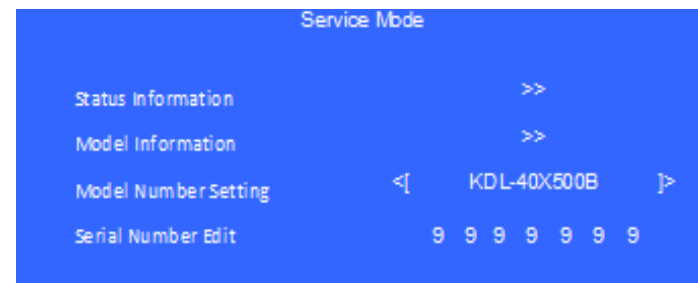

Note: * The font color of **“No”** is change to black when it is selected.







Note: * The font color of “Serial Number Edit” is white after “No” is selected.

ACCESSING MODEL NUMBER SETTING

1) In Service Mode, select “Model” pressing  button. Select “Model Number Setting” pressing  button.



- 2) Press  or  button on Remote to input numbers.
- 3) Press  or  arrow key to Product Name Candidate. (e.g. KDL-40X500B CO1, KDL-40X500C BR6)
- 4) Select one Product Name from the LIST, press  (Enter) will pop dialog to inform user to confirm data.
- 5) Press “OK” button to select YES or No.
 - Select OK if input data is correct.
 - Select NO if input data is incorrect.
 - Press <Enter> to save answer.
 - Model dependent settings will be overwritten into EEPROM.

W/B ADJUSTMENT VIA SERVICE MODE

Apply when B* board or Panel is replaced.

1) In Service Mode, select "Panel/PQ" pressing **➡** button.

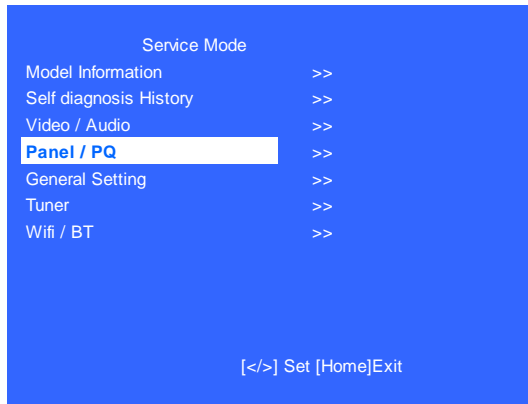

2) Go to "WB Adjustment", category by **⬆** or **⬇** button. To select "WB Adjustment", press **➡** button.

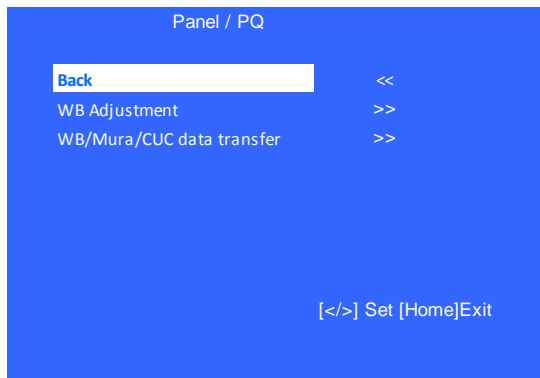

3) To change data, press **⬅** or **➡** button.





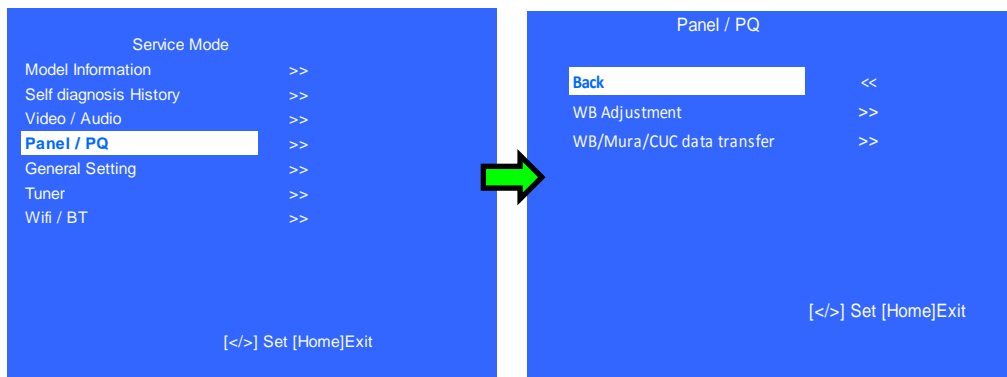

WB/MURA/CUC DATA TRANSFER VIA SERVICE MODE

Apply when B* board or Panel is replaced.

1) In "Service Mode, select "Panel/PQ" pressing  button.



2) Go to "WB/Mura/CUC data transfer", category by  or  button. To select "WB/Mura/CUC data transfer", press  button.

3) To change data, press  or  button.

4) In "WB/Mura/CUC data transfer:

a) Select "**WB/Gamma data transfer**" by pressing  or  on remote commander until cursor is on "**WB/Gamma data transfer**".

Selectable items are:

→ 0. SoC to T-con

→ T-con to SoC

→ Initialize data

b) To change the items, press  or  on remote commander.

c) Select "[Start]" and press "Enter" button to start transfer.



SEC 3. TROUBLE SHOOTING

3-1. TRIAGE CHART

Reference	Symptoms - Shutdown. Power LED blinking red diagnostics sequences									No Power	Video - missing or distorted			Remote	Network	Audio	Skype	Smart Core	Bluetooth (BT)
	2	3	4	5	6	7	8	9	10	No White Power LED & does not response to remote (Dead Set)	Stationary coloured lines or dots	No video One of Inputs	No video all Inputs	No Remote	Wireless can't connect	No Audio	Skype Can't Work	Smart Core no LED (Set is still alive)	Bluetooth / One Step Remote (OSR) can't connect
BAX Board	▲	●		▲	▲	●	●			▲	▲	●	●	▲	▲	●	▲	▲	▲
G* Board	●	▲		▲	●					●						▲			
H* Board									●					●				●	
Speaker		▲														●			
Wifi & BT Module							●								●		▲		●
LD Board			●									▲							
LVDS FFC				▲	▲						▲		▲						
Tcon			▲	●	▲				▲		▲		▲						
LCD Panel			●	●	●	▲					●		▲						
Problem	Power	Power	LD	Panel (Tcon)	Panel (Backlight)	TEMP	Software		Emitter										
		Audio				FAN (N/A)													
		Local I2C																	

- Most likely defective part
- ▲ Secondary possible defective part
- Not Applicable

Size	B* Board	G* Board	H* Board
65"	BMX	GL1SB	HSC3
75"	BMX	GL1C	HSC3

3-2. NO POWER

3-2-1. NO Power (XMH-65)

Size	B* Board	G* Board
65"	BMX	GL1SB
75"	BMX	GL1C

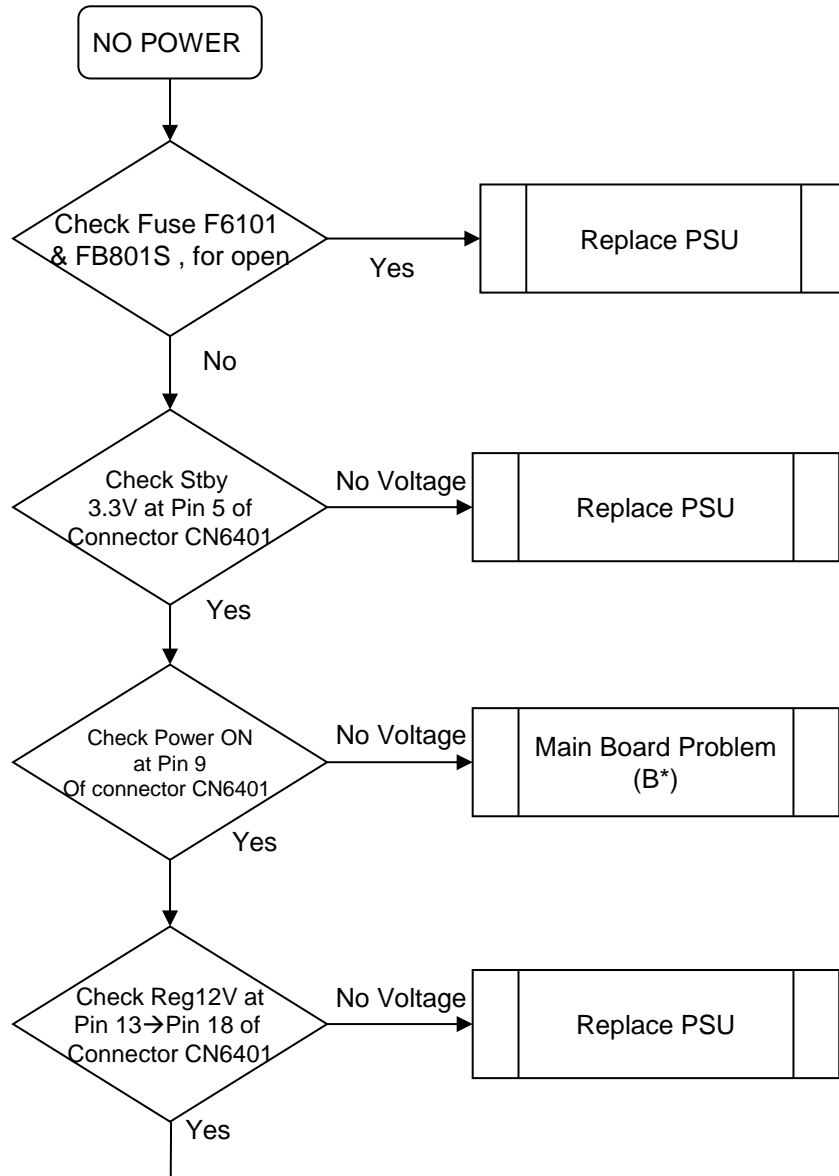

Output Name	Output Voltage	Connector CN6401
BL_ON	2.64V~3.3V	Pin 3
STBY3.3V	3.35V~3.55V	Pin 5
AC OFF DET	3.45V	Pin 7
BL_ERR	0V	Pin 8
Power_ON	2.64V~3.3V	Pin 9
REG12V	12.2V~13.2V	Pin 13→Pin 18

Output Name	Output Voltage	Connector CN5801
+OUT1	173.6V~250.3V	Pin 1
+OUT2	173.6V~250.3V	Pin 2

3-2-2. NO Power (XMH-75)

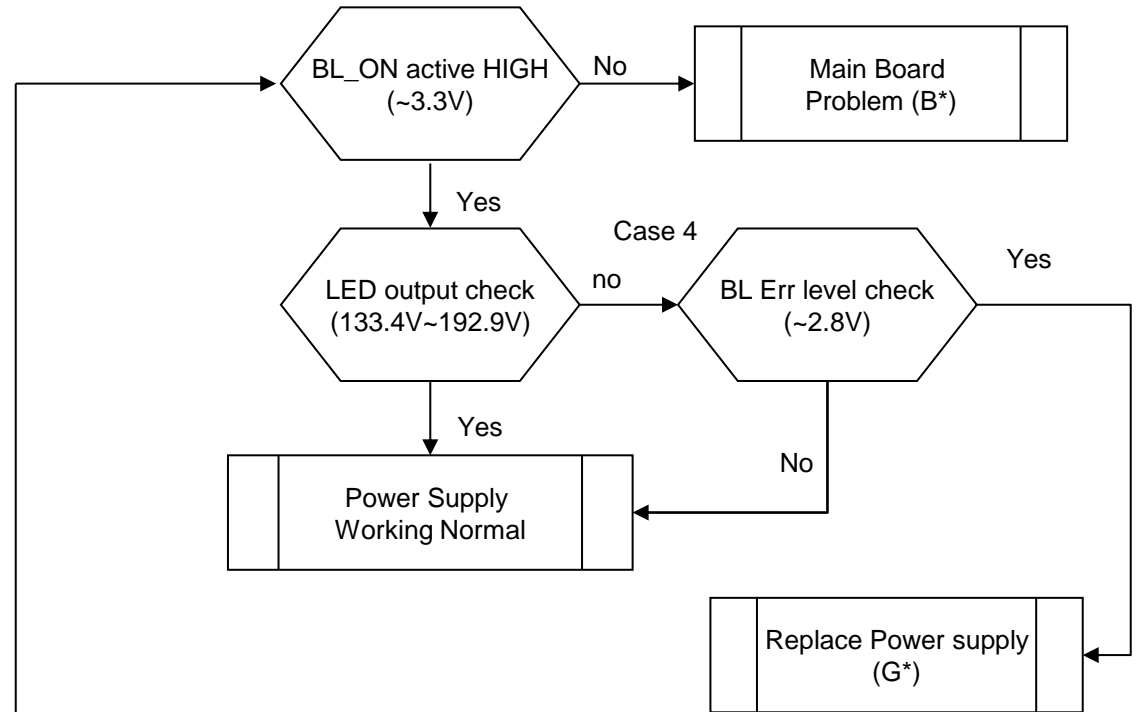
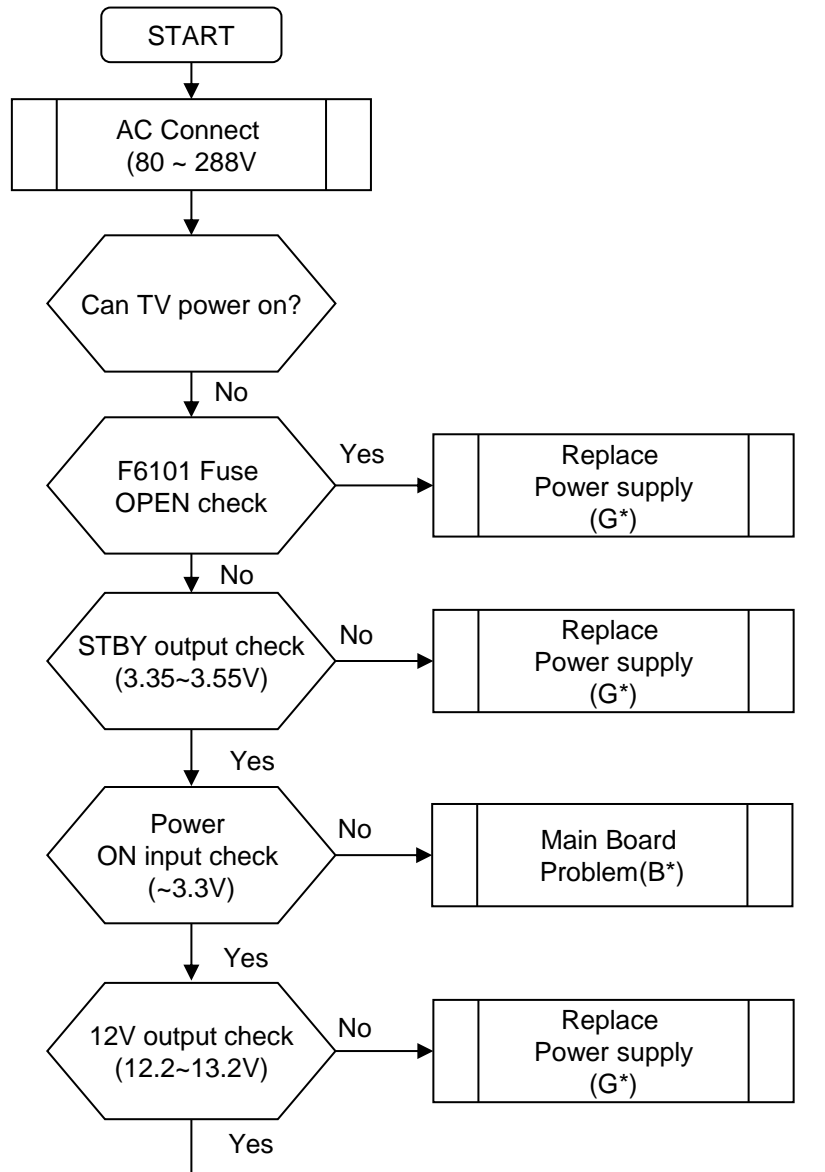

Output Name	Output Voltage	Connector CN6401
BL_ON	2.64V~3.3V	Pin 3
STBY3.3V	3.35V~3.55V	Pin 5
AC OFF DET	3.45V	Pin 7
BL_ERR	0V	Pin 8
Power_ON	2.64V~3.3V	Pin 9
REG12V	12.2V~13.2V	Pin 13→Pin 18

Output Name	Output Voltage	Connector CN5801
+OUT1	133.4V ~ 192.9V	Pin 1
+OUT2	133.4V ~ 192.9V	Pin 2
+OUT3	133.4V ~ 192.9V	Pin 3
+OUT4	133.4V ~ 192.9V	Pin 4

Size	B* Board	G* Board
65"	BMX	GL1SB
75"	BMX	GL1C

3-2-3. NO Power (DC/DC Converter Check)

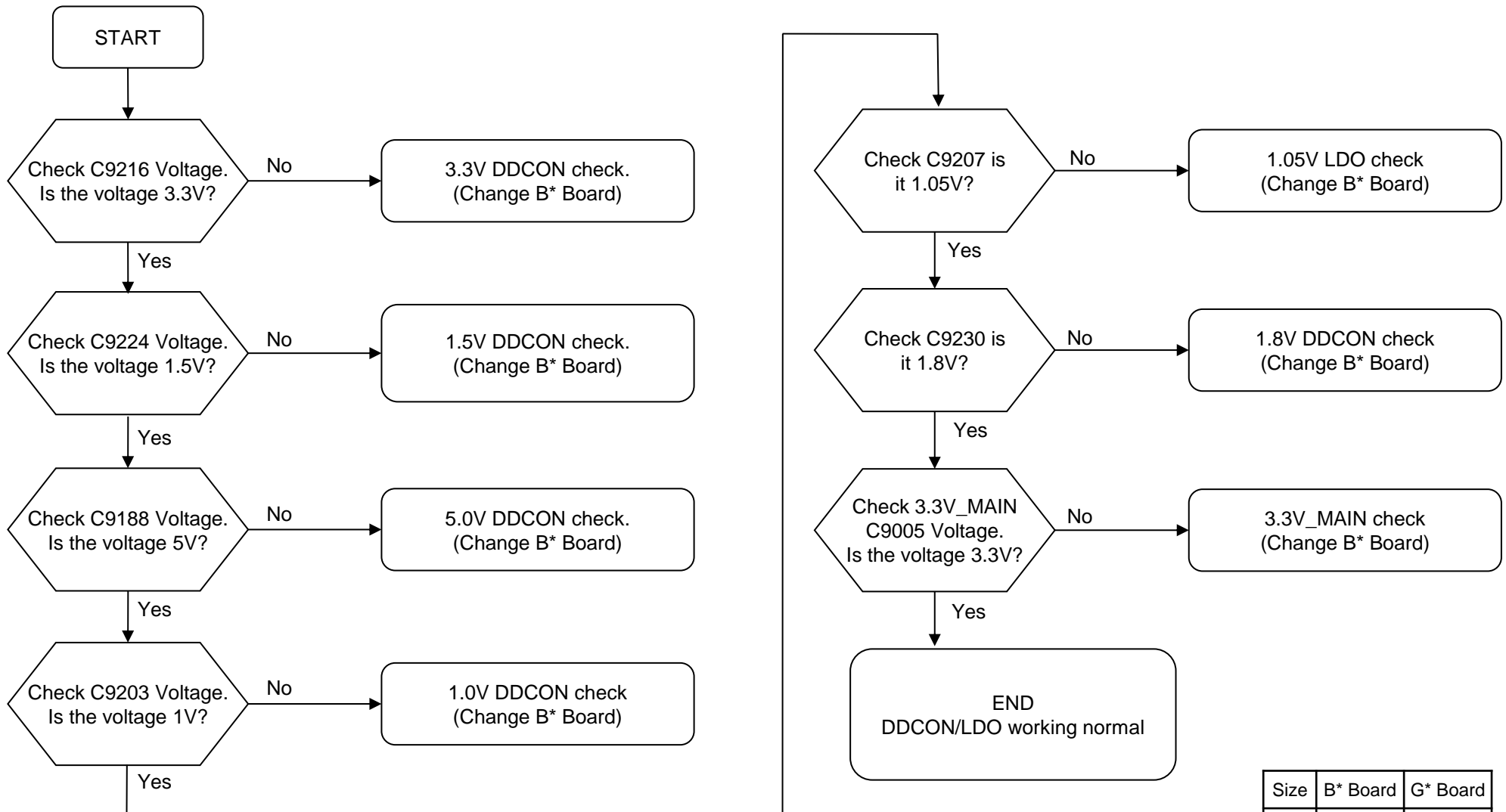

Size	B* Board	G* Board
65"	BMX	GL1SB
75"	BMX	GL1C

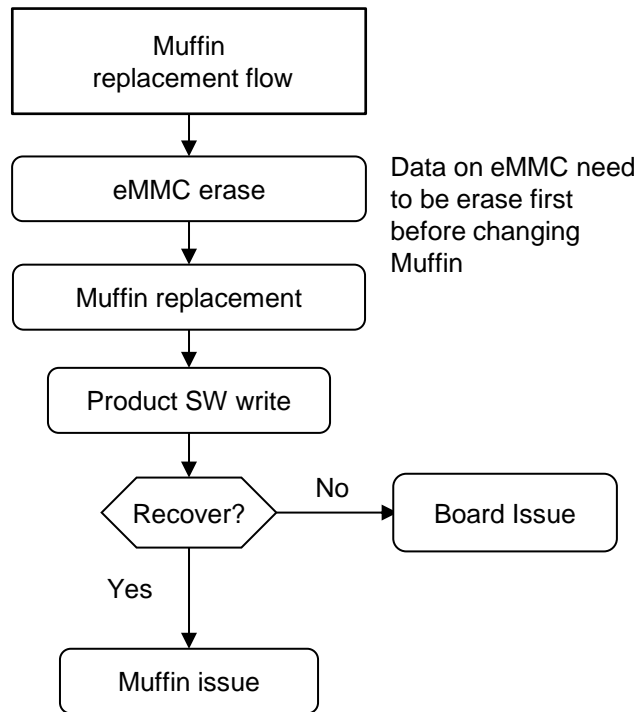
3-2-4. NO Power (Muffin Replacement (Main Device))

3-3. LED BLINKING

1) 2 times blinking (Main Power Error)

BMX board (XM-H) only → G* Board

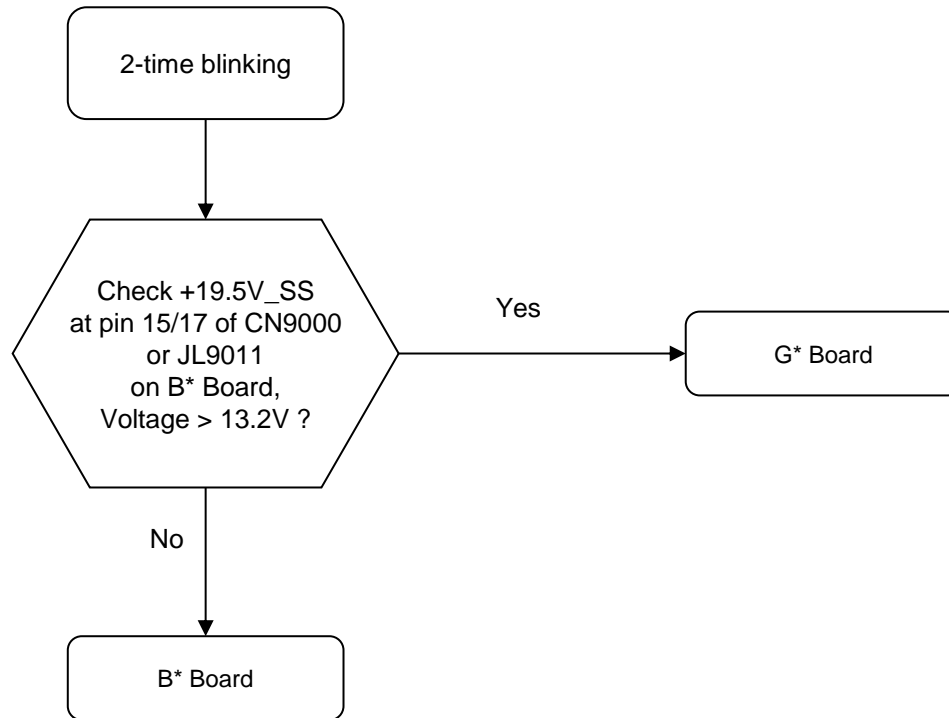

Size	B* Board	G* Board
65"	BMX	GL1SB
75"	BMX	GL1C

2) 3 times blinking (DC Alert & Communication Error)

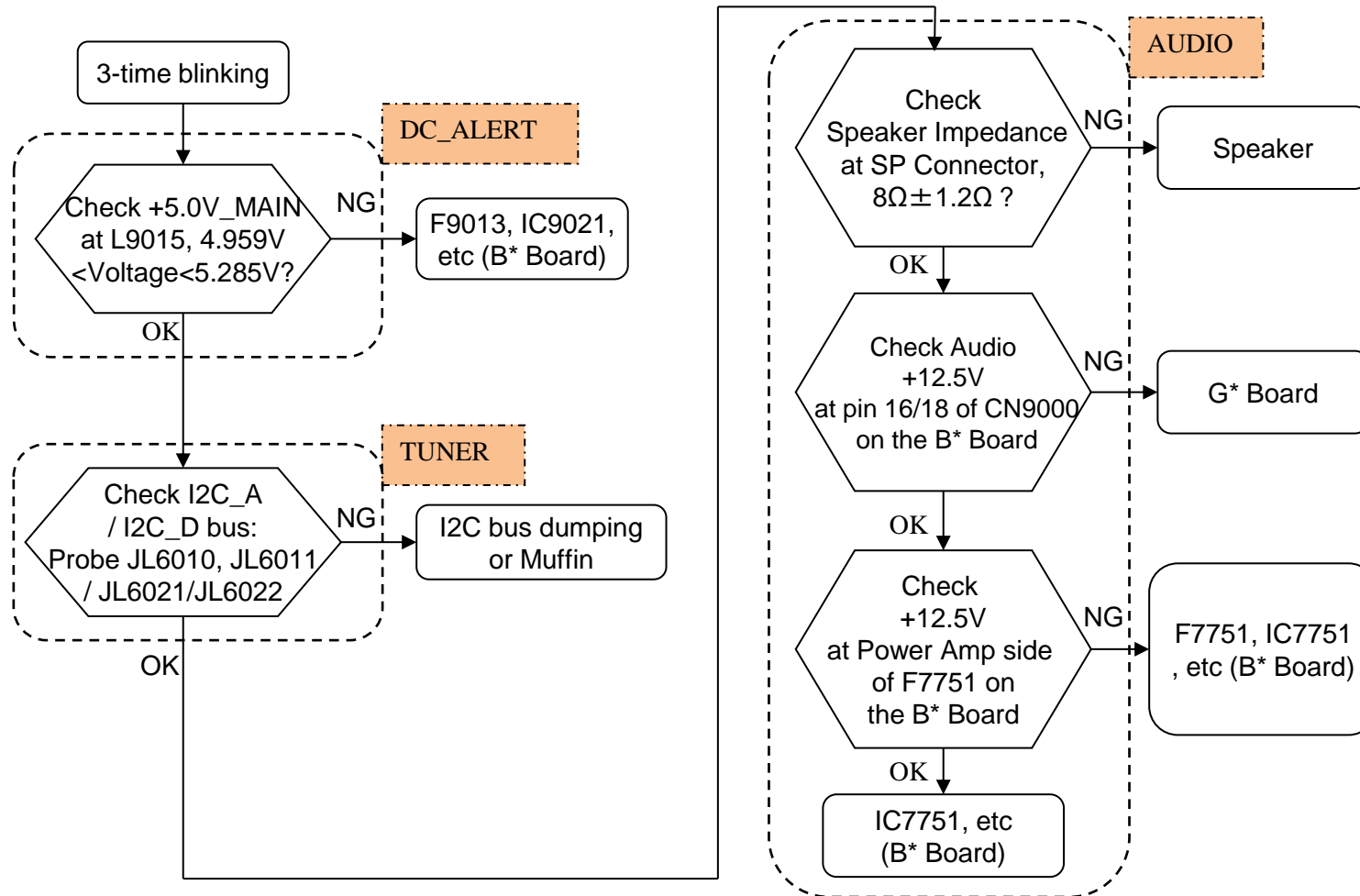

Size	B* Board	G* Board
65"	BMX	GL1SB
75"	BMX	GL1C

3) 5 times blinking (Panel Communication Error (12.5V NG))

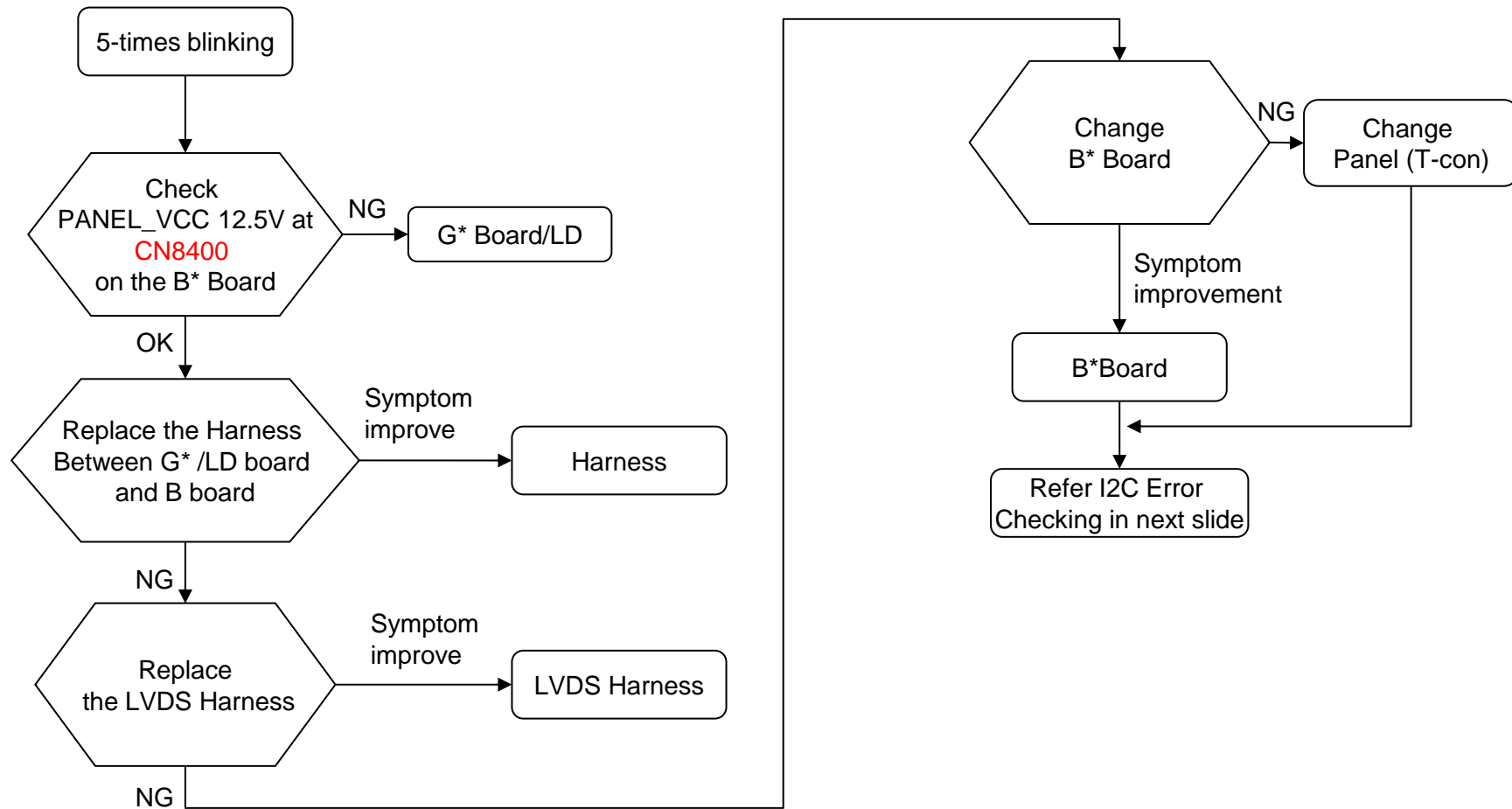

Size	B* Board	G* Board
65"	BMX	GL1SB
75"	BMX	GL1C

4) 5 times blinking (Panel Communication Error (I2C Error))

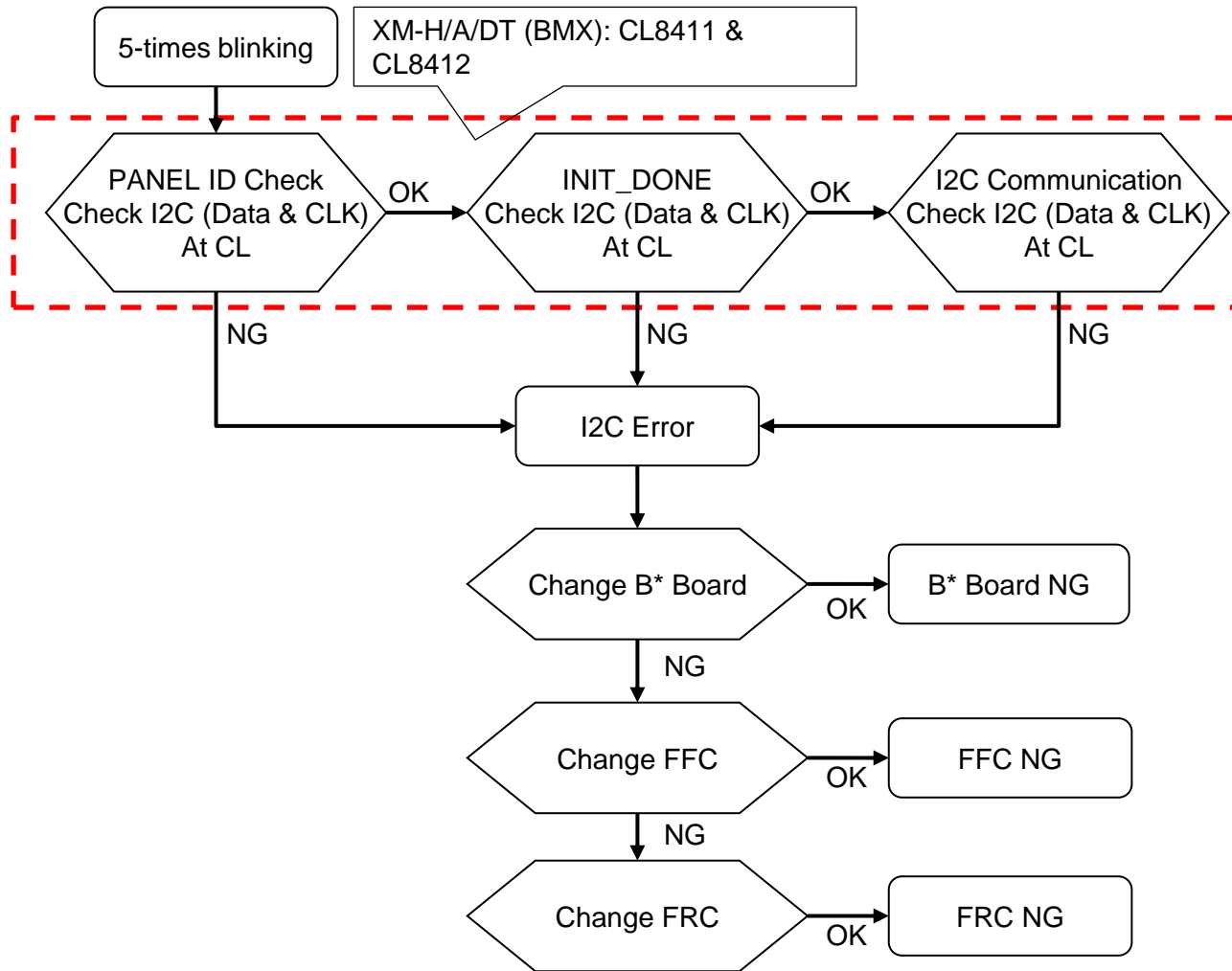

Size	B* Board	G* Board
65"	BMX	GL1SB
75"	BMX	GL1C

5) 6 times blinking (Backlight Error)

Size	B* Board	G* Board
65"	BMX	GL1SB
75"	BMX	GL1C

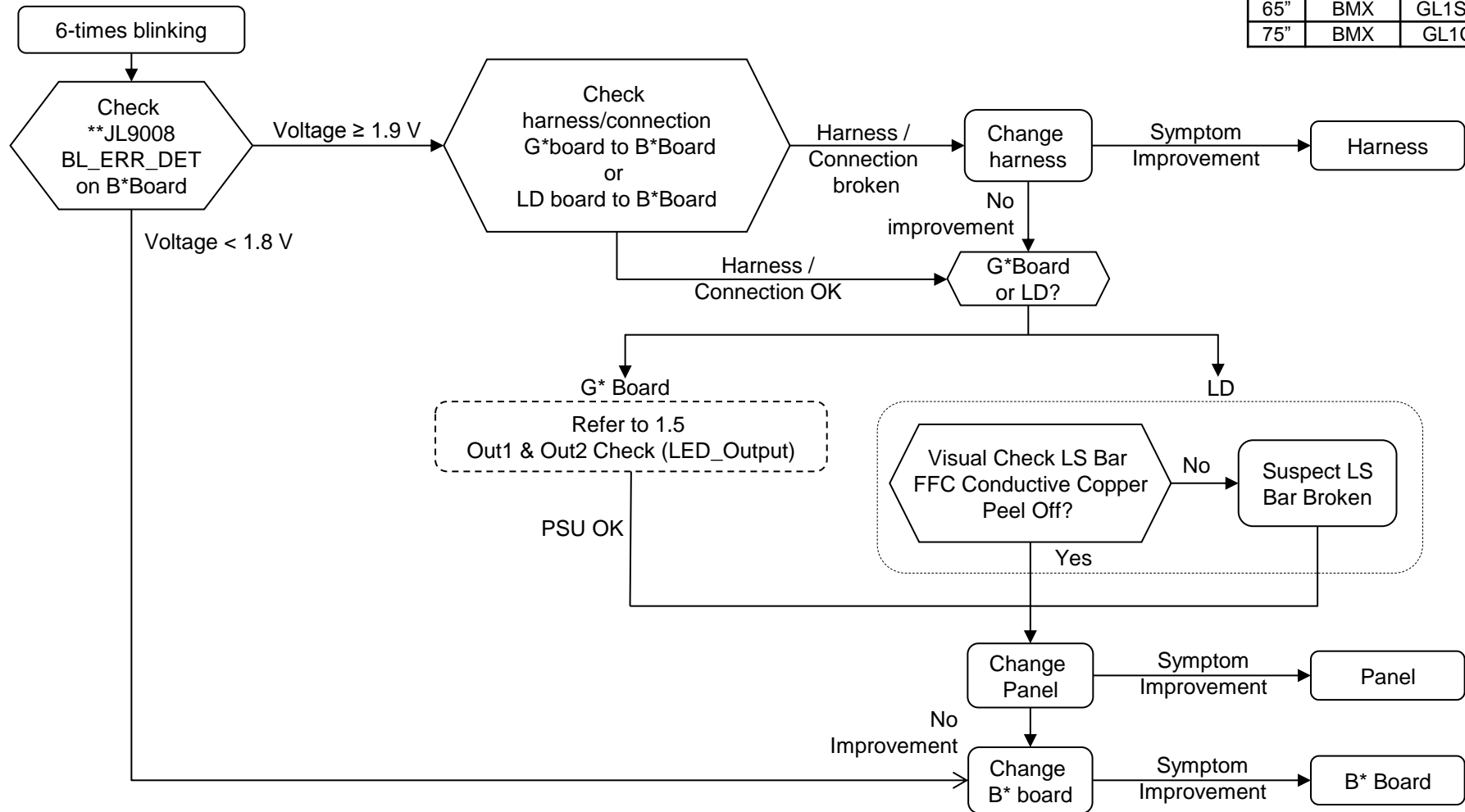

**BMX: JL9008 BL_ERR_DET

6) 7 times blinking (Temperature Error)

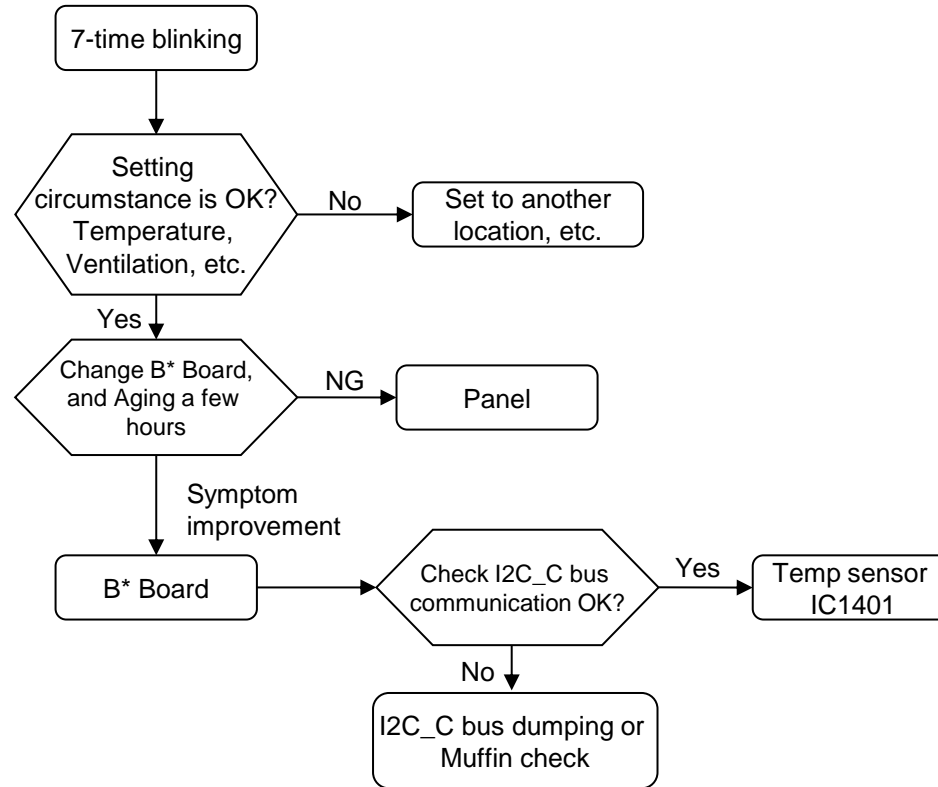

Size	B* Board	G* Board
65"	BMX	GL1SB
75"	BMX	GL1C

3-4. NO PICTURE

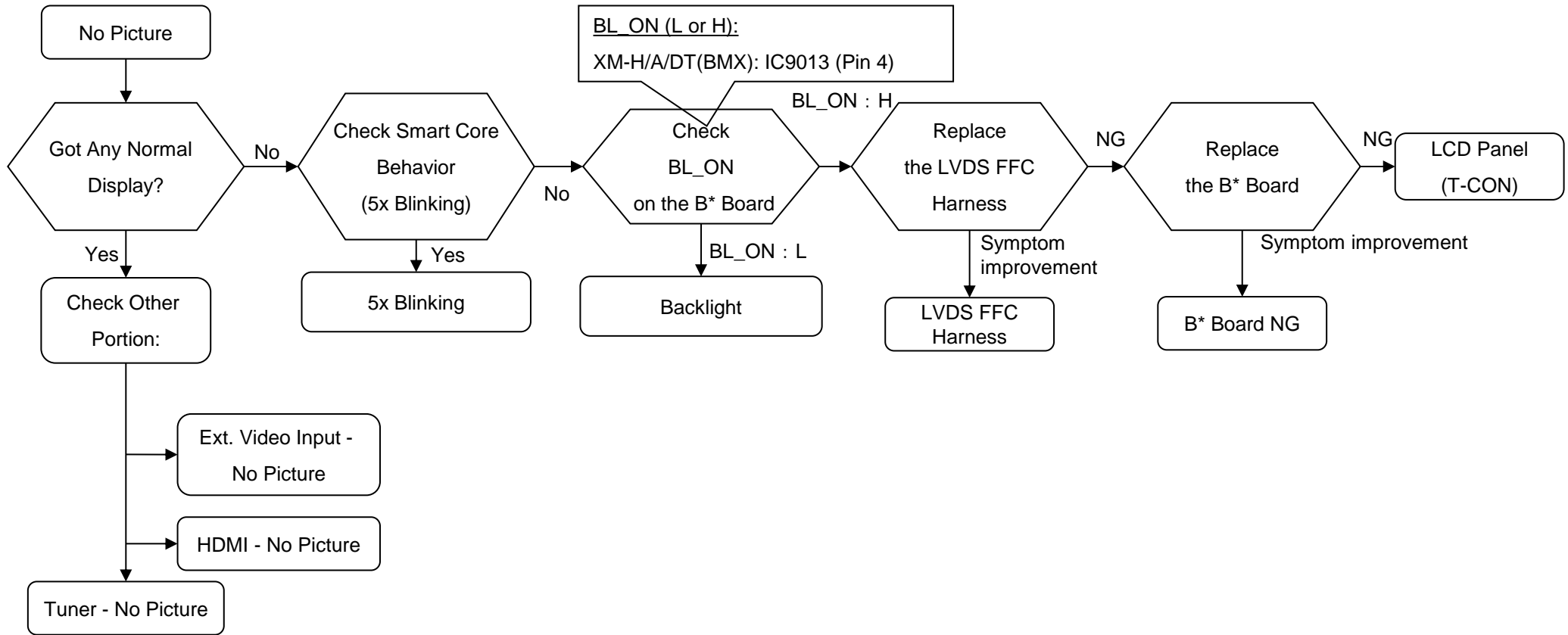

Size	B* Board	G* Board
65"	BMX	GL1SB
75"	BMX	GL1C

3-5. NO SOUND

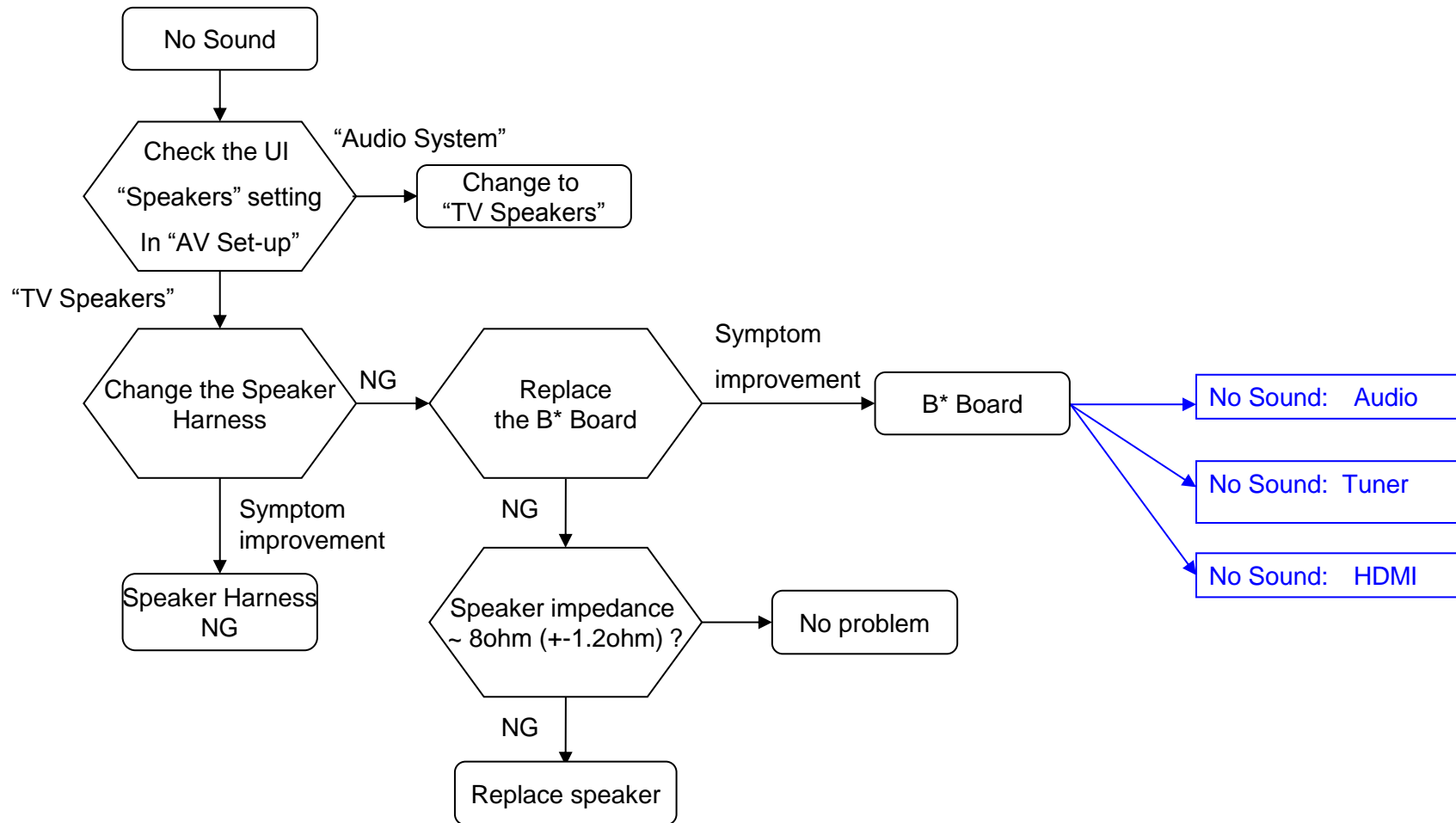

Size	B* Board	G* Board
65"	BMX	GL1SB
75"	BMX	GL1C

3-6. SIDE BUTTONS MALFUNCTION

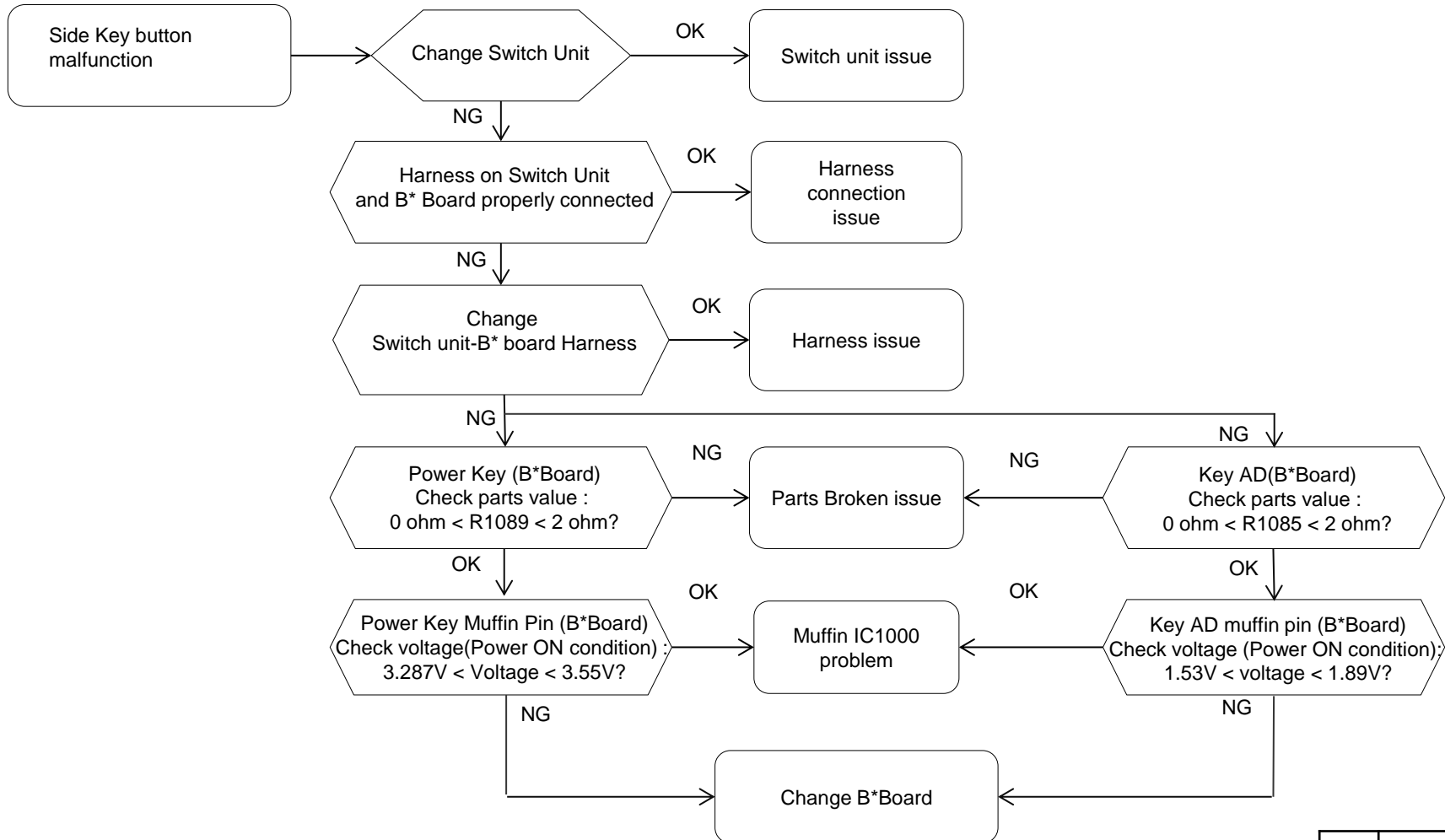

Size	B* Board	G* Board
65"	BMX	GL1SB
75"	BMX	GL1C

3-7. IR REMOTE COMMANDER MALFUNCTION

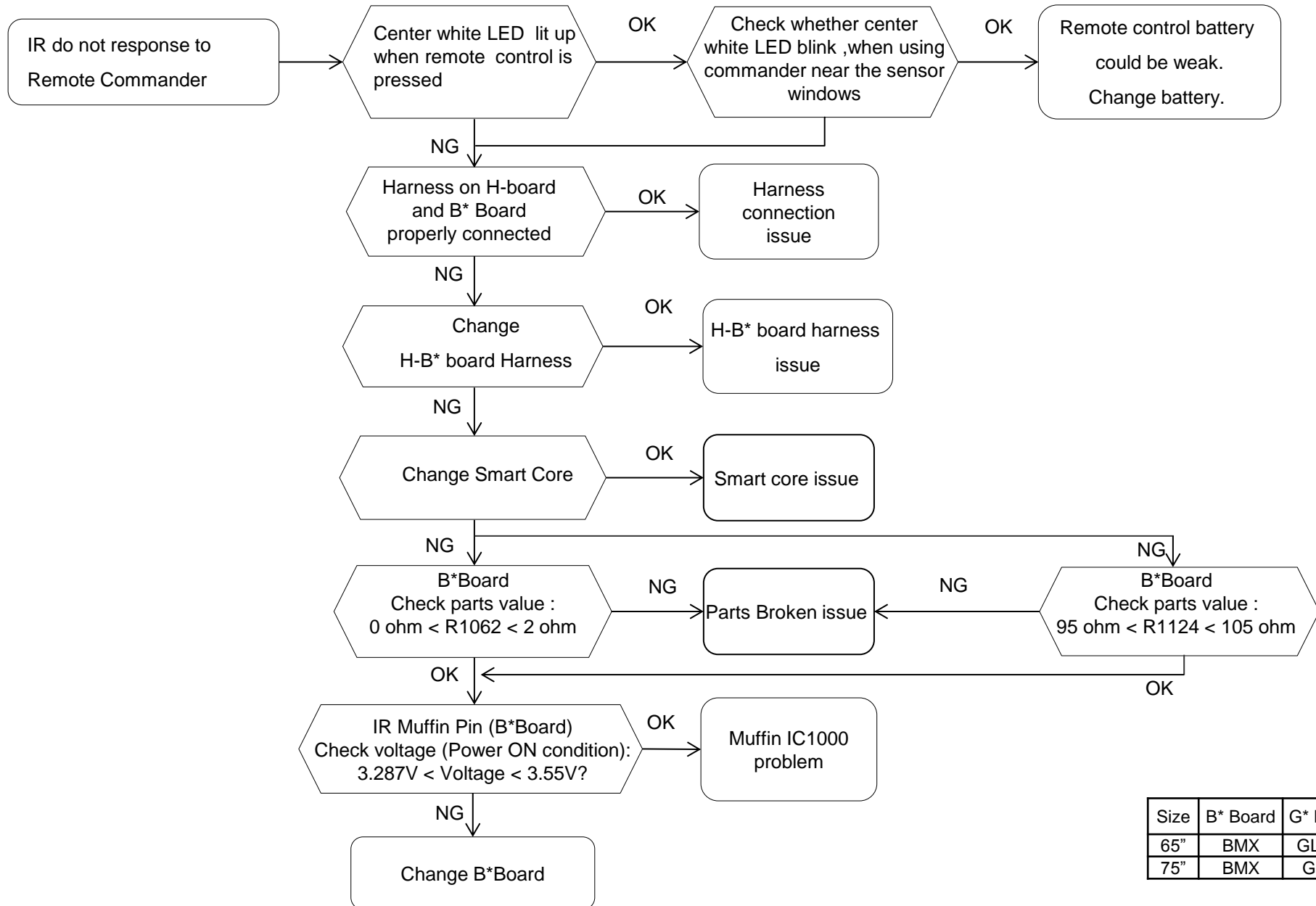

Size	B* Board	G* Board
65"	BMX	GL1SB
75"	BMX	GL1C

3-8. LIGHT SENSOR ERROR

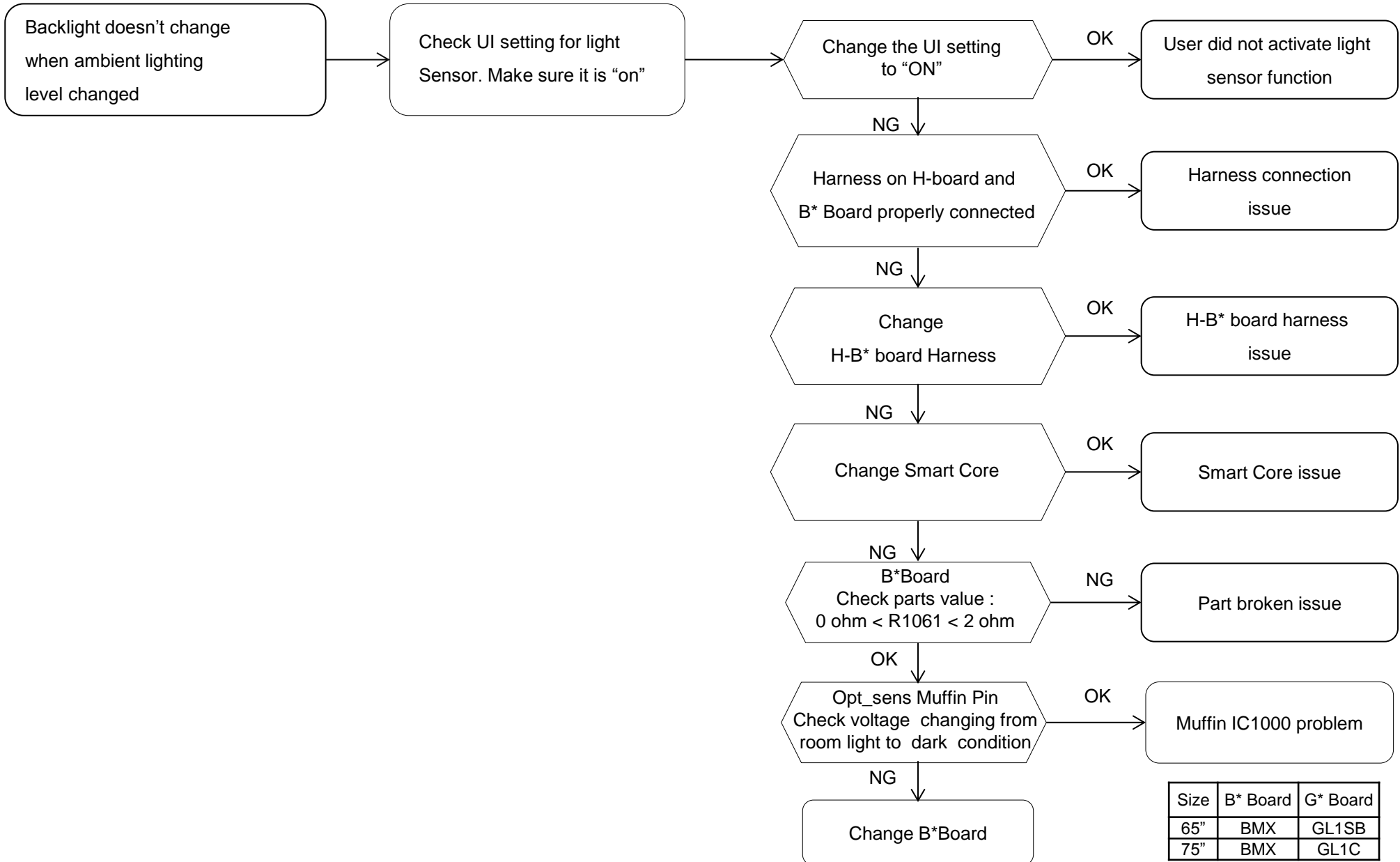

Size	B* Board	G* Board
65"	BMX	GL1SB
75"	BMX	GL1C

3-9. NETWORK MALFUNCTION(Ethernet (Wired))

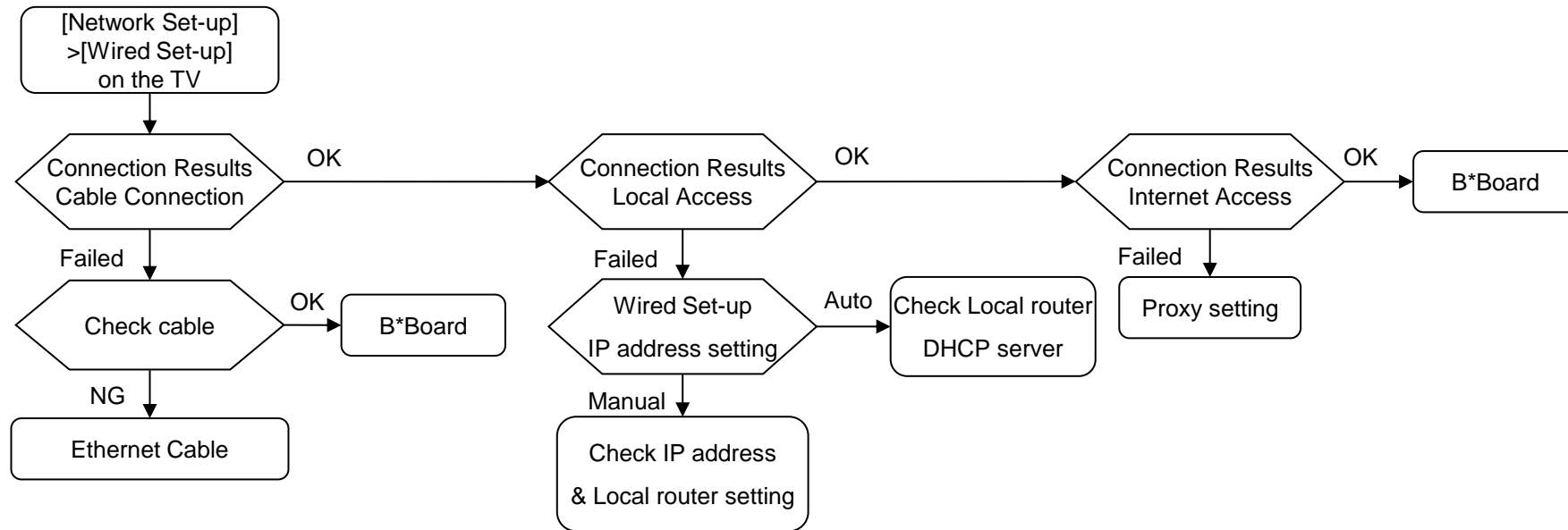

Size	B* Board	G* Board
65"	BMX	GL1SB
75"	BMX	GL1C

3-10. WIRELESS NETWORK MALFUNCTION

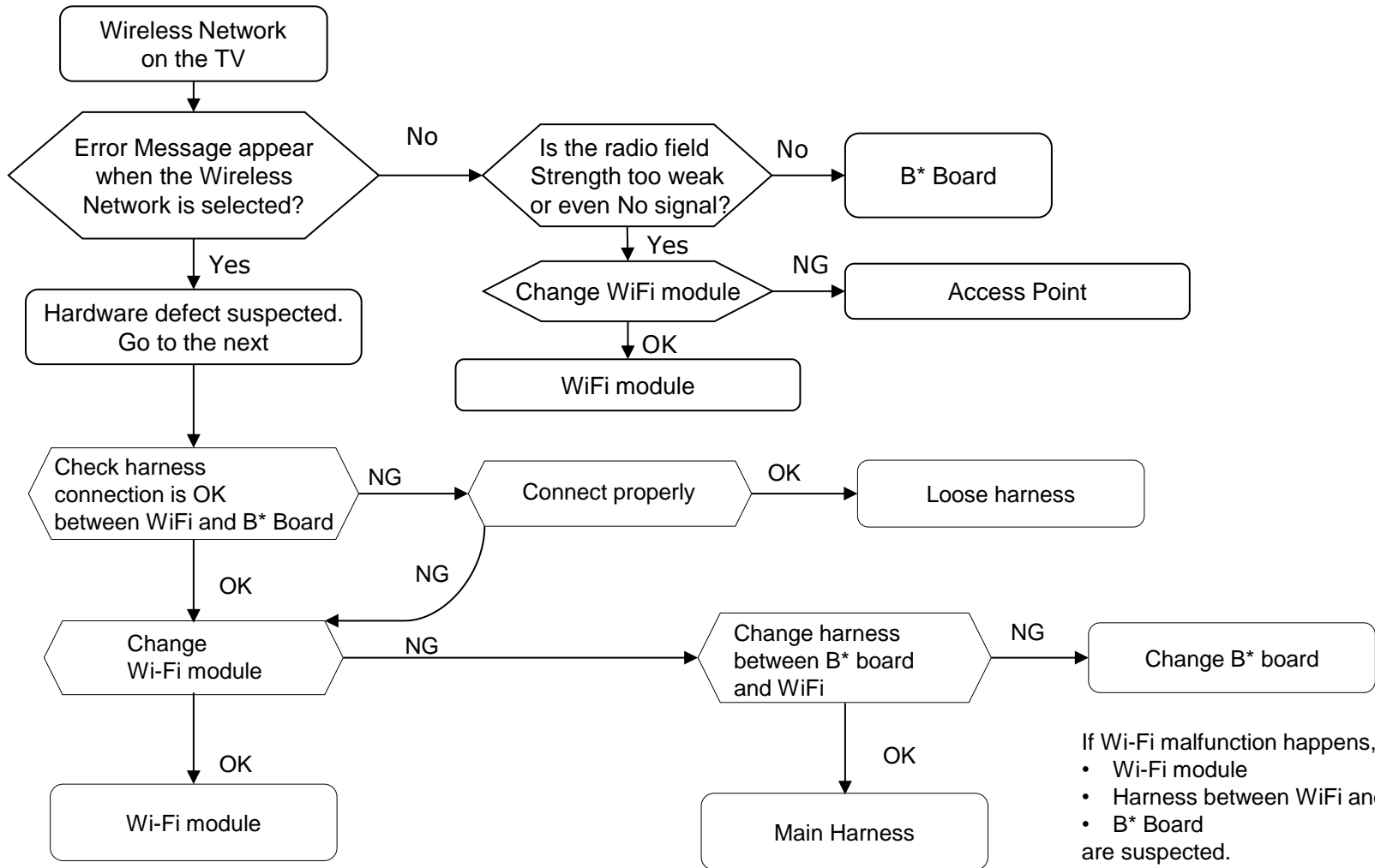

If Wi-Fi malfunction happens,
 • Wi-Fi module
 • Harness between WiFi and B* Board
 • B* Board
 are suspected.

Size	B* Board	G* Board
65"	BMX	GL1SB
75"	BMX	GL1C

3-11. BLUETOOTH MALFUNCTION

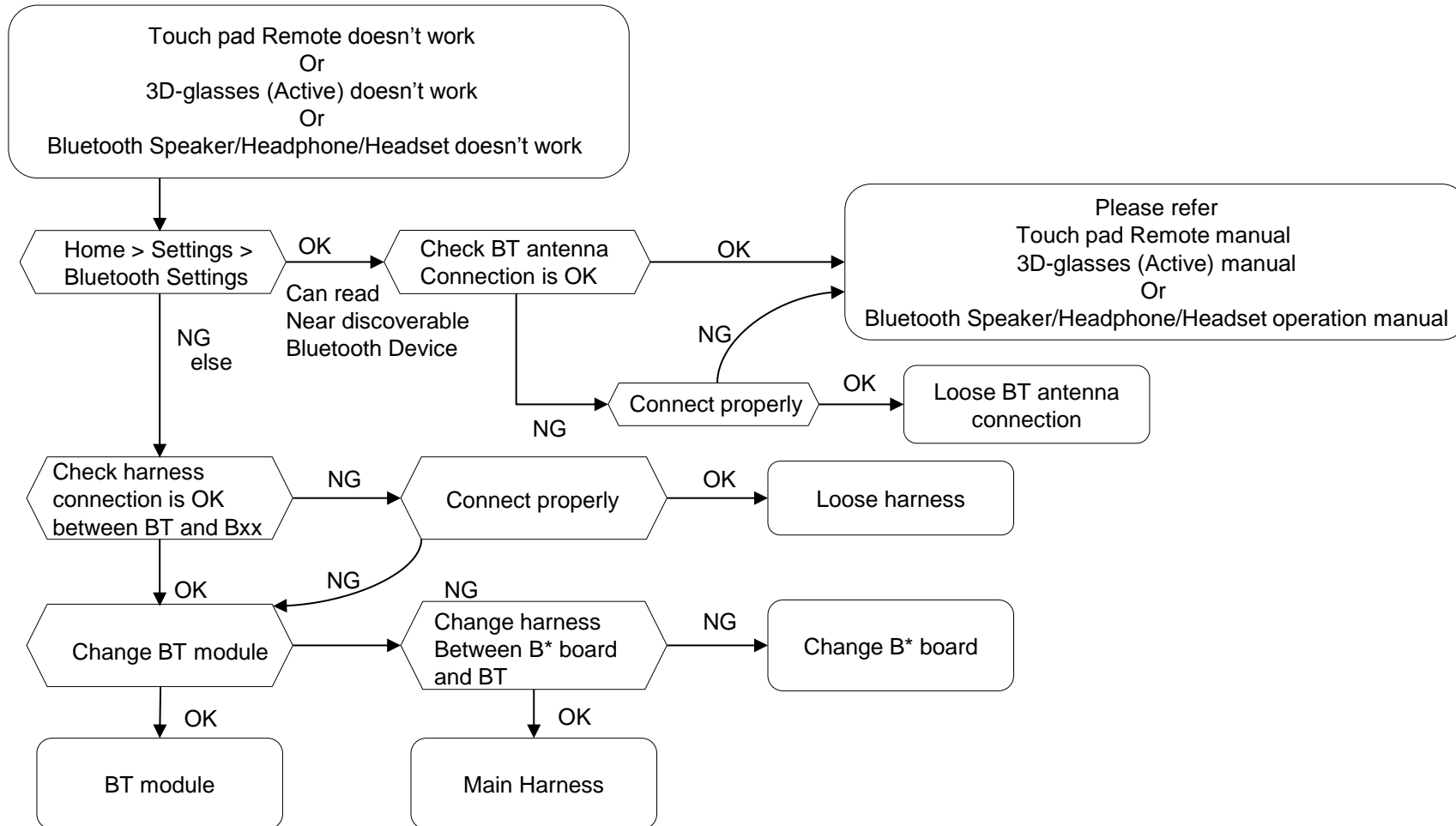

Size	B* Board	G* Board
65"	BMX	GL1SB
75"	BMX	GL1C

SEC 4. DIAGRAMS

4-1. BLOCK DIAGRAM

4-1-1. BR, AR, LA Model

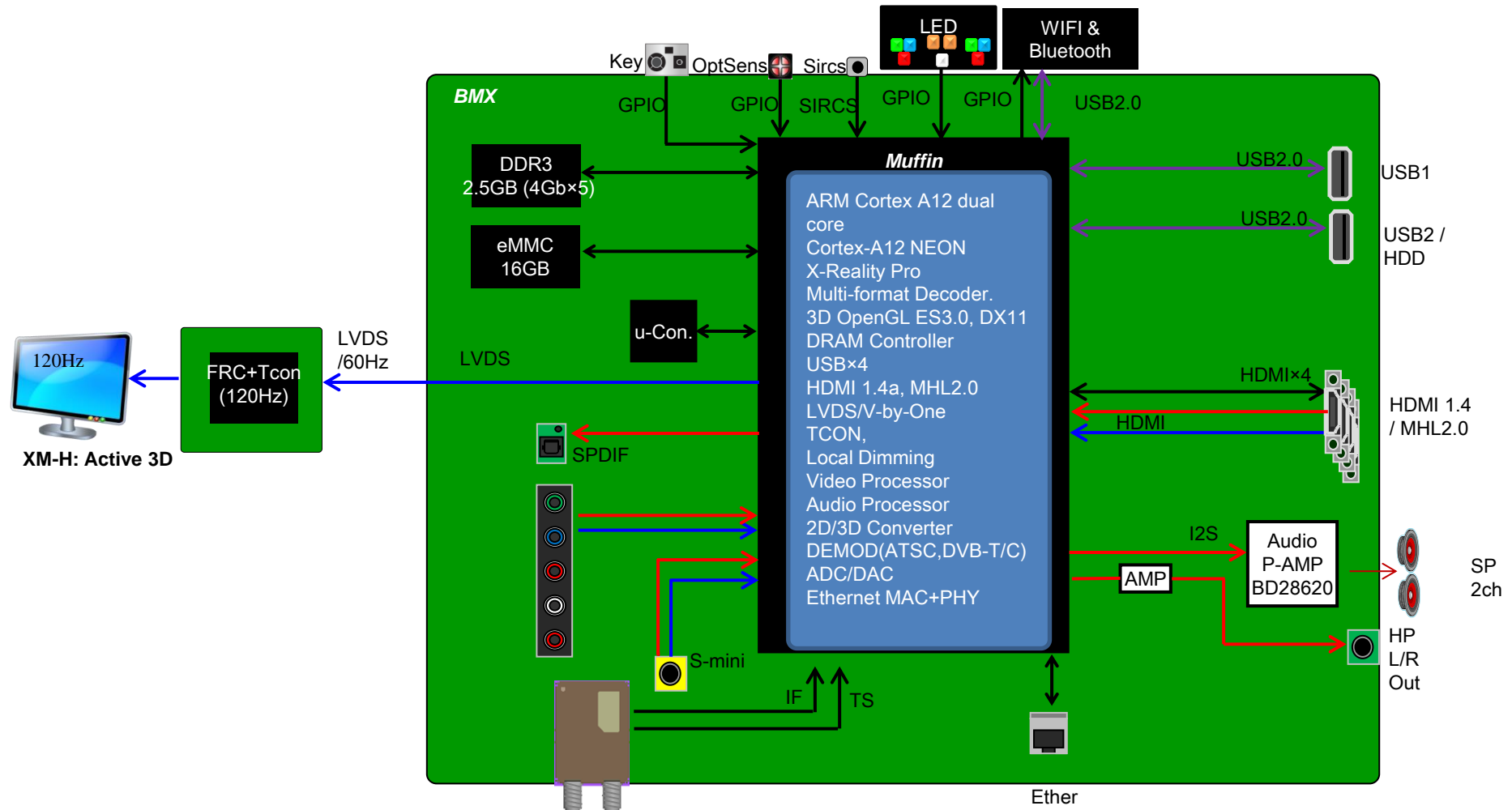

4-1-2. UC Model

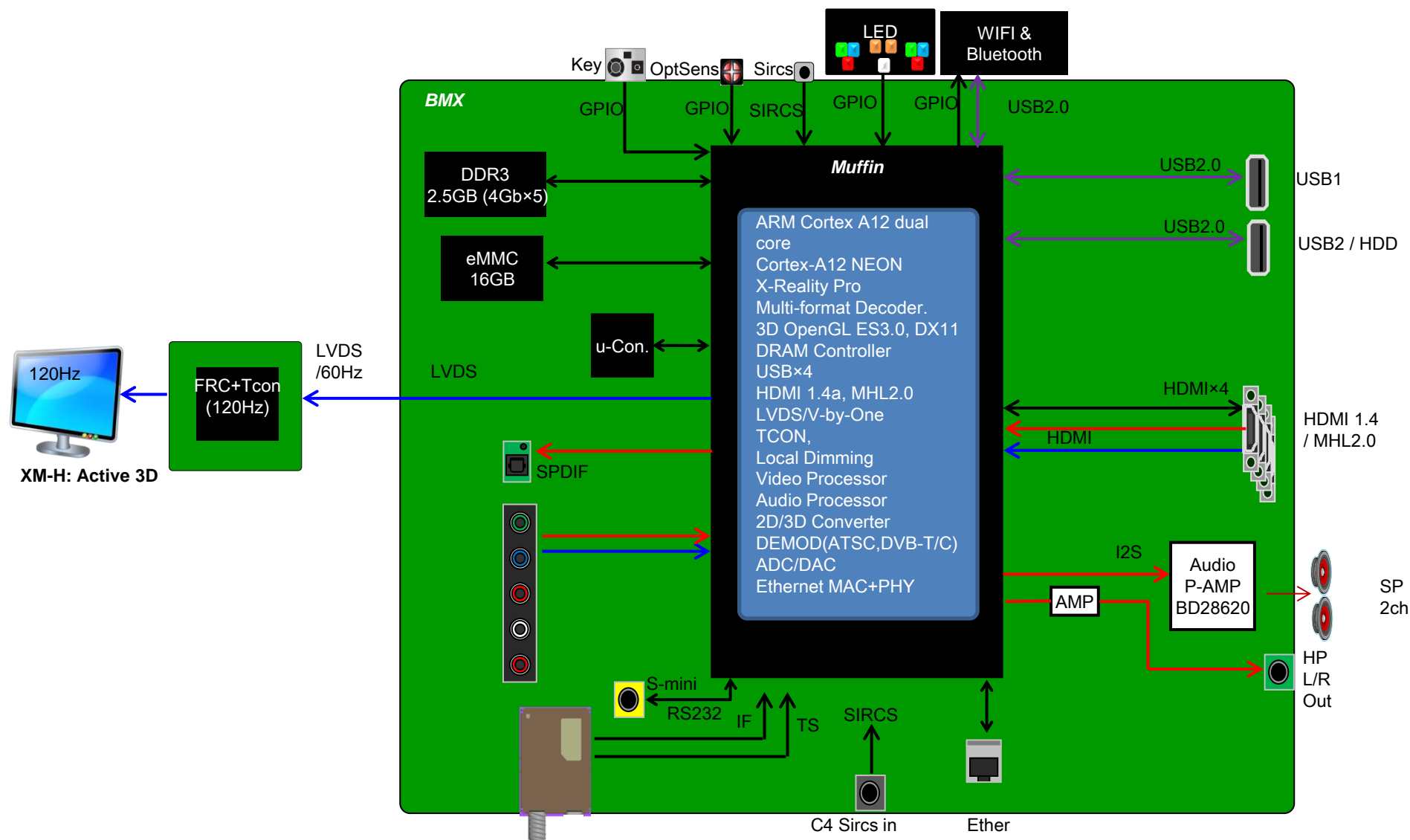

4-2. CONNECTOR DIAGRAM

4-2-1. 65 Inch Model

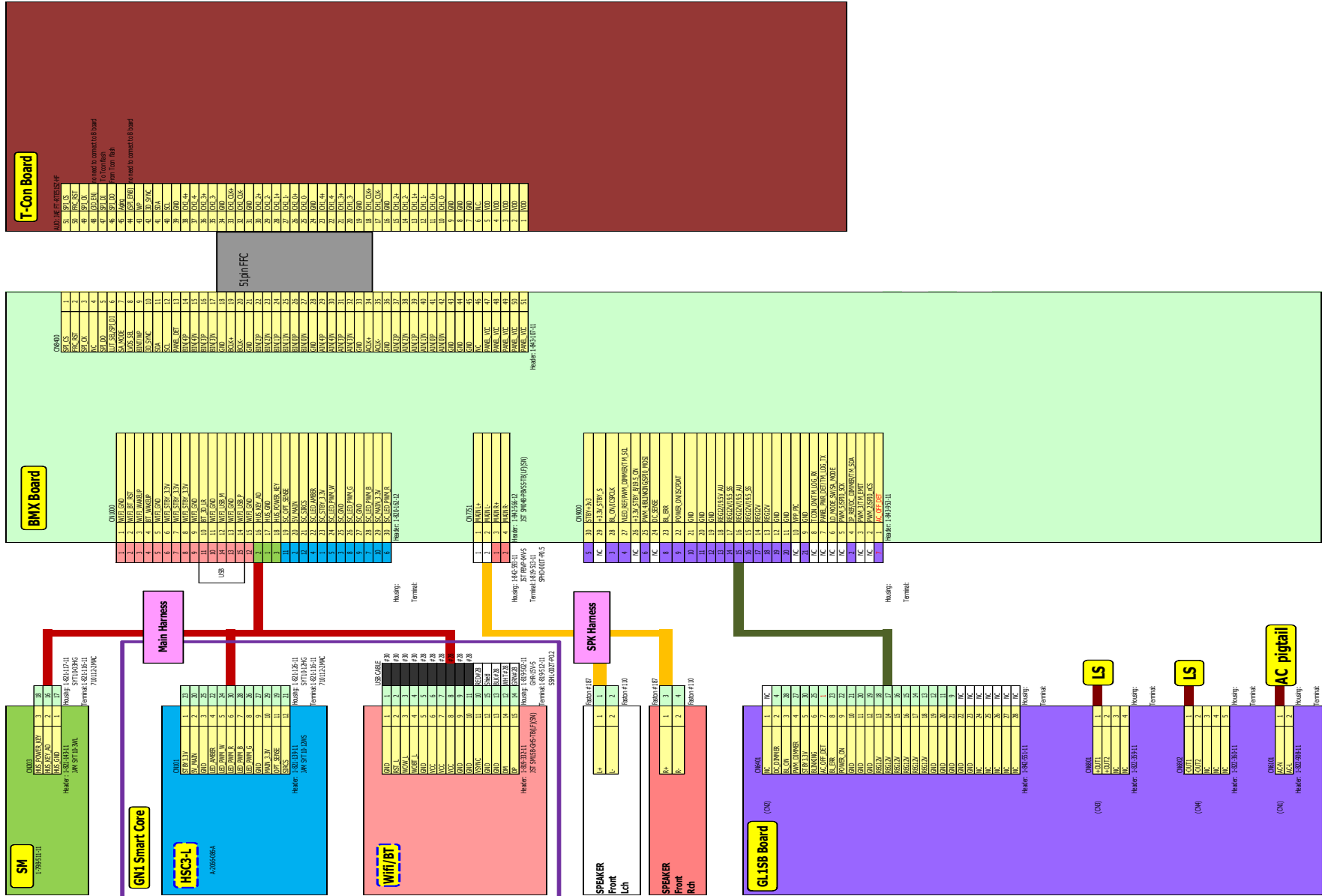

4-2-2. 75 Inch Model

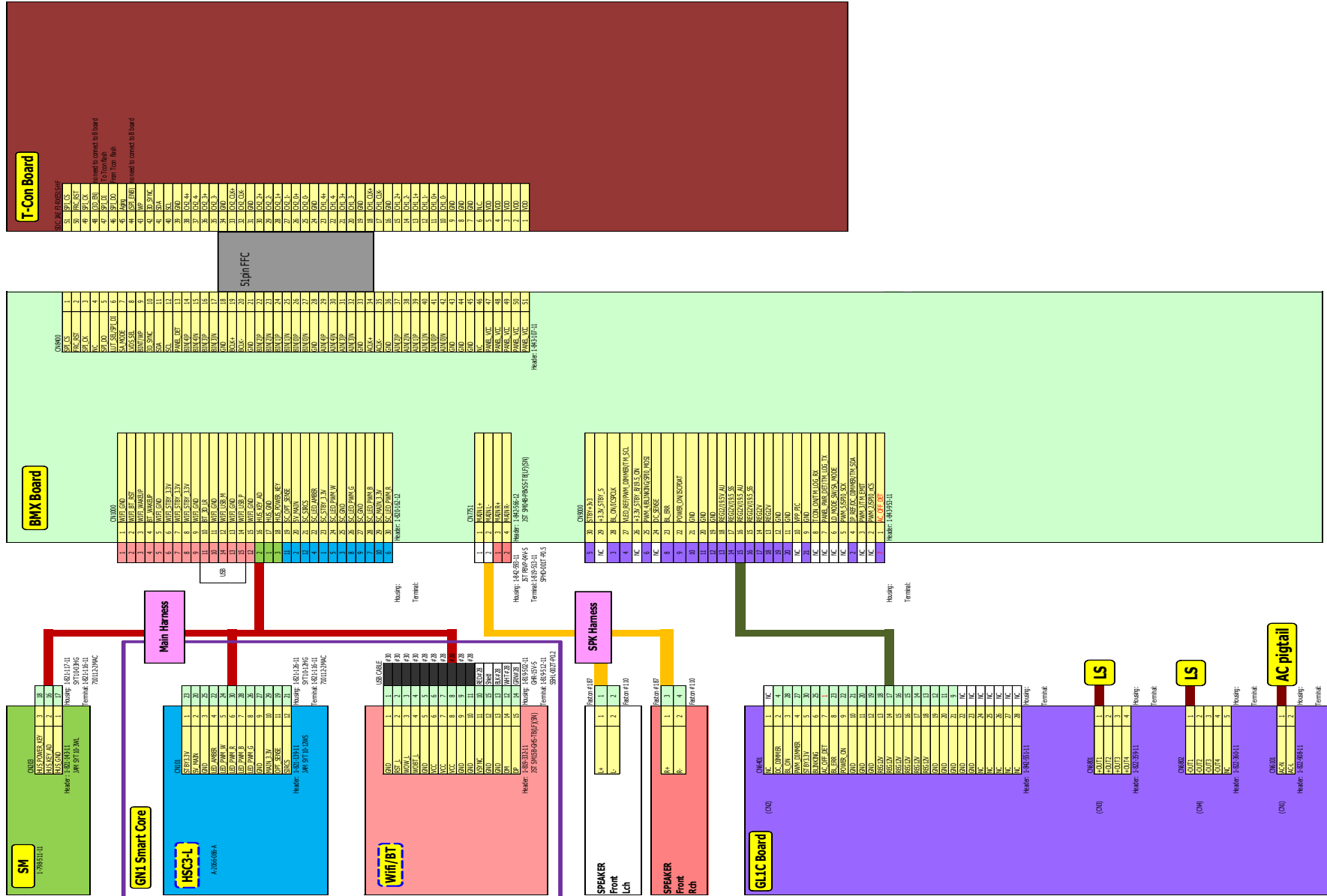

4-3. CIRCUIT BOARDS LOCATION

4-3-1. KDL-65W850C/855C/857C

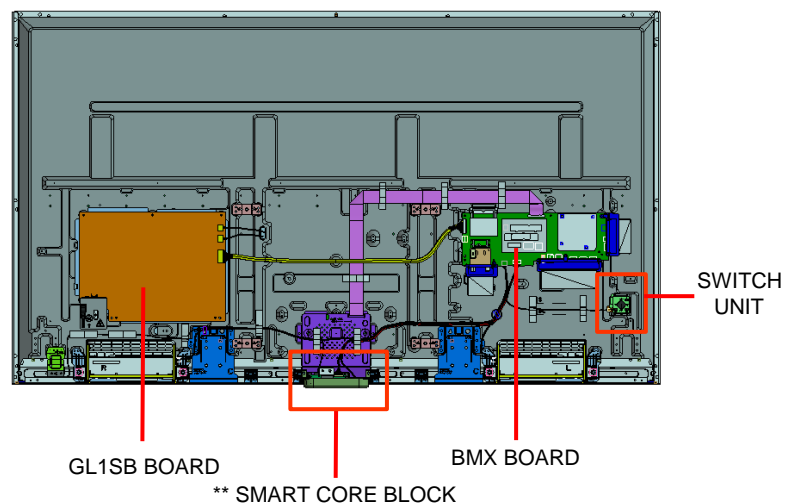

4-3-2. KDL-75W850C/855C

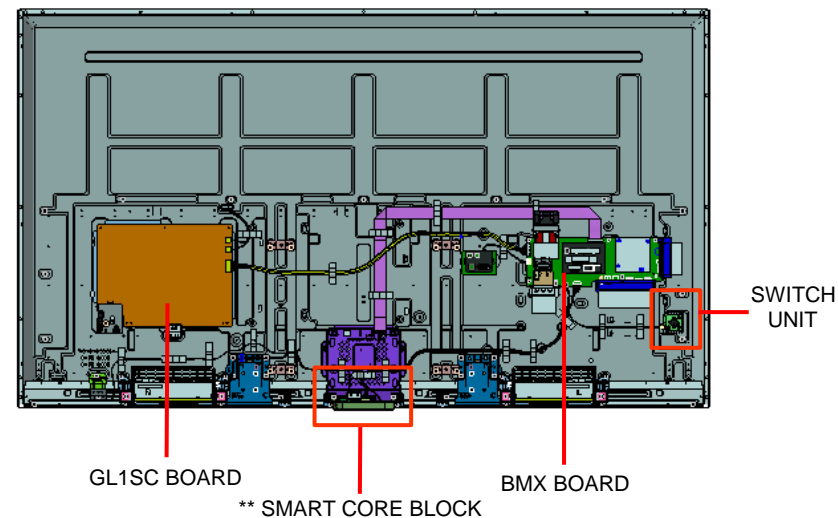

<** SMART CORE BLOCK >

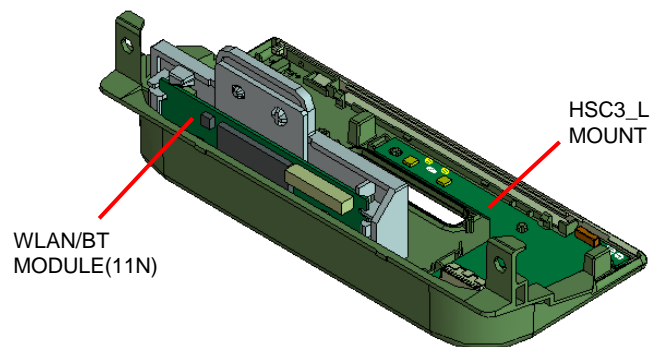

4-4. Wire Dressing

4-4-1. Wire Dressing (Caution for Flexible Flat Cable)

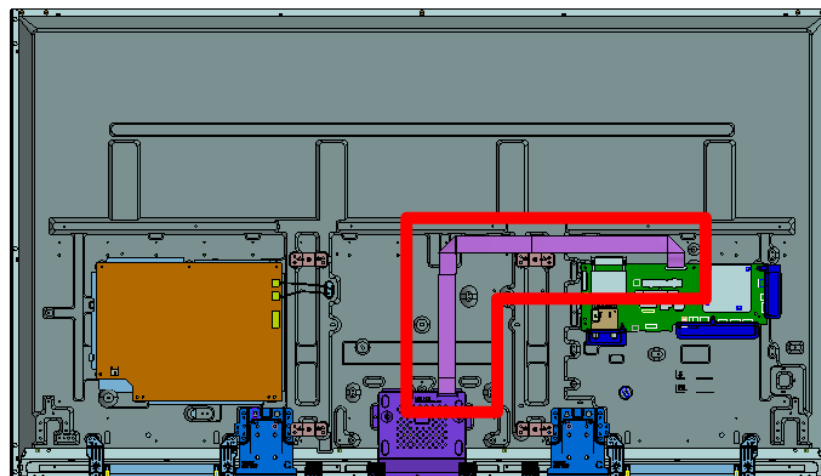

Caution during handling Flexible Flat Cable

<p>OK and NG Conditions for FFC insertion</p> <div style="display: flex; justify-content: space-between;"> <div style="width: 45%;"> <p>OK</p> <p>Insert FFC in straight direction/condition into the connector and plunge it to the depths.</p> </div> <div style="width: 45%;"> <p>NG</p> <p>DO NOT slant the FFC during insertion.</p> </div> </div>	<p>Caution for FFC with connector installation at panel side</p> <div style="display: flex; justify-content: space-around;"> <div style="width: 45%;"> <p>OK</p> </div> <div style="width: 45%;"> <p>NG</p> </div> </div> <p>Abnormal handling will cause contact shifted & foreign particles issue as picture below:</p> <div style="display: flex; justify-content: space-around;"> </div>	<p>Caution: For Reverse Insertion (180° degree Turn & Insert)</p> <div style="display: flex; justify-content: space-between;"> <div style="width: 45%;"> <p>OK</p> <p>1) Hold FFC holder & FFC by using two hands</p> <p>2) Insert FFC to main board straight and as parallel to main board (allowance : within 30 degree)</p> <p>Side view</p> </div> <div style="width: 45%;"> <p>NG</p> <p>1) Hold FFC by holder only (wrong handling).</p> <p>2) Side view</p> <p>2) FFC cover flip/slanting (> 30 degree)</p> </div> </div>
--	---	--

4-4-2. Wire Dressing (Insert Connector & Tape (FFC))

Insert Connector

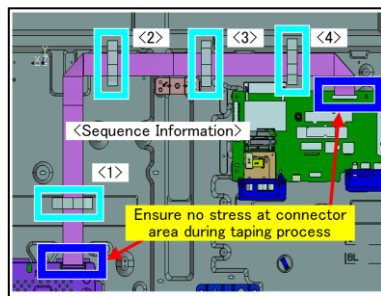
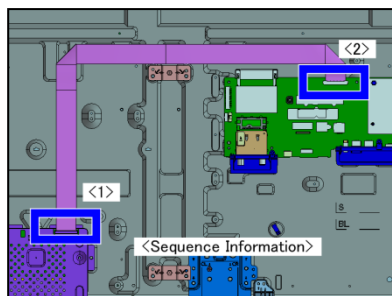
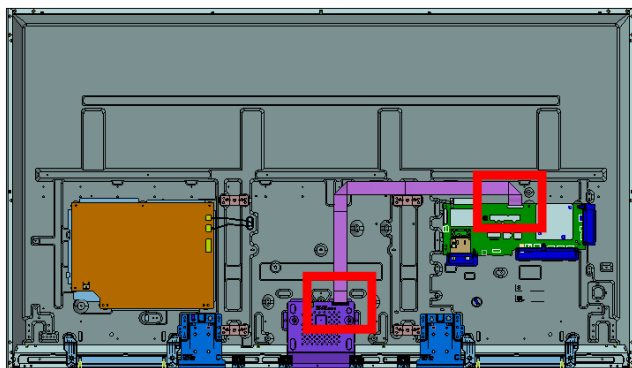

Insert Tape

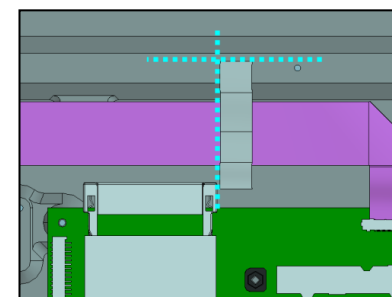
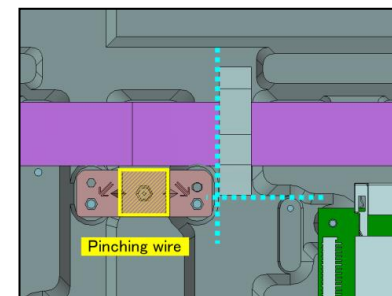
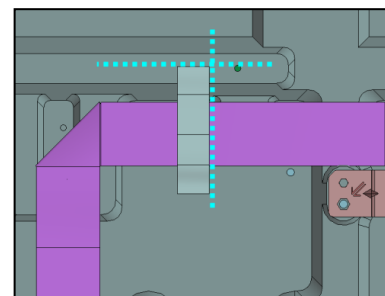
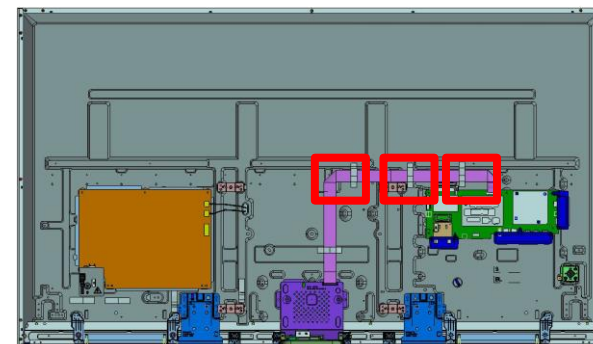

4-4-3. Wire Dressing (Insert Connector, Tape & Hook(Harness))

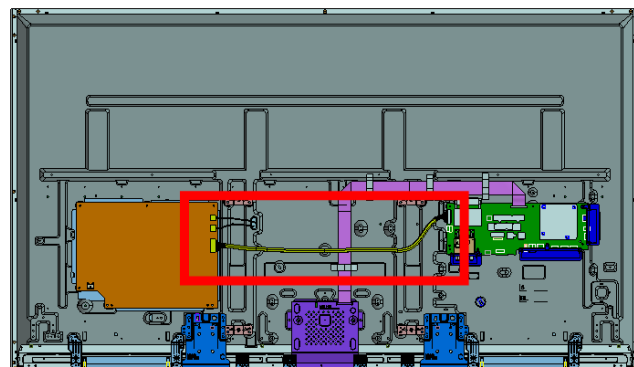

Hook Area

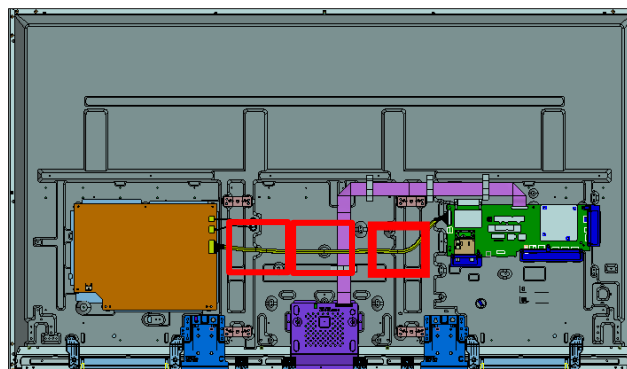

Insert tape

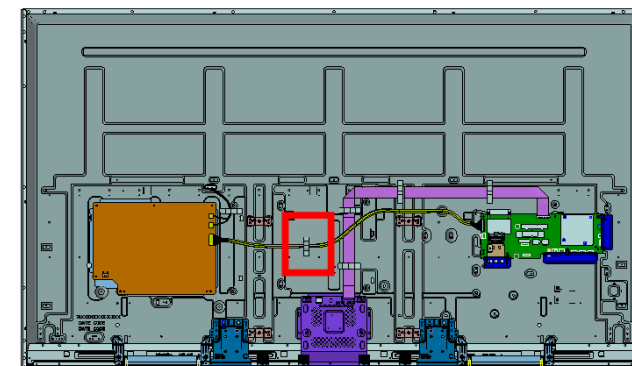

Insert Connector at GL1B/C Board

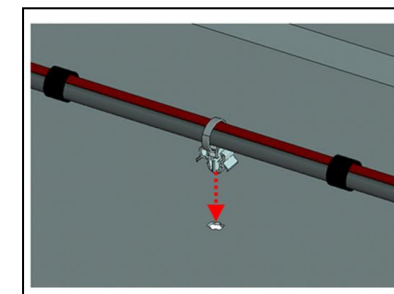
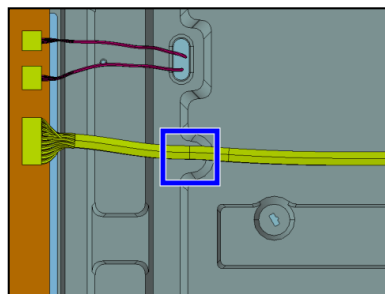
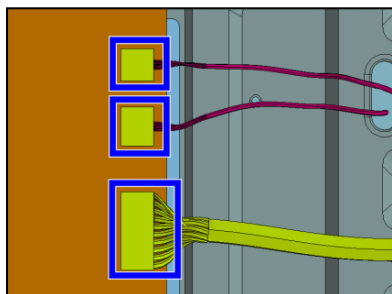

Insert Connector at BMX Board

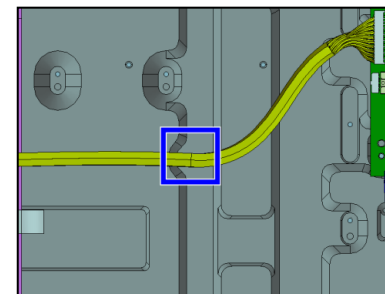
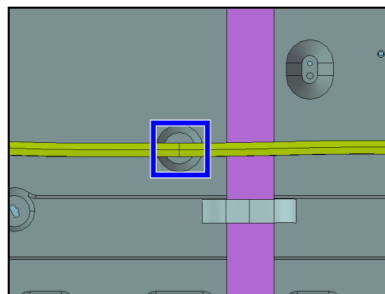
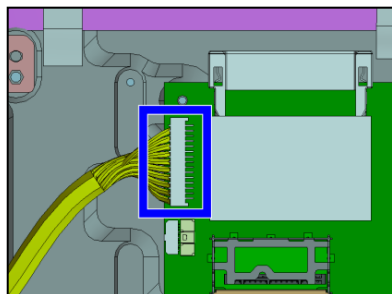

4-4-4. Wire Dressing (Switch Assy, BMX Board, Speaker Box Assy & BT Antenna)

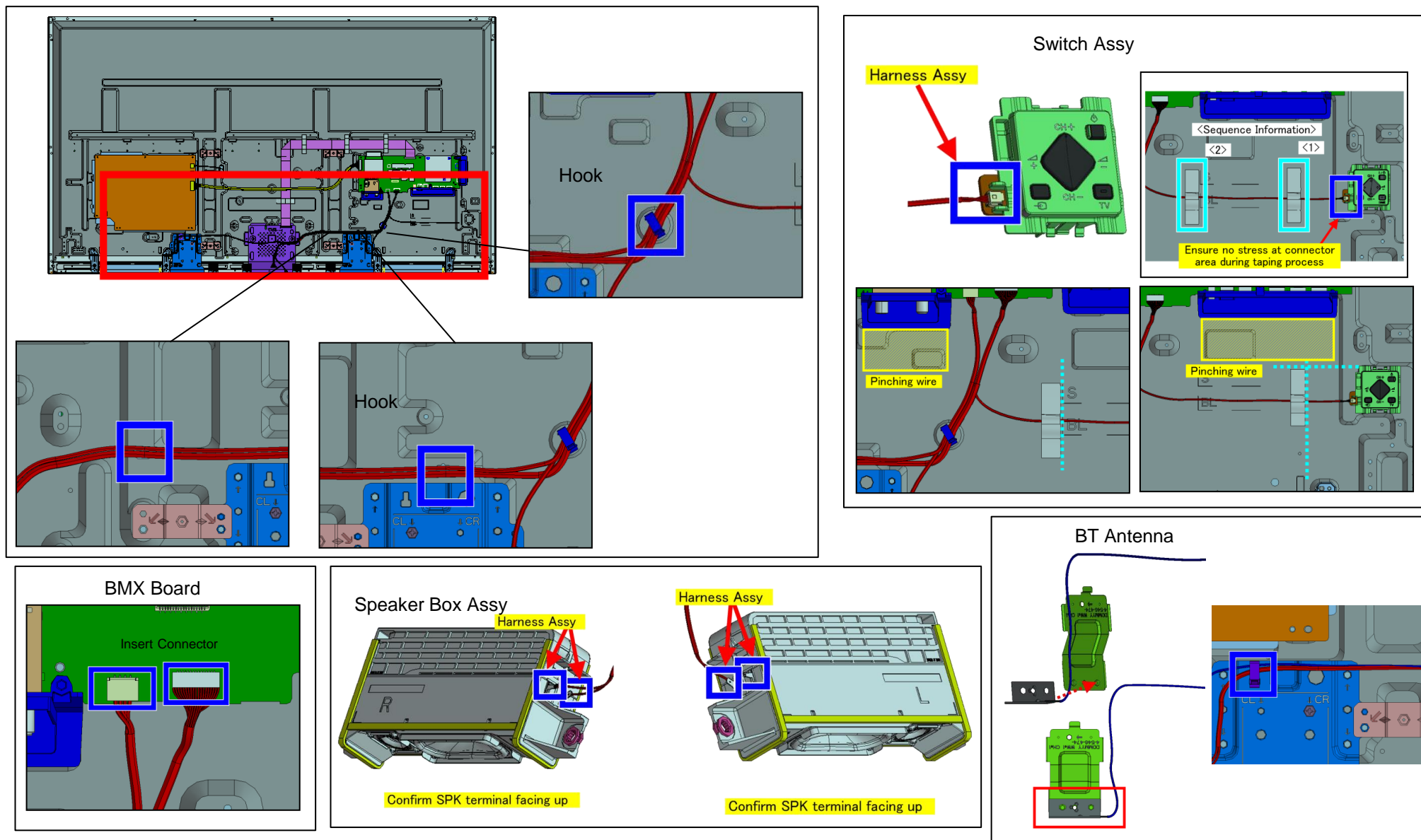

4-4-5. Wire Dressing (Smart core)

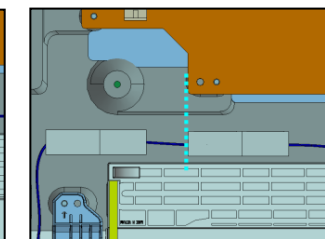
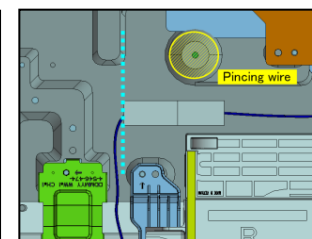
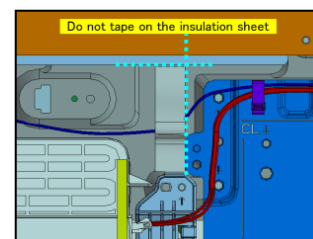
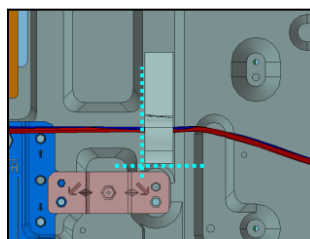
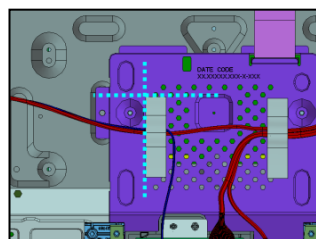
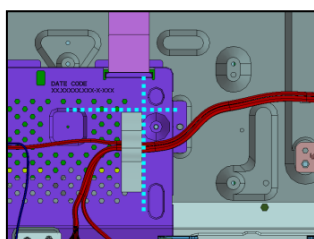
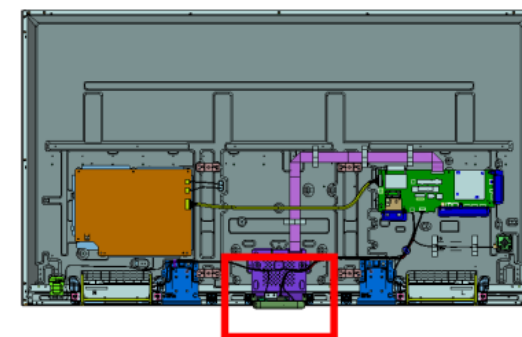
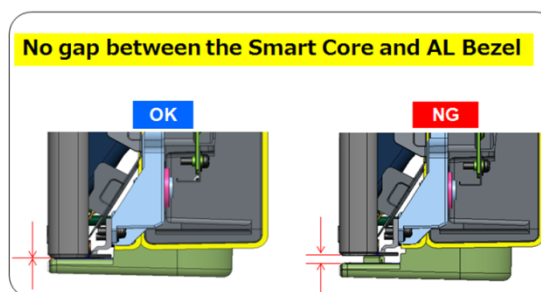
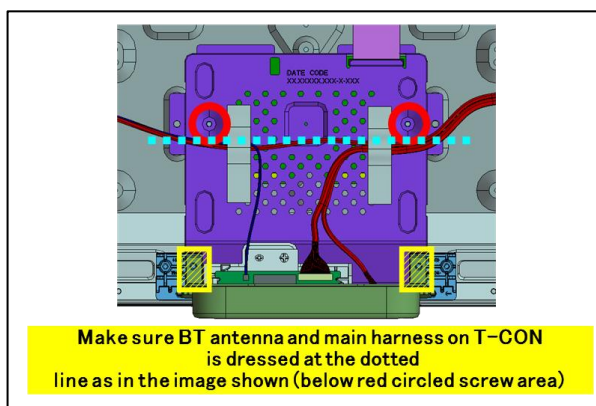
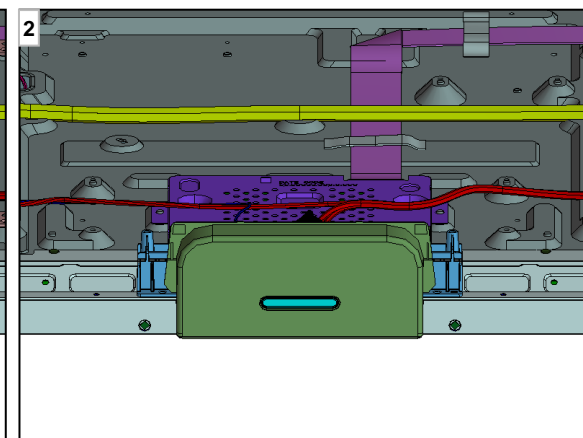
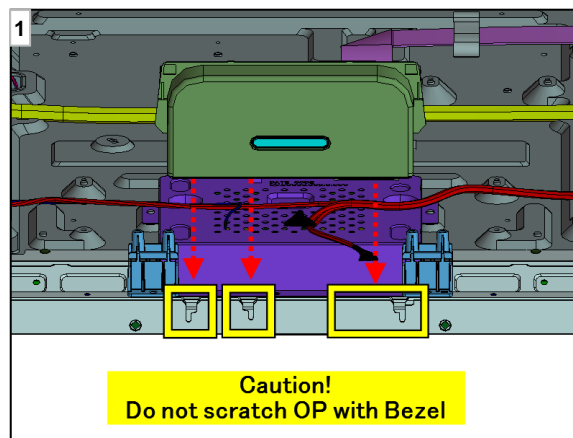
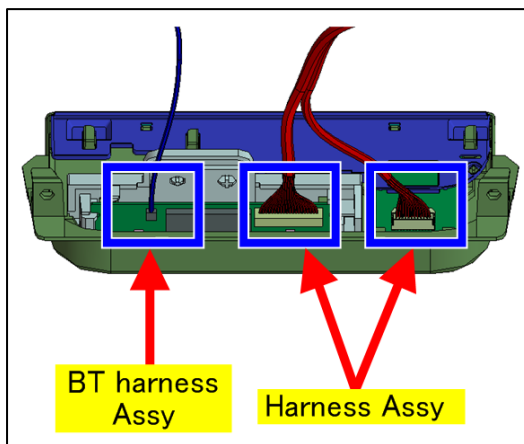

4-4-6. Wire Dressing (Harness Caution Point (Pinching Wire area))

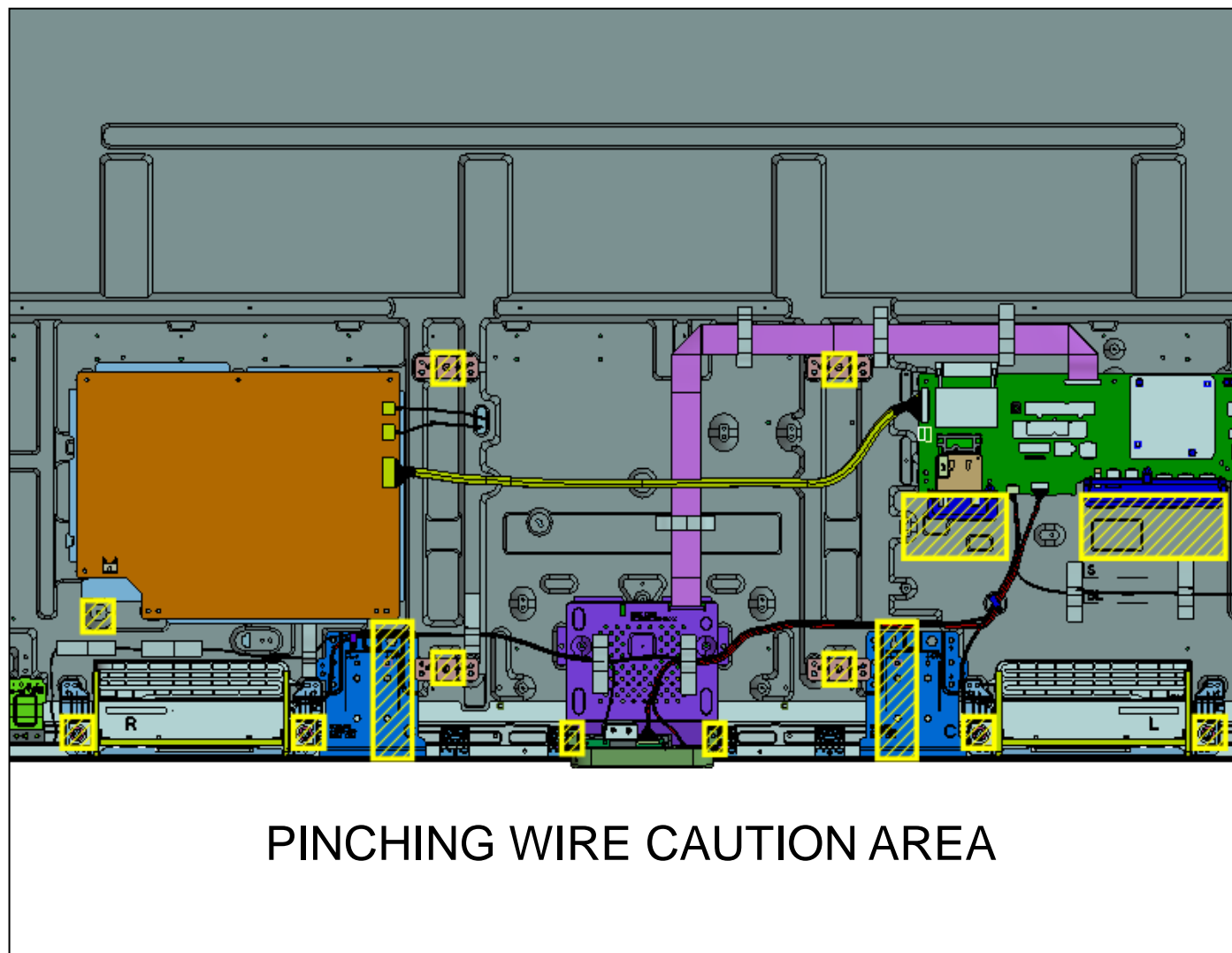

Please take caution as the wire will be easily pinched and the yellow block area

END

APPENDIX-1

1-1. Procedure To Disassemble Under Cover (Standing position)

1-1-1. Remove AC Cover

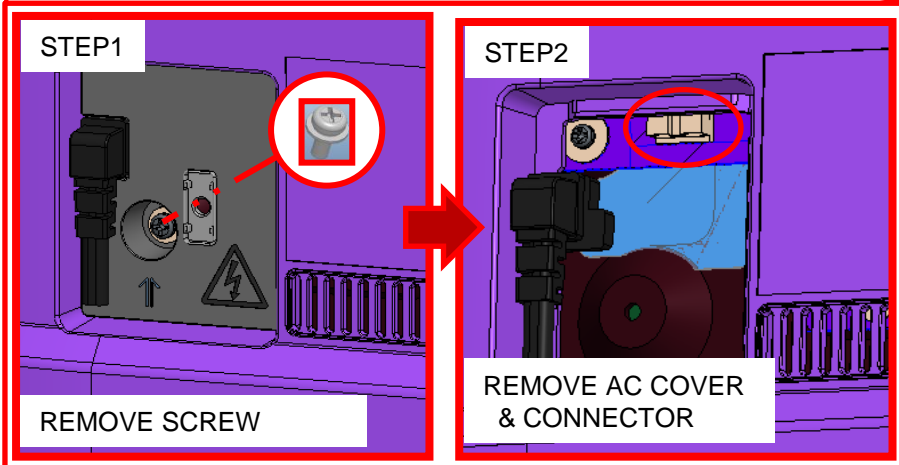
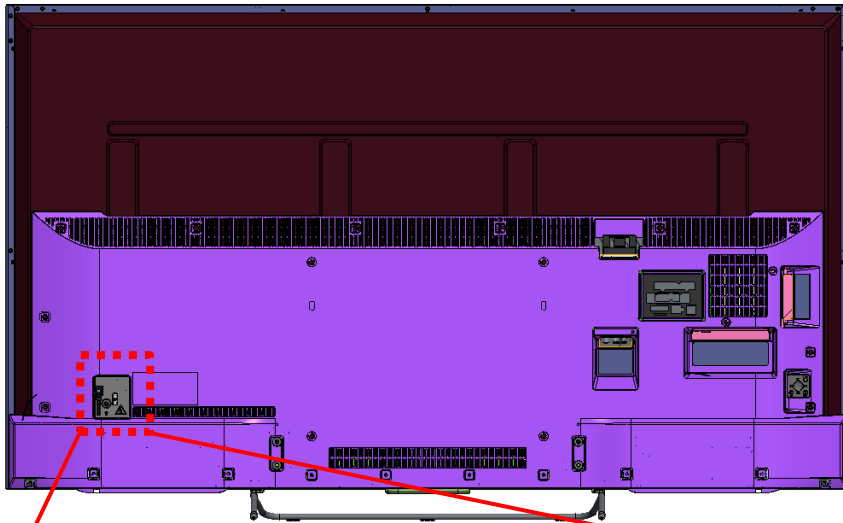

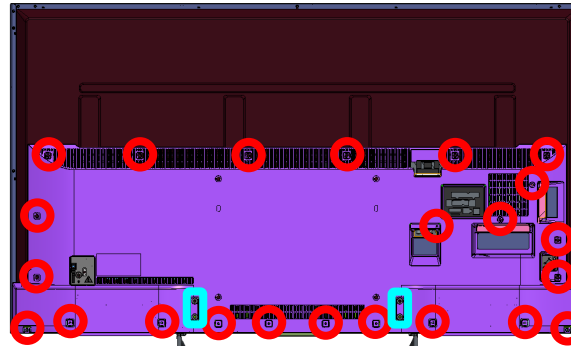

1-1-2. Disassemble screw (Without stand screw)

a. 65" model

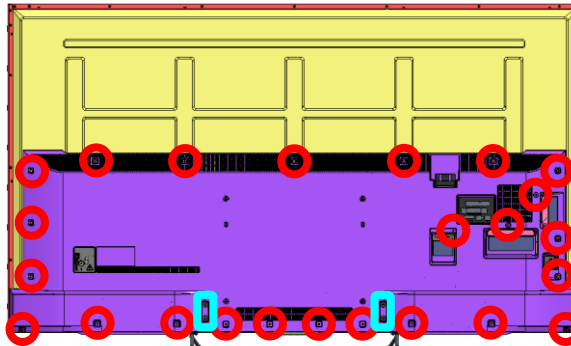

b. 75" model



-  X 23
-  X 4
(Stand screw)

1-1-3. Disassemble Under Cover

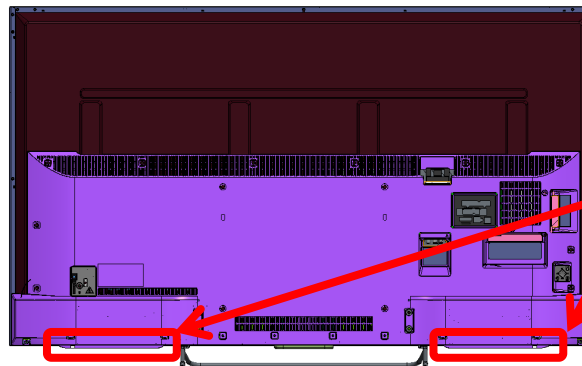

by two people

Please take out same timing both side Under Cover

Confirm all screws & positions before removing them.
Screws detail refer to Section 3

1-2. Procedure To Disassemble Smart Core

1-2-1. General



FRONT VIEW

BACK VIEW



SMART CORE PARTS

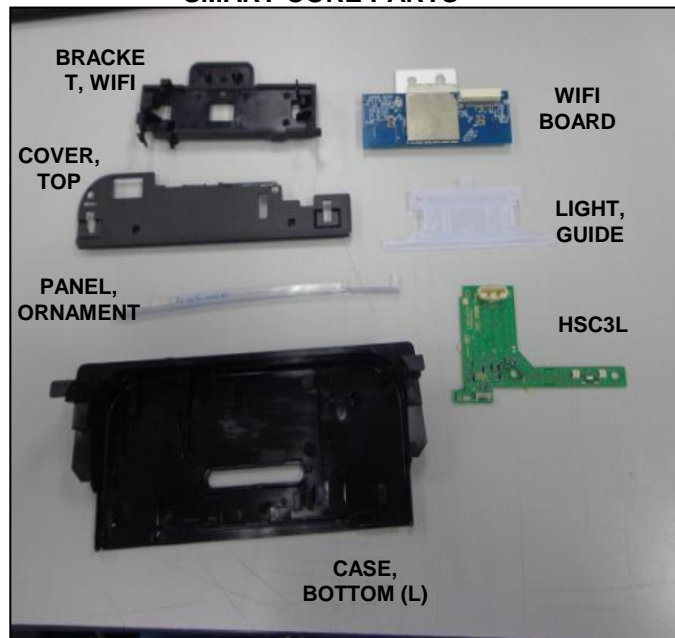

1-2-2. Smart Core Disassembly

Step 1 : Remove WIRELESS CASE by pulling the hook in the direction as shown

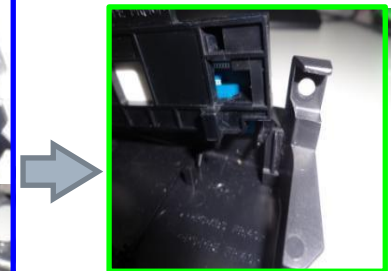
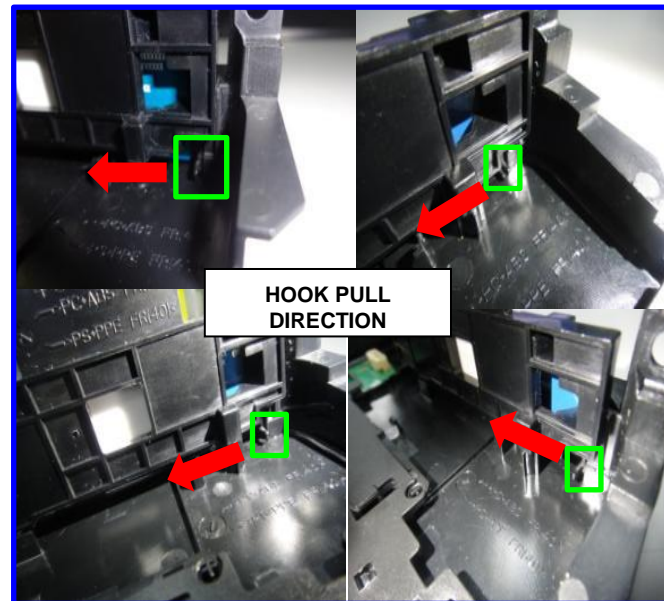

□ : Hook location

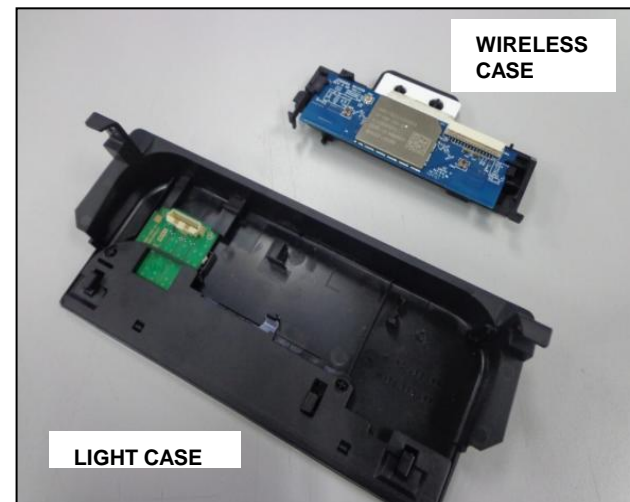

1-2-3. Wireless Case Disassembly

Step 1 : Detach from hook (1 location)

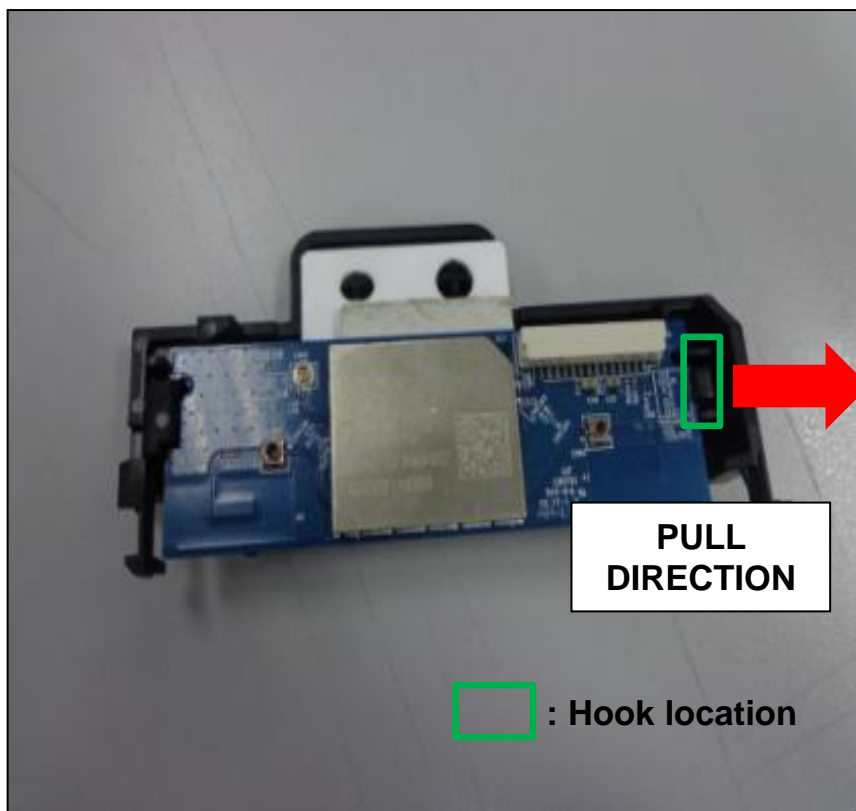

Step 2 : Remove wifi board

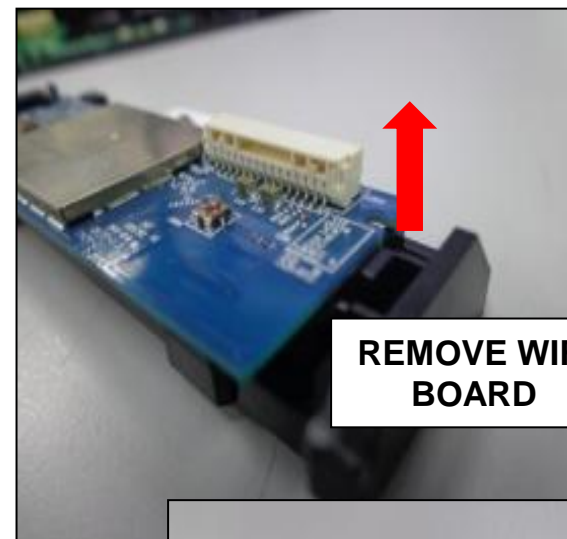

1-2-4. Light Case Disassembly

a) Disassembly of "COVER, TOP"

Take out from hook (2 location) *take out hook from "No.1" to "No.2".

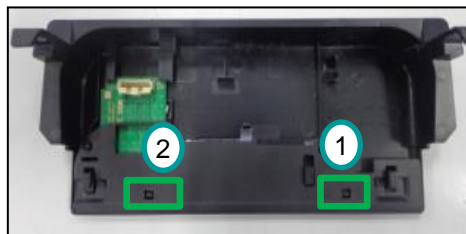

 : Hook location

Take out hook at No.1 area

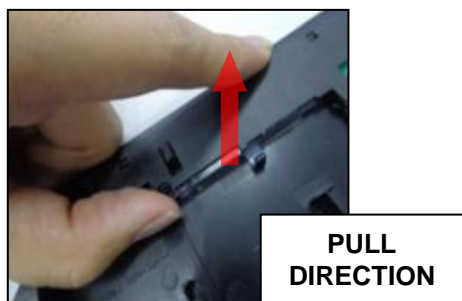

Take out hook at No.2 area

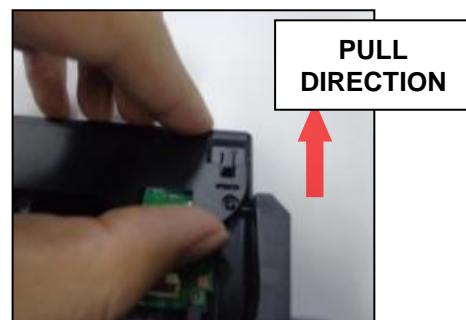

After detach No.1 hook, Detach No.2 hook.



b) Disassembly of "Panel, Ornamental"

Detach "PANEL, ORNAMENT" as shown below



Hook location

Lift the hook (Y-Direction) to release from rib.

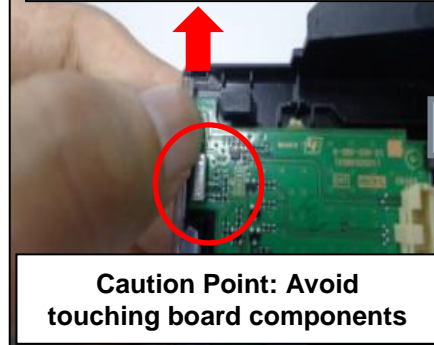

Caution Point: Avoid touching board components

Caution Point: Avoid touching board components

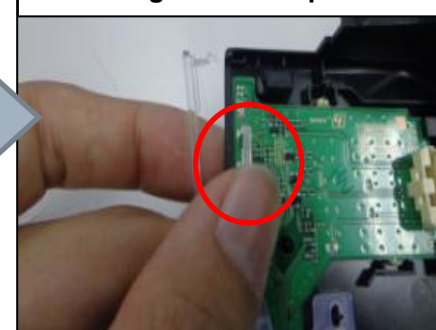

c) Disassembly of "Light, Guide"

Detach LIGHT, GUIDE from hook and push LIGHT, GUIDE from bottom simultaneously

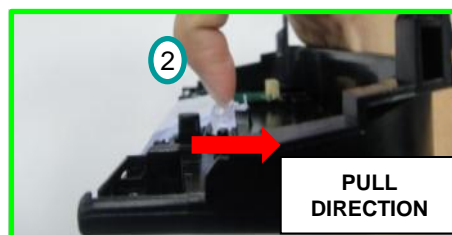
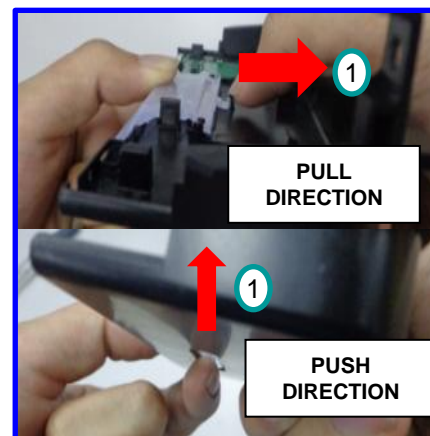
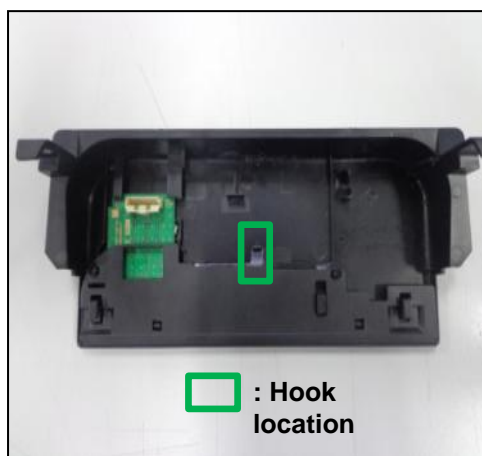

Step 3.2 : Pull the LIGHT, GUIDE inwards to remove it

Remarks:
Step 2 is important to avoid hook broken from Case, Bottom and Light, Guide.

d) Disassembly of "HSC3L Mount Board"

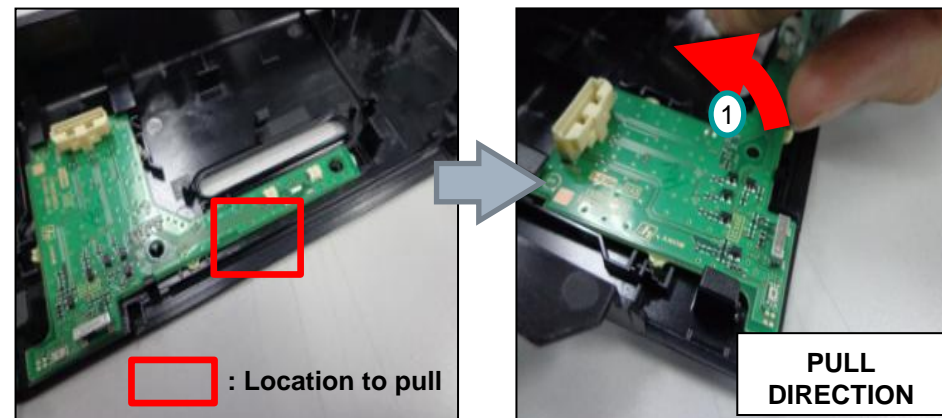

Remarks:
Do not pull on any components on HSC PWB!

