

# DVP-FX97/FX980/FX980WM

RMT-D195

## SERVICE MANUAL

Ver. 1.0 2012.01

*US Model*  
DVP-FX97/FX980/FX980WM  
*Canadian Model*  
DVP-FX980



### SPECIFICATIONS

#### System

**Laser:** Semiconductor laser  
**Signal format system:** NTSC

#### Inputs/Outputs

**A/V OUT (audio/video output):**  
Mini-jack  
**PHONES (headphones):**  
Stereo mini-jack  
**USB:** USB jack Type A (For connecting USB memory)

#### Liquid Crystal Display

**Panel size:** 9 inches wide (diagonal)  
**Driving system:** TFT active matrix  
**Resolution:** 800 x 480

#### General

**Power requirements:**  
DC 12V 0.95A (AC Adaptor)  
DC 12V 1.5A (Car battery adaptor)

**Power consumption (DVD VIDEO Playback):**  
6.5W (when used with a headphone)

#### Dimensions (approx.):

236 × 44 × 170 mm (9 3/8 × 1 3/4 × 6 3/4 inches) (width/height/depth) incl. projecting parts

**Mass (approx.):** 955 g (2.11 lbs)

**Operating temperature:** 5°C to 35°C (41°F to 95°F)

**Operating humidity:** 25% to 80%

**AC Adaptor:** 110-240V AC, 50/60Hz

**Car Battery Adaptor:** 12V DC

#### Supplied accessories

- AC adaptor (1)
- Car battery adaptor (1)
- Audio/video adaptor (1)
- Remote commander (remote) (1)
- Size AA (R6) batteries (2)

Specifications and design are subject to change without notice.



## PORTABLE CD/DVD PLAYER

# SONY®

## SAFETY CHECK-OUT

After correcting the original service problem, perform the following safety checks before releasing the set to the customer:

1. Check the area of your repair for unsoldered or poorly-soldered connections. Check the entire board surface for solder splashes and bridges.
2. Check the interboard wiring to ensure that no wires are “pinched” or contact high-wattage resistors.
3. Look for unauthorized replacement parts, particularly transistors, that were installed during a previous repair. Point them out to the customer and recommend their replacement.
4. Look for parts which, though functioning, show obvious signs of deterioration. Point them out to the customer and recommend their replacement.
5. Check the line cord for cracks and abrasion. Recommend the replacement of any such line cord to the customer.
6. Check the B+ voltage to see it is at the values specified.
7. Check the antenna terminals, metal trim, “metallized” knobs, screws, and all other exposed metal parts for AC leakage. Check leakage as described below.

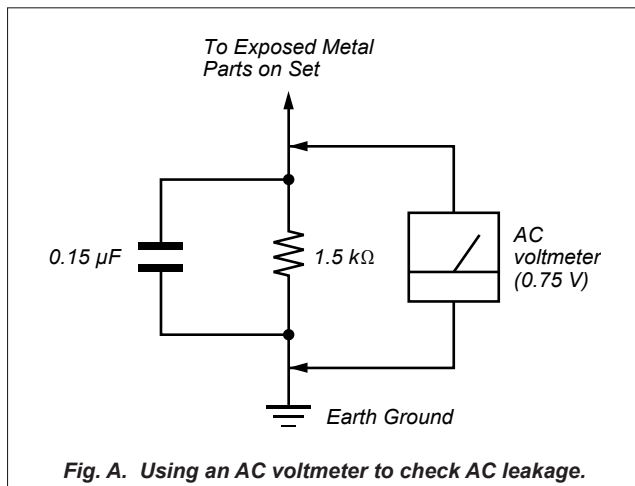

### WARNING!!

**WHEN SERVICING, DO NOT APPROACH THE LASER EXIT WITH THE EYE TOO CLOSELY. IN CASE IT IS NECESSARY TO CONFIRM LASER BEAM EMISSION, BE SURE TO OBSERVE FROM A DISTANCE OF MORE THAN 25 cm FROM THE SURFACE OF THE OBJECTIVE LENS ON THE OPTICAL PICK-UP BLOCK.**

### SAFETY-RELATED COMPONENT WARNING!!

COMPONENTS IDENTIFIED BY MARK  $\triangle$  OR DOTTED LINE WITH MARK  $\triangle$  ON THE SCHEMATIC DIAGRAMS AND IN THE PARTS LIST ARE CRITICAL TO SAFE OPERATION. REPLACE THESE COMPONENTS WITH SONY PARTS WHOSE PART NUMBERS APPEAR AS SHOWN IN THIS MANUAL OR IN SUPPLEMENTS PUBLISHED BY SONY.

### ATTENTION AU COMPOSANT AYANT RAPPORT À LA SÉCURITÉ!

LES COMPOSANTS IDENTIFIÉS PAR UNE MARQUE  $\triangle$  SUR LES DIAGRAMMES SCHÉMATIQUES ET LA LISTE DES PIÈCES SONT CRITIQUES POUR LA SÉCURITÉ DE FONCTIONNEMENT. NE REMPLACER CES COMPOSANTS QUE PAR DES PIÈCES SONY DONT LES NUMÉROS SONT DONNÉS DANS CE MANUEL OU DANS LES SUPPLÉMENTS PUBLIÉS PAR SONY.

### LEAKAGE TEST

The AC leakage from any exposed metal part to earth ground and from all exposed metal parts to any exposed metal part having a return to chassis, must not exceed 0.5 mA (500 microamperes). Leakage current can be measured by any one of three methods.

1. A commercial leakage tester, such as the Simpson 229 or RCA WT-540A. Follow the manufacturers' instructions to use these instruments.
2. A battery-operated AC milliammeter. The Data Precision 245 digital multimeter is suitable for this job.
3. Measuring the voltage drop across a resistor by means of a VOM or battery-operated AC voltmeter. The “limit” indication is 0.75V, so analog meters must have an accurate low-voltage scale. The Simpson 250 and Sanwa SH-63Trd are examples of a passive VOM that is suitable. Nearly all battery operated digital multimeters that have a 2V AC range are suitable. (See Fig. A)

### CAUTION:

The use of optical instrument with this product will increase eye hazard.

### Unleaded solder

Boards requiring use of unleaded solder are printed with the lead-free mark (LF) indicating the solder contains no lead. (Caution: Some printed circuit boards may not come printed with the lead free mark due to their particular size.)



### : LEAD FREE MARK

Unleaded solder has the following characteristics.

- Unleaded solder melts at a temperature about 40°C higher than ordinary solder.  
Ordinary soldering irons can be used but the iron tip has to be applied to the solder joint for a slightly longer time.  
Soldering irons using a temperature regulator should be set to about 350°C.  
Caution: The printed pattern (copper foil) may peel away if the heated tip is applied for too long, so be careful!
- Strong viscosity  
Unleaded solder is more viscous (sticky, less prone to flow) than ordinary solder so use caution not to let solder bridges occur such as on IC pins, etc.

## TABLE OF CONTENTS

<u>Section</u>	<u>Title</u>	<u>Page</u>	<u>Section</u>	<u>Title</u>	<u>Page</u>
1.	DISASSEMBLY		5.	WAVEFORMS AND CIRCUIT VOLTAGE	
1-1.	Disassembly Flow .....	1-1	5-1.	Waveforms .....	5-1
1-2.	Bottom Block .....	1-1	5-2.	Circuit Voltage Chart .....	5-3
1-3.	Traverse unit/ Main Board/ Battery.....	1-2	6.	IC PIN FUNCTION DESCRIPTION	
1-4.	Upper Block.....	1-2	6-1.	Servo & DSP & MPEG IC (MAIN BOARD) .....	6-1
1-5.	LCD Screen/ LCD Board .....	1-3	7.	ELECTRICAL ADJUSTMENT	
2.	BLOCK DIAGRAM		7-1.	Standard Video Level.....	7-1
2-1.	Overall Block Diagram.....	2-1	8.	TROUBLESHOOTING	
3.	SCHEMATIC DIAGRAMS		8-1.	Electrical Trouble Shooting Guide.....	8-1
3-1.	Frame Schematic Diagram (1/3) .....	3-1	9.	REPAIR PARTS LIST	
3-2.	Frame Schematic Diagram (2/3) .....	3-2	9-1.	EXPLODED VIEWS .....	9-1
3-3.	Frame Schematic Diagram (3/3) .....	3-3	9-1-1.	Bottom Block .....	9-1
3-4.	MAIN Board (1/5) .....	3-4	9-1-2.	Traverse unit/ Main Board/ Battery.....	9-1
3-5.	MAIN Board (2/5) .....	3-5	9-1-3.	Upper Block.....	9-2
3-6.	MAIN Board (3/5) .....	3-6	9-1-4.	LCD Screen/ LCD Board .....	9-2
3-7.	MAIN Board (4/5) .....	3-7	9-1-5.	Accessories .....	9-3
3-8.	MAIN Board (5/5) .....	3-8			
3-9.	LCD Board .....	3-9			
3-10.	TOUCH Board .....	3-10			
4.	PRINTED WIRING BOARD				
4-1.	MAIN Board.....	4-1			
4-2.	LCD Board.....	4-2			
4-3.	TOUCH Board .....	4-3			

## SECTION 1 DISASSEMBLY

•This set can be disassembled in the order shown below.

### 1-1. DISASSEMBLY FLOW

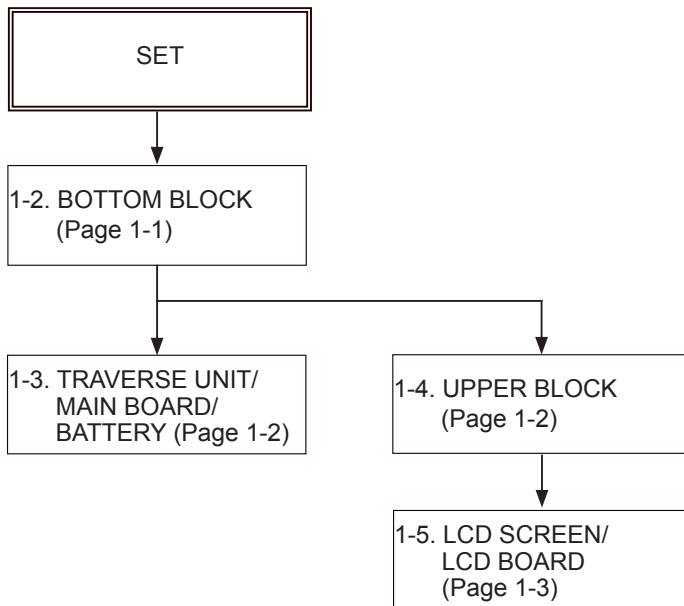

**NOTE:** Follow the disassembly procedure in the numerical order given.

### 1-2. BOTTOM BLOCK

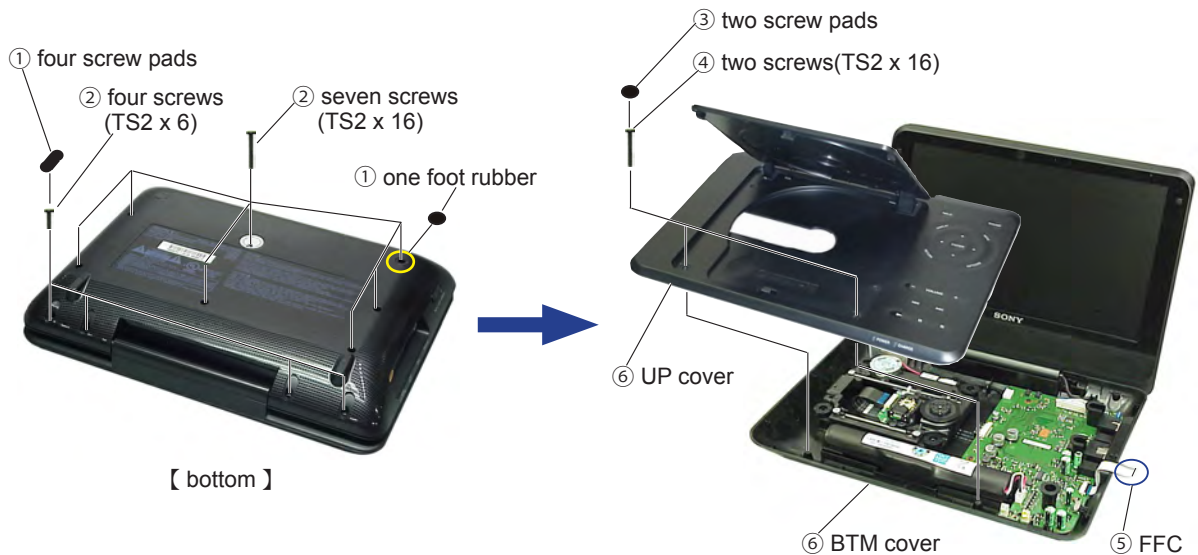

1-3. TRAVERSE UNIT/ MAIN BOARD/ BATTERY

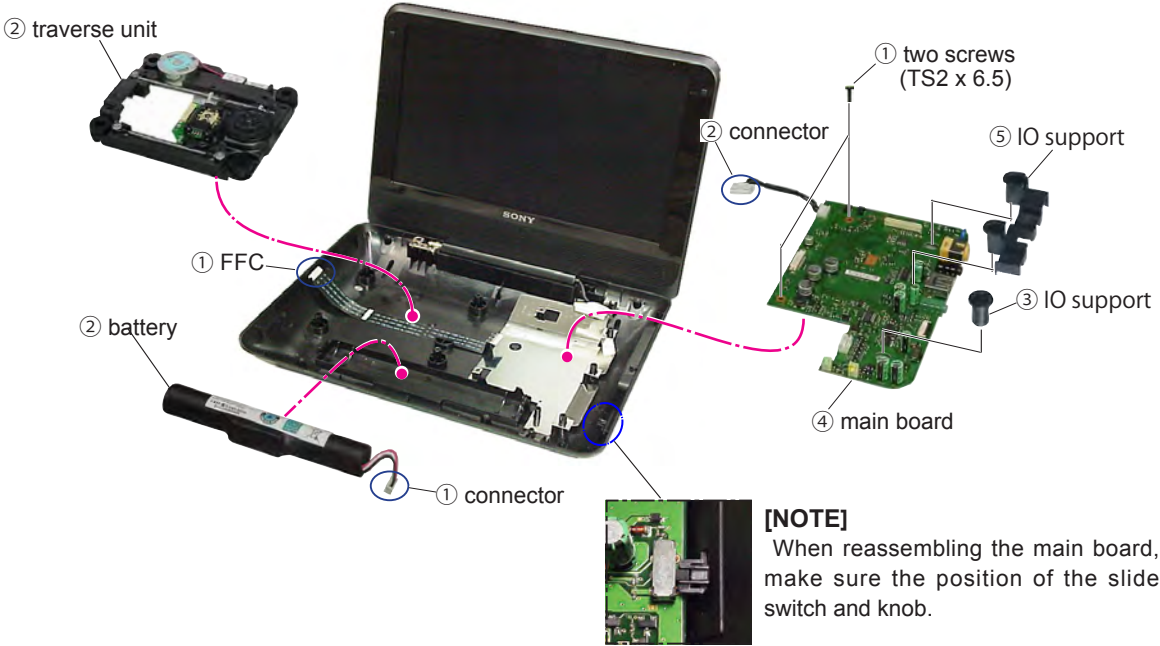

1-4. UPPER BLOCK (1/2)

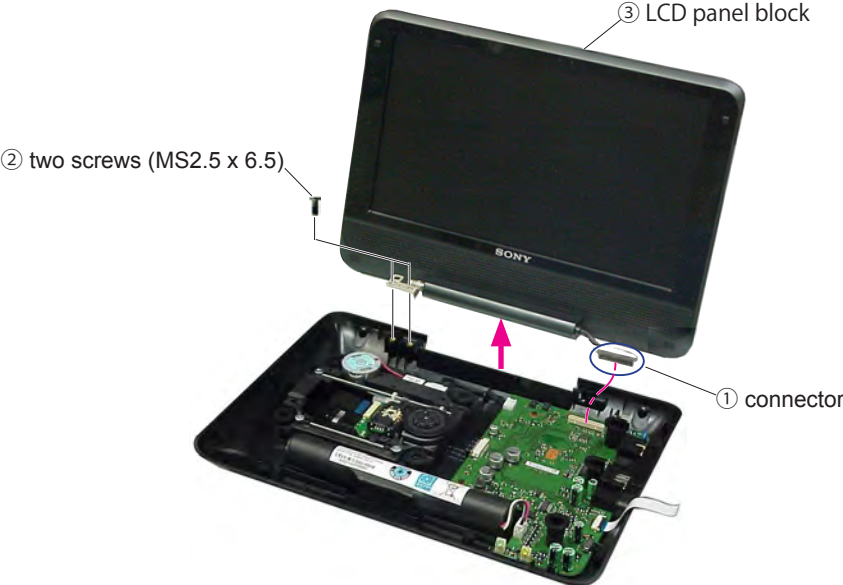

### 1-4. UPPER BLOCK (2/2)

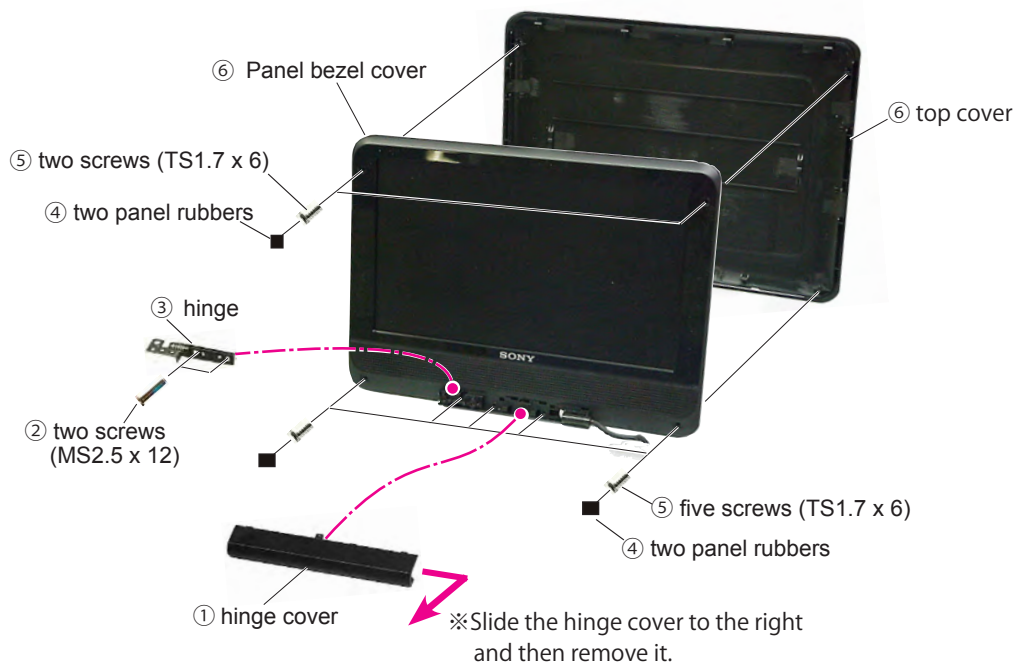

### 1-5. LCD SCREEN/ LCD BOARD

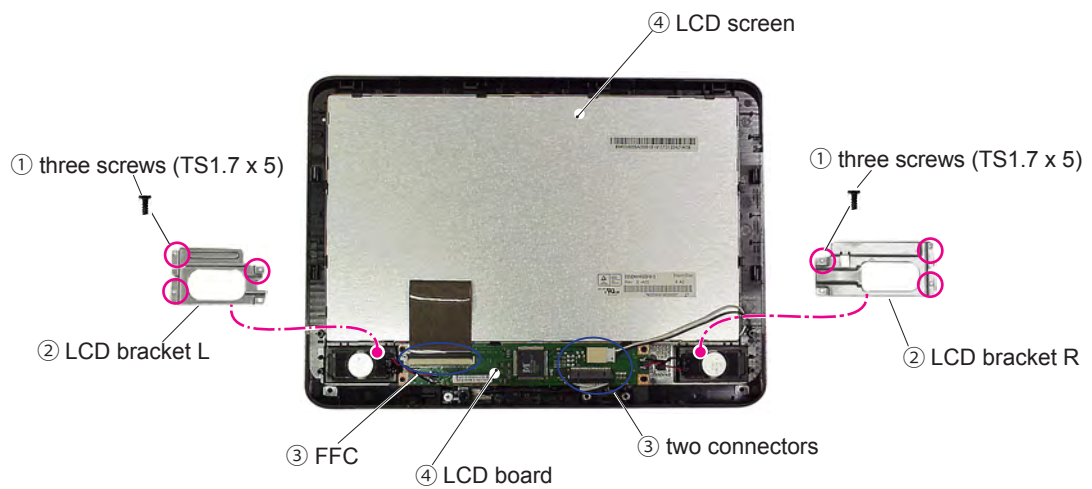

SECTION 2  
BLOCK DIAGRAM

2-1. OVERALL BLOCK DIAGRAM

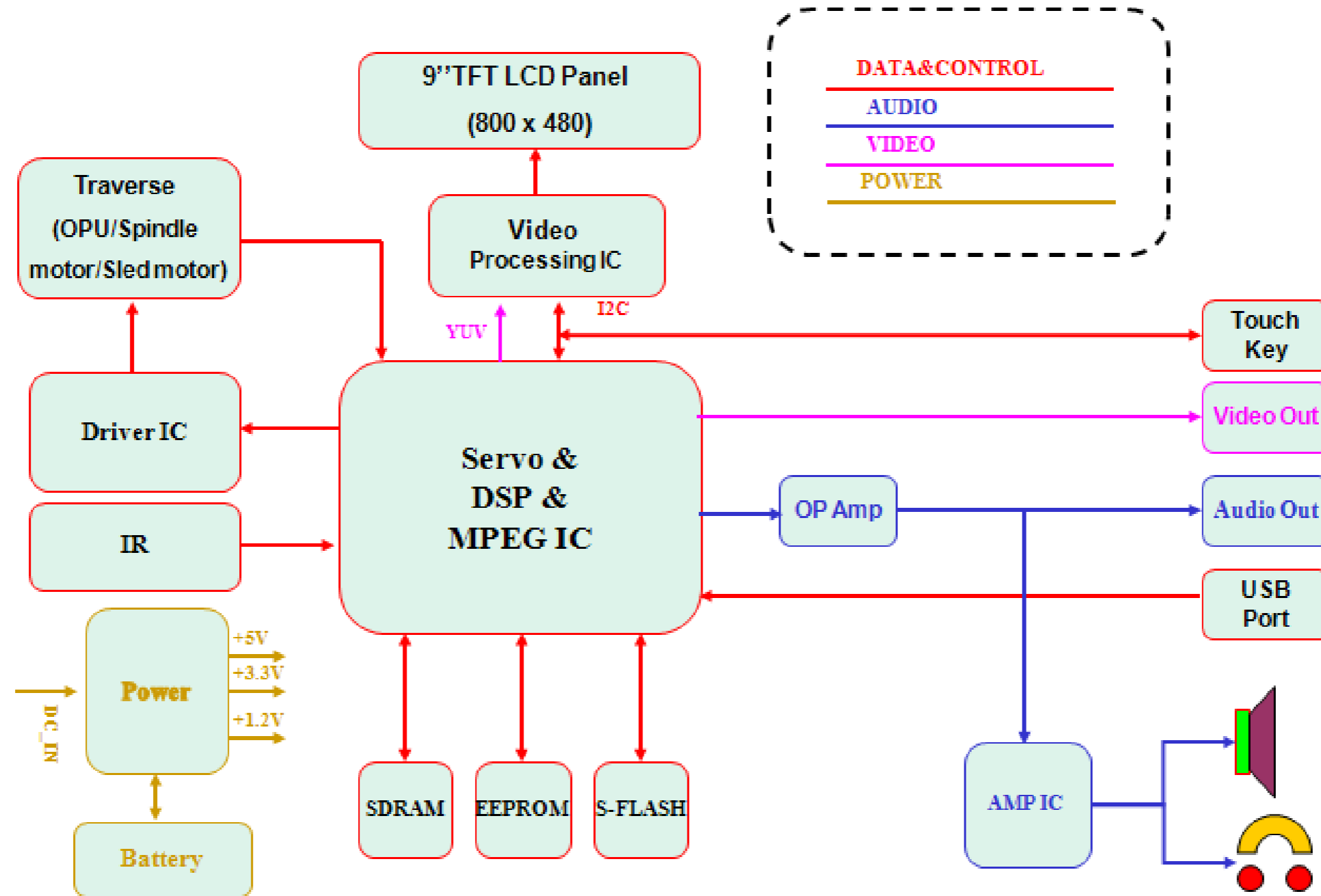

SECTION 3  
SCHEMATIC DIAGRAMS

3-1. FRAME SCHEMATIC DIAGRAM (1/3)

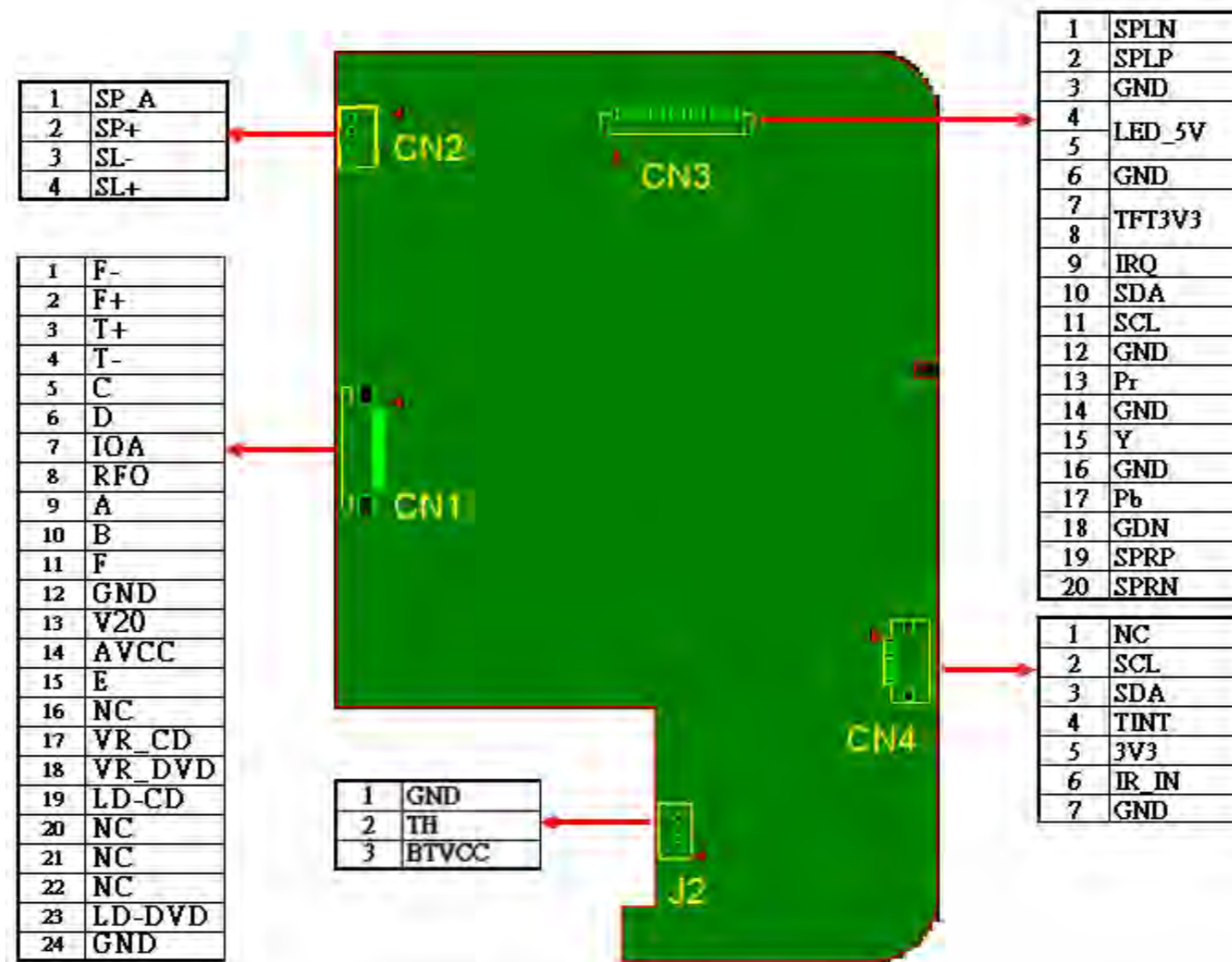

3-2. FRAME SCHEMATIC DIAGRAM (2/3)



1	NC	31	HSD
2	GND	32	DE
3	VGL	33	DCLK
4	VCC	34	B7
5	VGH	35	B6
6	NC	36	B5
7	V1	37	B4
8	V2	38	B3
9	V3	39	B2
10	V4	40	B1
11	V5	41	B0
12	V6	42	G7
13	V7	43	G6
14	V8	44	G5
15	V9	45	G4
16	V10	46	G3
17	NC	47	G2
18	NC	48	G1
19	DITH	49	G0
20	VCOM	50	R7
21	AVDD	51	R6
22	AGND	52	R5
23	GND	53	R4
24	UPDN	54	R3
25	VCC	55	R2
26	SHLR	56	R1
27	STBYB	57	R0
28	RSTB	58	VCC
29	MODE	59	AVDD
30	VSD	60	AGND

1	SPR2
2	SPR1
3	GND
4	Pb
5	GND
6	Y
7	GND
8	Pr
9	GND
10	SCL
11	SDA
12	IRQ
13	3V3
14	GND
15	GND
16	LED5V
17	GND
18	GND
19	SPL1
20	SPL2

## 3-3. FRAME SCHEMATIC DIAGRAM (3/3)

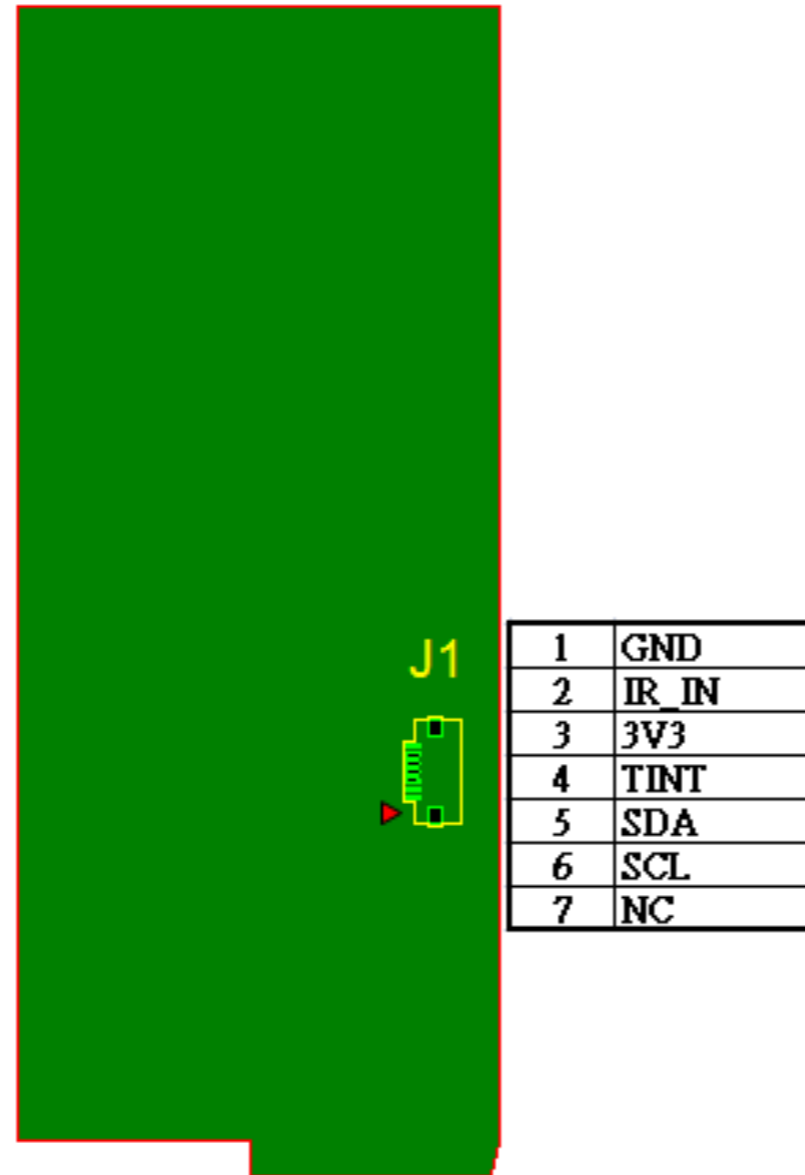

# MAIN BOARD(1/5)

A  
B  
C  
D  
E  
F  
G  
H  
I  
J

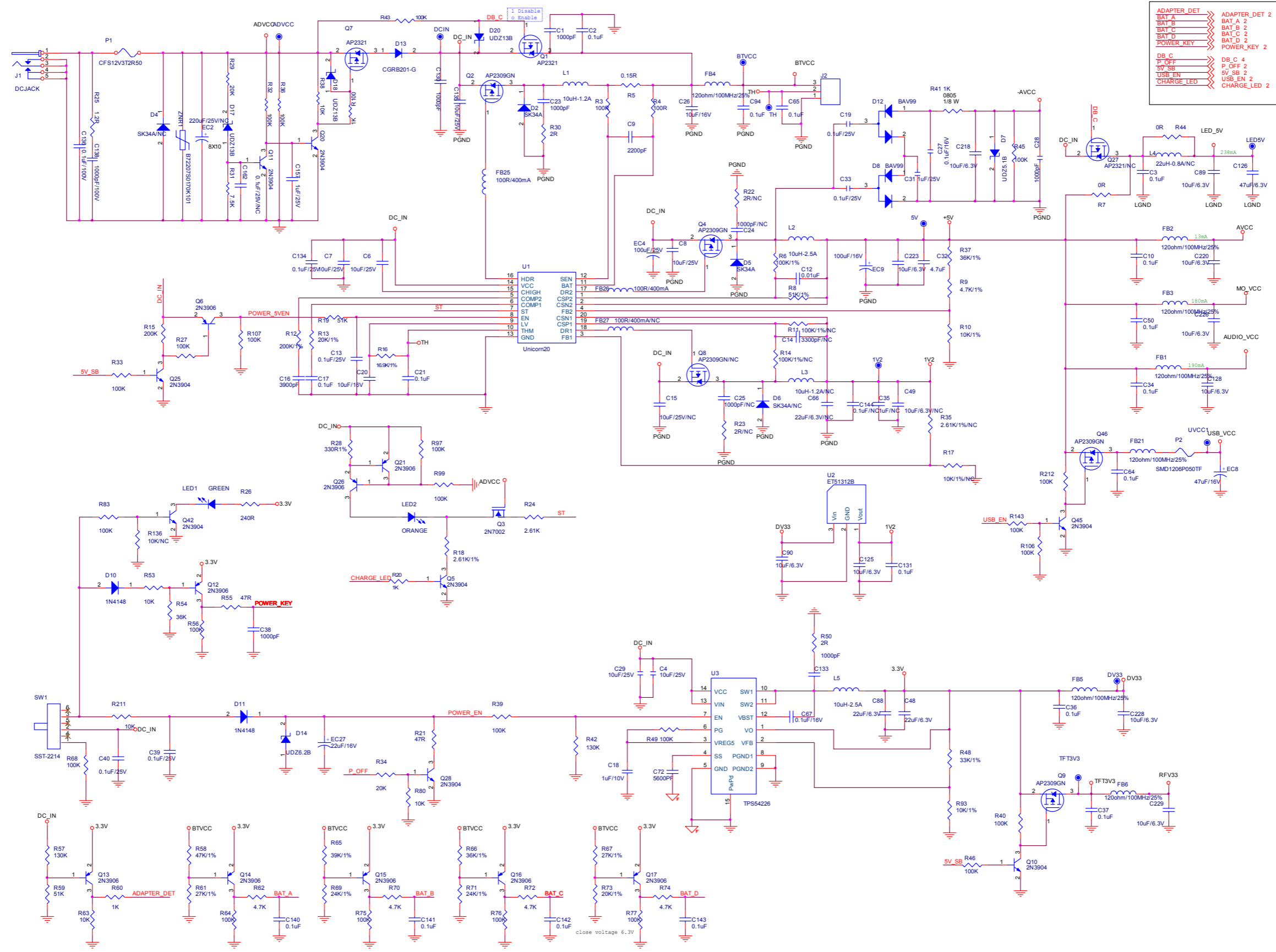

ADAPTER_DET	ADAPTER_DET 2
BAT_A	BAT_A 2
BAT_B	BAT_B 2
BAT_C	BAT_C 2
BAT_D	BAT_D 2
POWER_KEY	POWER_KEY 2
DB_C	DB_C 4
P_OFF	P_OFF 2
5V_SB	5V_SB 2
USB_EN	USB_EN 2
CHARGE_LED	CHARGE_LED 2

3-5. MAIN BOARD (2/5) • See page 4-1 printed wiring board.

# MAIN BOARD(2/5)

A  
B  
C  
D  
E  
F  
G  
H  
I  
J

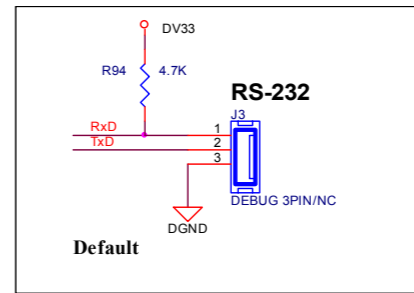
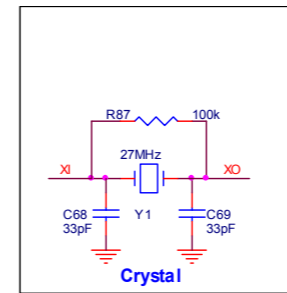
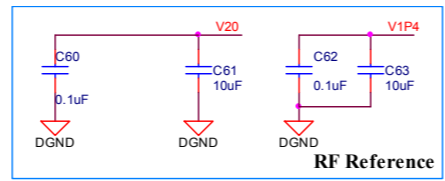
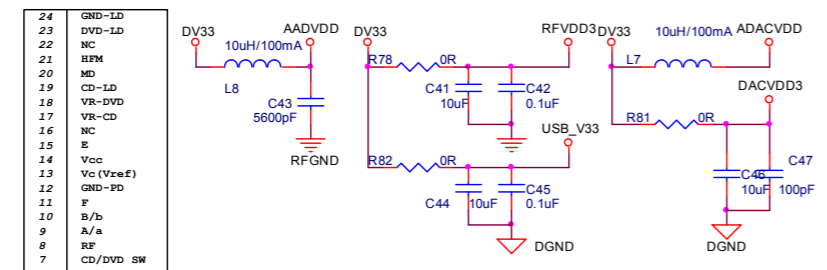

ADAPTER_DET	ADAPTER_DET 1
BAT_A	BAT_A 1
BAT_B	BAT_B 1
BAT_C	BAT_C 1
BAT_D	BAT_D 1
POWER_KEY	POWER_KEY 1
P_OFF	P_OFF 1
5V_SB	5V_SB 1
USB_EN	USB_EN 1
CHARGE_LED	CHARGE_LED 1

DCLK	DCLK 3
CAS#	CAS# 3
RAS#	RAS# 3
WE#	WE# 3
BA0	BA0 3
BA1	BA1 3
MA0..11	MA0..11 3
DQM0..11	DQM0..11 3
DQ0..15	DQ0..15 3

SF_CK	SF_CK 3
SF_CS	SF_CS 3
SF_DI	SF_DI 3
SF_DO	SF_DO 3

TFT_IRQ	TFT_IRQ 4
SCL	SCL 3,4
SDA	SDA 3,4

USBM	USBM 4
USBP	USBP 4
MTK_Pt	MTK_Pt 4
MTK_Pb	MTK_Pb 4
MTK_Y	MTK_Y 4
MTK_CVBS	MTK_CVBS 5

EAR_DE	EAR_DE 5
AUDIO_L	AUDIO_L 5
AUDIO_R	AUDIO_R 5
MUTE	MUTE 5
VOL_PWM	VOL_PWM 5

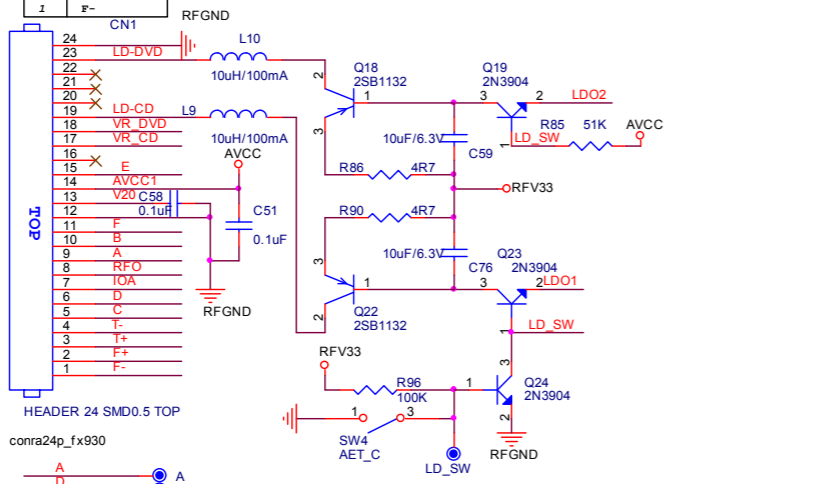

3-6. MAIN BOARD (3/5) • See page 4-1 printed wiring board.

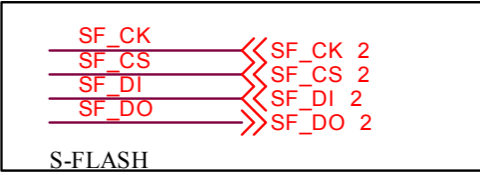
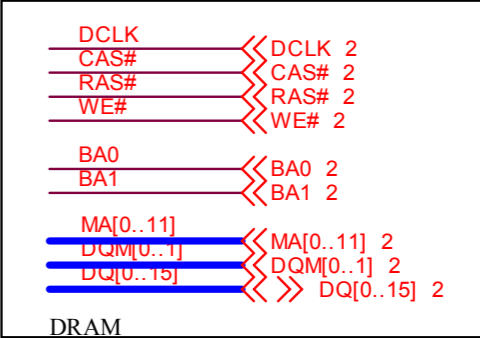
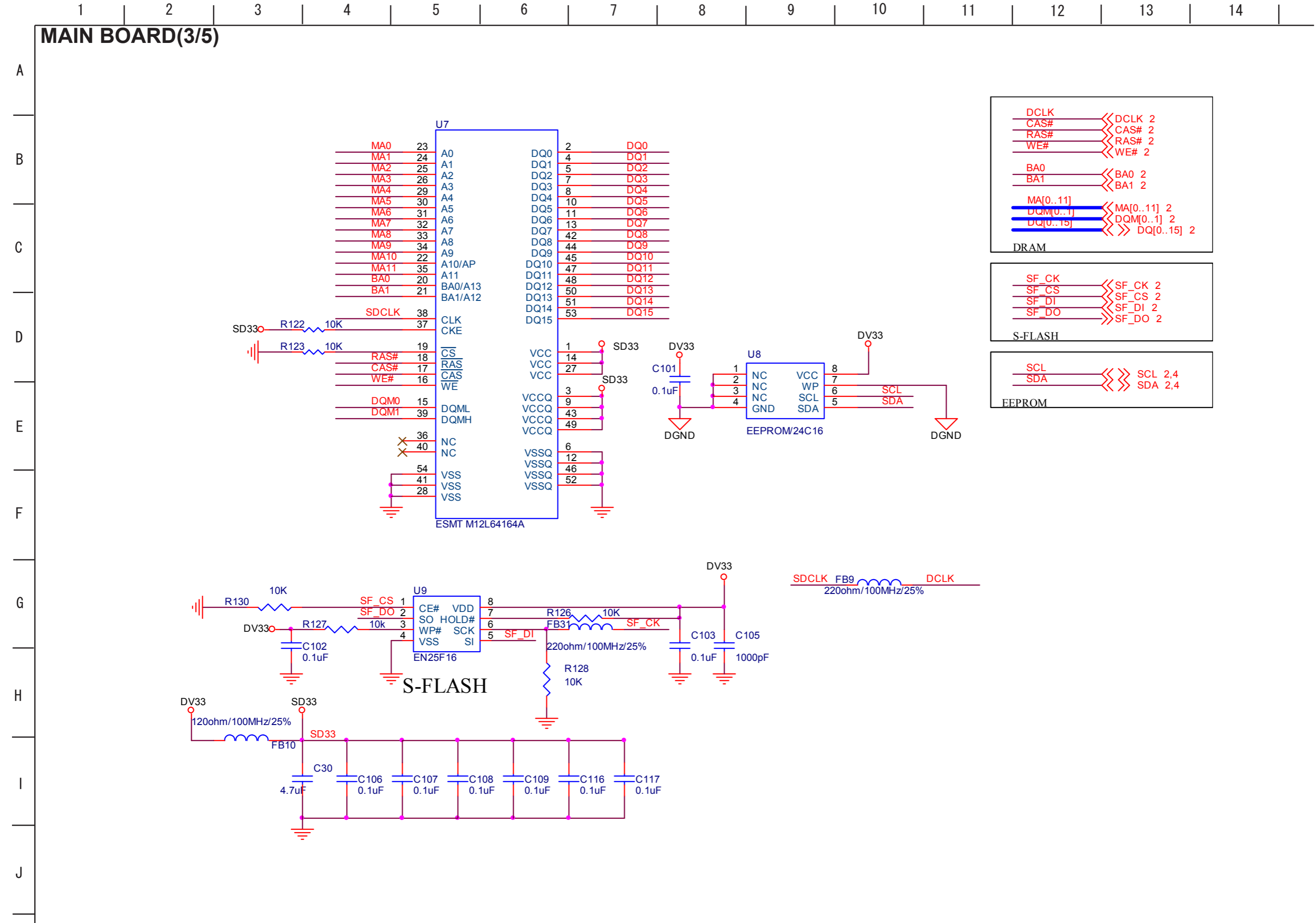

3-7. MAIN BOARD (4/5) • See page 4-1 printed wiring board.

MAIN BOARD(4/5)

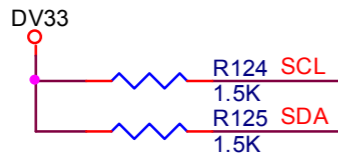
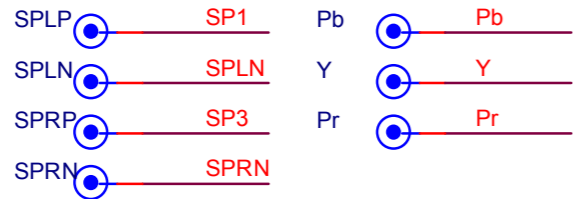
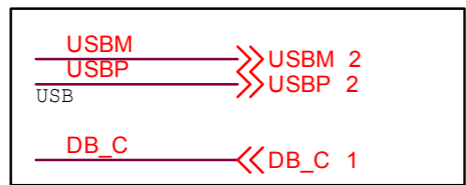
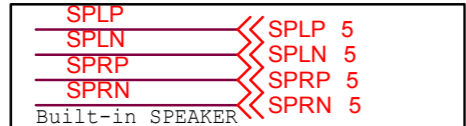
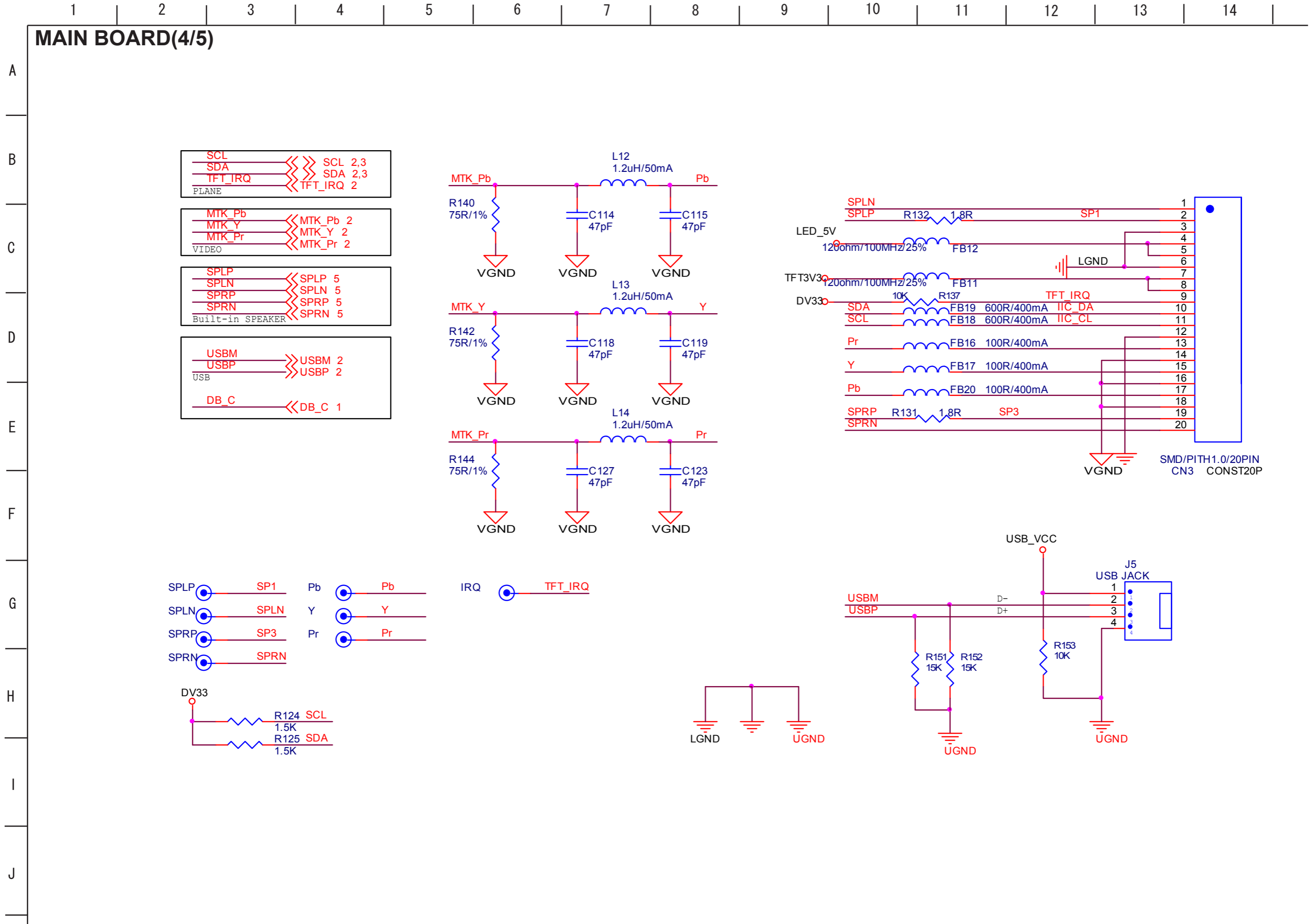

MAIN BOARD(5/5)

A  
B  
C  
D  
E  
F  
G  
H  
I  
J

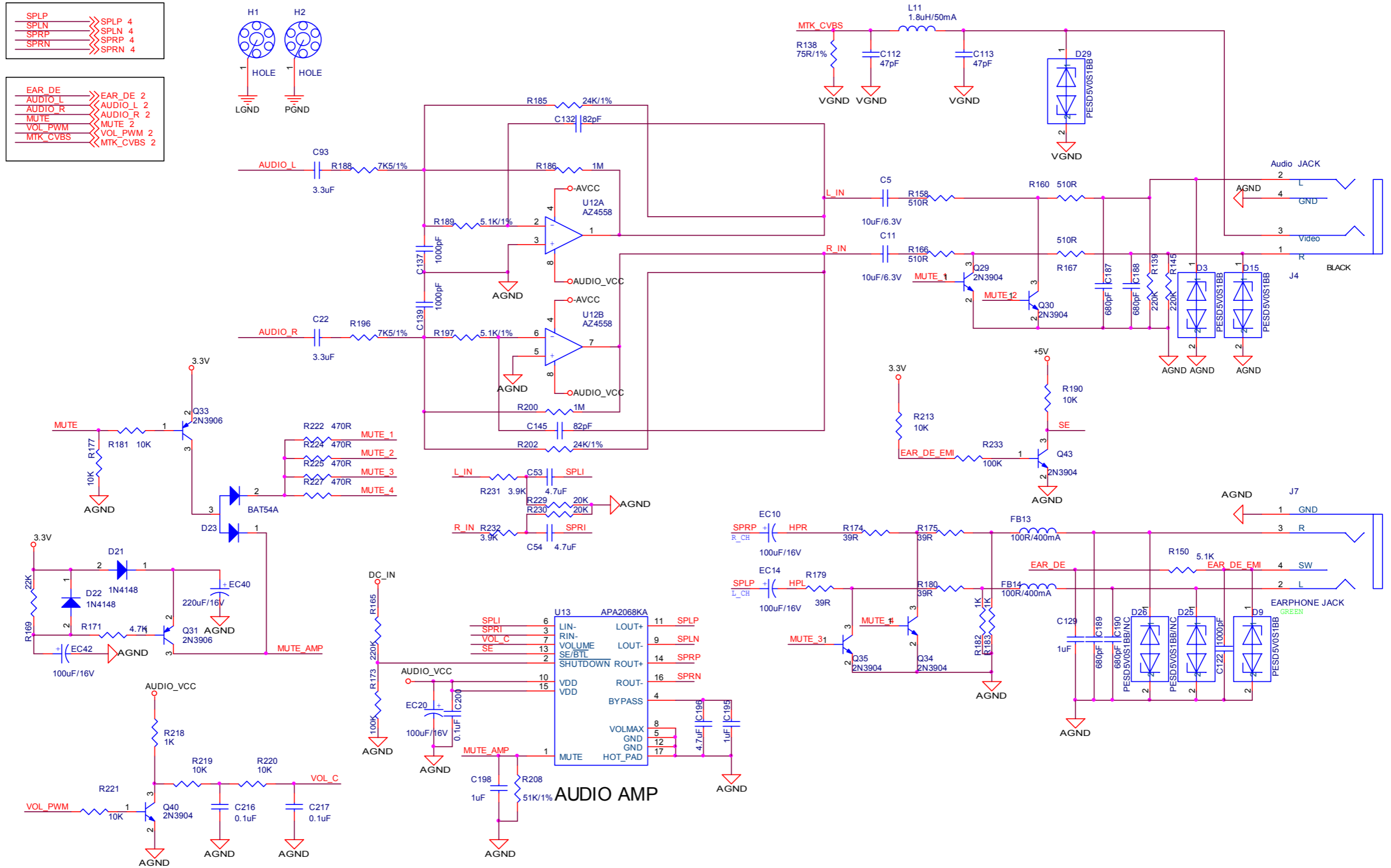
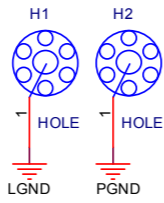
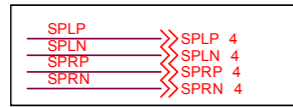

3-9. LCD BOARD • See page 4-2 printed wiring board.

LCD BOARD

A  
B  
C  
D  
E  
F  
G  
H  
I  
J

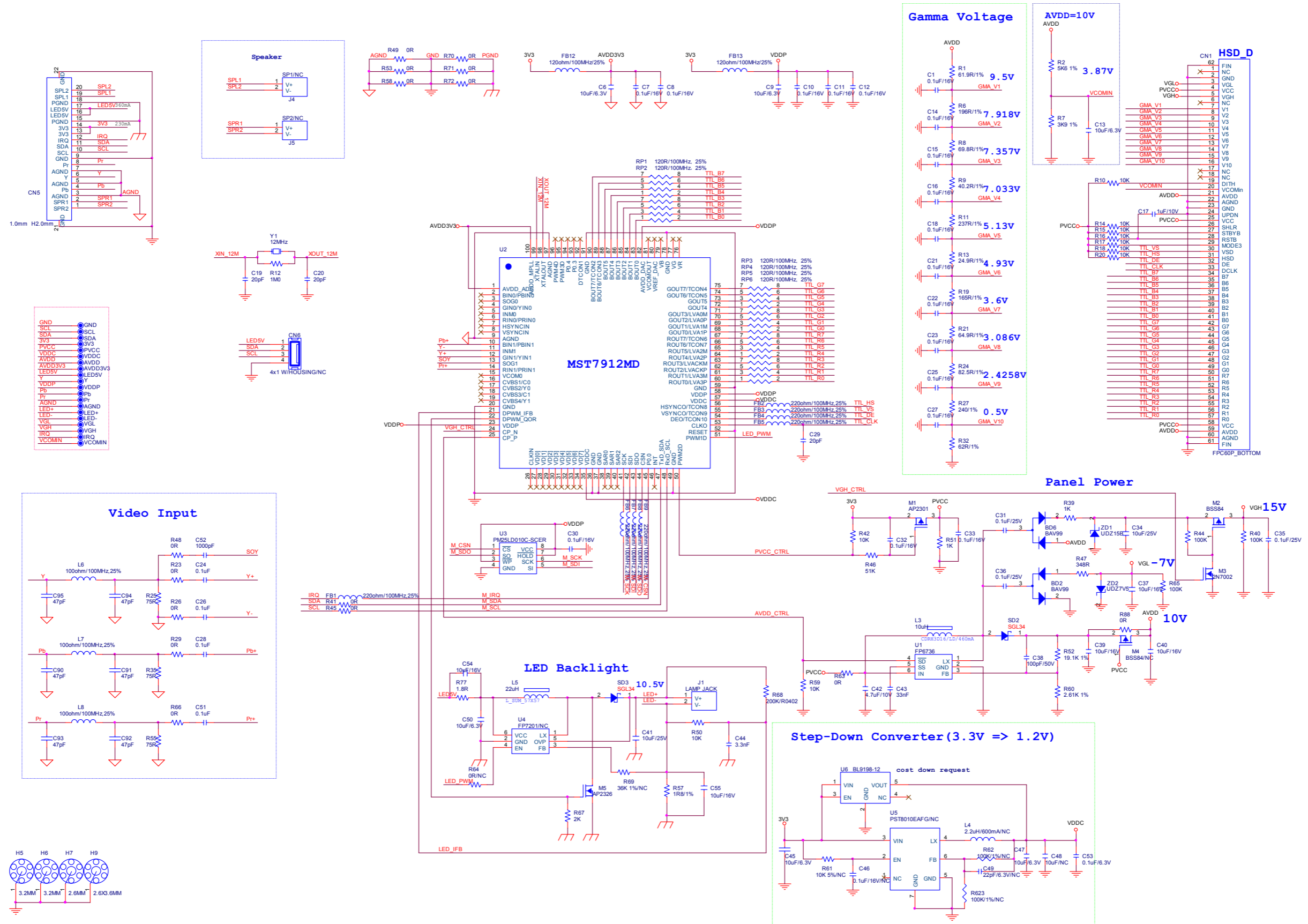

3-10. TOUCH BOARD •See page 4-3 printed wiring board.

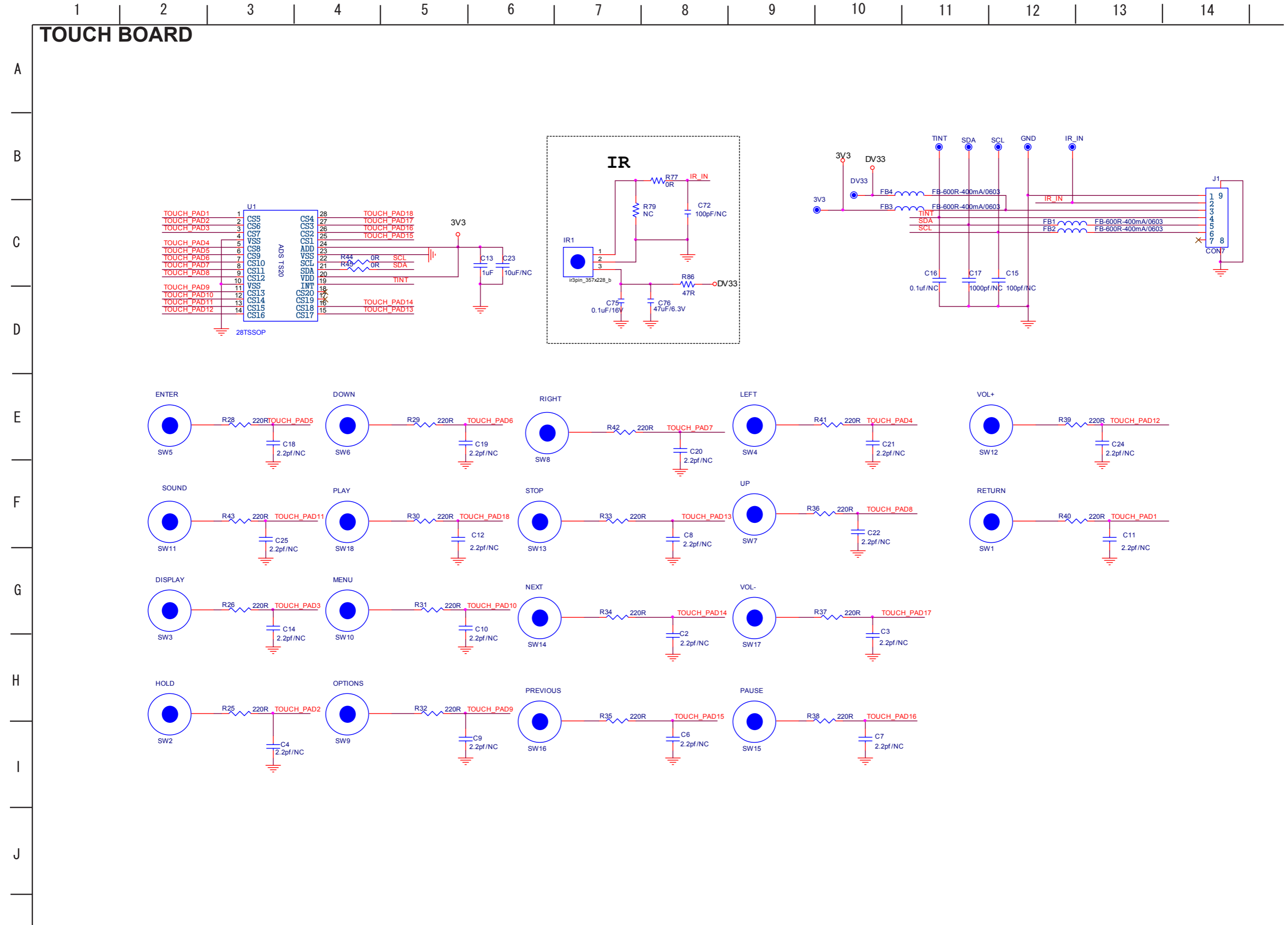

### SECTION 4 PRINTED WIRING BOARDS

#### 4-1. MAIN BOARD

 : Uses unleaded solder.

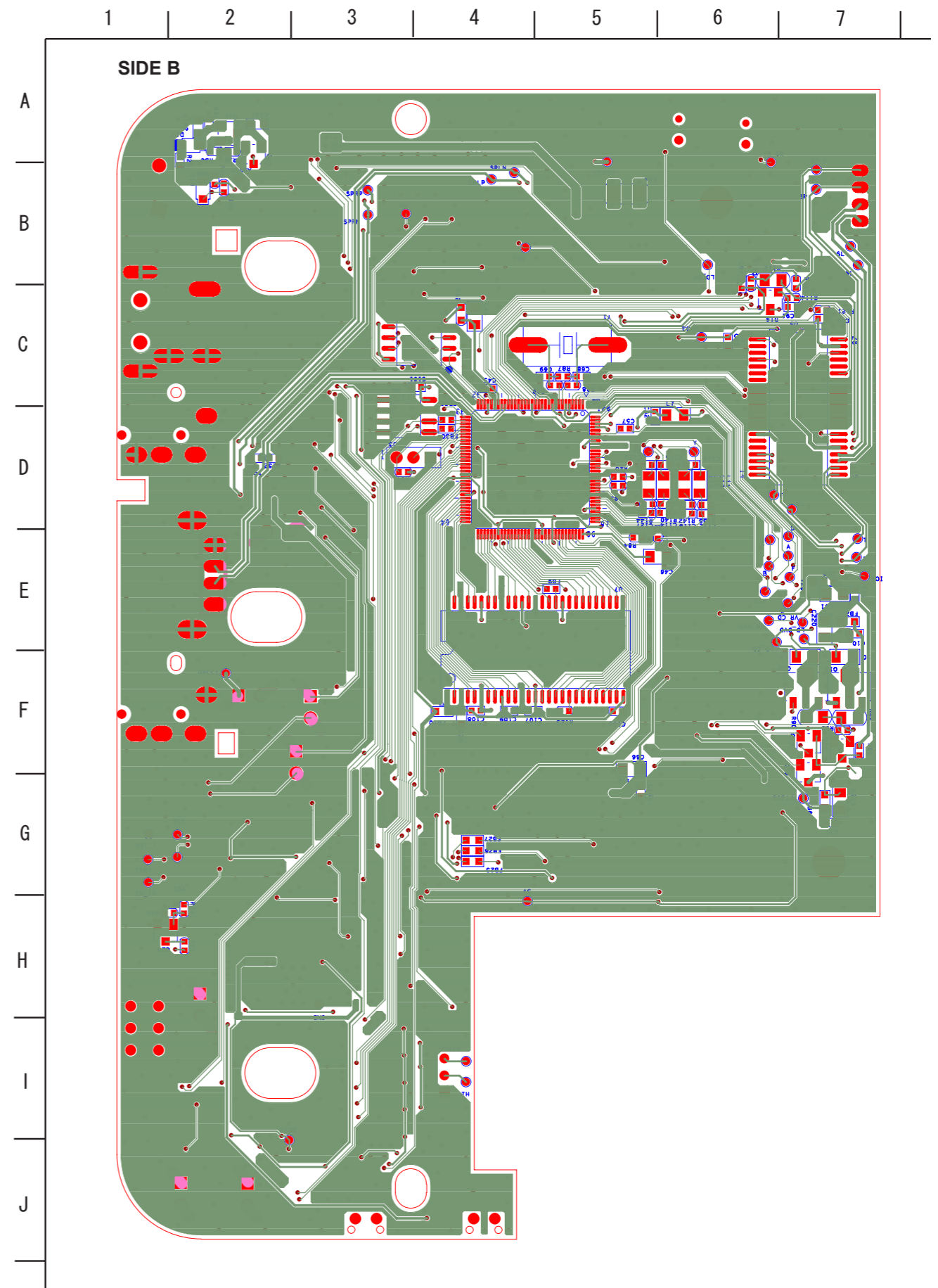
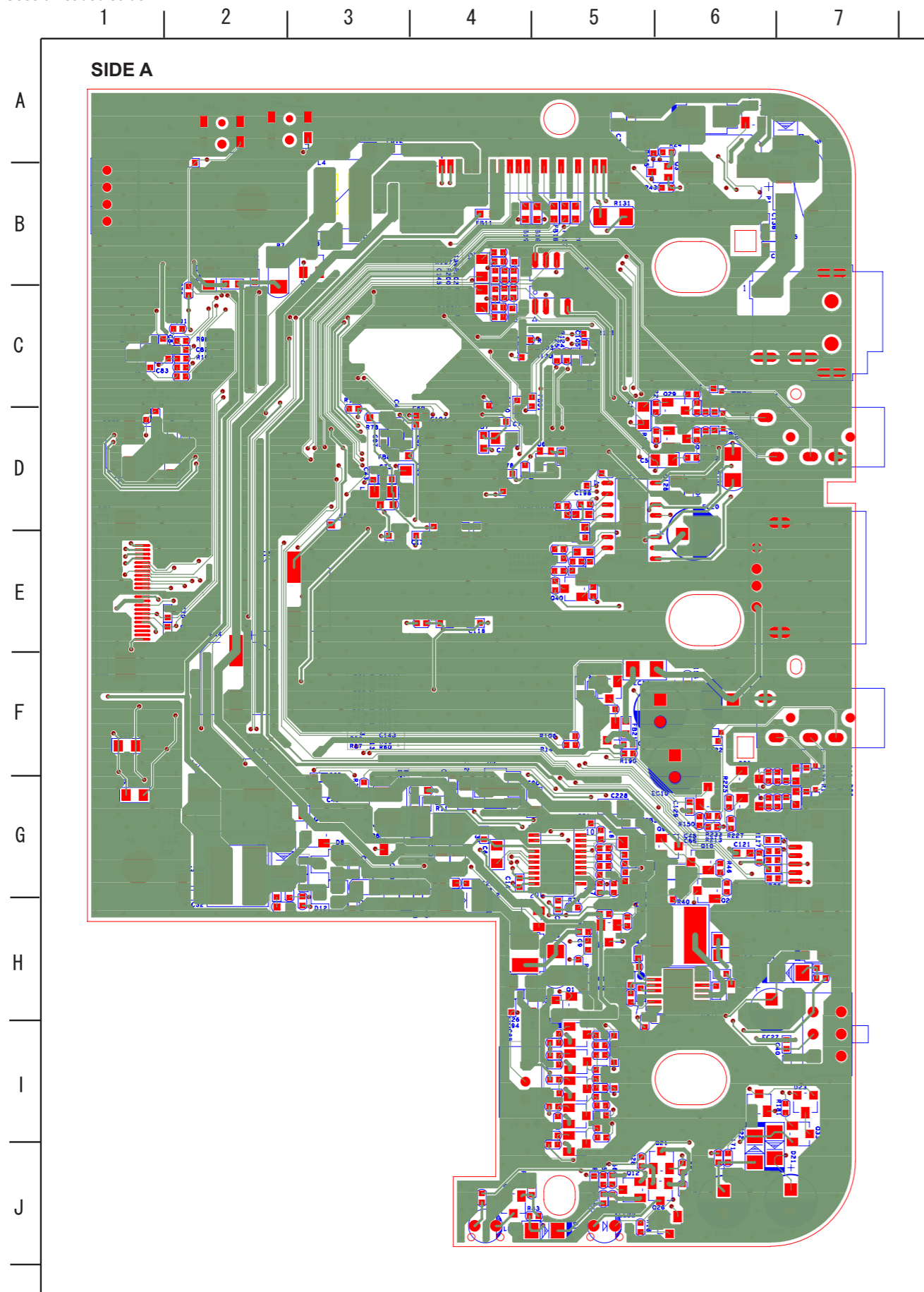

4-2. LCD BOARD

 : Uses unleaded solder.

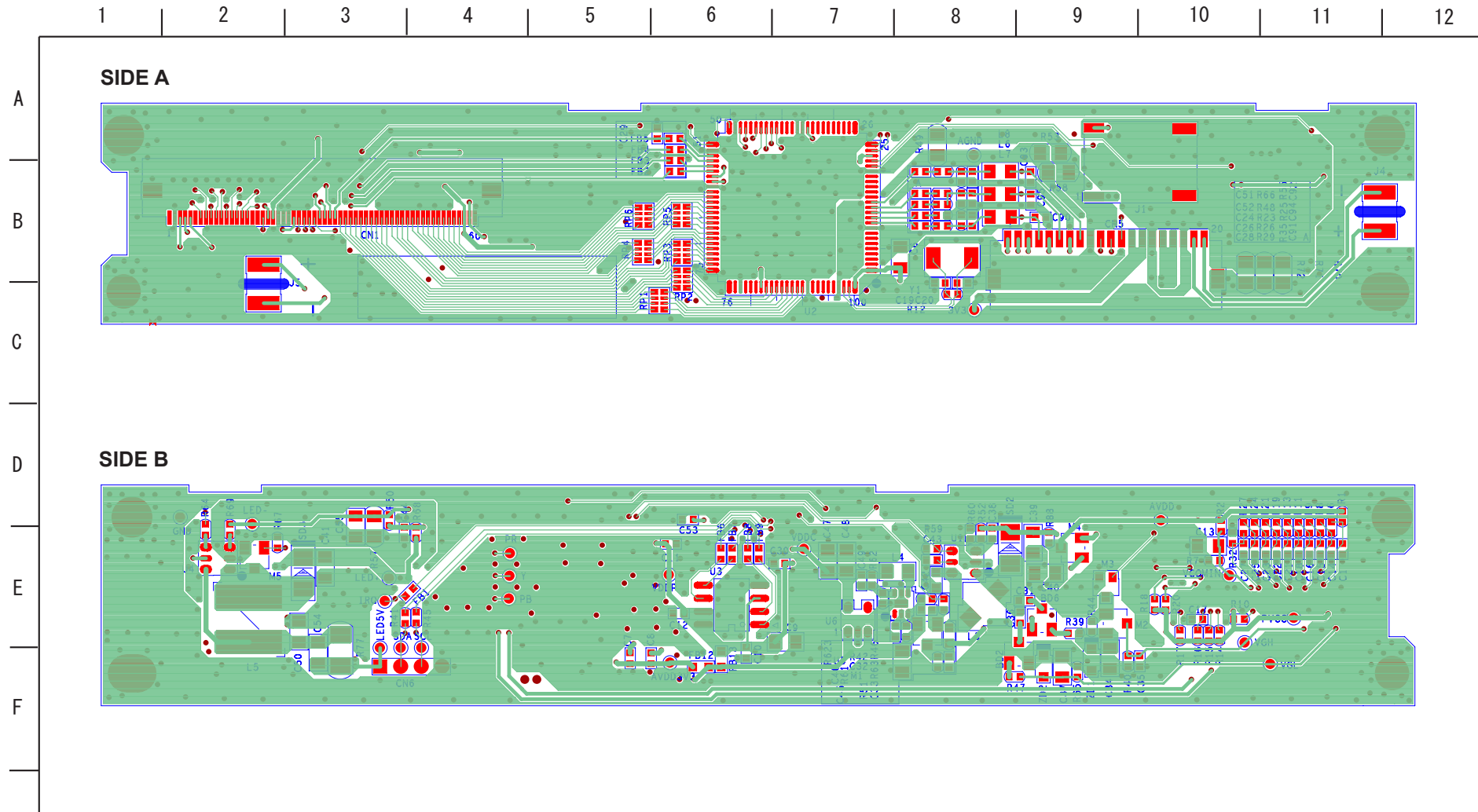

### 4-3. TOUCH BOARD

 : Uses unleaded solder.

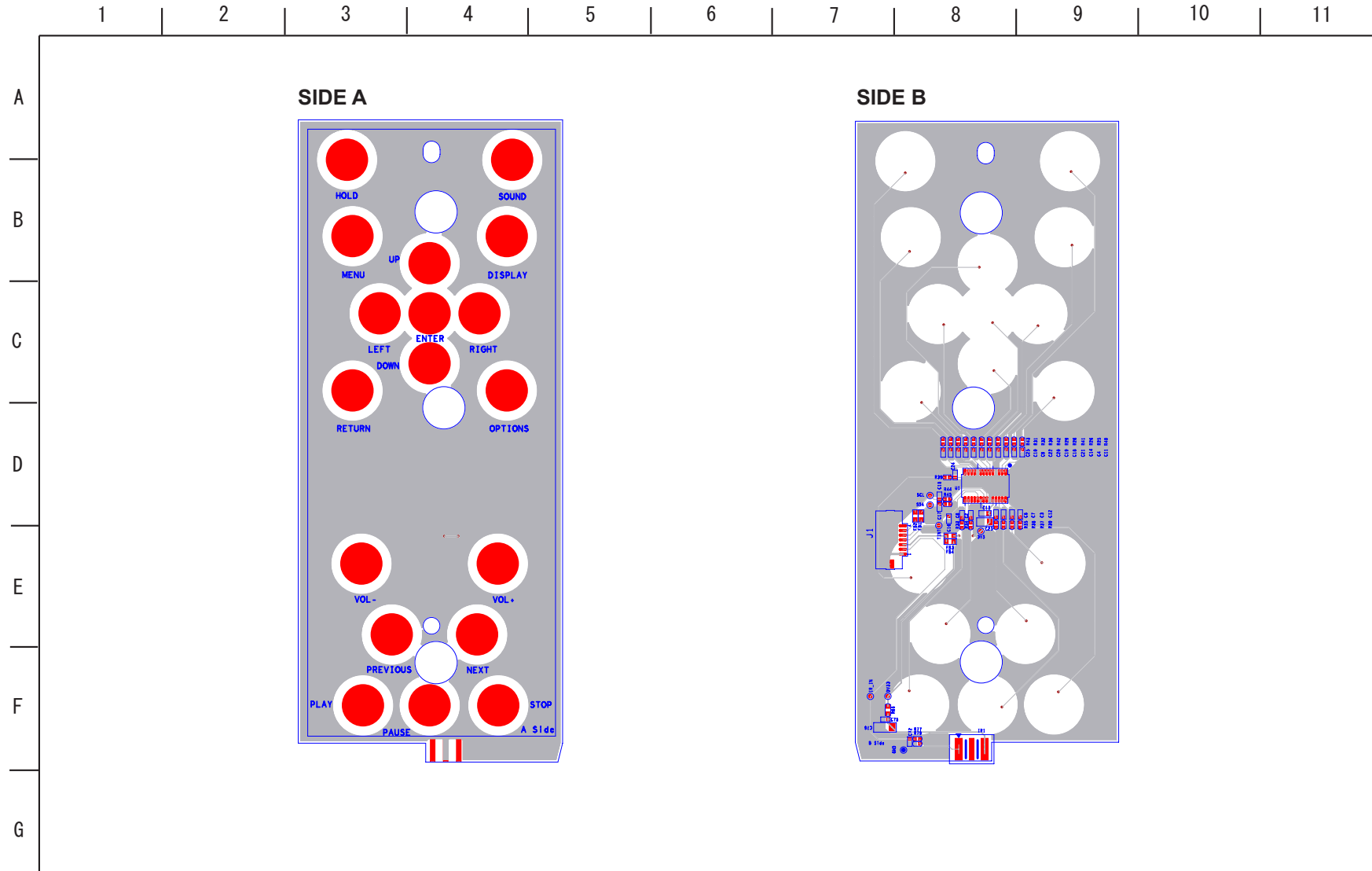

## SECTION 5 WAVEFORMS AND CIRCUIT VOLTAGE

### 5-1. WAVEFORMS

1.Spindle control waveform (No disc condition)

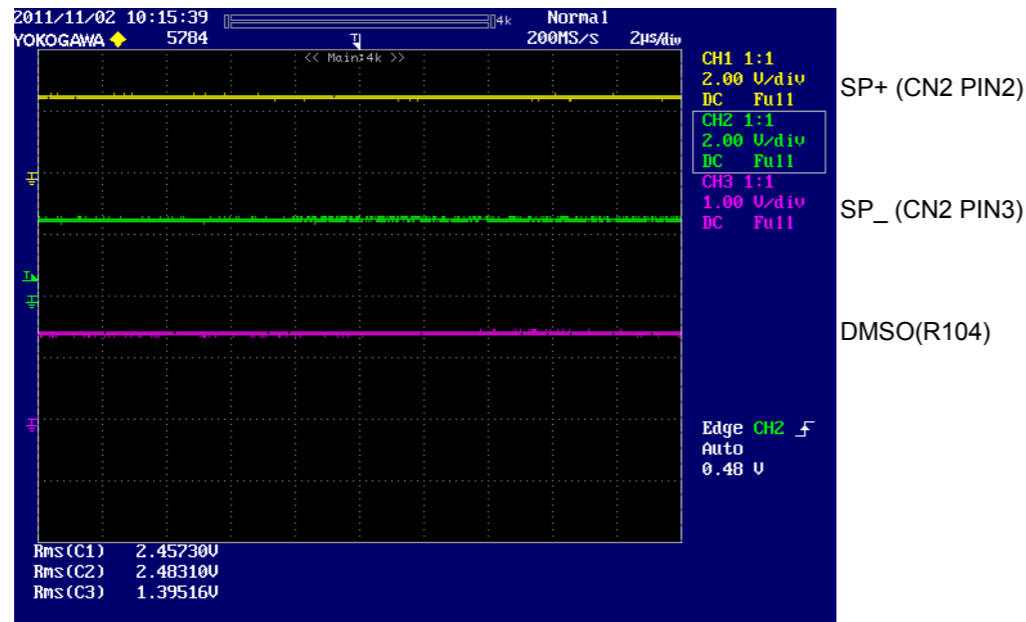

2.Tracking control relate signal (system checking CD )

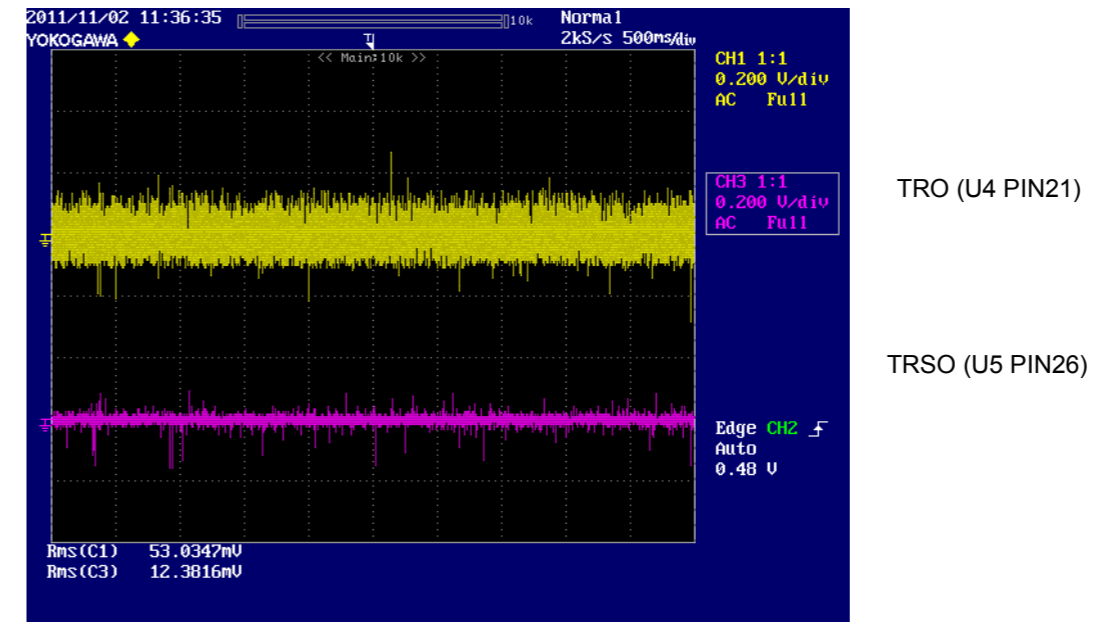

3. Tracking control relate signal (system checking-DVD)

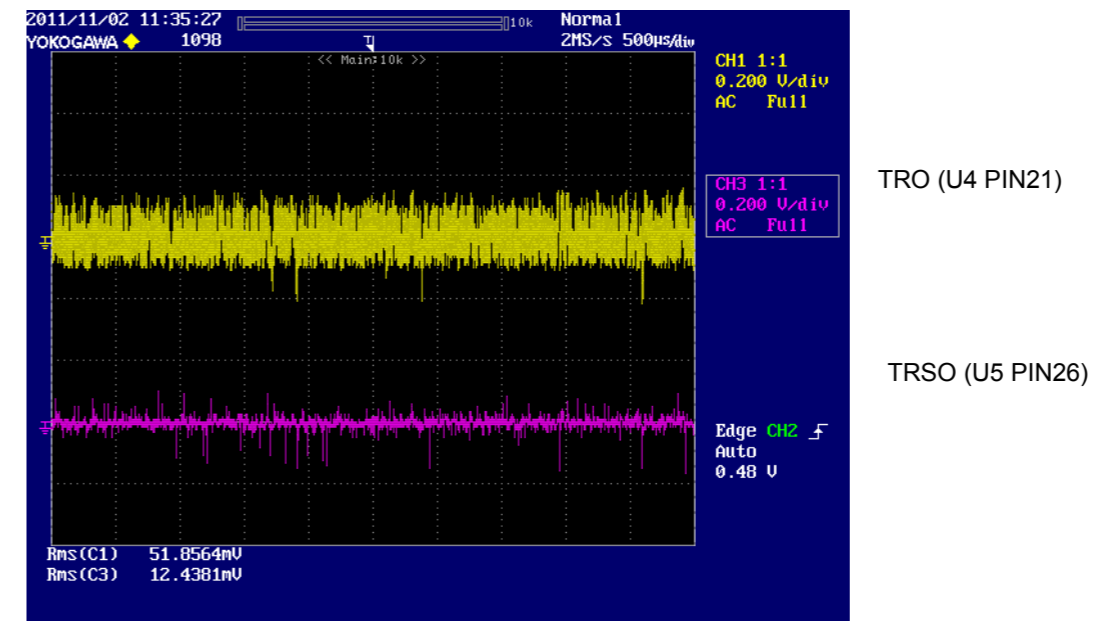

4. Audio output waveform (L/R)

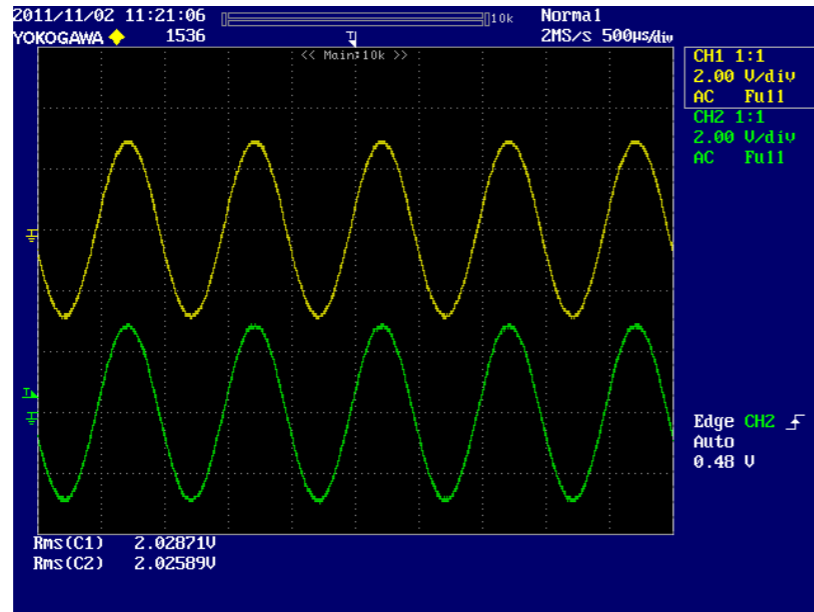

AUDIO L(J4 PIN2)

AUDIO R(J4 PIN1)

5. Video output waveform (CVBS)

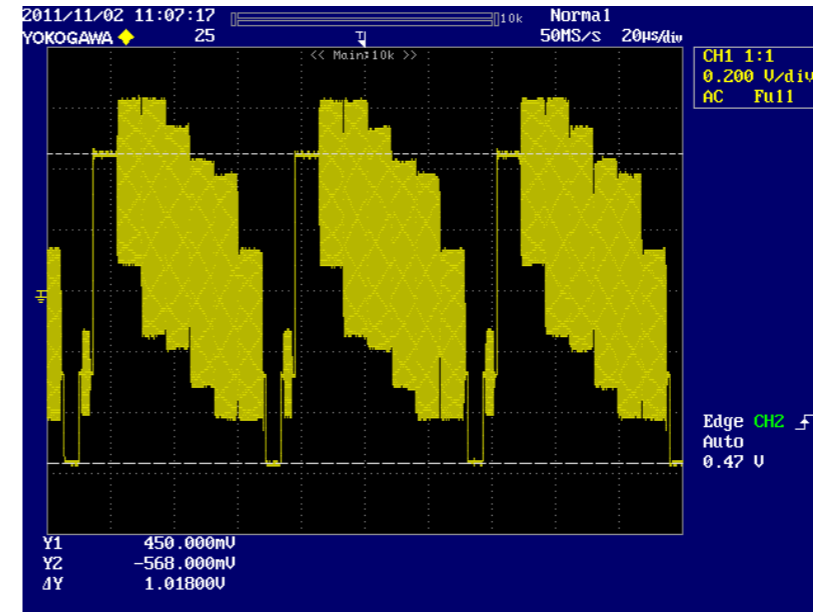

CVBS(J4 PIN3)

6. Video output waveform (Pr/Y/Pb)

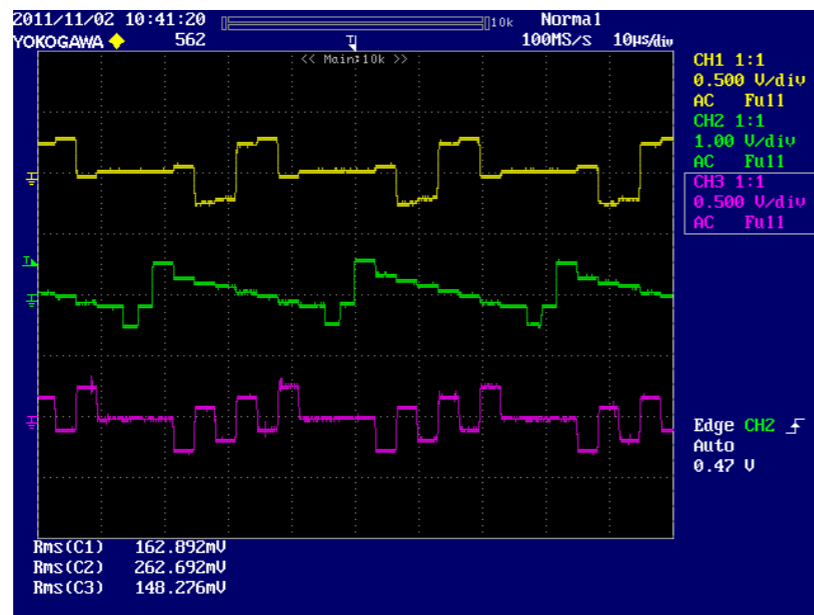

Pr (FB16)

Y (FB17)

Pb (FB20)

7. RF waveform

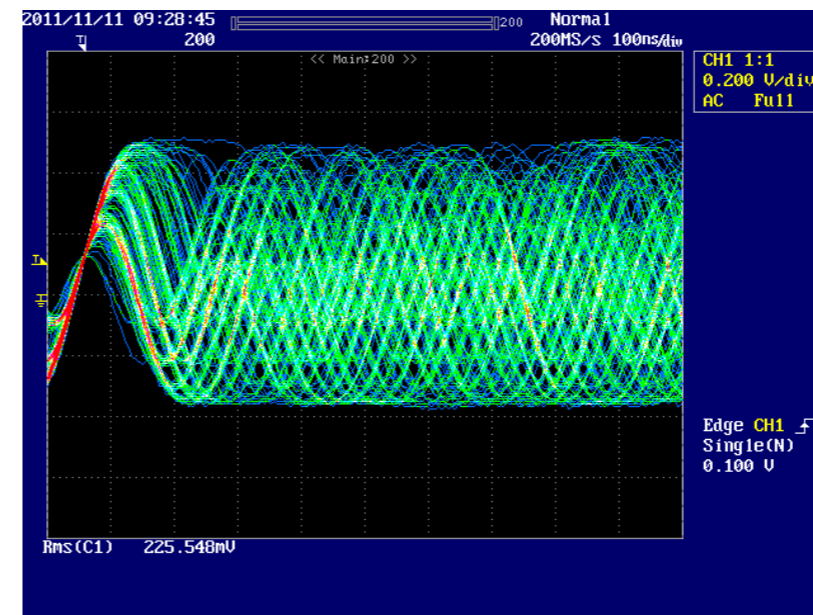

RFIP (U4 PIN 123)

## 5-2. CIRCUIT VOLTAGE CHART

U4(CXD9990R)			U4(CXD9990R)			U4(CXD9990R)			U4(CXD9990R)		
PIN	STOP(V)	PLAY(V)	PIN	STOP(V)	PLAY(V)	PIN	STOP(V)	PLAY(V)	PIN	STOP(V)	PLAY(V)
1	1.983	2.06	33	1.402	1.394	65	1.152	1.161	97	3.111	3.111
2	1.984	2.069	34	3.228	3.228	66	0.964	1.069	98	1.232	1.232
3	1.985	2.149	35	3.23	3.23	67	0.843	0.935	99	0	0
4	1.983	2.144	36	3.229	3.229	68	0.958	1.069	100	0.74	0.74
5	1.19	1.19	37	3.224	3.225	69	1.015	1.081	101	3.216	3.216
6	3.224	3.224	38	3.218	3.217	70	2.56	2.487	102	0.686	0.686
7	0.881	0.881	39	3.188	3.188	71	3.231	3.231	103	1.457	1.457
8	0.881	0.881	40	3.215	3.215	72	1.421	1.423	104	1.281	1.281
9	0	0	41	0	0	73	0.03	0.03	105	0	0
10	1.983	1.985	42	0	0	74	0.054	0.054	106	0.003	0.003
11	1.398	1.398	43	0	0	75	0.034	0.035	107	3.069	3.068
12	NC	NC	44	3.226	3.226	76	1.298	1.302	108	0	0
13	0.004	0.008	45	2.745	2.744	77	1.564	1.543	109	3.224	3.224
14	3.208	2.128	46	3.226	3.226	78	1.403	1.453	110	0	0
15	3.209	3.183	47	3.254	3.254	79	1.368	1.456	111	0	0
16	3.224	3.226	48	NC	NC	80	3.173	3.167	112	NC	NC
17	1.394	1.877	49	0	0	81	0	0	113	1.61	1.611
18	1.394	1.395	50	0	0	82	2.992	2.972	114	1.626	1.626
19	0.037	0.037	51	3.231	3.231	83	3.122	3.119	115	1.628	1.628
20	0.004	0.162	52	1.156	1.179	84	3.231	3.231	116	1.626	1.626
21	1.387	1.392	53	0.971	1.038	85	1.015	1.163	117	NC	NC
22	1.39	1.417	54	0.891	0.961	86	1.646	1.495	118	NC	NC
23	3.22	0	55	1.015	1.07	87	1.188	1.188	119	3.225	3.225
24	0	0	56	1.187	1.171	88	0.032	0.032	120	3.225	3.225
25	0	0	57	1.122	1.171	89	0.309	0.379	121	1.187	1.187
26	3.32	3.32	58	0.71	0.826	90	2.435	2.402	122	0	0
27	0	0	59	0.656	0.761	91	2.416	2.336	123	0.891	0.891
28	0.767	0.767	60	0.765	0.905	92	1.585	1.519	124	NC	NC
29	1.186	1.186	61	2.559	2.512	93	0	0	125	2.496	1.642
30	0.204	0.195	62	0.652	0.779	94	2.438	2.438	126	2.499	1.622
31	1.23	1.587	63	1.314	1.392	95	NC	NC	127	1.986	2.067
32	0.215	0.256	64	1.241	1.356	96	3.217	3.217	128	1.985	2.065

U7(SDRAM)			U7(SDRAM)			U13(APA2068KA)			U5(AM5890S)		
PIN	STOP(V)	PLAY(V)	PIN	STOP(V)	PLAY(V)	PIN	STOP(V)	PLAY(V)	PIN	STOP(V)	PLAY(V)
1	3.216	3.216	28	0	0	1	0	0	1	1.396	1.399
2	1.162	1.16	29	1.37	1.444	2	3.477	3.477	2	NC	NC
3	3.217	3.217	30	1.401	1.451	3	2.524	2.524	3	NC	NC
4	0.961	1.021	31	1.562	1.54	4	2.523	2.523	4	1.396	1.405
5	0.87	0.919	32	1.297	1.306	5	0	0	5	NC	NC
6	0	0	33	0.034	0.035	6	2.523	2.523	6	NC	NC
7	1.003	1.064	34	0.054	0.054	7	1.23(vol 10)	1.23(vol 10)	7	NC	NC
8	1.104	1.174	35	0.015	0.03	8	0	0	8	5.109	5.108
9	3.217	3.217	36	NC	NC	9	2.542	2.542	9	NC	NC
10	0.694	0.814	37	3.215	3.213	10	5.108	5.099	10	NC	NC
11	0.631	0.736	38	1.411	1.412	11	2.543	2.543	11	2.481	3.287
12	0	0	39	2.559	2.511	12	0	0	12	2.498	1.657
13	0.755	0.917	40	NC	NC	13	0.118	0.119	13	2.487	2.487
14	3.216	3.216	41	0	0	14	2.543	2.543	14	2.482	2.49
15	2.557	2.512	42	0.987	1.086	15	5.108	5.099	15	2.484	2.481
16	3.174	3.171	43	3.217	3.216	16	2.539	2.539	16	2.498	2.468
17	2.994	2.976	44	0.962	1.083				17	2.487	2.486
18	3.123	3.119	45	0.832	0.946				18	2.502	2.516
19	0.007	0.002	46	0	0				19	5.109	5.097
20	1.037	1.125	47	0.932	1.085				20	NC	NC
21	1.643	1.492	48	1.136	1.256				21	2.555	2.549
22	0.032	0.032	49	3.217	3.216				22	0	0
23	0.308	0.332	50	1.229	1.358				23	1.401	1.402
24	2.433	2.401	51	1.316	1.436				24	NC	NC
25	2.414	2.352	52	0	0				25	NC	NC
26	1.585	1.515	53	0.64	0.129				26	1.395	1.396
27	3.217	3.216	54	0	0				27	1.399	1.398
U9(FLASH)			U12(AZ4558)			U8(EEPROM)			28	3.22	3.22
PIN	STOP(V)	PLAY(V)	PIN	STOP(V)	PLAY(V)	PIN	STOP(V)	PLAY(V)	29	0	0
1	0.664	0.661	1	0	0	1	0	0	30	0	0
2	1.92	1.87	2	0	0	2	0	0			
3	3.22	3.251	3	0	0	3	0	0			
4	0	0	4	-5.11	-5.11	4	0	0			
5	1.61	1.65	5	0	0	5	3.295	3.295			
6	1.18	1.19	6	0	0	6	3.295	3.295			
7	3.22	3.251	7	0	0	7	0	0			
8	3.22	3.251	8	5.115	5.11	8	3.295	3.295			

## SECTION 6 IC PIN FUNCTION DESCRIPTION

### 6-1. SERVO & DSP & MPEG IC (MAIN BOARD)

<b>CXD9990R</b>			
Pin	Main	Type	Description
1	RFC	Analog input	RF main beam input C
2	RFD	Analog input	RF main beam input D
3	RFE	Analog input	RF main beam input E
4	RFF	Analog input	RF main beam input F
5	AVDD12_2	Analog power	Analog 1.2V power
6	AVDD33_1	Analog power	Analog 3.3V power
7	XTALI	input	27MHz crystal input
8	XTALO	output	27MHz crystal output
9	AGND33	AGND	Analog Ground
10	V20	Analog output	Reference voltage 2.0V
11	V14	Analog output	Reference voltage 1.4V
12	REXT	Analog output	GPIO5(ADSP_RST)
13	MDH	Analog input	Laser power monitor input
14	LD01	Analog output	Laser driver output (CD)
15	LD02	Analog output	Laser driver output (DVD)
16	AVDD33_2	Analog power	Analog 3.3V power
17	DMO	Analog output	Disk motor control. PWM output
18	FMO	Analog output	Feed motor control. PWM output
19	TRAY_OPEN	Analog output	Tray PWM Output
20	TRAY_CLOS	Analog output	GPIO(VR_DVD)
21	TRO	Analog output	Tracking servo output. PDM output of tracking servo compensator
22	FOO	Analog output	Focus servo output. PDM output of focus servo compensator
23	FG	Analog	GPIO(TR_III)
24	USB_DM	Analog input	USB port DPLUS analog pin
25	USB_DP	Analog input	USB port DMINUS analog pin
26	VDD33_USB	USB power	USB Power pin 3.3V
27	VSS33_USB	USB GND	USB ground pin
28	PAD_VRT	Analog input	USB generating reference current
29	VDD12_USB	USB power	USB Power pin 1.2V
30	SF_CS	input/output	Serial Flash Chip Select
31	SF_D0	input/output	Serial Flash Dout
32	SF_DI	input/output	Serial Flash Din
33	SF_CK	input/output	Serial Flash Clock
34	UP1_6	input/output	I <sup>2</sup> C SCK
35	UP1_7	input/output	I <sup>2</sup> C SDA
36	GPIO11	input/output	RXD
37	GPIO6	input/output	TXD
38	PRST#	input	Power on reset input, active low
39	IR	input	IR control signal input
40	GPIO3	input/output	GPIO(STBY)
41	GPIO4	input/output	GPIO(IOA)
42	GPIO13	input/output	GPIO(BAT_B)
43	GPIO9	input/output	GPIO(BAT_C)
44	GPIO8	input/output	GPIO(Reset_T)
45	GPIO7	input/output	GPIO(TFT_IRQ)
46	GPIO29	input/output	GPIO(POWER_KEY)
47	GPIO30	input/output	GPIO(TIHT)
48	GPIO31	input/output	GPIO(ADAPTER_DET)
49	GPIO32	input/output	GPIO(5V_SB)
50	DVSS33	GND	3.3V Ground pin for internal digital circuitry
51	DVDD33	Power	3.3V power pin for internal digital circuitry
52	RD0	input/output	DRAM data 0
53	RD1	input/output	DRAM data 1
54	RD2	input/output	DRAM data 2
55	RD3	input/output	DRAM data 3
56	DVDD12	Power	1.2V power pin for internal digital circuitry
57	RD4	input/output	DRAM data 4
58	RD5	input/output	DRAM data 5
59	RD6	input/output	DRAM data 6
60	RD7	input/output	DRAM data 7
61	DOM0	input/output	Data Mask 0
62	RD15	input/output	DRAM data 15
63	RD14	input/output	DRAM data 14

64	RD13	input/output	DRAM data 13
65	RD12	input/output	DRAM data 12
66	RD11	input/output	DRAM data 11
67	RD10	input/output	DRAM data 10
68	RD9	input/output	DRAM data 9
69	RD8	input/output	DRAM data 8
70	DQM1	input/output	Data Mask 1
71	DVDD33	Power	3.3V power pin for internal digital circuitry
72	RCLK	input/output	DRAM clock
73	RA11	input/output	DRAM address 11
74	RA9	input/output	DRAM address 9
75	RA8	input/output	DRAM address 8
76	RA7	input/output	DRAM address 7
77	RA6	input/output	DRAM address 6
78	RA5	input/output	DRAM address 5
79	RA4	input/output	DRAM address 4
80	RWE#	output	DRAM Write enable, active low
81	DVSS12	GND	1.2V ground pin for internal digital circuitry
82	CAS#	output	DRAM Column address strobe, active low
83	RAS#	output	DRAM row address strobe, active low
84	DVDD33	Power	3.3V power pin for internal digital circuitry
85	BA0	input/output	DRAM bank address 0
86	BA1	input/output	DRAM bank address 1
87	DVDD12	Power	1.2V power pin for internal digital circuitry
88	RA10	input/output	DRAM address 10
89	RA0	input/output	DRAM address 0
90	RA1	input/output	DRAM address 1
91	RA2	input/output	DRAM address 2
92	RA3	input/output	DRAM address 3
93	SPDIF	input/output	GPIO(BAT_D)
94	GPIO10	input/output	GPIO(EAR_DE)
95	GPIO33	input/output	GPIO(BAT_A)
96	DACVDDC	Power	3.3V Power pin for video DAC circuitry
97	VREF	Analoutputg	GPIO(MUTE)
98	FS	Analoutputg	Full scale adjustment (suggest to use 560 ohm)
99	DACVSSC	GND	Ground pin for video DAC circuitry
100	CVBS	Analoutputg	Analog composite output
101	DACVDDB	Power	3.3V Power pin for video DAC circuitry
102	Y/G	Analoutputg	Green, Y, SY, or CVBS
103	B/CB/PB	Analoutputg	Blue, CB/PB or SC
104	R/CR/PR	Analoutputg	Red, CR/PR, CVBS or SY
105	AADVSS	GND	Ground pin for 2ch audio ADC circuitry
106	AKIH2	Analoutputg	GPIO(CHARGE_LED)
107	ADVCM	Analoutputg	GPIO(AV_CTRL)
108	AKIH1	Analoutputg	GPIO(HOLD)
109	AADVDD	Power	3.3V Power pin for 2ch audio ADC circuitry
110	ADACVSS2	GND	Ground pin for audio DAC circuitry
111	ADACVSS1	GND	Ground pin for audio DAC circuitry
112	ARF/LFE	Analog output	GPIO(ACLK_1)
113	ARS	Analog output	GPIO(BCK_1)
114	AR	Analog output	GPIO(USB_EH)
115	AVCM	Analog	Audio DAC Reference voltage
116	AL	Analog output	GPIO(AUDIO_DE)
117	ALS	Analog output	GPIO(LRCK_1)
118	ALF/CENTER	Analog output	GPIO(SDII_1)
119	ADACVDD1	Power	3.3V Power pin for audio DAC circuitry
120	ADACVDD2	Power	3.3V Power pin for audio DAC circuitry
121	AVDD12_1	Power	Analog 1.2V power
122	AGND12	GND	Analog 1.2V Ground
123	RFIP	Analog input	AC Coupled DVD RF signal input RFIP
124	RFIH	Analog input	GPIO(LIMIT)
125	RFG	Analog input	Main beam, RF AC input path
126	RFH	Analog input	Main beam, RF AC input path
127	RFA	Analog input	RF main beam input A
128	RFB	Analog input	RF main beam input B

## SECTION 7 ELECTRICAL ADJUSTMENT

This section describes procedures and instructions necessary for adjusting electrical circuits in this set.

### Instruments required:

- 1) Color monitor TV
- 2) Oscilloscope 1 or 2 phenomena, band width over 100 MHz, with delay mode
- 3) Frequency counter (over 8 digits)
- 4) Digital voltmeter
- 5) Standard commander (RMT-D195)
- 6) DVD reference disc
  - HLX-504 (J-6090-088-A) (single layer) (NTSC)
  - HLX-505 (J-6090-089-A) (dual layer) (NTSC)

### 7-1. STANDARD VIDEO LEVEL

#### 1. Checking Video Output Level

##### <Purpose>

This checks whether video output level satisfy the NTSC standard. If it is not correct, the brightness will be too large or small.

Mode	Play
Signal	Check the color-bar (100%) signal on DVD reference disc
Measurement Point	LINE OUT (VIDEO) connector (75 $\Omega$ terminated)
Measuring Instrument	Oscilloscope
Specification	$1.00 \pm 0.05$ Vp-p

##### Checking method:

- 1) Confirm that the video output level is  $1.00 \pm 0.05$  Vp-p.

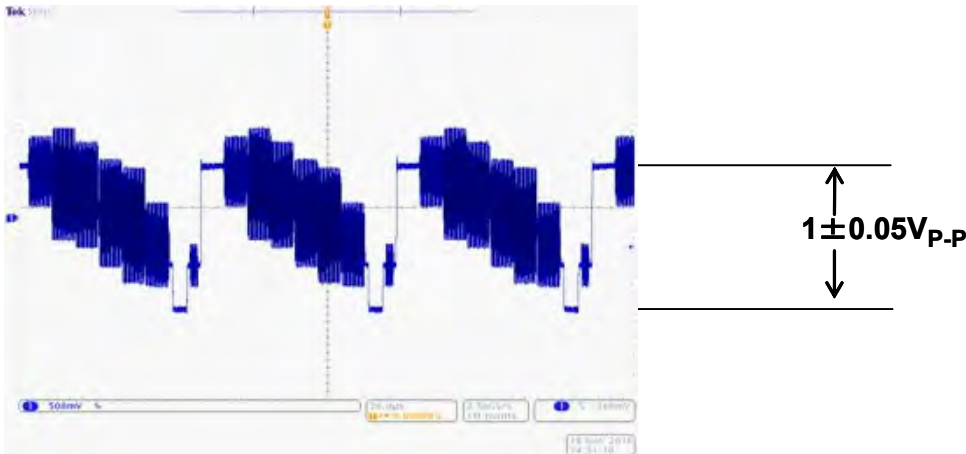

## SECTION 8 TROUBLESHOOTING

### 8-1. ELECTRICAL TROUBLE SHOOTING GUIDE

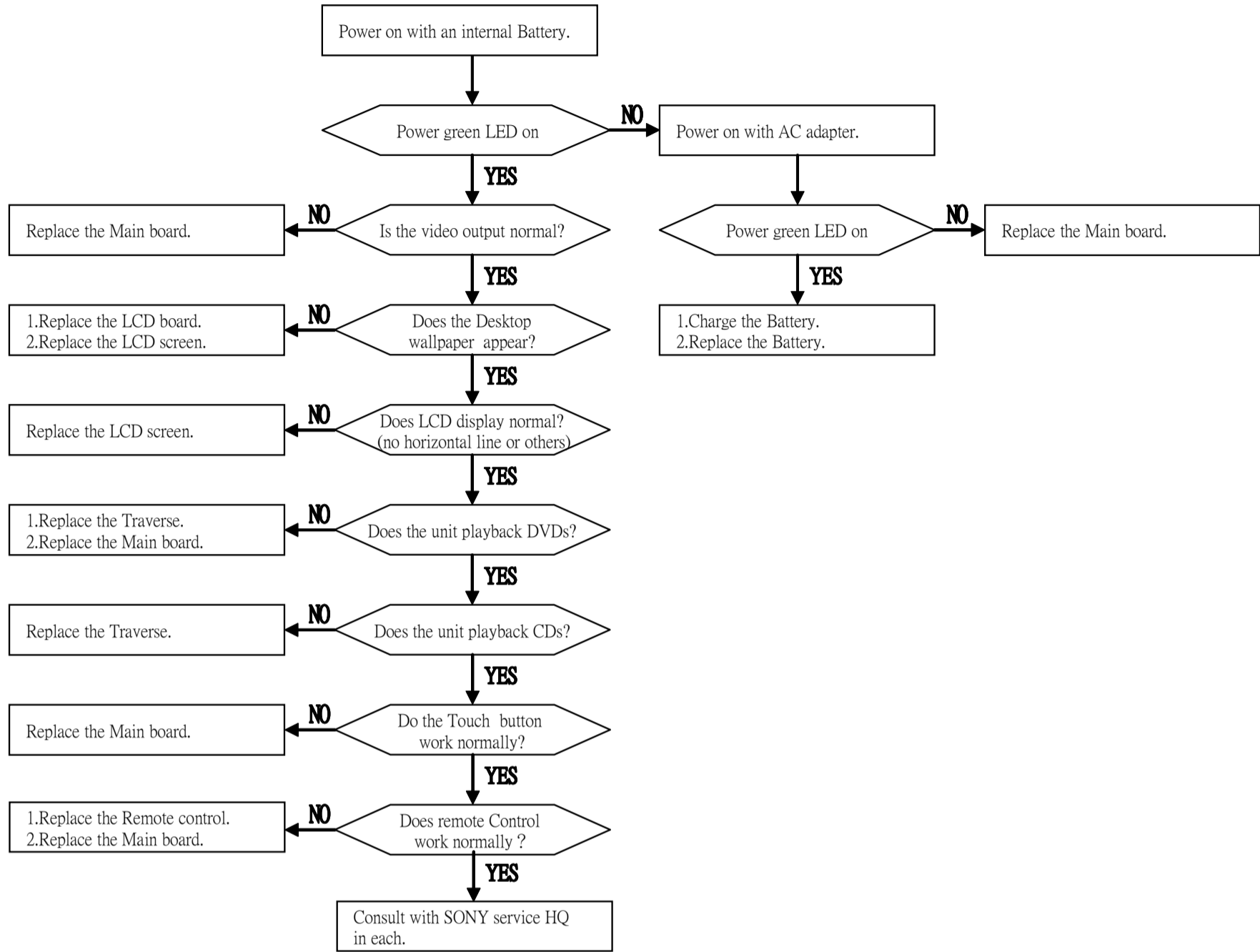



9-1-3. UPPER BLOCK

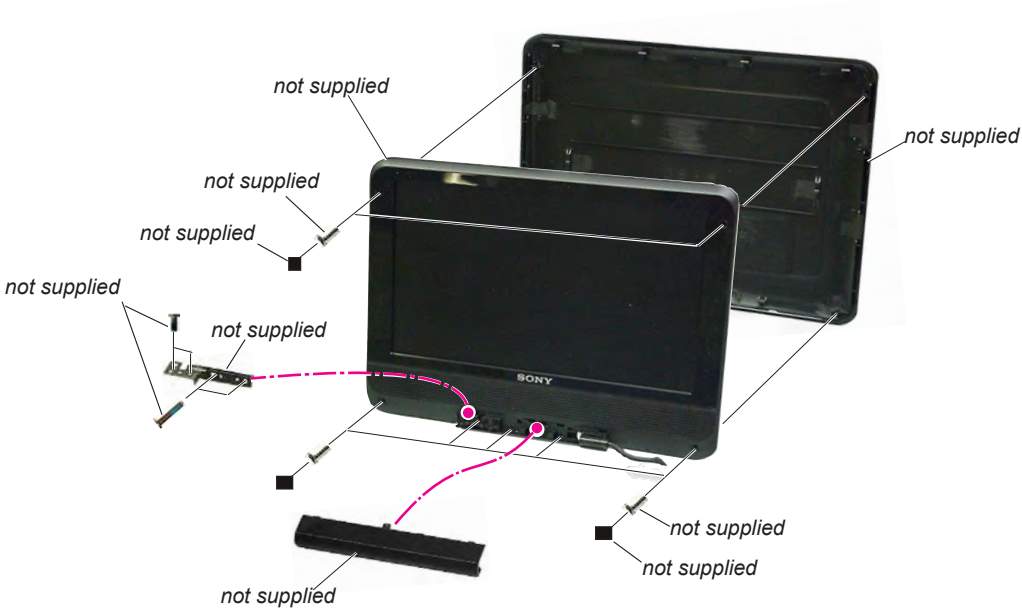

9-1-4. LCD SCREEN/ LCD BOARD

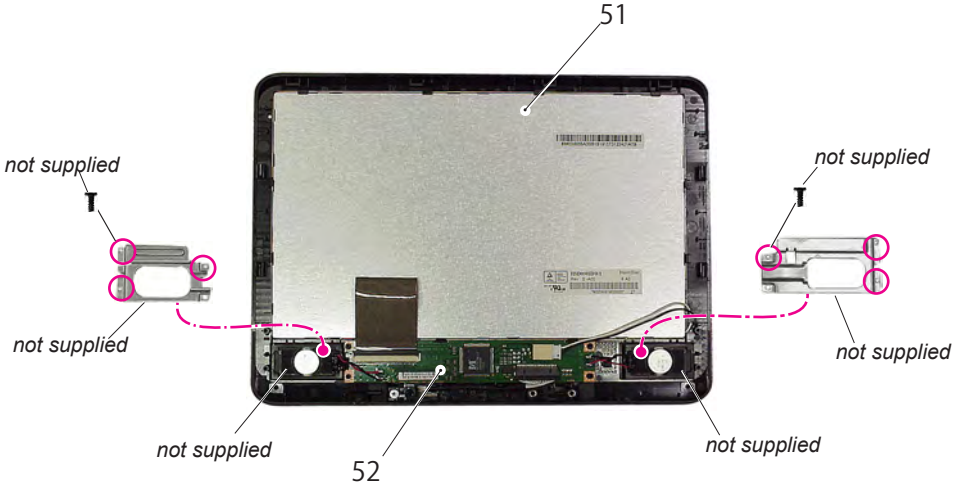

Ref. No.	Part No.	Description	Remark
51	9-885-160-75	9" LCD SCREEN(76040M800-535-G)	
52	9-885-167-66	LCD BOARD ASSY(02-06049811-00)	

9-1-5. ACCESSORIES

101 Remote commander



102 AC adaptor



103 Car battery adaptor



104 AV adaptor



105 Operating Instructions



Image: 4-411-682-11 (US)

Ref. No.	Part No.	Description	Remark
101	1-487-884-11	REMOTE COMMANDER (RMT-D195)	
△ 102	9-885-167-46	AC-FX190 (SP-12A1200950-U)	
△ 103	9-885-167-56	DCC-FX190 (SKY-E201106001)	
104	9-885-167-59	AV Adaptor (010-0001-386)	
105	4-411-682-11	MANUAL, INST. (084-0001-6525)	(US)
105	4-411-682-21	MANUAL, INST. (084-0002-6525)	(CND)

<p>The components identified by mark △ or dotted line with mark △ are critical for safety. Replace only with part number specified.</p> <p>Les composants identifiés par une marque △ sont critiques pour la sécurité. Ne les remplacer que par une pièce portant le numéro spécifié.</p>
---

