

# DSC-W90

## SERVICE MANUAL

LEVEL 2

Ver. 1.2 2007.07

Revision History

About this  
service manual

Internal memory  
ON BOARD

Revised-1



Photo: Silver

US Model  
Canadian Model  
AEP Model  
UK Model  
E Model  
Australian Model  
Hong Kong Model  
Chinese Model  
Korea Model  
Argentine Model  
Brazilian Model

### Link

<a href="#">SPECIFICATIONS</a>	<a href="#">BLOCK DIAGRAMS</a>	<a href="#">PRINTED WIRING BOARDS</a>
<a href="#">SERVICE NOTE</a>	<a href="#">FRAME SCHEMATIC DIAGRAM</a>	<a href="#">REPAIR PARTS LIST</a>
<a href="#">DISASSEMBLY</a>	<a href="#">SCHEMATIC DIAGRAMS</a>	

#### • Precaution on Replacing the SY-169 Board

The components identified by mark  $\triangle$  or dotted line with mark  $\triangle$  are critical for safety. Replace only with part number specified.

Les composants identifiés par une marque  $\triangle$  sont critiques pour la sécurité. Ne les remplacer que par une pièce portant le numéro spécifié.

DIGITAL STILL CAMERA

SONY®



Cyber-shot



## SPECIFICATIONS

### Camera

#### [System]

Image device:

7.18 mm (1/2.5 type) color CCD,  
Primary color filter

Total pixel number of camera:

Approx. 8 286 000 pixels

Effective pixel number of camera:

Approx. 8 083 000 pixels

Lens: Carl Zeiss Vario-Tessar 3× zoom lens f =  
5.8 – 17.4 mm (35 – 105 mm when converted  
to a 35 mm still camera) F2.8 – 5.2

Exposure control: Automatic exposure, Scene  
Selection (7 modes)

White balance: Automatic, Daylight, Cloudy,  
Fluorescent 1,2,3, Incandescent, Flash

File format (DCF compliant):

Still images: Exif Ver. 2.21 JPEG compliant,  
DPOF compatible

Movies: MPEG1 compliant (Monaural)

Recording media: Internal Memory (approx.  
31 MB), "Memory Stick Duo"

Flash:Flash range (ISO sensitivity

(Recommended exposure Index) set to Auto):  
approx. 0.2 to 3.3 m (7 7/8 inches to 10 feet  
10 inches) (W)/approx. 0.4 to 1.8 m (1 foot  
3 3/4 inches to 5 feet 10 7/8 inches) (T)

#### [Input and Output connectors]

Multi connector Video output  
Audio output (Monaural)

USB communication

USB communication: Hi-Speed USB (USB 2.0  
compliant)

#### [LCD screen]

LCD panel: 6.2 cm (2.5 type) TFT drive

Total number of dots: 115 200 (480 × 240) dots

#### [Power, general]

Power: Rechargeable battery pack NP-BG1, 3.6 V  
AC-LS5K AC Adaptor (not supplied), 4.2 V

Power consumption (during shooting with the  
LCD screen on): 1.1W

Operating temperature: 0 to 40°C (32 to 104°F)

Storage temperature: –20 to +60°C (–4 to +140°F)

Dimensions: 91.0 × 58.0 × 22.9 mm (3 5/8 ×  
2 3/8 × 29/32 inches) (W/H/D, excluding  
protrusions)

Mass: Approx. 155 g (5.5 oz) (including NP-  
BG1 battery pack and strap, etc.)

Microphone: Monaural

Speaker: Monaural

Exif Print: Compatible

PRINT Image Matching III: Compatible

PictBridge: Compatible

### BC-CSG/BC-CSGB/BC-CSGC battery charger

Power requirements: AC 100 to 240 V, 50/60 Hz,  
2 W (BC-CSG/BC-CSGC)/ 2.6 W (BC-  
CSGB)

Output voltage: DC 4.2 V, 0.25 A

Operating temperature: 0 to 40°C (32 to 104°F)

Storage temperature: –20 to +60°C (–4 to  
+140°F)

Dimensions: Approx. 62 × 24 × 91 mm (2 1/2 ×  
3 1/32 × 3 5/8 inches) (W/H/D)

Mass: Approx. 75 g (2.7 oz)

### Rechargeable battery pack NP- BG1

Used battery: Lithium-ion battery

Maximum voltage: DC 4.2 V

Nominal voltage: DC 3.6 V

Capacity: 3.4 Wh (960 mAh)

Design and specifications are subject to change  
without notice.

**CAUTION**

Danger of explosion if battery is incorrectly replaced.  
Replace only with the same or equivalent type.

**SAFETY-RELATED COMPONENT WARNING!!**

COMPONENTS IDENTIFIED BY MARK  $\triangle$  OR DOTTED LINE WITH MARK  $\triangle$  ON THE SCHEMATIC DIAGRAMS AND IN THE PARTS LIST ARE CRITICAL TO SAFE OPERATION. REPLACE THESE COMPONENTS WITH SONY PARTS WHOSE PART NUMBERS APPEAR AS SHOWN IN THIS MANUAL OR IN SUPPLEMENTS PUBLISHED BY SONY.

**ATTENTION AU COMPOSANT AYANT RAPPORT  
À LA SÉCURITÉ!**

LES COMPOSANTS IDENTIFIÉS PAR UNE MARQUE  $\triangle$  SUR LES DIAGRAMMES SCHÉMATIQUES ET LA LISTE DES PIÈCES SONT CRITIQUES POUR LA SÉCURITÉ DE FONCTIONNEMENT. NE REMPLACER CES COMPOSANTS QUE PAR DES PIÈCES SONY DONT LES NUMÉROS SONT DONNÉS DANS CE MANUEL OU DANS LES SUPPLÉMENTS PUBLIÉS PAR SONY.

## SAFETY CHECK-OUT

After correcting the original service problem, perform the following safety checks before releasing the set to the customer.

1. Check the area of your repair for unsoldered or poorly-soldered connections. Check the entire board surface for solder splashes and bridges.
2. Check the interboard wiring to ensure that no wires are "pinched" or contact high-wattage resistors.
3. Look for unauthorized replacement parts, particularly transistors, that were installed during a previous repair. Point them out to the customer and recommend their replacement.
4. Look for parts which, through functioning, show obvious signs of deterioration. Point them out to the customer and recommend their replacement.
5. Check the B+ voltage to see it is at the values specified.
6. FLEXIBLE Circuit Board Repairing
  - Keep the temperature of the soldering iron around 270°C during repairing.
  - Do not touch the soldering iron on the same conductor of the circuit board (within 3 times).
  - Be careful not to apply force on the conductor when soldering or unsoldering.

### Unleaded solder

Boards requiring use of unleaded solder are printed with the lead-free mark (LF) indicating the solder contains no lead.

(Caution: Some printed circuit boards may not come printed with the lead free mark due to their particular size.)



### **LF : LEAD FREE MARK**

Unleaded solder has the following characteristics.

- Unleaded solder melts at a temperature about 40°C higher than ordinary solder.  
Ordinary soldering irons can be used but the iron tip has to be applied to the solder joint for a slightly longer time.  
Soldering irons using a temperature regulator should be set to about 350°C.  
Caution: The printed pattern (copper foil) may peel away if the heated tip is applied for too long, so be careful!
- Strong viscosity  
Unleaded solder is more viscous (sticky, less prone to flow) than ordinary solder so use caution not to let solder bridges occur such as on IC pins, etc.
- Usable with ordinary solder  
It is best to use only unleaded solder but unleaded solder may also be added to ordinary solder.

# 1. SERVICE NOTE

## 1-1. PRECAUTION ON REPLACING THE SY-169 BOARD

### DESTINATION DATA

When you replace to the repairing board, the written destination data of repairing board also might be changed to original setting. Refer to Service Manual ADJ, and perform "DESTINATION DATA WRITE".

### USB SERIAL No.

The set is shipped with a unique ID (USB Serial No.) written in it.

This ID has not been written in a new board for service, and therefore it must be entered after the board replacement.

Refer to Service Manual ADJ, and perform "USB SERIAL No. INPUT".

## 1-2. SELF-DIAGNOSIS FUNCTION

### 1-2-1. Self-diagnosis Function

When problems occur while the unit is operating, the self-diagnosis function starts working, and displays on the LCD screen what to do.

Details of the self-diagnosis functions are provided in the Instruction manual.

### 1-2-2. Self-diagnosis Display

When problems occur while the unit is operating, the LCD screen shows a 4-digit display consisting of an alphabet and numbers, which blinks at 3.2 Hz. This 5-character display indicates the "repaired by:", "block" in which the problem occurred, and "detailed code" of the problem.

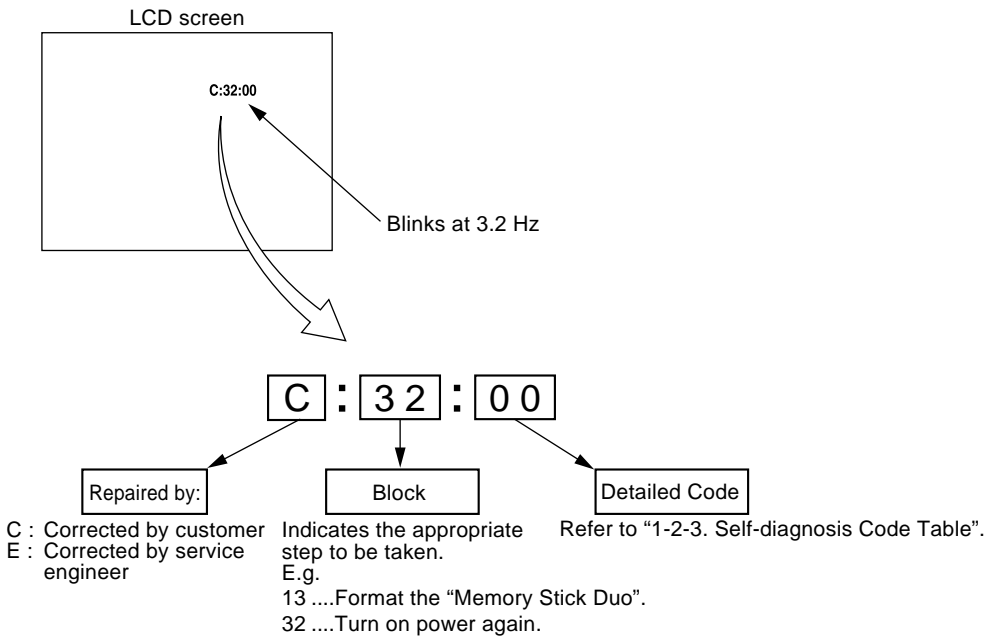

### 1-2-3. Self-diagnosis Code Table

Self-diagnosis Code				Symptom/State	Correction
Repaired by:	Block Function	Detailed Code			
C	1 3	0 1	The internal memory has experienced a format error.	Format the internal memory.	
			“Memory Stick Duo” is unformatted.	Format the “Memory Stick Duo”.	
			“Memory Stick Duo” is broken.	Insert a new “Memory Stick Duo”.	
			“Memory Stick Duo” type error	Insert a supported “Memory Stick Duo”.	
			The camera cannot read or write data on the “Memory Stick Duo”.	Turn the power off and on again, or taking out and inserting the “Memory Stick Duo” several times.	
C	3 2	0 1	Trouble with hardware	Turn the power off and on again.	
E	6 1	0 0	Difficult to adjust focus (Cannot initialize focus)	Retry turn the power on by the power switch. If it does not recover, check the focus reset sensor of lens block (pin ② of CN402 on the SY-169 board). If it is OK, check the focus motor drive IC (IC401 on the SY-169 board).	
E	6 1	1 0	Zoom operations fault (Cannot initialize zoom lens.)	Retry turn the power on by the power switch. Check the zoom reset sensor of lens block (pin ④ of CN402 on the SY-169 board) when zooming is performed when the zoom button is operated. If it is OK, check the zoom motor drive IC (IC401 on the SY-169 board).	
E	6 2	0 2	Abnormality of IC for steadyspot.	Check or replacement of the IC for steadyspot (IC503 on the SY-169 board).	
E	6 2	1 0	Lens initializing failure.	Check or replacement of the IC for steadyspot (IC503 on the SY-169 board).	
E	6 2	1 1	Lens overheating (PITCH).	Check the HALL element (PITCH) of optical image stabilizer (pin ⑤, ⑥ of CN402 on the SY-169 board). If it is OK, check PITCH angular velocity sensor (SE502 on the SY-169 board) peripheral circuits.	
E	6 2	1 2	Lens overheating (YAW).	Check the HALL element (YAW) of optical image stabilizer (pin ⑱, ⑳ of CN402 on the SY-169 board). If it is OK, check YAW angular velocity sensor (SE501 on the SY-169 board) peripheral circuits.	
E	6 2	2 0	Abnormality of thermistor.	Check the OIS temp sensor of optical image stabilizer (pin ④ of CN402 on the SY-169 board).	
E	9 1	0 1	Abnormality when flash is being charged.	Checking of flash unit or replacement of flash unit. (Note)	
E	9 2	0 0	Non-standard battery is used.	Use the compatible battery only.	

**Note:** After repair, be sure to perform “1-3. PROCESS AFTER FIXING FLASH ERROR”.

### 1-3. PROCESS AFTER FIXING FLASH ERROR

When “FLASH error” (Self-diagnosis Code E : 91 : 01) occurs, to prevent any abnormal situation caused by high voltage, setting of the flash is changed automatically to disabling charge and flash setting.

After fixing, this setting needs to be deactivated. Flash error code can be initialized by the operations on the HOME screen.

#### Method for Initializing the Flash Error Code

##### Initialize

Initializes the setting to the default setting. Even if you execute this function, the images stored in the internal memory are retained.

- ① Select [Initialize] with ▲/▼/◀/▶, then press ●.  
The message “Initialize all settings” appears.
- ② Select [OK] with ▲, then press ●.  
The settings are reset to the default setting.

#### To cancel the resetting

Select [Cancel] in step ②, then press ●.

- Make sure that the power is not disconnected during resetting.

## 1-4. METHOD FOR COPYING OR ERASING THE DATA IN INTERNAL MEMORY

The data can be copied/erased by the operations on the HOME screen. (When erasing the data, execute formatting the internal memory.)

**Note 1:** When replacing the SY-169 board, erase the data in internal memory of the board before replacement.

**Note 2:** When replacing the SY-169 board, execute formatting and initialize the internal memory after replacement.

### Method for Copying the Data in Internal Memory

#### Copy

Copies all images in the internal memory to a "Memory Stick Duo".

- ① Insert a "Memory Stick Duo" having 32 MB or larger capacity.
- ② Select [Copy] with ▲/▼/◀/▶ on the control button, then press ●.  
The message "All data in internal memory will be copied" appears.
- ③ Select [OK] with ▲, then press ●.  
Copying starts.

#### To cancel the copying

Select [Cancel] in step ③, then press ●.

- Use a fully charged battery pack. If you attempt to copy image files using a battery pack with little remaining charge, the battery pack may run out, causing copying to fail or possibly corrupting the data.
- You cannot copy individual images.
- The original images in the internal memory are retained even after copying. To delete the contents of the internal memory, remove the "Memory Stick Duo" after copying, then execute the [Format] command in [Internal Memory Tool].
- When you copy the data in the internal memory to the "Memory Stick Duo", all the data will be copied. You cannot choose a specific folder on the "Memory Stick Duo" as the destination for the data to be copied.
- Even if you copy data, a **DPOF** (Print order) mark is not copied

### Method for Formatting the Internal Memory

This item does not appear when a "Memory Stick Duo" is inserted in the camera.

#### Format

Formats the internal memory.

- Note that formatting irrevocably erases all data in the internal memory, including even protected images.

- ① Select [Format] with ▲/▼/◀/▶ on the control button, then press ●.  
The message "All data in internal memory will be erased" appears.
- ② Select [OK] with ▲, then press ●.  
The format is completed.

#### To cancel the formatting

Select [Cancel] in step ②, then press ●.

## 1-5. HOW TO WRITE DATA TO INTERNAL MEMORY

Usually, the camera has been set so as to disable the data writing from the PC to the internal memory of the camera. This setting must be changed temporarily when the data is to be written to the internal memory such as a case after the board replacement. To change the setting, use the write enable tool "WriteEnableTool.exe".

### Data writing method

- 1) Connect the PC to the camera (USB mode: Mass Storage), and switch the driver to the "Sony Seus USB Driver".
- 2) Start the Write Enable Tool and the SeusEX.
- 3) Click the Activate Write Enable Mode button of the Write Enable Tool.

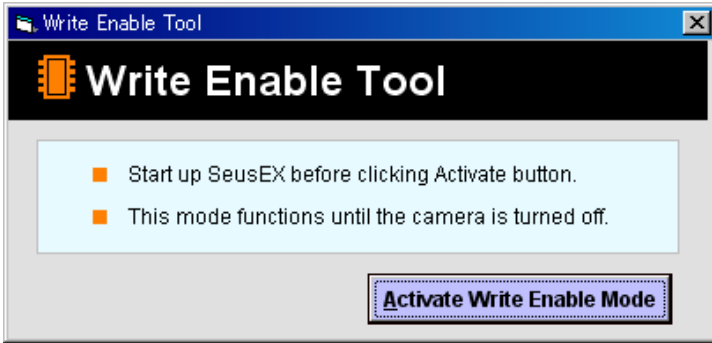

- 4) Upon completion of the setting change, the following message will be displayed.

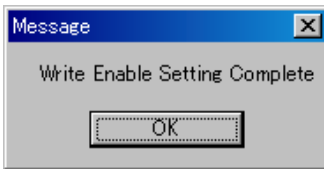

- 5) Return the driver to the original one, and connect the PC to the camera (USB mode: Mass Storage).
- 6) Write the data read out into the PC to the internal memory of the camera.
- 7) Disconnect the PC from the camera, and turn off the camera.

**Note:** By turning off the camera, the write enable setting is reset.

## 2. DISASSEMBLY

### NOTE FOR REPAIR

- Make sure that the flat cable and flexible board are not cracked or bent at the terminal.  
Do not insert the cable insufficiently nor crookedly.
- When remove a connector, don't pull at wire of connector. It is possible that a wire is snapped.
- When installing a connector, don't press down at wire of connector.  
It is possible that a wire is snapped.
- Do not apply excessive load to the gilded flexible board.

Cut and remove the part of gilt which comes off at the point.  
(Be careful or some pieces of gilt may be left inside)

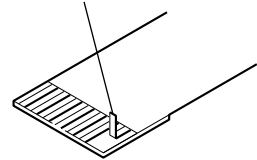

### DISCHARGING OF THE ST-160 BOARD'S CHARGING CAPACITOR (C901)

The charging capacitor (C901) of the ST-160 board is charged up to the maximum 300 V potential.

There is a danger of electric shock by this high voltage when the capacitor is handled by hand. The electric shock is caused by the charged voltage which is kept without discharging when the main power of the unit is simply turned off. Therefore, the remaining voltage must be discharged as described below.

#### Preparing the Short Jig

To preparing the short jig, a small clip is attached to each end of a resistor of 1 k $\Omega$  / 1 W (1-215-869-11).

Wrap insulating tape fully around the leads of the resistor to prevent electrical shock.

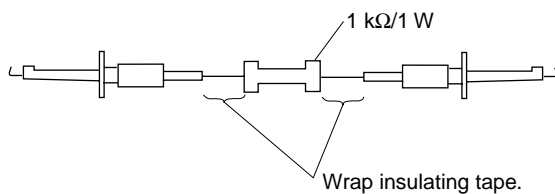

**Note: High-voltage cautions**

#### Discharging the Capacitor

Short-circuit between the two points with the short jig about 10 seconds.

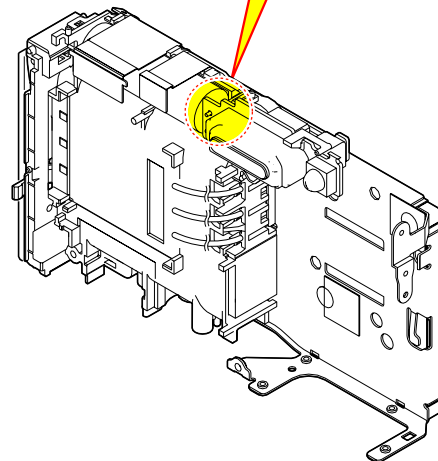
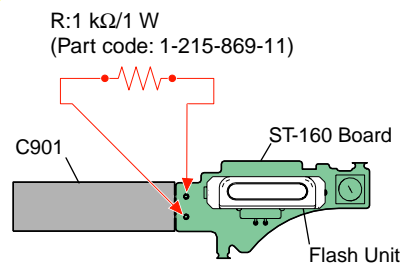

## 2-1. IDENTIFYING PARTS

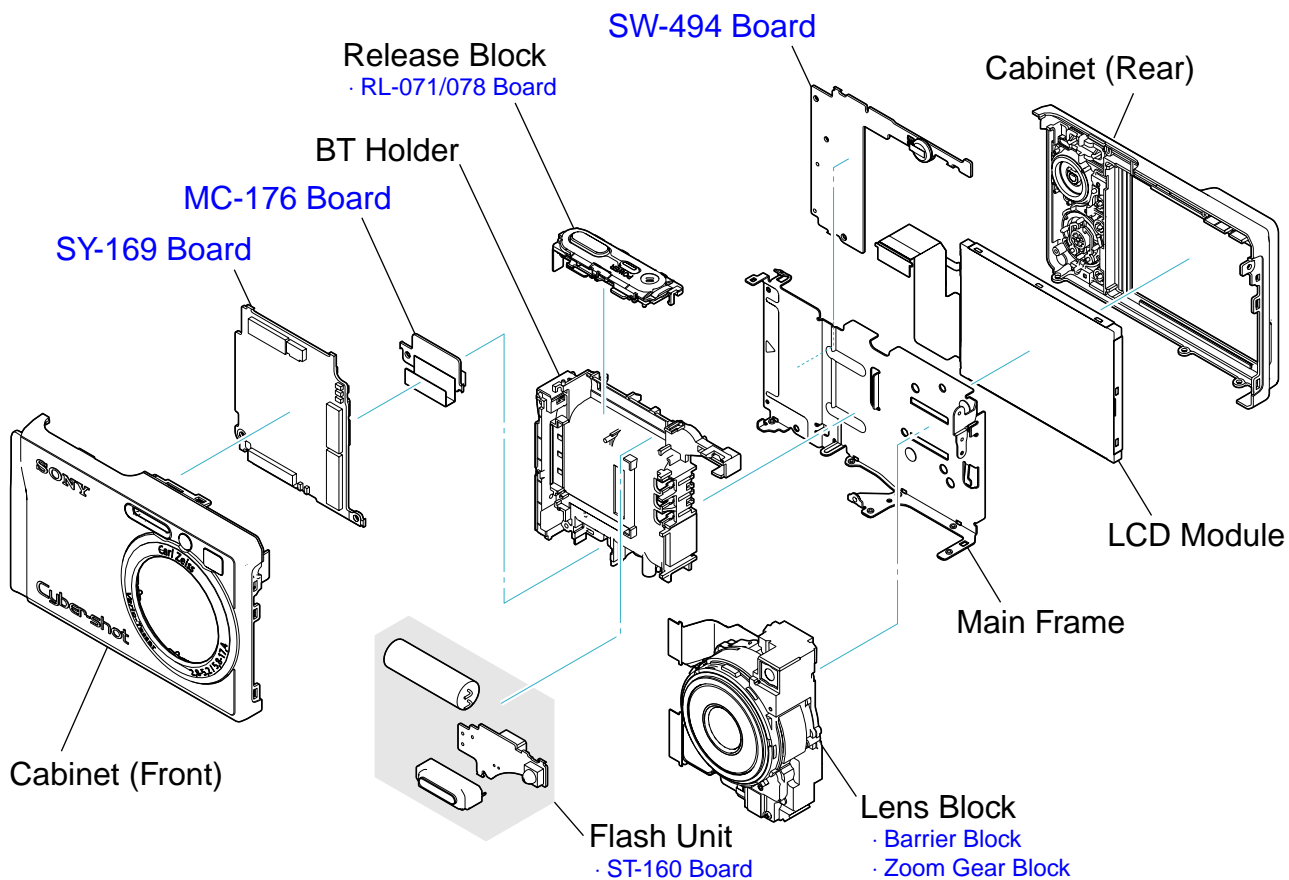

### - DISASSEMBLY FLOW -

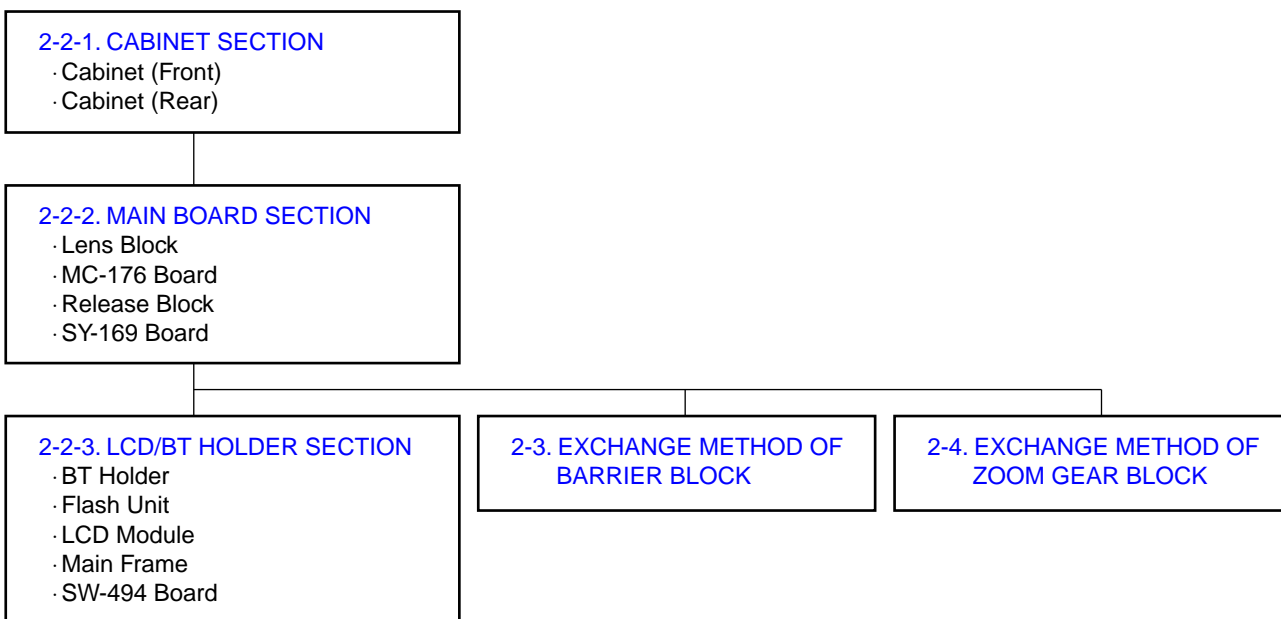

## 2-2. DISASSEMBLY

EXPLODED VIEW

HARDWARE LIST

### 2-2-1. CABINET SECTION

Follow the disassembly in the numerical order given.

- ① Cabinet (Front) (①-1 to ①-8)
- ② Cabinet (Rear) (②-1 to ②-2)

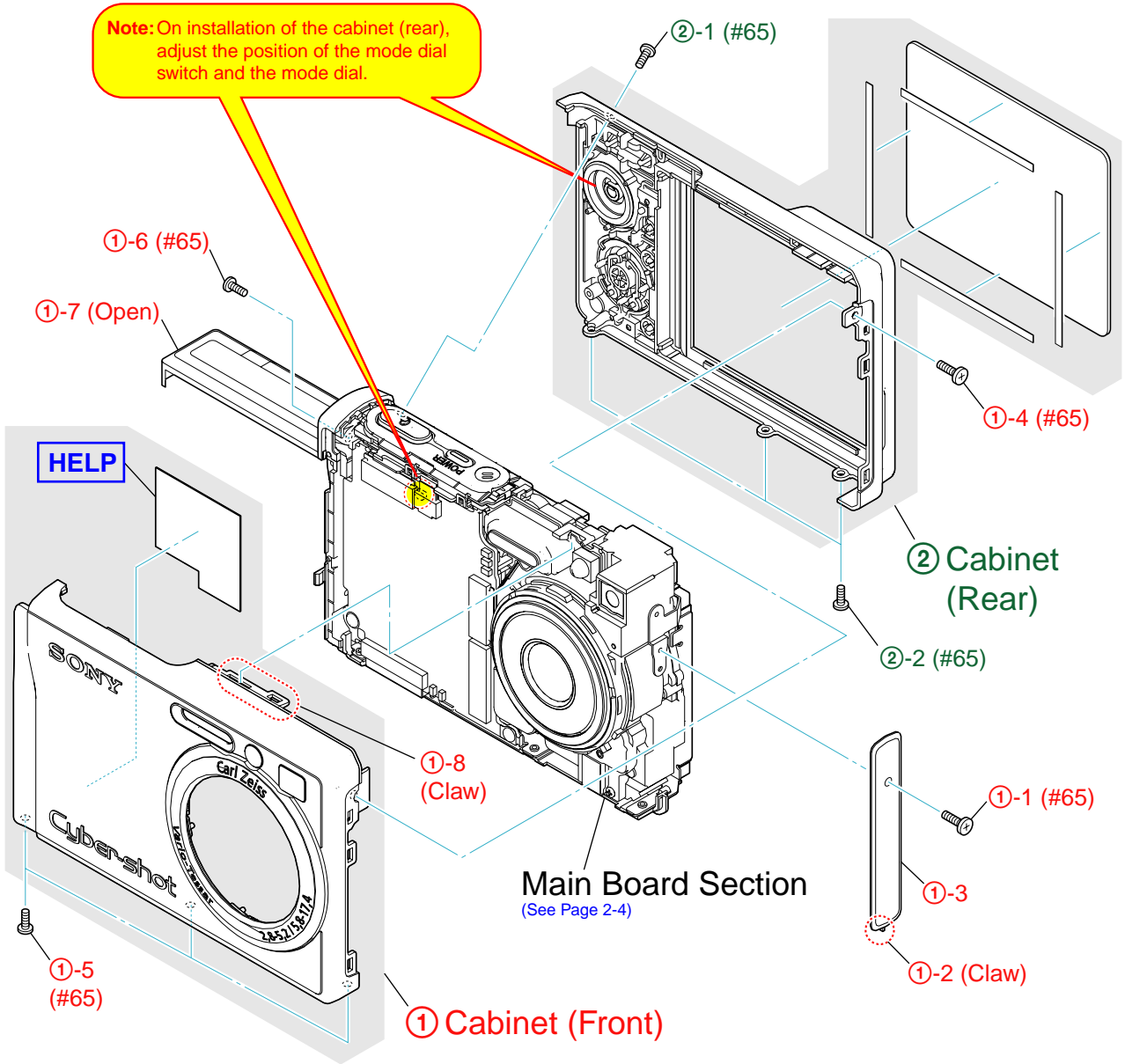

## 2-2-2. MAIN BOARD SECTION

Follow the disassembly in the numerical order given.

- ① Release Block (①-1 to ①-3)
- ② Lens Block (②-1 to ②-5)
- ③ SY-169 Board (③-1 to ③-11)

EXPLODED VIEW

HARDWARE LIST

**Note:** High-voltage cautions

### Discharging the Capacitor

Short-circuit between the two points with the short jig about 10 seconds.

R: 1 kΩ/1 W  
(Part code: 1-215-869-11)

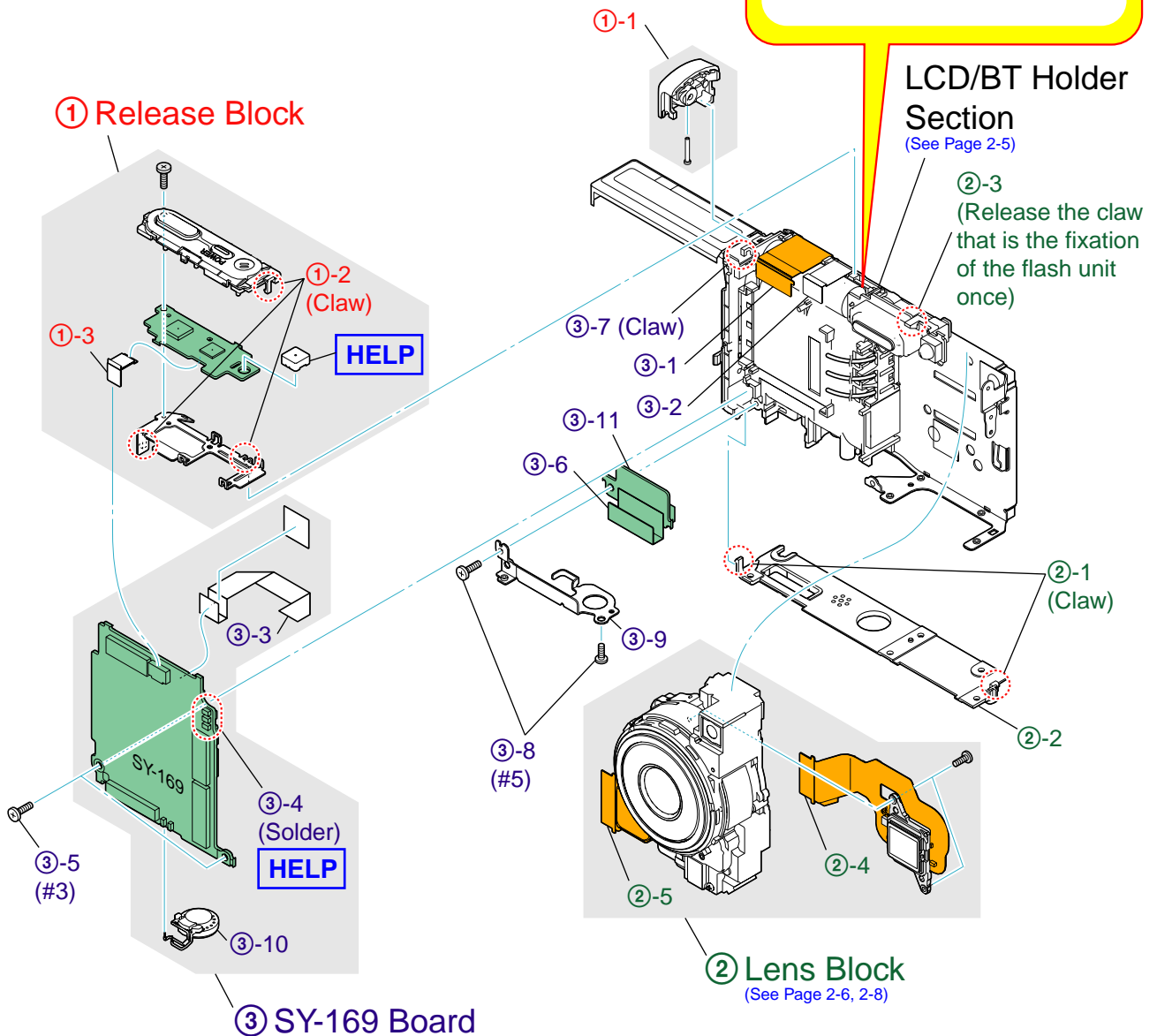
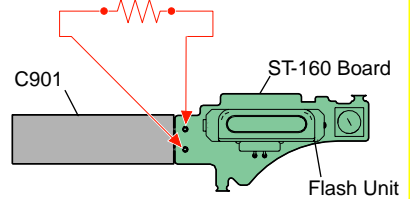

### 2-2-3. LCD/BT HOLDER SECTION

Follow the disassembly in the numerical order given.

- ① Flash Unit (①-1)
- ② LCD Panel/SW-494 Board (②-1 to ②-4)
- ③ BT Holder (③-1 to ③-3)

EXPLODED VIEW

HARDWARE LIST

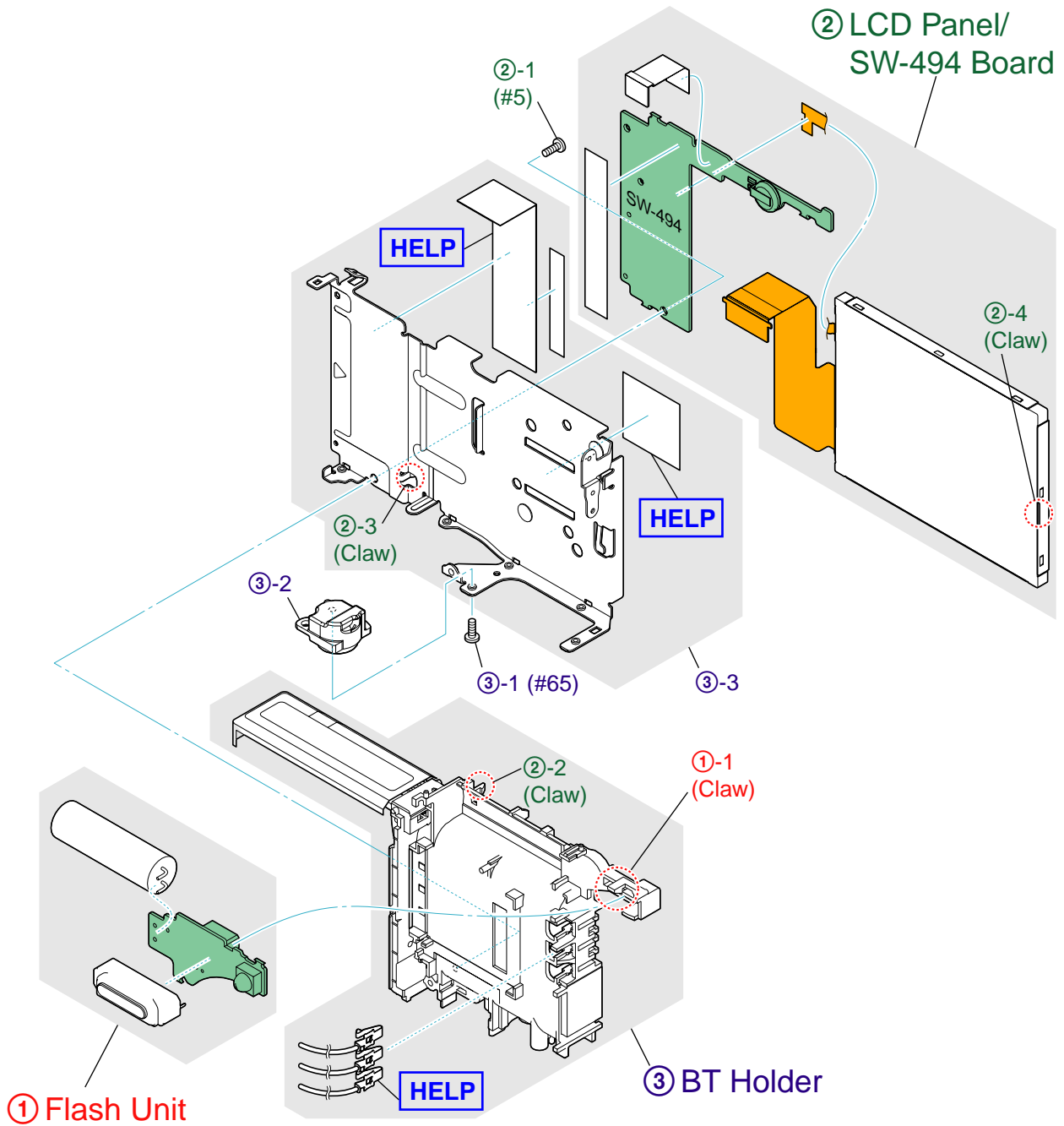

## 2-3. EXCHANGE METHOD OF BARRIER BLOCK

**Note:** Do not hold the part of spring.

### 2-3-1. HOW TO REMOVE THE ORNAMENTAL RING (A)

- ① Turn on the power switch.
- ② With the ornamental ring (A) extended, remove the battery forcibly.
- ③ Apply a solvent to the tweezers or a needle, and dissolve the adhesive on the barrier tapes that secure the ornamental ring (A) to the barrier block.
- ④ Rotate the ornamental ring (A) clockwise to remove.

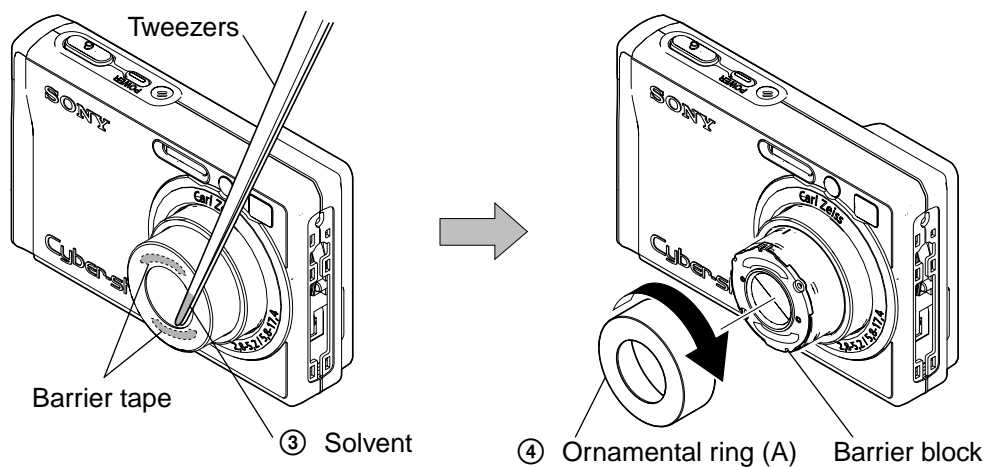

### 2-3-2. HOW TO REMOVE THE BARRIER BLOCK

- ① Remove two screws.
- ② Remove the barrier block and the inner ring.

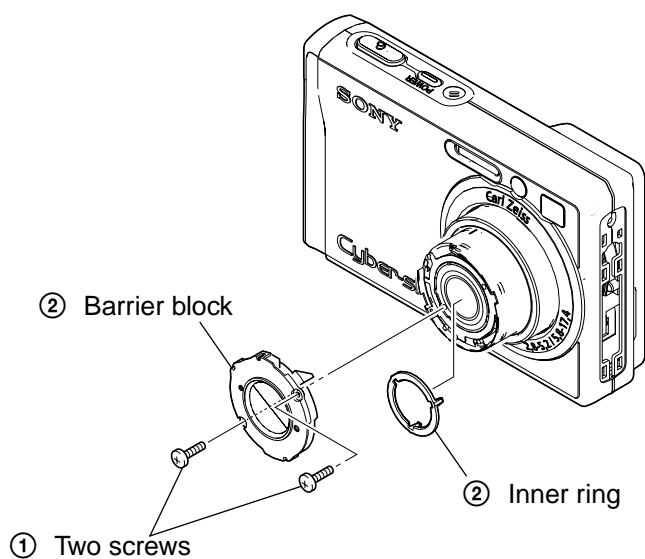

### 2-3-3. HOW TO INSTALL THE BARRIER BLOCK

- ① Install the inner ring and the barrier block.

**Note:** When installing the barrier block, the CAV No. must be located in the lower left position.

- ② Secure the barrier block with two screws.

\* Tightening torque =  $0.049 \pm 0.01N \cdot m$  ( $0.5 \pm 0.1kgf \cdot cm$ )

**Note:** Check that the barrier feather of the barrier block is not opened slightly or half-closed.

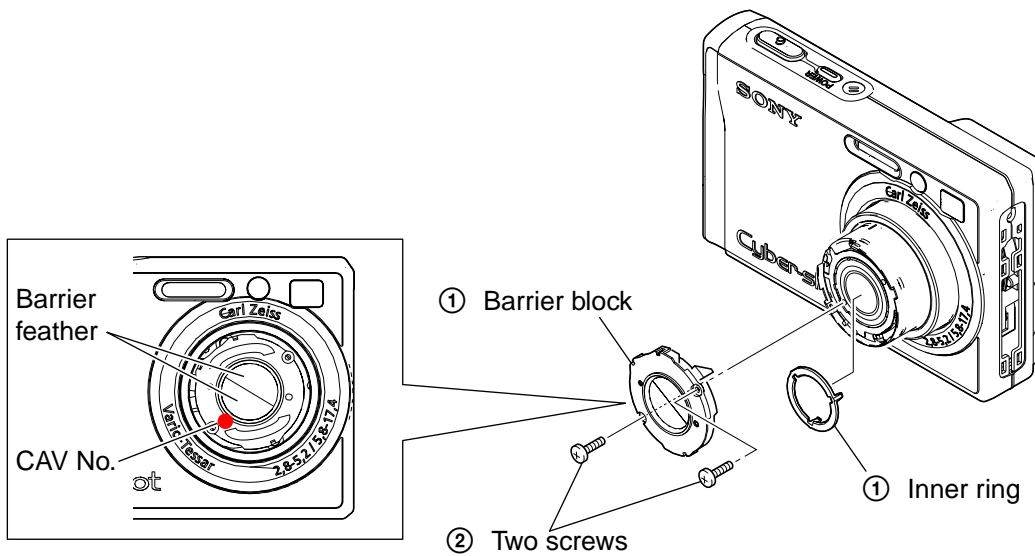

### 2-3-4. HOW TO INSTALL THE ORNAMENTAL RING (A)

- ① Affix two barrier tapes to the barrier block.

**Note:** The barrier tape must not cover the boss of the barrier block.

- ② Install the ornamental ring (A).

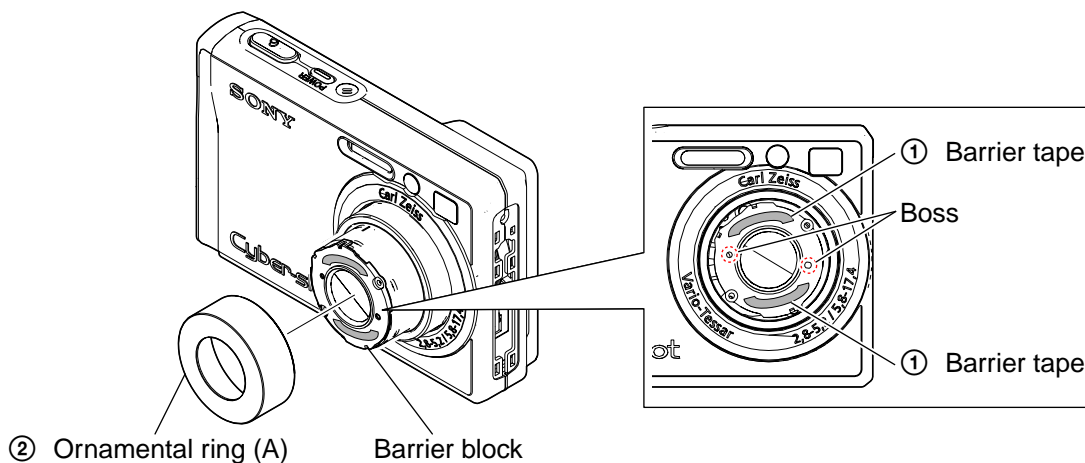

**Note:** Turn on and off the power to check the opening and closing of the barrier block with the camera in horizontal, up and down directions respectively.

Further, check the zoom motion.

Rotate the ornamental ring (A) lightly to check that it is not removed.

## 2-4. EXCHANGE METHOD OF ZOOM GEAR BLOCK

**Note:** Do not hold the part of terminal and the part of spring.

### 2-4-1. HOW TO REMOVE THE ZOOM GEAR BLOCK

- **HOW TO REMOVE THE REAR ASSEMBLY**

- ① Remove the screw, and then the OVF.

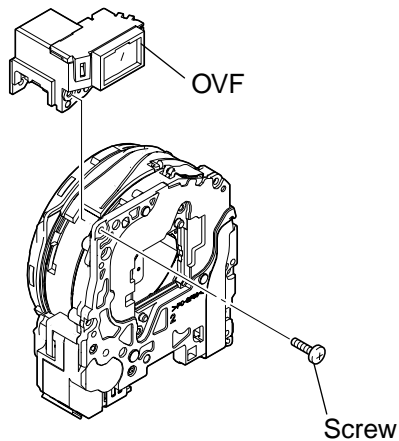

- ② Remove the shutter flexible board from the connector.
  - ③ Remove the vibration-proof flexible board from the connector.
  - ④ Peel the adhesive sheet that secures the vibration-proof flexible board.
- \* When peeling the adhesive sheet, turn it over from the opposite side of the hook.

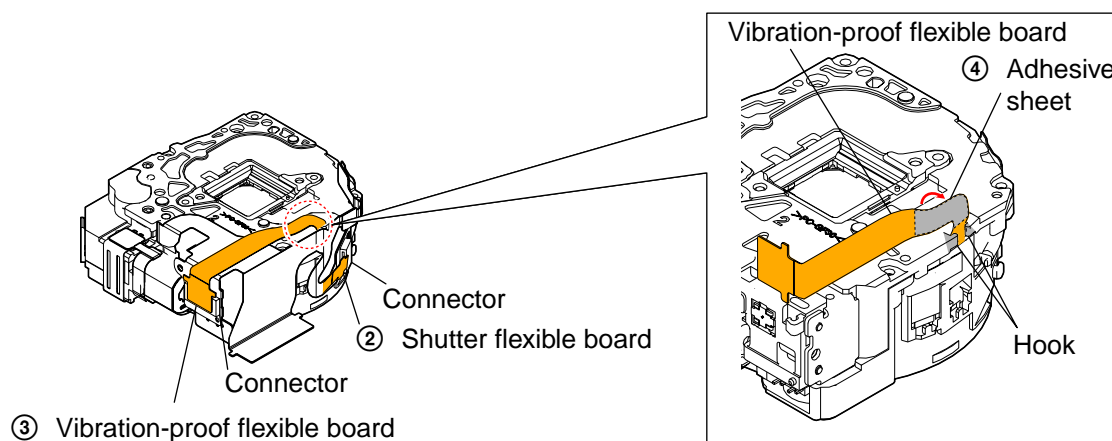

- ⑤ Peel the adhesive sheet (upper) that secures the main flexible board.
  - ⑥ Disengage the main flexible board from the hook of the ring assembly, and then slide the main flexible board to remove.
  - ⑦ Peel the adhesive sheet (lower) that secures the main flexible board.
- \* The FOCUS motor must remain soldered.

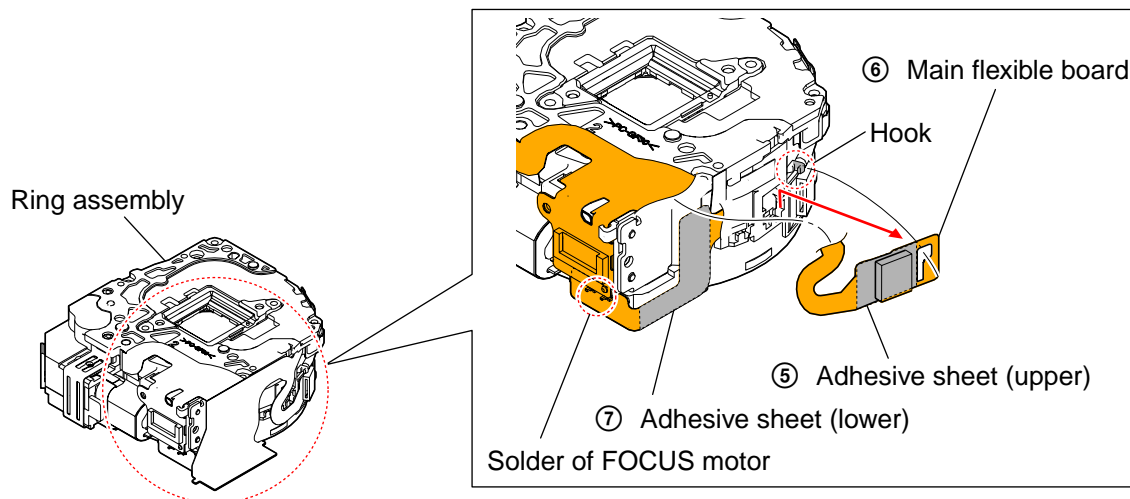

- ⑧ Remove four screws that secure the rear assembly.
  - ⑨ Remove the rear assembly, disengaging the bosses at four places.
- \* Take care not to get stuck with the vibration-proof flexible board.
- ⑩ Unhook the Z leaf spring to remove.
  - ⑪ Remove the main flexible board from the ring assembly, and remove the rear assembly and the nuruto gear.

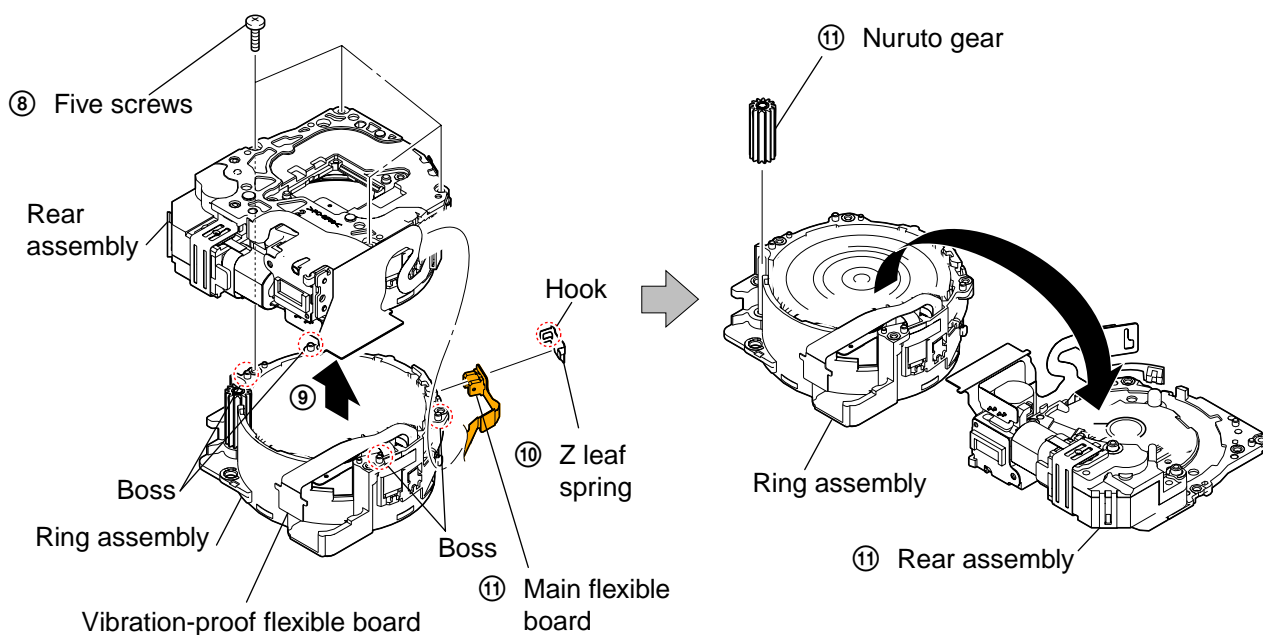

- **HOW TO REMOVE THE ZOOM GEAR BLOCK**

- ① Unsolder the zoom motor.
- ② Remove the FG leaf spring.
- ③ Remove the main flexible board from the zoom gear block.
- ④ Remove the zoom gear block.

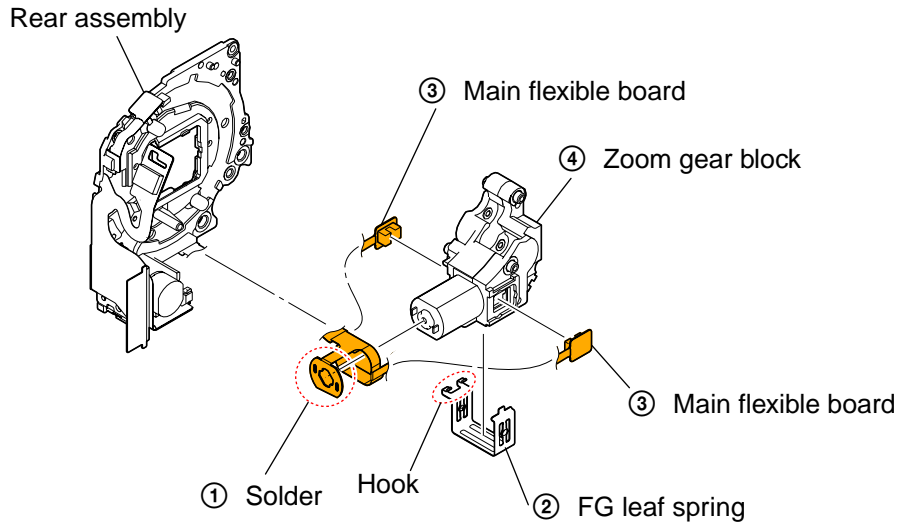

## 2-4-2. HOW TO INSTALL THE ZOOM GEAR BLOCK

- **HOW TO INSTALL THE ZOOM GEAR BLOCK**

- ① Solder the main flexible board to the zoom gear block.
- ② Install the main flexible board to the zoom gear block.
- ③ Attach the FG leaf spring.

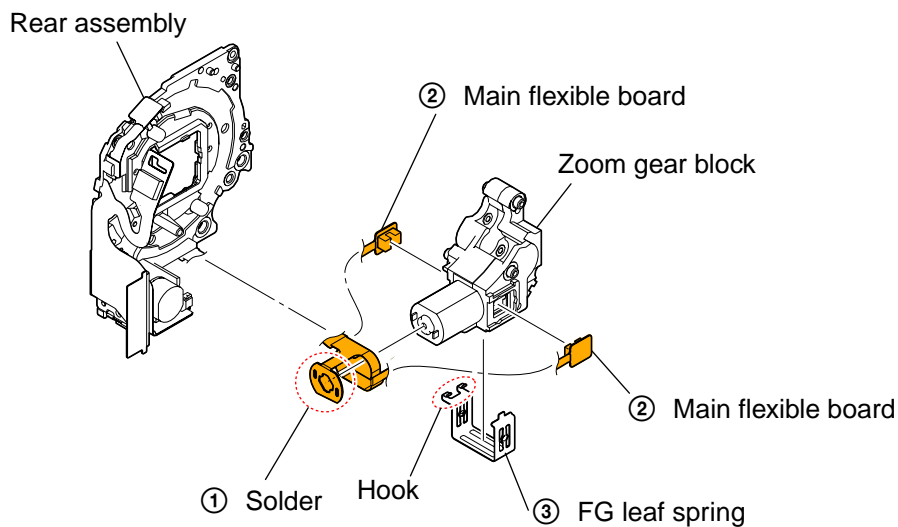

- ④ Apply the lubricant (SRX-4339) to the nuruto gear, and insert it into the ring assembly.  
 \* Rotate the gear in the ring assembly in the arrow direction until the end of the gear is not engaged with a concave portion of the ring assembly (because a convex portion of the rear assembly enters the convex portion).

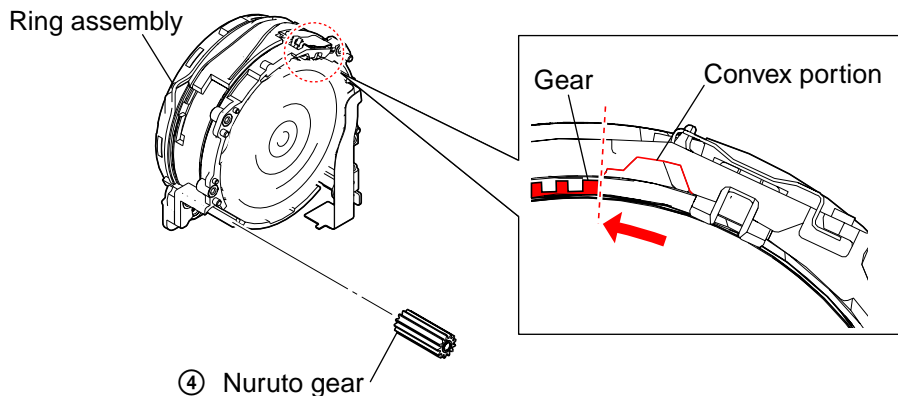

- ⑤ Install the zoom gear block on the rear assembly.  
 ⑥ Engaging four bosses, install the rear assembly on the ring assembly.  
 \* The vibration-proof flexible board must be engaged with the hook of the rear assembly.  
 ⑦ Tighten four screws in the order of ① to ④.  
 \* Tightening torque =  $0.049 \pm 0.01\text{N} \cdot \text{m}$  ( $0.5 \pm 0.1\text{kgf} \cdot \text{cm}$ )

- ⑧ Check that the projection of the nuruto shaft that protrudes from the rear assembly is within the specified value given below.  
 \* Specified value: 0.005 – 0.395mm

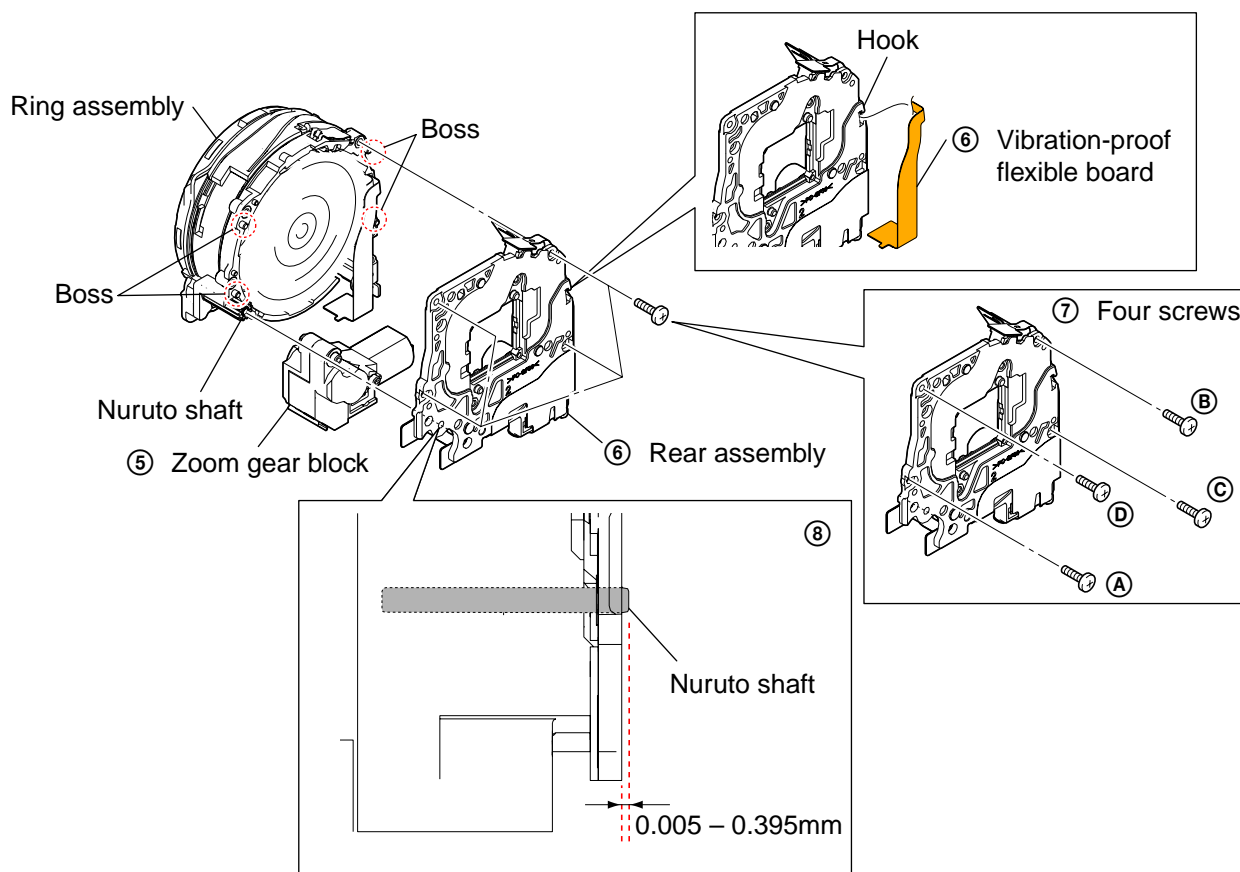

⑨ Secure and connect the main flexible board.

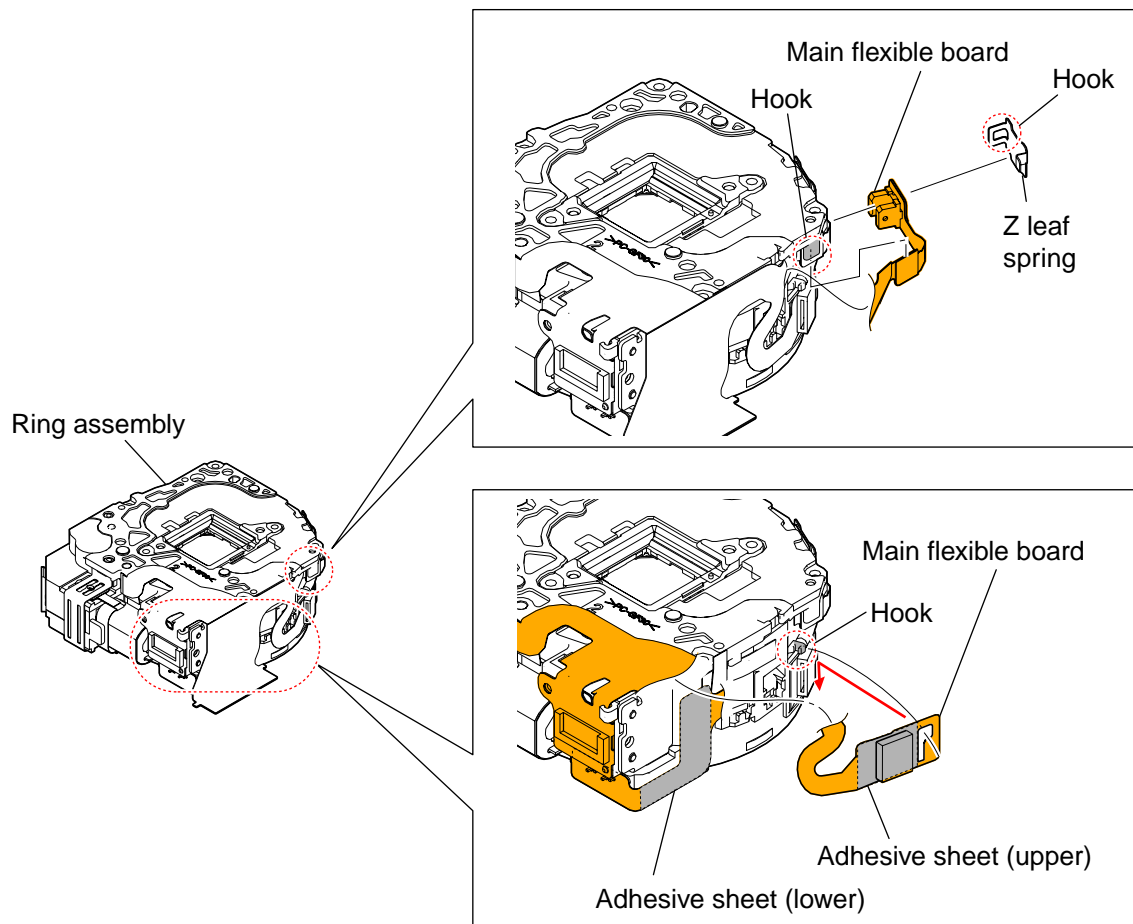

⑩ Secure and connect the vibration-proof flexible board and the shutter flexible board respectively.

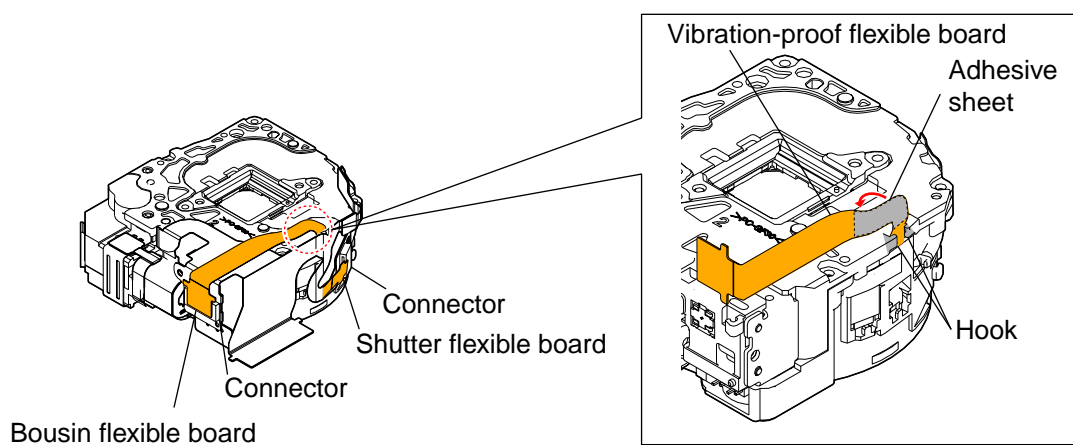

⑪ Install the OVF.

\*When installing the OVF, fit a projection of OVF in the groove of the ring assembly.

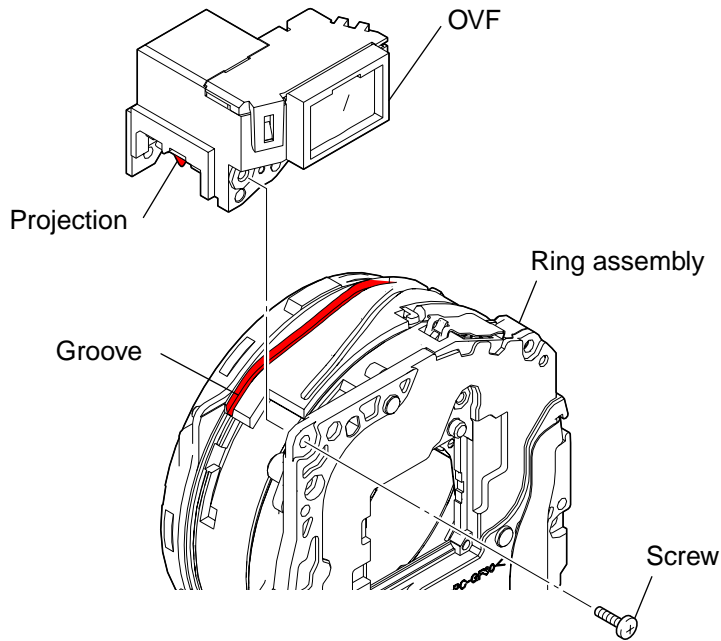

### 2-4-3. CHECK THE OPERATION

Confirm the operation after installing the lens block in the set.

- ① Power ON/OFF
- ② Expansion and contraction confirming of lens and opening and shutting confirmation of barrier.  
Confirm there are neither dirt nor wounds in the surface of the ornamental ring (A) and lens  
if there is no problem in operation.  
Wipe off when dirty.
- ③ Confirm the operation with Wide/Tele.

**Note:** Do not be of caught etc.  
Do not allophone.

# HELP

Sheet attachment positions and procedures of processing the flexible boards/harnesses are shown.

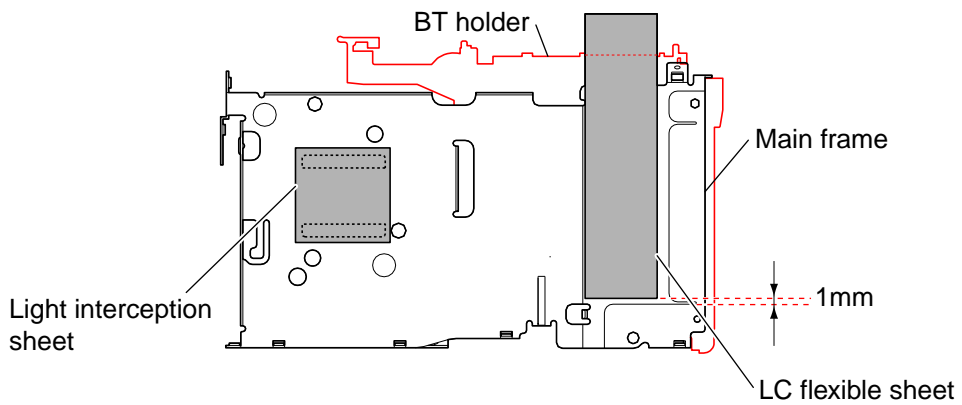
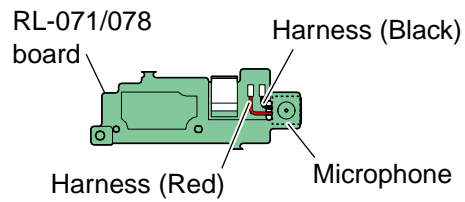
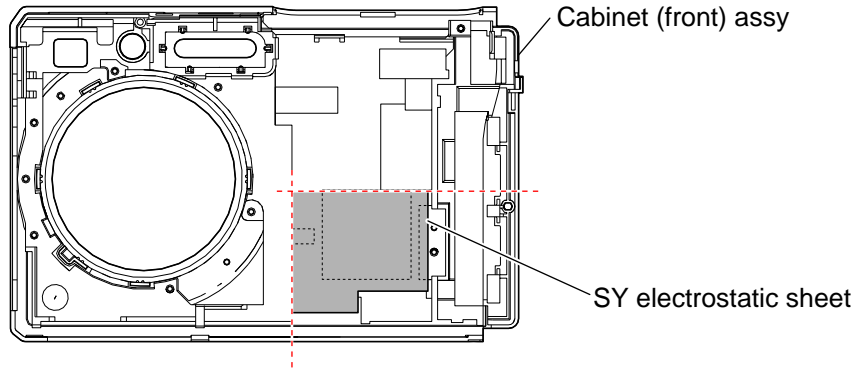

## INSTALLATION METHOD OF BATTERY TERMINAL BOARD

- ① Insert the battery terminal board into a slit in the BT holder to install.  
\* The battery terminal board is attached with the notch for installation.

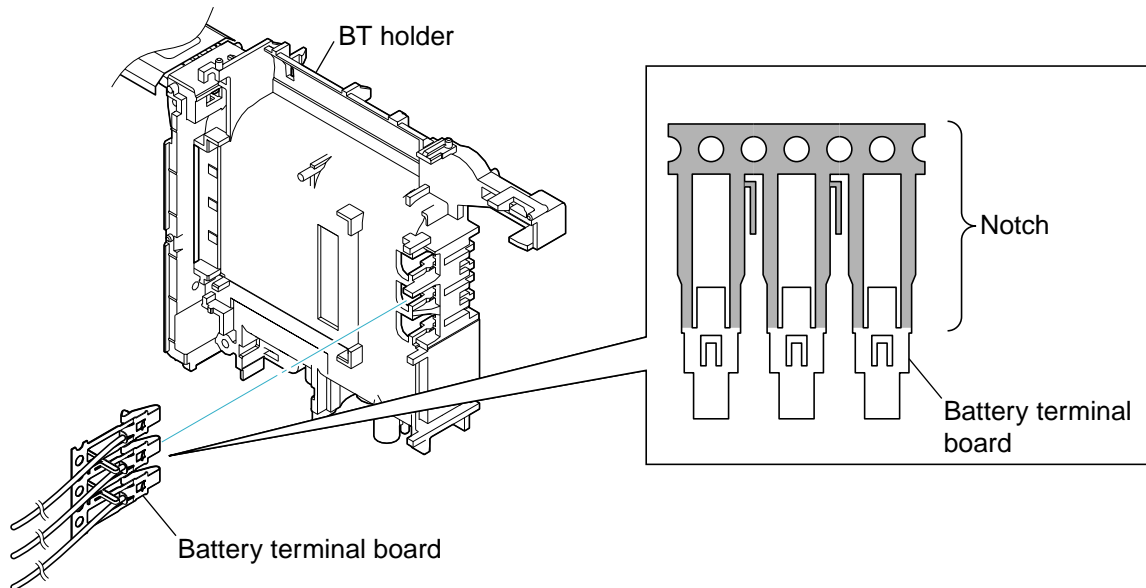

- ② Fold the notch 3 or 4 times repeatedly to break.

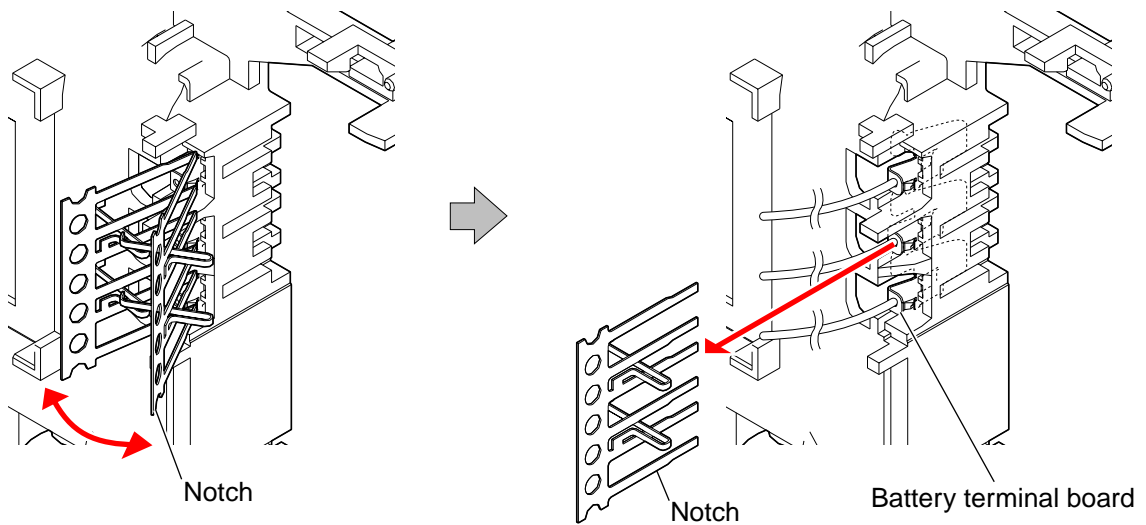

### • HARNESS ARRANGEMENT

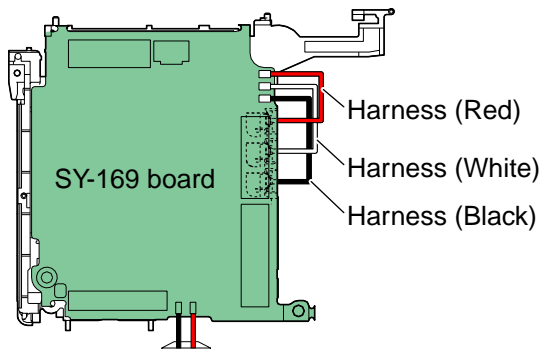

## 3. BLOCK DIAGRAMS

### Link

• [OVERALL BLOCK DIAGRAM \(1/2\)](#)

• [POWER BLOCK DIAGRAM \(1/2\)](#)

• [OVERALL BLOCK DIAGRAM \(2/2\)](#)

• [POWER BLOCK DIAGRAM \(2/2\)](#)

### 3. BLOCK DIAGRAMS

3-1. OVERALL BLOCK DIAGRAM (1/2) ( ) : Number in parenthesis ( ) indicates the division number of schematic diagram where the component is located.

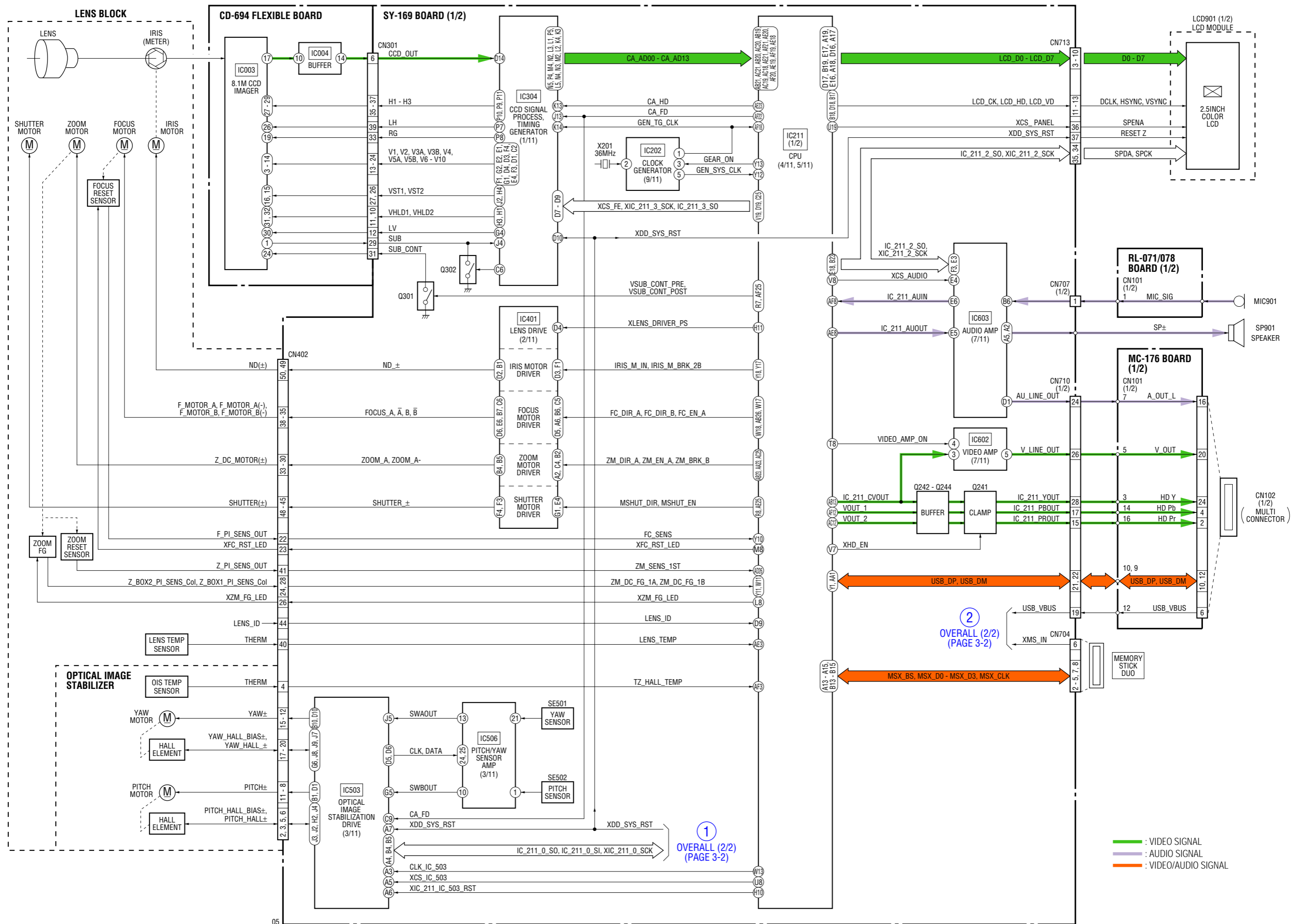

3-2. OVERALL BLOCK DIAGRAM (2/2) ( ) : Number in parenthesis ( ) indicates the division number of schematic diagram where the component is located.

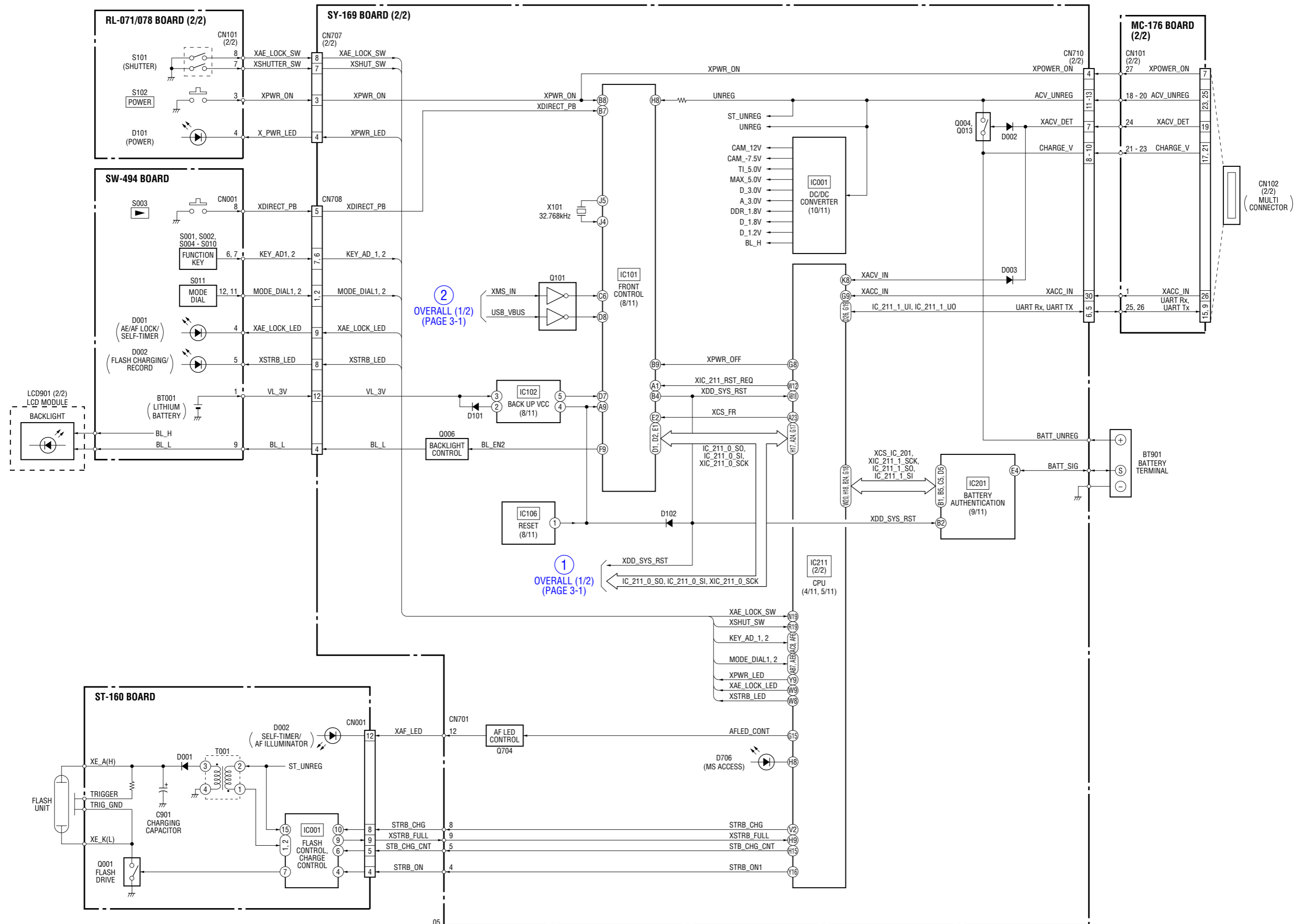

3-3. POWER BLOCK DIAGRAM (1/2) ( ) : Number in parenthesis ( ) indicates the division number of schematic diagram where the component is located.

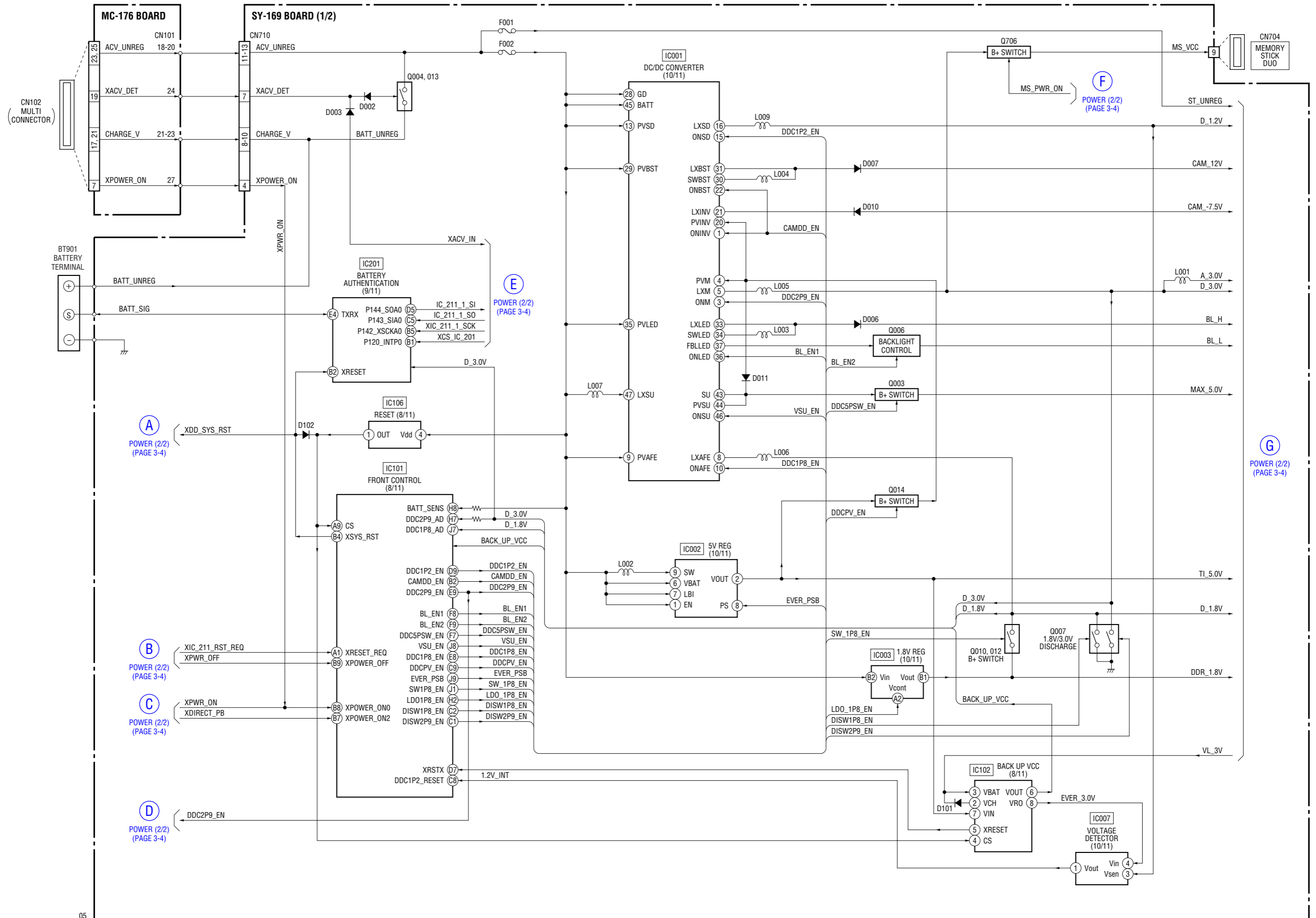

3-4. POWER BLOCK DIAGRAM (2/2) ( ) : Number in parenthesis ( ) indicates the division number of schematic diagram where the component is located.

SY-169 BOARD (2/2)

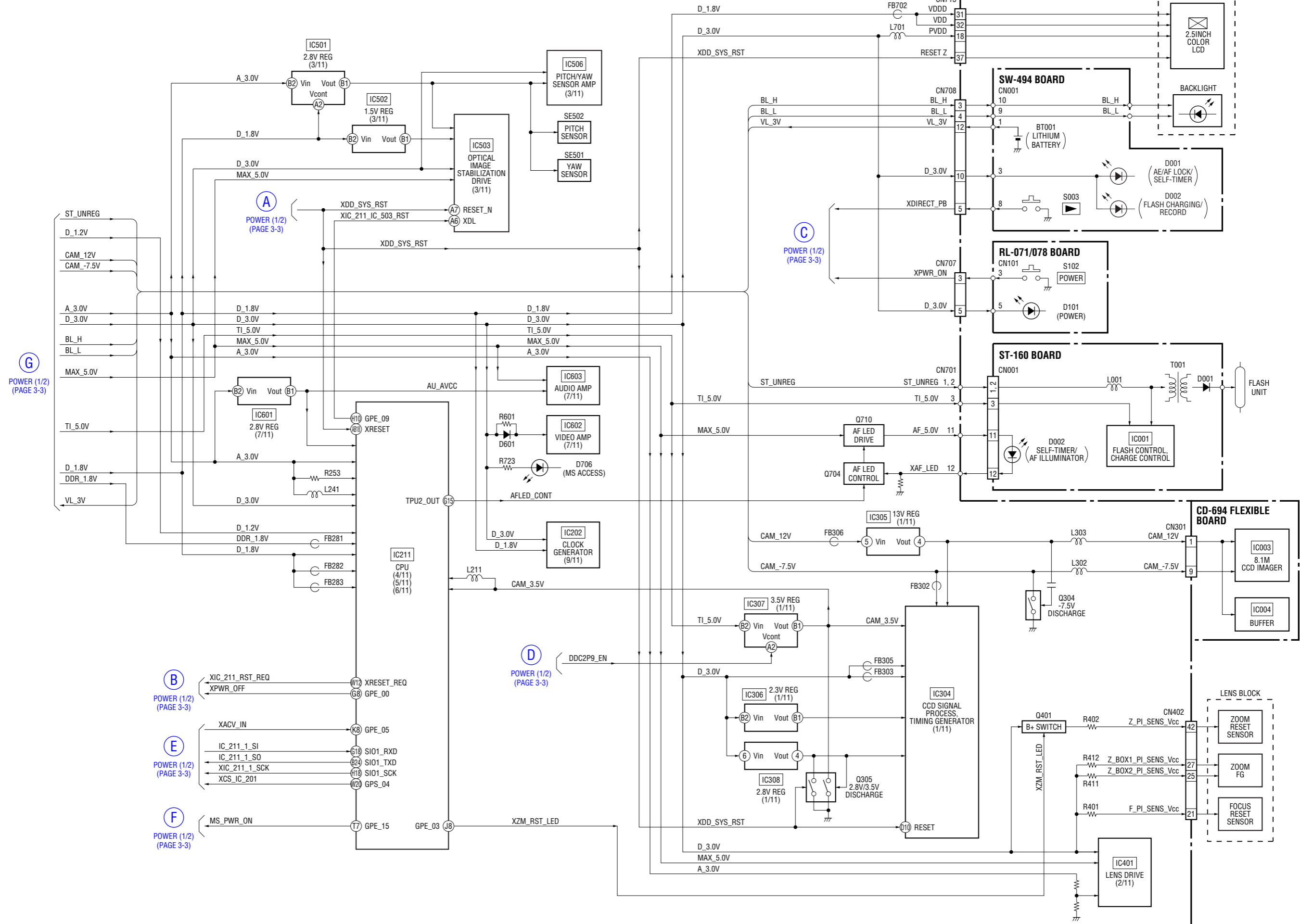

# 4. PRINTED WIRING BOARDS AND SCHEMATIC DIAGRAMS

## 4-1. FRAME SCHEMATIC DIAGRAM

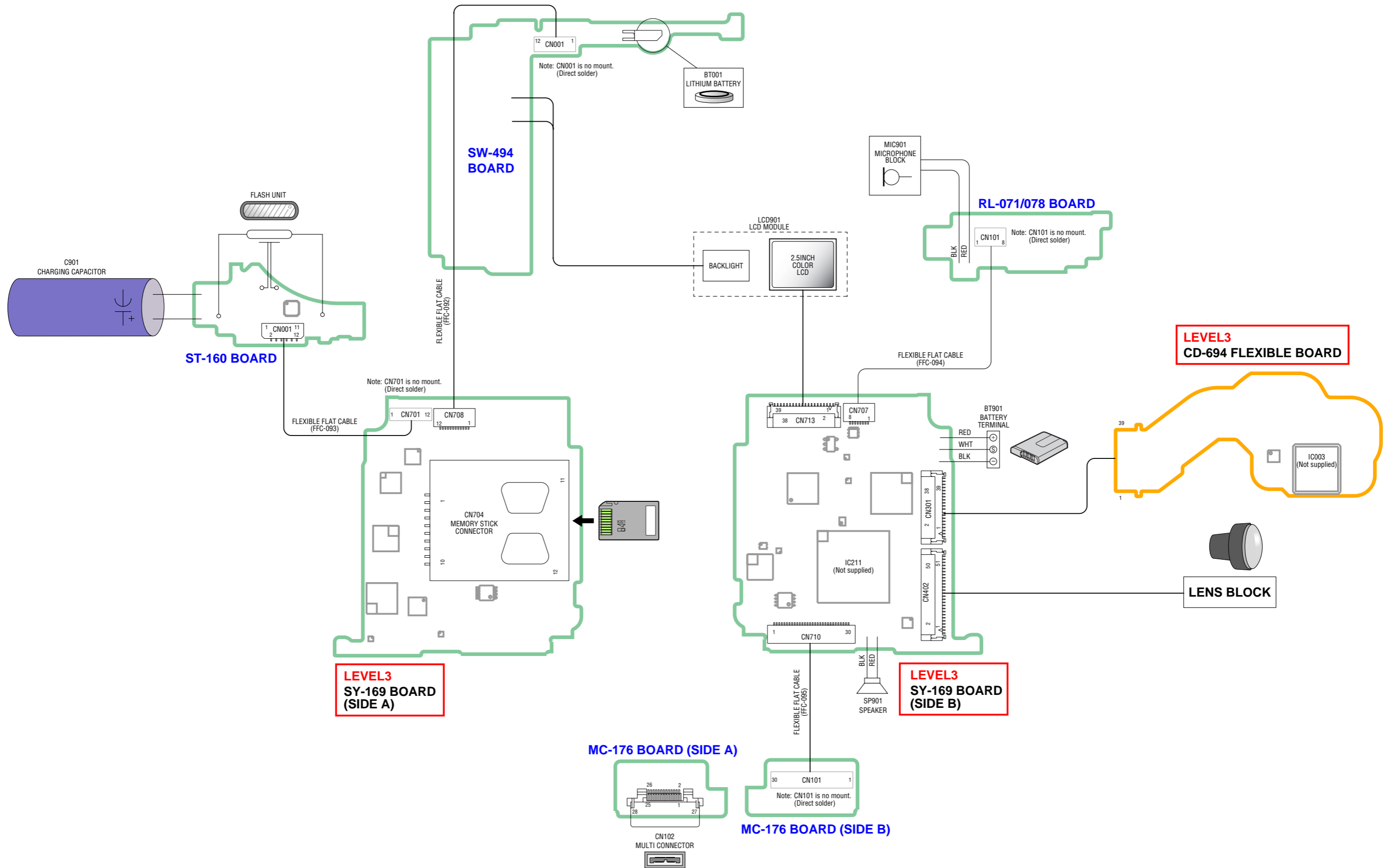

## 4-2. SCHEMATIC DIAGRAMS

### Link

- MC-176 BOARD (MULTI CONNECTOR)

- ST-160 BOARD (FLASH DRIVE)

- SW-494 BOARD (CONTROL SWITCH)

- RL-071/078 BOARD  
(CONTROL SWITCH, MIC)

- COMMON NOTE FOR SCHEMATIC DIAGRAMS

## 4-2. SCHEMATIC DIAGRAMS

### 4-2. SCHEMATIC DIAGRAMS

**THIS NOTE IS COMMON FOR SCHEMATIC DIAGRAMS**  
**(In addition to this, the necessary note is printed in each block)**

**(For schematic diagrams)**

- All capacitors are in  $\mu\text{F}$  unless otherwise noted.  $\text{pF}$  :  $\mu\text{F}$ . 50 V or less are not indicated except for electrolytics and tantalums.
- Chip resistors are 1/10 W unless otherwise noted.  $\text{k}\Omega=1000 \Omega$ ,  $\text{M}\Omega=1000 \text{k}\Omega$ .
- Caution when replacing chip parts.  
New parts must be attached after removal of chip.  
Be careful not to heat the minus side of tantalum capacitor, Because it is damaged by the heat.
- Some chip part will be indicated as follows.

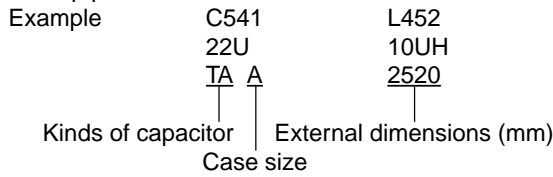

- Constants of resistors, capacitors, ICs and etc with XX indicate that they are not used.  
In such cases, the unused circuits may be indicated.
- Parts with ★ differ according to the model/destination. Refer to the mount table for each function.
- All variable and adjustable resistors have characteristic curve B, unless otherwise noted.
- Signal name  
XEDIT → EDIT      PB/XREC → PB/REC
- : non flammable resistor
- : fusible resistor
- : panel designation
- : B+ Line
- : B- Line
- : IN/OUT direction of (+,-) B LINE.
- : adjustment for repair.

**(Measuring conditions voltage and waveform)**

- Voltages and waveforms are measured between the measurement points and ground when camera shoots color bar chart of pattern box. They are reference values and reference waveforms.  
(VOM of DC 10 M $\Omega$  input impedance is used)
- Voltage values change depending upon input impedance of VOM used.)

**Precautions for Replacement of Imager**

- If the imager has been replaced, carry out all the adjustments for the camera section.
- As the imager may be damaged by static electricity from its structure, handle it carefully like for the MOS IC.  
In addition, ensure that the receiver is not covered with dusts nor exposed to strong light.

**1. Connection**

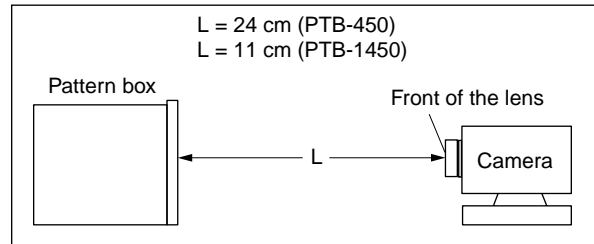
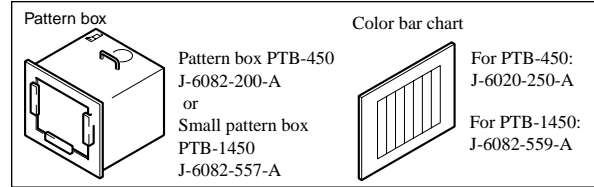

**2. Adjust the distance so that the output waveform of Fig. a and the Fig. b can be obtain.**

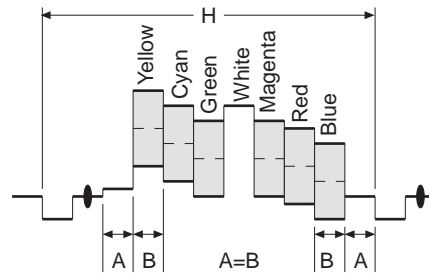

Fig. a (Video output terminal output waveform)

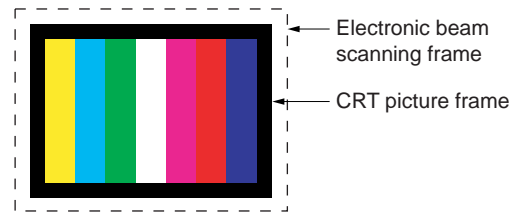

Fig.b (Picture on monitor TV)

When indicating parts by reference number, please include the board name.

The components identified by mark  $\triangle$  or dotted line with mark  $\triangle$  are critical for safety.  
Replace only with part number specified.

Les composants identifiés par une marque  $\triangle$  sont critiques pour la sécurité.  
Ne les remplacer que par une pièce portant le numéro spécifié.

Schematic diagrams of the CD-694 flexible board and SY-169 board are not shown.  
Pages from 4-3 to 4-14 are not shown.

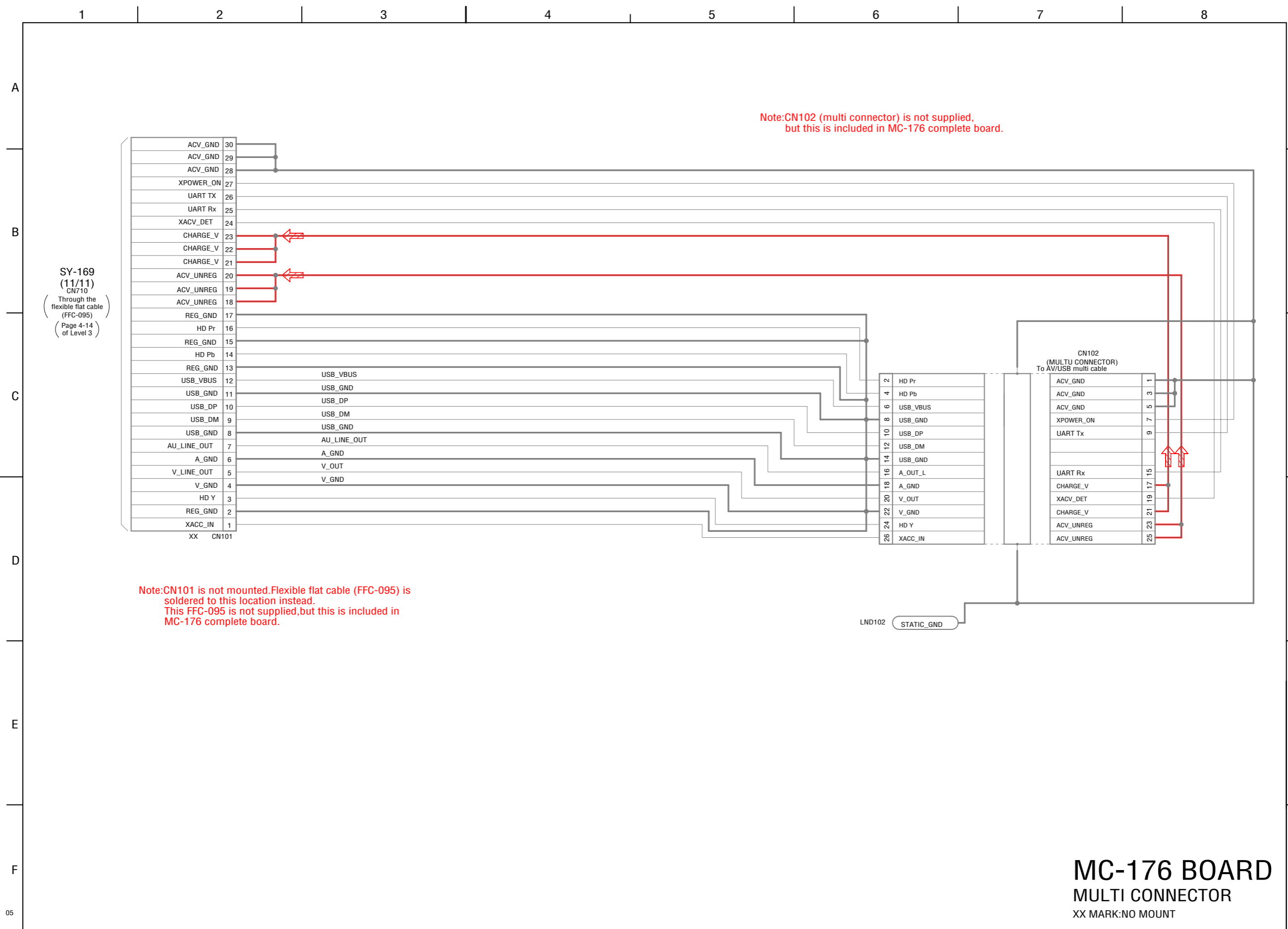

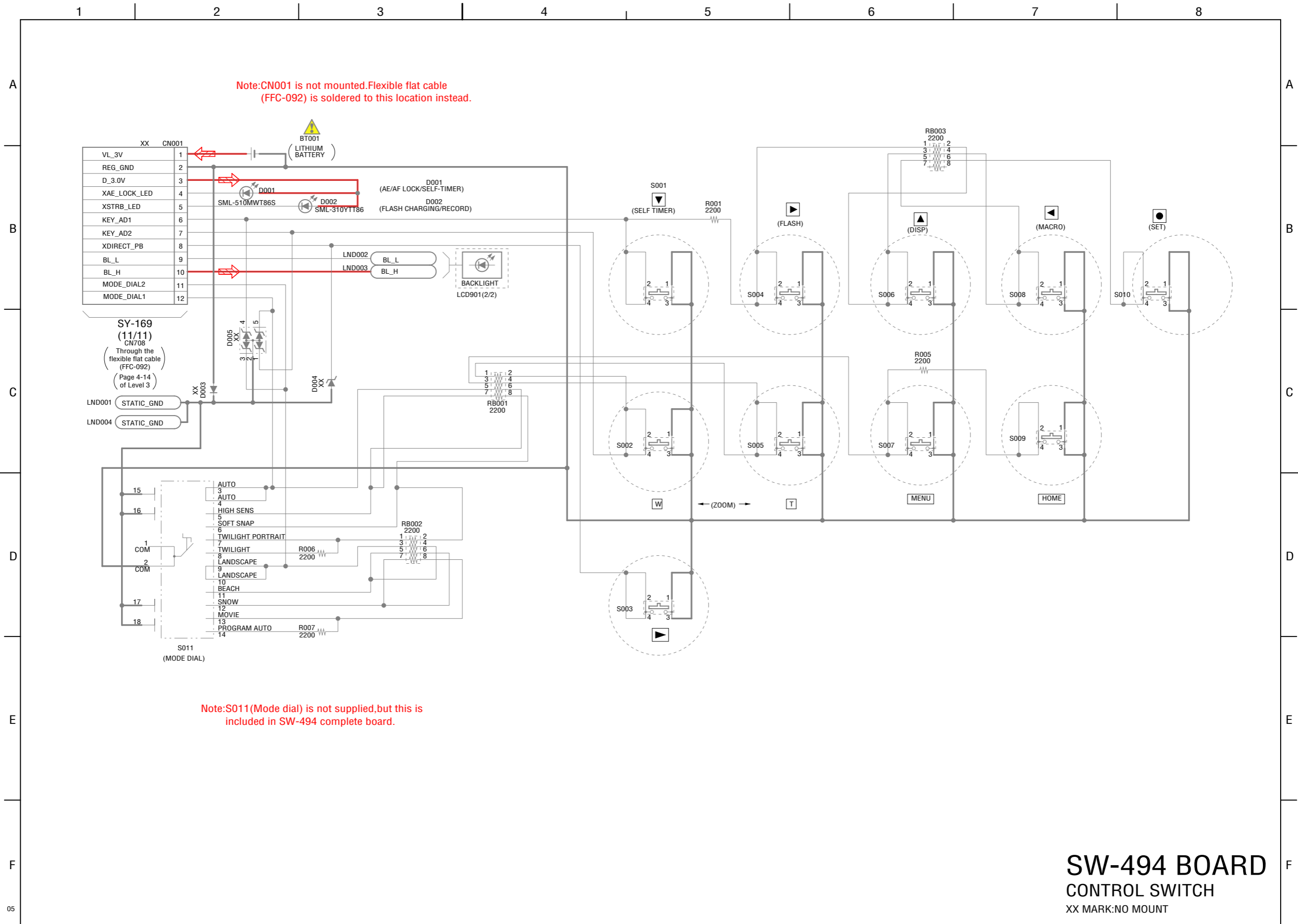

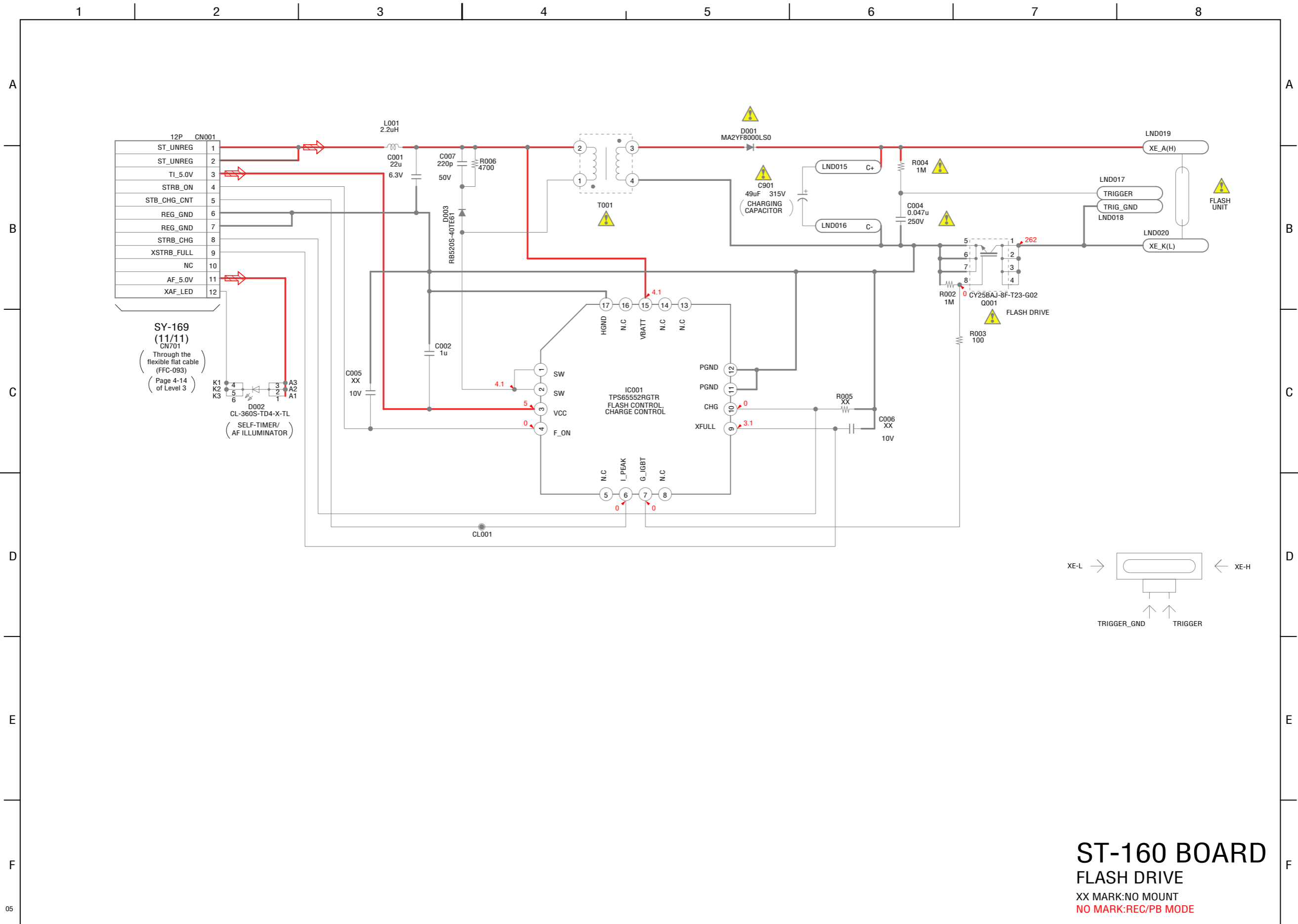

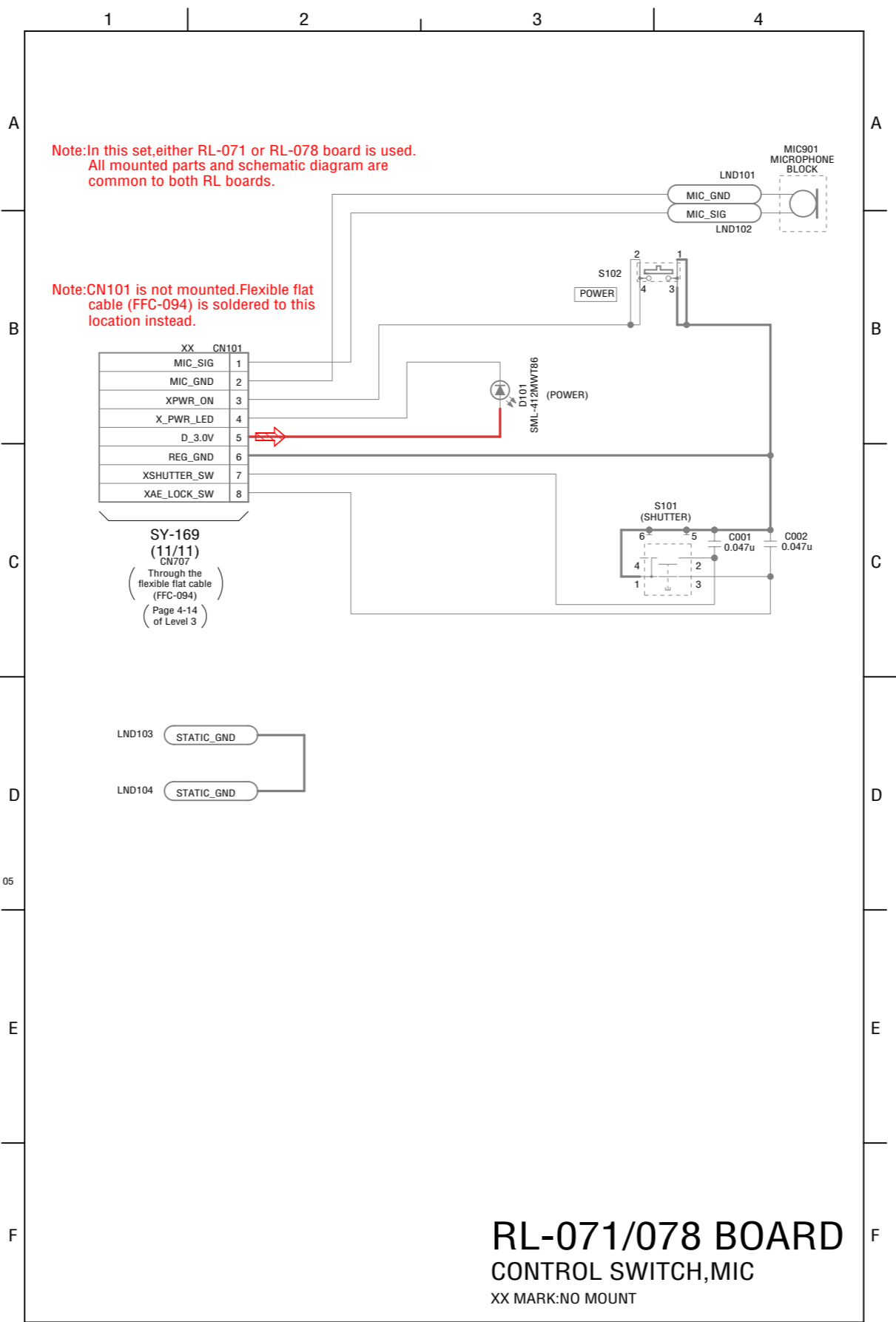

Signal location of the SY-169 board is not shown.  
Pages from 4-19 to 4-20 are not shown.

## 4-4. PRINTED WIRING BOARDS

### Link

• [MC-176 BOARD](#)

• [ST-160 BOARD](#)

• [SW-494 BOARD](#)

• [RL-071/078 BOARD](#)

• [COMMON NOTE FOR PRINTED WIRING BOARDS](#)



Printed wiring boards of the CD-694 flexible board and SY-169 board are not shown.  
Pages from 4-22 to 4-24 are not shown.

**MC-176 (4 layers), SW-494 (2 layers)**

**LF** : Uses unleaded solder.

**MC-176 BOARD (SIDE A)**

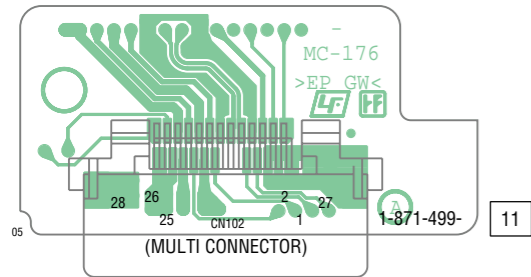

Note: CN102 (multi connector) is not supplied, but this is included in MC-176 complete board.

**MC-176 BOARD (SIDE B)**

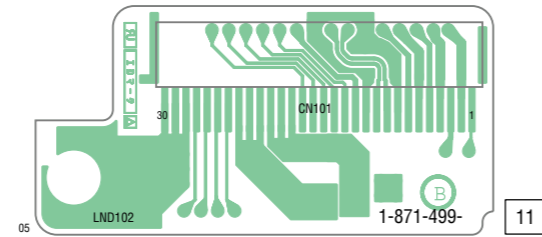

Note: CN101 is not mounted. Flexible flat cable (FFC-095) is soldered to this location instead. This FFC-095 is not supplied, but this is included in MC-176 complete board.

**SW-494 BOARD (SIDE A)**

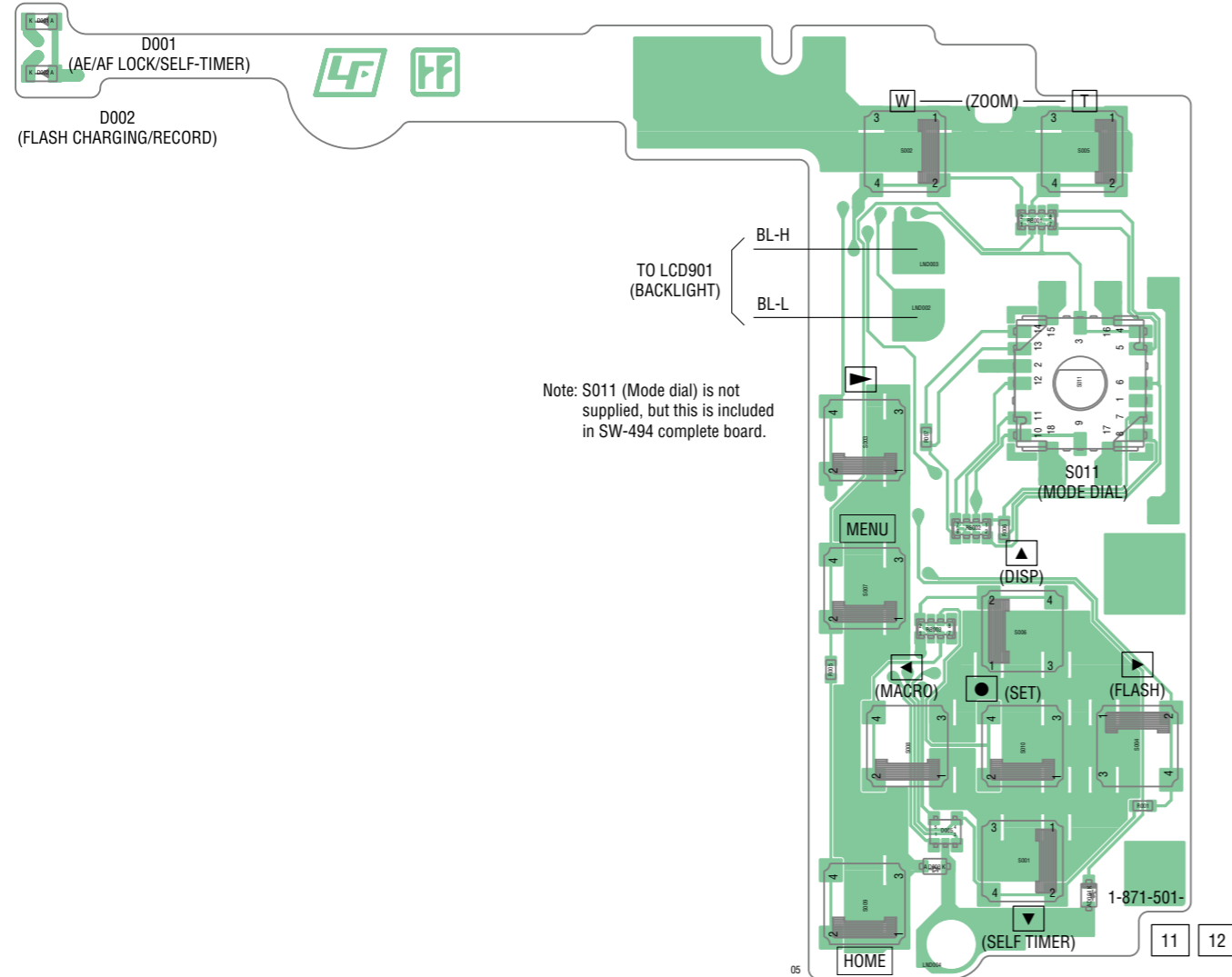

Note: S011 (Mode dial) is not supplied, but this is included in SW-494 complete board.

**SW-494 BOARD (SIDE B)**

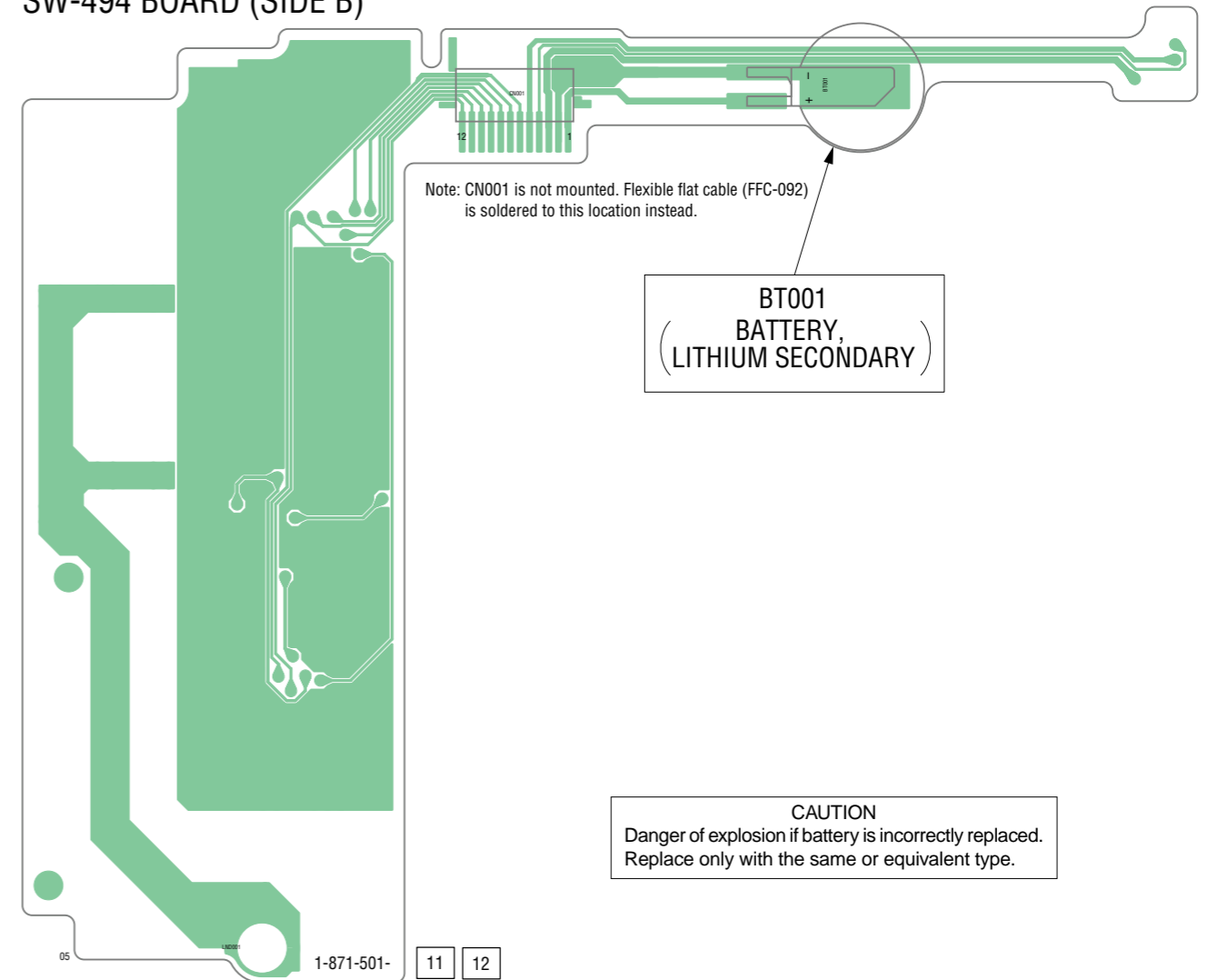

**CAUTION**  
Danger of explosion if battery is incorrectly replaced. Replace only with the same or equivalent type.



# 5. REPAIR PARTS LIST

NOTE: Characters **A** to **Z** of the electrical parts list indicate location of exploded views in which the desired part is shown.

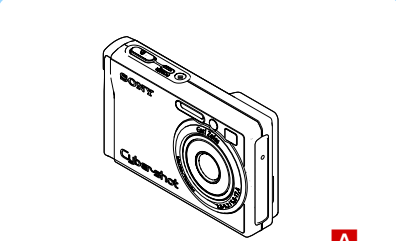
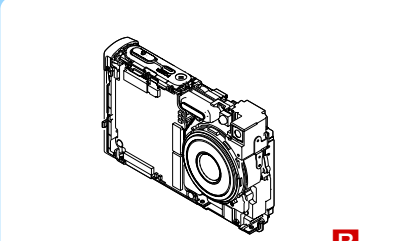
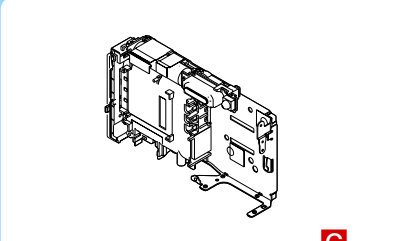
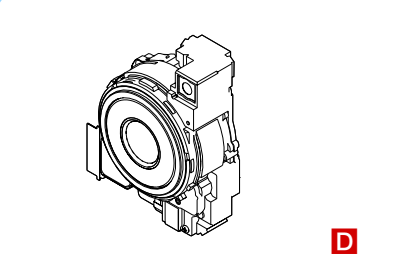
Link	EXPLODED VIEWS		
 <b>A</b>	 <b>B</b>	 <b>C</b>	
<b>CABINET SECTION</b>	<b>MAIN BOARD SECTION</b>	<b>LCD/BT HOLDER SECTION</b>	
 <b>D</b>			
<b>LENS SECTION</b>			

Link	ELECTRICAL PARTS LIST		ACCESSORIES
<a href="#">• MC-176 BOARD</a> <b>B</b>	<a href="#">• ST-160 BOARD</a> <b>C</b>	<a href="#">• SW-494 BOARD</a> <b>C</b>	
<a href="#">• RL-071/078 BOARD</a> <b>B</b>			

## 5. REPAIR PARTS LIST

### 5. REPAIR PARTS LIST

**NOTE:**

- -XX, -X mean standardized parts, so they may have some differences from the original one.
- Items marked “\*” are not stocked since they are seldom required for routine service. Some delay should be anticipated when ordering these items.
- The mechanical parts with no reference number in the exploded views are not supplied.
- Due to standardization, replacements in the parts list may be different from the parts specified in the diagrams or the components used on the set.
- CAPACITORS:  
  - uF:  $\mu$ F
- COILS  
  - uH:  $\mu$ H
- RESISTORS  
  - All resistors are in ohms.
  - METAL: metal-film resistor
  - METAL OXIDE: Metal Oxide-film resistor
  - F: nonflammable
- SEMICONDUCTORS  
  - In each case, u:  $\mu$ , for example:  
    - uA...:  $\mu$ A..., uPA...,  $\mu$ PA...,
    - uPB...,  $\mu$ PB...,  $\mu$ PC...,  $\mu$ PC...,
    - uPD...,  $\mu$ PD...
- Abbreviation  
  - AR : Argentine model
  - AUS : Australian model
  - BR : Brazilian model
  - CH : Chinese model
  - CND : Canadian model
  - EE : East European model
  - HK : Hong Kong model
  - J : Japanese model
  - JE : Tourist model
  - KR : Korea model
  - NE : North European model
  - TW : Taiwan model

When indicating parts by reference number, please include the board name.

The components identified by mark  $\Delta$  or dotted line with mark  $\Delta$  are critical for safety. Replace only with part number specified.

Les composants identifiés par une marque  $\Delta$  sont critiques pour la sécurité. Ne les remplacer que par une pièce portant le numéro spécifié.

- Color Indication of Appearance Parts  
  - Example:
  - (SILVER) : Cabinet's Color
  - (Silver) : Parts Color

# 5. REPAIR PARTS LIST

## DISASSEMBLY

## HARDWARE LIST

### 5-1. EXPLODED VIEWS

#### 5-1-1. CABINET SECTION

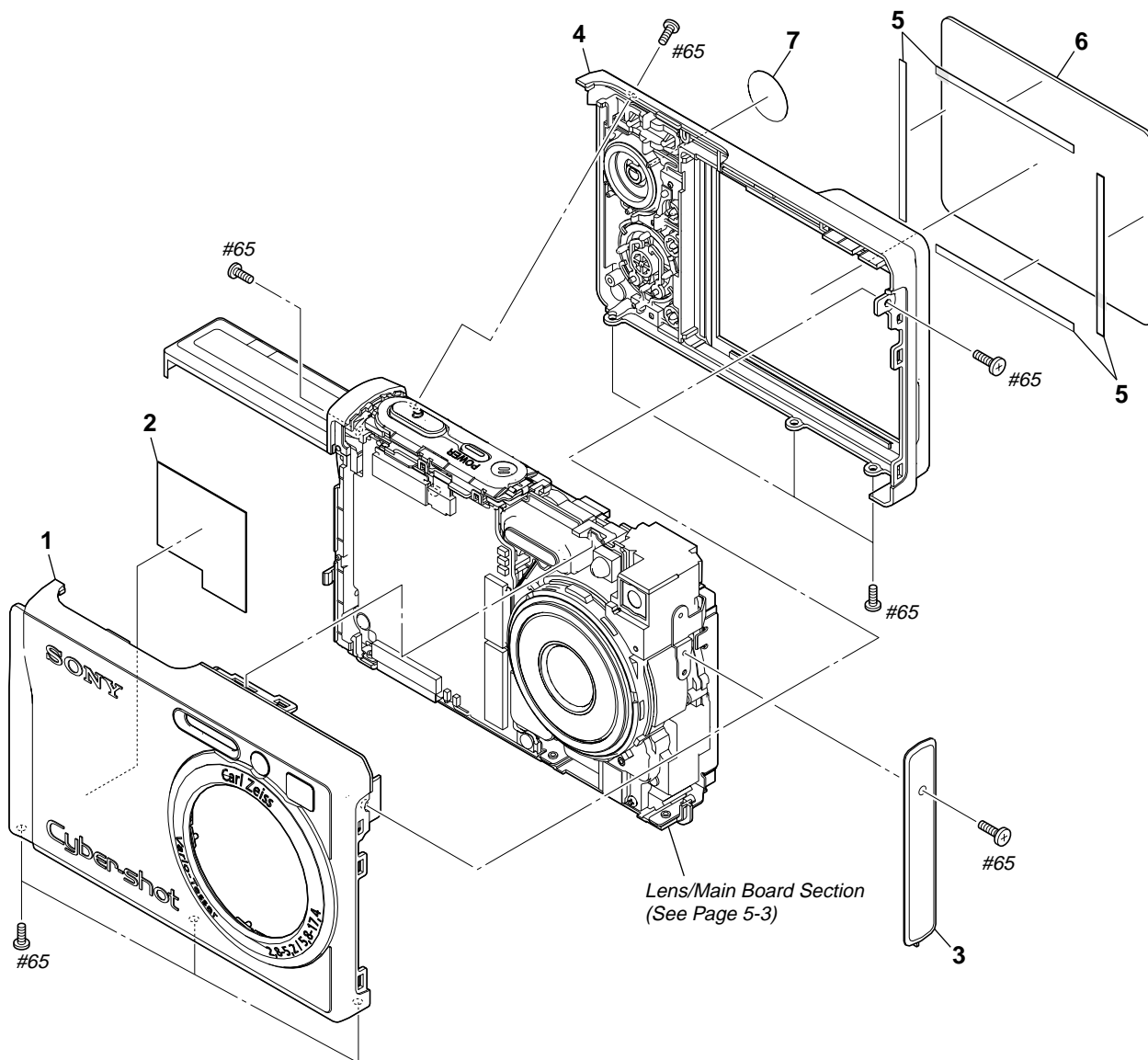

Ref. No.	Part No.	Description
1	X-2177-048-1	CABINET (FRONT) ASSY (SILVER)
1	X-2177-049-1	CABINET (FRONT) ASSY (BLACK)
* 2	3-197-910-01	SHEET, SY ELECTROSTATIC
3	3-099-623-01	CABINET, SIDE
4	X-2177-059-1	CABINET (REAR) ASSY (SILVER)

Ref. No.	Part No.	Description
4	X-2177-060-1	CABINET (REAR) ASSY (BLACK)
5	3-099-626-01	SHEET, LCD WINDOW ADHESIVE
6	3-099-624-01	WINDOW, LCD
7	3-099-625-01	PLATE, MODE
#65	2-635-591-01	SCREW (M1.4), NEW TRUSTAR P2 (Silver)

# 5. REPAIR PARTS LIST

## DISASSEMBLY

## HARDWARE LIST

### 5-1-2. MAIN BOARD SECTION

ns: not supplied

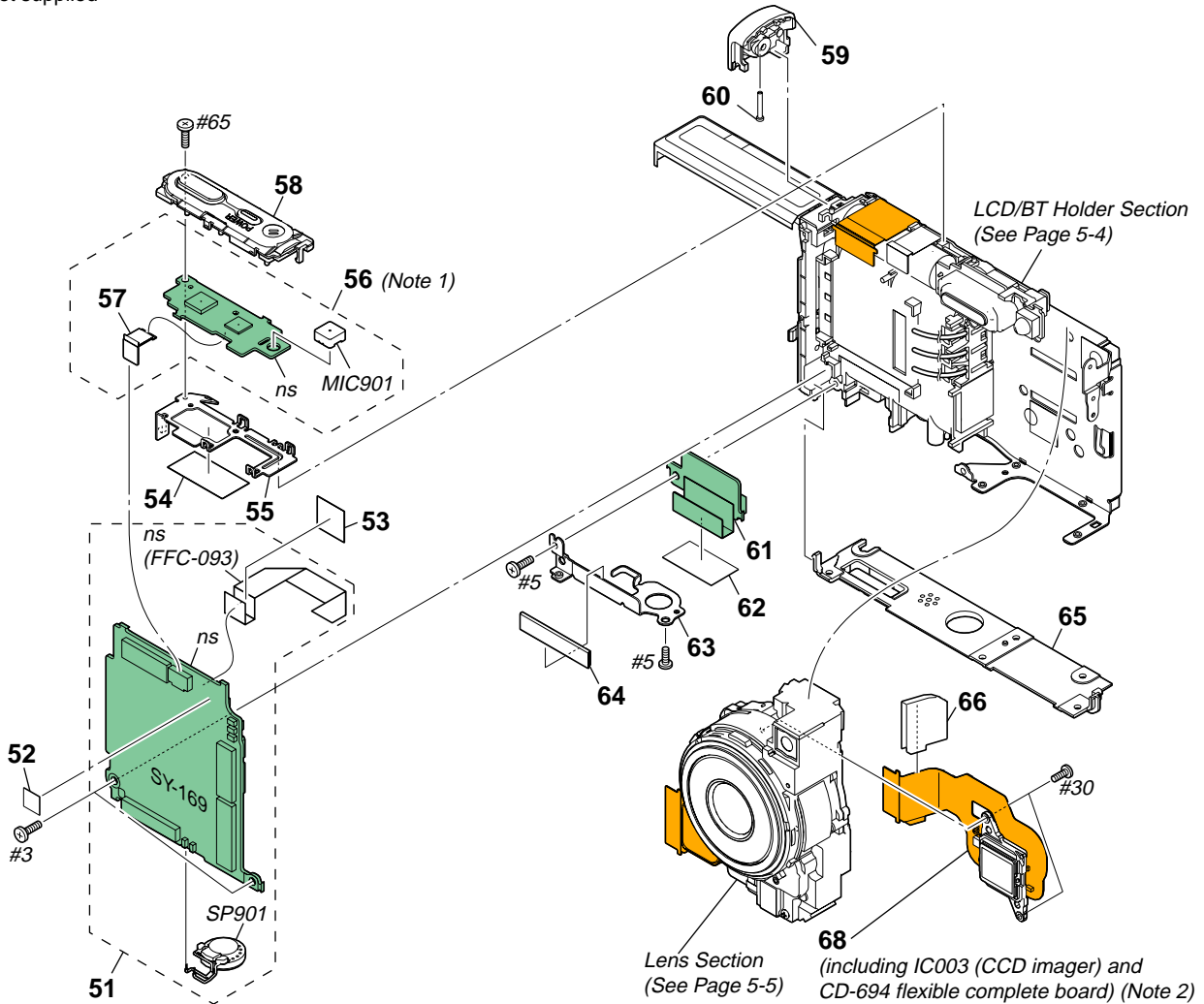

Note 1: In this set, either RL-071 or RL-078 board is used. All mounted parts and schematic diagram are common to both RL boards.

Note 2: Be sure to read "Precautions for Replacement of Imager" of level 3 on page 4-2.

Ref. No.	Part No.	Description
51	A-1253-157-A	SY-169 BOARD, COMPLETE (SERVICE)
52	3-099-637-01	LABEL, FUSE
* 53	3-099-634-01	SHEET, ST INSULATING
* 54	3-099-636-01	SHEET, RL INSULATING
55	3-099-620-01	RETAINER, RELEASE
56	A-1246-054-A	RL-071 BOARD, COMPLETE (Note 1)
56	A-1271-235-A	RL-078 BOARD, COMPLETE (Note 1)
57	1-833-618-11	CABLE, FLEXIBLE FLAT (FFC-094)
58	X-2177-054-1	RELEASE ASSY
59	3-099-621-01	CABINET, UPPER
60	3-099-622-01	SHAFT, STRAP
61	A-1246-051-A	MC-176 BOARD, COMPLETE
* 62	3-099-639-01	SHEET, MC RADIATION
* 63	3-099-629-01	RETAINER, MULTI

Ref. No.	Part No.	Description
* 64	3-099-635-01	SHEET, MC INSULATING
65	3-099-632-01	CABINET BOTTOM (SILVER)
65	3-099-632-11	CABINET BOTTOM (BLACK)
66	3-113-705-01	SHEET (PLUS), CD RADIATION
68	A-1253-767-A	CCD BLOCK ASSY (including IC003 (CCD IMAGER) and CD-694 flexible complete board) (Note 2)
MIC901	1-542-721-11	MICROPHONE BLOCK
SP901	1-826-614-21	LOUD SPEAKER (1.0CM)
#3	2-660-401-01	SCREW (M1.7), NEW TRU-STAR, P2 (Red)
#5	3-080-204-01	SCREW, TAPPING, P2 (Black)
#30	3-086-156-11	SCREW B1.2 (White)
#65	2-635-591-01	SCREW (M1.4), NEW TRUSTAR P2 (Silver)

# 5. REPAIR PARTS LIST

## DISASSEMBLY

## HARDWARE LIST

### 5-1-3. LCD/BT HOLDER SECTION

ns: not supplied

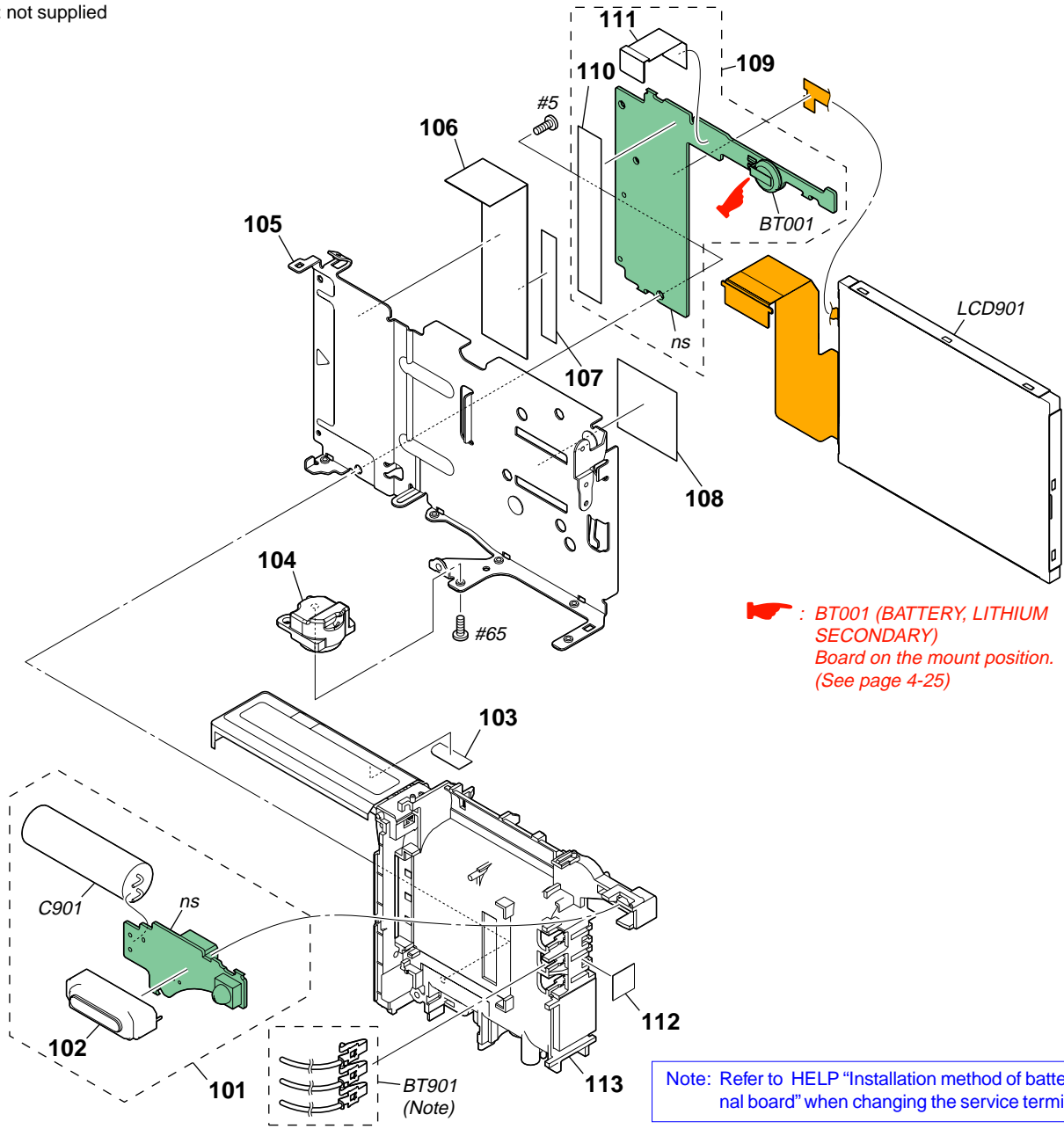

• Refer to page 5-1 for mark ▲.

Ref. No.	Part No.	Description
101	A-1246-052-A	ST-160 BOARD, COMPLETE
▲ 102	1-480-014-11	FLASH UNIT
* 103	3-113-323-01	LABEL, MS CAUTION
104	3-099-631-01	SCREW, TRIPOD
105	3-099-627-01	FRAME, MAIN
106	3-099-633-01	SHEET, LC FLEXIBLE
* 107	3-100-059-01	SHEET, LC FLEXIBLE ADHESIVE
* 108	3-197-557-01	SHEET, LIGHT INTERCEPTION
109	A-1246-053-A	SW-494 BOARD, COMPLETE
* 110	3-100-060-01	SHEET, SW

Ref. No.	Part No.	Description
111	1-833-616-11	CABLE, FLEXIBLE FLAT (FFC-092)
* 112	3-198-159-01	SHEET, BT TERMINAL
113	X-2177-056-1	HOLDER ASSY, BT
▲ BT001	1-756-710-11	LITHIUM RECHARGEABLE BATTERY
BT901	A-1257-452-A	TERMINAL, SERVICE (BT) (Note)
▲* C901	1-114-309-11	ELECT 49uF 315V
LCD901	1-802-379-11	LCD MODULE (LQ025A3DD01)
#5	3-080-204-01	SCREW, TAPPING, P2 (Black)
#65	2-635-591-01	SCREW (M1.4), NEW TRUSTAR P2 (Silver)

# 5. REPAIR PARTS LIST

## HARDWARE LIST

### 5-1-4. LENS SECTION

ns: not supplied

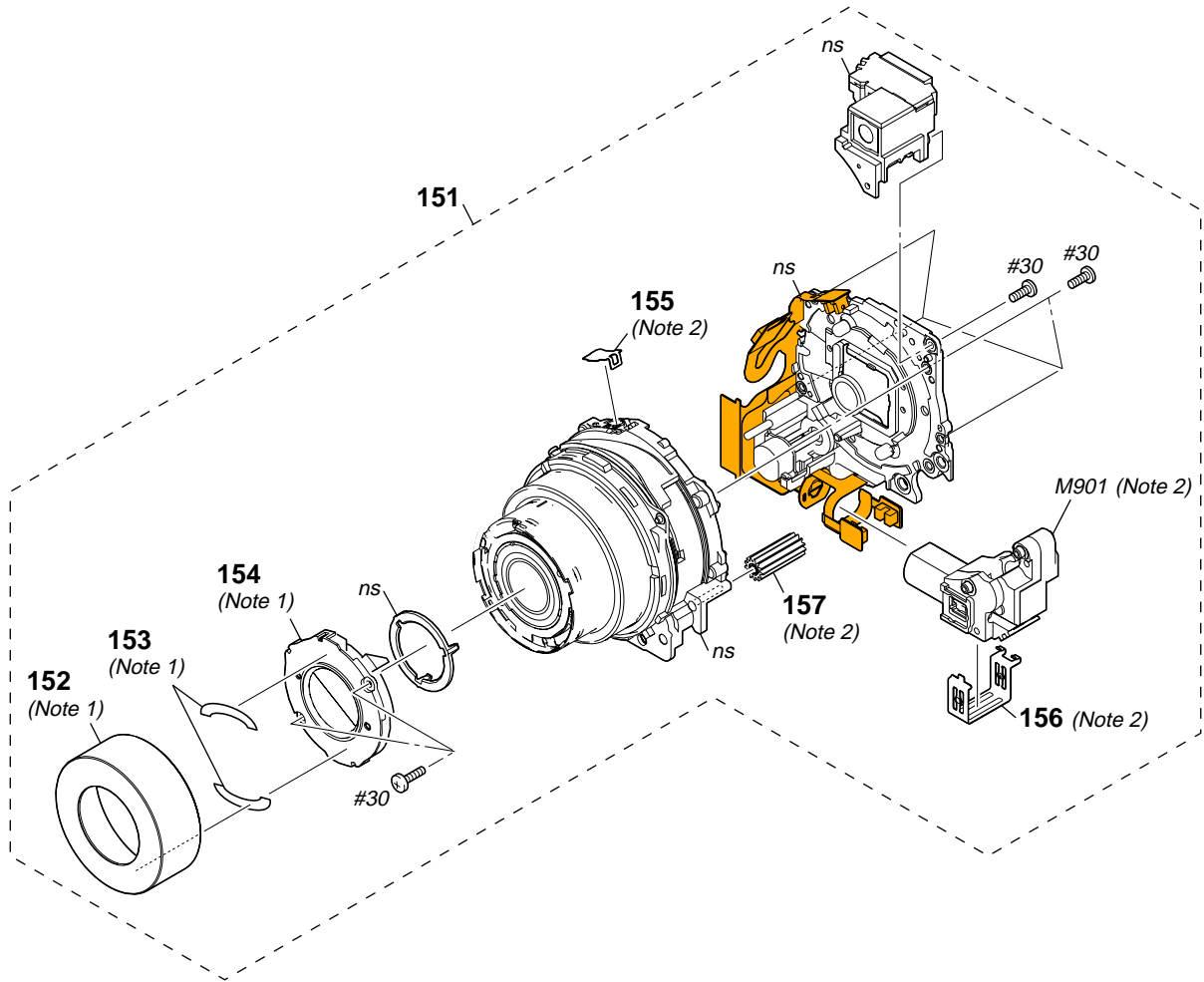

Note 1: Be sure to read "Exchange method of barrier block" on page 2-6.

Note 2: Be sure to read "Exchange method of zoom gear block" on page 2-8.

Ref. No.	Part No.	Description
151	A-1231-924-A	LSV-1160A (SERVICE)
152	2-689-851-01	RING (A), ORNAMENTAL (Note 1)
153	2-691-890-01	TAPE, BARRIER (Note 1)
154	A-1205-001-A	BARRIER BLOCK ASSY (Note 1)
155	2-689-849-01	SPRING, Z LEAF (Note 2)

Ref. No.	Part No.	Description
156	2-689-850-01	SPRING, FG LEAF (Note 2)
157	2-689-871-01	GEAR, NARUTO (Note 2)
M901	1-479-864-11	GEAR BLOCK, ZOOM (1160) (Note 2)
#30	3-086-156-11	SCREW B1.2 (White)

Electrical parts list of the CD-694 flexible board is not shown.  
Page 5-6 is not shown.

## 5-2. ELECTRICAL PARTS LIST

Ref. No.	Part No.	Description
	A-1246-051-A	MC-176 BOARD, COMPLETE *****
		(Flexible flat cable (FFC-095) and CN102 are not supplied, but they are included in MC-176 complete board.)
	(Not supplied)	CABLE, FLEXIBLE FLAT (FFC-095) < CONNECTOR >
CN102	(Not supplied)	CONNECTOR, MULTIPLE (SOCKET) (MULTI CONNECTOR)

A-1246-054-A RL-071 BOARD, COMPLETE  
A-1271-235-A RL-078 BOARD, COMPLETE  
\*\*\*\*\*

Note: In this set, either RL-071 or RL-078 board is used.  
All mounted parts and schematic diagram are com-  
mon to both RL boards.

	1-833-618-11	CABLE, FLEXIBLE FLAT (FFC-094) < CAPACITOR >
C001	1-119-923-11	CERAMIC CHIP 0.047uF 10% 10V
C002	1-119-923-11	CERAMIC CHIP 0.047uF 10% 10V < DIODE >
D101	6-501-030-01	DIODE SML-412MWT86 (POWER) < MICROPHONE >
MIC901	1-542-721-11	MICROPHONE BLOCK < SWITCH >
* S101	1-786-912-21	TACTILE SWITCH (SHUTTER)
S102	1-786-885-42	SWITCH, TACTILE (POWER)
	A-1246-052-A	ST-160 BOARD, COMPLETE *****
△	1-480-014-11	FLASH UNIT < CAPACITOR >
C001	1-100-611-91	CERAMIC CHIP 22uF 20% 6.3V
C002	1-112-717-91	CERAMIC CHIP 1uF 10% 6.3V
△ C004	1-100-758-11	CERAMIC CHIP 0.047uF 10% 250V
C007	1-164-933-11	CERAMIC CHIP 220PF 10% 50V
△*C901	1-114-309-11	ELECT 49uF 315V < CONNECTOR >
CN001	1-779-330-51	FFC/CONNECTOR, FPC (LIF (NON-ZIF)) 12P < DIODE >
△*D001	6-501-433-01	DIODE MA2YF8000LS0
* D002	6-501-861-01	DIODE CL-360S-TD4-X-TL (SELF-TIMER/AF ILLUMINATOR)
D003	6-500-619-01	DIODE RB520S-40TE61

Ref. No.	Part No.	Description
		< IC >
IC001	6-707-555-01	IC TPS65552RGTR
		< COIL >
* L001	1-400-820-11	INDUCTOR 2.2uH < TRANSISTOR >
△*Q001	6-551-452-01	TRANSISTOR CY25BAJ-8F-T23-G02 < RESISTOR >
R002	1-218-989-11	RES-CHIP 1M 5% 1/16W
R003	1-218-941-11	RES-CHIP 100 5% 1/16W
△ R004	1-216-121-11	RES-CHIP 1M 5% 1/10W
R006	1-218-961-11	RES-CHIP 4.7K 5% 1/16W < TRANSFORMER >
△ T001	1-445-108-21	TRANSFORMER, D.C-D.C CONVERTER
	A-1246-053-A	SW-494 BOARD, COMPLETE *****
		(S011 (mode dial) is not supplied, but this is included in SW-494 complete board.)
	1-833-616-11	CABLE, FLEXIBLE FLAT (FFC-092)
* 3-100-060-01		SHEET, SW < LITHIUM BATTERY >
△ BT001	1-756-710-11	LITHIUM RECHARGEABLE BATTERY < DIODE >
D001	8-719-075-29	DIODE SML-510MWT86S (AE/AF LOCK/SELF-TIMER)
D002	8-719-077-34	DIODE SML-310YT86 (FLASH CHARGING/RECORD) < RESISTOR >
R001	1-218-957-11	RES-CHIP 2.2K 5% 1/16W
R005	1-218-957-11	RES-CHIP 2.2K 5% 1/16W
R006	1-218-957-11	RES-CHIP 2.2K 5% 1/16W
R007	1-218-957-11	RES-CHIP 2.2K 5% 1/16W < COMPOSITION CIRCUIT BLOCK >
RB001	1-234-376-11	RES, NETWORK 2.2K (1005X4)
RB002	1-234-376-11	RES, NETWORK 2.2K (1005X4)
RB003	1-234-376-11	RES, NETWORK 2.2K (1005X4) < SWITCH >
S001	1-786-885-42	SWITCH, TACTILE (▼ (SELF-TIMER))
S002	1-786-885-42	SWITCH, TACTILE (W (ZOOM))
S003	1-786-885-42	SWITCH, TACTILE (▶)
S004	1-786-885-42	SWITCH, TACTILE (► (FLASH))
S005	1-786-885-42	SWITCH, TACTILE (T (ZOOM))
S006	1-786-885-42	SWITCH, TACTILE (▲ (DISP))
S007	1-786-885-42	SWITCH, TACTILE (MENU)
S008	1-786-885-42	SWITCH, TACTILE (◀ (MACRO))

• Refer to page 5-1 for mark △.

CAUTION  
Danger of explosion if battery is incorrectly replaced.  
Replace only with the same or equivalent type.

<u>Ref. No.</u>	<u>Part No.</u>	<u>Description</u>
S009	1-786-885-42	SWITCH, TACTILE (HOME)
S010	1-786-885-42	SWITCH, TACTILE (● (SET))
S011	(Not supplied)	ROTARY SWITCH (MODE DIAL)

Electrical parts list of the SY-169 board is not shown.  
Pages 5-9 to 5-13 are not shown.

## Checking supplied accessories.

Note: This item is supplied with the unit as an accessory, but is not prepared as a service part.

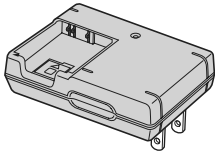

Battery Charger  
BC-CSGB  
△ 1-479-791-22 (US, CND)

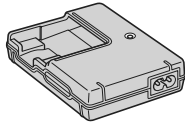

Battery Charger  
BC-CSGB  
△ 1-479-791-32  
(EXCEPT US, CND,  
E: Latin America, BR)  
BC-CSGC  
△ 1-480-175-31  
(E: Latin America)

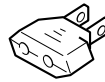

Conversion (2P) Adaptor  
△ 1-569-008-12 (E: NTSC)

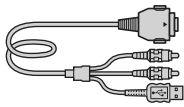

USB, A/V Cable for  
Multi-use Terminal  
1-829-866-41

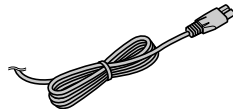

Power Cord  
△ 1-555-074-91 (AUS)  
△ 1-782-476-71 (CH)  
△ 1-823-947-71 (KR)  
△ 1-827-269-31 (UK, HK)  
△ 1-827-826-41 (AEP, E)  
△ 1-832-106-31 (AR)



Instruction Manual  
3-095-004-11 (ENGLISH) (EXCEPT US, BR)  
3-095-004-21 (FRENCH, ITALIAN) (CND, AEP)  
3-095-004-31 (SPANISH, PORTUGUESE) (AEP, E, AR)  
3-095-004-41 (GERMAN, DUTCH) (AEP)  
3-095-004-51 (TRADITIONAL CHINESE,  
SIMPLIFIED CHINESE) (E, HK, CH)  
3-095-004-61 (RUSSIAN) (AEP)  
3-095-004-71 (ARABIC, PERSIAN) (E)  
3-095-004-81 (KOREAN) (KR)  
3-095-004-91 (POLISH, CZECH) (AEP)  
3-095-005-11 (HUNGARIAN, SLOVAK) (AEP)  
3-095-005-21 (SWEDISH, FINNISH) (AEP)  
3-095-005-31 (NORWEGIAN, DANISH) (AEP)  
3-095-005-41 (THAI, MALAY) (E)  
3-095-005-51 (TURKISH, GREEK) (AEP)  
3-095-005-61 (ENGLISH, SPANISH) (US)

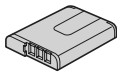

Rechargeable Battery Pack  
NP-BG1  
(Note)

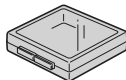

Battery Case  
(Note)

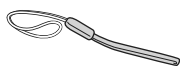

Wrist Strap  
2-050-981-01

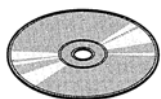

CD-ROM  
(Cyber-shot Application Software/  
"Cyber-shot Handbook"/  
"Cyber-shot Step-up Guide")  
3-094-911-01 (EXCEPT US)  
3-196-435-01 (US)

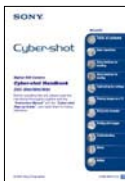

Cyber-shot Handbook (PDF)

The CD-ROM supplied contains all of language version of the Instruction Manual in pdf (Cyber-shot Handbook.pdf) for printing.  
Note: The printed matter is not supplied. If required, please order it with the part number below.

3-094-994-01 (JAPANESE)	3-094-995-41 (KOREAN)
3-094-994-11 (ENGLISH)	3-094-995-51 (POLISH)
3-094-994-21 (FRENCH)	3-094-995-61 (CZECH)
3-094-994-31 (ITALIAN)	3-094-995-71 (HUNGARIAN)
3-094-994-41 (SPANISH)	3-094-995-81 (SLOVAK)
3-094-994-51 (PORTUGUESE)	3-094-995-91 (SWEDISH)
3-094-994-61 (GERMAN)	3-094-996-11 (FINNISH)
3-094-994-71 (DUTCH)	3-094-996-21 (NORWEGIAN)
3-094-994-81 (TRADITIONAL CHINESE)	3-094-996-31 (DANISH)
3-094-994-91 (SIMPLIFIED CHINESE)	3-094-996-41 (THAI)
3-094-995-11 (RUSSIAN)	3-094-996-51 (MALAY)
3-094-995-21 (ARABIC)	3-094-996-61 (TURKISH)
3-094-995-31 (PERSIAN)	3-094-996-71 (GREEK)

• Refer to the page 5-1 for mark △.

# DSC-W90

SONY®

LEVEL 2

## SERVICE MANUAL

Ver. 1.2 2007.07

*US Model  
Canadian Model  
AEP Model  
UK Model  
E Model  
Australian Model  
Hong Kong Model  
Chinese Model  
Korea Model  
Argentine Model  
Brazilian Model*

## SUPPLEMENT-1

File this supplement with the service manual.  
(D107-042)

- Change of Repair Parts
- Change of Board's Suffix No.

- Suffix No. of MC-176, and ST-160 boards have been changed from **11** into **12**, **22**.  
About suffix No. **11** and **12**, **22**, there are no change of schematic diagram and printed wiring board.

# 5. REPAIR PARTS LIST

## 5-1. EXPLODED VIEWS

 : Points added portion.

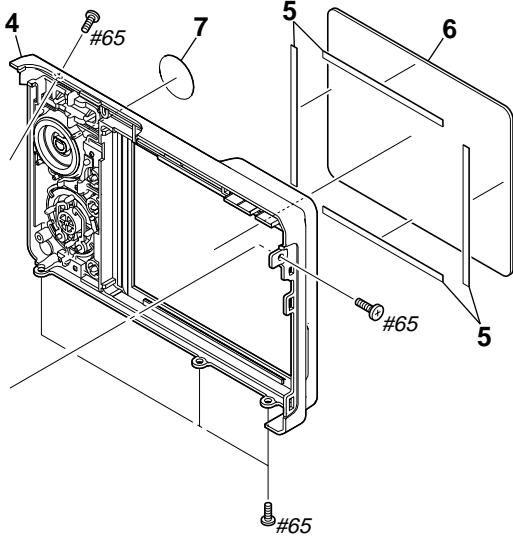
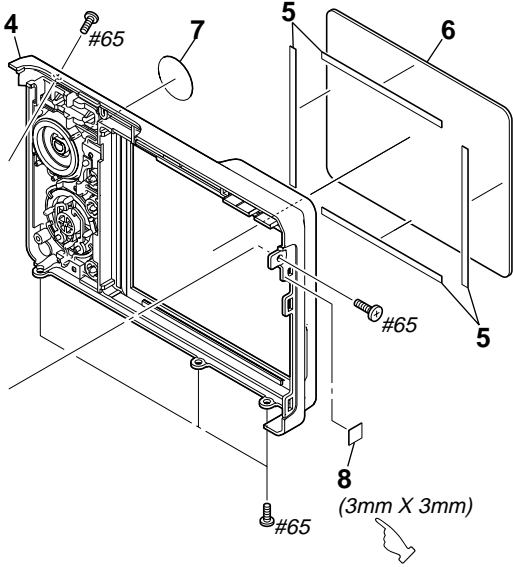
Page	Former	New												
5-2		 <div data-bbox="863 965 1441 1055" style="border: 1px solid black; padding: 5px;"> <p><b>CAUTION:</b> For the part of 8, cut SHEET (SW), ELECTROSTATIC (2-348-474-01) into the desired length and use it.</p> </div>												
	<table border="1"> <thead> <tr> <th data-bbox="220 1066 288 1093">Ref. No.</th> <th data-bbox="316 1066 384 1093">Part No.</th> <th data-bbox="453 1066 555 1093">Description</th> </tr> </thead> <tbody> <tr> <td data-bbox="245 1099 261 1122">—</td> <td data-bbox="316 1099 416 1122">—</td> <td data-bbox="453 1099 683 1122">—</td> </tr> </tbody> </table>	Ref. No.	Part No.	Description	—	—	—	<table border="1"> <thead> <tr> <th data-bbox="850 1066 919 1093">Ref. No.</th> <th data-bbox="946 1066 1015 1093">Part No.</th> <th data-bbox="1083 1066 1185 1093">Description</th> </tr> </thead> <tbody> <tr> <td data-bbox="876 1099 892 1122">8</td> <td data-bbox="946 1099 1031 1122">CAUTION</td> <td data-bbox="1083 1099 1329 1122">SHEET, LE SIDE RADIATION</td> </tr> </tbody> </table>	Ref. No.	Part No.	Description	8	CAUTION	SHEET, LE SIDE RADIATION
Ref. No.	Part No.	Description												
—	—	—												
Ref. No.	Part No.	Description												
8	CAUTION	SHEET, LE SIDE RADIATION												

 : Points added portion.

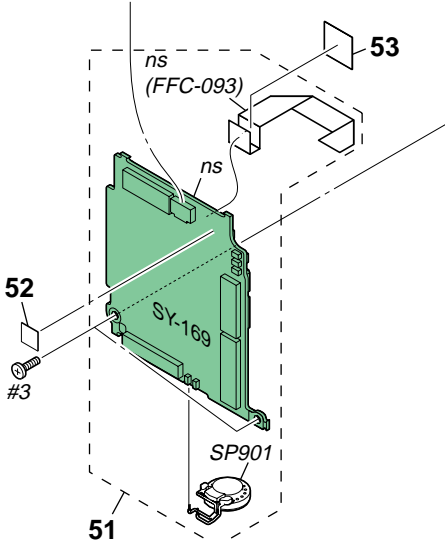
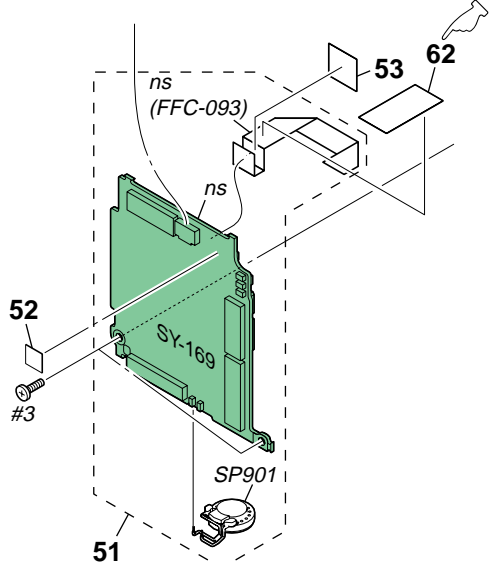
Page	Former	New																					
5-3	 <table border="1"> <thead> <tr> <th>Ref. No.</th> <th>Part No.</th> <th>Description</th> </tr> </thead> <tbody> <tr> <td>52</td> <td>3-099-637-01</td> <td>LABEL, FUSE</td> </tr> <tr> <td>56</td> <td>A-1246-054-A</td> <td>RL-071 BOARD, COMPLETE (Note 1)</td> </tr> <tr> <td>56</td> <td>A-1271-235-A</td> <td>RL-078 BOARD, COMPLETE (Note 1)</td> </tr> </tbody> </table>	Ref. No.	Part No.	Description	52	3-099-637-01	LABEL, FUSE	56	A-1246-054-A	RL-071 BOARD, COMPLETE (Note 1)	56	A-1271-235-A	RL-078 BOARD, COMPLETE (Note 1)	 <table border="1"> <thead> <tr> <th>Ref. No.</th> <th>Part No.</th> <th>Description</th> </tr> </thead> <tbody> <tr> <td>52</td> <td>3-099-637-03</td> <td>LABEL, FUSE</td> </tr> <tr> <td>56</td> <td>A-1246-054-A</td> <td>RL-071 BOARD, COMPLETE (Note 1, 2)</td> </tr> </tbody> </table> <div style="border: 1px solid black; padding: 5px; margin-top: 10px;"> <p>Note 2: The RL-071 flexible board is compatible with the RL-078 flexible board. When replace the RL-078 flexible board, change it to the RL-071 flexible board.</p> </div>	Ref. No.	Part No.	Description	52	3-099-637-03	LABEL, FUSE	56	A-1246-054-A	RL-071 BOARD, COMPLETE (Note 1, 2)
Ref. No.	Part No.	Description																					
52	3-099-637-01	LABEL, FUSE																					
56	A-1246-054-A	RL-071 BOARD, COMPLETE (Note 1)																					
56	A-1271-235-A	RL-078 BOARD, COMPLETE (Note 1)																					
Ref. No.	Part No.	Description																					
52	3-099-637-03	LABEL, FUSE																					
56	A-1246-054-A	RL-071 BOARD, COMPLETE (Note 1, 2)																					
5-4	<table border="1"> <tbody> <tr> <td>* 112</td> <td>3-198-159-01</td> <td>SHEET, BT TERMINAL</td> </tr> <tr> <td>△BT001</td> <td>1-756-710-11</td> <td>LITHIUM RECHARGEABLE BATTERY</td> </tr> </tbody> </table>	* 112	3-198-159-01	SHEET, BT TERMINAL	△BT001	1-756-710-11	LITHIUM RECHARGEABLE BATTERY	<table border="1"> <tbody> <tr> <td>* 112</td> <td>3-198-159-02</td> <td>SHEET, BT TERMINAL</td> </tr> <tr> <td>△BT001</td> <td>1-756-711-11</td> <td>LITHIUM RECHARGEABLE BATTERY</td> </tr> </tbody> </table>	* 112	3-198-159-02	SHEET, BT TERMINAL	△BT001	1-756-711-11	LITHIUM RECHARGEABLE BATTERY									
* 112	3-198-159-01	SHEET, BT TERMINAL																					
△BT001	1-756-710-11	LITHIUM RECHARGEABLE BATTERY																					
* 112	3-198-159-02	SHEET, BT TERMINAL																					
△BT001	1-756-711-11	LITHIUM RECHARGEABLE BATTERY																					

## 5-2. ELECTRICAL PARTS LIST



Page	Former	New																								
5-7	<table border="1"> <thead> <tr> <th>Ref. No.</th> <th>Part No.</th> <th>Description</th> </tr> </thead> <tbody> <tr> <td></td> <td>A-1246-054-A</td> <td>RL-071 BOARD, COMPLETE</td> </tr> <tr> <td></td> <td>A-1271-235-A</td> <td>RL-078 BOARD, COMPLETE</td> </tr> <tr> <td></td> <td colspan="2">*****</td> </tr> </tbody> </table>	Ref. No.	Part No.	Description		A-1246-054-A	RL-071 BOARD, COMPLETE		A-1271-235-A	RL-078 BOARD, COMPLETE		*****		<table border="1"> <thead> <tr> <th>Ref. No.</th> <th>Part No.</th> <th>Description</th> </tr> </thead> <tbody> <tr> <td></td> <td>A-1246-054-A</td> <td>RL-071 BOARD, COMPLETE</td> </tr> <tr> <td></td> <td colspan="2">*****</td> </tr> <tr> <td></td> <td colspan="2">The RL-071 flexible board is compatible with the RL-078 flexible board. When replace the RL-078 flexible board, change it to the RL-071 flexible board.</td> </tr> </tbody> </table>	Ref. No.	Part No.	Description		A-1246-054-A	RL-071 BOARD, COMPLETE		*****			The RL-071 flexible board is compatible with the RL-078 flexible board. When replace the RL-078 flexible board, change it to the RL-071 flexible board.	
Ref. No.	Part No.	Description																								
	A-1246-054-A	RL-071 BOARD, COMPLETE																								
	A-1271-235-A	RL-078 BOARD, COMPLETE																								
	*****																									
Ref. No.	Part No.	Description																								
	A-1246-054-A	RL-071 BOARD, COMPLETE																								
	*****																									
	The RL-071 flexible board is compatible with the RL-078 flexible board. When replace the RL-078 flexible board, change it to the RL-071 flexible board.																									
5-7	<table border="1"> <tbody> <tr> <td></td> <td>A-1246-052-A</td> <td>ST-160 BOARD, COMPLETE</td> </tr> <tr> <td></td> <td colspan="2">*****</td> </tr> <tr> <td></td> <td colspan="2">&lt; TRANSISTOR &gt;</td> </tr> <tr> <td></td> <td>△*Q001</td> <td>6-551-452-01 TRANSISTOR CY25BAJ-8F-T23-G02</td> </tr> </tbody> </table>		A-1246-052-A	ST-160 BOARD, COMPLETE		*****			< TRANSISTOR >			△*Q001	6-551-452-01 TRANSISTOR CY25BAJ-8F-T23-G02	<table border="1"> <tbody> <tr> <td></td> <td>A-1246-052-A</td> <td>ST-160 BOARD, COMPLETE</td> </tr> <tr> <td></td> <td colspan="2">*****</td> </tr> <tr> <td></td> <td colspan="2">&lt; TRANSISTOR &gt;</td> </tr> <tr> <td></td> <td>△*Q001</td> <td>6-551-676-01 TRANSISTOR CY25BAJ-8F-T13-G12</td> </tr> </tbody> </table>		A-1246-052-A	ST-160 BOARD, COMPLETE		*****			< TRANSISTOR >			△*Q001	6-551-676-01 TRANSISTOR CY25BAJ-8F-T13-G12
	A-1246-052-A	ST-160 BOARD, COMPLETE																								
	*****																									
	< TRANSISTOR >																									
	△*Q001	6-551-452-01 TRANSISTOR CY25BAJ-8F-T23-G02																								
	A-1246-052-A	ST-160 BOARD, COMPLETE																								
	*****																									
	< TRANSISTOR >																									
	△*Q001	6-551-676-01 TRANSISTOR CY25BAJ-8F-T13-G12																								
5-7	<table border="1"> <tbody> <tr> <td></td> <td>A-1246-053-A</td> <td>SW-494 BOARD, COMPLETE</td> </tr> <tr> <td></td> <td colspan="2">*****</td> </tr> <tr> <td></td> <td colspan="2">&lt; LITHIUM BATTERY &gt;</td> </tr> <tr> <td></td> <td>△BT001</td> <td>1-756-710-11 LITHIUM RECHARGEABLE BATTERY</td> </tr> </tbody> </table>		A-1246-053-A	SW-494 BOARD, COMPLETE		*****			< LITHIUM BATTERY >			△BT001	1-756-710-11 LITHIUM RECHARGEABLE BATTERY	<table border="1"> <tbody> <tr> <td></td> <td>A-1246-053-A</td> <td>SW-494 BOARD, COMPLETE</td> </tr> <tr> <td></td> <td colspan="2">*****</td> </tr> <tr> <td></td> <td colspan="2">&lt; LITHIUM BATTERY &gt;</td> </tr> <tr> <td></td> <td>△BT001</td> <td>1-756-711-11 LITHIUM RECHARGEABLE BATTERY</td> </tr> </tbody> </table>		A-1246-053-A	SW-494 BOARD, COMPLETE		*****			< LITHIUM BATTERY >			△BT001	1-756-711-11 LITHIUM RECHARGEABLE BATTERY
	A-1246-053-A	SW-494 BOARD, COMPLETE																								
	*****																									
	< LITHIUM BATTERY >																									
	△BT001	1-756-710-11 LITHIUM RECHARGEABLE BATTERY																								
	A-1246-053-A	SW-494 BOARD, COMPLETE																								
	*****																									
	< LITHIUM BATTERY >																									
	△BT001	1-756-711-11 LITHIUM RECHARGEABLE BATTERY																								

<p>The components identified by mark △ or dotted line with mark △ are critical for safety. Replace only with part number specified.</p>	<p>Les composants identifiés par une marque △ sont critiques pour la sécurité. Ne les remplacer que par une pièce portant le numéro spécifié.</p>
---	---

## Checking supplied accessories.

 : Points changed portion.

 : Points deleted portion.

The components identified by mark  or dotted line with mark  are critical for safety. Replace only with part number specified.

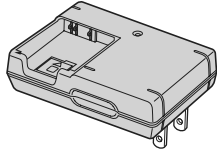

Les composants identifiés par une marque  sont critiques pour la sécurité. Ne les remplacer que par une pièce portant le numéro spécifié.

Note: This item is supplied with the unit as an accessory, but is not prepared as a service part.



Battery Charger

BC-CSGC

  1-480-175-21 (US, CND)

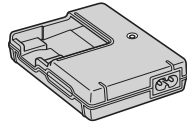

Battery Charger

~~BC-CSGB~~

~~ 1-479-791-32~~

~~(EXCEPT US, CND,~~

~~E, Latin America, BR)~~

BC-CSGC

 1-480-175-31

(EXCEPT US, CND, BR)

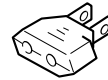

Conversion (2P) Adaptor

 1-569-008-12 (E: NTSC)

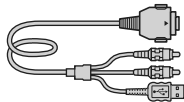



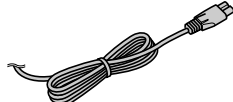

USB, A/V Cable for  
Multi-use Terminal



1-829-866-51







Power Cord



  1-827-945-61 (AUS)

  1-832-121-31 (CH)

  1-823-947-71 (KR)

  1-832-169-31 (UK, HK)

  1-824-910-31 (AEP, E)

  1-832-106-31 (AR)



Instruction Manual

 3-095-004-12 (ENGLISH) (EXCEPT US, BR)

 3-095-004-22 (FRENCH, ITALIAN) (CND, AEP)

 3-095-004-32 (SPANISH, PORTUGUESE) (AEP, E, AR)

 3-095-004-42 (GERMAN, DUTCH) (AEP)

 3-095-004-52 (TRADITIONAL CHINESE,  
SIMPLIFIED CHINESE) (E, HK, CH)

 3-095-004-62 (RUSSIAN) (AEP)

 3-095-004-72 (ARABIC, PERSIAN) (E)

 3-095-004-82 (KOREAN) (KR)

 3-095-004-92 (POLISH, CZECH) (AEP)

 3-095-005-12 (HUNGARIAN, SLOVAK) (AEP)

 3-095-005-22 (SWEDISH, FINNISH) (AEP)

 3-095-005-32 (NORWEGIAN, DANISH) (AEP)

 3-095-005-42 (THAI, MALAY) (E)

 3-095-005-52 (TURKISH, GREEK) (AEP)

 3-095-005-62 (ENGLISH, SPANISH) (US)

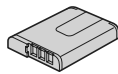

Rechargeable Battery Pack  
NP-BG1  
(Note)

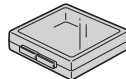

Battery Case  
(Note)



Wrist Strap  
2-050-981-01

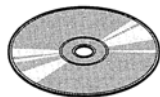

CD-ROM

(Cyber-shot Application Software/  
"Cyber-shot Handbook"/  
"Cyber-shot Step-up Guide")

 3-094-911-02 (EXCEPT US)

~~3-196-435-01 (US)~~



Cyber-shot Handbook (PDF)

The CD-ROM supplied contains all of language version of the Handycam Handbook (PDF) for printing.

- The printed matter is not supplied. If required, please order it with the part number below.

- (Only for destination Japanese model)

日本国内については日本語のみが印刷での部品供給可能です。

 3-094-994-02 (JAPANESE)

 3-094-994-12 (ENGLISH)

 3-094-994-22 (FRENCH)

 3-094-994-32 (ITALIAN)

 3-094-994-42 (SPANISH)

 3-094-994-52 (PORTUGUESE)

 3-094-994-62 (GERMAN)

 3-094-994-72 (DUTCH)

 3-094-994-82 (TRADITIONAL CHINESE)

 3-094-994-92 (SIMPLIFIED CHINESE)

 3-094-995-12 (RUSSIAN)

 3-094-995-22 (ARABIC)

 3-094-995-32 (PERSIAN)

 3-094-995-42 (KOREAN)

 3-094-995-52 (POLISH)

 3-094-995-62 (CZECH)

 3-094-995-72 (HUNGARIAN)

 3-094-995-82 (SLOVAK)

 3-094-995-92 (SWEDISH)

 3-094-996-12 (FINNISH)

 3-094-996-22 (NORWEGIAN)

 3-094-996-32 (DANISH)

 3-094-996-42 (THAI)

 3-094-996-52 (MALAY)

 3-094-996-62 (TURKISH)

 3-094-996-72 (GREEK)

## HARDWARE LIST (1/4)

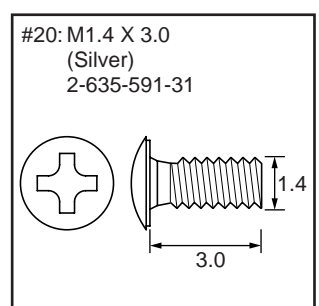
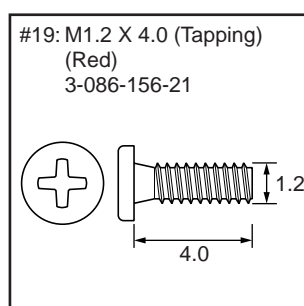
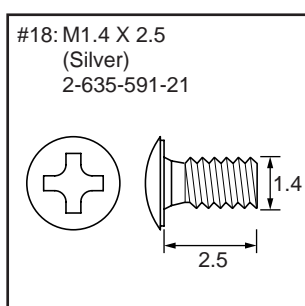
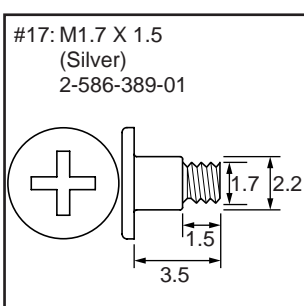
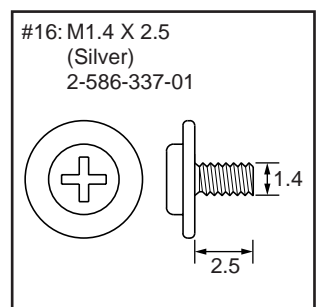
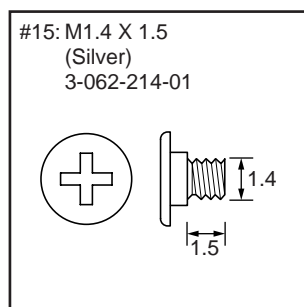
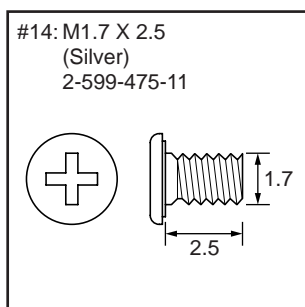
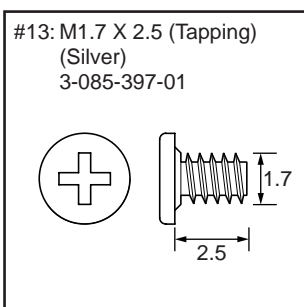
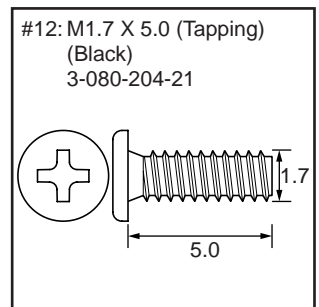
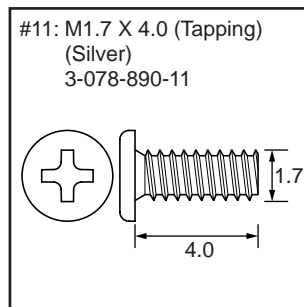
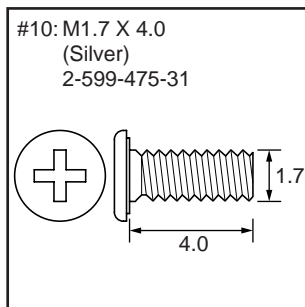
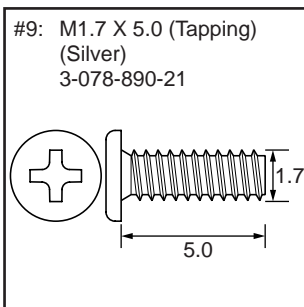
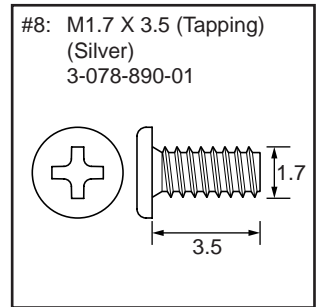
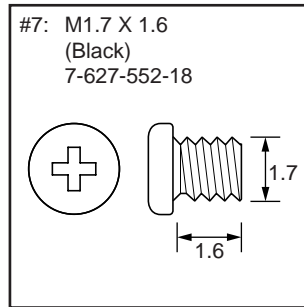
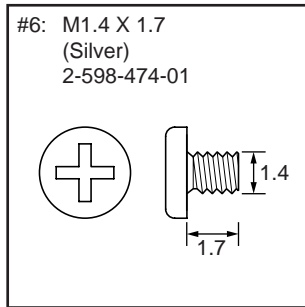
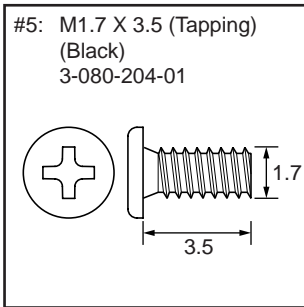
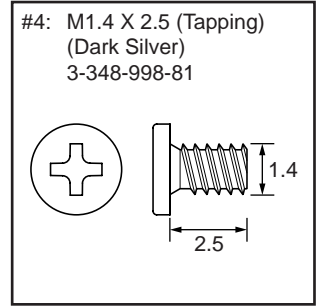
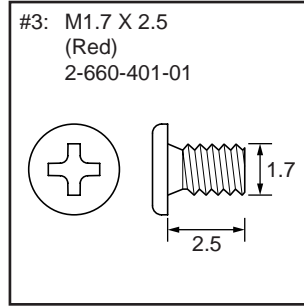
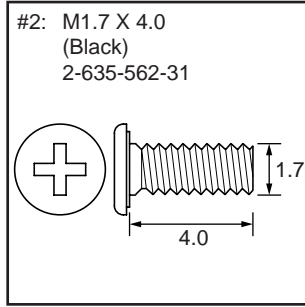
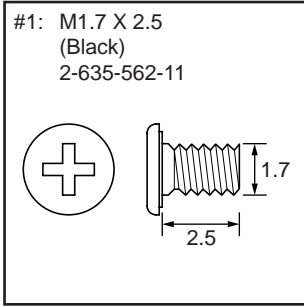

## HARDWARE LIST (2/4)

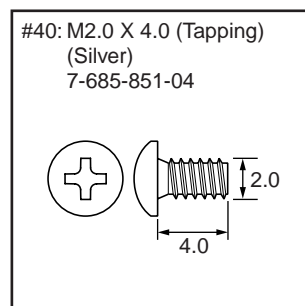
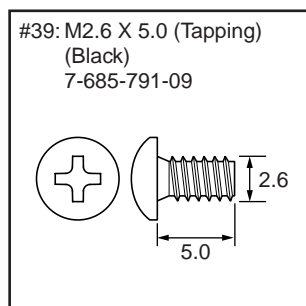
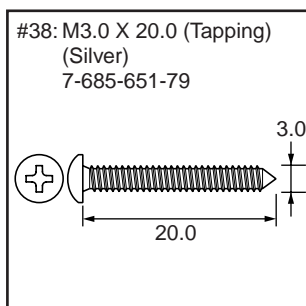
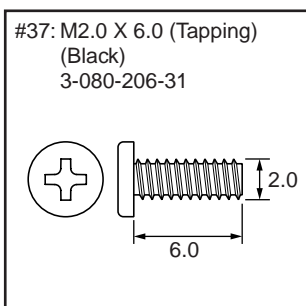
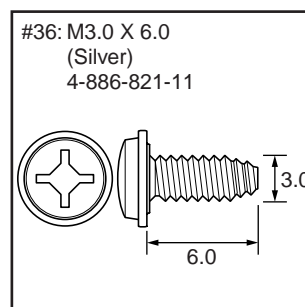
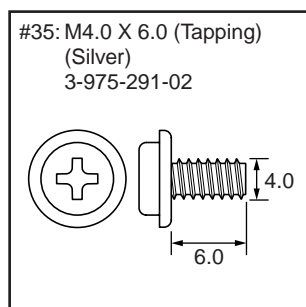
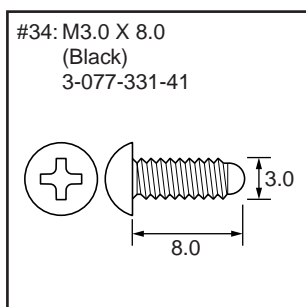
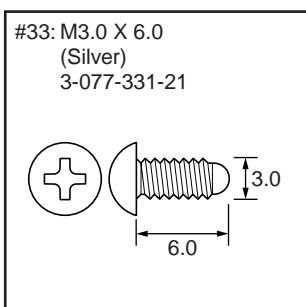
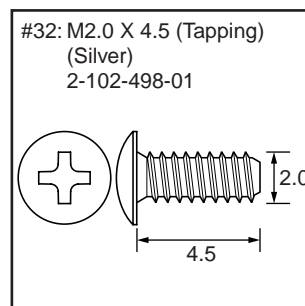
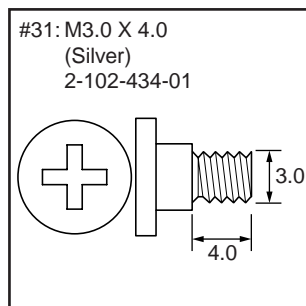
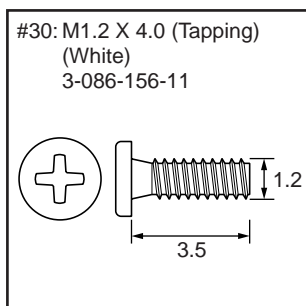
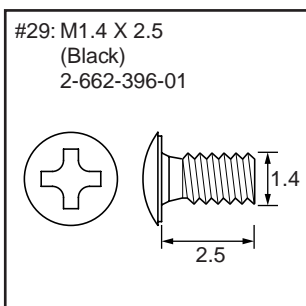
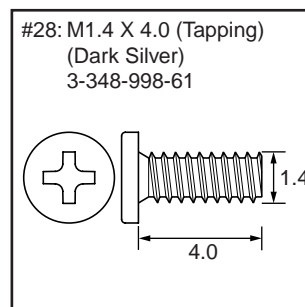
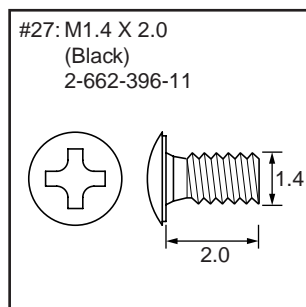
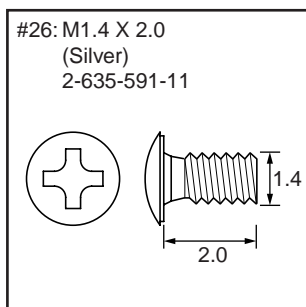
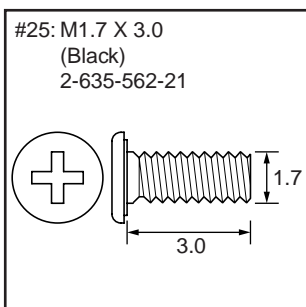
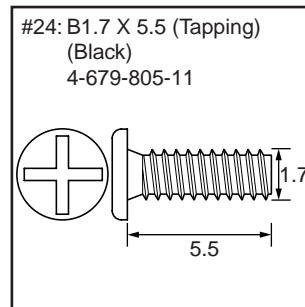
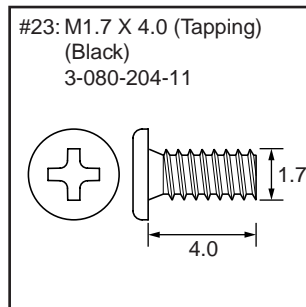
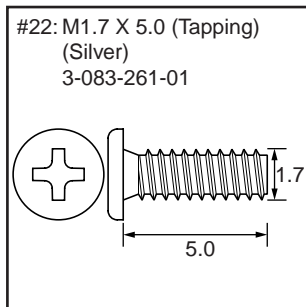
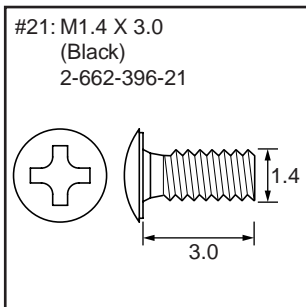

# HARDWARE LIST (3/4)

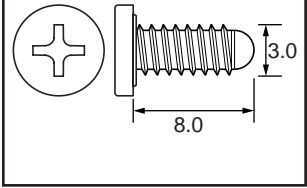
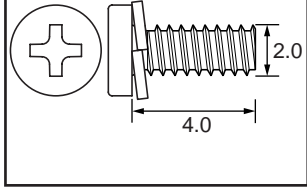
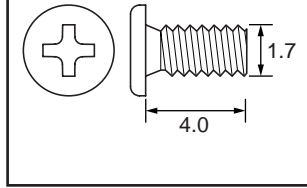
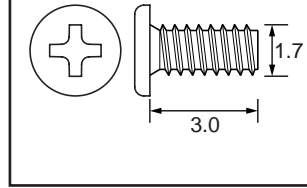
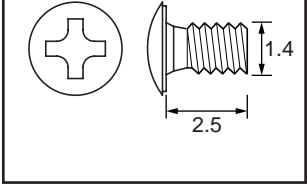
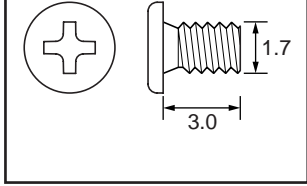
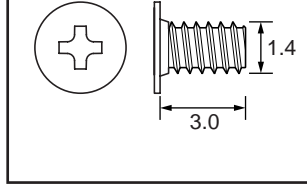
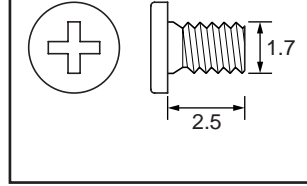
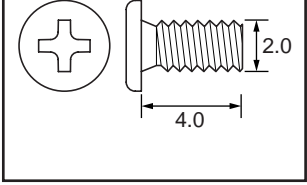
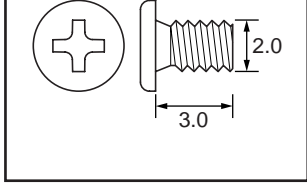
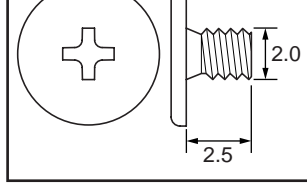
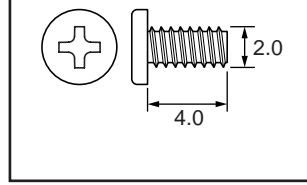
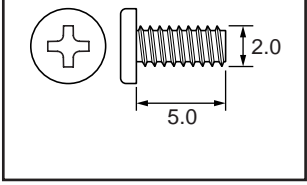
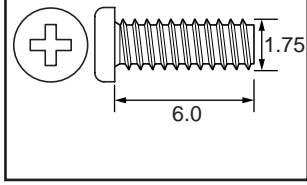
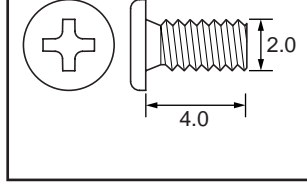
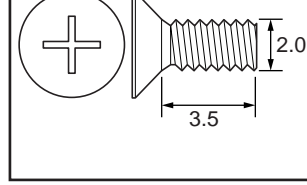
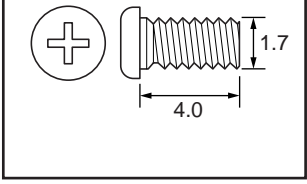
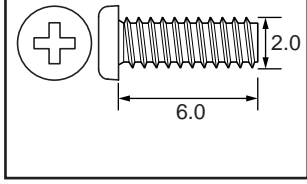
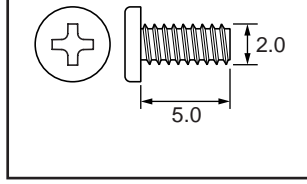
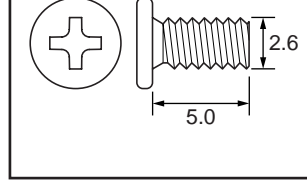
<p>#41: M3.0 X 8.0 (Tapping) (Silver) 3-065-748-01</p> 	<p>#42: M2.0 X 4.0 (Tapping) (Silver) 7-628-253-00</p> 	<p>#43: M1.7 X 4.0 (Red) 2-660-401-31</p> 	<p>#44: M1.7 X 3.0 (Tapping) (Silver) 3-078-890-61</p> 
<p>#45: M1.4 X 2.5 (Silver) 2-587-151-01</p> 	<p>#46: M1.7 X 3.0 (Red) 2-660-401-11</p> 	<p>#47: M1.4 X 3.0 (Tapping) (Silver) 2-665-774-01</p> 	<p>#48: M1.7 X 2.5 (Silver) 3-973-497-91</p> 
<p>#49: M2.0 X 4.0 (Black) 2-630-005-31</p> 	<p>#50: M2.0 X 3.0 (Red) 2-891-494-11</p> 	<p>#51: M2.0 X 2.5 (Silver) 3-073-686-01</p> 	<p>#52: M2.0 X 4.0 (Tapping) (Black) 3-080-206-11</p> 
<p>#53: M2.0 X 5.0 (Tapping) (Black) 3-080-206-21</p> 	<p>#54: M1.75 X 6.0 (Tapping) (Black) 3-318-203-11</p> 	<p>#55: M2.0 X 4.0 (Silver) 2-655-582-11</p> 	<p>#56: M2.0 X 3.5 (Silver) 3-067-187-11</p> 
<p>#57: M1.7 X 4.0 (Black) 7-627-852-18</p> 	<p>#58: M2.0 X 6.0 (Tapping) (Silver) 3-719-408-11</p> 	<p>#59: M2.0 X 5.0 (Tapping) (Silver) 3-080-205-21</p> 	<p>#60: M2.6 X 5.0 (Black) 3-061-062-11</p> 

# HARDWARE LIST (4/4)

#61: M3.0 X 10.0  
(Black)  
7-682-549-09

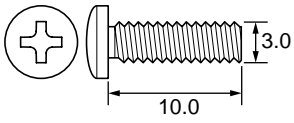

#62: M2.0 X 3.0  
(Silver)  
3-080-202-21

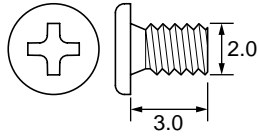

#63: M5.0 X 12.5  
(Black)  
3-060-811-21

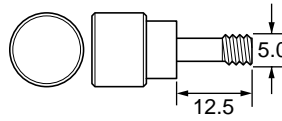

#64: M1.7 X 5.0 (Tapping)  
(Silver)  
2-666-551-21

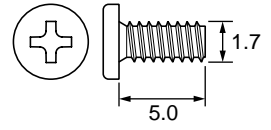

#65: M1.4 X 3.5  
(Silver)  
2-635-591-01

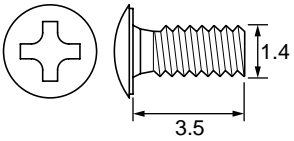

#66: M1.4 X 1.4  
(Silver)  
2-635-591-41

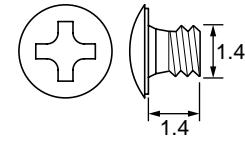

#67: M1.4 X 2.0  
(Silver)  
3-389-523-16

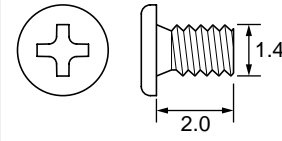

#68: M1.7 X 4.0  
(Silver)  
2-655-581-01

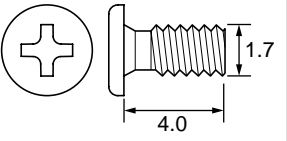

#69: M1.7 X 3.0  
(Silver)  
2-599-475-21

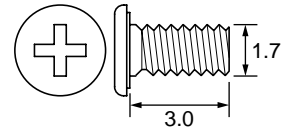

#70: M1.7 X 5.0  
(Silver)  
2-599-475-41

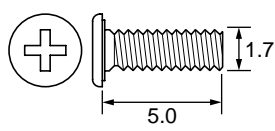

#71: M1.4 X 2.0  
(Red)  
3-208-537-01

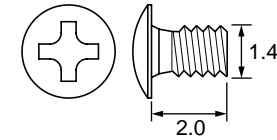

## About this service manual

For the promotion of browse in the PDF format, the "TABLE OF CONTENTS" was eliminated. As an alternative means, use a conventional function, "Bookmark". It will help you search/display not all pages but the desired page. In addition, the page layout was changed so that each page is positioned in the center to improve the visibility on the screen.

In the circuit diagram section, the symbols (such as @001) indicating internal connections of the divided circuit diagrams were eliminated. As an alternative function, the "Signal Location" is added. Except "GND", the divided signal names are listed in alphabetical order for easy search of the divided circuit diagrams (division numbers) and addresses.

### Example:

**4-2. SCHEMATIC DIAGRAMS**

**4-3. SIGNAL LOCATION**

**SY-169 BOARD**

1.2V_INT	(8/11)	D-11		(4/11)	E-4	EVER_
A_3.0V	(10/11)	E-11	CAM_12V	(1/11)	F-12	FC_DII
	(2/11)	C-10	CAM_3.5V	(10/11)	C-11	FC_DII
	(3/11)	E-2		(1/11)	C-10	
	(4/11)	A-6	CAM_7.5V	(5/11)	A-8	FC_EN
	(4/11)	A-9		(5/11)	D-8	
	(4/11)	B-6	CAMDD_EN	(1/11)	G-12	FC_SE
	(4/11)	B-9		(10/11)	D-11	
	(4/11)	C-2	CLK_IC_503	(8/11)	G-3	GEAR_
	(4/11)	E-6		(10/11)	E-2	
	(4/11)	F-6		(3/11)	B-2	
	(7/11)	B-1		(4/11)	C-1	

Address  
Division number  
Signal name

Of course, you can find the desired location by entering the signal name using the search function of the Acrobat, but it will take time to locate the one you want because the same words exist to and fro in the service manual.

In the PWB drawing section, the "MOUNTED PARTS LOCATION" was eliminated. To check the mounted part location, look at the enlarged view of the printed wiring board on which the desired part is mounted and enter the reference number for search with the Acrobat search function. If the corresponding part is found, it is highlighted and displayed in the center of the screen.

## Revision History

Ver.	Date	History	Contents	S.M. Rev. issued
1.0	2007.02	Official Release	—	—
1.1	2007.04	Revised-1	<ul style="list-style-type: none"> <li>• Style change of SCHEMATIC DIAGRAMS and PRINTED WIRING BOARDS</li> <li>• Change of part information of IC004 on the CD-694 flexible board</li> <li>• Change from “How to use Acrobat Reader” to “About this service manual”</li> <li>• Change of Checking supplied accessories</li> </ul>	Yes
1.2	2007.07	<a href="#">Supplement-1</a> (S1 DI07-042)	<ul style="list-style-type: none"> <li>• Change of Repair Parts</li> <li>• Change of Board’s Suffix No.</li> <li>• Correction of a capacitor unit</li> </ul> S.M. correction: <a href="#">Page 5-7</a>	Yes