

# DSC-W80/W85

## SERVICE MANUAL

LEVEL 2

Ver. 1.2 2009.03

Revision History

How to use  
Acrobat Reader

Internal memory  
ON BOARD

Revised-1

Replacement of the previously issued  
SERVICE MANUAL 9-852-194-31  
with this manual.



Photo: Silver

US Model  
Canadian Model  
AEP Model  
UK Model  
E Model  
Australian Model  
Hong Kong Model  
Chinese Model  
Korea Model  
Argentine Model  
Brazilian Model  
Japanese Model  
Tourist Model

### Link

<a href="#">SPECIFICATIONS</a>	<a href="#">DISASSEMBLY</a>	<a href="#">SCHEMATIC DIAGRAMS</a>
<a href="#">MODEL INFORMATION TABLE</a>	<a href="#">BLOCK DIAGRAMS</a>	<a href="#">PRINTED WIRING BOARDS</a>
<a href="#">SERVICE NOTE</a>	<a href="#">FRAME SCHEMATIC DIAGRAM</a>	<a href="#">REPAIR PARTS LIST</a>

#### • Precaution on Replacing the SY-173 Board

The components identified by mark  $\Delta$  or dotted line with mark  $\Delta$  are critical for safety. Replace only with part number specified.

Les composants identifiés par une marque  $\Delta$  sont critiques pour la sécurité. Ne les remplacer que par une pièce portant le numéro spécifié.

DIGITAL STILL CAMERA

SONY®



Cyber-shot



## SPECIFICATIONS

### Camera

#### [System]

Image device:

7.20 mm (1/2.5 type) color CCD,

Primary color filter

Total pixel number of camera:

Approx. 7 410 000 pixels

Effective pixel number of camera:

Approx. 7 201 000 pixels

Lens: Carl Zeiss Vario-Tessar 3× zoom lens f =

5.8 – 17.4 mm (35 – 105 mm when converted

to a 35 mm still camera) F2.8 – 5.2

Exposure control: Automatic exposure, Scene

Selection (7 modes)

White balance: Automatic, Daylight, Cloudy,

Fluorescent 1,2,3, Incandescent, Flash

File format (DCF compliant):

Still images: Exif Ver. 2.21 JPEG compliant,

DPOF compatible

Movies: MPEG1 compliant (Monaural)

Recording media: Internal Memory (approx.

31 MB), “Memory Stick Duo”

Flash:Flash range (ISO sensitivity

(Recommended exposure Index) set to Auto):

approx. 0.2 to 3.3 m (7 7/8 inches to 10 feet

10 inches) (W)/approx. 0.4 to 1.8 m (1 foot

3 3/4 inches to 5 feet 10 7/8 inches) (T)

#### [Input and Output connectors]

Multi connector Video output

Audio output (Monaural)

USB communication

USB communication: Hi-Speed USB (USB 2.0 compliant)

#### [LCD screen]

LCD panel: 6.2 cm (2.5 type) TFT drive

Total number of dots: 115 200 (480 × 240) dots

#### [Power, general]

Power: Rechargeable battery pack NP-BG1, 3.6 V

AC-LS5K AC Adaptor (not supplied), 4.2 V

Power consumption (during shooting with the LCD screen on):

1.1 W

Operating temperature: 0 to 40°C (32 to 104°F)

Storage temperature: –20 to +60°C (–4 to +140°F)

Dimensions: 91.0 × 58.0 × 22.9 mm (3 5/8 × 2 3/8 × 29/32 inches) (W/H/D, excluding protrusions)

Mass:

DSC-W80:

Approx. 155 g (5.5 oz) (including NP-BG1 battery pack and strap, etc.)

DSC-W85:

Approx. 166 g (5.9 oz) (including NP-BG1 battery pack and strap, etc.)

Microphone: Monaural

Speaker: Monaural

Exif Print: Compatible

PRINT Image Matching III: Compatible

PictBridge: Compatible

#### BC-CSG/BC-CSGB/BC-CSGC battery charger

Power requirements: AC 100 to 240 V, 50/60 Hz, 2 W (BC-CSG/BC-CSGC)/ 2.6 W (BC-CSGB)

Output voltage: DC 4.2 V, 0.25 A

Operating temperature: 0 to 40°C (32 to 104°F)

Storage temperature: –20 to +60°C (–4 to +140°F)

Dimensions: Approx. 62 × 24 × 91 mm (2 1/2 × 31/32 × 3 5/8 inches) (W/H/D)

Mass: Approx. 75 g (2.7 oz)

#### Rechargeable battery pack NP-BG1

Used battery: Lithium-ion battery

Maximum voltage: DC 4.2 V

Nominal voltage: DC 3.6 V

Capacity: 3.4 Wh (960 mAh)

Design and specifications are subject to change without notice.

## Model information table

Model	DSC-W80/Silver	DSC-W80/Black	DSC-W80/White	DSC-W80/Pink	DSC-W85/Silver
Destination	US, CND, AEP, UK, E, AUS, HK, CH, KR, AR, BR, J, JE	US, CND, AEP, UK, E, AUS, HK, CH, KR, JE	US, CND, AEP, UK, E, AUS, HK, CH, KR, J, JE	US, CND, AEP, UK, E, AUS, HK, CH, KR, J, JE	CND, AEP, UK, E, AUS, KR

- Abbreviation
  - AR : Argentine model
  - AUS : Australian model
  - BR : Brazilian model
  - CH : Chinese model
  - CND : Canadian model
  - EE : East European model
  - HK : Hong Kong model
  - J : Japanese model
  - JE : Tourist model
  - KR : Korea model
  - NE : North European model

### CAUTION

Danger of explosion if battery is incorrectly replaced.  
Replace only with the same or equivalent type.

### SAFETY-RELATED COMPONENT WARNING!!

**COMPONENTS IDENTIFIED BY MARK  $\triangle$  OR DOTTED LINE WITH MARK  $\triangle$  ON THE SCHEMATIC DIAGRAMS AND IN THE PARTS LIST ARE CRITICAL TO SAFE OPERATION. REPLACE THESE COMPONENTS WITH SONY PARTS WHOSE PART NUMBERS APPEAR AS SHOWN IN THIS MANUAL OR IN SUPPLEMENTS PUBLISHED BY SONY.**

### ATTENTION AU COMPOSANT AYANT RAPPORT À LA SÉCURITÉ!

**LES COMPOSANTS IDENTIFIÉS PAR UNE MARQUE  $\triangle$  SUR LES DIAGRAMMES SCHÉMATIQUES ET LA LISTE DES PIÈCES SONT CRITIQUES POUR LA SÉCURITÉ DE FONCTIONNEMENT. NE REMPLACER CES COMPOSANTS QUE PAR DES PIÈCES SONY DONT LES NUMÉROS SONT DONNÉS DANS CE MANUEL OU DANS LES SUPPLÉMENTS PUBLIÉS PAR SONY.**

## SAFETY CHECK-OUT

After correcting the original service problem, perform the following safety checks before releasing the set to the customer.

1. Check the area of your repair for unsoldered or poorly-soldered connections. Check the entire board surface for solder splashes and bridges.
2. Check the interboard wiring to ensure that no wires are "pinched" or contact high-wattage resistors.
3. Look for unauthorized replacement parts, particularly transistors, that were installed during a previous repair. Point them out to the customer and recommend their replacement.
4. Look for parts which, through functioning, show obvious signs of deterioration. Point them out to the customer and recommend their replacement.
5. Check the B+ voltage to see it is at the values specified.
6. FLEXIBLE Circuit Board Repairing
  - Keep the temperature of the soldering iron around 270°C during repairing.
  - Do not touch the soldering iron on the same conductor of the circuit board (within 3 times).
  - Be careful not to apply force on the conductor when soldering or unsoldering.

### Unleaded solder

Boards requiring use of unleaded solder are printed with the lead-free mark (LF) indicating the solder contains no lead. (Caution: Some printed circuit boards may not come printed with the lead free mark due to their particular size.)



### : LEAD FREE MARK

Unleaded solder has the following characteristics.

- Unleaded solder melts at a temperature about 40°C higher than ordinary solder. Ordinary soldering irons can be used but the iron tip has to be applied to the solder joint for a slightly longer time. Soldering irons using a temperature regulator should be set to about 350°C. Caution: The printed pattern (copper foil) may peel away if the heated tip is applied for too long, so be careful!
- Strong viscosity. Unleaded solder is more viscous (sticky, less prone to flow) than ordinary solder so use caution not to let solder bridges occur such as on IC pins, etc.
- Usable with ordinary solder. It is best to use only unleaded solder but unleaded solder may also be added to ordinary solder.

## TABLE OF CONTENTS

<u>Section</u>	<u>Title</u>	<u>Page</u>
<b>1. SERVICE NOTE</b>		
1-1.	Precaution on Replacing the SY-173 Board .....	1-1
1-2.	Self-diagnosis Function .....	1-1
1-3.	Process After Fixing Flash Error .....	1-2
1-4.	Method for Copying or Erasing the Data in Internal Memory .....	1-3
1-5.	How to Write Data to Internal Memory .....	1-4
<b>2. DISASSEMBLY</b>		
2-1.	Identifying Parts .....	2-2
2-2.	Disassembly .....	2-3
2-3.	Exchange method of barrier block .....	2-6
2-4.	Exchange method of zoom gear block .....	2-8
<b>3. BLOCK DIAGRAMS</b>		
3-1.	Overall Block Diagram (1/2) .....	3-1
3-2.	Overall Block Diagram (2/2) .....	3-2
3-3.	Power Block Diagram (1/2) .....	3-3
3-4.	Power Block Diagram (2/2) .....	3-4
<b>4. PRINTED WIRING BOARDS AND SCHEMATIC DIAGRAMS</b>		
4-1.	Frame Schematic Diagram .....	4-1
4-2.	Schematic Diagrams .....	4-3
4-3.	Printed Wiring Boards .....	4-21
4-4.	Mounted Parts Location .....	4-31
<b>5. REPAIR PARTS LIST</b>		
5-1.	Exploded Views .....	5-2
5-2.	Electrical Parts List .....	5-7

1-1. PRECAUTION ON REPLACING THE SY-173 BOARD

**DESTINATION DATA**

When you replace to the repairing board, the written destination data of repairing board also might be changed to original setting. Refer to Service Manual ADJ, and perform “DESTINATION DATA WRITE”.

**USB SERIAL No.**

The set is shipped with a unique ID (USB Serial No.) written in it. This ID has not been written in a new board for service, and therefore it must be entered after the board replacement. Refer to Service Manual ADJ, and perform “USB SERIAL No. INPUT”.

1-2. SELF-DIAGNOSIS FUNCTION

**1-2-1. Self-diagnosis Function**

When problems occur while the unit is operating, the self-diagnosis function starts working, and displays on the LCD screen what to do. Details of the self-diagnosis functions are provided in the Instruction manual.

**1-2-2. Self-diagnosis Display**

When problems occur while the unit is operating, the LCD screen shows a 4-digit display consisting of an alphabet and numbers, which blinks at 3.2 Hz. This 5-character display indicates the “repaired by:”, “block” in which the problem occurred, and “detailed code” of the problem.

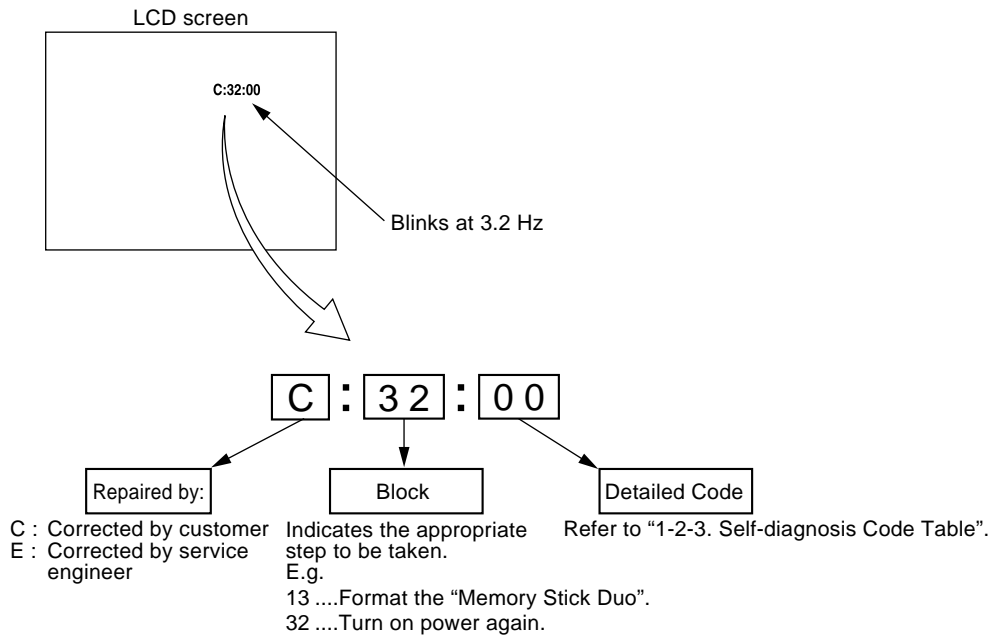

### 1-2-3. Self-diagnosis Code Table

Self-diagnosis Code				Symptom/State	Correction
Repaired by:	Block Function	Detailed Code			
C	1 3	0 1		The internal memory has experienced a format error.	Format the internal memory.
				“Memory Stick Duo” is unformatted.	Format the “Memory Stick Duo”.
				“Memory Stick Duo” is broken.	Insert a new “Memory Stick Duo”.
				“Memory Stick Duo” type error	Insert a supported “Memory Stick Duo”.
				The camera cannot read or write data on the “Memory Stick Duo”.	Turn the power off and on again, or taking out and inserting the “Memory Stick Duo” several times.
C	3 2	0 1		Trouble with hardware	Turn the power off and on again.
E	6 1	0 0		Difficult to adjust focus (Cannot initialize focus)	Retry turn the power on by the power switch. If it does not recover, check the focus reset sensor of lens block (pin ㉒ of CN402 on the SY-173 board). If it is OK, check the focus motor drive IC (IC401 on the SY-173 board).
E	6 1	1 0		Zoom operations fault (Cannot initialize zoom lens.)	Retry turn the power on by the power switch. Check the zoom reset sensor of lens block (pin ㉔ of CN402 on the SY-173 board), if zooming is performed when the zoom button is operated. If it is OK, check the zoom motor drive IC (IC401 on the SY-173 board).
E	6 2	0 2		Abnormality of IC for steadyshot.	Check or replacement of the IC for steadyshot (IC503 on the SY-173 board).
E	6 2	1 0		Lens initializing failure.	Check or replacement of the IC for steadyshot (IC503 on the SY-173 board).
E	6 2	1 1		Lens overheating (PITCH).	Check the HALL element (PITCH) of optical image stabilizer (pin ㉕, ㉖ of CN402 on the SY-173 board). If it is OK, check PITCH angular velocity sensor (SE502 on the SY-173 board) peripheral circuits.
E	6 2	1 2		Lens overheating (YAW).	Check the HALL element (YAW) of optical image stabilizer (pin ㉗, ㉘ of CN402 on the SY-173 board). If it is OK, check YAW angular velocity sensor (SE501 on the SY-173 board) peripheral circuits.
E	6 2	2 0		Abnormality of thermistor.	Check the OIS temp sensor of optical image stabilizer (pin ㉙ of CN402 on the SY-173 board).
E	9 1	0 1		Abnormality when flash is being charged.	Checking of flash unit or replacement of flash unit. (Note)
E	9 2	0 0		Non-standard battery is used.	Use the compatible battery only.

**Note:** After repair, be sure to perform “1-3. PROCESS AFTER FIXING FLASH ERROR”.

### 1-3. PROCESS AFTER FIXING FLASH ERROR

When “FLASH error” (Self-diagnosis Code E : 91 : 01) occurs, to prevent any abnormal situation caused by high voltage, setting of the flash is changed automatically to disabling charge and flash setting.

After fixing, this setting needs to be deactivated. Flash error code can be initialized by the operations on the HOME screen.

#### Method for Initializing the Flash Error Code

##### Initialize

Initializes the setting to the default setting. Even if you execute this function, the images stored in the internal memory are retained.

- ① Select [Initialize] with ▲/▼/◀/▶, then press ●.  
The message “Initialize all settings” appears.
- ② Select [OK] with ▲, then press ●.  
The settings are reset to the default setting.

#### To cancel the resetting

Select [Cancel] in step ②, then press ●.

- Make sure that the power is not disconnected during resetting.

## 1-4. METHOD FOR COPYING OR ERASING THE DATA IN INTERNAL MEMORY

The data can be copied/erased by the operations on the HOME screen. (When erasing the data, execute formatting the internal memory.)

**Note 1:** When replacing the SY-173 board, erase the data in internal memory of the board before replacement.

**Note 2:** When replacing the SY-173 board, execute formatting and initialize the internal memory after replacement.

### Method for Copying the Data in Internal Memory

#### Copy

Copies all images in the internal memory to a “Memory Stick Duo”.

- ① Insert a “Memory Stick Duo” having 32 MB or larger capacity.
- ② Select [Copy] with ▲/▼/◀/▶ on the control button, then press ●.  
The message “All data in internal memory will be copied” appears.
- ③ Select [OK] with ▲, then press ●.  
Copying starts.

#### To cancel the copying

Select [Cancel] in step ③, then press ●.

- Use a fully charged battery pack. If you attempt to copy image files using a battery pack with little remaining charge, the battery pack may run out, causing copying to fail or possibly corrupting the data.
- You cannot copy individual images.
- The original images in the internal memory are retained even after copying. To delete the contents of the internal memory, remove the “Memory Stick Duo” after copying, then execute the [Format] command in [Internal Memory Tool].
- When you copy the data in the internal memory to the “Memory Stick Duo”, all the data will be copied. You cannot choose a specific folder on the “Memory Stick Duo” as the destination for the data to be copied.
- Even if you copy data, a **DPOF** (Print order) mark is not copied

### Method for Formatting the Internal Memory

This item does not appear when a “Memory Stick Duo” is inserted in the camera.

#### Format

Formats the internal memory.

- Note that formatting irrevocably erases all data in the internal memory, including even protected images.

- ① Select [Format] with ▲/▼/◀/▶ on the control button, then press ●.  
The message “All data in internal memory will be erased” appears.
- ② Select [OK] with ▲, then press ●.  
The format is completed.

#### To cancel the formatting

Select [Cancel] in step ②, then press ●.

## 1-5. HOW TO WRITE DATA TO INTERNAL MEMORY

Usually, the camera has been set so as to disable the data writing from the PC to the internal memory of the camera.

This setting must be changed temporarily when the data is to be written to the internal memory such as a case after the board replacement.

To change the setting, use the write enable tool “WriteEnableTool.exe”.

### Data writing method

- 1) Connect the PC to the camera (USB mode: Mass Storage), and switch the driver to the “Sony Seus USB Driver”.
- 2) Start the Write Enable Tool and the SeusEX.
- 3) Click the Activate Write Enable Mode button of the Write Enable Tool.

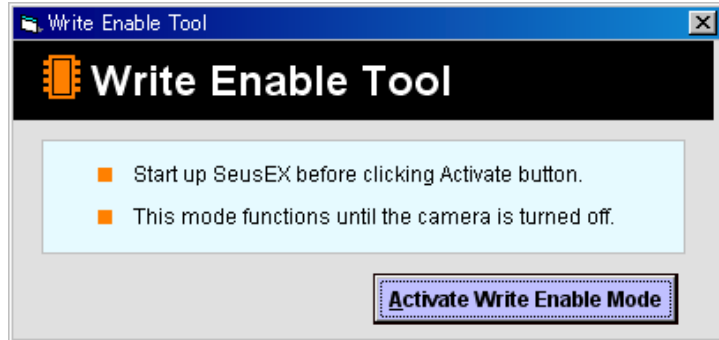

- 4) Upon completion of the setting change, the following message will be displayed.

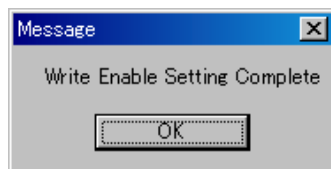

- 5) Return the driver to the original one, and connect the PC to the camera (USB mode: Mass Storage).
- 6) Write the data read out into the PC to the internal memory of the camera.
- 7) Disconnect the PC from the camera, and turn off the camera.

**Note:** By turning off the camera, the write enable setting is reset.

## 1-1. SY-173基板交換時の注意

## 仕向けデータ

補修用基板と交換する時、補修用基板に書かれている仕向けデータは元の設定と違う場合があります。ADJ編を参照して、「DESTINATION DATA WRITE」を行ってください。

## USBシリアルNo.

セットは、1台毎に異なる固有のID（USB Serial No.）を書き込んだ後、出荷されています。新品の補修用基板には、このIDが書き込まれていないので、基板交換後にIDを入力する必要があります。ADJ編を参照して、「USB SERIAL No. INPUT」を行ってください。

## 1-2. 自己診断機能

## 1-2-1. 自己診断機能について

本機の動作に不具合が生じたとき、自己診断機能が働き、LCD画面に、どう処置したらよいか判断できる表示を行います。自己診断機能については取扱説明書にも掲載されています。

## 1-2-2. 自己診断表示

本機の動作に不具合が生じたとき、LCD画面にアルファベットと4桁の数字が表示され、3.2Hzで点滅します。この5文字の表示によって対応者分類および不具合の生じたブロックの分類、不具合の詳細コードを示します。

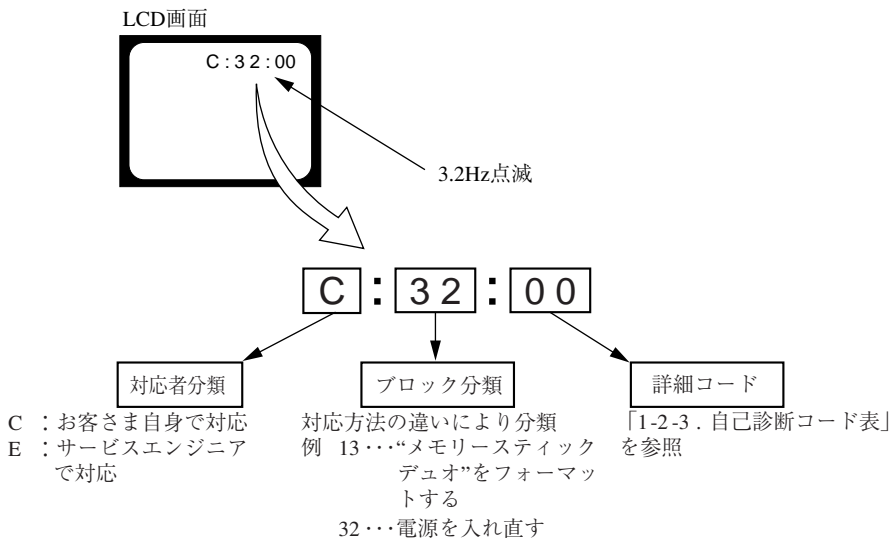

## 1-2-3. 自己診断コード表

自己診断コード				症状/状態	対応/方法
対応者	ブロック機能	詳細コード			
C	1 3	0 1		内蔵メモリにフォーマットエラーがあった。	内蔵メモリをフォーマットする。
				フォーマットしていない“メモリースティック デュオ”を入れた。	“メモリースティック デュオ”をフォーマットする。
				“メモリースティック デュオ”が壊れている。	新しい“メモリースティック デュオ”に交換する。
				“メモリースティック デュオ”のタイプエラーを検出した。	規格内の“メモリースティック デュオ”を挿入する。
				“メモリースティック デュオ”が読み/書きできない。	電源の入れ直し、または“メモリースティック デュオ”の挿し/外しを数回試す。
C	3 2	0 1		ハードウェアトラブルを検出した。	電源を入れ直す。
E	6 1	0 0		フォーカスが合いにくい。 (フォーカスの初期化ができない)	操作スイッチの電源を入れ直す。 復帰しない場合はレンズブロックのフォーカスリセットセンサ (SY-173基板CN402 ㉒ピン) を点検する。異常なければフォーカスマータ駆動IC (SY-173基板IC401) を点検する。
E	6 1	1 0		ズーム動作の異常。 (ズームレンズの初期化ができない)	操作スイッチの電源を入れ直す。 ズームボタンを操作したときにズーム動作をすればレンズブロックのズームリセットセンサ (SY-173基板CN402 ㉑ピン) を点検する。異常なければズームモータ駆動IC (SY-173基板IC401) を点検する。
E	6 2	0 2		手振れ補正用ICの異常。	手振れ補正用IC (SY-173基板IC503) を点検または交換する。
E	6 2	1 0		手振れ補正用ICの異常。 (レンズ初期化異常)	手振れ補正用IC (SY-173基板IC503) を点検または交換する。
E	6 2	1 1		レンズオーバーヒート (PITCH)	光学手振れ補正ブロックのホール素子 (PITCH) (SY-173基板CN402 ㉓, ㉔ピン) を点検する。異常なければPITCH角速度センサ (SY-173基板SE502) 周辺の回路を点検する。
E	6 2	1 2		レンズオーバーヒート (YAW)	光学手振れ補正ブロックのホール素子 (YAW) (SY-173基板CN402 ㉕, ㉖ピン) を点検する。異常なければYAW角速度センサ (SY-173基板SE501) 周辺の回路を点検する。
E	6 2	2 0		サーミスタの異常。	光学手振れ補正ブロックのサーミスタ (SY-173基板CN402 ㉗ピン) を点検する。
E	9 1	0 1		フラッシュの充電異常。	フラッシュユニットを点検または交換する。(Note)
E	9 2	0 0		規定外の充電電池が使用された。	規定の充電電池を使用する。

Note : 交換後は、必ず「1-3. フラッシュエラー発生時の対処法」を行って下さい。

### 1-3. フラッシュエラー発生時の対処法

本機はフラッシュエラー（自己診断コードE：91：01）が発生した場合、高電圧による異常を防止するために自動的にフラッシュ充電および発光禁止の設定になります。

フラッシュエラー発生後はエラーの解除を行う必要があります。エラーの解除はホーム画面から初期化操作を実行することにより行います。

#### 設定リセット

お買い上げ時の設定に戻します。  
[設定リセット]を実行しても、内蔵メモリーに記録されている画像は削除されません。

- ① コントロールボタンの▲/▼/◀/▶で[設定リセット]を選び、中央の●を押す。  
「全ての設定内容をリセットします」というメッセージが表示される。
- ② ▲で[実行]を選び、中央の●を押す。  
設定リセットが実行される。

#### 設定リセットを中止するには

手順②で、[キャンセル]を選び、中央の●を押す。

設定リセット中は電源が切れないようにご注意ください。

### 1-4. 内蔵メモリのデータコピーおよび消去方法

内蔵メモリのデータコピーまたは消去はホーム画面の操作から実行可能です。（消去する場合は内蔵メモリの初期化を行います。）

**Note1：**SY-173基板交換の際は、基板交換前に内蔵メモリのデータを消去して下さい。

**Note2：**SY-173基板交換の際は、基板交換後に内蔵メモリのフォーマットおよび初期化を実行して下さい。

### 内蔵メモリのコピー方法

#### コピー

内蔵メモリーに記録した画像を、“メモリースティック デュオ”に一括コピーします。

- ① 32MB以上の容量のある“メモリースティック デュオ”を本体に入れる。
- ② コントロールボタンの▲/▼/◀/▶で[コピー]を選び、中央の●を押す。  
「内蔵メモリーのデータがすべてコピーされます」というメッセージが表示される。
- ③ ▲で[実行]を選び、中央の●を押す。  
コピーが実行される。

#### コピーを中止するには

手順③で、[キャンセル]を選び、中央の●を押す。

十分に充電したバッテリーをご使用ください。残量の少ないバッテリーを使用して画像ファイルをコピーすると、バッテリー切れのためデータを転送できなかったり、データを破損するおそれがあります。

画像ごとのコピーはできません。

データをコピーしても、内蔵メモリー内のデータは削除されません。内蔵メモリーの内容を消去するには、コピー後に“メモリースティック デュオ”を本体から取りはずし、[内蔵メモリーツール]の[フォーマット]を行ってください。

データをコピーすると“メモリースティック デュオ”内に新しいフォルダが作成されます。コピー先のフォルダを指定することはできません。

データのコピーを行っても、DPOF(プリント予約)マークの設定はコピーされません。

### 内蔵メモリのフォーマット方法

“メモリースティック デュオ”が本機に入っている場合は表示されません。

#### フォーマット

内蔵メモリーの管理領域をフォーマット(初期化)します。

フォーマットすると、プロテクトしてある画像も含めて、すべてのデータが消去され、元に戻せません。

- ① コントロールボタンの▲/▼/◀/▶で[フォーマット]を選び、中央の●を押す。  
「内蔵メモリーのデータがすべて消去されます」というメッセージが表示される。
- ② ▲で[実行]を選び、中央の●を押す。  
フォーマットが実行される。

#### フォーマットを中止するには

手順②で、[キャンセル]を選び、中央の●を押す。

## 1-5. 内蔵メモリヘータを書き戻す方法

通常は、PCからカメラの内蔵メモリヘータを書き込むことはできない設定になっています。

基板交換後などに、内蔵メモリヘータを書き戻す場合には、この設定を一時的に変更する必要があります。

設定の変更には、書き込み許可ツール（WriteEnableTool.exe）を使用します。

### 書き戻し方法

- 1) カメラとPCをマスタストレージ接続し、ドライバを“Sony Seus USB Driver”に切り替える。
- 2) 書き込み許可ツールとSeusEXを起動する。
- 3) 書き込み許可ツールの[Activate Write Enable Mode]ボタンをクリックする。

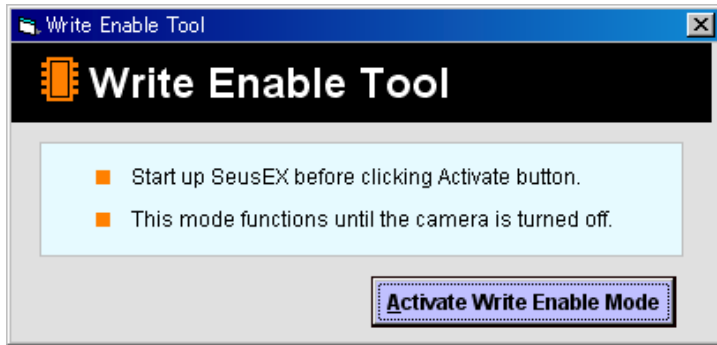

- 4) 設定の変更が終了すると、次のメッセージが表示されます。

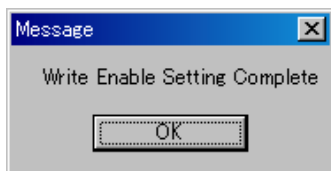

- 5) ドライバを元に戻して、カメラとPCをマスタストレージ接続する。
- 6) PCに読み出しておいたデータをカメラの内蔵メモリに書き込む。
- 7) カメラとPCの接続を解除し、カメラの電源をOFFにする。

注意：カメラの電源をOFFにすることにより、書き込み許可の設定が解除されます。

## 2. DISASSEMBLY

### NOTE FOR REPAIR

- Make sure that the flat cable and flexible board are not cracked or bent at the terminal.  
Do not insert the cable insufficiently nor crookedly.
- When remove a connector, don't pull at wire of connector. It is possible that a wire is snapped.
- When installing a connector, don't press down at wire of connector.  
It is possible that a wire is snapped.
- Do not apply excessive load to the gilded flexible board.

Cut and remove the part of gilt which comes off at the point.  
(Be careful or some pieces of gilt may be left inside)

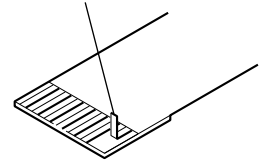

### DISCHARGING OF THE ST-160 BOARD'S CHARGING CAPACITOR (C901)

The charging capacitor (C901) of the ST-160 board is charged up to the maximum 300 V potential.

There is a danger of electric shock by this high voltage when the capacitor is handled by hand. The electric shock is caused by the charged voltage which is kept without discharging when the main power of the unit is simply turned off. Therefore, the remaining voltage must be discharged as described below.

#### Preparing the Short Jig

To preparing the short jig, a small clip is attached to each end of a resistor of 1 k $\Omega$  / 1 W (1-215-869-11).

Wrap insulating tape fully around the leads of the resistor to prevent electrical shock.

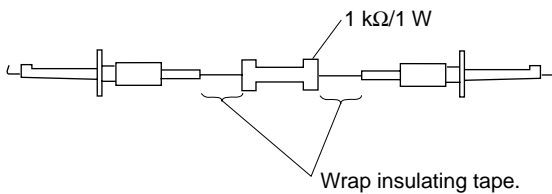

**Note: High-voltage cautions**

**Discharging the Capacitor**  
Short-circuit between the two points with the short jig about 10 seconds.

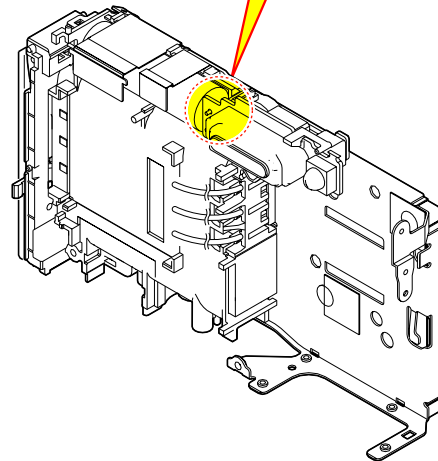
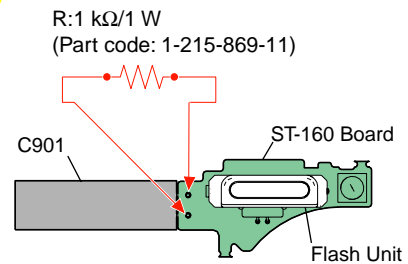

## 2-1. IDENTIFYING PARTS

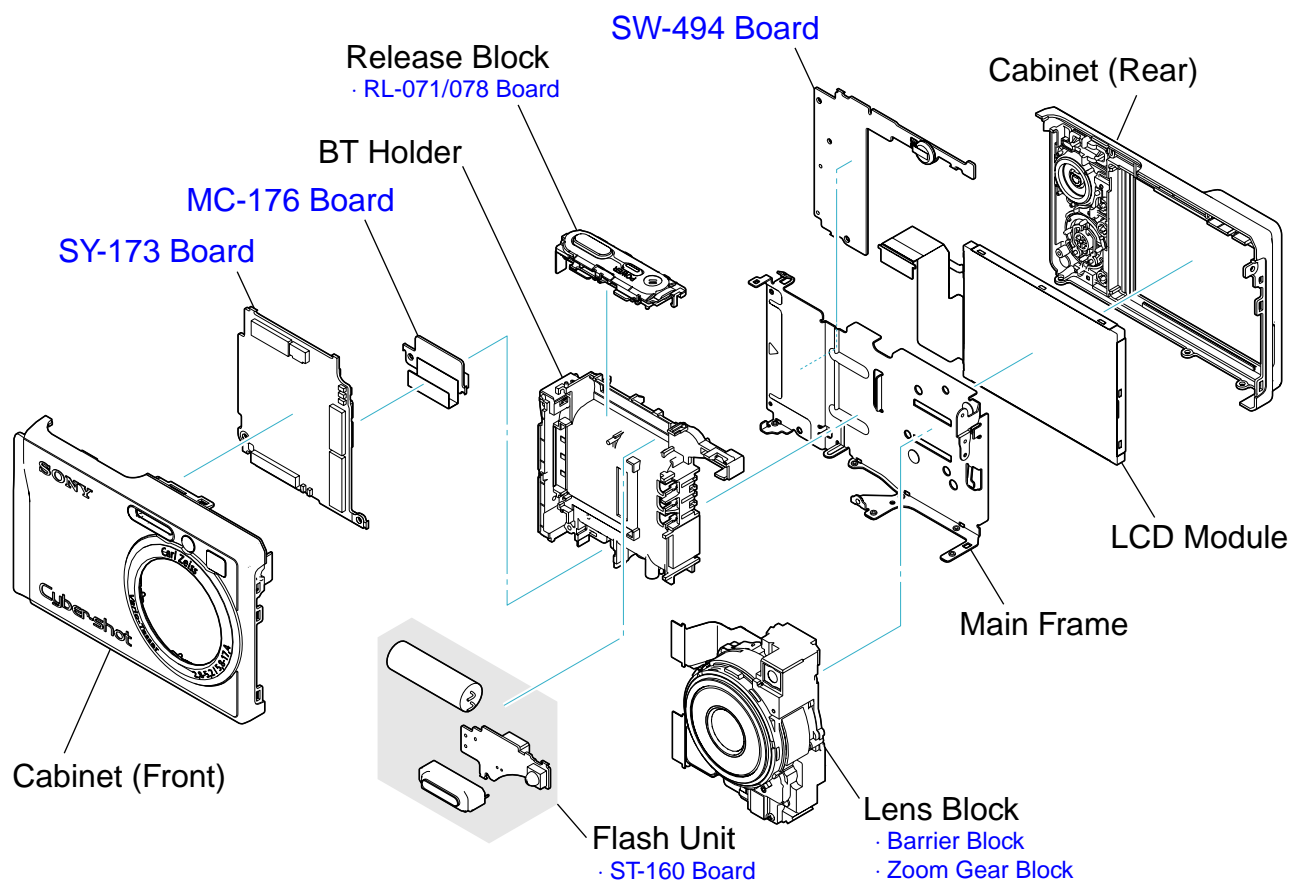

### - DISASSEMBLY FLOW -

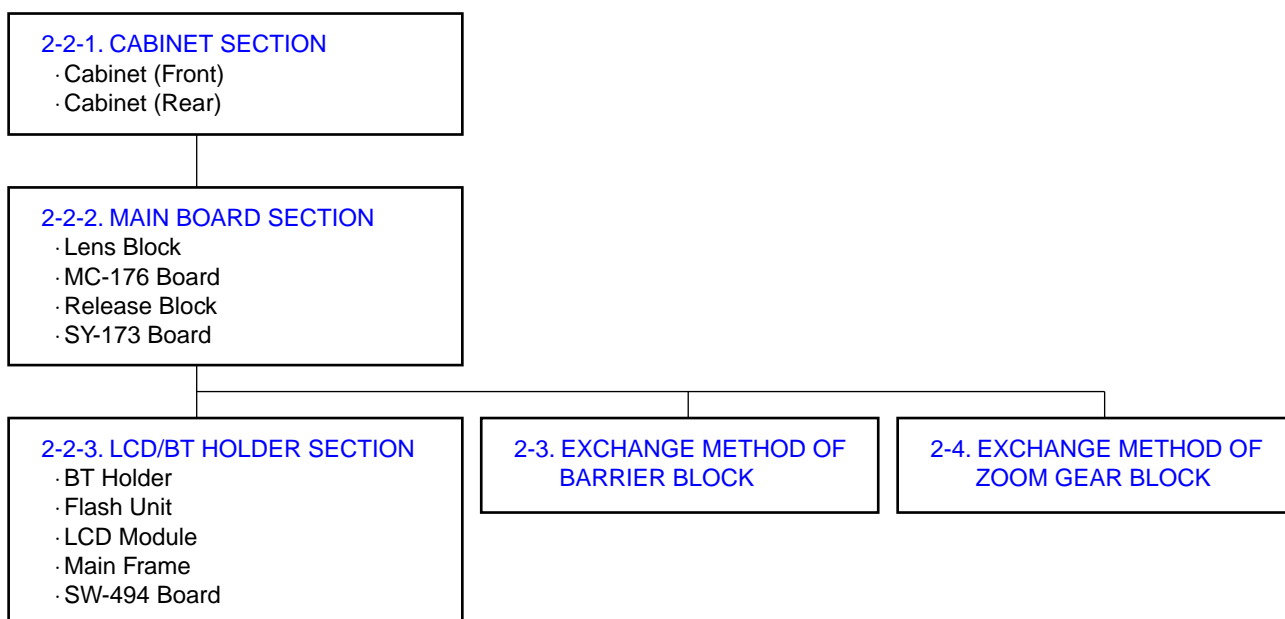

## 2-2. DISASSEMBLY

**EXPLODED VIEW**

**HARDWARE LIST**

### 2-2-1. CABINET SECTION

Follow the disassembly in the numerical order given.

- ① Cabinet (Front) (①-1 to ①-8)
- ② Cabinet (Rear) (②-1 to ②-2)

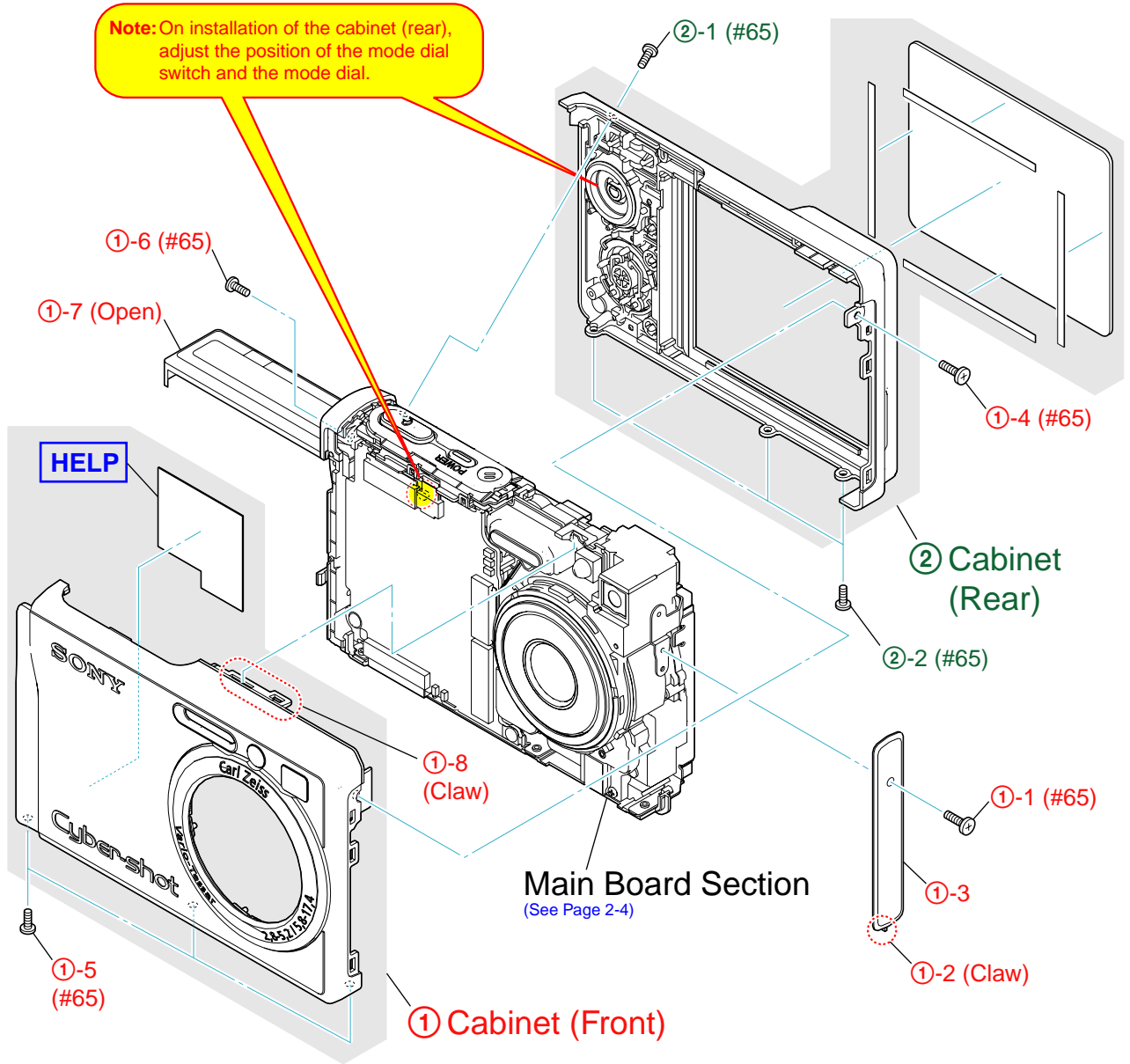

## 2-2-2. MAIN BOARD SECTION

Follow the disassembly in the numerical order given.

- ① Release Block (①-1 to ①-3)
- ② Lens Block (②-1 to ②-5)
- ③ SY-173 Board (③-1 to ③-11)

EXPLODED VIEW

HARDWARE LIST

**Note:** High-voltage cautions

### Discharging the Capacitor

Short-circuit between the two points with the short jig about 10 seconds.

R: 1 k $\Omega$ /1 W  
(Part code: 1-215-869-11)

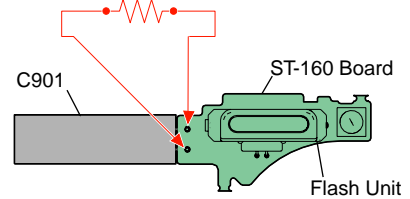

### LCD/BT Holder Section (See Page 2-5)

②-3  
(Release the claw that is the fixation of the flash unit once)

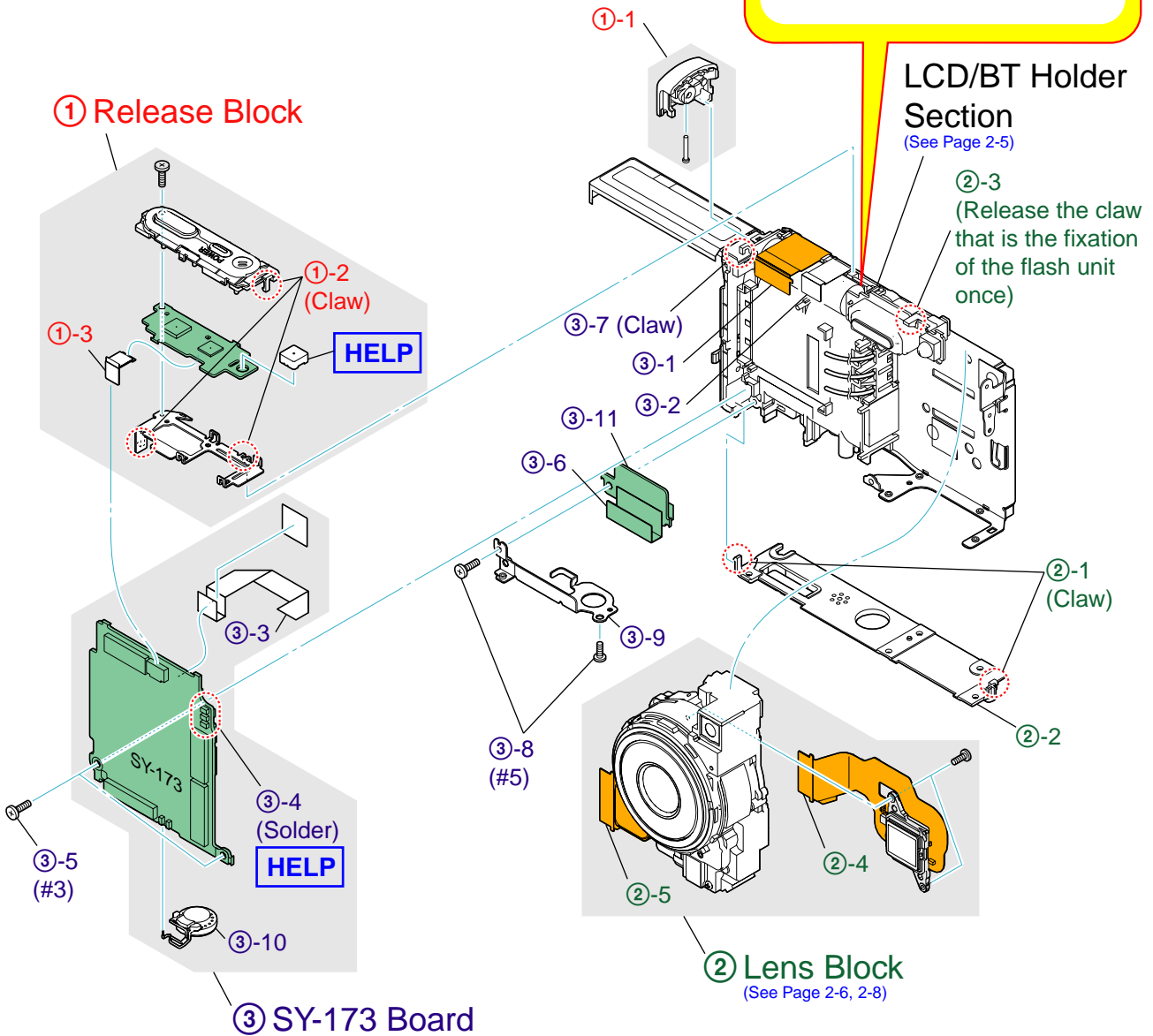

### 2-2-3. LCD/BT HOLDER SECTION

Follow the disassembly in the numerical order given.

- ① Flash Unit (①-1)
- ② LCD Panel/SW-494 Board (②-1 to ②-4)
- ③ BT Holder (③-1 to ③-3)

EXPLODED VIEW

HARDWARE LIST

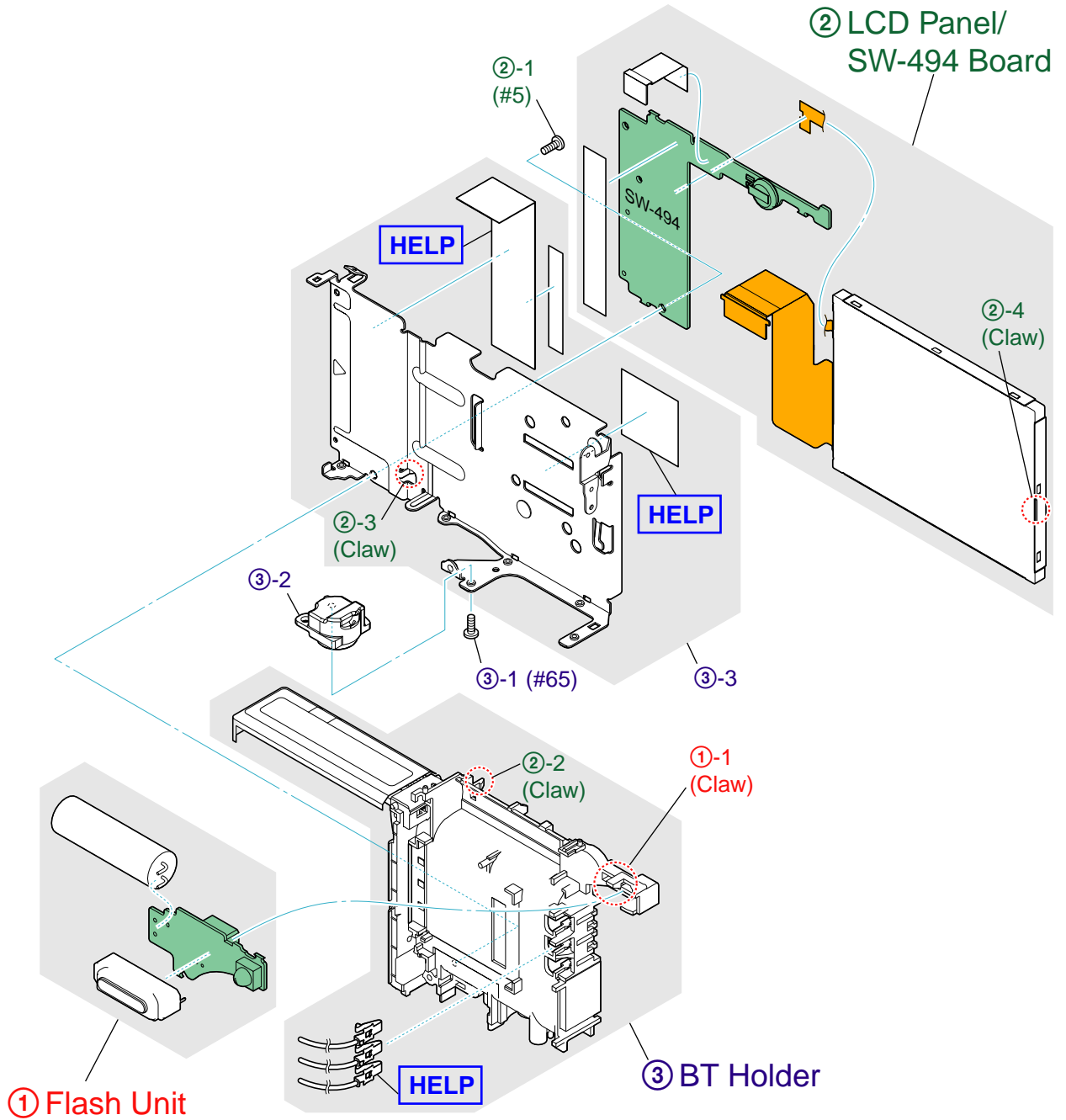

## 2-3. EXCHANGE METHOD OF BARRIER BLOCK

**Note:** Do not hold the part of spring.

### 2-3-1. HOW TO REMOVE THE ORNAMENTAL RING (A)

- ① Turn on the power switch.
- ② With the ornamental ring (A) extended, remove the battery forcibly.
- ③ Apply a solvent to the tweezers or a needle, and dissolve the adhesive on the barrier tapes that secure the ornamental ring (A) to the barrier block.
- ④ Rotate the ornamental ring (A) clockwise to remove.

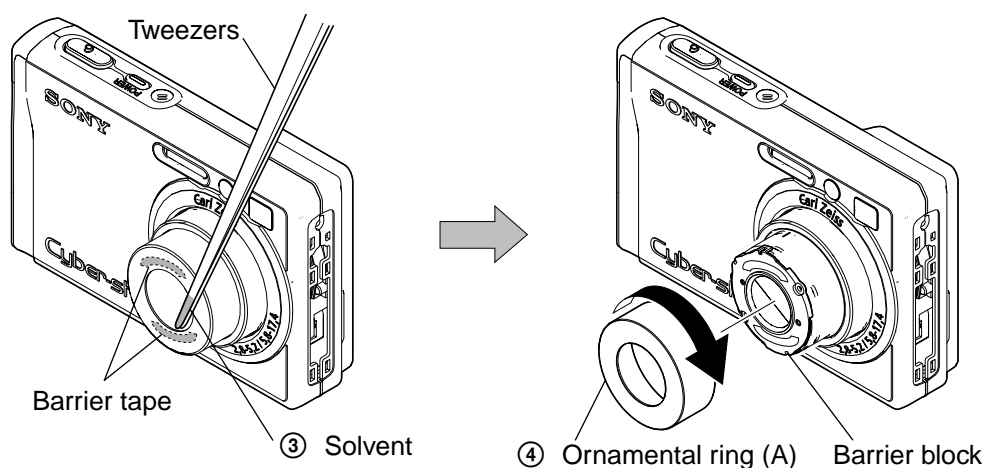

### 2-3-2. HOW TO REMOVE THE BARRIER BLOCK

- ① Remove two screws.
- ② Remove the barrier block and the inner ring.

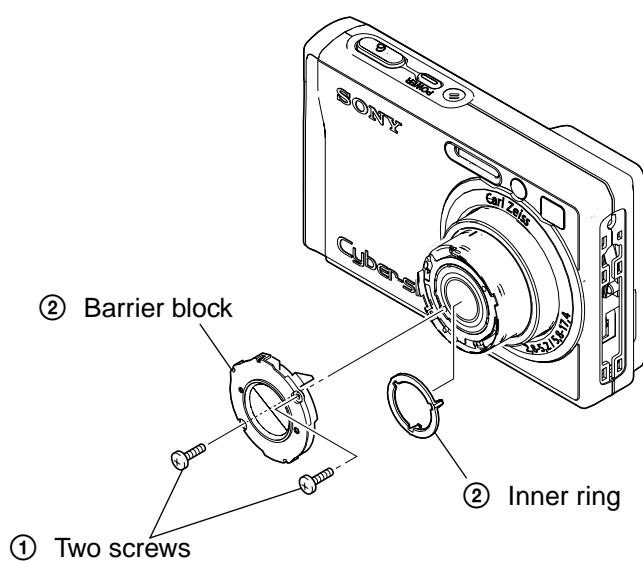

### 2-3-3. HOW TO INSTALL THE BARRIER BLOCK

- ① Install the inner ring and the barrier block.

**Note:** When installing the barrier block, the CAV No. must be located in the lower left position.

- ② Secure the barrier block with two screws.

\*Tightening torque =  $0.049 \pm 0.01\text{N} \cdot \text{m}$  ( $0.5 \pm 0.1\text{kgf} \cdot \text{cm}$ )

**Note:** Check that the barrier feather of the barrier block is not opened slightly or half-closed.

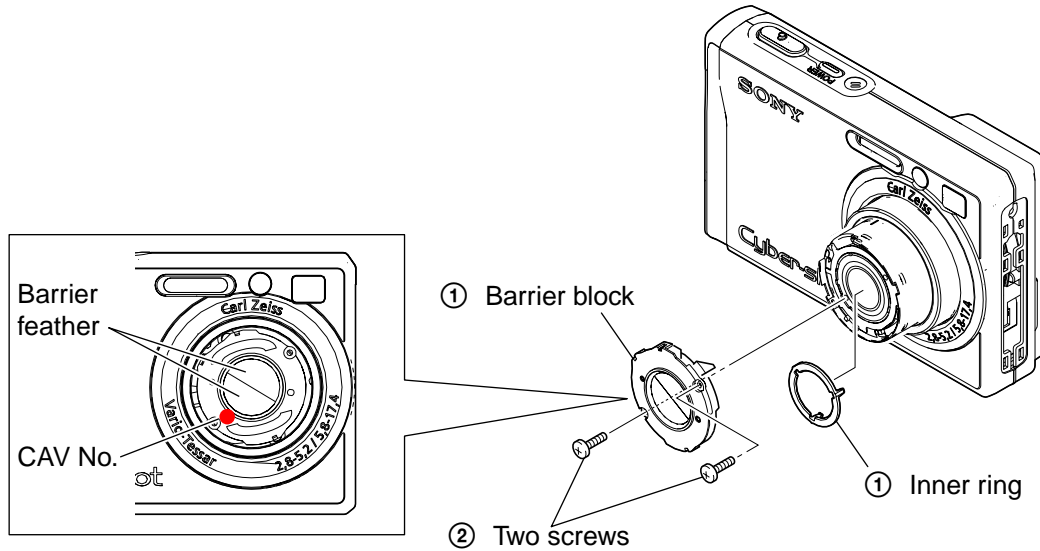

### 2-3-4. HOW TO INSTALL THE ORNAMENTAL RING (A)

- ① Affix two barrier tapes to the barrier block.

**Note:** The barrier tape must not cover the boss of the barrier block.

- ② Install the ornamental ring (A).

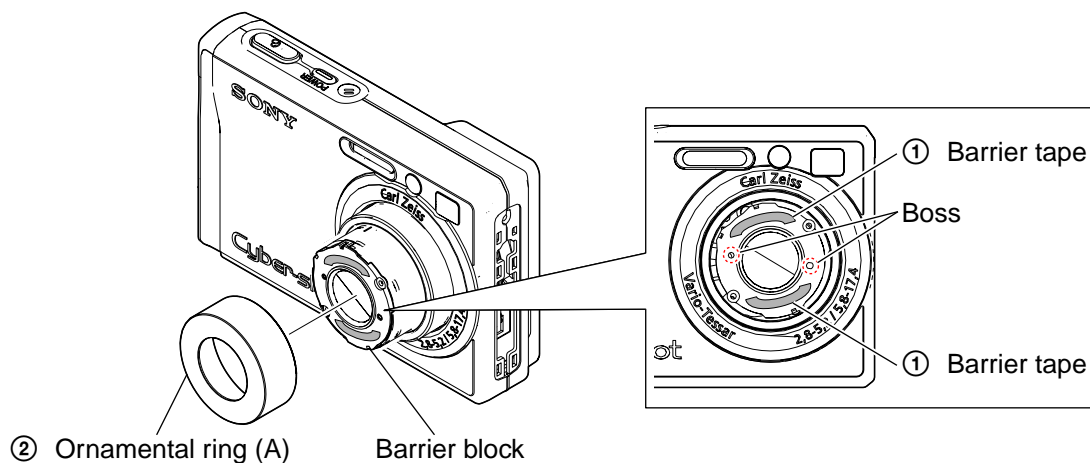

**Note:** Turn on and off the power to check the opening and closing of the barrier block with the camera in horizontal, up and down directions respectively.  
Further, check the zoom motion.  
Rotate the ornamental ring (A) lightly to check that it is not removed.

## 2-4. EXCHANGE METHOD OF ZOOM GEAR BLOCK

**Note:** Do not hold the part of terminal and the part of spring.

### 2-4-1. HOW TO REMOVE THE ZOOM GEAR BLOCK

#### • HOW TO REMOVE THE REAR ASSEMBLY

- ① Remove the screw, and then the OVF.

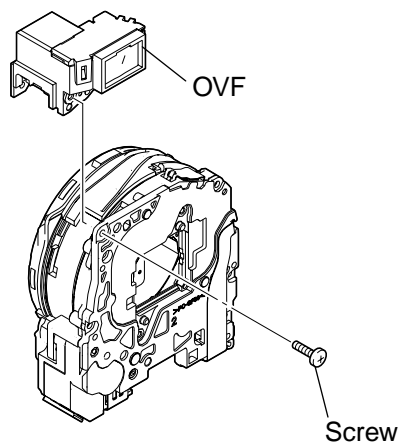

- ② Remove the shutter flexible board from the connector.
  - ③ Remove the vibration-proof flexible board from the connector.
  - ④ Peel the adhesive sheet that secures the vibration-proof flexible board.
- \* When peeling the adhesive sheet, turn it over from the opposite side of the hook.

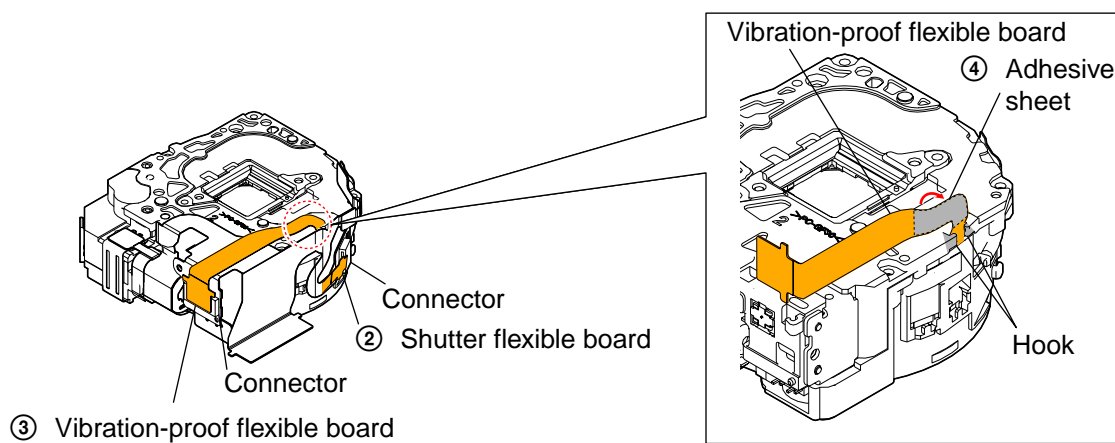

- ⑤ Peel the adhesive sheet (upper) that secures the main flexible board.
  - ⑥ Disengage the main flexible board from the hook of the ring assembly, and then slide the main flexible board to remove.
  - ⑦ Peel the adhesive sheet (lower) that secures the main flexible board.
- \*The FOCUS motor must remain soldered.

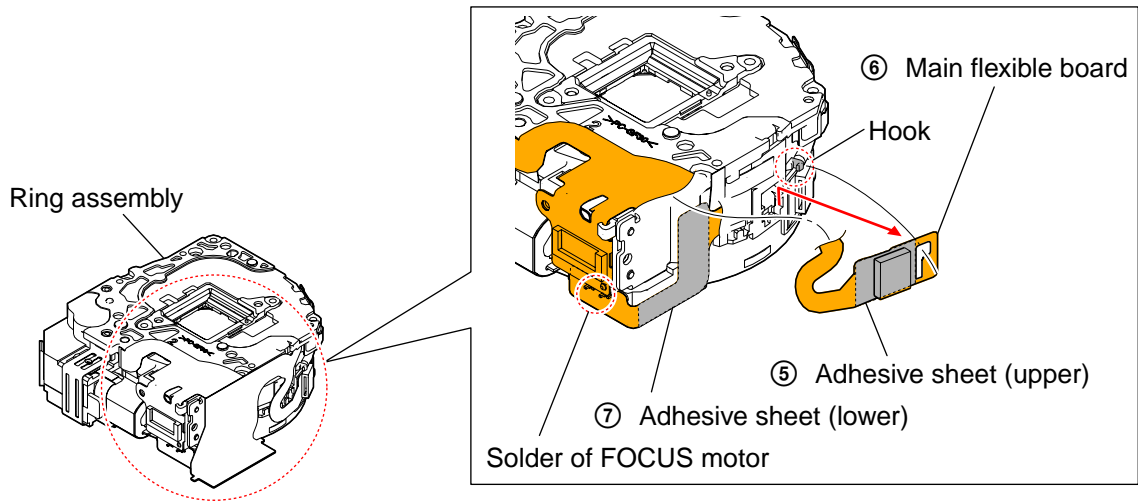

- ⑧ Remove four screws that secure the rear assembly.
  - ⑨ Remove the rear assembly, disengaging the bosses at four places.
- \*Take care not to get stuck with the vibration-proof flexible board.
- ⑩ Unhook the Z leaf spring to remove.
  - ⑪ Remove the main flexible board from the ring assembly, and remove the rear assembly and the nuruto gear.

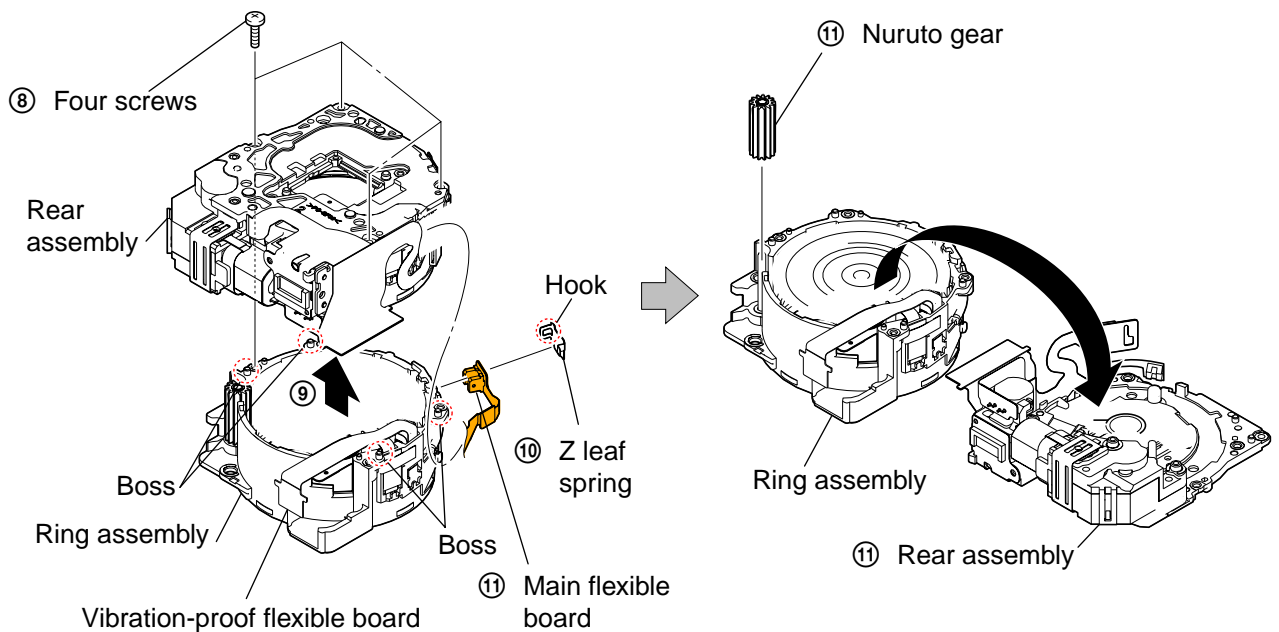

• **HOW TO REMOVE THE ZOOM GEAR BLOCK**

- ① Unsolder the zoom motor.
- ② Remove the FG leaf spring.
- ③ Remove the main flexible board from the zoom gear block.
- ④ Remove the zoom gear block.

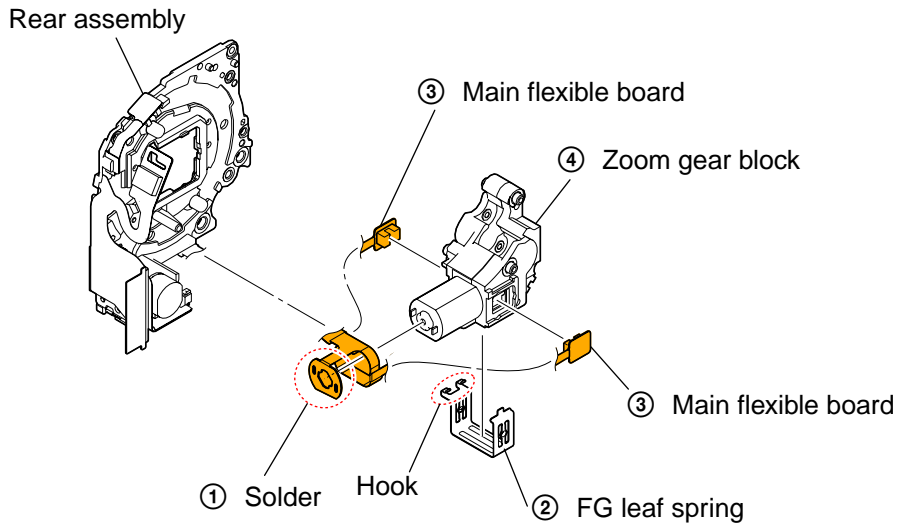

**2-4-2. HOW TO INSTALL THE ZOOM GEAR BLOCK**

• **HOW TO INSTALL THE ZOOM GEAR BLOCK**

- ① Solder the main flexible board to the zoom gear block.
- ② Install the main flexible board to the zoom gear block.
- ③ Attach the FG leaf spring.

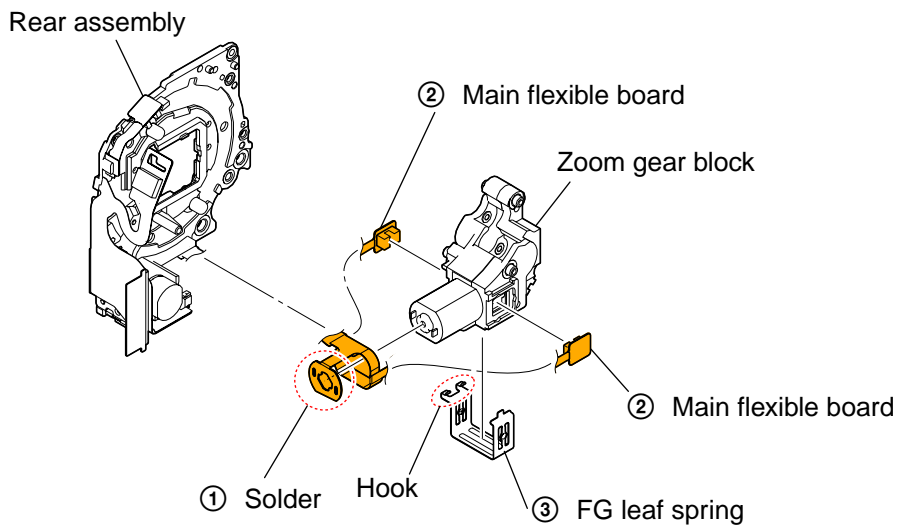

- ④ Apply the lubricant (SRX-4339) to the nuruto gear, and insert it into the ring assembly.  
 \* Rotate the gear in the ring assembly in the arrow direction until the end of the gear is not engaged with a concave portion of the ring assembly (because a convex portion of the rear assembly enters the convex portion).

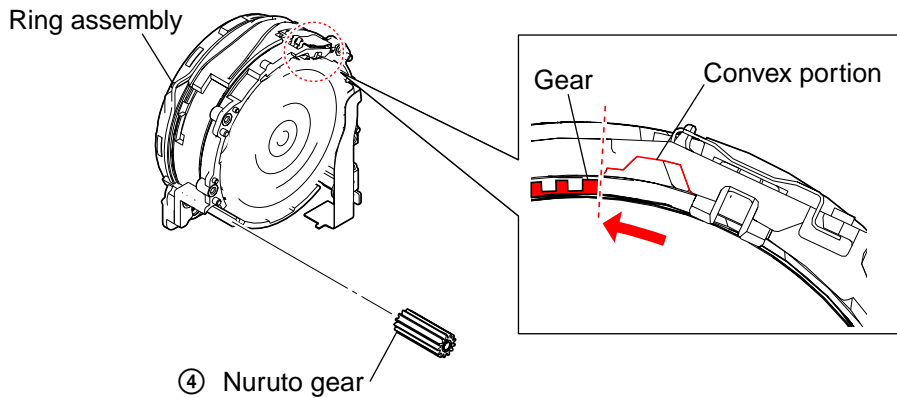

- ⑤ Install the zoom gear block on the rear assembly.  
 ⑥ Engaging four bosses, install the rear assembly on the ring assembly.  
 \* The vibration-proof flexible board must be engaged with the hook of the rear assembly.  
 ⑦ Tighten four screws in the order of (A) to (D).  
 \* Tightening torque =  $0.049 \pm 0.01\text{N} \cdot \text{m}$  ( $0.5 \pm 0.1\text{kgf} \cdot \text{cm}$ )  
 ⑧ Check that the projection of the nuruto shaft that protrudes from the rear assembly is within the specified value given below.  
 \* Specified value: 0.005 – 0.395mm

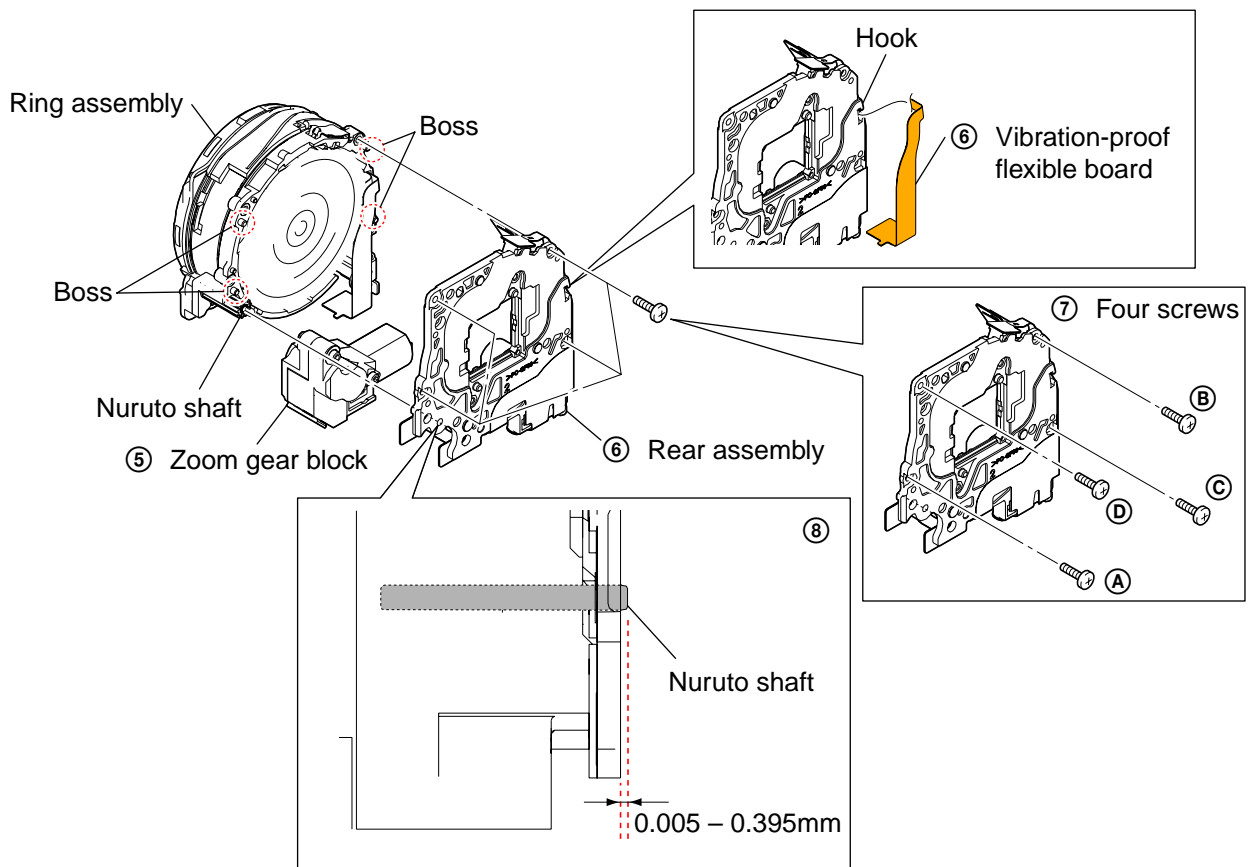

- ⑨ Secure and connect the main flexible board.

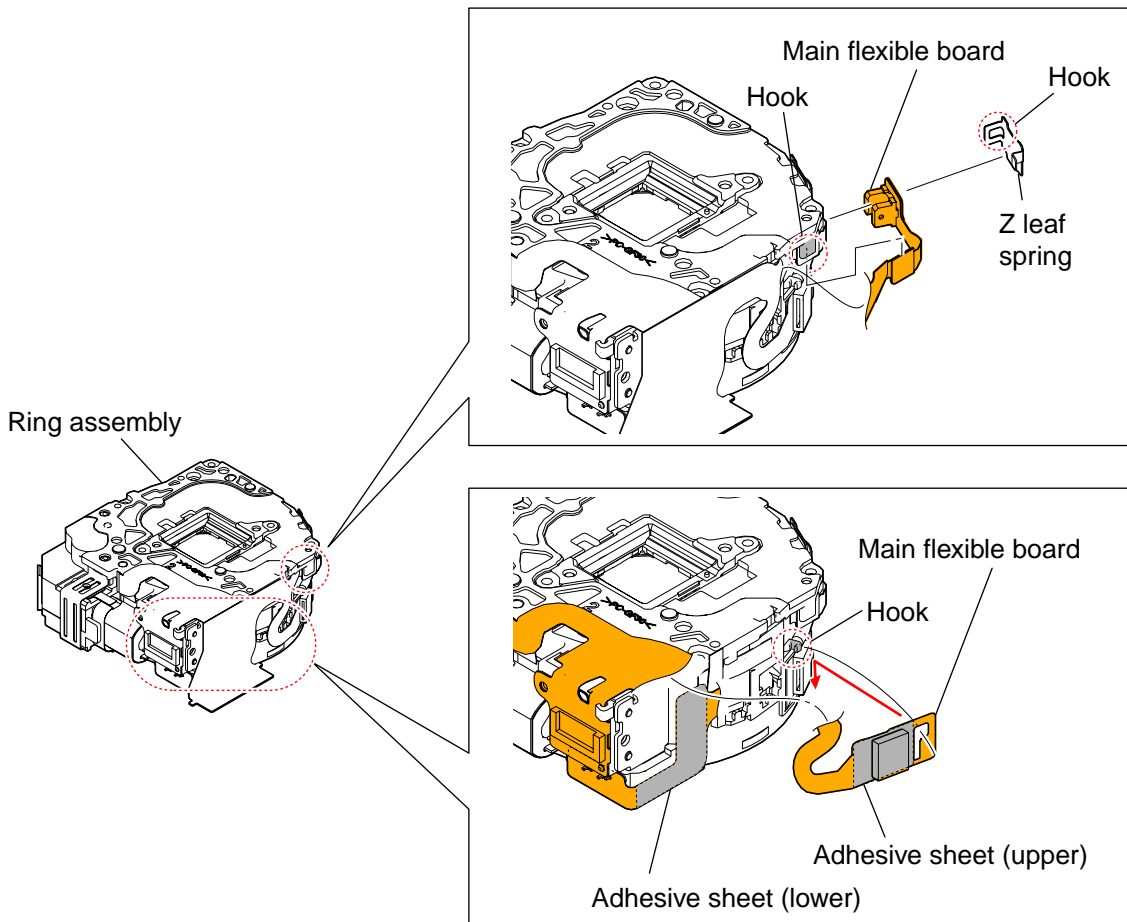

- ⑩ Secure and connect the vibration-proof flexible board and the shutter flexible board respectively.

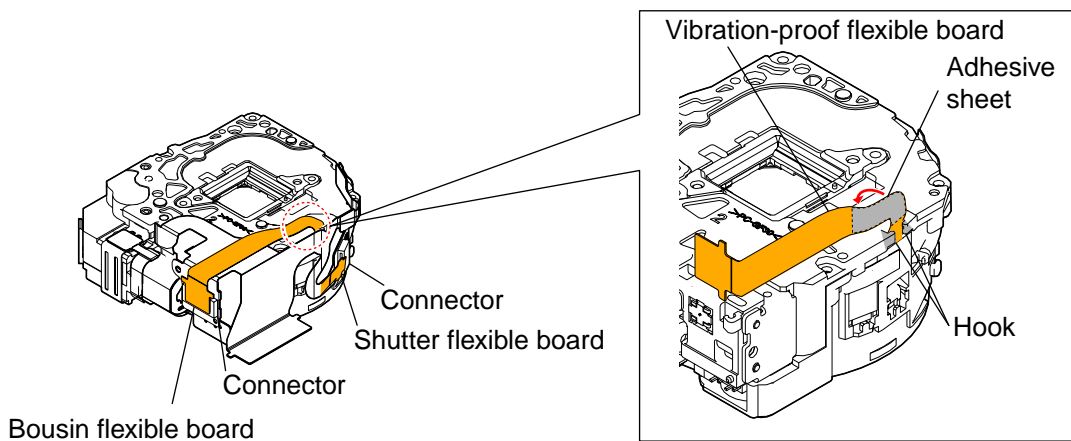

⑪ Install the OVF.

\*When installing the OVF, fit a projection of OVF in the groove of the ring assembly.

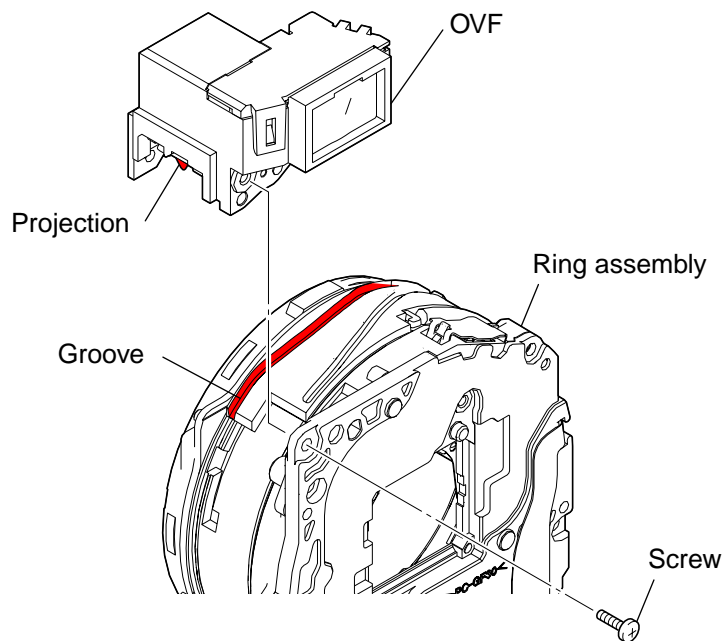

### 2-4-3. CHECK THE OPERATION

Confirm the operation after installing the lens block in the set.

- ① Power ON/OFF
- ② Expansion and contraction confirming of lens and opening and shutting confirmation of barrier.  
Confirm there are neither dirt nor wounds in the surface of the ornamental ring (A) and lens if there is no problem in operation.  
Wipe off when dirty.
- ③ Confirm the operation with Wide/Tele.

**Note:** Do not be of caught etc.

Do not allophone.

# HELP

Sheet attachment positions and procedures of processing the flexible boards/harnesses are shown.

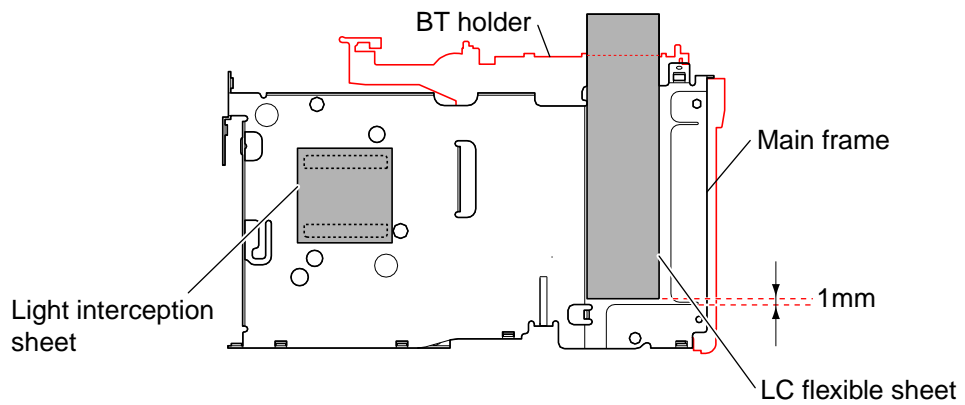
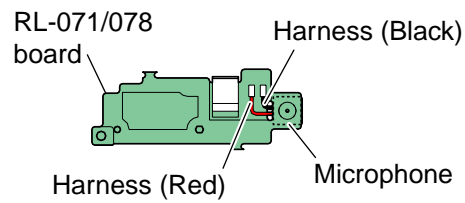
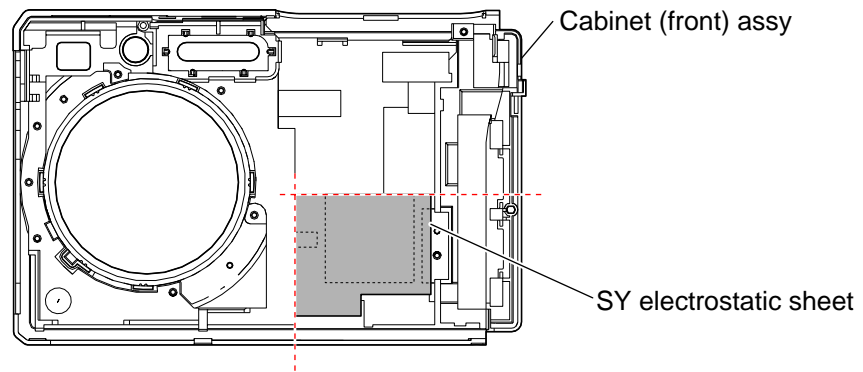

## INSTALLATION METHOD OF BATTERY TERMINAL BOARD

- ① Insert the battery terminal board into a slit in the BT holder to install.  
\*The battery terminal board is attached with the notch for installation.

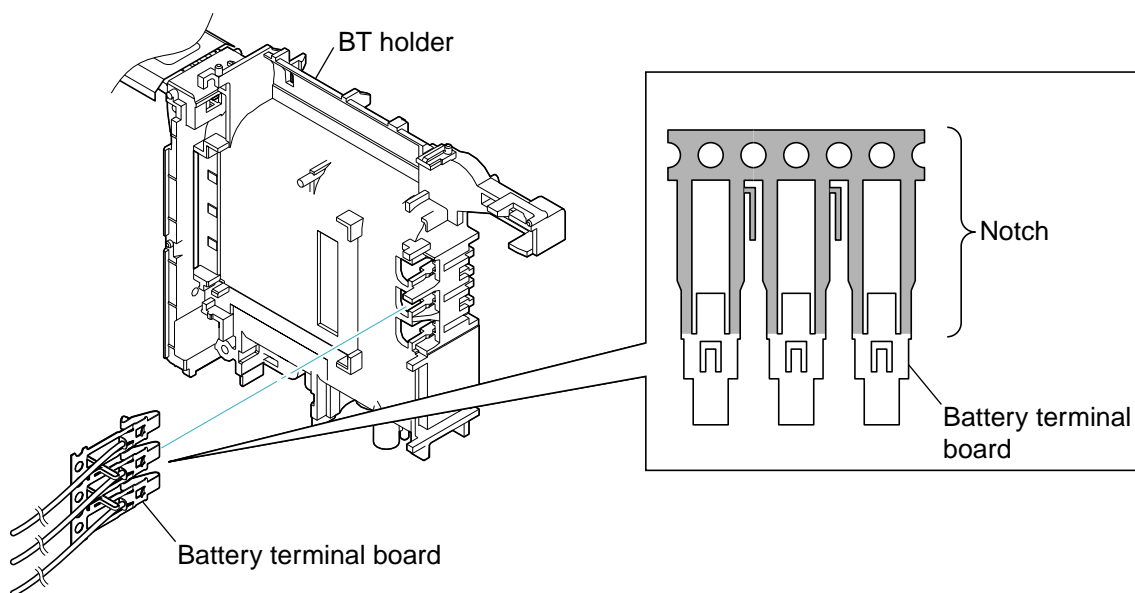

- ② Fold the notch 3 or 4 times repeatedly to break.

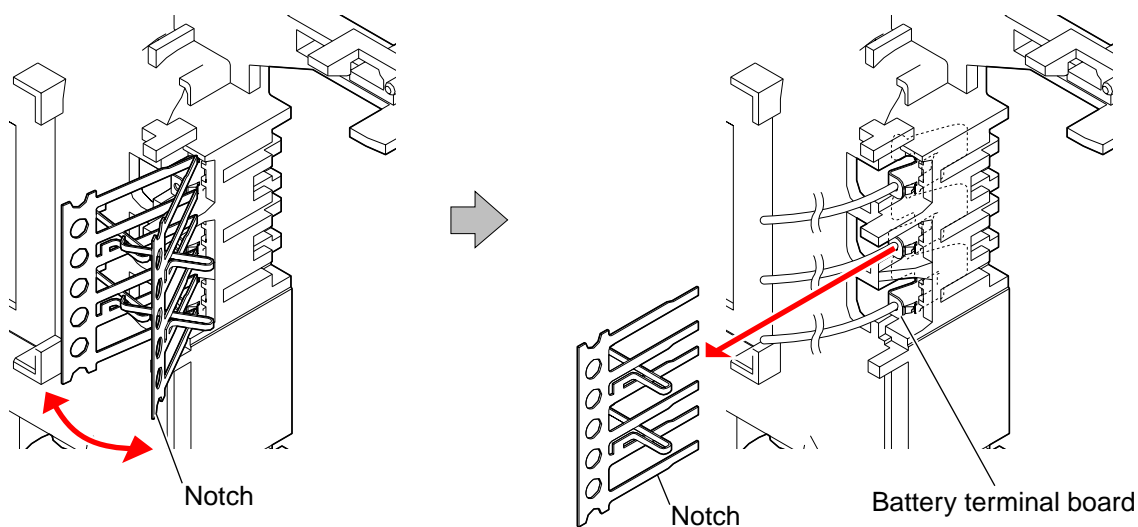

### • HARNESS ARRANGEMENT

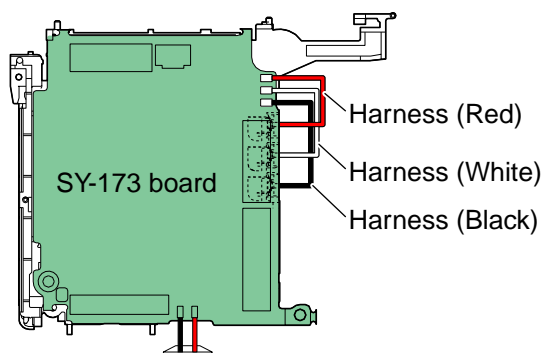

# 3. BLOCK DIAGRAMS

Link

<a href="#">OVERALL BLOCK DIAGRAM (1/2)</a>	<a href="#">POWER BLOCK DIAGRAM (1/2)</a>
<a href="#">OVERALL BLOCK DIAGRAM (2/2)</a>	<a href="#">POWER BLOCK DIAGRAM (2/2)</a>

### 3. BLOCK DIAGRAMS

3-1. OVERALL BLOCK DIAGRAM (1/2) ( ) : Number in parenthesis ( ) indicates the division number of schematic diagram where the component is located.

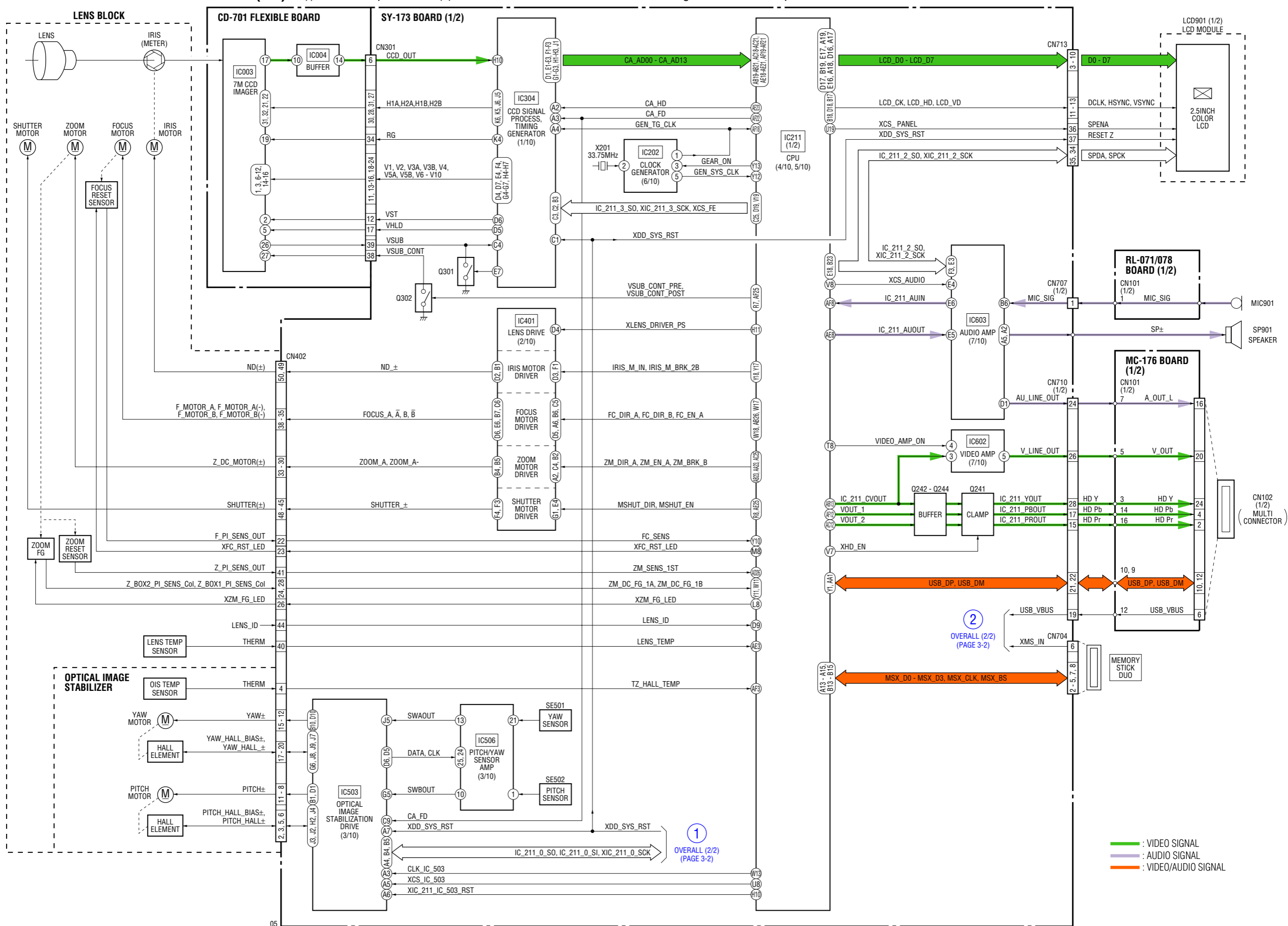

3-2. OVERALL BLOCK DIAGRAM (2/2) ( ) : Number in parenthesis ( ) indicates the division number of schematic diagram where the component is located.

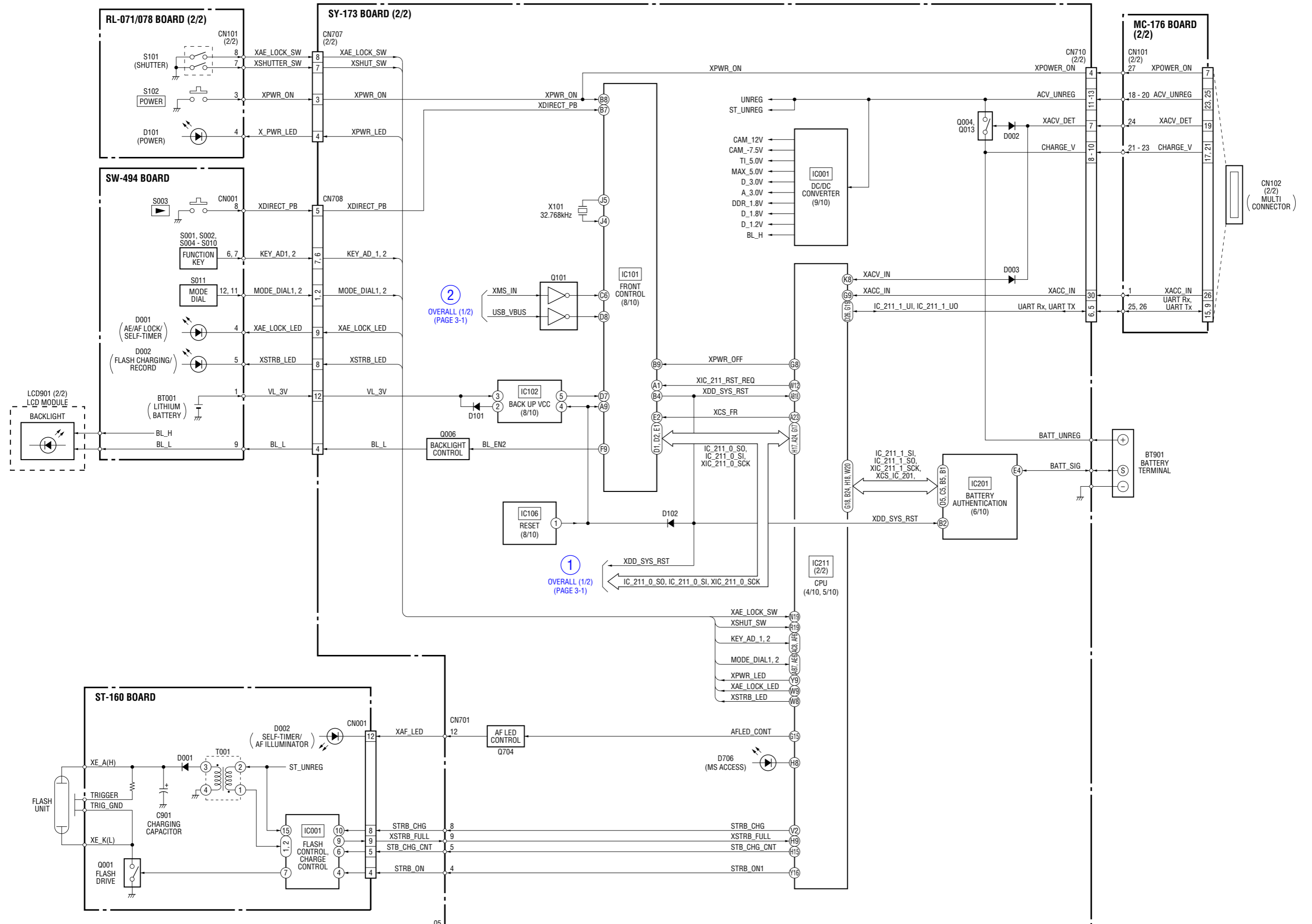

### 3-3. POWER BLOCK DIAGRAM (1/2)

( ) : Number in parenthesis ( ) indicates the division number of schematic diagram where the component is located.

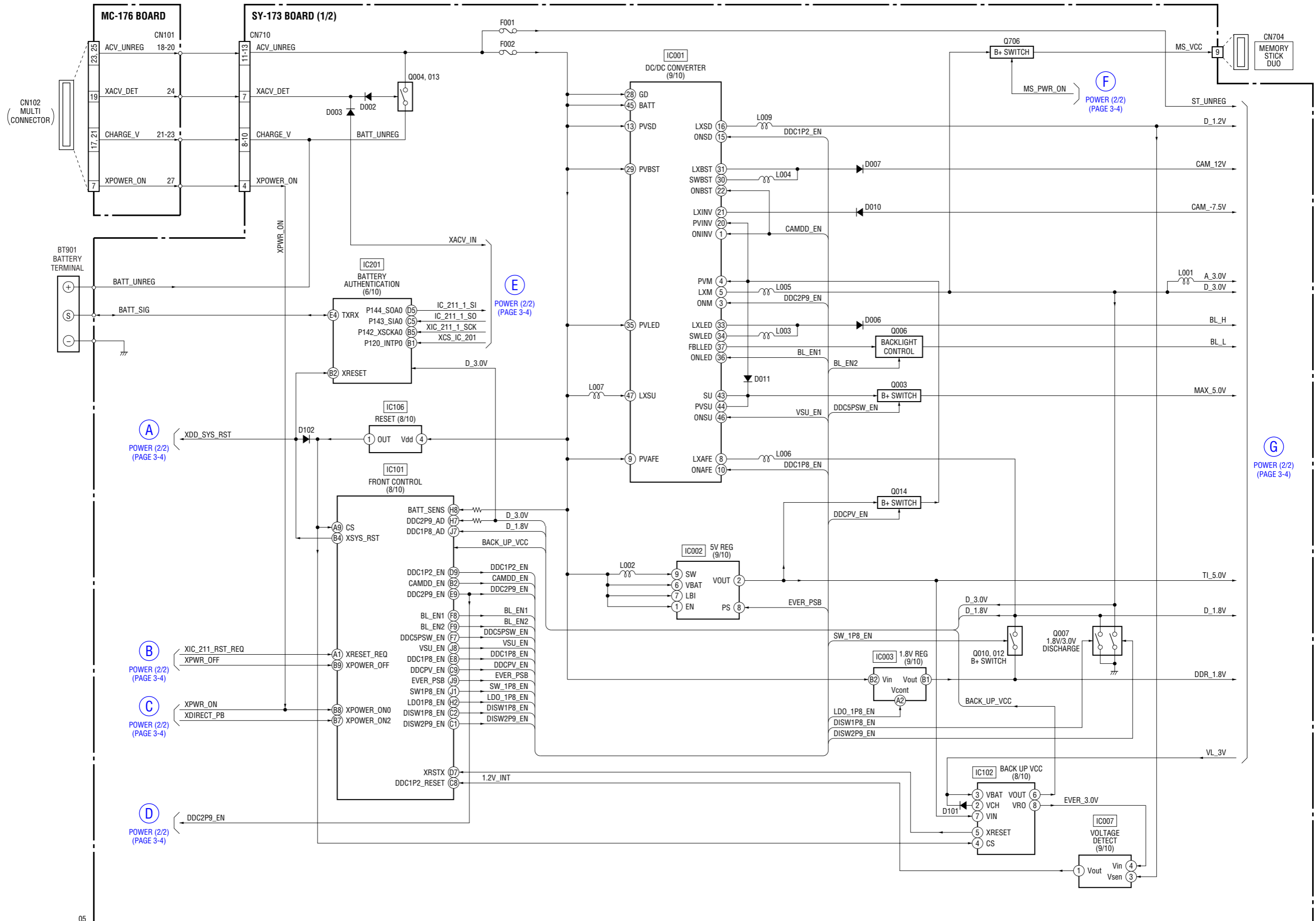

05

3-4. POWER BLOCK DIAGRAM (2/2)

( ) : Number in parenthesis ( ) indicates the division number of schematic diagram where the component is located.

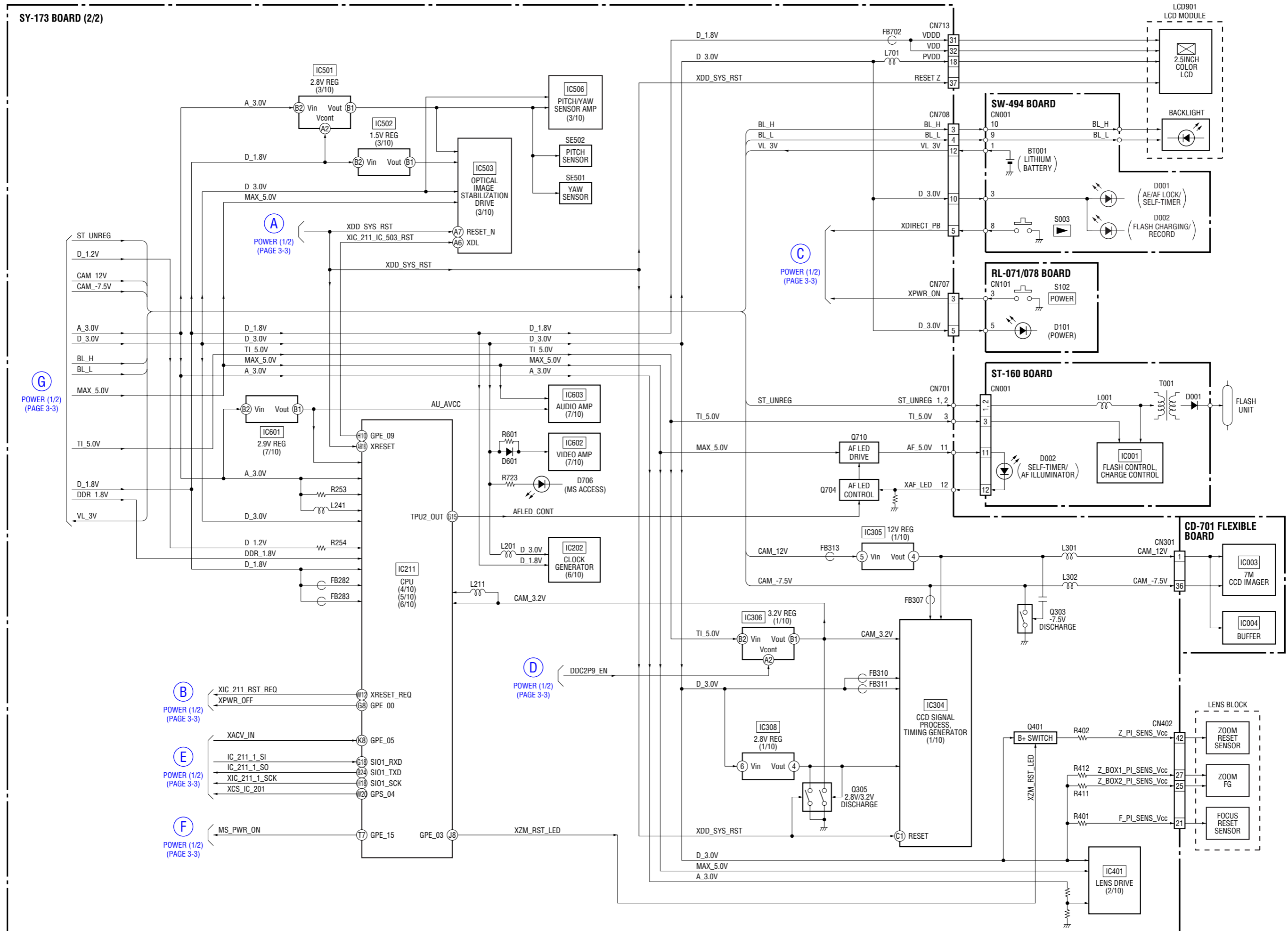

05

# 4. PRINTED WIRING BOARDS AND SCHEMATIC DIAGRAMS

## 4-1. FRAME SCHEMATIC DIAGRAM

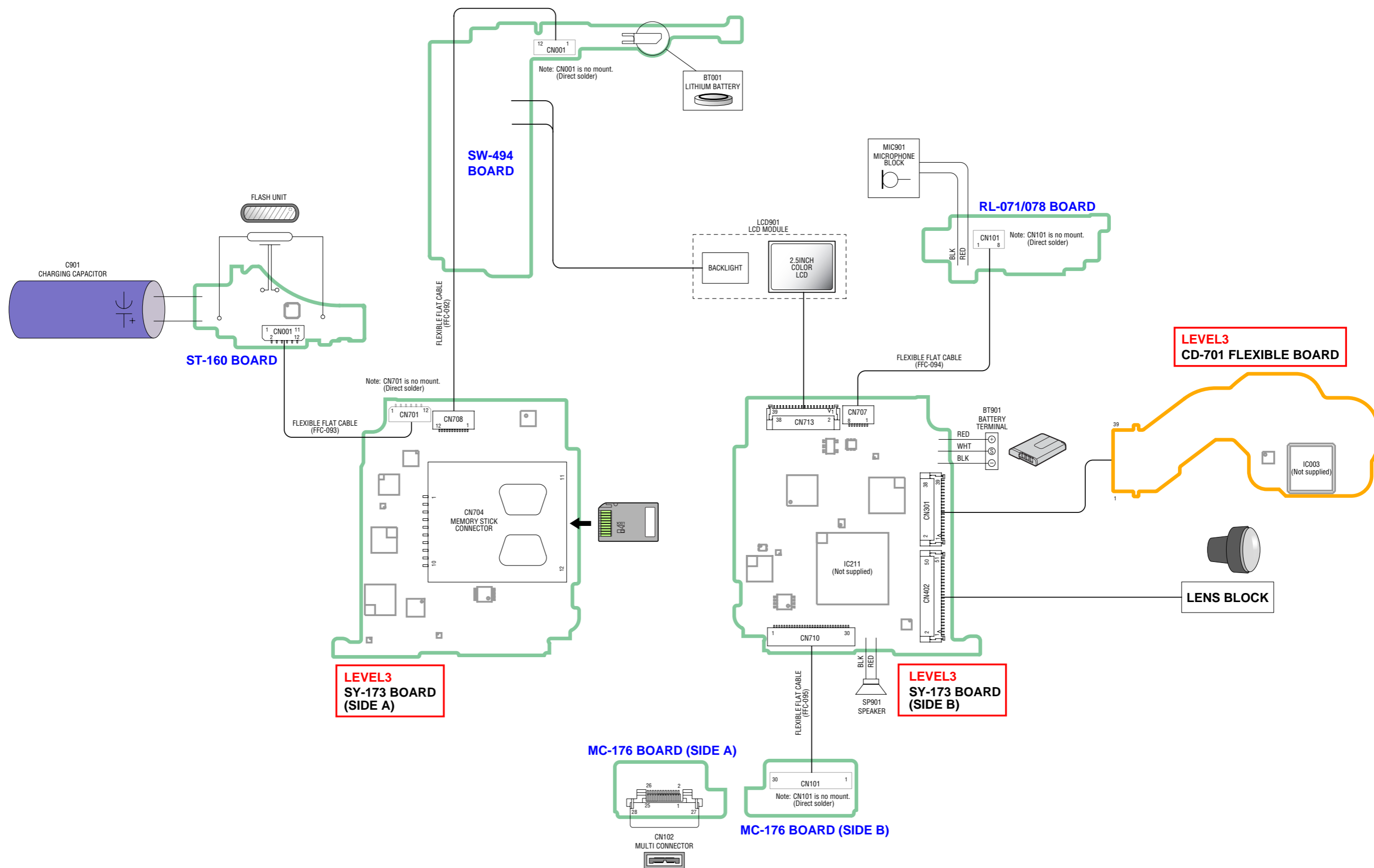

## 4-2. SCHEMATIC DIAGRAMS

### Link

• MC-176 BOARD (MULTI CONNECTOR)

• ST-160 BOARD (FLASH DRIVE)

• SW-494 BOARD (CONTROL SWITCH)

• RL-071/078 BOARD  
(CONTROL SWITCH, MIC)

• COMMON NOTE FOR SCHEMATIC DIAGRAMS

# 4-2. SCHEMATIC DIAGRAMS

## 4-2. SCHEMATIC DIAGRAMS

**THIS NOTE IS COMMON FOR SCHEMATIC DIAGRAMS**  
**(In addition to this, the necessary note is printed in each block)**

**(For schematic diagrams)**

- All capacitors are in  $\mu\text{F}$  unless otherwise noted.  $\text{pF} : \mu\text{F} : 50\text{ V}$  or less are not indicated except for electrolytics and tantalums.
- Chip resistors are  $1/10\text{ W}$  unless otherwise noted.  $\text{k}\Omega=1000\ \Omega$ ,  $\text{M}\Omega=1000\ \text{k}\Omega$ .
- Caution when replacing chip parts. New parts must be attached after removal of chip. Be careful not to heat the minus side of tantalum capacitor, Because it is damaged by the heat.
- Some chip part will be indicated as follows.

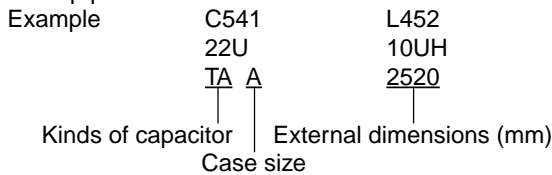

- Constants of resistors, capacitors, ICs and etc with XX indicate that they are not used. In such cases, the unused circuits may be indicated.
- Parts with  $\star$  differ according to the model/destination. Refer to the mount table for each function.
- All variable and adjustable resistors have characteristic curve B, unless otherwise noted.
- Signal name  
 $\text{XEDIT} \rightarrow \text{EDIT}$        $\text{PB/XREC} \rightarrow \text{PB/REC}$
- : non flammable resistor
- : fusible resistor
- : panel designation
- : B+ Line
- : B- Line
- : IN/OUT direction of (+,-) B LINE.
- : adjustment for repair.
- : not use circuit

**(Measuring conditions voltage and waveform)**

- Voltages and waveforms are measured between the measurement points and ground when camera shoots color bar chart of pattern box. They are reference values and reference waveforms. (VOM of DC  $10\text{ M}\Omega$  input impedance is used)
- Voltage values change depending upon input impedance of VOM used.)

**Precautions for Replacement of Imager**

- If the imager has been replaced, carry out all the adjustments for the camera section.
- As the imager may be damaged by static electricity from its structure, handle it carefully like for the MOS IC. In addition, ensure that the receiver is not covered with dusts nor exposed to strong light.

**1. Connection**

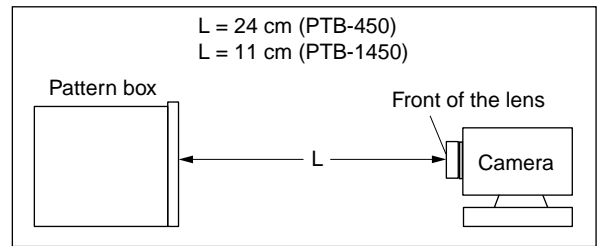
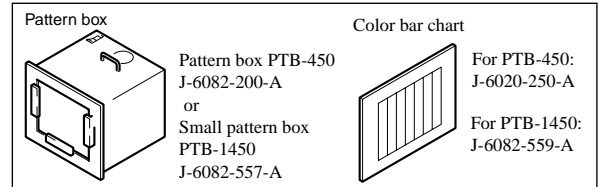

**2. Adjust the distance so that the output waveform of Fig. a and the Fig. b can be obtain.**

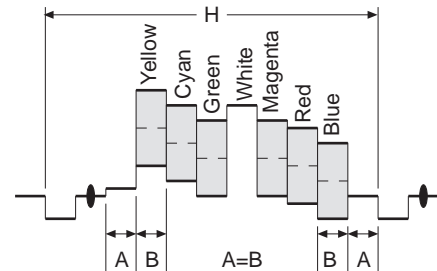

Fig. a (Video output terminal output waveform)

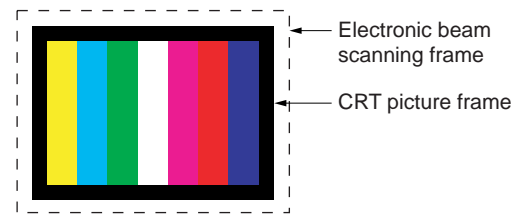

Fig.b (Picture on monitor TV)

When indicating parts by reference number, please include the board name.

The components identified by mark  $\triangle$  or dotted line with mark  $\triangle$  are critical for safety. Replace only with part number specified.

Les composants identifiés par une marque  $\triangle$  sont critiques pour la sécurité. Ne les remplacer que par une pièce portant le numéro spécifié.

Schematic diagrams of the CD-701 flexible and SY-173 boards are not shown.  
Pages from 4-5 to 4-15 are not shown.

1 | 2 | 3 | 4 | 5 | 6 | 7 | 8 | 9 | 10 | 11 | 12

# MC-176 BOARD

## MULTI CONNECTOR

XX MARK:NO MOUNT

Note:CN102 (multi connector) is not supplied,  
but this is included in MC-176 complete board.

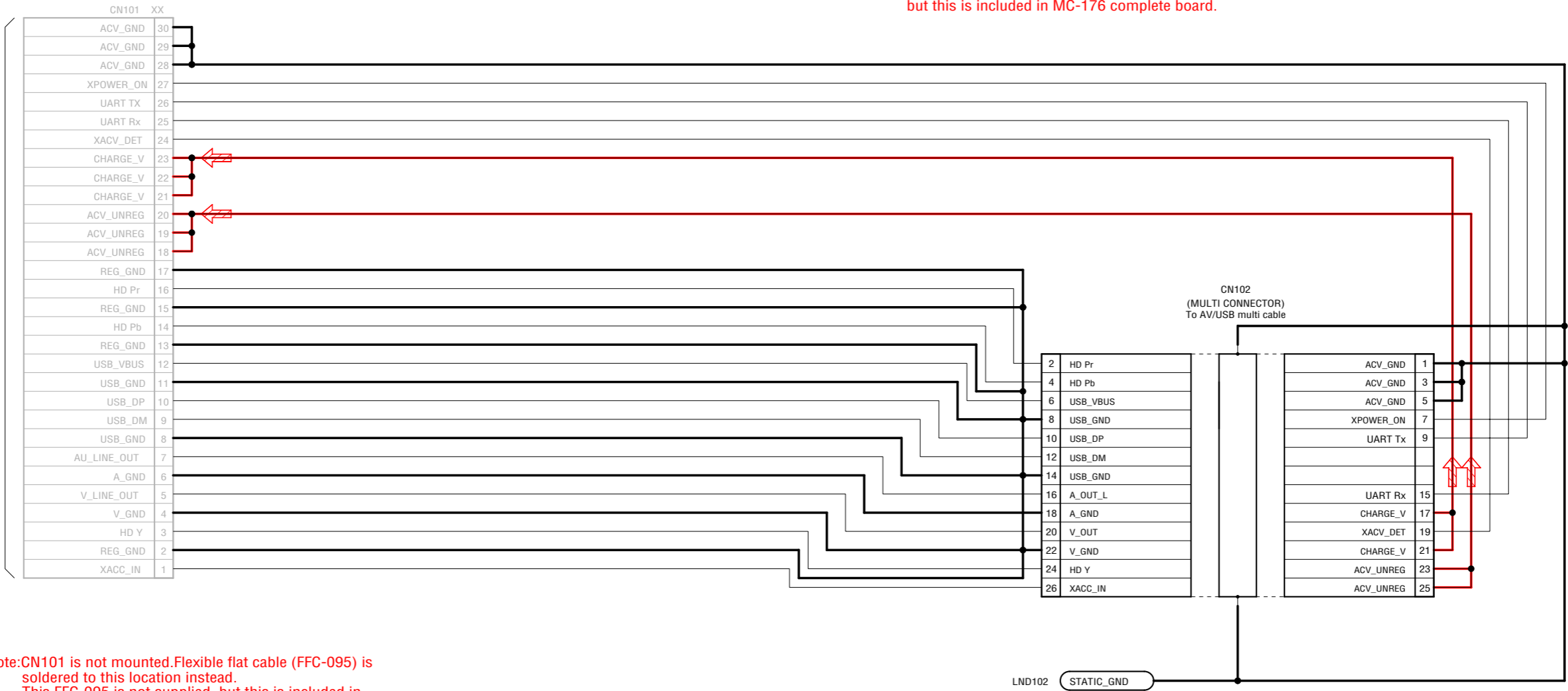

SY-173  
(10/10)  
CN710  
Through the  
flexible flat cable  
(FFC-095)  
(Page 4-15  
of Level 3)

Note:CN101 is not mounted.Flexible flat cable (FFC-095) is  
soldered to this location instead.  
This FFC-095 is not supplied, but this is included in  
MC-176 complete board.

LND102 (STATIC\_GND)

1 | 2 | 3 | 4 | 5 | 6 | 7 | 8 | 9 | 10 | 11 | 12

A

# SW-494 BOARD

## CONTROL SWITCH

XX MARK:NO MOUNT

B

Note:CN001 is not mounted. Flexible flat cable (FFC-092) is soldered to this location instead.

C

SY-173 (10/10) CN708 Through the flexible flat cable (FFC-092) (Page 4-15 of Level 3)

D

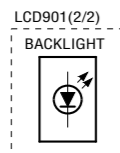

E

F

G

H

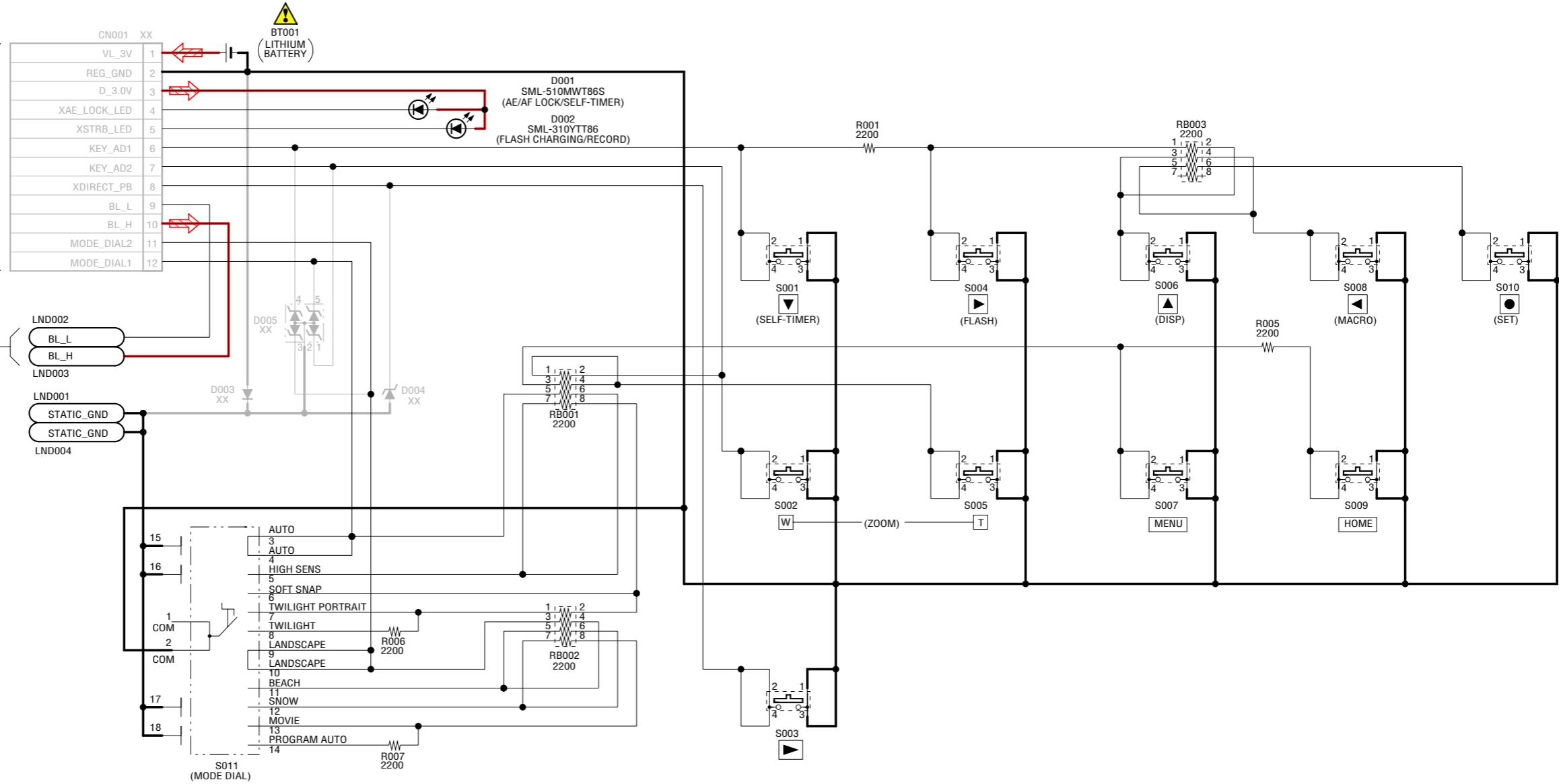

Note:S011(mode dial) is not supplied, but this is included in SW-494 complete board.

# ST-160 BOARD

## FLASH DRIVE

XX MARK:NO MOUNT  
NO MARK:REC/PB MODE

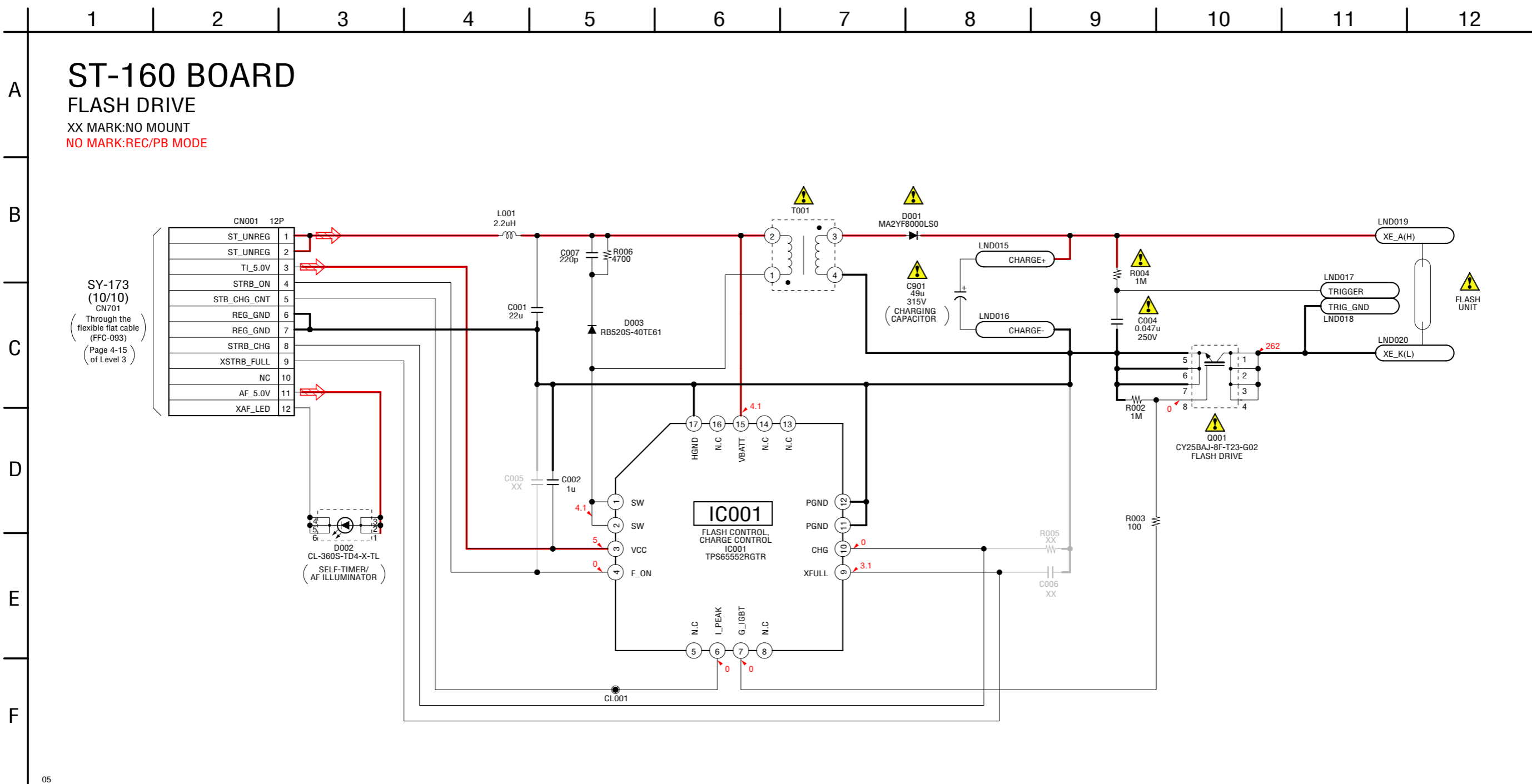

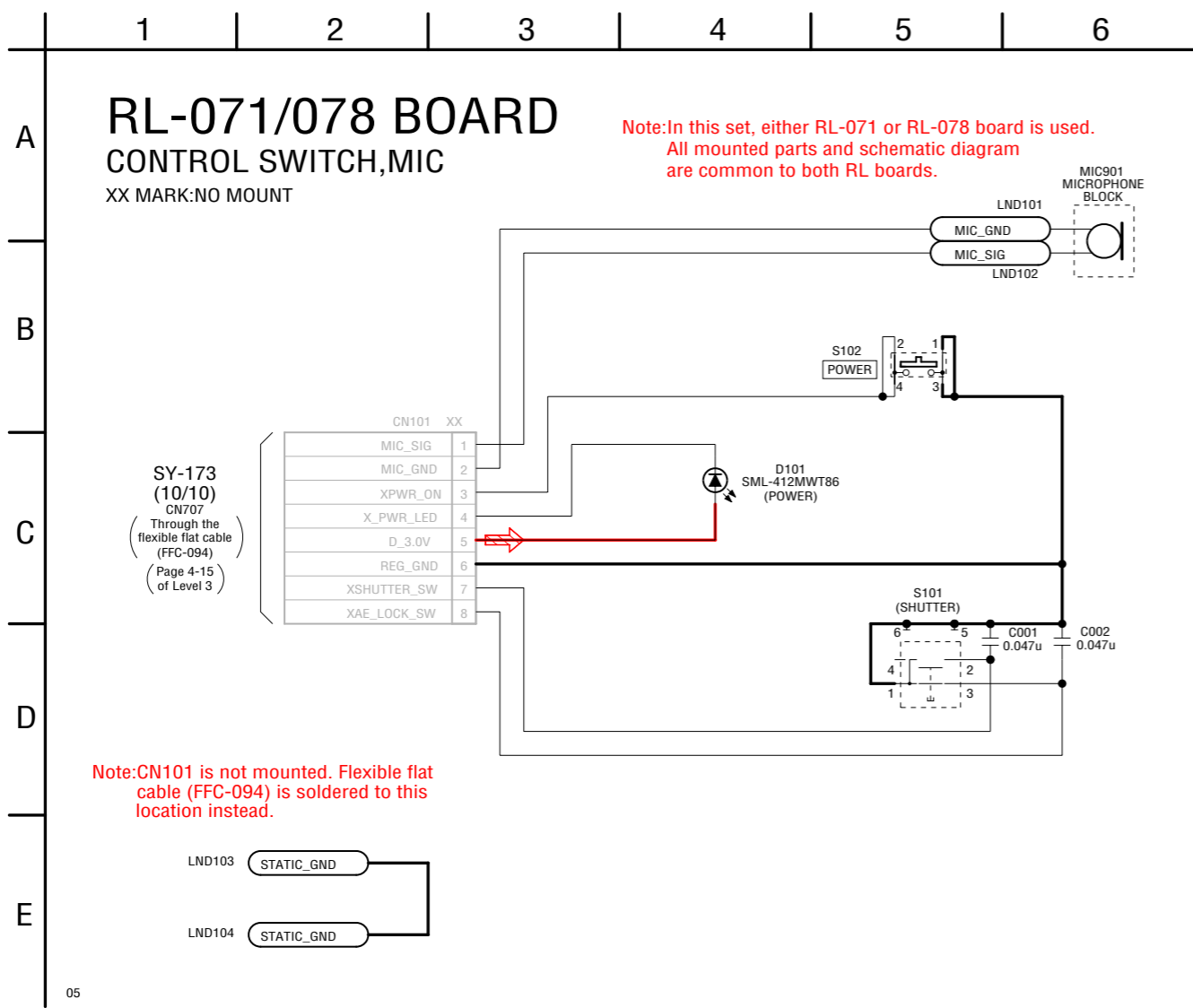

05

## 4-3. PRINTED WIRING BOARDS

### Link

• [MC-176 BOARD](#)

• [ST-160 BOARD](#)

• [SW-494 BOARD](#)

• [RL-071/078 BOARD](#)

• [COMMON NOTE FOR PRINTED WIRING BOARDS](#)

• [MOUNTED PARTS LOCATION](#)

## 4-3. PRINTED WIRING BOARDS

### 4-3. PRINTED WIRING BOARDS

**THIS NOTE IS COMMON FOR PRINTED WIRING BOARDS**

- : Uses unleaded solder.
- : Circuit board
- : Flexible board
- : Pattern from the side which enables seeing.
- : pattern of the rear side  
(The other layers' patterns are not indicated)
- Through hole is omitted.
- Circled numbers refer to waveforms.
- There are a few cases that the part printed on diagram isn't mounted in this model.
- : panel designation

- Chip parts.

Transistor

Diode

Printed wiring boards of the CD-701 flexible and SY-173 boards are not shown.  
Pages from 4-23 to 4-25 are not shown.

**MC-176 (4 layers), SW-494 (2 layers)**

**LF** : Uses unleaded solder.

**MC-176 BOARD (SIDE A)**

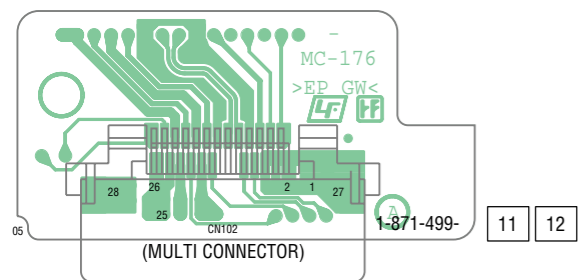

Note: CN102 (multi connector) is not supplied, but this is included in MC-176 complete board.

**MC-176 BOARD (SIDE B)**

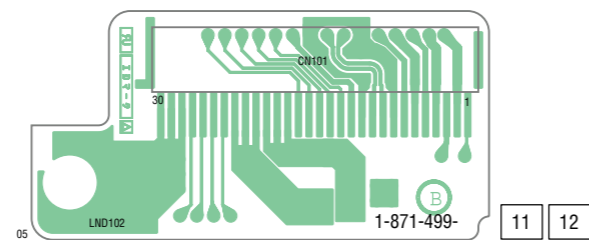

Note: CN101 is not mounted. Flexible flat cable (FFC-095) is soldered to this location instead. This FFC-095 is not supplied, but this is included in MC-176 complete board.

**SW-494 BOARD (SIDE A)**

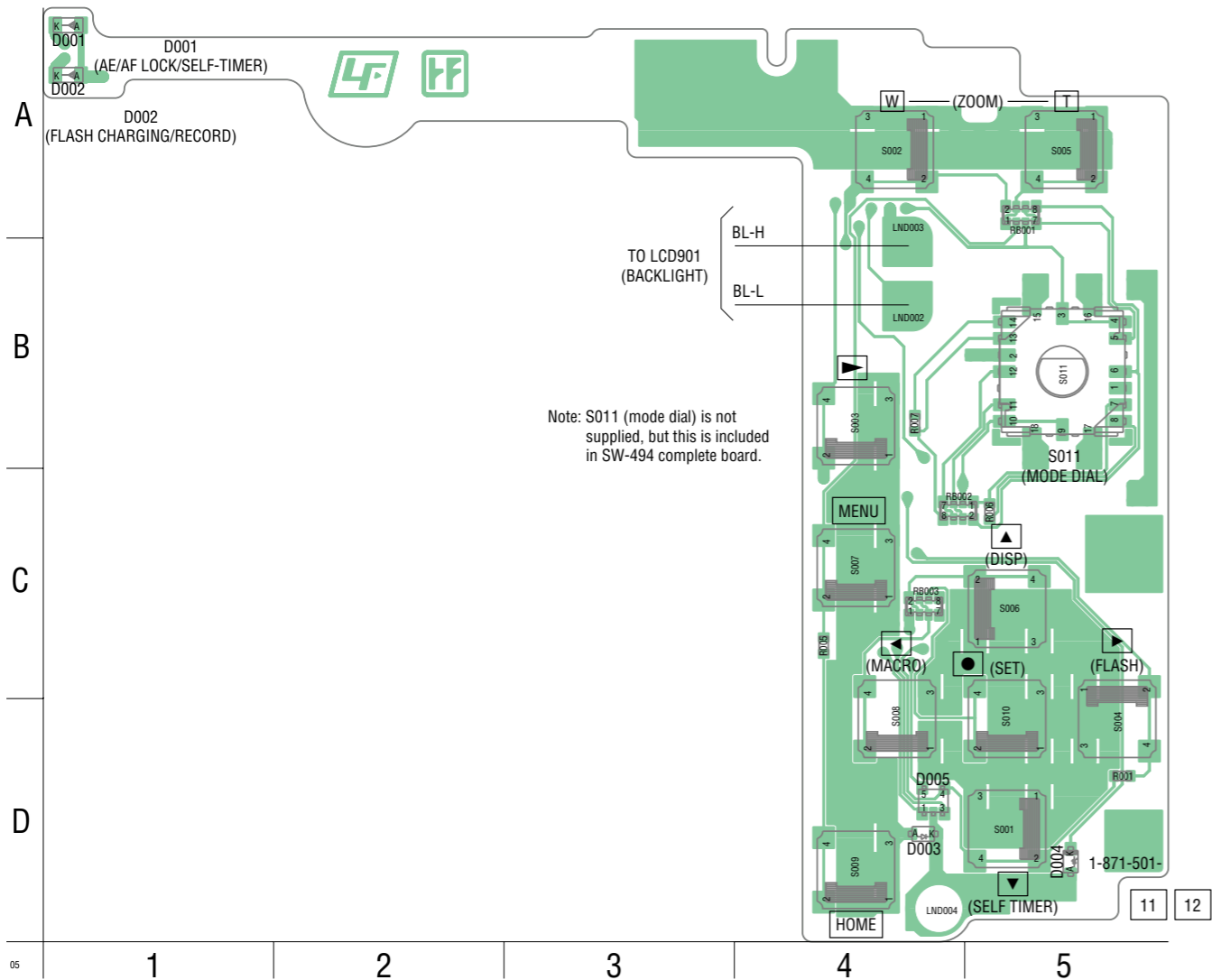

Note: S011 (mode dial) is not supplied, but this is included in SW-494 complete board.

**SW-494 BOARD (SIDE B)**

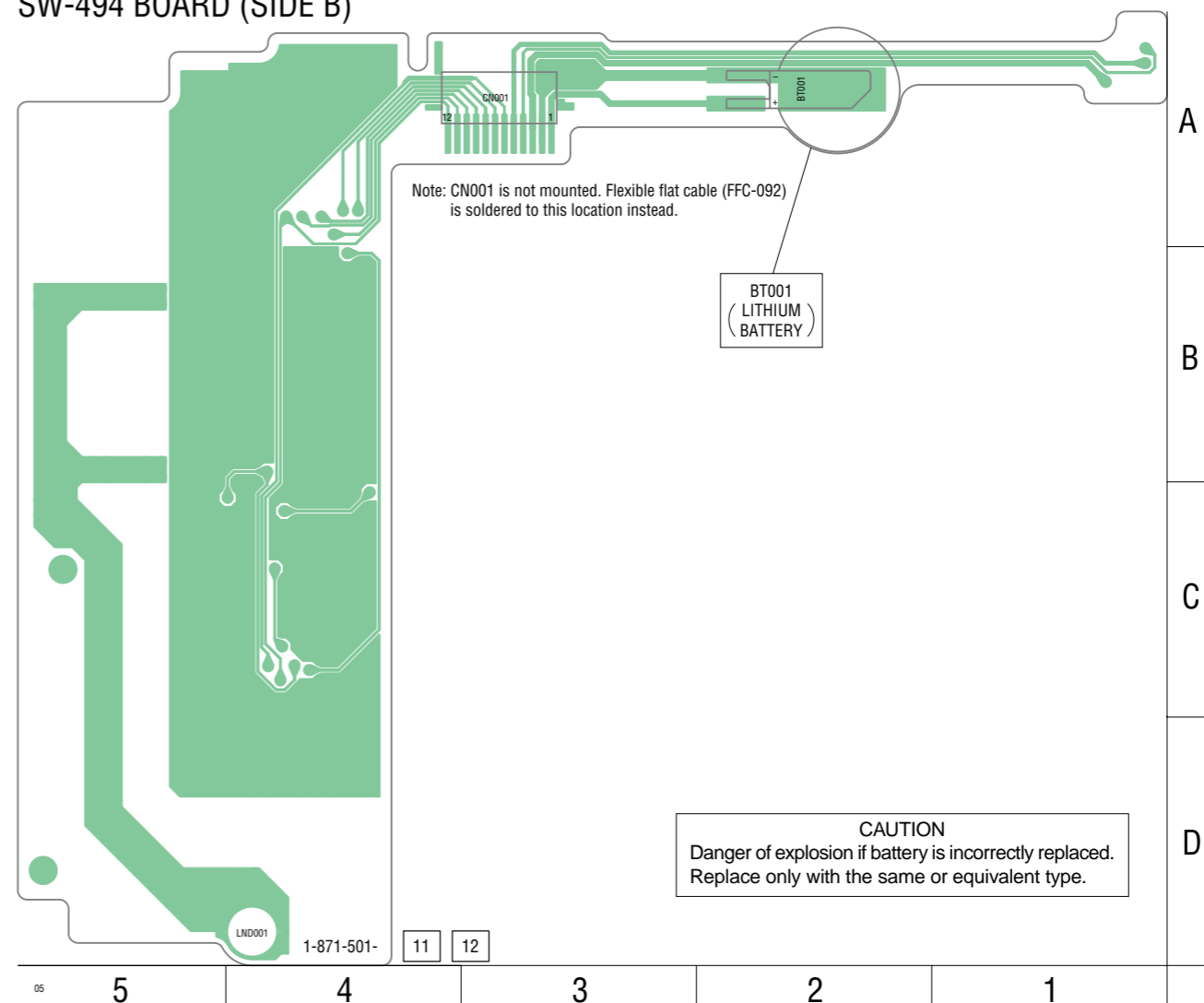

Note: CN001 is not mounted. Flexible flat cable (FFC-092) is soldered to this location instead.

**CAUTION**  
Danger of explosion if battery is incorrectly replaced.  
Replace only with the same or equivalent type.

ST-160 (4 layers), RL-071/078 (2 layers)

 : Uses unleaded solder.

ST-160 BOARD (SIDE A)

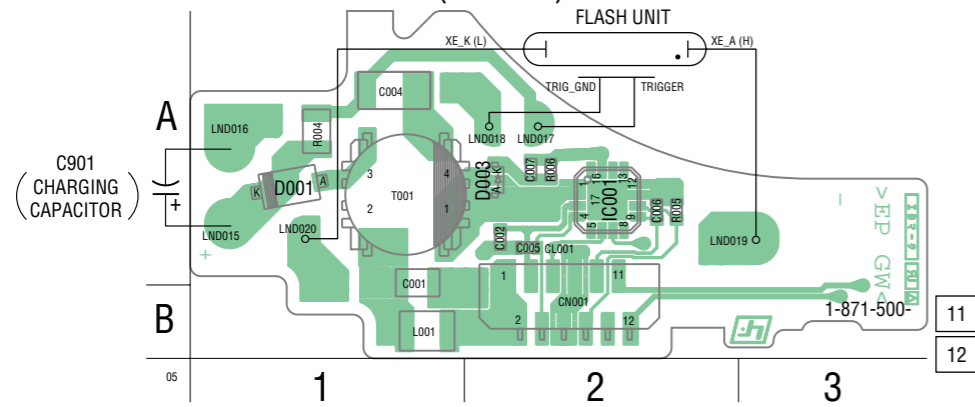

ST-160 BOARD (SIDE B)

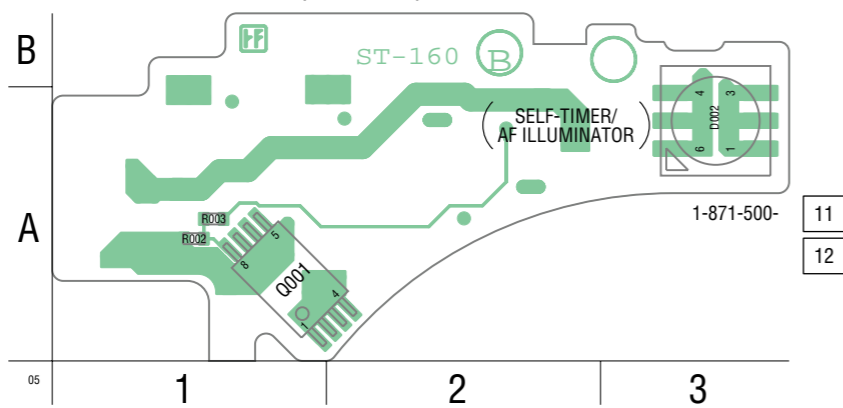

RL-071 BOARD (SIDE A)

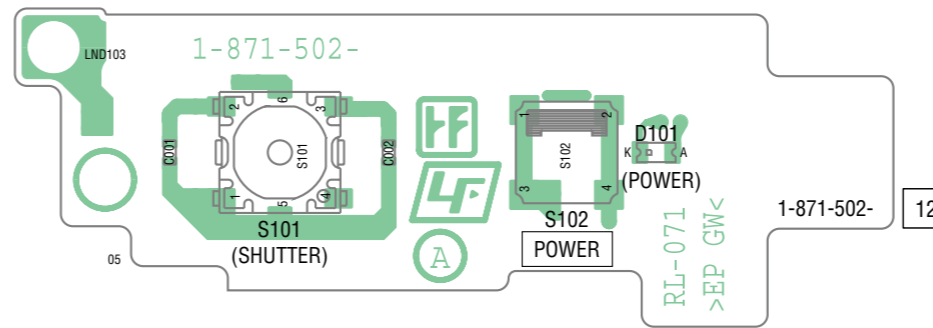

RL-071 BOARD (SIDE B)

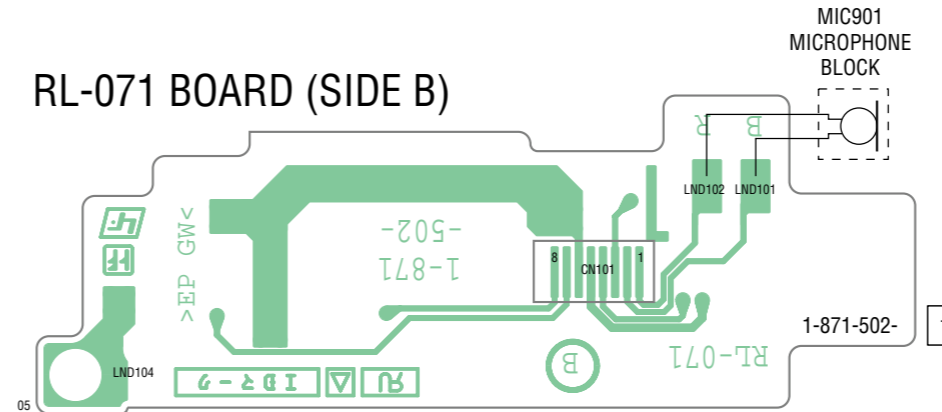

Note: CN101 is not mounted. Flexible flat cable (FFC-094) is soldered to this location instead.

**Note:** In this set, either RL-071 or RL-078 board is used. All mounted parts and schematic diagram are common to both RL boards.

RL-078 BOARD (SIDE A)

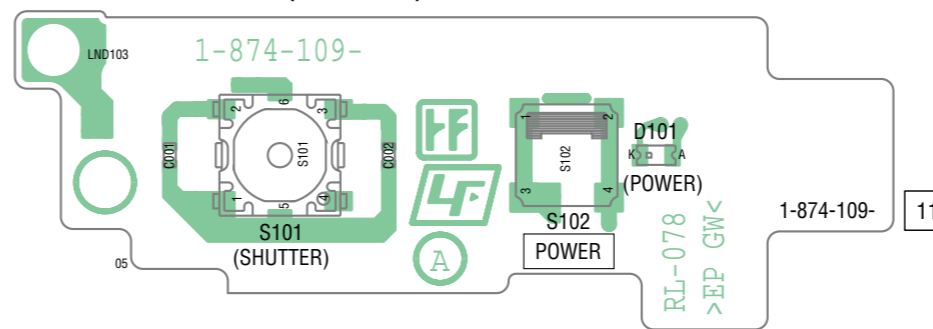

RL-078 BOARD (SIDE B)

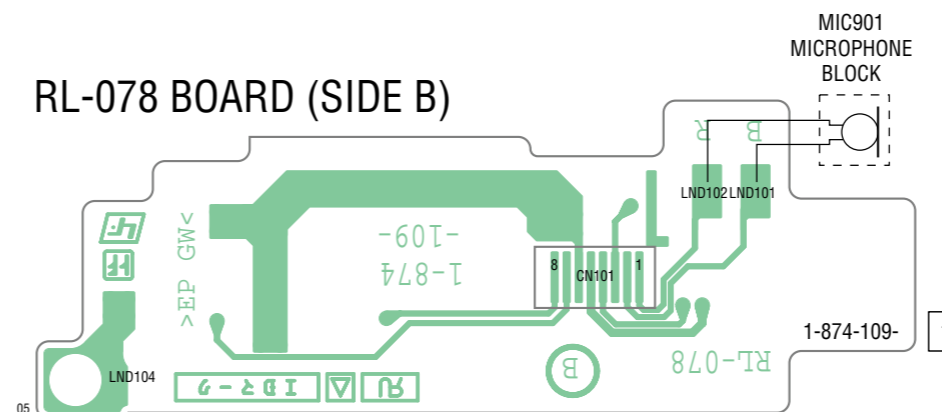

Note: CN101 is not mounted. Flexible flat cable (FFC-094) is soldered to this location instead.

Mounted parts location of the SY-171 board is not shown.  
Pages 4-29 and 4-30 are not shown.

## 4-3. PRINTED WIRING BOARDS

### 4-4. MOUNTED PARTS LOCATION

no mark : side A  
 \* mark : side B

SW-494 BOARD	ST-160 BOARD
* BT001 A-2	C001 A-1
	C002 A-2
* CN001 A-3	C004 A-1
	C007 A-2
D001 A-1	
D002 A-1	CN001 B-2
R001 D-5	D001 A-1
R005 C-4	* D002 A-3
R006 C-5	D003 A-2
R007 B-4	
	IC001 A-2
RB001 A-5	
RB002 C-4	L001 B-1
RB003 C-4	
	* Q001 A-1
S001 D-5	
S002 A-4	* R002 A-1
S003 B-4	* R003 A-1
S004 D-5	R004 A-1
S005 A-5	R006 A-2
S006 C-5	
S007 C-4	T001 A-1
S008 D-4	
S009 D-4	
S010 D-5	
S011 B-5	

# 5. REPAIR PARTS LIST

NOTE: Characters **A** to **Z** of the electrical parts list indicate location of exploded views in which the desired part is shown.

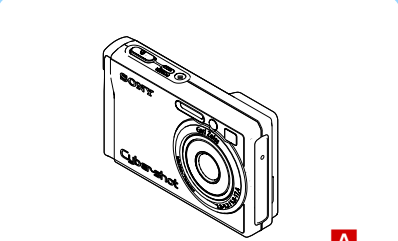
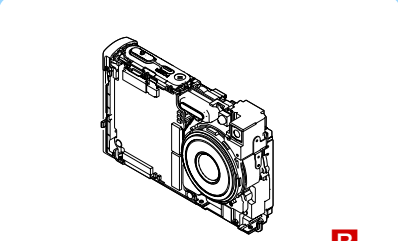
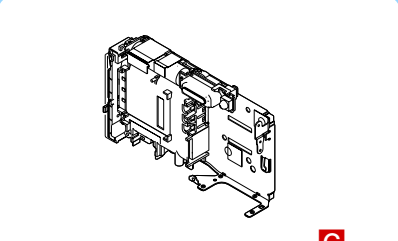
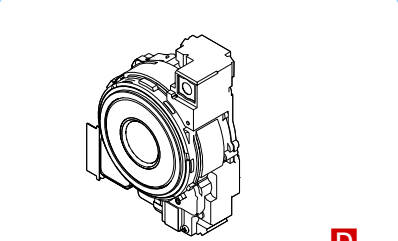
Link	EXPLODED VIEWS		
 <b>A</b>	 <b>B</b>	 <b>C</b>	
<b>CABINET SECTION</b>	<b>MAIN BOARD SECTION</b>	<b>LCD/BT HOLDER SECTION</b>	
 <b>D</b>			
<b>LENS SECTION</b>			

Link	ELECTRICAL PARTS LIST			ACCESSORIES
<ul style="list-style-type: none"><li>MC-176 BOARD <b>B</b></li></ul>	<ul style="list-style-type: none"><li>ST-160 BOARD <b>C</b></li></ul>	<ul style="list-style-type: none"><li>SW-494 BOARD <b>C</b></li></ul>		
<ul style="list-style-type: none"><li>RL-071/078 BOARD <b>B</b></li></ul>				

## 5. REPAIR PARTS LIST

### 5. REPAIR PARTS LIST

**NOTE:**

- -XX, -X mean standardized parts, so they may have some differences from the original one.
- Items marked “\*” are not stocked since they are seldom required for routine service. Some delay should be anticipated when ordering these items.
- The mechanical parts with no reference number in the exploded views are not supplied.
- Due to standardization, replacements in the parts list may be different from the parts specified in the diagrams or the components used on the set.
- CAPACITORS:  
uF:  $\mu$ F
- COILS  
uH:  $\mu$ H
- RESISTORS  
All resistors are in ohms.  
METAL: metal-film resistor  
METAL OXIDE: Metal Oxide-film resistor  
F: nonflammable
- SEMICONDUCTORS  
In each case, u:  $\mu$ , for example:  
uA...:  $\mu$ A... , uPA... ,  $\mu$ PA... ,  
uPB... ,  $\mu$ PB... ,  $\mu$ PC... ,  $\mu$ PC... ,  
uPD... ,  $\mu$ PD...
- Abbreviation  
AR : Argentine model  
AUS : Australian model  
BR : Brazilian model  
CH : Chinese model  
CND : Canadian model  
EE : East European model  
HK : Hong Kong model  
J : Japanese model  
JE : Tourist model  
KR : Korea model  
NE : North European model  
TW : Taiwan model

When indicating parts by reference number, please include the board name.

The components identified by mark  $\Delta$  or dotted line with mark  $\Delta$  are critical for safety. Replace only with part number specified.

Les composants identifiés par une marque  $\Delta$  sont critiques pour la sécurité. Ne les remplacer que par une pièce portant le numéro spécifié.

- Color Indication of Appearance Parts  
Example:  
(SILVER) : Cabinet's Color  
(Silver) : Parts Color

# 5. REPAIR PARTS LIST

## DISASSEMBLY

## HARDWARE LIST

### 5-1. EXPLODED VIEWS

#### 5-1-1. CABINET SECTION

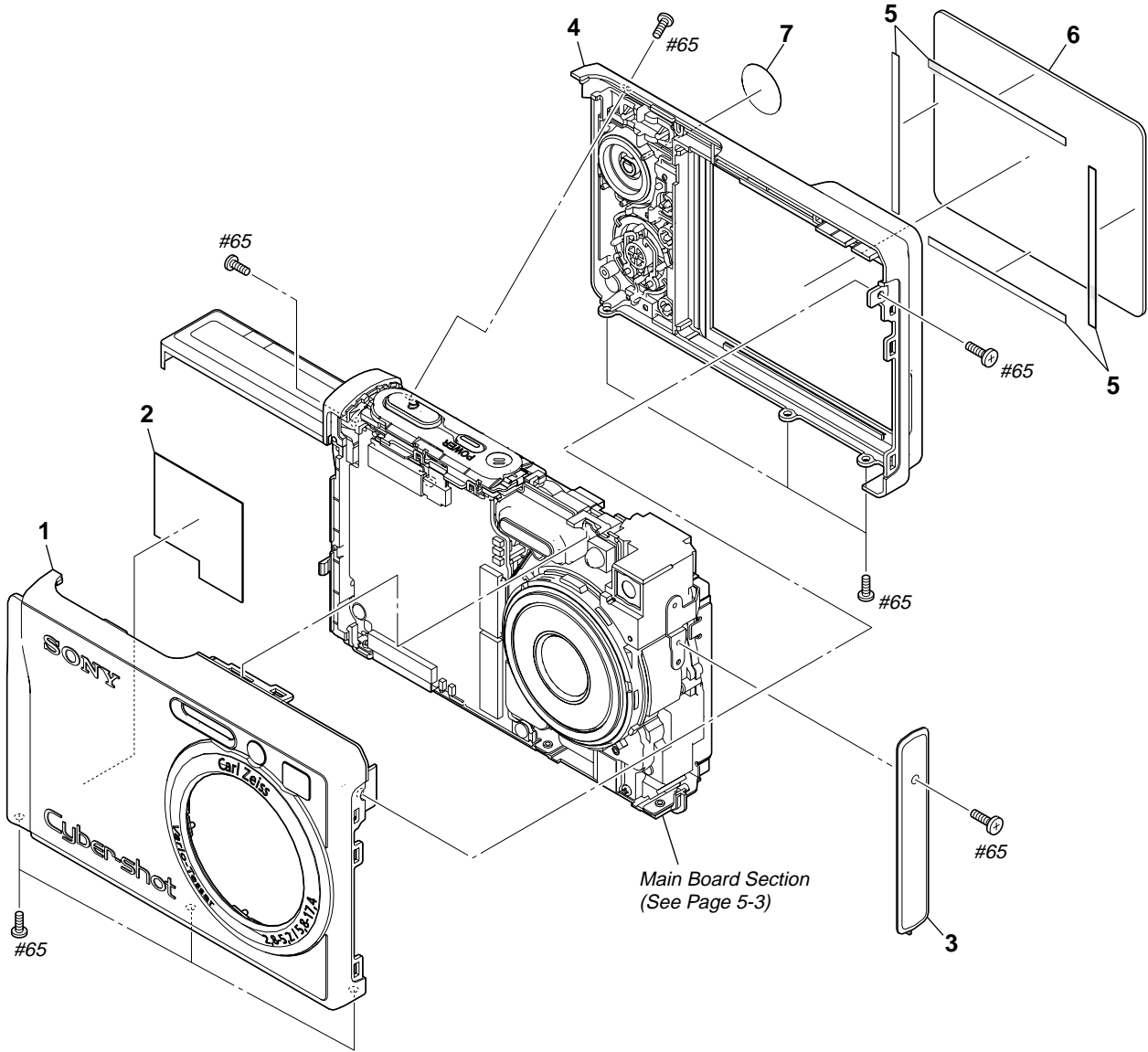

Ref. No.	Part No.	Description
1	X-2177-050-1	CABINET (FRONT) ASSY (W80: SILVER)
1	X-2177-051-1	CABINET (FRONT) ASSY (W80: BLACK/W85)
1	X-2177-052-1	CABINET (FRONT) ASSY (W80: WHITE)
1	X-2177-053-1	CABINET (FRONT) ASSY (W80: PINK)
* 2	3-197-910-01	SHEET, SY ELECTROSTATIC
3	3-099-623-01	CABINET, SIDE
4	X-2177-061-1	CABINET (REAR) ASSY (W80: SILVER)
4	X-2177-062-1	CABINET (REAR) ASSY (W80: BLACK)

Ref. No.	Part No.	Description
4	X-2177-063-1	CABINET (REAR) ASSY (W80: WHITE)
4	X-2177-064-1	CABINET (REAR) ASSY (W80: PINK)
4	X-2177-065-1	CABINET (REAR) ASSY (W85)
5	3-099-626-01	SHEET, LCD WINDOW ADHESIVE
6	3-099-624-01	WINDOW, LCD
7	3-099-625-01	PLATE, MODE
#65	2-635-591-01	SCREW (M1.4), NEW TRUSTAR P2 (Silver)

# 5. REPAIR PARTS LIST

## DISASSEMBLY

## HARDWARE LIST

### 5-1-2. MAIN BOARD SECTION

ns: not supplied

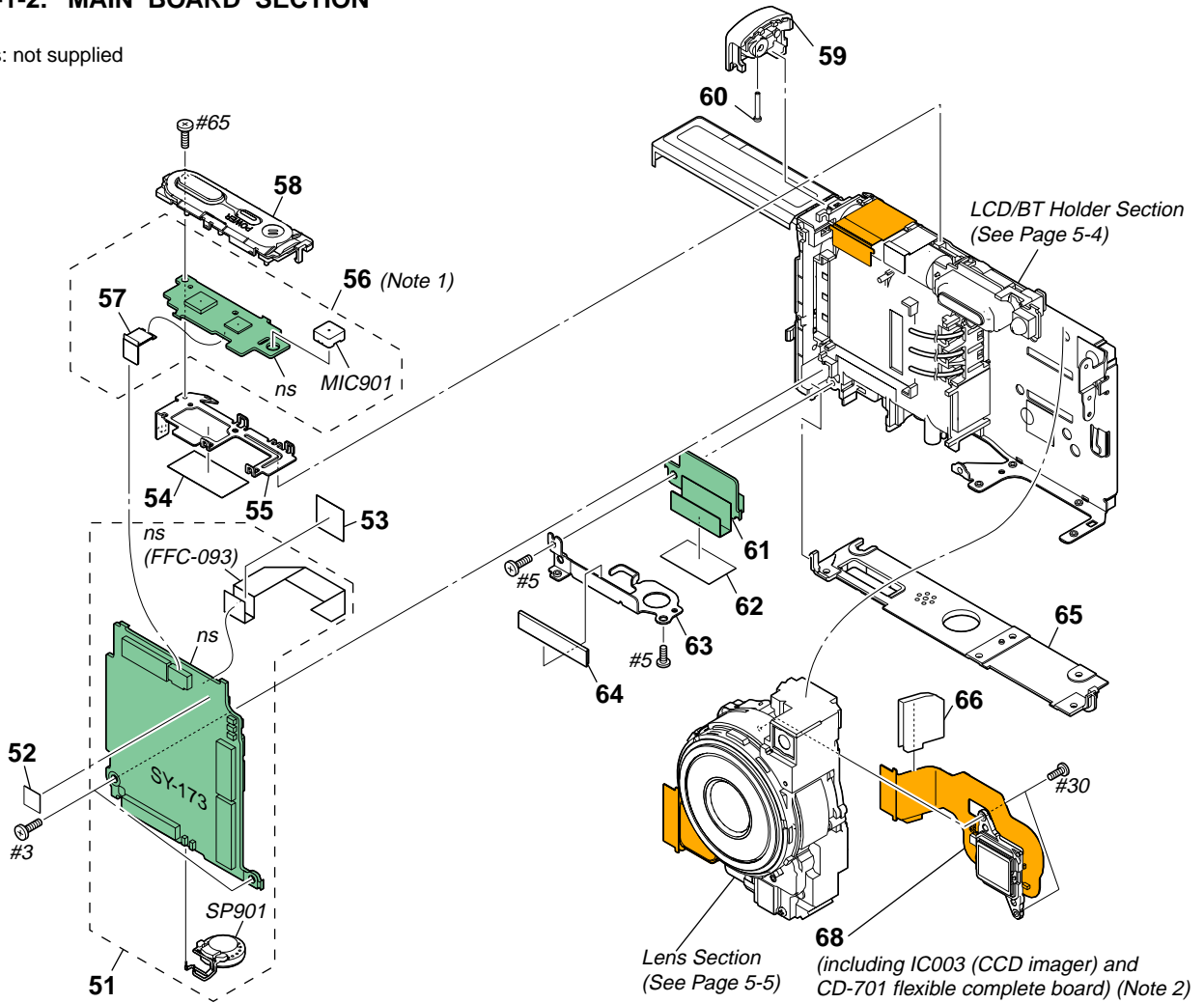

**Note 1:** In this set, either RL-071 or RL-078 board is used. All mounted parts and schematic diagram are common to both RL boards.

**Note 2:** Be sure to read "Precautions for Replacement of Imager" of level 3 on page 4-3.

Ref. No.	Part No.	Description
51	A-1253-161-A	SY-173 BOARD, COMPLETE (SERVICE)
52	3-099-637-01	LABEL, FUSE
* 53	3-099-634-01	SHEET, ST INSULATING
* 54	3-099-636-01	SHEET, RL INSULATING
55	3-099-620-01	RETAINER, RELEASE
56	A-1246-054-A	RL-071 BOARD, COMPLETE (Note 1)
56	A-1271-235-A	RL-078 BOARD, COMPLETE (Note 1)
57	1-833-618-11	CABLE, FLEXIBLE FLAT (FFC-094)
58	X-2177-054-1	RELEASE ASSY
59	3-099-621-01	CABINET, UPPER
60	3-099-622-01	SHAFT, STRAP
61	A-1246-051-A	MC-176 BOARD, COMPLETE
* 62	3-099-639-01	SHEET, MC RADIATION
* 63	3-099-629-01	RETAINER, MULTI
* 64	3-099-635-01	SHEET, MC INSULATING

Ref. No.	Part No.	Description
65	3-099-632-01	CABINET BOTTOM (W80: SILVER)
65	3-099-632-11	CABINET BOTTOM (W80: BLACK/W85)
65	3-099-632-21	CABINET BOTTOM (W80: WHITE)
65	3-099-632-31	CABINET BOTTOM (W80: PINK)
66	3-113-705-01	SHEET (PLUS), CD RADIATION
68	A-1253-768-A	CCD BLOCK ASSY (including IC003 (CCD IMAGER) and CD-701 flexible complete board) (Note 2)
MIC901	1-542-721-11	MICROPHONE BLOCK
SP901	1-826-614-21	LOUD SPEAKER (1.0CM)
#3	2-660-401-01	SCREW (M1.7), NEW TRU-STAR, P2 (Red)
#5	3-080-204-01	SCREW, TAPPING, P2 (Black)
#30	3-086-156-11	SCREW B1.2 (White)
#65	2-635-591-01	SCREW (M1.4), NEW TRUSTAR P2 (Silver)

# 5. REPAIR PARTS LIST

## DISASSEMBLY

## HARDWARE LIST

### 5-1-3. LCD/BT HOLDER SECTION

ns: not supplied

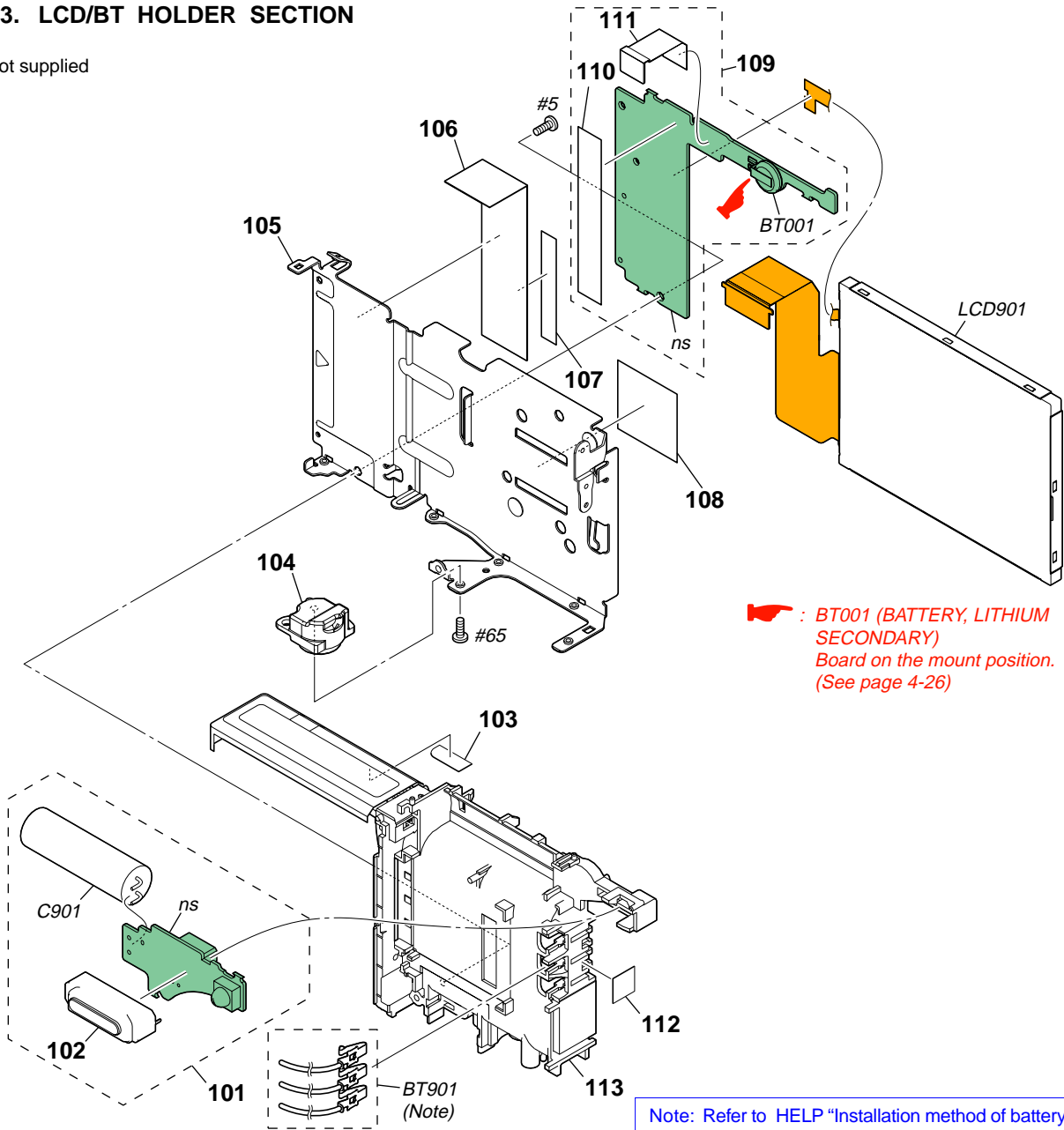

Note: Refer to HELP "Installation method of battery terminal board" when changing the service terminal (BT).

**CAUTION**

Danger of explosion if battery is incorrectly replaced.  
Replace only with the same or equivalent type.

• Refer to page 5-1 for mark △.

Ref. No.	Part No.	Description
101	A-1246-052-A	ST-160 BOARD, COMPLETE
△ 102	1-480-014-11	FLASH UNIT
* 103	3-113-323-01	LABEL, MS CAUTION
104	3-099-631-01	SCREW, TRIPOD
105	3-099-627-01	FRAME, MAIN
106	3-099-633-01	SHEET, LC FLEXIBLE
* 107	3-100-059-01	SHEET, LC FLEXIBLE ADHESIVE
* 108	3-197-557-01	SHEET, LIGHT INTERCEPTION
109	A-1246-053-A	SW-494 BOARD, COMPLETE
* 110	3-100-060-01	SHEET, SW

Ref. No.	Part No.	Description
111	1-833-616-11	CABLE, FLEXIBLE FLAT (FFC-092)
* 112	3-198-159-02	SHEET, BT TERMINAL
113	X-2177-056-1	HOLDER ASSY, BT
△ BT001	1-756-710-11	LITHIUM RECHARGEABLE BATTERY
BT901	A-1257-452-A	TERMINAL, SERVICE (BT) (Note)
△*C901	1-114-309-11	ELECT 49uF 315V
LCD901	1-802-379-11	LCD MODULE (LQ025A3DD01)
#5	3-080-204-01	SCREW, TAPPING, P2 (Black)
#65	2-635-591-01	SCREW (M1.4), NEW TRUSTAR P2 (Silver)

# 5. REPAIR PARTS LIST

## HARDWARE LIST

### 5-1-4. LENS SECTION

ns: not supplied

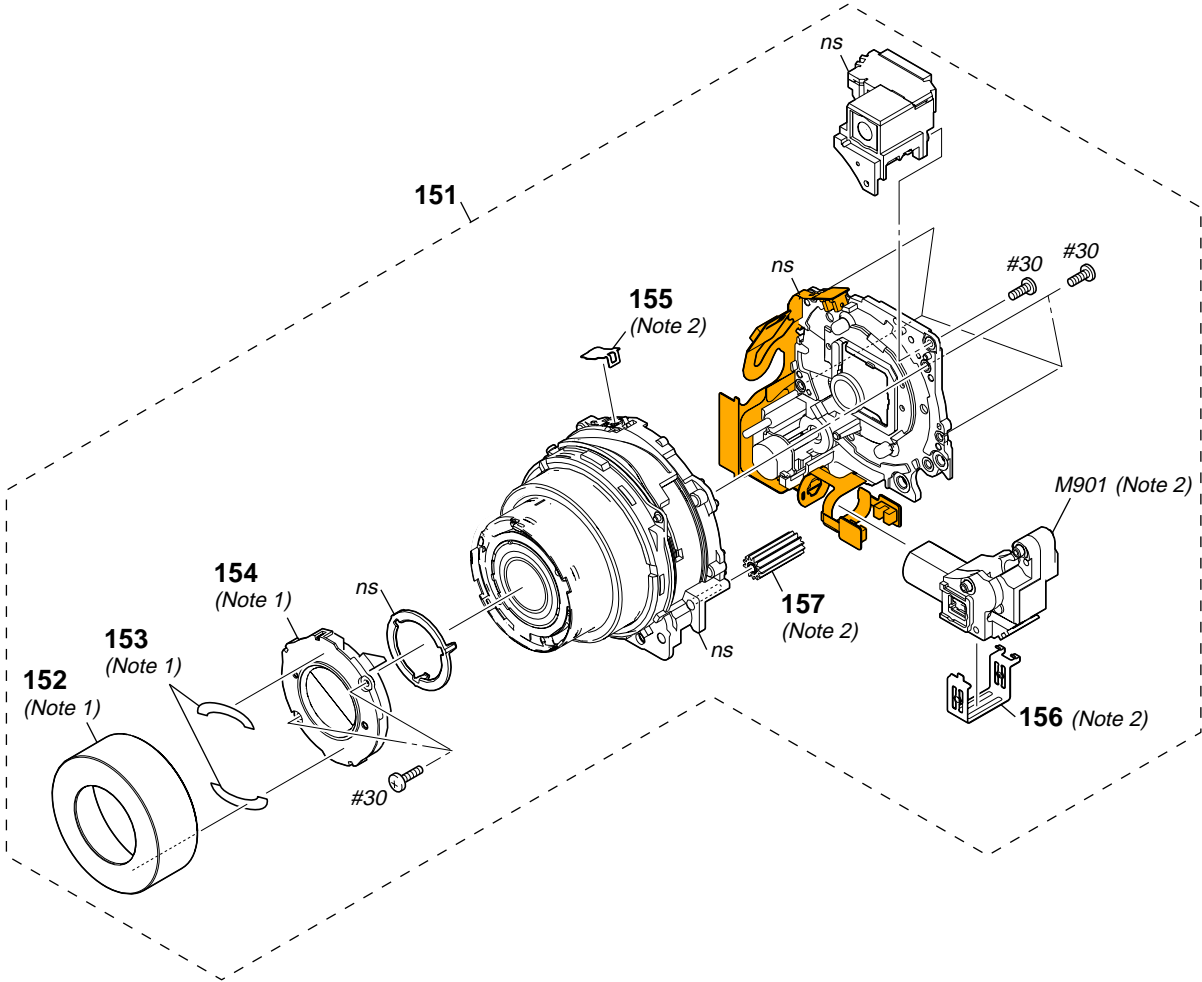

**Note 1:** Be sure to read "Exchange method of barrier block" on page 2-6.

**Note 2:** Be sure to read "Exchange method of zoom gear block" on page 2-8.

Ref. No.	Part No.	Description
151	A-1231-924-A	LSV-1160A (SERVICE)
152	2-689-851-01	RING (A), ORNAMENTAL (Note 1)
153	2-691-890-01	TAPE, BARRIER (Note 1)
154	A-1205-001-A	BARRIER BLOCK ASSY (Note 1)
155	2-689-849-01	SPRING, Z LEAF (Note 2)

Ref. No.	Part No.	Description
156	2-689-850-01	SPRING, FG LEAF (Note 2)
157	X-2177-203-1	GEAR (S), NARUTO (Note 2)
M901	1-479-864-11	GEAR BLOCK, ZOOM (1160) (Note 2)
#30	3-086-156-11	SCREW B1.2 (White)

Electrical parts list of the CD-701 board is not shown.  
Page 5-6 is not shown.

## 5-2. ELECTRICAL PARTS LIST

Ref. No.	Part No.	Description
	A-1246-051-A	MC-176 BOARD, COMPLETE ***** (Flexible flat cable (FFC-095) and CN102 are not supplied, but they are included in MC-176 complete board.)  (Not supplied) CABLE, FLEXIBLE FLAT (FFC-095)  < CONNECTOR >  CN102 (Not supplied) CONNECTOR, MULTIPLE (SOCKET) (MULTI CONNECTOR)
	A-1246-054-A	RL-071 BOARD, COMPLETE
	A-1271-235-A	RL-078 BOARD, COMPLETE *****
<div style="border: 1px solid black; padding: 5px; width: fit-content; margin: 0 auto;"> <p>Note: In this set, either RL-071 or RL-078 board is used. All mounted parts and schematic diagram are com- mon to both RL boards.</p> </div>		
	1-833-618-11	CABLE, FLEXIBLE FLAT (FFC-094)  < CAPACITOR >
C001	1-119-923-11	CERAMIC CHIP 0.047uH 10% 10V
C002	1-119-923-11	CERAMIC CHIP 0.047uH 10% 10V
		< DIODE >
D101	6-501-030-01	DIODE SML-412MWT86 (POWER)  < MICROPHONE >
MIC901	1-542-721-11	MICROPHONE BLOCK  < SWITCH >
* S101	1-786-912-21	TACTILE SWITCH (SHUTTER)
S102	1-786-885-42	SWITCH, TACTILE (POWER)
	A-1246-052-A	ST-160 BOARD, COMPLETE *****
△	1-480-014-11	FLASH UNIT  < CAPACITOR >
C001	1-100-611-91	CERAMIC CHIP 22uF 20% 6.3V
C002	1-112-717-91	CERAMIC CHIP 1uF 10% 6.3V
△ C004	1-100-758-11	CERAMIC CHIP 0.047uF 10% 250V
C007	1-164-933-11	CERAMIC CHIP 220PF 10% 50V
△*C901	1-114-309-11	ELECT 49uF 315V
		< CONNECTOR >
CN001	1-779-330-51	FFC/CONNECTOR, FPC (LIF (NON-ZIF)) 12P  < DIODE >
△*D001	6-501-433-01	DIODE MA2YF8000LS0
* D002	6-501-861-01	DIODE CL-360S-TD4-X-TL (SELF-TIMER/AF ILLUMINATOR)
D003	6-500-619-01	DIODE RB520S-40TE61

Ref. No.	Part No.	Description
		< IC >
IC001	6-707-555-01	IC TPS65552RGTR
		< COIL >
* L001	1-400-820-11	INDUCTOR 2.2uH
		< TRANSISTOR >
△*Q001	6-551-676-01	TRANSISTOR CY25BAJ-8F-T13-G12  < RESISTOR >
R002	1-218-989-11	RES-CHIP 1M 5% 1/16W
R003	1-218-941-11	RES-CHIP 100 5% 1/16W
△ R004	1-216-121-11	RES-CHIP 1M 5% 1/10W
R006	1-218-961-11	RES-CHIP 4.7K 5% 1/16W
		< TRANSFORMER >
△ T001	1-445-108-21	TRANSFORMER, D.C-D.C CONVERTER
	A-1246-053-A	SW-494 BOARD, COMPLETE ***** (S011 (mode dial) is not supplied, but this is included in SW-494 complete board.)
	1-833-616-11	CABLE, FLEXIBLE FLAT (FFC-092)
*	3-100-060-01	SHEET, SW  < LITHIUM BATTERY >
△ BT001	1-756-710-11	LITHIUM RECHARGEABLE BATTERY  < DIODE >
D001	8-719-075-29	DIODE SML-510MWT86S (AE/AF LOCK/SELF-TIMER)
D002	8-719-077-34	DIODE SML-310YTT86 (FLASH CHARGING/RECORD)  < RESISTOR >
R001	1-218-957-11	RES-CHIP 2.2K 5% 1/16W
R005	1-218-957-11	RES-CHIP 2.2K 5% 1/16W
R006	1-218-957-11	RES-CHIP 2.2K 5% 1/16W
R007	1-218-957-11	RES-CHIP 2.2K 5% 1/16W
		< COMPOSITION CIRCUIT BLOCK >
RB001	1-234-376-11	RES, NETWORK 2.2K (1005X4)
RB002	1-234-376-11	RES, NETWORK 2.2K (1005X4)
RB003	1-234-376-11	RES, NETWORK 2.2K (1005X4)
		< SWITCH >
S001	1-786-885-42	SWITCH, TACTILE (▼ (SELF-TIMER))
S002	1-786-885-42	SWITCH, TACTILE (W (ZOOM))
S003	1-786-885-42	SWITCH, TACTILE (▶)
S004	1-786-885-42	SWITCH, TACTILE (► (FLASH))
S005	1-786-885-42	SWITCH, TACTILE (T (ZOOM))
S006	1-786-885-42	SWITCH, TACTILE (▲ (DISP))
S007	1-786-885-42	SWITCH, TACTILE (MENU)
S008	1-786-885-42	SWITCH, TACTILE (◀ (MACRO))

• Refer to page 5-1 for mark △.

**CAUTION**  
Danger of explosion if battery is incorrectly replaced.  
Replace only with the same or equivalent type.

<u>Ref. No.</u>	<u>Part No.</u>	<u>Description</u>
S009	1-786-885-42	SWITCH, TACTILE (HOME)
S010	1-786-885-42	SWITCH, TACTILE (● (SET))
S011	(Not supplied)	ROTARY SWITCH (MODE DIAL)

Electrical parts list of the SY-173 board is not shown.  
Pages 5-9 to 5-13 are not shown.

**Checking supplied accessories.**

Note: This item is supplied with the unit as an accessory, but is not prepared as a service part.

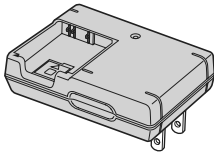

Battery Charger  
BC-CSGC  
△ 1-480-175-11 (J)  
△ 1-480-175-21 (US, CND)

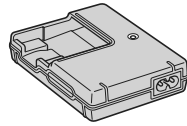

Battery Charger  
BC-CSGC  
△ 1-480-175-31 (EXCEPT US, CND, J)

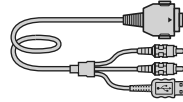

USB, A/V Cable for  
Multi-use Terminal  
1-829-866-51

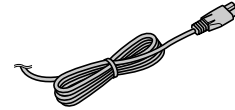

Power Cord  
△ 1-555-074-91 (AUS)  
△ 1-832-121-31 (CH)  
△ 1-833-892-21 (KR)  
△ 1-827-269-12 (UK, HK)  
△ 1-824-910-71 (AEP, E)  
△ 1-792-549-41 (JE)  
△ 1-783-952-61 (AR)

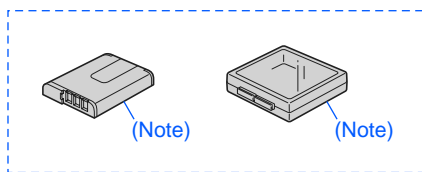

Rechargeable Battery Pack  
NP-BG1/Battery Case  
△ A-1137-161-A (J)  
△ A-1567-198-A (US, CND)  
△ A-1641-431-A (EXCEPT US, CND, J)

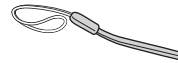

Wrist Strap (W80)  
2-050-981-01



Neck Strap (W85)  
2-674-454-31

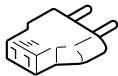

Conversion (2P) Adaptor  
△ 1-569-007-12 (JE)



Conversion (2P) Adaptor  
△ 1-569-008-12 (E: NTSC)

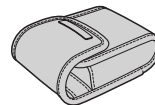

Soft Carrying Case (W85)  
3-106-988-01

• Refer to page 5-1 for mark △.

## Ver. 1.1 2008.05

The changed portions from Ver. 1.0 are shown in blue.

### Checking supplied accessories.



#### Instruction Manual

- 3-095-004-02 (JAPANESE) (W80: J)
- 3-095-004-12 (ENGLISH) (W80: CND, AEP, UK, E, HK, AUS, JE/W85: CND, AEP, UK, E, AUS)
- 3-095-004-22 (FRENCH, ITALIAN) (W80: CND, AEP/W85: CND, AEP)
- 3-095-004-32 (SPANISH, PORTUGUESE) (W80: AEP, E, AR, JE/W85: AEP, E)
- 3-095-004-42 (GERMAN, DUTCH) (W80: AEP/W85: AEP)
- 3-095-004-52 (TRADITIONAL CHINESE, SIMPLIFIED CHINESE) (W80: E, HK, CH, JE/W85: E)
- 3-095-004-62 (RUSSIAN) (W80: AEP/W85: AEP)
- 3-095-004-72 (ARABIC, PERSIAN) (W80: E/W85: E)
- 3-095-004-82 (KOREAN) (W80: KR, JE/W85: KR)
- 3-095-004-92 (POLISH, CZECH) (W80: AEP/W85: AEP)
- 3-095-005-12 (HUNGARIAN, SLOVAK) (W80: AEP/W85: AEP)
- 3-095-005-22 (SWEDISH, FINNISH) (W80: AEP/W85: AEP)
- 3-095-005-32 (NORWEGIAN, DANISH) (W80: AEP/W85: AEP)
- 3-095-005-42 (THAI, MALAY) (W80: E/W85: E)
- 3-095-005-52 (TURKISH, GREEK) (W80: AEP/W85: AEP)
- 3-095-005-62 (ENGLISH, SPANISH) (W80: US)

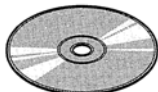

#### CD-ROM

(Cyber-shot Application Software/  
"Cyber-shot Handbook"/  
"Cyber-shot Step-up Guide")  
3-094-911-02 (EXCEPT J)  
3-198-533-02 (J)

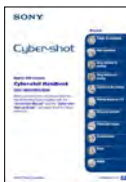

#### Cyber-shot Handbook (PDF)

The CD-ROM supplied contains all of language version of the Handycam Handbook (PDF) for printing.

- The printed matter is not supplied. If required, please order it with the part number below.

- (Only for destination Japanese model)

日本国内については日本語のみが印刷での部品供給可能です。

- |                                    |                          |
|------------------------------------|--------------------------|
| 3-094-994-02 (JAPANESE)            | 3-094-995-42 (KOREAN)    |
| 3-094-994-12 (ENGLISH)             | 3-094-995-52 (POLISH)    |
| 3-094-994-22 (FRENCH)              | 3-094-995-62 (CZECH)     |
| 3-094-994-32 (ITALIAN)             | 3-094-995-72 (HUNGARIAN) |
| 3-094-994-42 (SPANISH)             | 3-094-995-82 (SLOVAK)    |
| 3-094-994-52 (PORTUGUESE)          | 3-094-995-92 (SWEDISH)   |
| 3-094-994-62 (GERMAN)              | 3-094-996-12 (FINNISH)   |
| 3-094-994-72 (DUTCH)               | 3-094-996-22 (NORWEGIAN) |
| 3-094-994-82 (TRADITIONAL CHINESE) | 3-094-996-32 (DANISH)    |
| 3-094-994-92 (SIMPLIFIED CHINESE)  | 3-094-996-42 (THAI)      |
| 3-094-995-12 (RUSSIAN)             | 3-094-996-52 (MALAY)     |
| 3-094-995-22 (ARABIC)              | 3-094-996-62 (TURKISH)   |
| 3-094-995-32 (PERSIAN)             | 3-094-996-72 (GREEK)     |

# DSC-W80/W85

SONY®

LEVEL 2

## SERVICE MANUAL

Ver. 1.1 2008.05

*US Model  
Canadian Model  
AEP Model  
UK Model  
E Model  
Australian Model  
Hong Kong Model  
Chinese Model  
Korea Model  
Argentine Model  
Brazilian Model  
Japanese Model  
Tourist Model*

## SUPPLEMENT-1

File this supplement with the service manual.  
(D108-010)

- Change of Board's Suffix No.
- Change of Repair Parts
- Revision of Accessories

**Note:** Please refer to Ver. 1.1 of SERVICE MANUAL (9-852-194-31) for the revision of accessories.

- Suffix No. of MC-176 and ST-160 boards have been changed from **11**, **12** into **12**, **22**.  
About suffix No. **11** and **12**, **22**, there are no change of schematic diagram and printed wiring board.



## 5. REPAIR PARTS LIST

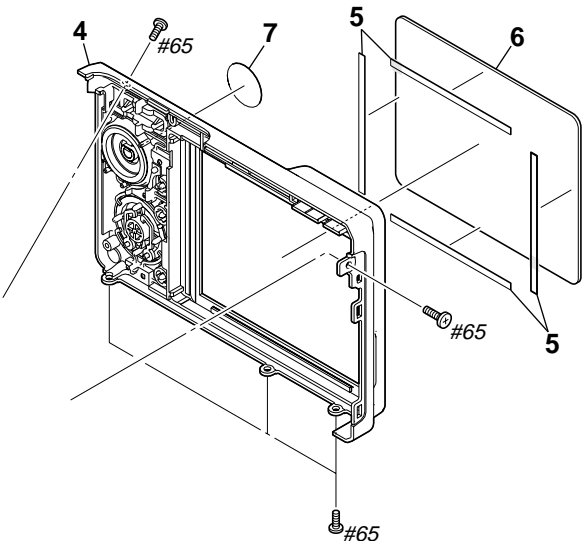
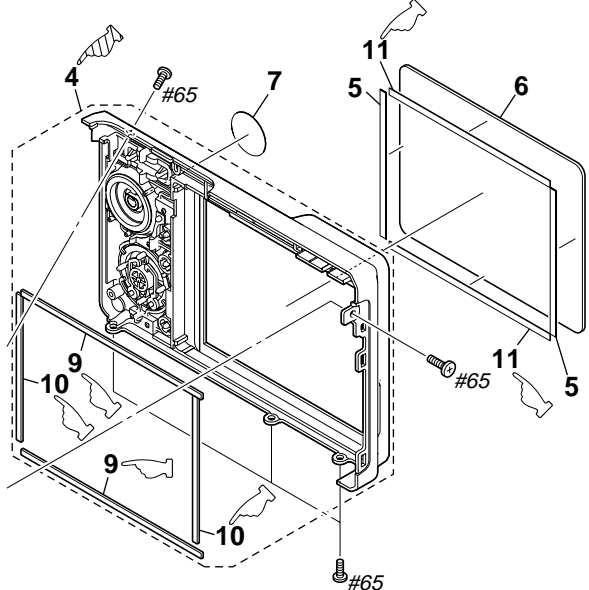

### 5-1. EXPLODED VIEWS

 : Points added portion.

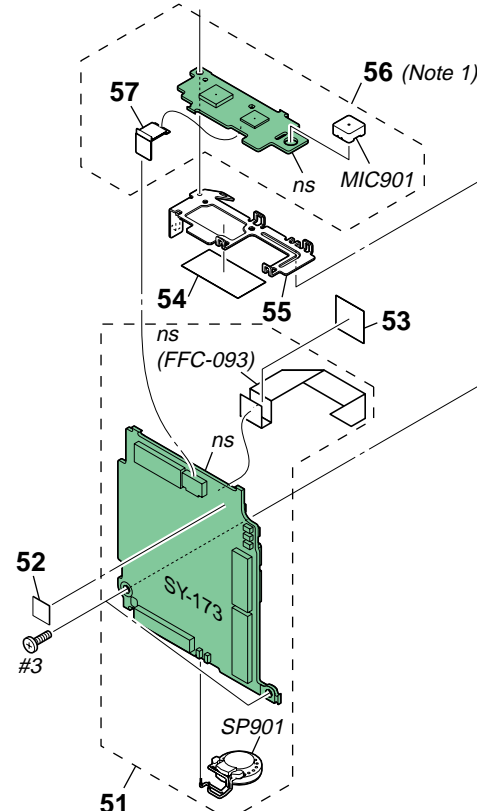
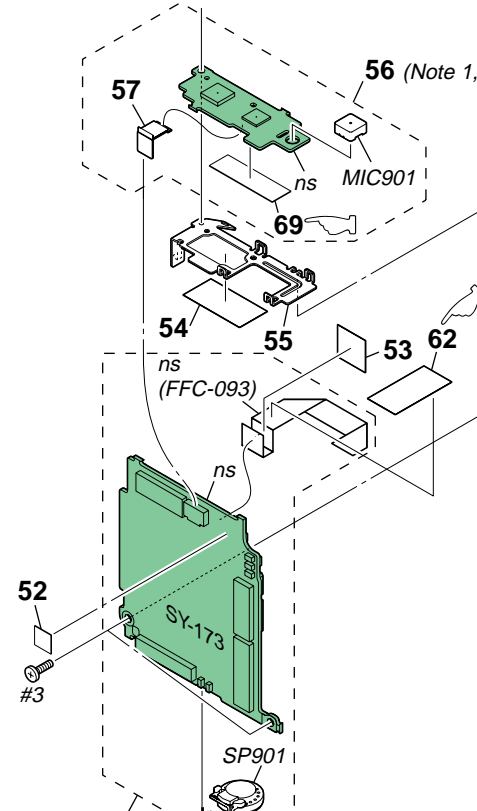

Page	Former	New																											
5-2																													
	<table style="width: 100%; border-collapse: collapse;"> <thead> <tr> <th style="text-align: left; border-bottom: 1px solid black;">Ref. No.</th> <th style="text-align: left; border-bottom: 1px solid black;">Part No.</th> <th style="text-align: left; border-bottom: 1px solid black;">Description</th> </tr> </thead> <tbody> <tr> <td style="border-bottom: 1px solid black;">5</td> <td style="border-bottom: 1px solid black;">3-099-626-01</td> <td style="border-bottom: 1px solid black;">SHEET, LCD WINDOW ADHESIVE</td> </tr> <tr> <td style="border-bottom: 1px solid black;"> </td> <td style="border-bottom: 1px solid black;"> </td> <td style="border-bottom: 1px solid black;"> </td> </tr> <tr> <td style="border-bottom: 1px solid black;"> </td> <td style="border-bottom: 1px solid black;"> </td> <td style="border-bottom: 1px solid black;"> </td> </tr> </tbody> </table>	Ref. No.	Part No.	Description	5	3-099-626-01	SHEET, LCD WINDOW ADHESIVE							<table style="width: 100%; border-collapse: collapse;"> <thead> <tr> <th style="text-align: left; border-bottom: 1px solid black;">Ref. No.</th> <th style="text-align: left; border-bottom: 1px solid black;">Part No.</th> <th style="text-align: left; border-bottom: 1px solid black;">Description</th> </tr> </thead> <tbody> <tr> <td style="border-bottom: 1px solid black;">5</td> <td style="border-bottom: 1px solid black;">3-099-626-02</td> <td style="border-bottom: 1px solid black;">SHEET, LCD WINDOW ADHESIVE</td> </tr> <tr> <td style="border-bottom: 1px solid black;">9</td> <td style="border-bottom: 1px solid black;">3-275-132-01</td> <td style="border-bottom: 1px solid black;">CUSHION (L), LCD</td> </tr> <tr> <td style="border-bottom: 1px solid black;">10</td> <td style="border-bottom: 1px solid black;">3-098-449-02</td> <td style="border-bottom: 1px solid black;">CUSHION, LCD</td> </tr> <tr> <td style="border-bottom: 1px solid black;">11</td> <td style="border-bottom: 1px solid black;">3-275-133-01</td> <td style="border-bottom: 1px solid black;">SHEET (L), LCD WINDOW ADHESIVE</td> </tr> </tbody> </table>	Ref. No.	Part No.	Description	5	3-099-626-02	SHEET, LCD WINDOW ADHESIVE	9	3-275-132-01	CUSHION (L), LCD	10	3-098-449-02	CUSHION, LCD	11	3-275-133-01	SHEET (L), LCD WINDOW ADHESIVE
Ref. No.	Part No.	Description																											
5	3-099-626-01	SHEET, LCD WINDOW ADHESIVE																											
Ref. No.	Part No.	Description																											
5	3-099-626-02	SHEET, LCD WINDOW ADHESIVE																											
9	3-275-132-01	CUSHION (L), LCD																											
10	3-098-449-02	CUSHION, LCD																											
11	3-275-133-01	SHEET (L), LCD WINDOW ADHESIVE																											

 : Points added portion.  
 : Points changed portion.

Page	Former	New																								
5-3	 <table border="1"> <thead> <tr> <th>Ref. No.</th> <th>Part No.</th> <th>Description</th> </tr> </thead> <tbody> <tr> <td>52</td> <td>3-099-637-01</td> <td>LABEL, FUSE</td> </tr> <tr> <td>56</td> <td>A-1246-054-A</td> <td>RL-071 BOARD, COMPLETE (Note 1)</td> </tr> <tr> <td>56</td> <td>A-1271-235-A</td> <td>RL-078 BOARD, COMPLETE (Note 1)</td> </tr> </tbody> </table>	Ref. No.	Part No.	Description	52	3-099-637-01	LABEL, FUSE	56	A-1246-054-A	RL-071 BOARD, COMPLETE (Note 1)	56	A-1271-235-A	RL-078 BOARD, COMPLETE (Note 1)	 <table border="1"> <thead> <tr> <th>Ref. No.</th> <th>Part No.</th> <th>Description</th> </tr> </thead> <tbody> <tr> <td>52</td> <td>3-099-637-03</td> <td>LABEL, FUSE</td> </tr> <tr> <td>56</td> <td>A-1246-054-A</td> <td>RL-071 BOARD, COMPLETE (Note 1, 2)</td> </tr> <tr> <td>* 69</td> <td>3-269-269-01</td> <td>SHEET, RL PREVENTION RUST</td> </tr> </tbody> </table> <p>Note 2: The RL-071 flexible board is compatible with the RL-078 flexible board.  When replace the RL-078 flexible board, change it to the RL-071 flexible board.</p>	Ref. No.	Part No.	Description	52	3-099-637-03	LABEL, FUSE	56	A-1246-054-A	RL-071 BOARD, COMPLETE (Note 1, 2)	* 69	3-269-269-01	SHEET, RL PREVENTION RUST
Ref. No.	Part No.	Description																								
52	3-099-637-01	LABEL, FUSE																								
56	A-1246-054-A	RL-071 BOARD, COMPLETE (Note 1)																								
56	A-1271-235-A	RL-078 BOARD, COMPLETE (Note 1)																								
Ref. No.	Part No.	Description																								
52	3-099-637-03	LABEL, FUSE																								
56	A-1246-054-A	RL-071 BOARD, COMPLETE (Note 1, 2)																								
* 69	3-269-269-01	SHEET, RL PREVENTION RUST																								
5-4	 BT001 1-756-710-11 LITHIUM RECHARGEABLE BATTERY	 BT001 1-756-711-11 LITHIUM RECHARGEABLE BATTERY																								

The components identified by mark  or dotted line with mark  are critical for safety. Replace only with part number specified.

Les composants identifiés par une marque  sont critiques pour la sécurité. Ne les remplacer que par une pièce portant le numéro spécifié.

 印の部品、または 印付の点線で囲まれた部品は、安全性を維持するために、重要な部品です。従って交換時は、必ず指定の部品を使用してください。

## 5-2. ELECTRICAL PARTS LIST

Page	Former			New		
	Ref. No.	Part No.	Description	Ref. No.	Part No.	Description
5-7		A-1246-054-A A-1271-235-A	RL-071 BOARD, COMPLETE RL-078 BOARD, COMPLETE *****		A-1246-054-A	RL-071 BOARD, COMPLETE ***** The RL-071 flexible board is compatible with the RL-078 flexible board. When replace the RL-078 flexible board, change it to the RL-071 flexible board.
			< SWITCH >	*	3-269-269-01	SHEET, RL PREVENTION RUST < SWITCH >
	S102	1-786-885-42	SWITCH, TACTILE (POWER)	S102	1-771-844-21	SWITCH, TACTILE (POWER)
5-7	<b>ST-160 Board</b>			<b>ST-160 Board</b>		
			< DIODE >			< DIODE >
	△* D001	6-501-433-01	DIODE MA2YF8000LS0	△ D001	6-501-141-01	DIODE FT02P80TP
			< TRANSISTOR >			< TRANSISTOR >
	△* Q001	6-551-676-01	TRANSISTOR CY25BAJ-8F-T13-G12	△* Q001	6-551-452-01	TRANSISTOR CY25BAJ-8F-T23-G02
5-7	<b>SW-494 Board</b>			<b>SW-494 Board</b>		
			< BATTERY >			< BATTERY >
	△ BT001	1-756-710-11	LITHIUM RECHARGEABLE BATTERY	△ BT001	1-756-711-11	LITHIUM RECHARGEABLE BATTERY
			< SWITCH >			< SWITCH >
	S001	1-786-885-42	SWITCH, TACTILE (▼ (SELF-TIMER))	S001	1-771-844-21	SWITCH, TACTILE (▼ (SELF-TIMER))
	S002	1-786-885-42	SWITCH, TACTILE (W (ZOOM))	S002	1-771-844-21	SWITCH, TACTILE (W (ZOOM))
	S003	1-786-885-42	SWITCH, TACTILE (▶)	S003	1-771-844-21	SWITCH, TACTILE (▶)
	S004	1-786-885-42	SWITCH, TACTILE (► (FLASH))	S004	1-771-844-21	SWITCH, TACTILE (► (FLASH))
	S005	1-786-885-42	SWITCH, TACTILE (T (ZOOM))	S005	1-771-844-21	SWITCH, TACTILE (T (ZOOM))
	S006	1-786-885-42	SWITCH, TACTILE (▲ (DISP))	S006	1-771-844-21	SWITCH, TACTILE (▲ (DISP))
	S007	1-786-885-42	SWITCH, TACTILE (MENU)	S007	1-771-844-21	SWITCH, TACTILE (MENU)
	S008	1-786-885-42	SWITCH, TACTILE (◀ (MACRO))	S008	1-771-844-21	SWITCH, TACTILE (◀ (MACRO))
5-8	S009	1-786-885-42	SWITCH, TACTILE (HOME)	S009	1-771-844-21	SWITCH, TACTILE (HOME)
	S010	1-786-885-42	SWITCH, TACTILE (● (SET))	S010	1-771-844-21	SWITCH, TACTILE (● (SET))

The components identified by mark △ or dotted line with mark △ are critical for safety. Replace only with part number specified.

Les composants identifiés par une marque △ sont critiques pour la sécurité. Ne les remplacer que par une pièce portant le numéro spécifié.

△印の部品、または△印付の点線で囲まれた部品は、安全性を維持するために、重要な部品です。従って交換時は、必ず指定の部品を使用してください。

# DSC-W80/W85

SONY®

## SERVICE MANUAL

Ver. 1.2 2009.03

LEVEL 2

US Model  
 Canadian Model  
 AEP Model  
 UK Model  
 E Model  
 Australian Model  
 Hong Kong Model  
 Chinese Model  
 Korea Model  
 Argentine Model  
 Brazilian Model  
 Japanese Model  
 Tourist Model

## SUPPLEMENT-2

File this supplement with the service manual.  
 (D108-382)

- Change of Repair Parts
- Revision of Accessories

**Note:** Please refer to Ver. 1.2 of SERVICE MANUAL (9-852-194-32) for the revision of accessories.

 : Points changed portion.

### 5. REPAIR PARTS LIST

#### 5-1. EXPLODED VIEWS

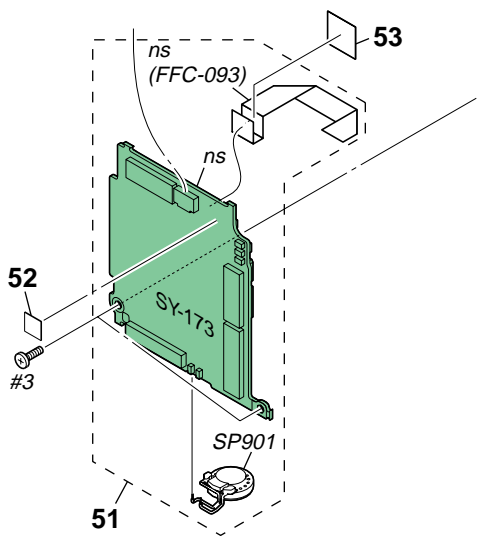
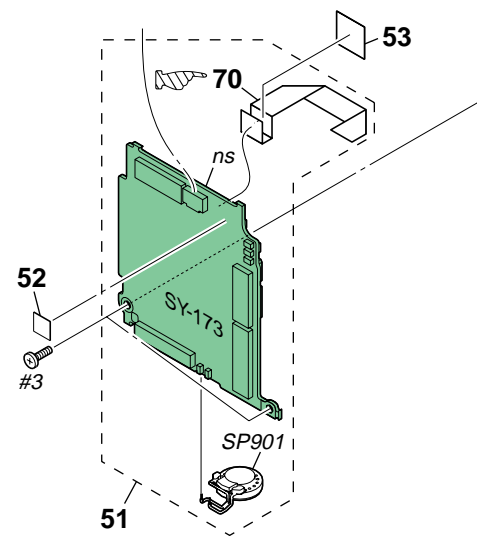
Page	Former	New												
5-3														
	<table border="1"> <thead> <tr> <th>Ref. No.</th> <th>Part No.</th> <th>Description</th> </tr> </thead> <tbody> <tr> <td></td> <td></td> <td></td> </tr> </tbody> </table>	Ref. No.	Part No.	Description				<table border="1"> <thead> <tr> <th>Ref. No.</th> <th>Part No.</th> <th>Description</th> </tr> </thead> <tbody> <tr> <td>70</td> <td>1-833-617-11</td> <td>CABLE, FLEXIBLE FLAT (FFC-093)</td> </tr> </tbody> </table>	Ref. No.	Part No.	Description	70	1-833-617-11	CABLE, FLEXIBLE FLAT (FFC-093)
Ref. No.	Part No.	Description												
Ref. No.	Part No.	Description												
70	1-833-617-11	CABLE, FLEXIBLE FLAT (FFC-093)												

## HARDWARE LIST (1/4)

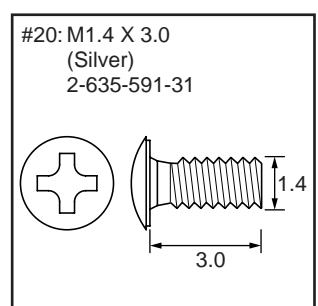
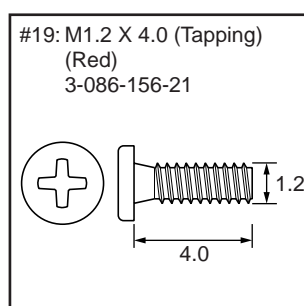
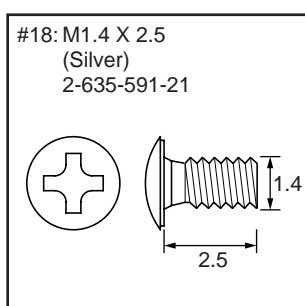
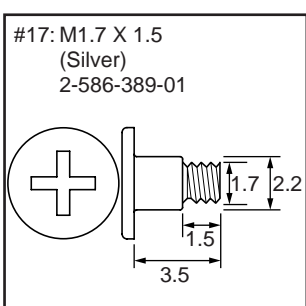
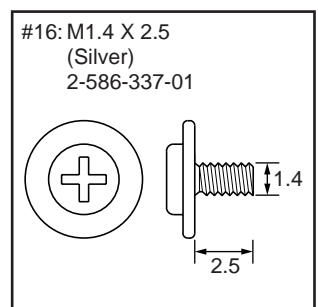
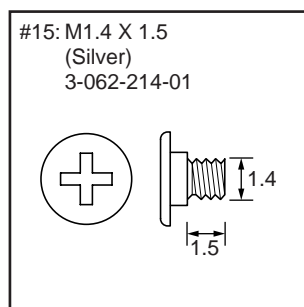
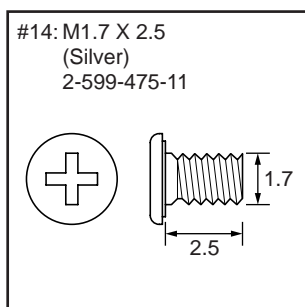
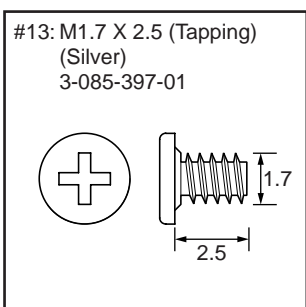
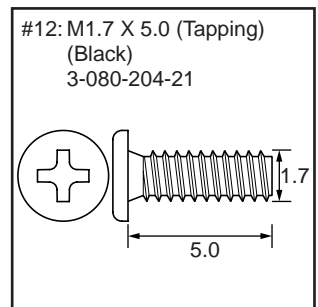
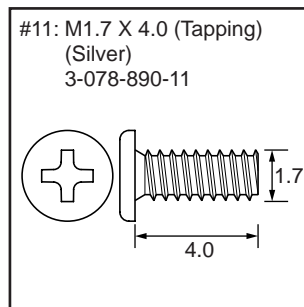
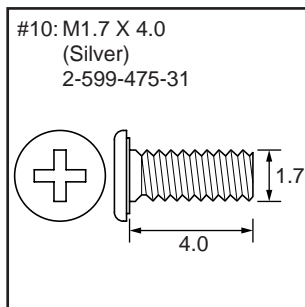
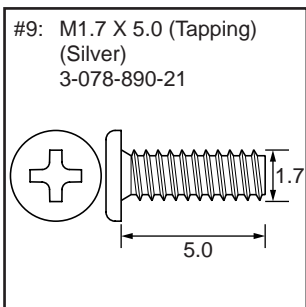
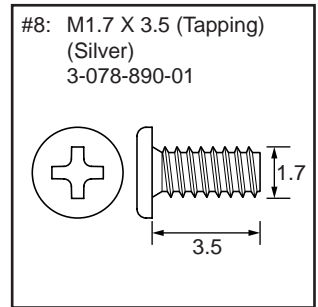
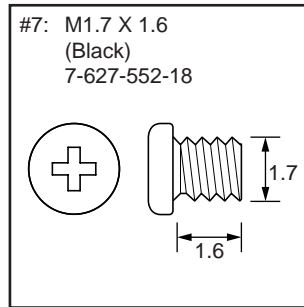
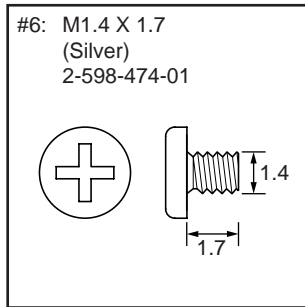
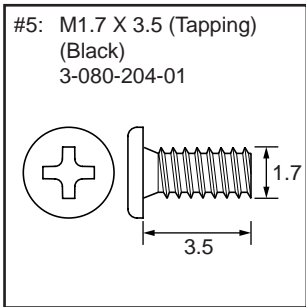
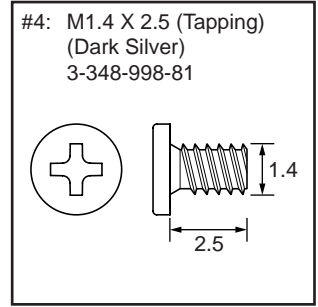
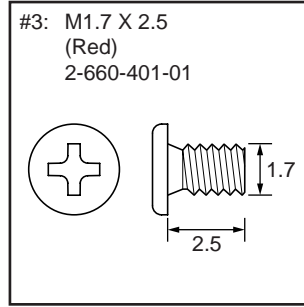
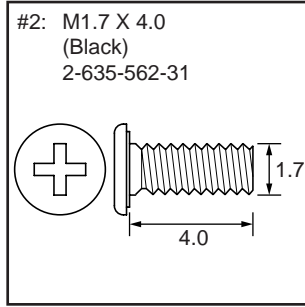
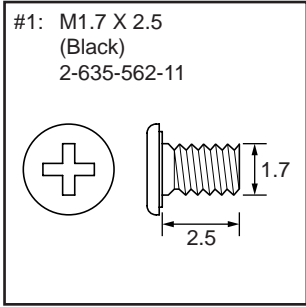

## HARDWARE LIST (2/4)

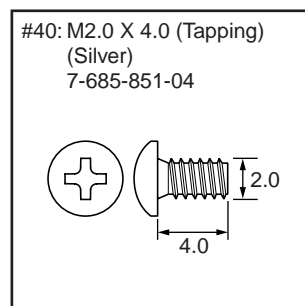
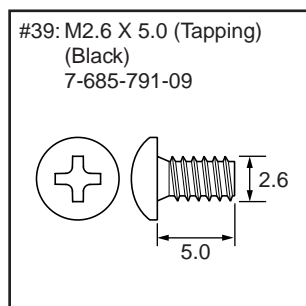
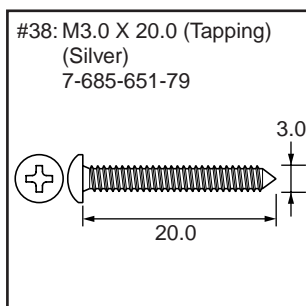
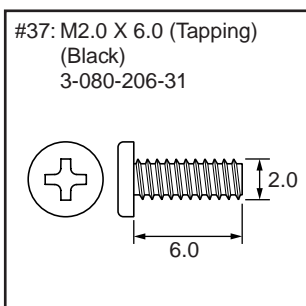
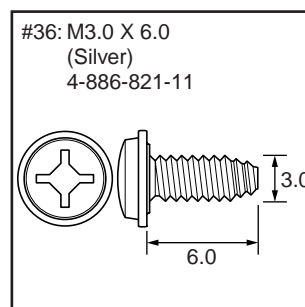
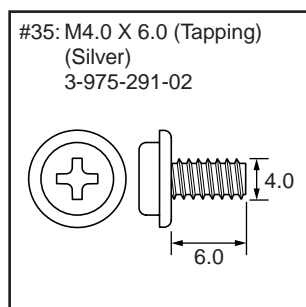
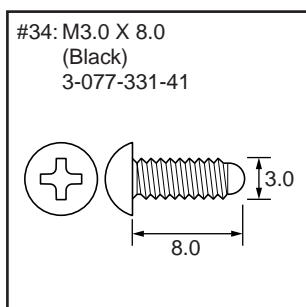
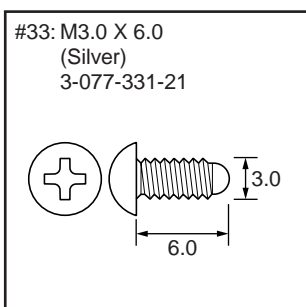
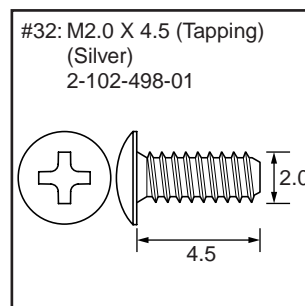
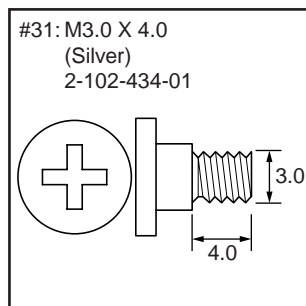
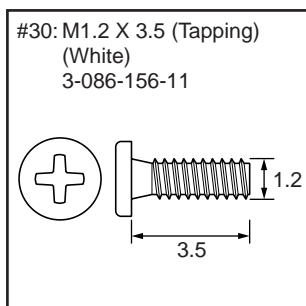
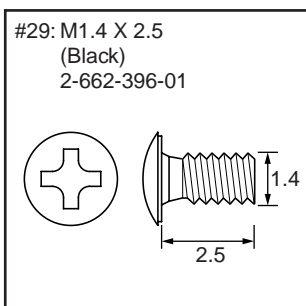
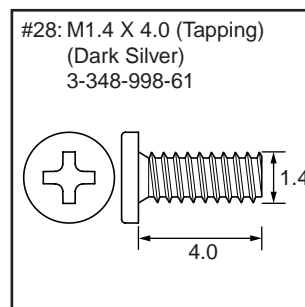
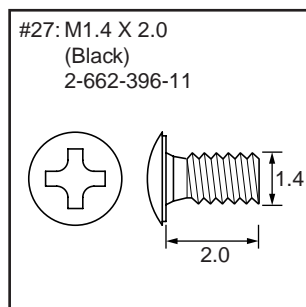
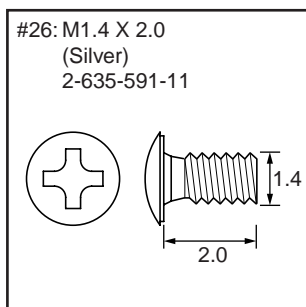
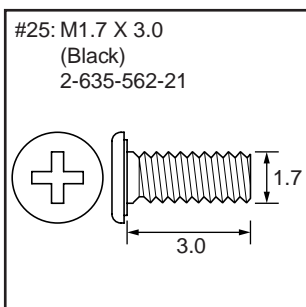
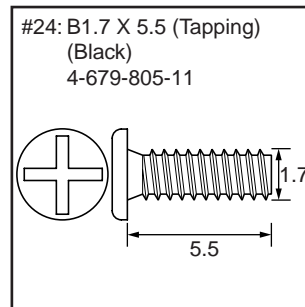
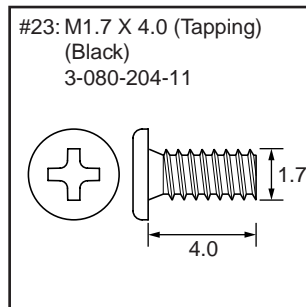
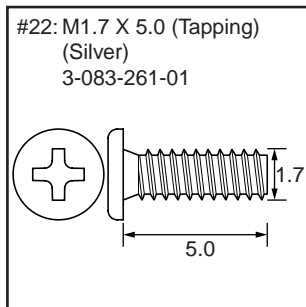
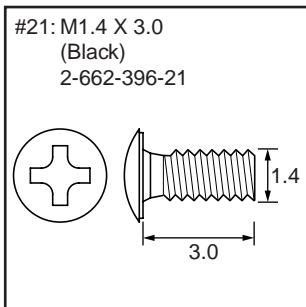

# HARDWARE LIST (3/4)

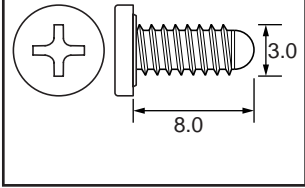
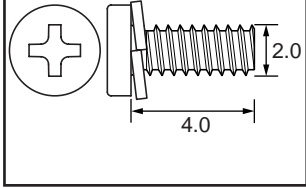
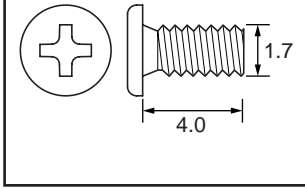
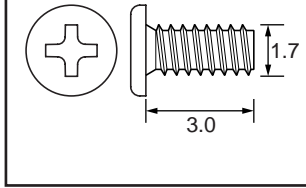
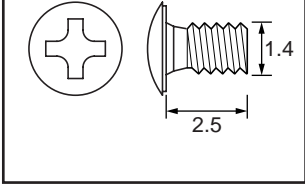
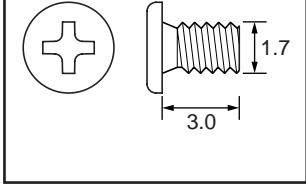
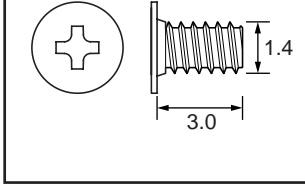
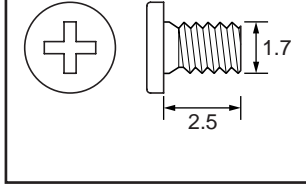
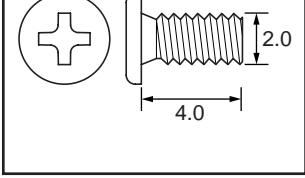
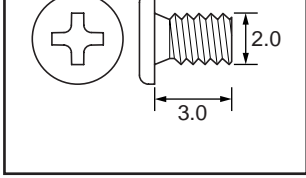
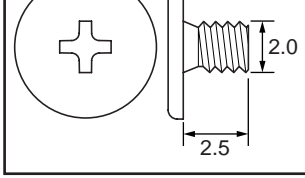
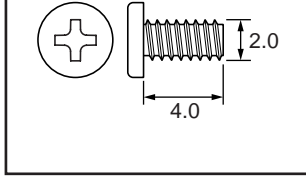
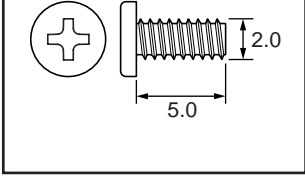
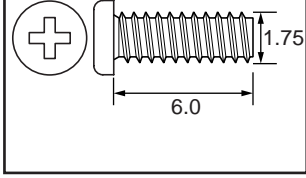
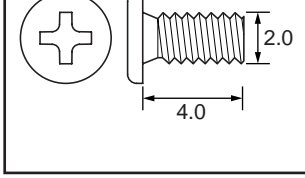
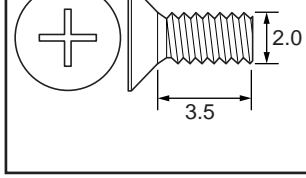
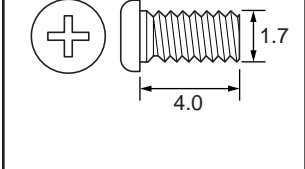
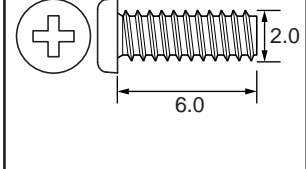
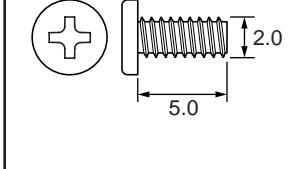
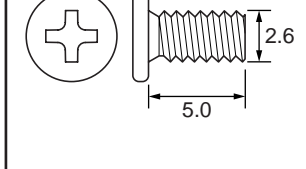
<p>#41: M3.0 X 8.0 (Tapping) (Silver) 3-065-748-01</p> 	<p>#42: M2.0 X 4.0 (Tapping) (Silver) 7-628-253-00</p> 	<p>#43: M1.7 X 4.0 (Red) 2-660-401-31</p> 	<p>#44: M1.7 X 3.0 (Tapping) (Silver) 3-078-890-61</p> 
<p>#45: M1.4 X 2.5 (Silver) 2-587-151-01</p> 	<p>#46: M1.7 X 3.0 (Red) 2-660-401-11</p> 	<p>#47: M1.4 X 3.0 (Tapping) (Silver) 2-665-774-01</p> 	<p>#48: M1.7 X 2.5 (Silver) 3-973-497-91</p> 
<p>#49: M2.0 X 4.0 (Black) 2-630-005-31</p> 	<p>#50: M2.0 X 3.0 (Red) 2-891-494-11</p> 	<p>#51: M2.0 X 2.5 (Silver) 3-073-686-01</p> 	<p>#52: M2.0 X 4.0 (Tapping) (Black) 3-080-206-11</p> 
<p>#53: M2.0 X 5.0 (Tapping) (Black) 3-080-206-21</p> 	<p>#54: M1.75 X 6.0 (Tapping) (Black) 3-318-203-11</p> 	<p>#55: M2.0 X 4.0 (Silver) 2-655-582-11</p> 	<p>#56: M2.0 X 3.5 (Silver) 3-067-187-11</p> 
<p>#57: M1.7 X 4.0 (Black) 7-627-852-18</p> 	<p>#58: M2.0 X 6.0 (Tapping) (Silver) 3-719-408-11</p> 	<p>#59: M2.0 X 5.0 (Tapping) (Silver) 3-080-205-21</p> 	<p>#60: M2.6 X 5.0 (Black) 3-061-062-11</p> 

# HARDWARE LIST (4/4)

#61: M3.0 X 10.0  
(Black)  
7-682-549-09

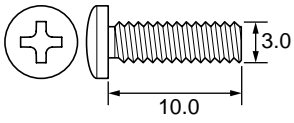

#62: M2.0 X 3.0  
(Silver)  
3-080-202-21

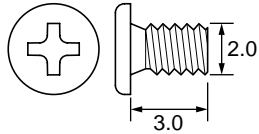

#63: M5.0 X 12.5  
(Black)  
3-060-811-21

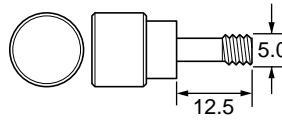

#64: M1.7 X 5.0 (Tapping)  
(Silver)  
2-666-551-21

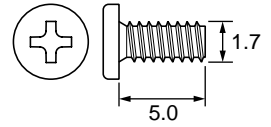

#65: M1.4 X 3.5  
(Silver)  
2-635-591-01

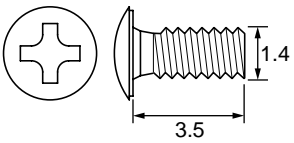

#66: M1.4 X 1.4  
(Silver)  
2-635-591-41

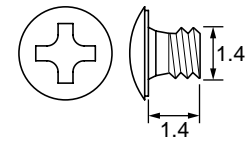

#67: M1.4 X 2.0  
(Silver)  
3-389-523-16

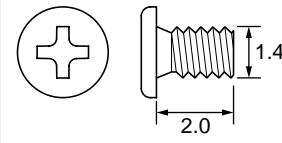

#68: M1.7 X 4.0  
(Silver)  
2-655-581-01

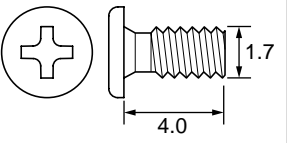

#69: M1.7 X 3.0  
(Silver)  
2-599-475-21

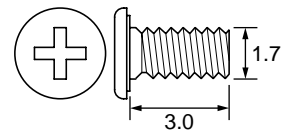

#70: M1.7 X 5.0  
(Silver)  
2-599-475-41

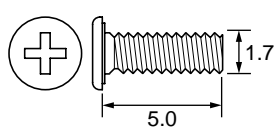

#71: M1.4 X 2.0  
(Red)  
3-208-537-01

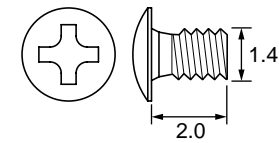

**[Description of main button functions on toolbar of the Adobe Acrobat Reader Ver5.0 (for Windows)]**

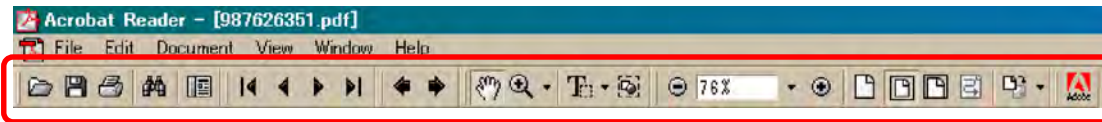

**Toolbar**



**Printing a text**

1. Click the Print button .
2. Specify a printer, print range, number of copies, and other options, and then click [OK].

**Application of printing:**

To set a range to be printed within a page, select the graphic selection tool  and drag on the page to enclose a range to be printed, and then click the Print button.

**Reversing the screens displayed once**

- To reverse the previous screens (operation) one by one, click the .
- To advance the reversed screens (operation) one by one, click the .

**Application to the Service Manual:**

This function allows you to go and back between circuit diagram and printed circuit board diagram, and accordingly it will be convenient for the voltage check.

**Finding a text**

1. Click the Find button .
2. Enter a character string to be found into a text box, and click the [Find]. (Specify the find options as necessary)

**Application to the Service Manual:**

To execute “find” from current page toward the previous pages, select the check box “Find Backward” and then click the “Find”.

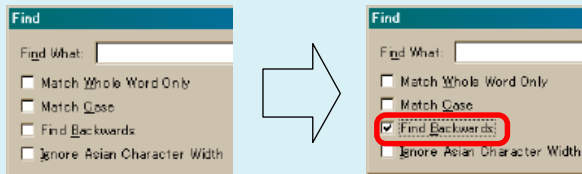





3. Open the find dialog box again, and click the [Find Again] and you can find the matched character strings displayed next. (Character strings entered previously are displayed as they are in the text box.)

**Application to the Service Manual:**

The parts on the drawing pages (block diagrams, circuit diagrams, printed circuit boards) and parts list pages in a text can be found using this find function. For example, find a Ref. No. of IC on the block diagram, and click the [Find Again] continuously, so that you can move to the Ref. No. of IC on the circuit diagram or printed circuit board diagram successively.

**Note:** The find function may not be applied to the Service Manual depending on the date of issue.

**Moving with link**

1. Select either palm tool , zoom tool , text selection tool  or graphic selection tool .
2. Place the pointer in the position in a text where the link exists (such as a button on cover and the table of contents page, or blue characters on the removal flowchart page or drawing page), and the pointer will change to the forefinger form .
3. Then, click the link. (You will go to the link destination.)

**Moving with bookmark:**

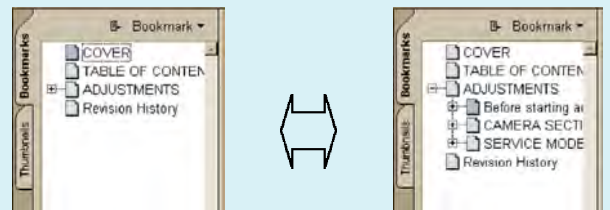

Click an item (text) on the bookmark pallet. and you can move to the link destination. Also, clicking  can display the hidden items.

(To go back to original state, click )



**Zooming or rotating the screen display**

**“Zoom in/out”**





- Click the triangle button in the zoom control box to select the display magnification. Or, you may click  or  for zooming in or out.



**“Rotate”**

- Click rotate tool , and the page then rotates 90 degrees each.

**Switching a page**

- To move to the first page, click the .
- To move to the last page, click the .
- To move to the previous page, click the .
- To move to the next page, click the .

**Application to the Service Manual:**

The printed circuit board diagram you see now can be changed to the same direction as the set.

## Revision History

Ver.	Date	History	Contents	S.M. Rev. issued
1.0	2007.03	Official Release	—	—
1.1	2008.05	<a href="#">Supplement-1</a> (S1 DI08-010)	<ul style="list-style-type: none"> <li>• Change of Board's Suffix No.</li> <li>• Change of Repair Parts</li> <li>• Correction of Self-diagnosis Code Table</li> <li>• Revision of Accessories</li> </ul> S.M. revised: <a href="#">Page 1-6</a> , <a href="#">Page 5-14</a> , <a href="#">Page 5-15</a>	Yes
1.2	2009.03	<a href="#">Supplement-2</a> (S2 DI08-382)	<ul style="list-style-type: none"> <li>• Change of Repair Parts</li> <li>• Revision of Accessories</li> </ul> S.M. revised: <a href="#">Page 5-14</a>	Yes