

# DSC-W70

## SERVICE MANUAL

LEVEL 2

Ver 1.0 2006.03

Revision History

How to use  
Acrobat Reader

Internal memory  
ON BOARD



Photo: Silver

US Model  
Canadian Model  
AEP Model  
UK Model  
E Model  
Australian Model  
Hong Kong Model  
Chinese Model  
Korea Model  
Argentine Model  
Tourist Model

### Link

<a href="#">SPECIFICATIONS</a>	<a href="#">BLOCK DIAGRAMS</a>	<a href="#">PRINTED WIRING BOARDS</a>
<a href="#">SERVICE NOTE</a>	<a href="#">FRAME SCHEMATIC DIAGRAM</a>	<a href="#">REPAIR PARTS LIST</a>
<a href="#">DISASSEMBLY</a>	<a href="#">SCHEMATIC DIAGRAMS</a>	

#### • [Precaution on Replacing the SY-156 Board](#)

The components identified by mark  $\triangle$  or dotted line with mark  $\triangle$  are critical for safety. Replace only with part number specified.

Les composants identifiés par une marque  $\triangle$  sont critiques pour la sécurité. Ne les remplacer que par une pièce portant le numéro spécifié.

DIGITAL STILL CAMERA

**SONY**<sup>®</sup>



Cyber-shot



## SPECIFICATIONS

### Camera

#### [System]

Image device	7.20 mm (1/2.5 type) color CCD, Primary color filter
Total pixel number of camera	Approx. 7 410 000 pixels
Effective pixel number of camera	Approx. 7 201 000 pixels
Lens	Carl Zeiss Vario-Tessar 3× zoom lens f = 6.3 – 18.9 mm (38 – 114 mm when converted to a 35 mm still camera) F2.8 – 5.2
Exposure control	Automatic exposure, Scene Selection (7 modes)
White balance	Automatic, Daylight, Cloudy, Fluorescent, Incandescent, Flash
File format (DCF compliant)	Still images: Exif Ver. 2.21 JPEG compliant, DPOF compatible Movies: MPEG1 compliant (Monaural)
Recording media	Internal Memory (58 MB) “Memory Stick Duo”
Flash	Recommended distance (ISO set to Auto): approx. 0.2 m to 3.7 m (7 7/8 inches to 12 feet 1 3/4 inches) (W)/approx. 0.3 m to 2.1 m (11 7/8 inches to 6 feet 10 3/4 inches) (T)

#### [Input and Output connectors]

Multi connector

#### [LCD screen]

LCD panel	6.2 cm (2.5 type) TFT drive
Total number of dots	115 200 (480×240) dots

#### [Power, general]

Power	Rechargeable battery pack NP-BG1, 3.6 V AC-LS5K AC Adaptor (not supplied), 4.2 V
Power consumption (during shooting with the LCD screen on)	1.1 W
Operating temperature	0 to 40°C (32 to 104°F)
Storage temperature	–20 to +60°C (–4 to +140°F)
Dimensions	88.9×57.1×22.9 mm (3 1/2 inches × 2 1/4 inches × 29/32 inches) (W/H/D, excluding protrusions)
Mass	Approx. 157 g (5.5 oz) (including NP-BG1 battery pack and wrist strap, etc.)
Microphone	Electret condenser microphone
Speaker	Dynamic speaker
Exif Print	Compatible
PRINT Image Matching III	Compatible
PictBridge	Compatible

#### BC-CSG battery charger

Power requirements	AC 100 to 240 V, 50/60 Hz, 2 W
Output voltage	DC 4.2 V, 0.25 A
Operating temperature	0 to 40°C (32 to 104°F)
Storage temperature	–20 to +60°C (–4 to +140°F)
Dimensions	Approx. 62 × 24 × 91 mm (2 1/2 × 31/32 × 3 5/8 inches) (W/H/D)
Mass	Approx. 75 g (2.7 oz)

#### Rechargeable battery pack NP-BG1

Used battery	Lithium-ion battery
Maximum voltage	DC 4.2 V
Nominal voltage	DC 3.6 V
Capacity	3.6 Wh (960 mAh)

Design and specifications are subject to change without notice.

**CAUTION**

Danger of explosion if battery is incorrectly replaced.  
Replace only with the same or equivalent type.

**SAFETY-RELATED COMPONENT WARNING!!**

**COMPONENTS IDENTIFIED BY MARK  $\triangle$  OR DOTTED LINE WITH MARK  $\triangle$  ON THE SCHEMATIC DIAGRAMS AND IN THE PARTS LIST ARE CRITICAL TO SAFE OPERATION. REPLACE THESE COMPONENTS WITH SONY PARTS WHOSE PART NUMBERS APPEAR AS SHOWN IN THIS MANUAL OR IN SUPPLEMENTS PUBLISHED BY SONY.**

**ATTENTION AU COMPOSANT AYANT RAPPORT À LA SÉCURITÉ!**

**LES COMPOSANTS IDENTIFÉS PAR UNE MARQUE  $\triangle$  SUR LES DIAGRAMMES SCHÉMATIQUES ET LA LISTE DES PIÈCES SONT CRITIQUES POUR LA SÉCURITÉ DE FONCTIONNEMENT. NE REMPLACER CES COMPOSANTS QUE PAR DES PIÈCES SONY DONT LES NUMÉROS SONT DONNÉS DANS CE MANUEL OU DANS LES SUPPLÉMENTS PUBLIÉS PAR SONY.**

## SAFETY CHECK-OUT

After correcting the original service problem, perform the following safety checks before releasing the set to the customer.

1. Check the area of your repair for unsoldered or poorly-soldered connections. Check the entire board surface for solder splashes and bridges.
2. Check the interboard wiring to ensure that no wires are "pinched" or contact high-wattage resistors.
3. Look for unauthorized replacement parts, particularly transistors, that were installed during a previous repair. Point them out to the customer and recommend their replacement.
4. Look for parts which, through functioning, show obvious signs of deterioration. Point them out to the customer and recommend their replacement.
5. Check the B+ voltage to see it is at the values specified.
6. FLEXIBLE Circuit Board Repairing
  - Keep the temperature of the soldering iron around 270°C during repairing.
  - Do not touch the soldering iron on the same conductor of the circuit board (within 3 times).
  - Be careful not to apply force on the conductor when soldering or unsoldering.

### Unleaded solder

Boards requiring use of unleaded solder are printed with the lead-free mark (LF) indicating the solder contains no lead. (Caution: Some printed circuit boards may not come printed with the lead free mark due to their particular size.)



### : LEAD FREE MARK

Unleaded solder has the following characteristics.

- Unleaded solder melts at a temperature about 40°C higher than ordinary solder.  
Ordinary soldering irons can be used but the iron tip has to be applied to the solder joint for a slightly longer time.  
Soldering irons using a temperature regulator should be set to about 350°C.  
Caution: The printed pattern (copper foil) may peel away if the heated tip is applied for too long, so be careful!
- Strong viscosity  
Unleaded solder is more viscous (sticky, less prone to flow) than ordinary solder so use caution not to let solder bridges occur such as on IC pins, etc.
- Usable with ordinary solder  
It is best to use only unleaded solder but unleaded solder may also be added to ordinary solder.

## TABLE OF CONTENTS

<u>Section</u>	<u>Title</u>	<u>Page</u>
<b>1. SERVICE NOTE</b>		
1-1.	Description on Self-diagnosis Display .....	1-1
1-2.	Process After Fixing Flash Error .....	1-1
1-3.	Method for Copying or Erasing the Data in Internal Memory .....	1-2
1-4.	Precaution on Replacing the SY-156 Board .....	1-3
<b>2. DISASSEMBLY</b>		
2-1.	Disassembly .....	2-2
2-2.	Exchange Method of Barrier Assy .....	2-6
2-3.	Exchange Method of Zoom Motor Unit .....	2-9
<b>3. BLOCK DIAGRAMS</b>		
3-1.	Overall Block Diagram (1/2) .....	3-1
3-2.	Overall Block Diagram (2/2) .....	3-2
3-3.	Power Block Diagram .....	3-3
<b>4. PRINTED WIRING BOARDS AND SCHEMATIC DIAGRAMS</b>		
4-1.	Frame Schematic Diagram .....	4-1
4-2.	Schematic Diagrams .....	4-3
4-3.	Printed Wiring Boards .....	4-17
4-4.	Mounted Parts Location .....	4-26
<b>5. REPAIR PARTS LIST</b>		
5-1.	Exploded Views .....	5-2
5-2.	Electrical Parts List .....	5-6

# 1. SERVICE NOTE

## 1-1. DESCRIPTION ON SELF-DIAGNOSIS DISPLAY

### Self-diagnosis display

The camera has a self-diagnosis display. This function displays the camera condition with five-digits (a combination of a letter and figures) on the LCD screen. If this occurs check the following code chart. The five-digits display informs you of the camera's current condition. The last two digits (indicated by □□) will differ depending on the state of the camera.

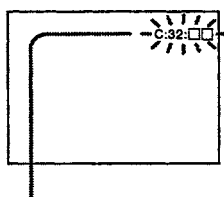

#### Self-diagnosis display

- C: □□: □□

You can reverse the camera malfunction yourself. (However, contact your Sony dealer or local authorized Sony service facility when you cannot recover from the camera malfunction.)

- E: □□: □□

Contact your Sony dealer or local authorized Sony service facility.

Display Code	Countermeasure	Cause	Caution Display During Error
C:32:□□	Turn the power off and on again.	Trouble with hardware.	SYSTEM ERROR
C:13:□□	Format the "Memory Stick" or internal memory.	"Memory Stick" or internal memory is unformatted.	FORMAT ERROR
	Insert a new "Memory Stick".	"Memory Stick" is broken.	MEMORY STICK ERROR
	Turn the power off and on again.	Trouble with internal memory.	INTERNAL MEMORY ERROR
E:61:□□	Checking of lens drive circuit.	When failed in the focus and zoom initialization.	—
E:91:□□	Checking of flash unit or replacement of flash unit. (Note)	Abnormality when flash is being charged.	

**Note:** After repair, be sure to perform "1-2. PROCESS AFTER FIXING FLASH ERROR".

## 1-2. PROCESS AFTER FIXING FLASH ERROR

When "FLASH error" (Self-diagnosis Code E : 91 : \*\* ) occurs, to prevent any abnormal situation caused by high voltage, setting of the flash is changed automatically to disabling charge and flash setting.

After fixing, this setting needs to be deactivated. Flash error code can be initialized by the operations on the Setup screen.

### Method for Initializing the Flash Error Code

#### Initialize

Initializes the setting to the default setting.

<input type="checkbox"/>	OK	See the following procedure.
<input checked="" type="checkbox"/>	Cancel	Cancels the resetting.

① Select [OK] with ▲ on the control button, then press ●.  
The message "Initialize all settings Ready?" appears.

② Select [OK] with ▲, then press ●.  
The settings are reset to the default setting.

- Make sure that the power is not disconnected during resetting.

### 1-3. METHOD FOR COPYING OR ERASING THE DATA IN INTERNAL MEMORY

The data can be copied/erased by the operations on the Setup screen. (When erasing the data, execute formatting the internal memory.)

**Note 1:** When replacing the SY-156 board, erase the data in internal memory of the board before replacement.

**Note 2:** When replacing the SY-156 board, execute formatting and initialize the internal memory after replacement.

#### Method for Copying the Data in Internal Memory



##### Copy

Copies all images in the internal memory to a "Memory Stick Duo".

<input type="checkbox"/>	OK	See the following procedure.
<input checked="" type="checkbox"/>	Cancel	Cancels the copying.

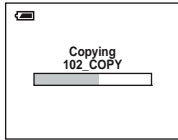
- ① Insert a "Memory Stick Duo" having 64 MB or larger capacity.
- ② Select [OK] with ▲ on the control button, then press ●.  
The message "All data in internal memory will be copied Ready?" appears.
- ③ Select [OK] with ▲, then press ●.  
Copying starts.



- Use a fully charged battery pack or the AC Adaptor (not supplied). If you attempt to copy image files using a battery pack with little remaining charge, the battery pack may run out, causing copying to fail or possibly corrupting the data.
- You cannot copy individual images.
- The original images in the internal memory are retained even after copying. To delete the contents of the internal memory, remove the "Memory Stick Duo" after copying, then execute the [Format] command in  (Internal Memory Tool).
- You cannot select a folder copied on a "Memory Stick Duo".
- Even if you copy data, a  (Print order) mark is not copied.

#### Method for Formatting the Internal Memory

This item does not appear when a "Memory Stick Duo" is inserted in the camera.  
The default settings are marked with .

##### Format

Formats the internal memory.

- Note that formatting irrevocably erases all data in the internal memory, including even protected images.

<input type="checkbox"/>	OK	See the following procedure.
<input checked="" type="checkbox"/>	Cancel	Cancels the formatting.

- ① Select [OK] with ▲ on the control button, then press ●.  
The message "All data in internal memory will be erased Ready?" appears.
- ② Select [OK] with ▲, then press ●.  
The format is complete.

## 1-4. PRECAUTION ON REPLACING THE SY-156 BOARD

### VIDEO OUT Default Data Check

When you replace to the repairing board, the written data of repairing board also might be changed to original setting because of broadcast system (NTSC/PAL).

When the data has changed because of board replacing etc., check the default data of VIDEO OUT if destination code is right. If not, rewrite to the right value.

#### VIDEO OUT Default Data

Page	Address	Data	
		NTSC	PAL
4F	8D	00	01

#### Writing Method:

- 1) Select page: 00, address: 01, and set data: 01.
- 2) Select page: 4F, address: 8D, and set data: 00 (NTSC) or data: 01 (PAL).
- 3) Select page: 40, address: 38, and set data: 00.
- 4) Click **Save** on the SEUS screen.
- 5) Select page: 80, address: 34, and check that the data is "00".
- 6) Select page: 80, address: 30, and check that the data is "00".
- 7) Select page: 00, address: 01, and set data: 00.

### Initial Language Data Check

If the SY-156 board was replaced, initial language setting may be changed. Accordingly, change the following data so as to set same initial language as that of the set distributing in each region.

Initial language: Language displayed at the next starting if the setting of Setup menu was reset.

It is different from the language setting selectable with the menu.

#### Initial Language Data

Page	Address	Data	Language	GP2	GP3	GP4
4F	8C	00	English	●	●	●
		04	Spanish		●	●
		08	Simplified Chinese			●
		0B	Russian		●	
		0D	Korean			●

**Note:** GP2 is fixed to English.

GP3 is either English, Spanish, or Russian.

GP4 is either English, Spanish, Simplified Chinese, or Korean.

#### Writing Method:

- 1) Select page: 00, address: 01 and set data: 01.
- 2) Select page: 4F, address: 8C, and set the Initial Language Data.
- 3) Select page: 40, address: 38, and set data: 00.
- 4) Click **Save** on the SEUS screen.
- 5) Select page: 80, address: 34, and check that the data is "00".
- 6) Select page: 80, address: 30, and check that the data is "00".
- 7) Select page: 00, address: 01, and set data: 00.
- 8) Turn off the camera.
- 9) Turn on the camera. Execute "Initialize" of Setup screen.
- 10) Check the language displayed when the camera starts.

## 2. DISASSEMBLY

### NOTE FOR REPAIR

- Make sure that the flat cable and flexible board are not cracked or bent at the terminal. Do not insert the cable insufficiently nor crookedly.
- When remove a connector, don't pull at wire of connector. It is possible that a wire is snapped.
- When installing a connector, don't press down at wire of connector. It is possible that a wire is snapped.
- Do not apply excessive load to the gilded flexible board.

Cut and remove the part of gilt which comes off at the point.  
(Be careful or some pieces of gilt may be left inside)

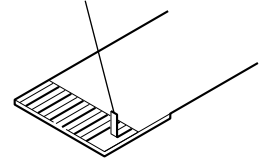

### DISCHARGING OF THE ST-133 BOARD'S CHARGING CAPACITOR (C901)

The charging capacitor (C901) of the ST-133 board is charged up to the maximum 300 V potential. There is a danger of electric shock by this high voltage when the capacitor is handled by hand. The electric shock is caused by the charged voltage which is kept without discharging when the main power of the unit is simply turned off. Therefore, the remaining voltage must be discharged as described below.

#### Preparing the Short Jig

To preparing the short jig, a small clip is attached to each end of a resistor of 1 k $\Omega$  /1 W (1-215-869-11). Wrap insulating tape fully around the leads of the resistor to prevent electrical shock.

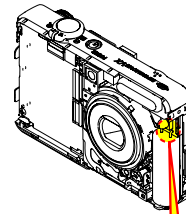
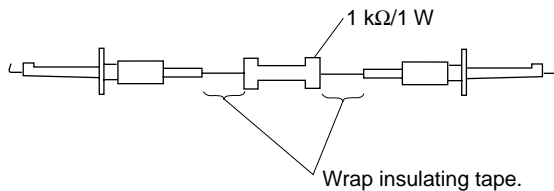

**Note:** High-voltage cautions

**Discharging the Capacitor**  
Short-circuit between the two points with the short jig about 10 seconds.

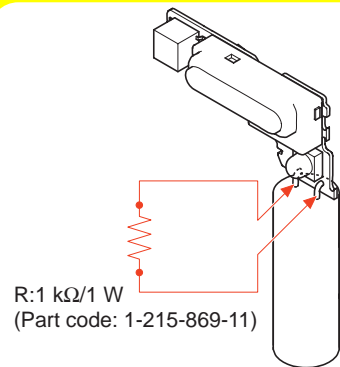

## 2-1. DISASSEMBLY

**EXPLODED VIEW**

**HARDWARE LIST**

### 2-1-1. CABINET BLOCK

Follow the disassembly in the numerical order given.

- ① Cabinet (Front) Block Assy (①-1 to ①-9)
- ② Cabinet (Rear) Block Assy (②-1 to ②-6)

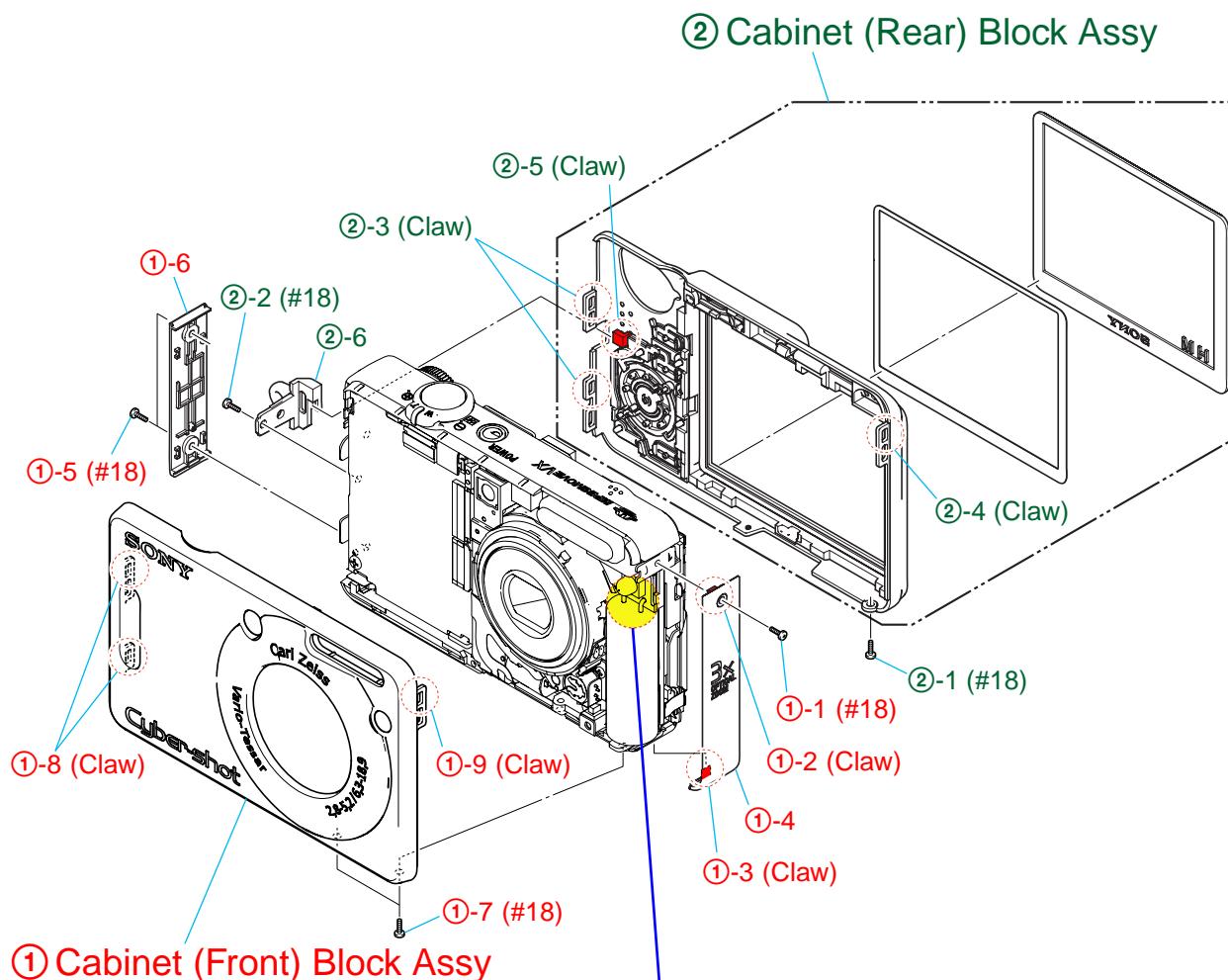

### ① Cabinet (Front) Block Assy

Refer to page 2-1  
 " Discharging of the ST-133 board's charging capacitor (C901) ",  
 when discharging the capacitor.

## 2-1-2. LCD BLOCK

Follow the disassembly in the numerical order given.

- ① LCD Block (①-1 to ①-5)
- ② SW-464 Board (②-1 to ②-6)
- ③ Cabinet (Upper) Block Assy (③-1 to ③-3)

EXPLODED VIEW

HARDWARE LIST

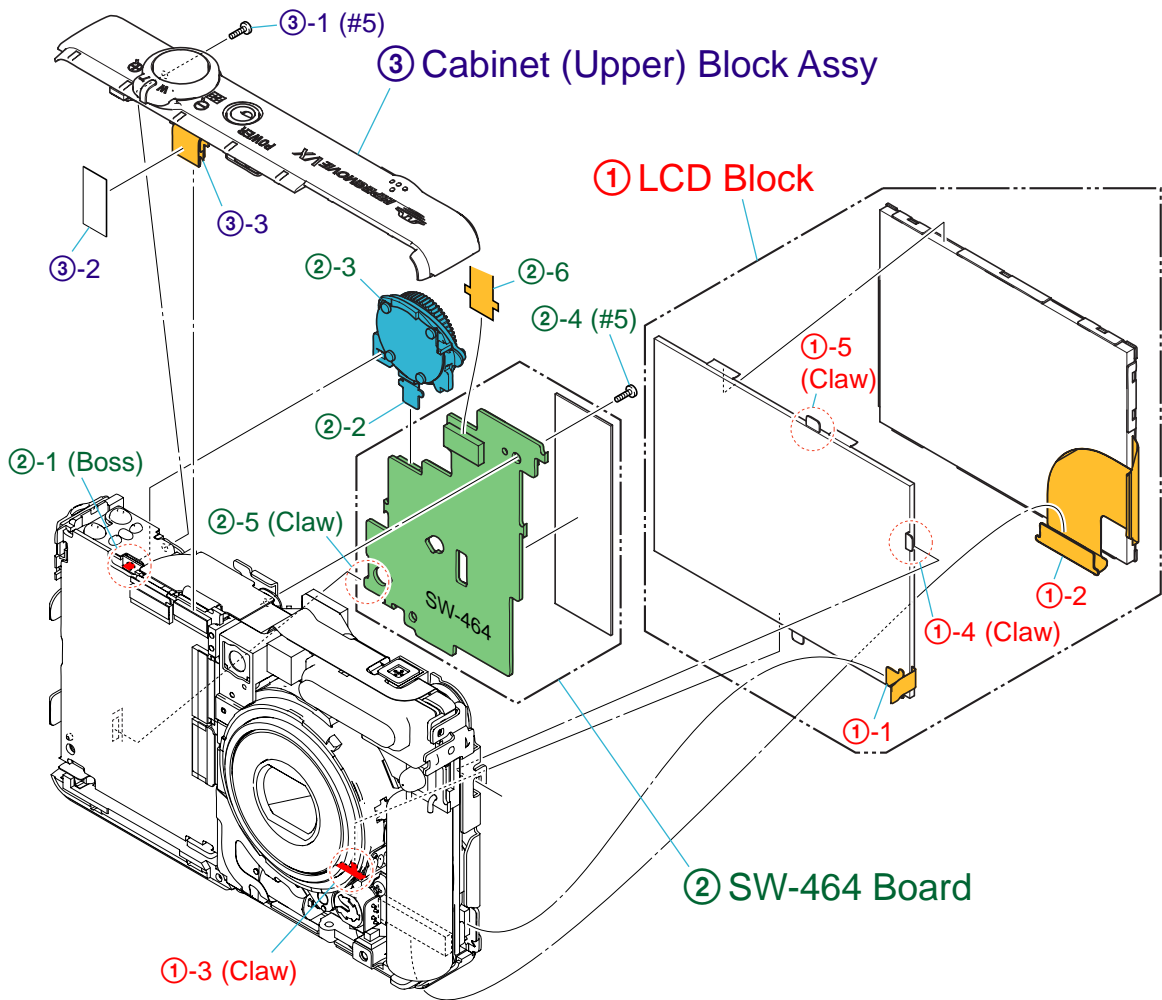

### 2-1-3. LENS BLOCK

Follow the disassembly in the numerical order given.

- ① ST-133 Board (①-1 to ①-7)
- ② Lens Unit (②-1 to ②-5)

EXPLODED VIEW

HARDWARE LIST

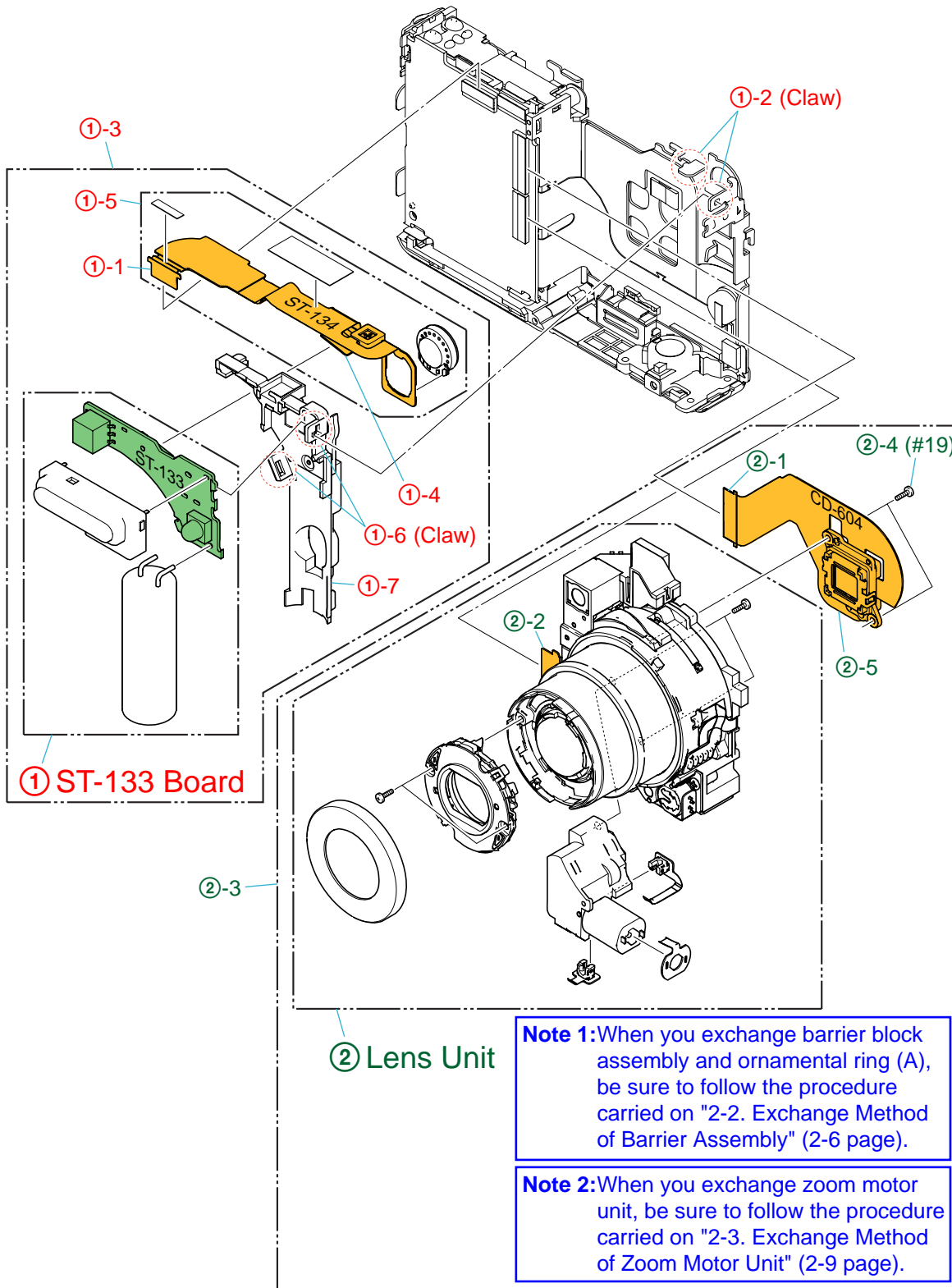

## 2-1-4. BT HOLDER BLOCK

Follow the disassembly in the numerical order given.

- ① SY-156 Board (①-1 to ①-5)
- ② JK-303 Flexible Board (②-1 to ②-4)
- ③ DC-104 Flexible Board (③-1 to ③-6)

EXPLODED VIEW

HARDWARE LIST

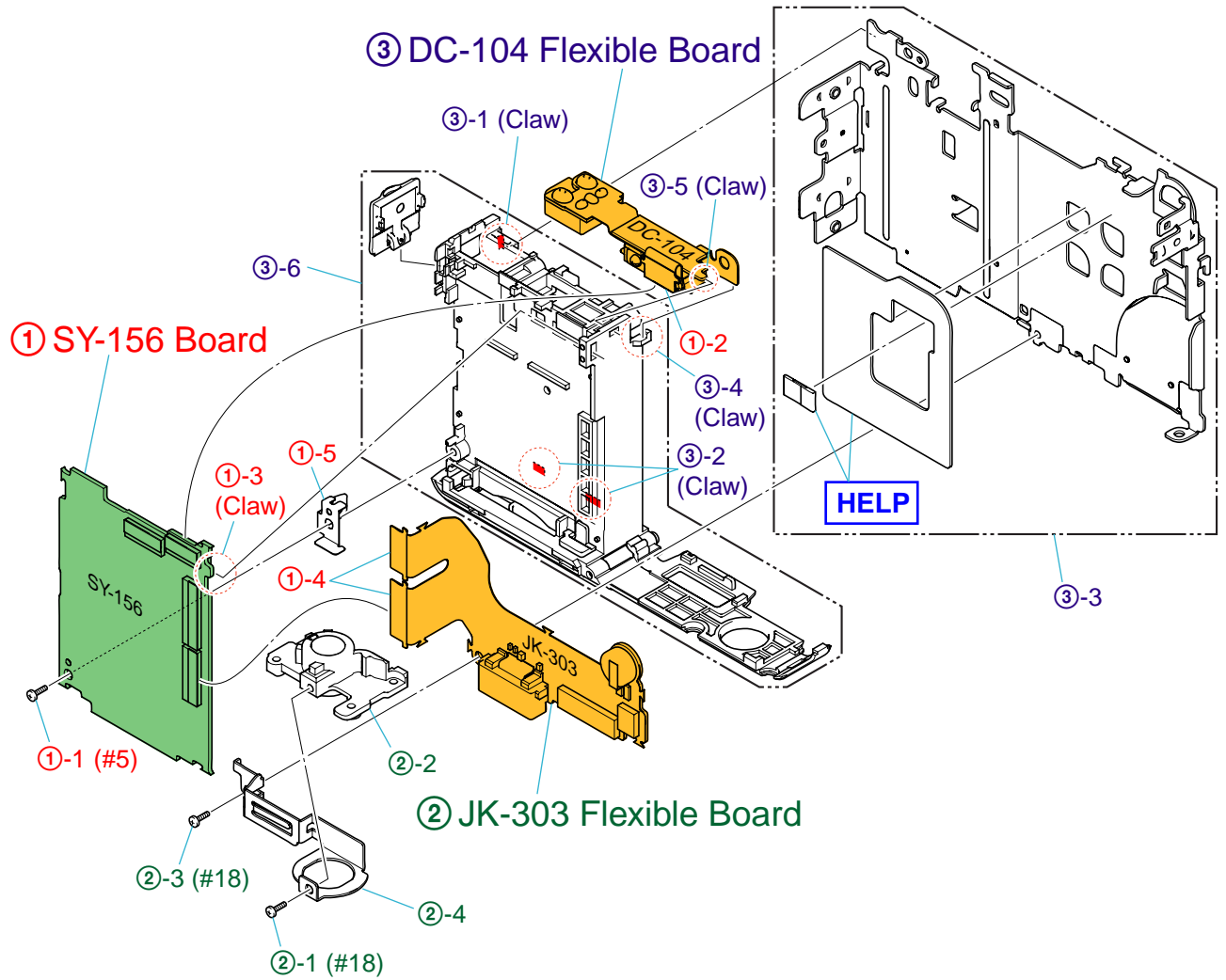

## 2-2. EXCHANGE METHOD OF BARRIER ASSY

### Service parts

	Part Number	Part Name	Quantity
1	2-673-650-01	Ring (A), Ornamental	1
2	2-673-652-01	Barrier Assy	1
3	2-673-651-01	Tapping screw (B1.2×4)	2

### Tools used

Torque driver

Soldering iron

Weight about 60g

Adhesive tape (ornamental ring fixed) (2-677-885-01)

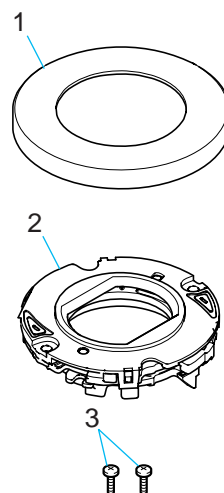

### 2-2-1. PEEL OFF OLD ORNAMENTAL RING A

The Ornamental Ring A has adhered to the Barrier Assy strongly and accordingly, use a soldering iron to weaken the adhesive force.

Heat four circled portions with the soldering iron.

Heating temperature is about 300°C.

Beware of a burn since the entire Ornamental Ring becomes hot.

\* As the adhesive force of Ornamental Ring A is considerably large, the forced peeling will damage the group-1 frame.

Insert the tip of tweezers, etc. into a notch of the group-1 frame and prize the ring.

\* Take extreme care so as not to damage the coated surface of the group-1 frame.

In case of difficult peeling, heat the ring again with the soldering iron.

If this re-heating failed, it may be advisable that the ring be peeled while heating the portions ① → ② → ③ → ④ in the under figure one by one sequentially.

\* Discard the removed Ornamental Ring A.

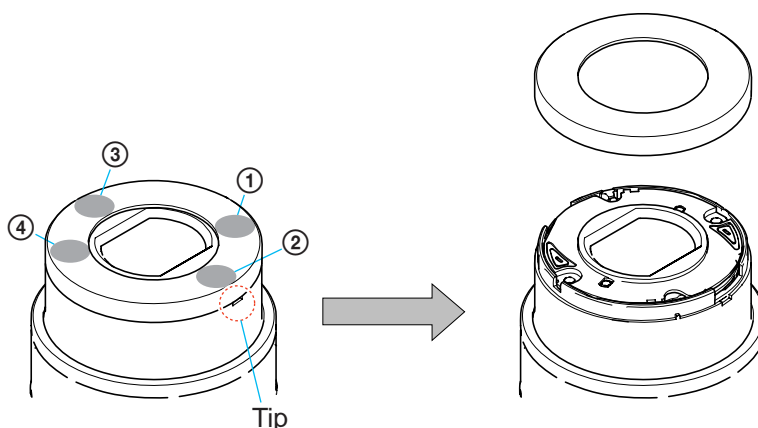

## 2-2-2. REMOVE OLD BARRIER ASSY

- ① Remove two screws.  
\* Discard the removed screws.
- ② Remove the Barrier Assy.  
\* Discard the removed Barrier Assy.

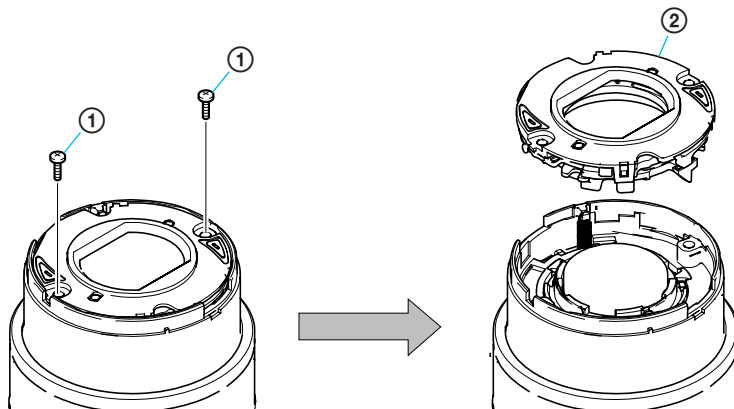

- \* After removing the Barrier Assy, if the "G1 Dust-Proof Ring" was removed, it must be returned to the home position. In returning the ring, adjust the location of a projection to the lens direction. This is an important part to prevent the dust and light from coming in.
- \* After removing the Barrier Assy, take extreme care not to drop dust or foreign substances in the lens barrel.

## 2-2-3. INSTALL NEW BARRIER ASSY

- ① Install new Barrier Assy.
- ② Tighten two screws.  
\* Tightening torque = 0.5 kgf

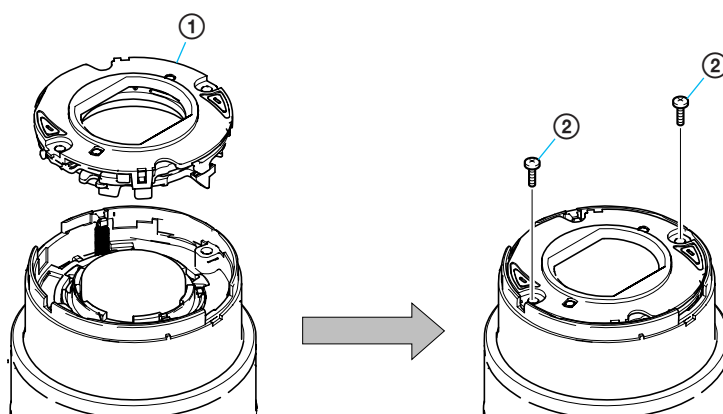

## 2-2-4. ADHERE THE ORNAMENTAL RING A

Apply an adhesive tape to four recesses on the top surface of the Barrier Assy.

Meeting a “notch” of the Ornamental Ring A with a “projection” of the group-1 frame, push the Ornamental Ring A into the group-1 frame.

\* The projection of the spring for preventing static electricity must be tilted.

Put the 60g weight on the Ornamental Ring A so that the Ornamental Ring A does not float up until the adhesive hardens.

**Note:** Be careful not to give a shock.

\* After the weight was put, no gap must be present in full circumference between Ornamental Ring A and group-1 frame.

A gap, if present, causes the crackle sound NG.

\* The weight must push in the Ornamental Ring A only.

If the weight is put on the mold part of the Barrier Assy, the Ornamental Ring A will float up.

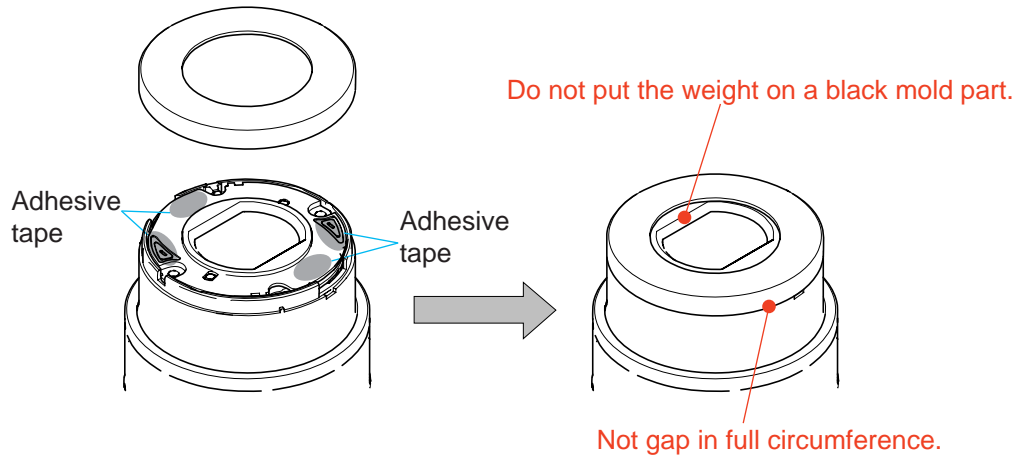

Completion after 30 minutes.

## 2-3. EXCHANGE METHOD OF ZOOM MOTOR UNIT

### Service parts

	Part Number	Part Name	Quantity
1	2-673-648-01	Zoom Motor Unit	1
2	2-673-649-01	BT2 P1.4×3 B3C	2

### Tools used

Torque driver

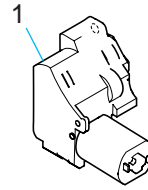

### 2-3-1. REMOVE OLD ZOOM MOTOR UNIT

- ① Remove two screws.  
\* Discard the removed screws.
- ② Remove the Zoom Motor Unit.
- ③ Remove the Lens Flexible Board.  
\* Discard the removed Zoom Motor Unit.

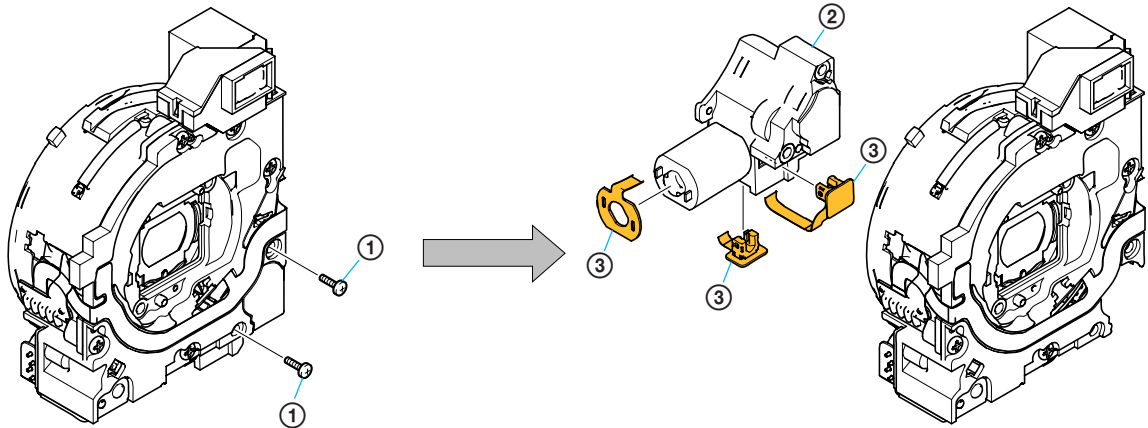

### 2-3-2. INSTALL NEW ZOOM MOTOR UNIT

- ① Install the Lens Flexible Board in new Zoom Motor Unit.
- ② Install new Zoom Motor Unit in the Lens Block.
- ③ Tighten two screws.  
\* Tightening torque = 0.7 kgf

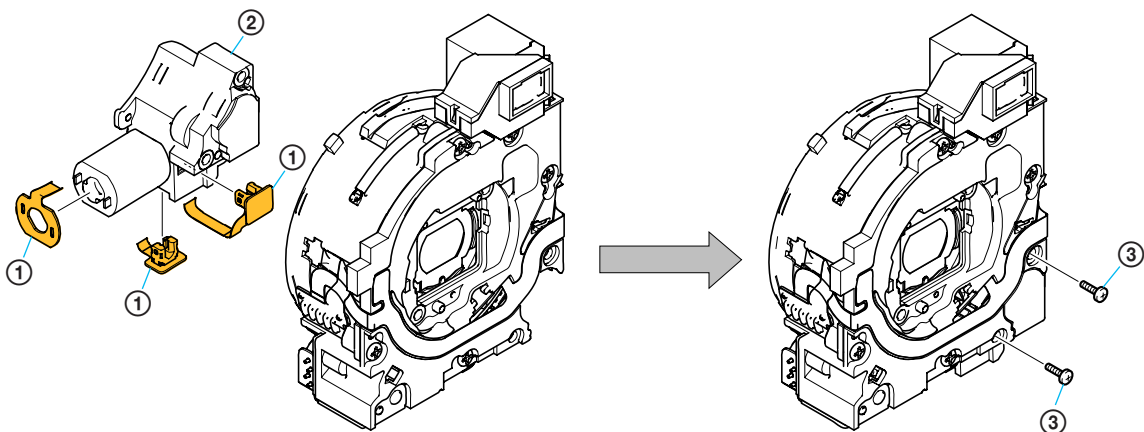

# HELP

Sheet attachment positions and procedures of processing the flexible boards/harnesses are shown.

---

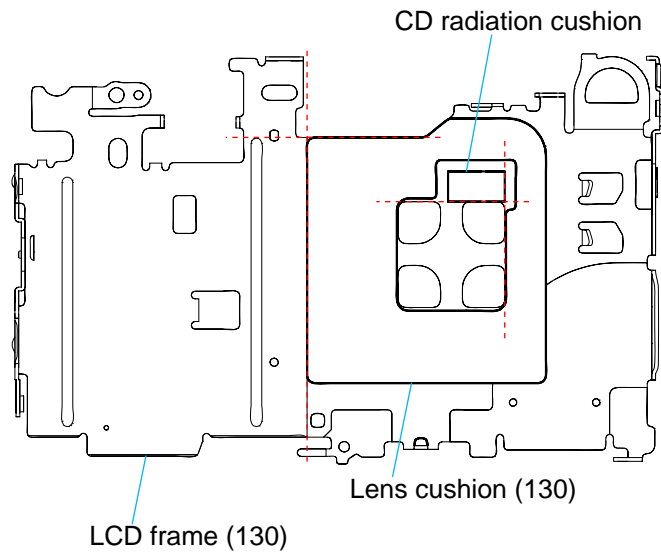

---

## 3. BLOCK DIAGRAMS

### Link

[OVERALL BLOCK DIAGRAM \(1/2\)](#)

[POWER BLOCK DIAGRAM](#)

[OVERALL BLOCK DIAGRAM \(2/2\)](#)



3-2. OVERALL BLOCK DIAGRAM (2/2) ( ) : Number in parenthesis ( ) indicates the division number of schematic diagram where the component is located.

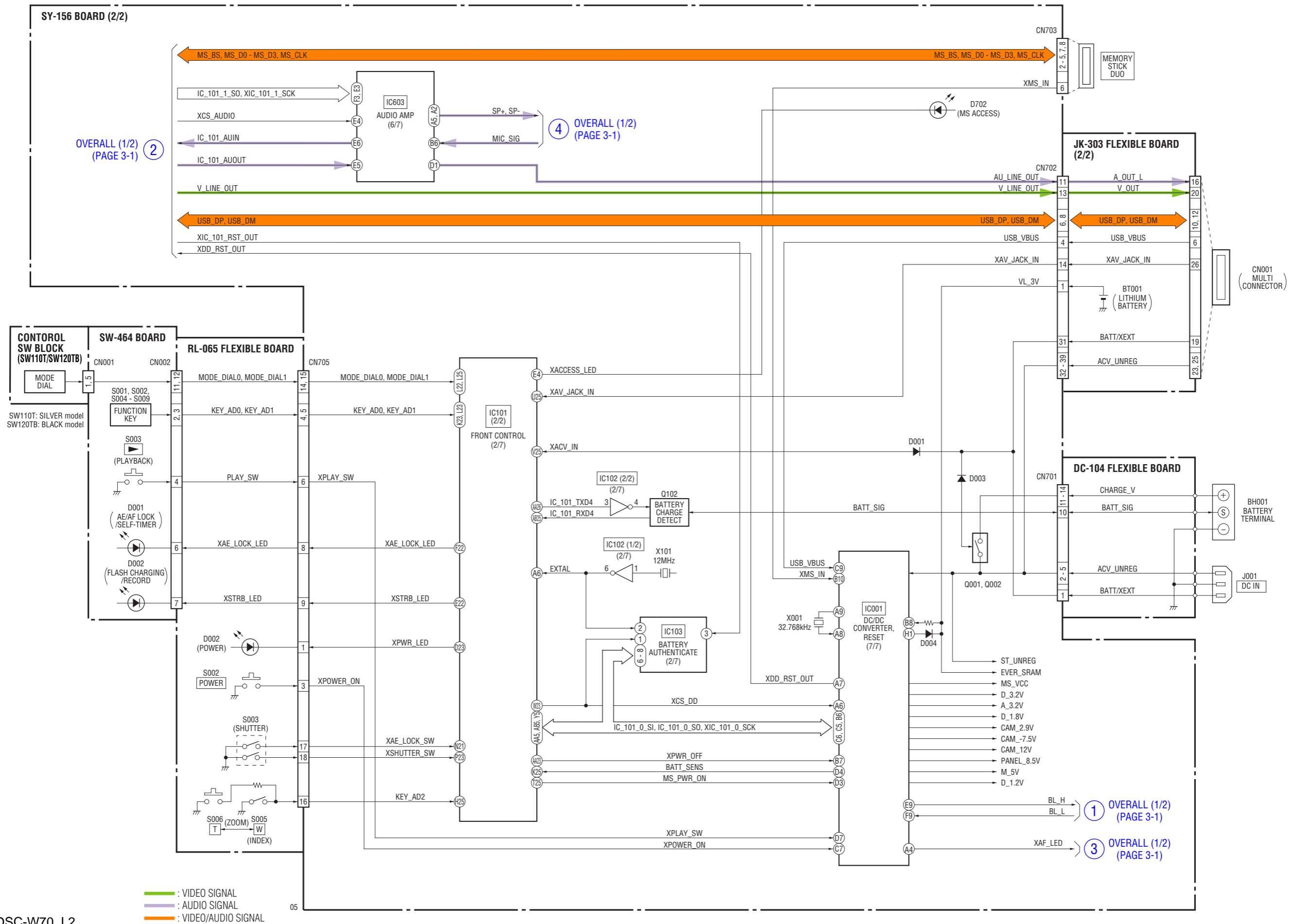

**3-3. POWER BLOCK DIAGRAM** ( ): Number in parenthesis ( ) indicates the division number of schematic diagram where the component is located.

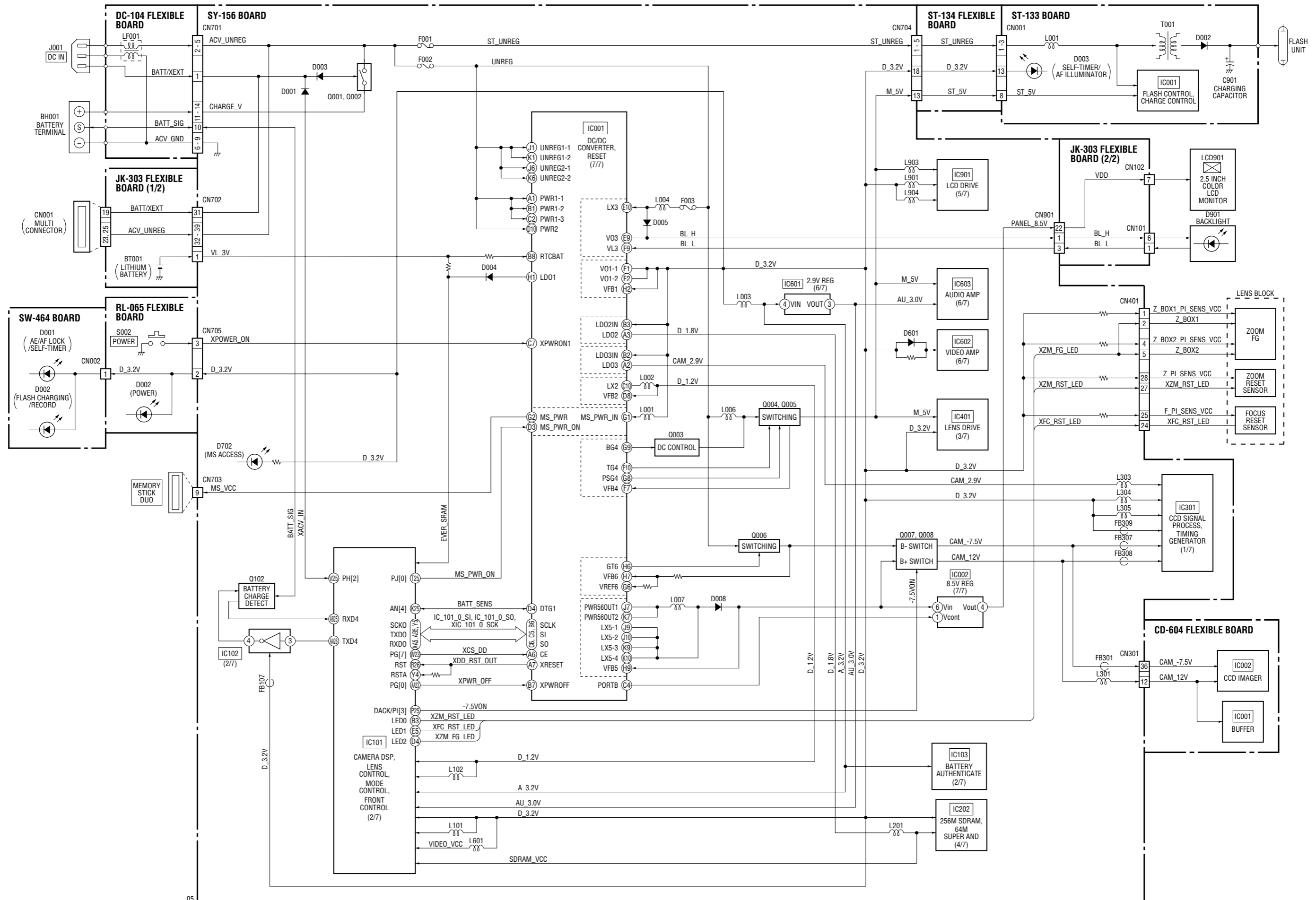

05

# 4. PRINTED WIRING BOARDS AND SCHEMATIC DIAGRAMS

## 4-1. FRAME SCHEMATIC DIAGRAM

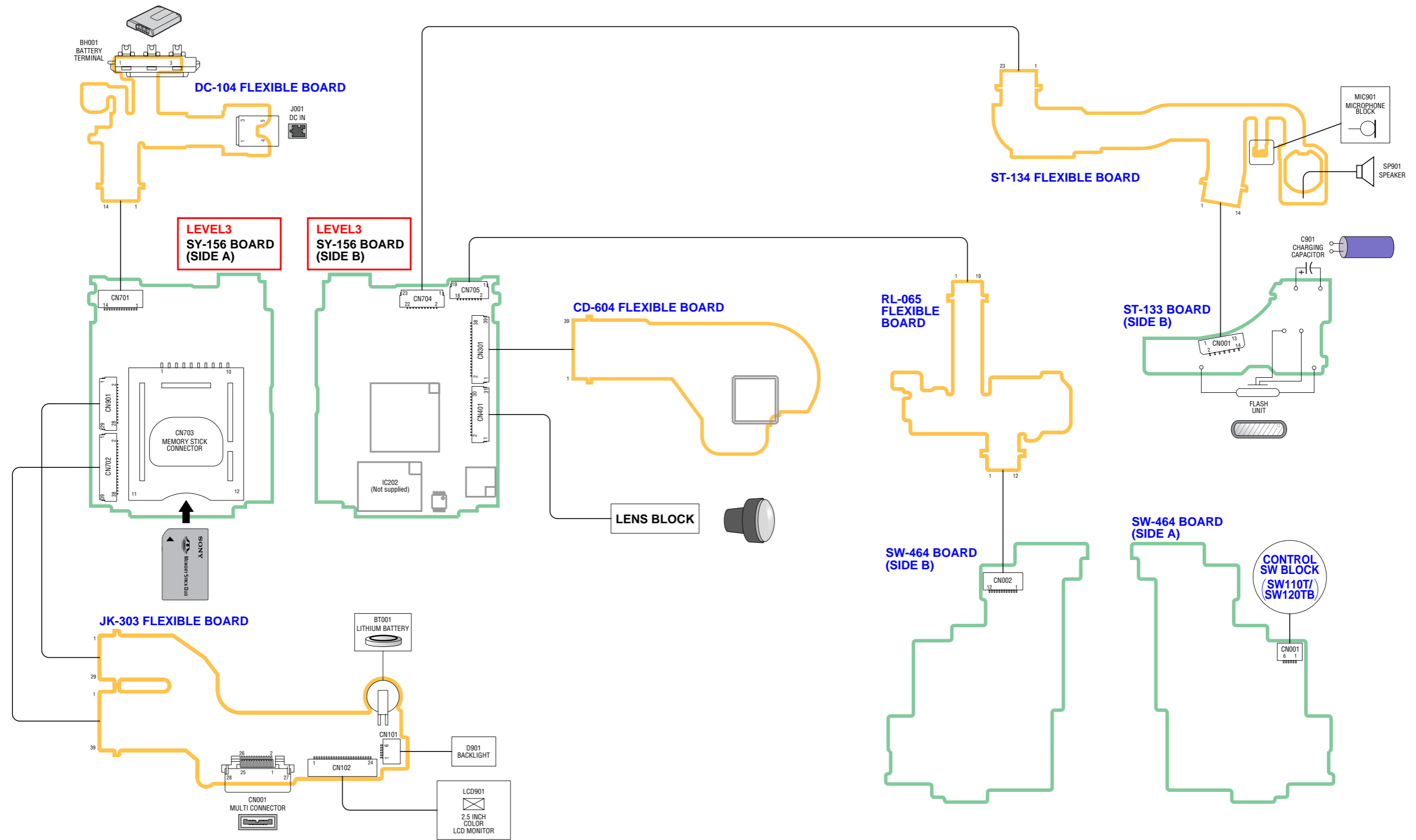

## 4-2. SCHEMATIC DIAGRAMS

### Link

<ul style="list-style-type: none"><li>• CD-604 FLEXIBLE BOARD (CCD IMAGER)</li></ul>	<ul style="list-style-type: none"><li>• RL-065 FLEXIBLE BOARD (CONTROL SWITCH)</li></ul>
<ul style="list-style-type: none"><li>• ST-133 BOARD (FLASH DRIVE)</li></ul>	<ul style="list-style-type: none"><li>• CONTROL SW BLOCK (SW110T/SW120TB)</li></ul>
<ul style="list-style-type: none"><li>• ST-134 FLEXIBLE BOARD</li></ul>	<ul style="list-style-type: none"><li>• JK-303 FLEXIBLE BOARD (MULTI/LCD CONNECTOR)</li></ul>
<ul style="list-style-type: none"><li>• SW-464 BOARD (CONTROL SWITCH)</li></ul>	<ul style="list-style-type: none"><li>• DC-104 FLEXIBLE BOARD (BATTERY IN, DC IN)</li></ul>

- COMMON NOTE FOR SCHEMATIC DIAGRAMS

## 4-2. SCHEMATIC DIAGRAMS

### 4-2. SCHEMATIC DIAGRAMS

**THIS NOTE IS COMMON FOR SCHEMATIC DIAGRAMS**

**(In addition to this, the necessary note is printed in each block)**

**(For schematic diagrams)**

- All capacitors are in  $\mu\text{F}$  unless otherwise noted.  $\text{pF} : \mu\text{F} : 50\text{V}$  or less are not indicated except for electrolytics and tantalums.
- Chip resistors are  $1/10\text{W}$  unless otherwise noted.  $\text{k}\Omega=1000\ \Omega$ ,  $\text{M}\Omega=1000\ \text{k}\Omega$ .
- Caution when replacing chip parts.  
New parts must be attached after removal of chip.  
Be careful not to heat the minus side of tantalum capacitor, Because it is damaged by the heat.
- Some chip part will be indicated as follows.

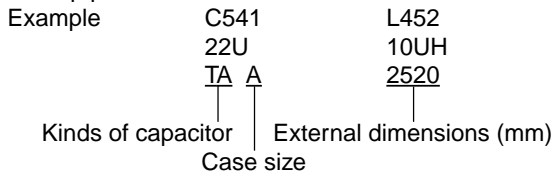

- Constants of resistors, capacitors, ICs and etc with XX indicate that they are not used.  
In such cases, the unused circuits may be indicated.
- Parts with ★ differ according to the model/destination. Refer to the mount table for each function.
- All variable and adjustable resistors have characteristic curve B, unless otherwise noted.
- Signal name  
XEDIT →  $\overline{\text{EDIT}}$       PB/XREC →  $\overline{\text{PB/REC}}$
- : non flammable resistor
- : fusible resistor
- : panel designation
- : B+ Line
- : B- Line
- : IN/OUT direction of (+,-) B LINE.
- : adjustment for repair.
- : not use circuit

**(Measuring conditions voltage and waveform)**

- Voltages and waveforms are measured between the measurement points and ground when camera shoots color bar chart of pattern box. They are reference values and reference waveforms.  
(VOM of DC  $10\ \text{M}\Omega$  input impedance is used)
- Voltage values change depending upon input impedance of VOM used.)

**Precautions for Replacement of Imager**

- If the imager has been replaced, carry out all the adjustments for the camera section.
- As the imager may be damaged by static electricity from its structure, handle it carefully like for the MOS IC.  
In addition, ensure that the receiver is not covered with dusts nor exposed to strong light.

**1. Connection**

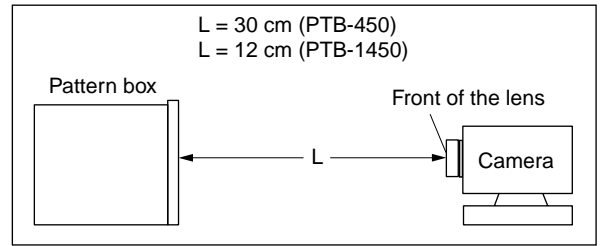
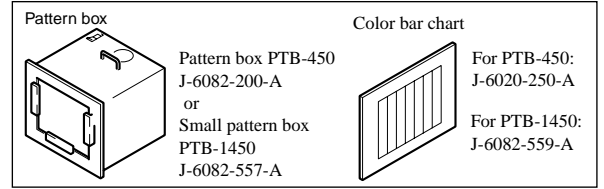

2. Adjust the distance so that the output waveform of Fig. a and the Fig. b can be obtain.

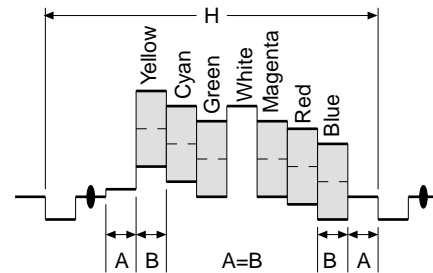

Fig. a (Video output terminal output waveform)

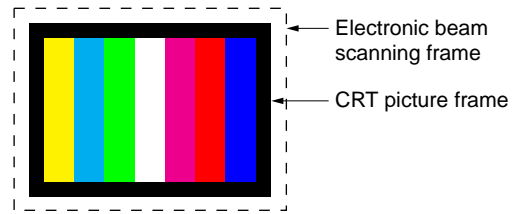

Fig.b (Picture on monitor TV)

When indicating parts by reference number, please include the board name.

The components identified by mark  $\triangle$  or dotted line with mark  $\triangle$  are critical for safety.  
Replace only with part number specified.

Les composants identifiés par une marque  $\triangle$  sont critiques pour la sécurité.  
Ne les remplacer que par une pièce portant le numéro spécifié.

A  
B  
C  
D  
E  
F  
G  
H  
I

# CD-604 FLEXIBLE BOARD

CCD IMAGER  
XX MARK:NO MOUNT

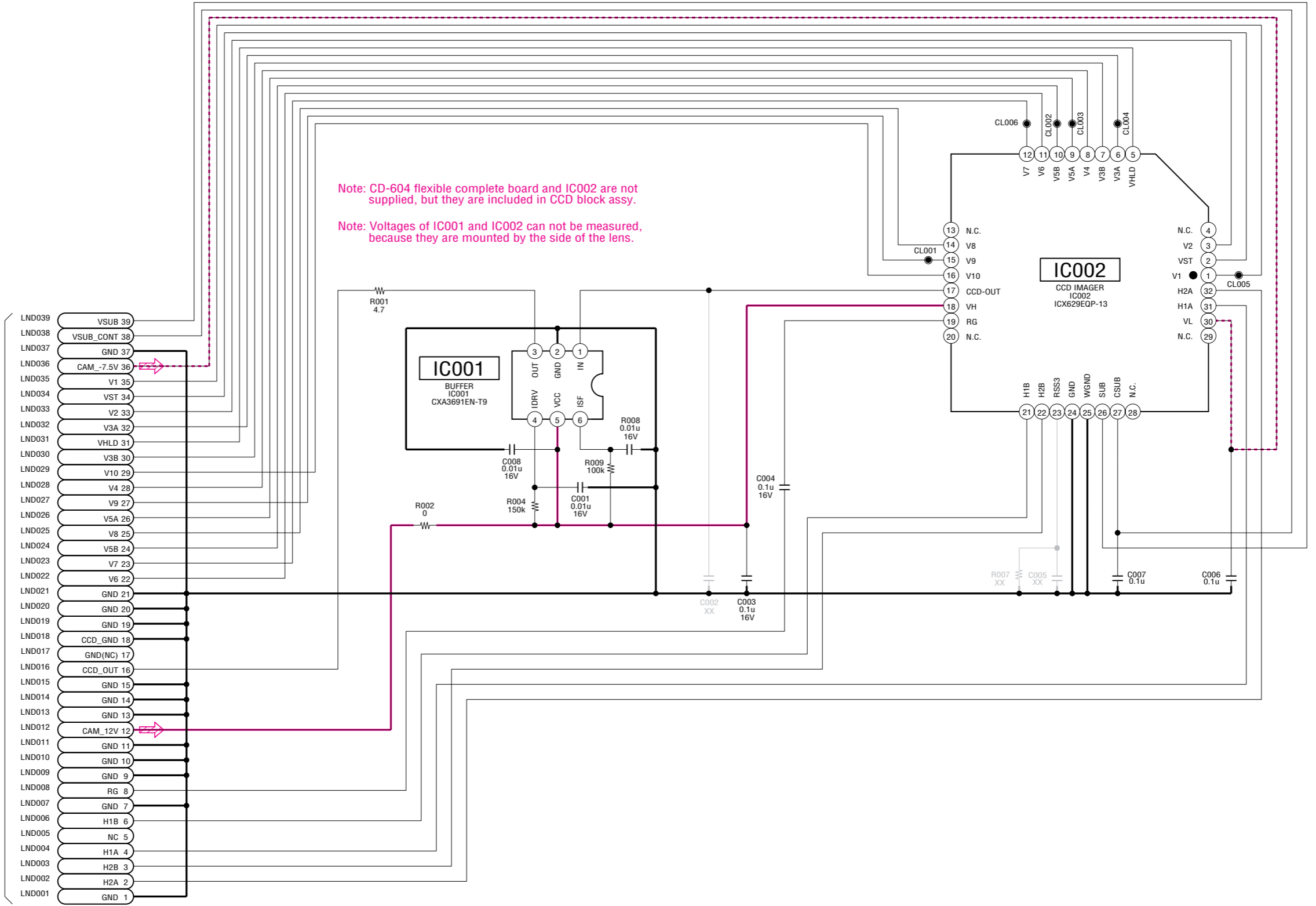

SY-156  
(1/7)  
CN301  
(Page 4-6  
of Level 3)

Schematic diagrams of the SY-156 board are not shown.  
Pages from 4-6 to 4-12 are not shown.

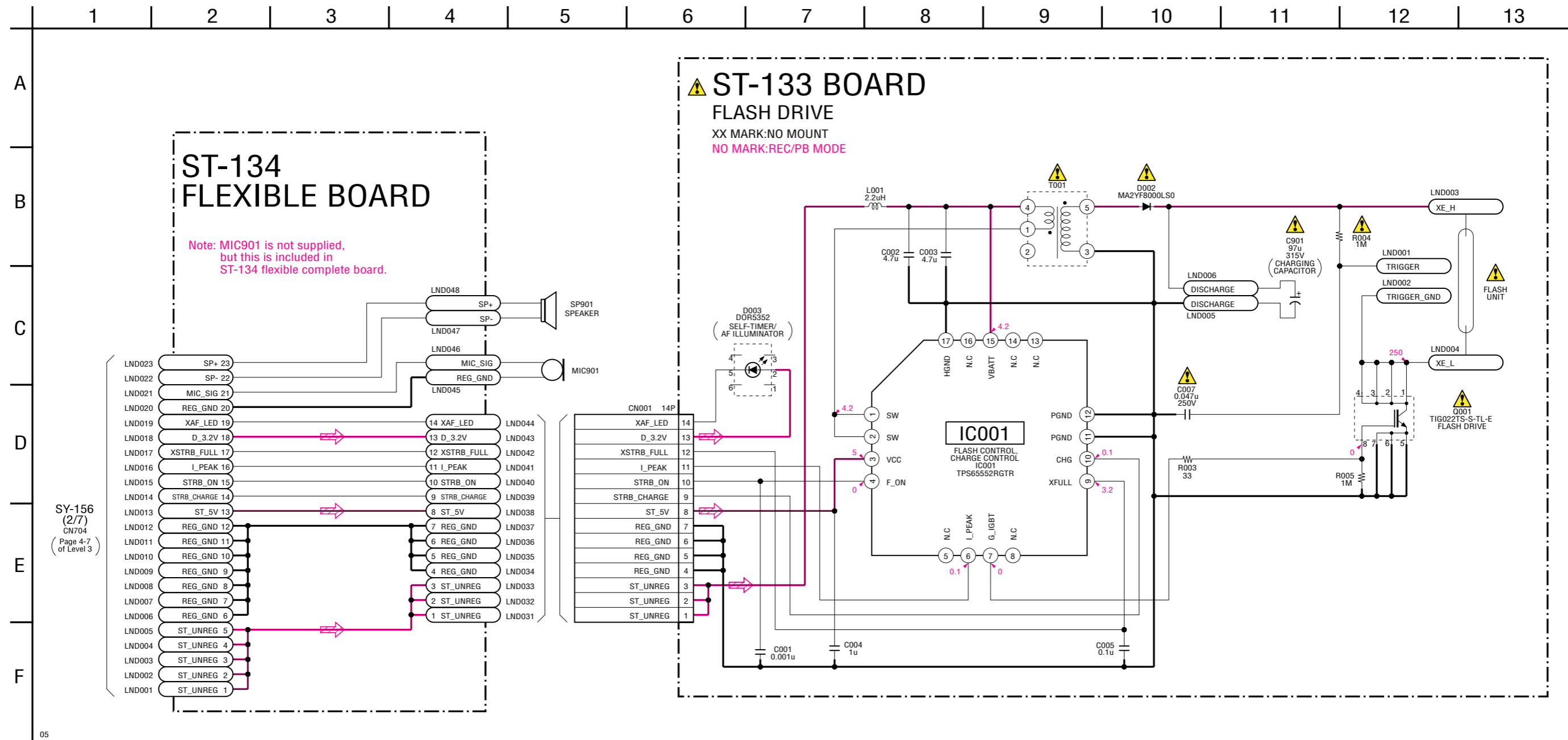

A  
B  
C  
D  
E  
F  
G  
H  
I

### RL-065 FLEXIBLE BOARD CONTROL SWITCH

XX MARK:NO MOUNT  
 Note: RL-065 flexible complete board and S003 (shutter) are not supplied, but they are included in cabinet (upper) block assy.

SY-156 (2/7)  
 CN705  
 (Page 4-7 of Level 3)

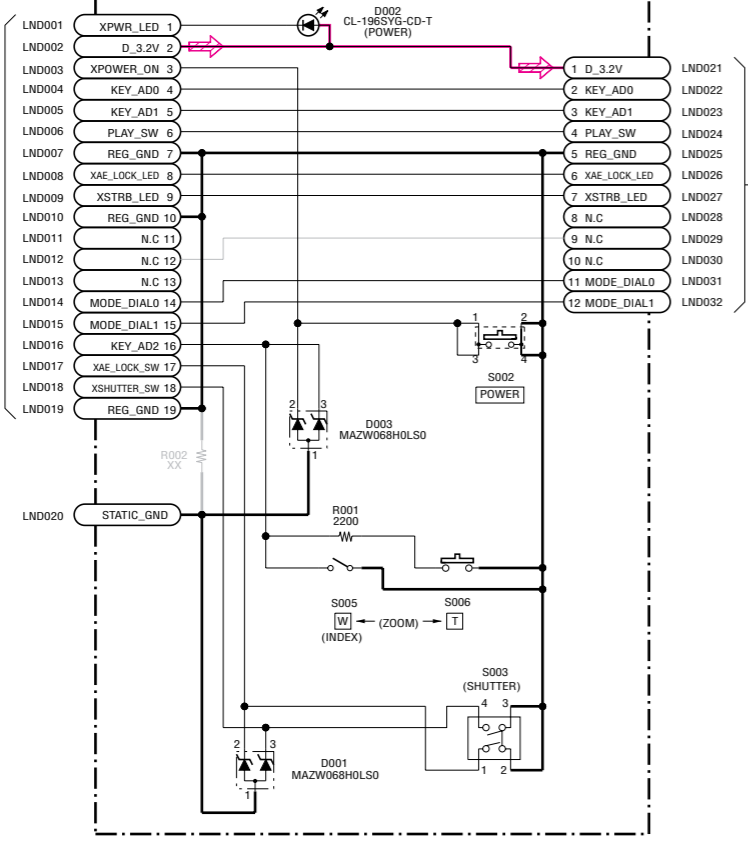

### SW-464 BOARD CONTROL SWITCH

XX MARK:NO MOUNT

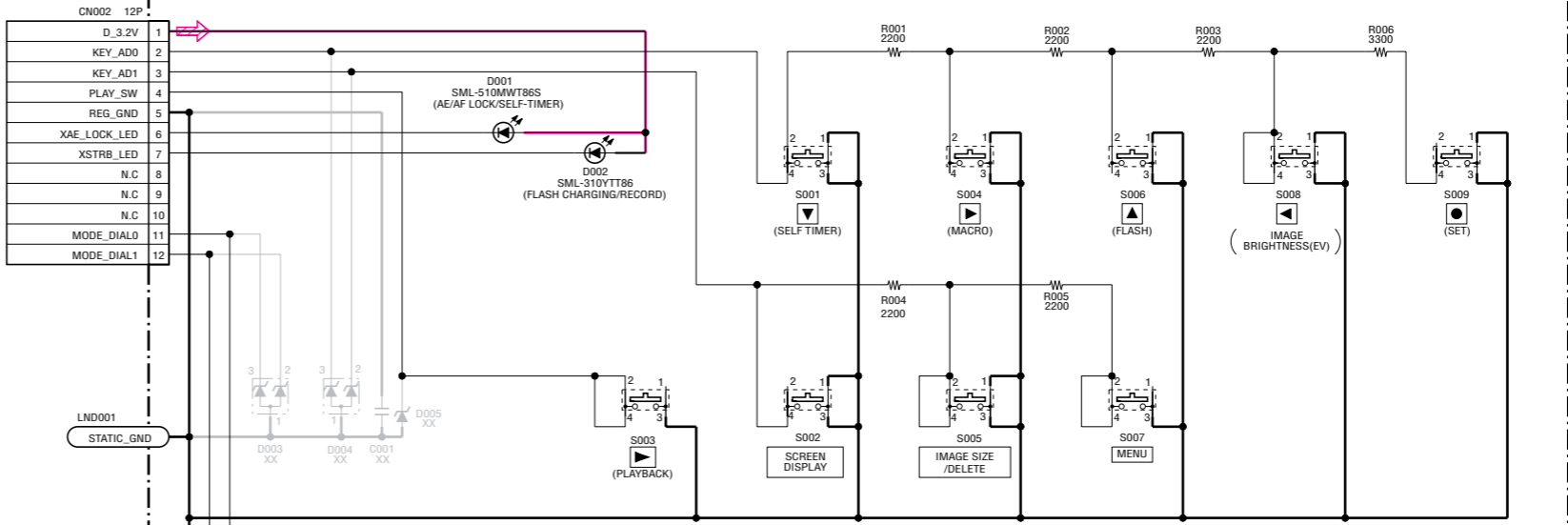

### CONTROL SW BLOCK (SW110T/SW120TB)

(CONTROL SW BLOCK (SW110T/SW120TB) is replaced as block, so that PRINTED WIRING BOARD is omitted.)  
 SW110T: SILVER model  
 SW120TB: BLACK model

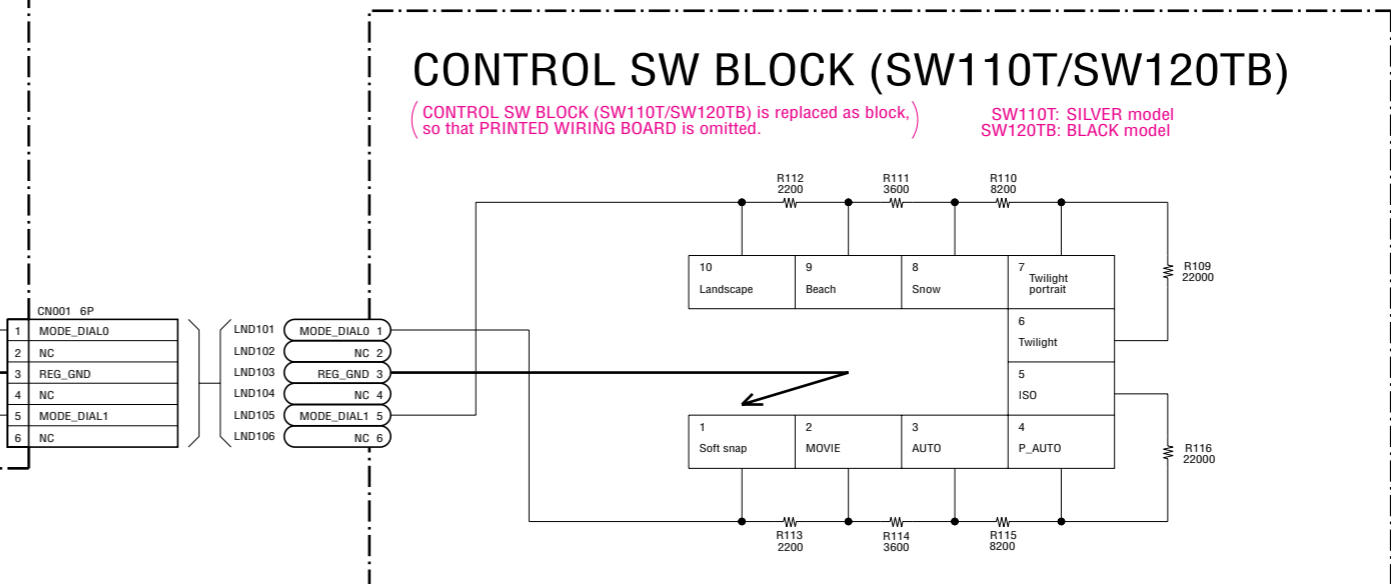

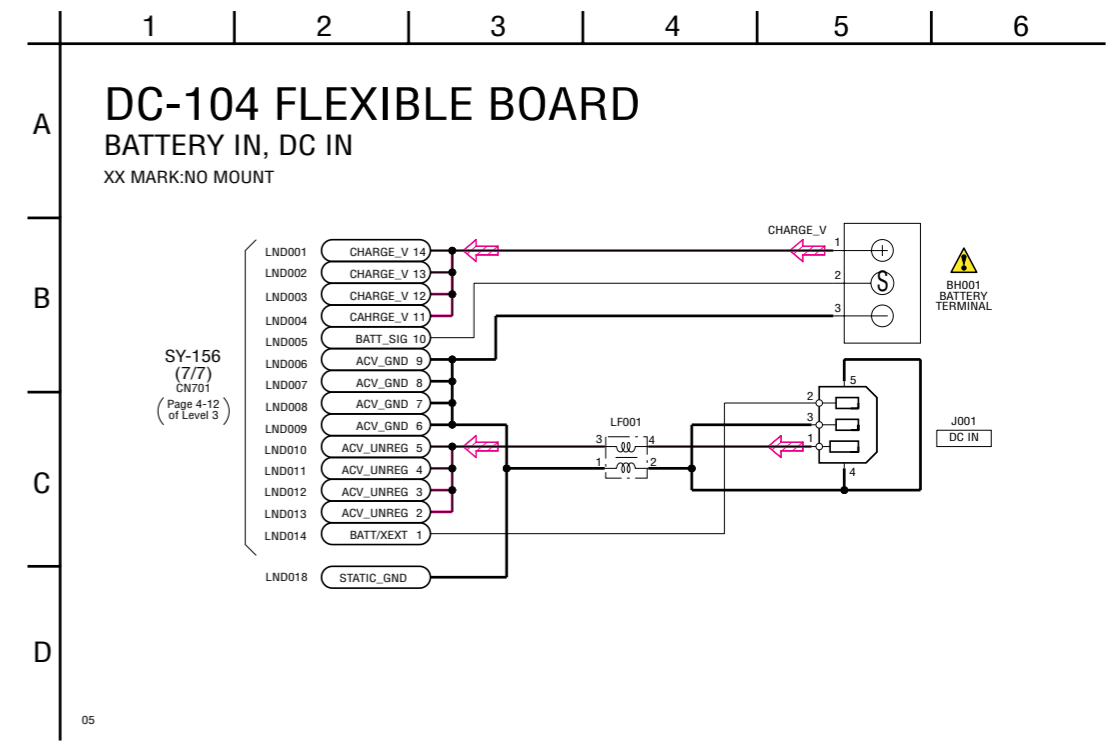
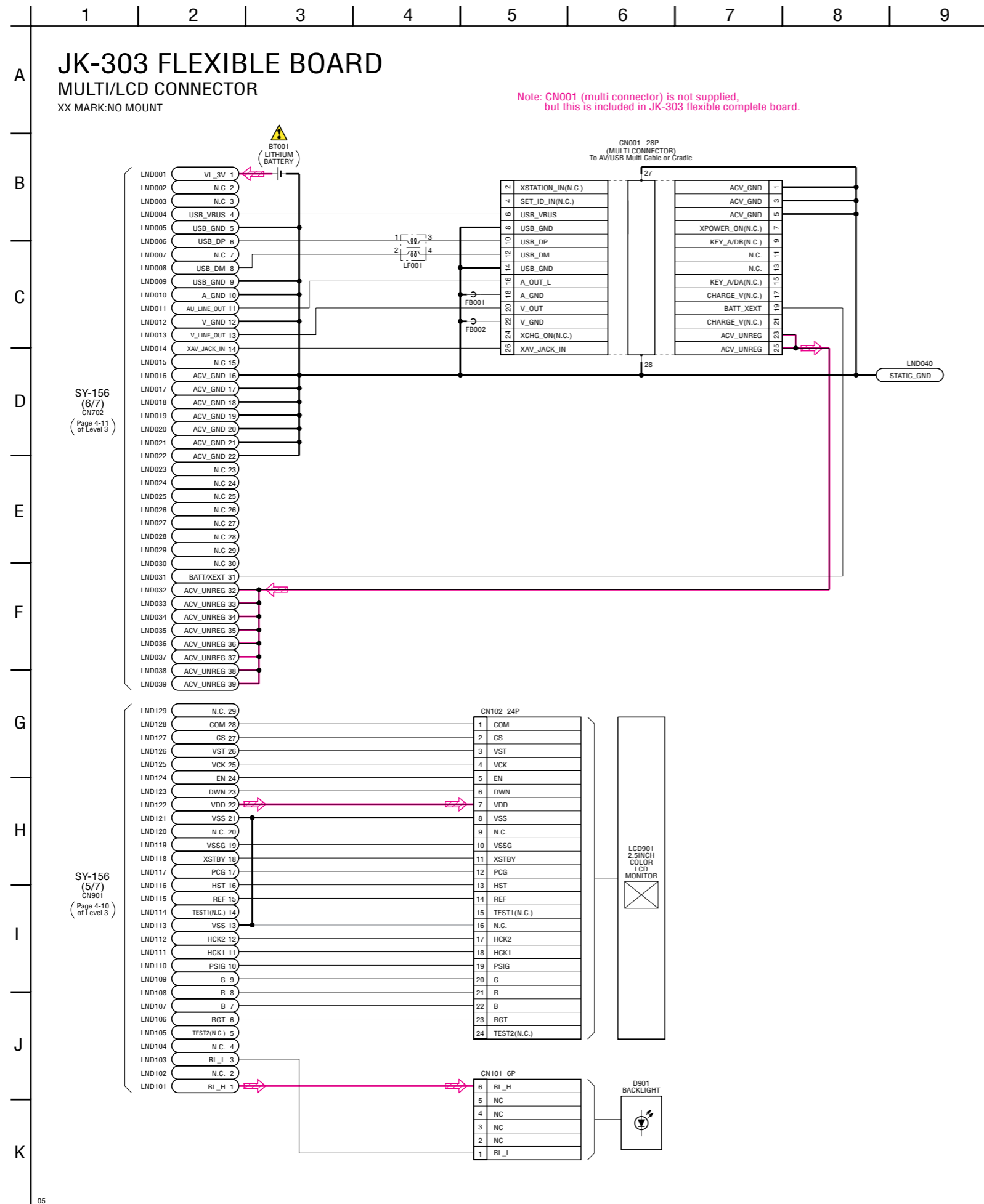

## 4-3. PRINTED WIRING BOARDS

### Link

[• CD-604 FLEXIBLE BOARD](#)

[• RL-065 FLEXIBLE BOARD](#)

[• ST-133 BOARD](#)

[• JK-303 FLEXIBLE BOARD](#)

[• ST-134 FLEXIBLE BOARD](#)

[• DC-104 FLEXIBLE BOARD](#)

[• SW-464 BOARD](#)

[• COMMON NOTE FOR PRINTED WIRING BOARDS](#)

[• MOUNTED PARTS LOCATION](#)

# 4-3. PRINTED WIRING BOARDS

## 4-3. PRINTED WIRING BOARDS

**THIS NOTE IS COMMON FOR PRINTED WIRING BOARDS**

- : Uses unleaded solder.
- : Circuit board
- : Flexible board
- : Pattern from the side which enables seeing.
- : pattern of the rear side  
(The other layers' patterns are not indicated)
- Through hole is omitted.
- There are a few cases that the part printed on diagram isn't mounted in this model.
- : panel designation

- Chip parts.

Transistor

Diode

Labels for Transistor diagrams: C, B, E, 6 5 4, 4 5 6, 5 4, 4 5, 1 2 3, 3 2 1, 1 2 3, 3 2 1, 1 2 3, 3 2 1, 1 2, 2 1, 3 2, 5 4 3, 3 4 5, 4 1

Labels for Diode diagrams: 3, 3, 3, 1 2 3, 2 1, 2 1, 2 1, 6 5 4, 4 3, 3 4, 6 5 4, 4 5 6, 1 2, 1 2, 2 1, 1 2 3, 3 2 1, 3 2, 4 1

CD-604 (2 layers)

 : Uses unleaded solder.

### CD-604 FLEXIBLE BOARD

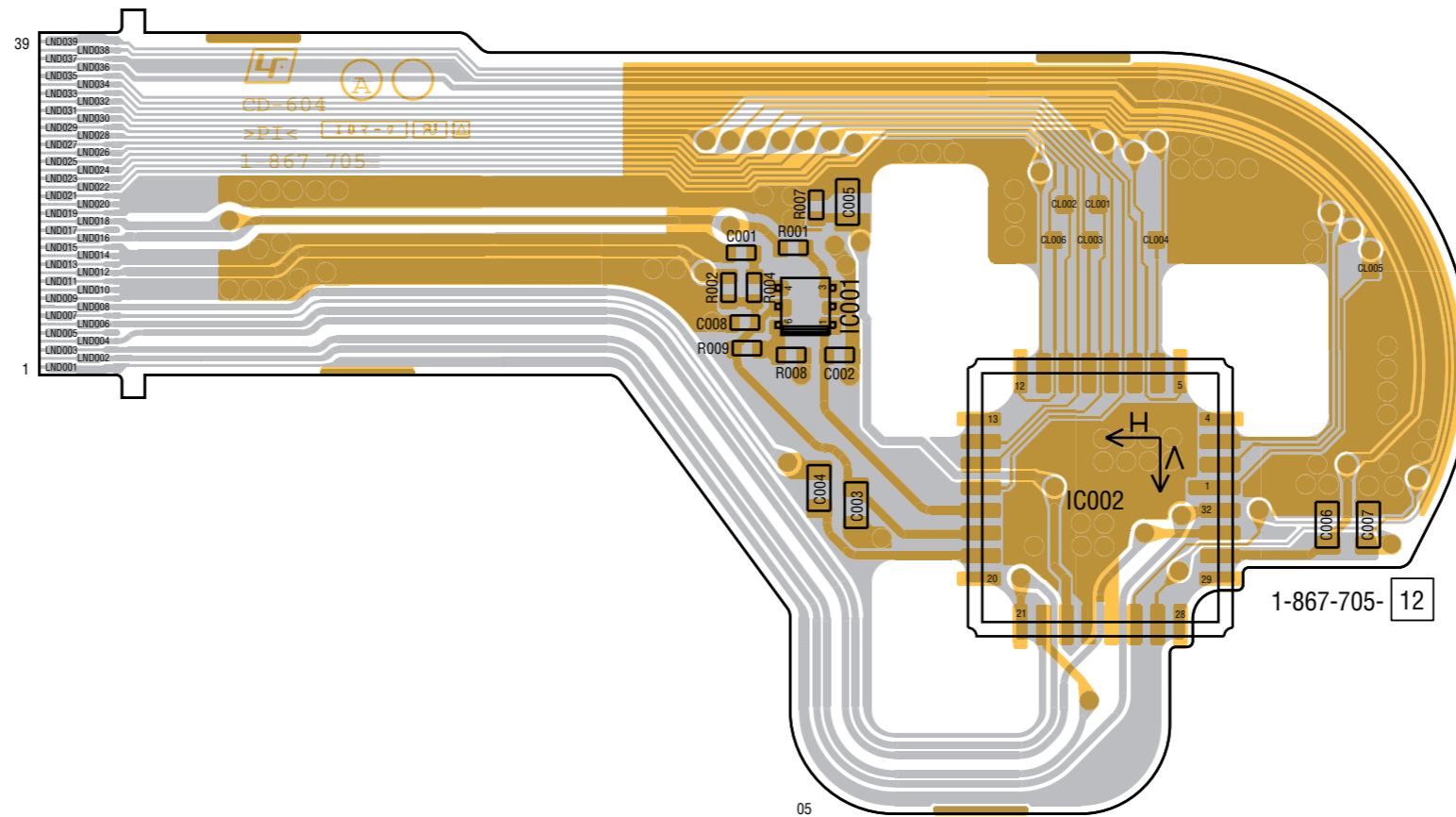

Note: CD-604 flexible complete board and IC002 are not supplied, but they are included in CCD block assy.

Printed wiring boards of the SY-156 board are not shown.  
Page 4-20 is not shown.

 : Uses unleaded solder.

### ST-133 BOARD (SIDE A)



D003  
SELF-TIMER/  
AF ILLUMINATOR

### ST-133 BOARD (SIDE B)

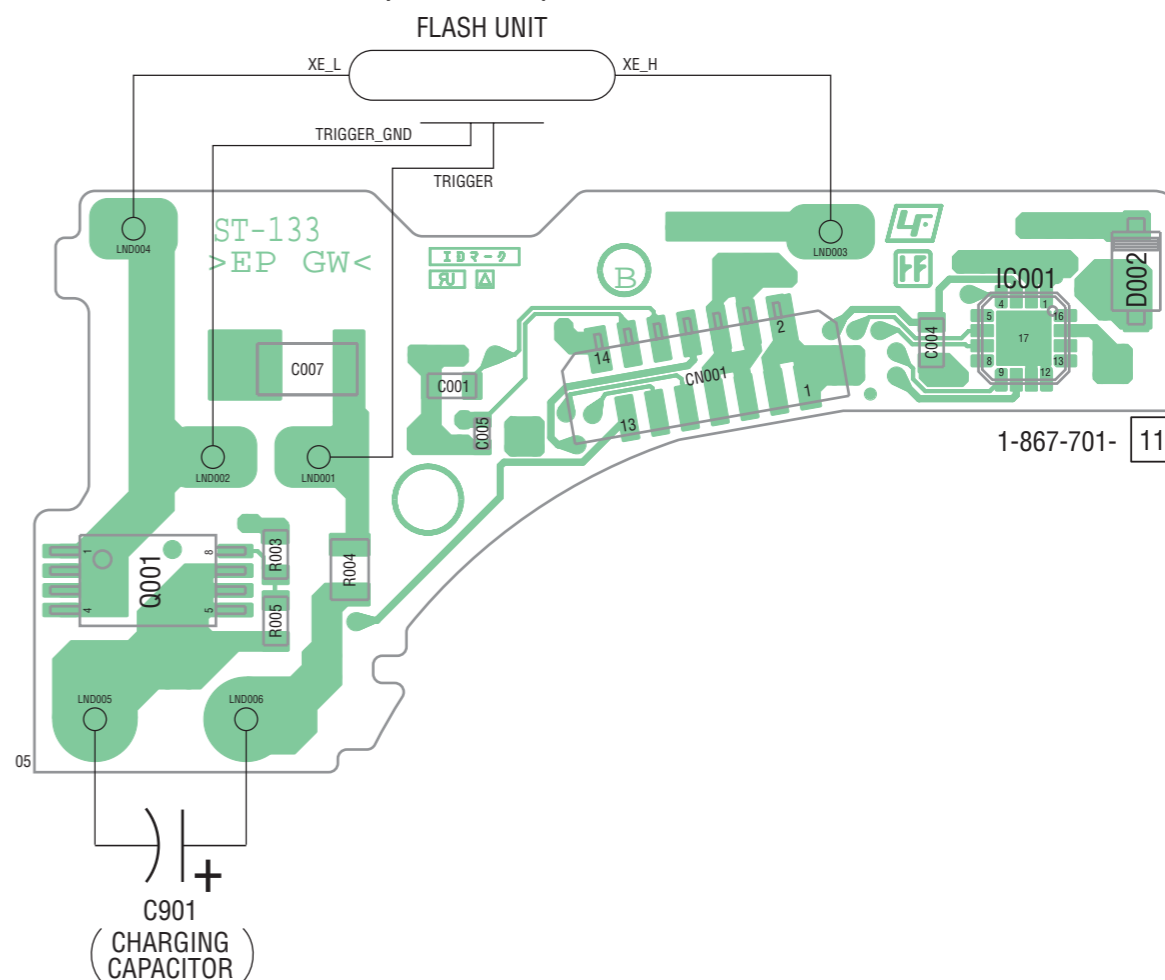

### ST-134 FLEXIBLE BOARD

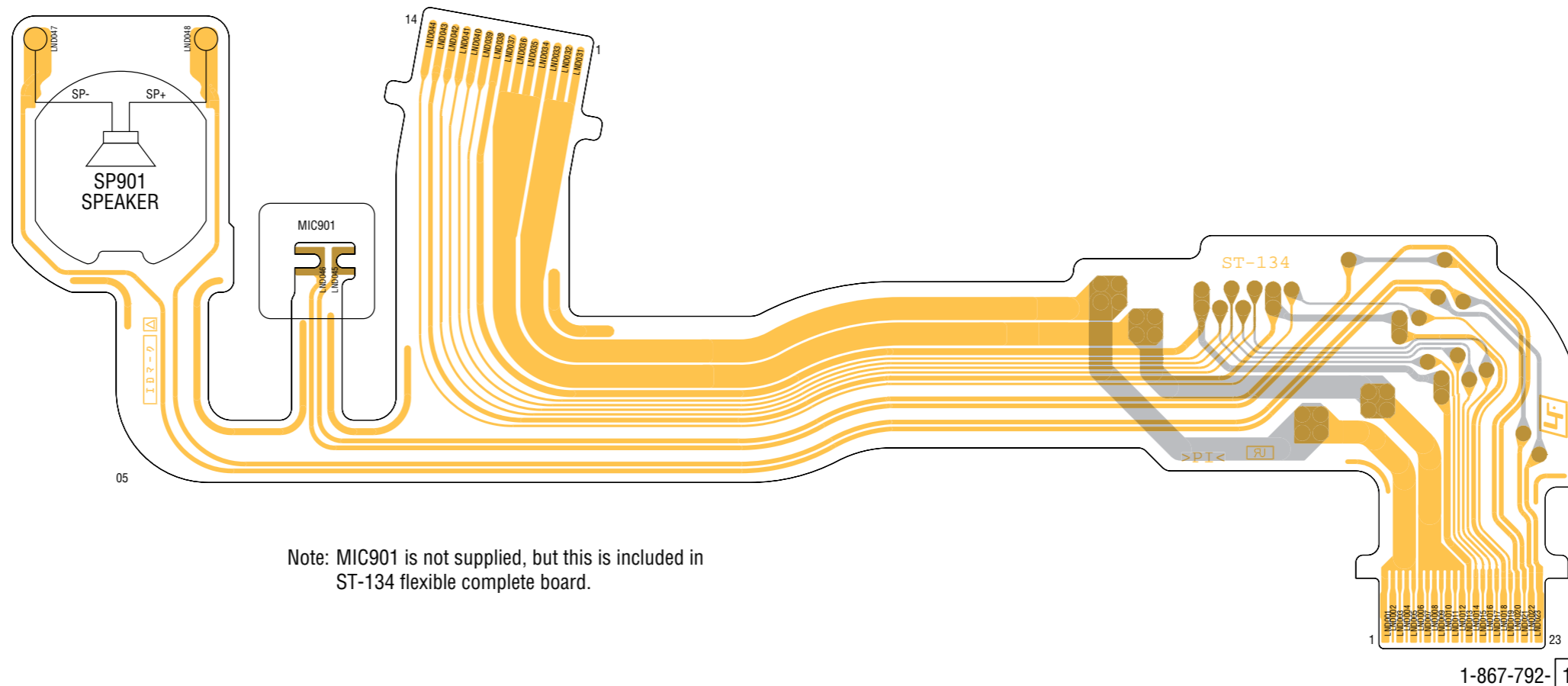

Note: MIC901 is not supplied, but this is included in ST-134 flexible complete board.

 : Uses unleaded solder.

### SW-464 BOARD (SIDE A)

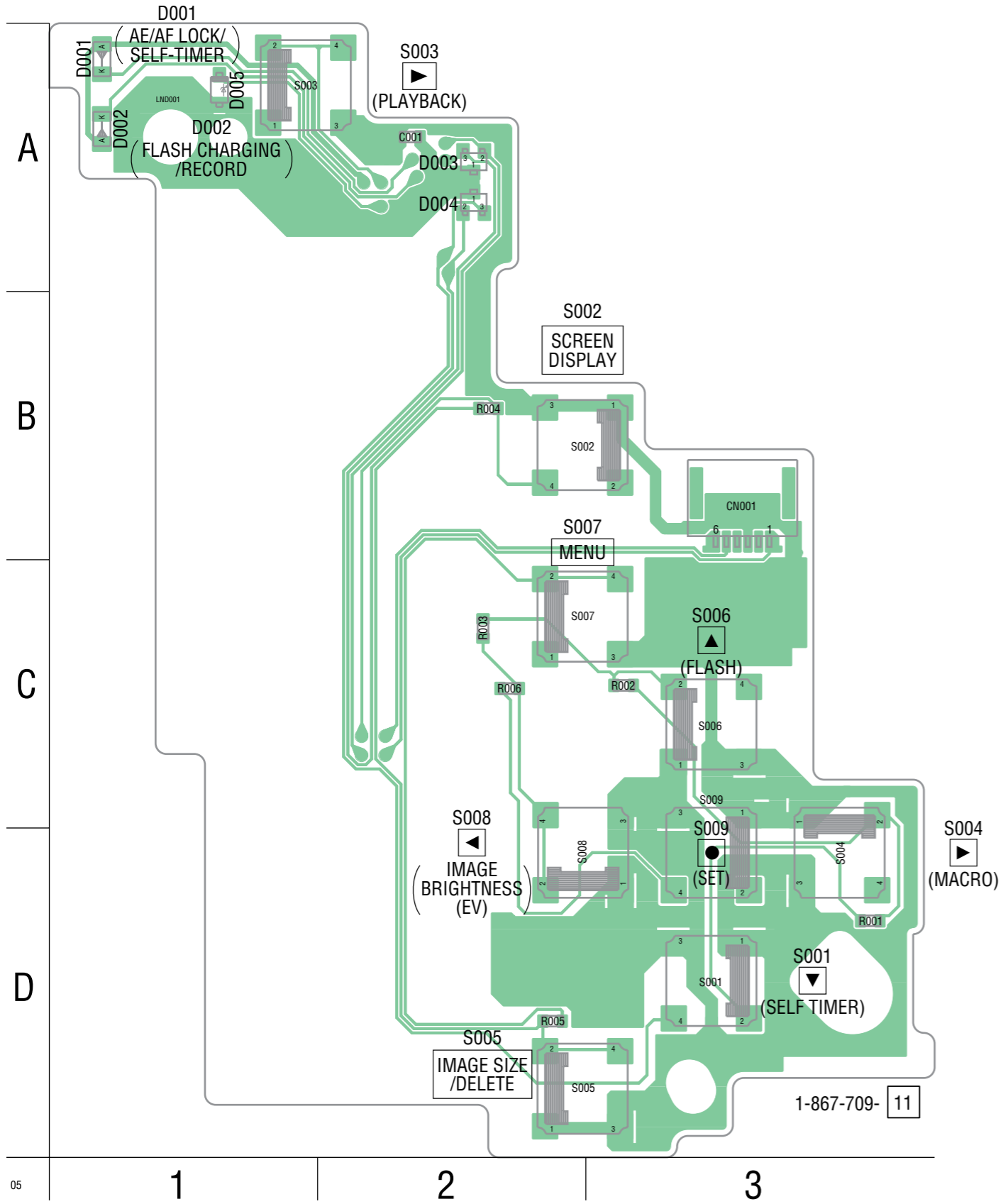

### SW-464 BOARD (SIDE B)

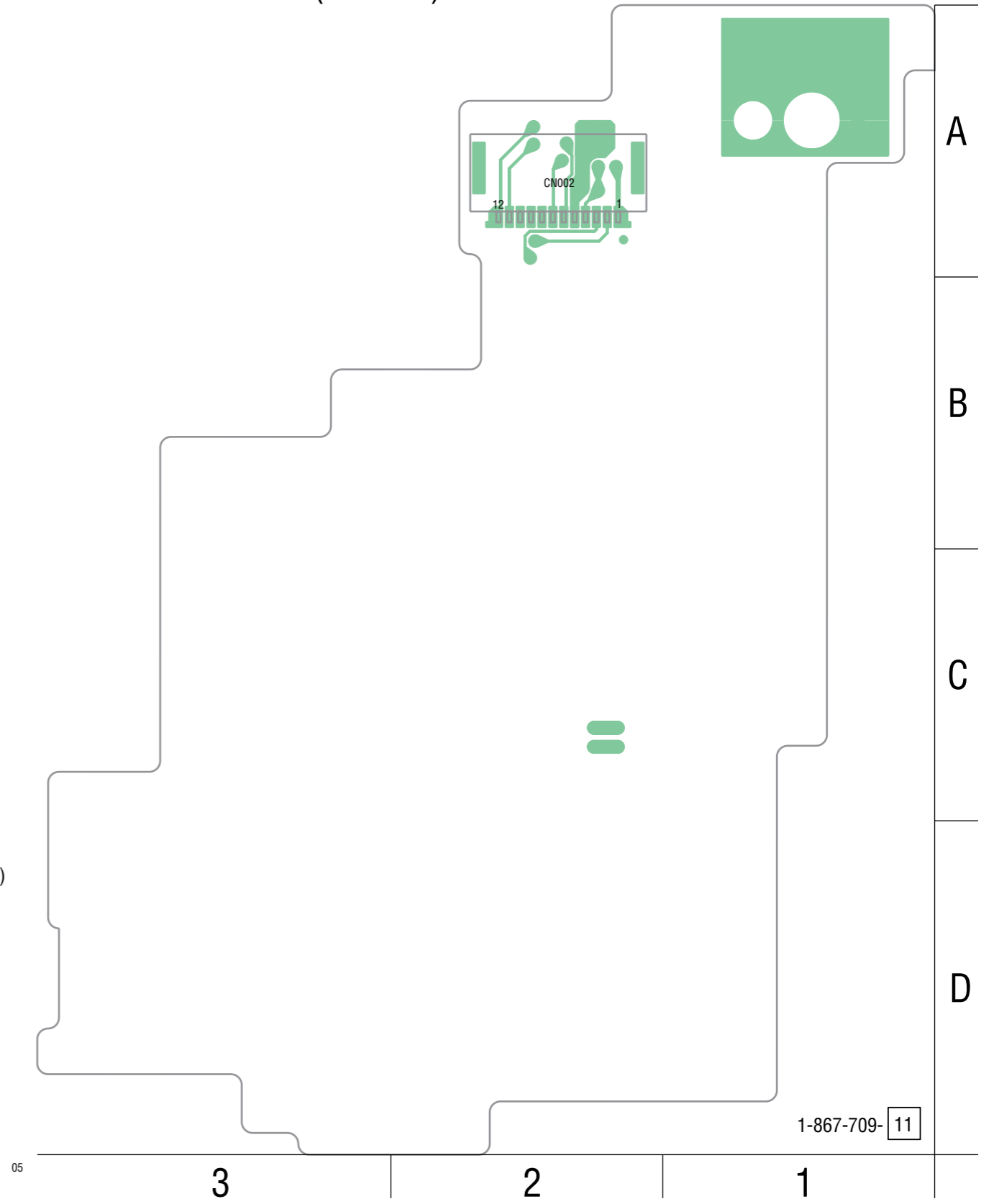

05

1

2

3

05

3

2

1

 : Uses unleaded solder.

### RL-065 FLEXIBLE BOARD

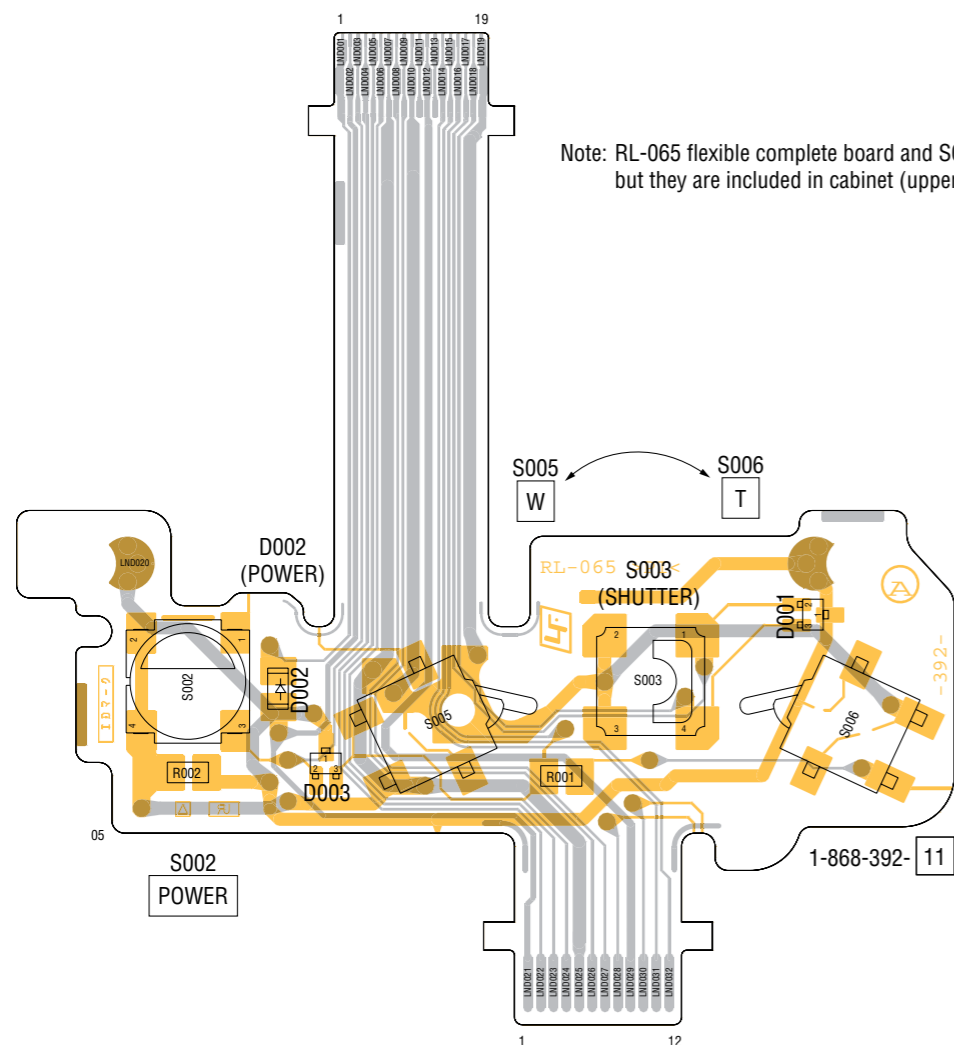

Note: RL-065 flexible complete board and S003 (shutter) are not supplied, but they are included in cabinet (upper) block assy.

### DC-104 FLEXIBLE BOARD

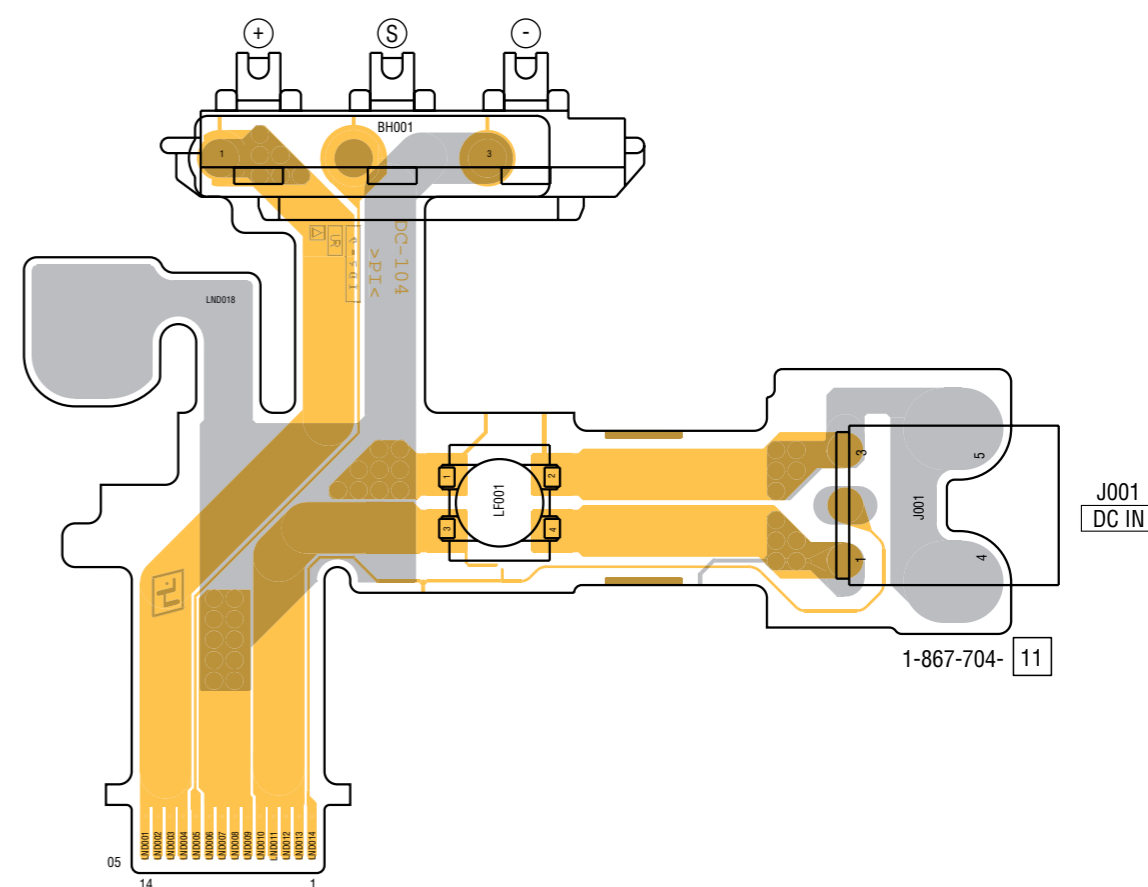

### JK-303 FLEXIBLE BOARD

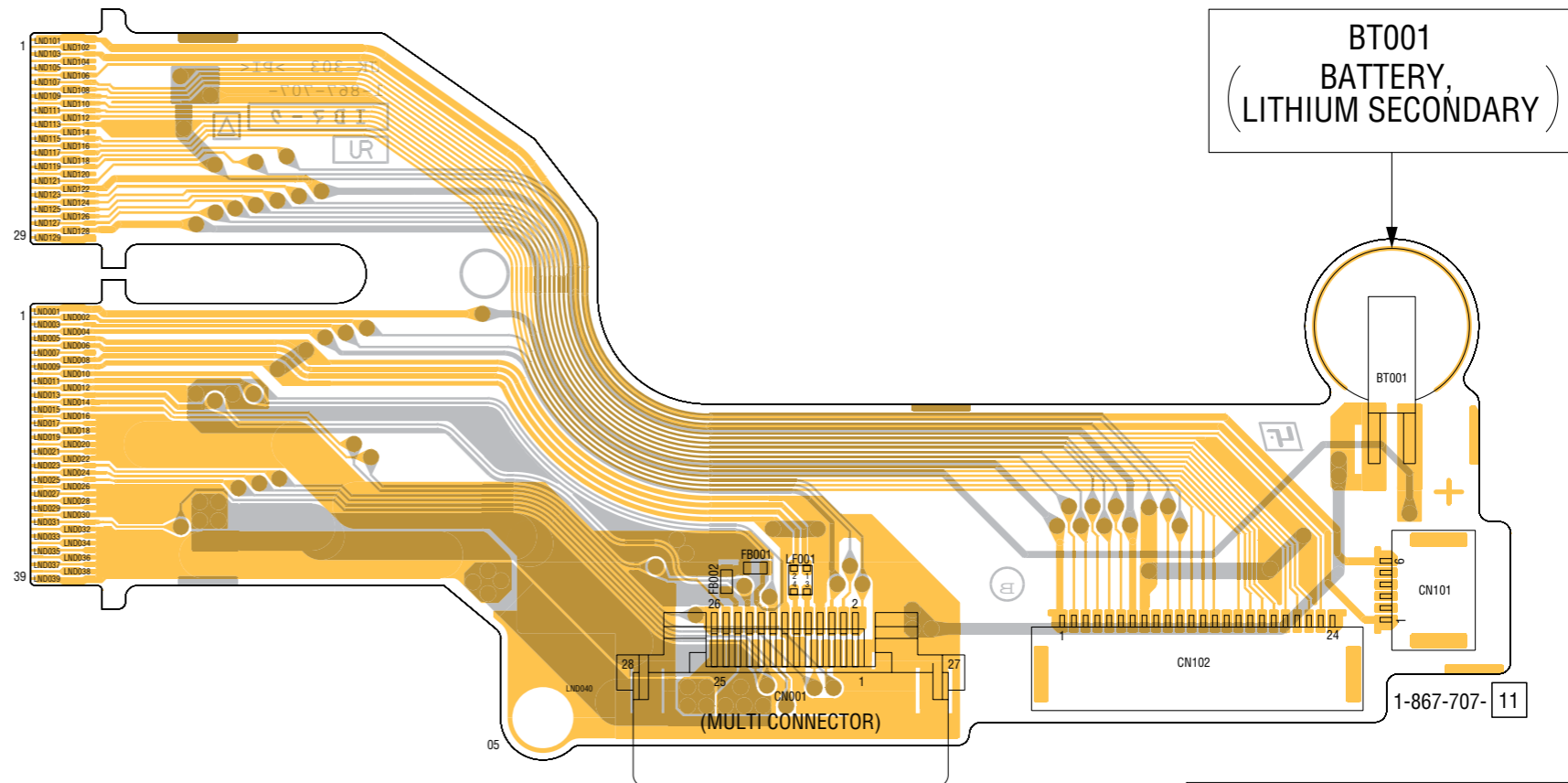

Note: CN001 (multi connector) is not supplied, but this is included in JK-303 flexible complete board.

**CAUTION**  
 Danger of explosion if battery is incorrectly replaced.  
 Replace only with the same or equivalent type.

Mounted parts location of the SY-156 board are not shown.  
Page 4-25 is not shown.

## 4-3. PRINTED WIRING BOARDS

### 4-4. MOUNTED PARTS LOCATION

no mark : side A  
\* mark : side B

#### SW-464 BOARD

CN001	B-3
* CN002	A-2
D001	A-1
D002	A-1
R001	D-3
R002	C-3
R003	C-2
R004	B-2
R005	D-2
R006	C-2
S001	D-3
S002	B-2
S003	A-1
S004	D-3
S005	D-2
S006	C-3
S007	C-2
S008	D-2
S009	D-3

## 5. REPAIR PARTS LIST

NOTE: Characters **A** to **Z** of the electrical parts list indicate location of exploded views in which the desired part is shown.

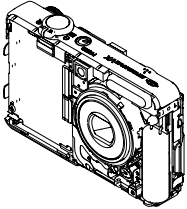
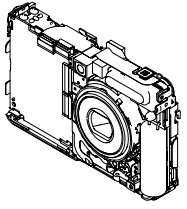
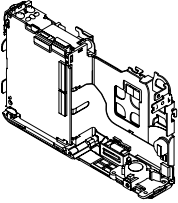
Link	EXPLODED VIEWS		
 <b>A</b>	 <b>B</b>	 <b>C</b>	
<b>CABINET BLOCK</b>	<b>LCD BLOCK</b>	<b>LENS BLOCK</b>	
 <b>D</b>			
<b>BT HOLDER BLOCK</b>			

Link	ELECTRICAL PARTS LIST			ACCESSORIES
<a href="#">CD-604 FLEXIBLE BOARD</a> <b>C</b>	<a href="#">RL-065 FLEXIBLE BOARD</a> <b>B</b>	<a href="#">ST-134 FLEXIBLE BOARD</a> <b>C</b>		
<a href="#">DC-104 FLEXIBLE BOARD</a> <b>D</b>	<a href="#">ST-133 BOARD</a> <b>C</b>	<a href="#">SW-464 BOARD</a> <b>B</b>		
<a href="#">JK-303 FLEXIBLE BOARD</a> <b>D</b>				

## 5. REPAIR PARTS LIST

### 5. REPAIR PARTS LIST

**NOTE:**

- -XX, -X mean standardized parts, so they may have some differences from the original one.
- Items marked “\*” are not stocked since they are seldom required for routine service. Some delay should be anticipated when ordering these items.
- The mechanical parts with no reference number in the exploded views are not supplied.
- Due to standardization, replacements in the parts list may be different from the parts specified in the diagrams or the components used on the set.
- **CAPACITORS:**  
uF:  $\mu$ F
- **COILS**  
uH:  $\mu$ H
- **RESISTORS**  
All resistors are in ohms.  
METAL: metal-film resistor  
METAL OXIDE: Metal Oxide-film resistor  
F: nonflammable
- **SEMICONDUCTORS**  
In each case, u:  $\mu$ , for example:  
uA...:  $\mu$ A... , uPA... ,  $\mu$ PA... ,  
uPB... ,  $\mu$ PB... ,  $\mu$ PC... ,  $\mu$ PC... ,  
uPD... ,  $\mu$ PD...
- **Abbreviation**  
AR : Argentine model  
AUS : Australian model  
BR : Brazilian model  
CH : Chinese model  
CND : Canadian model  
EE : East European model  
HK : Hong Kong model  
J : Japanese model  
JE : Tourist model  
KR : Korea model  
NE : North European model  
TW : Taiwan model

When indicating parts by reference number, please include the board name.

The components identified by mark  $\triangle$  or dotted line with mark  $\triangle$  are critical for safety. Replace only with part number specified.

Les composants identifiés par une marque  $\triangle$  sont critiques pour la sécurité. Ne les remplacer que par une pièce portant le numéro spécifié.

- **Color Indication of Appearance Parts**  
Example:  
(SILVER): Cabinet's Color  
(Silver): Parts Color

• **Language that can be selected about SY-156 board**

	Area	Japanese	English	French	German	Spanish	Italian	Portugal	Simplified Chinese	Traditional Chinese	Arabic	Dutch	Russian	Swedish	Korean	Norwegian	Danish	Finnish	Polish	Hungarian	Czech	Persian	Thai	
GP1	J	●																						
GP2	US CND AUS Vietnam		●	●		●	●		●	●														
GP3	AEP UK		●	●	●	●	●	●				●	●	●		●	●	●	●	●	●			
GP4	E AR BR TW JE HK CH KR		●			●		●	●	●	●				●								●	●

## 5. REPAIR PARTS LIST

DISASSEMBLY

HARDWARE LIST

### 5-1. EXPLODED VIEWS

#### 5-1-1. CABINET BLOCK

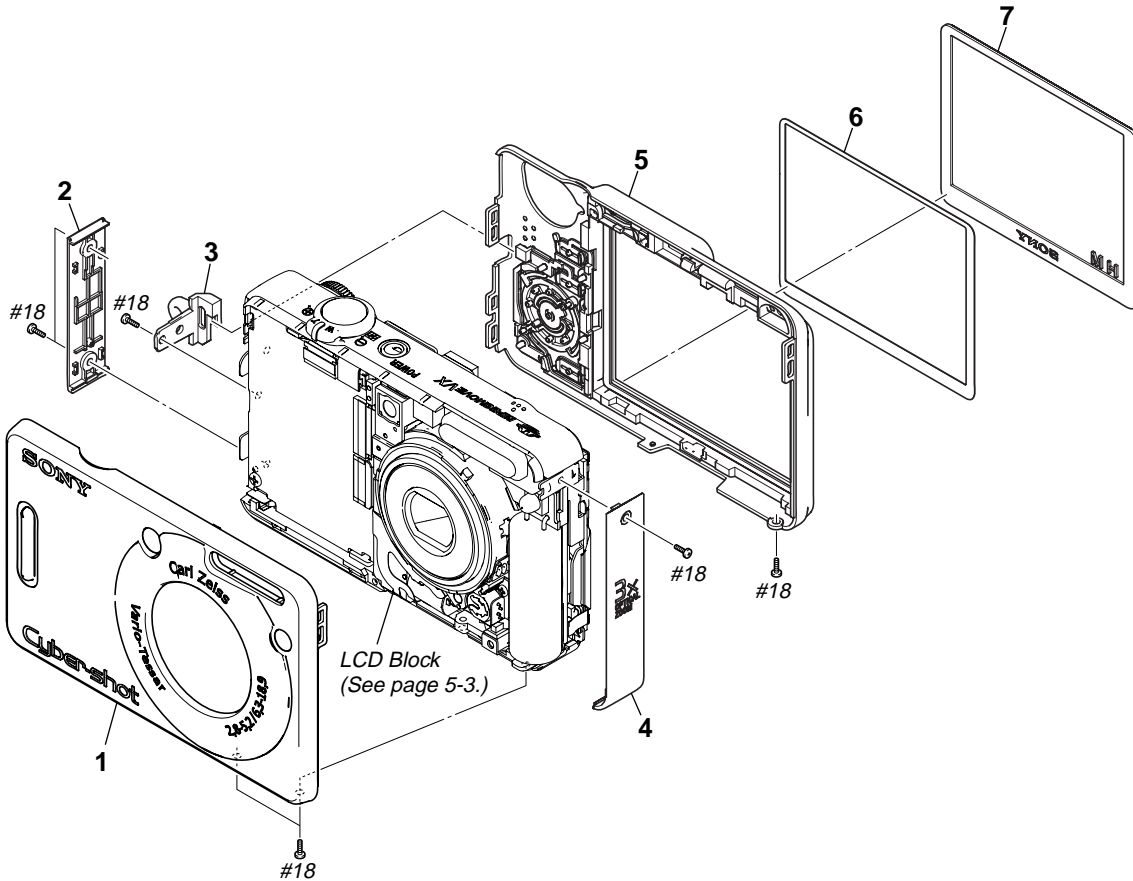

Ref. No.	Part No.	Description
1	A-1166-430-A	CABINET (FRONT) BLOCK ASSY (SILVER)
1	A-1166-433-A	CABINET (FRONT) BLOCK ASSY (BLACK)
2	2-666-506-01	CABINET, BT SIDE
3	2-666-418-01	BRACKET, STRAP
4	2-666-507-01	CABINET, LE SIDE

Ref. No.	Part No.	Description
5	A-1166-458-A	CABINET (REAR) BLOCK ASSY (SILVER)
5	A-1166-461-A	CABINET (REAR) BLOCK ASSY (BLACK)
6	2-666-491-01	SHEET (130), WINDOW ADHESIVE
7	2-666-505-01	WINDOW (130), LCD
#18	2-635-591-21	SCREW (M1.4), NEW TRUSTAR P2 (Silver)

## 5. REPAIR PARTS LIST

### DISASSEMBLY

### HARDWARE LIST

#### 5-1-2. LCD BLOCK

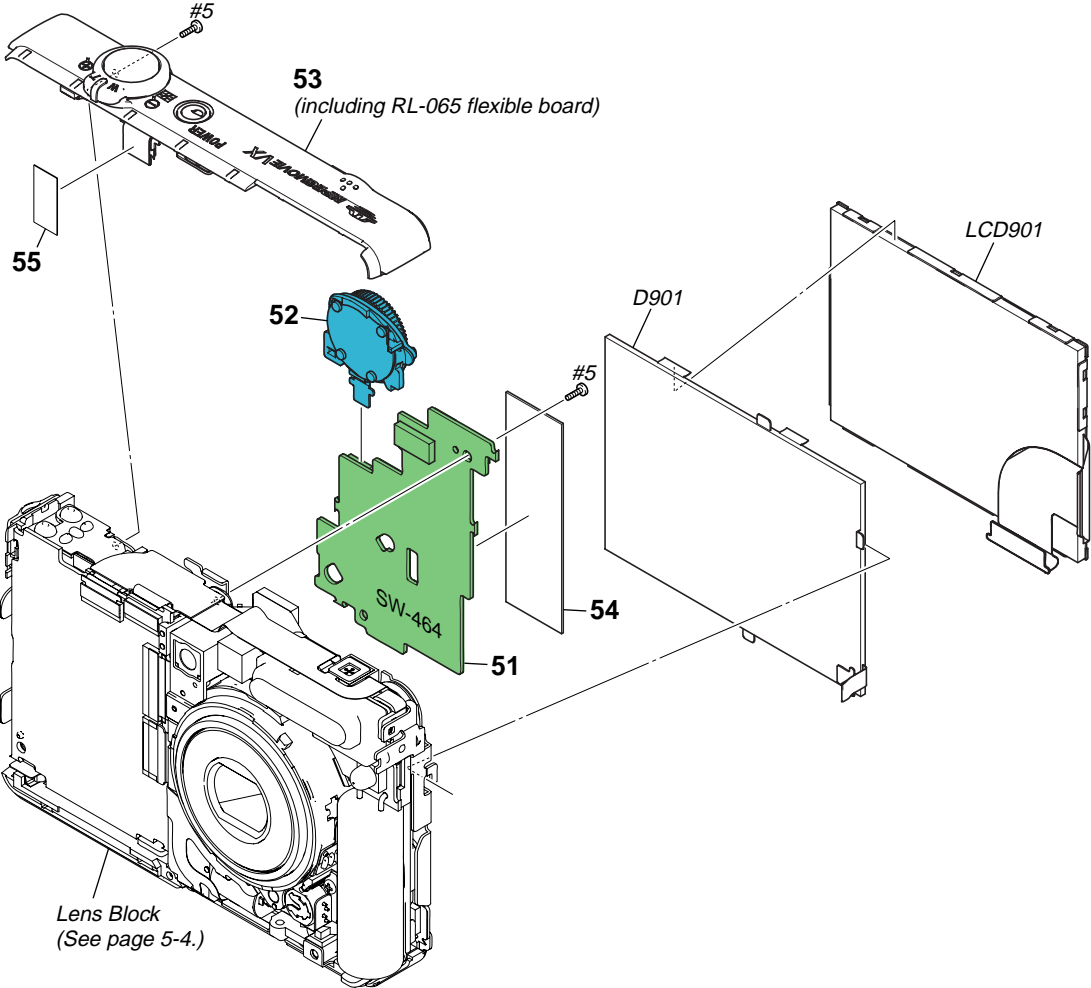

Ref. No.	Part No.	Description
51	A-1167-019-A	SW-464 BOARD, COMPLETE
52	1-479-584-11	CONTROL SW BLOCK (SW110T) (SILVER)
52	1-479-584-21	CONTROL SW BLOCK (SW120TB) (BLACK)
53	A-1166-159-A	CABINET (UPPER) BLOCK ASSY (including RL-065 flexible board)
* 54	2-666-428-01	SHEET (130), LCD REINFORCEMENT

Ref. No.	Part No.	Description
55	3-072-500-01	TAPE (N)
D901	1-479-554-21	BLOCK, LIGHT GUIDE PLATE (2.5)
LCD901	8-753-257-48	ACX336AKA-3
#5	3-080-204-01	SCREW, TAPPING, P2 (Black)

# 5. REPAIR PARTS LIST

## DISASSEMBLY

## HARDWARE LIST

### 5-1-3. LENS BLOCK

ns: not supplied

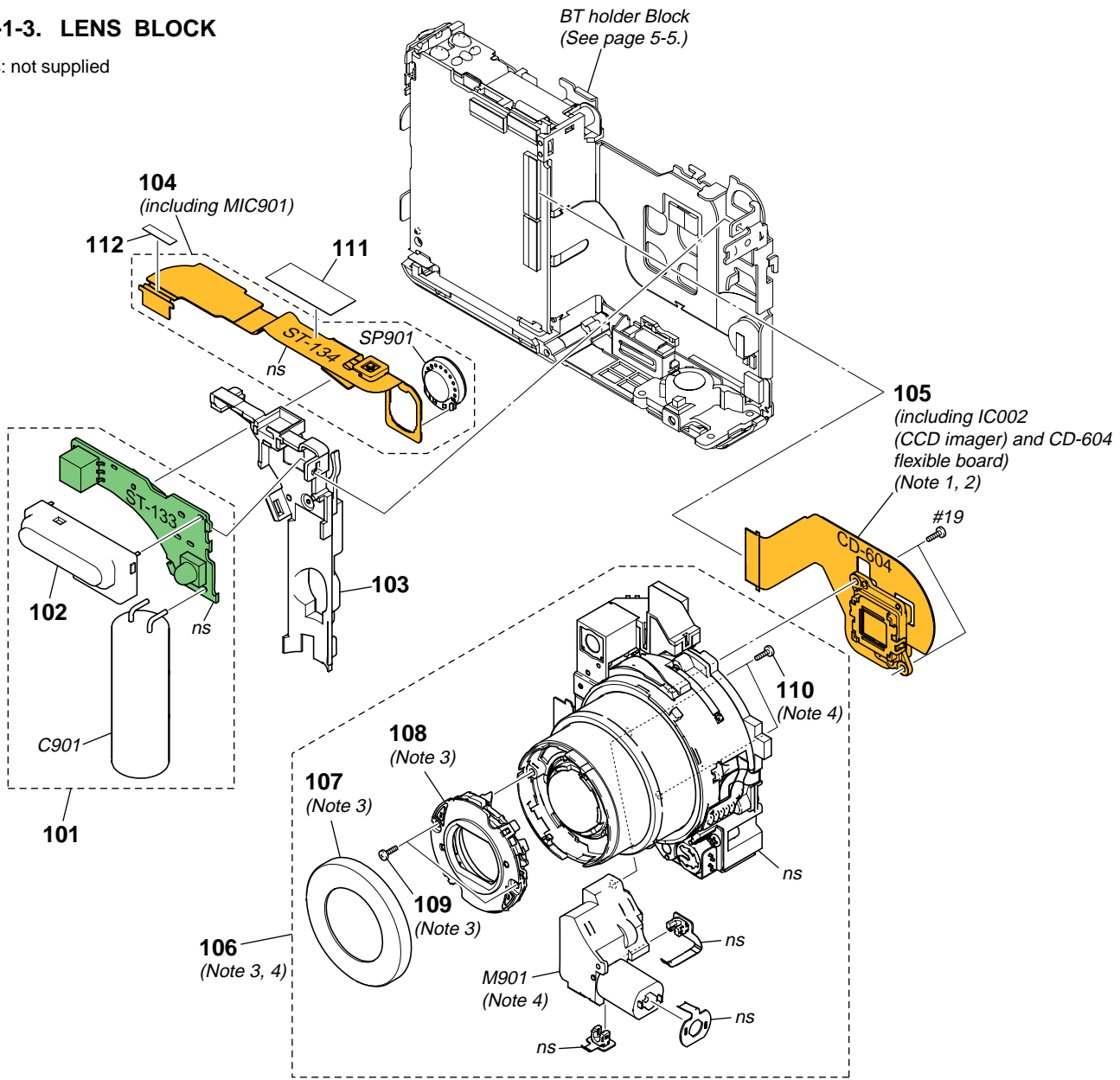

Note 1: CCD block assembly is including CD-604 flexible completed board.

Note 3: Be sure to read "Exchange method of barrier assembly" on page 2-6.

Note 2: Be sure to read "Precautions for Replacement of Imager" on page 4-3.

Note 4: Be sure to read "Exchange method of zoom motor unit" on page 2-9.

• Refer to page 5-1 for mark  $\Delta$ .

Ref. No.	Part No.	Description	Ref. No.	Part No.	Description
$\Delta$ 101	A-1182-558-A	ST-133 BOARD, COMPLETE	108	2-673-652-01	BARRIER ASSY (Note 3)
$\Delta$ 102	1-479-601-11	FLASH UNIT	109	2-673-651-01	TAPPING SCREW (B1.2X4) (Note 3)
* 103	2-666-420-01	HOLDER, STROBOSCOPE	110	2-673-649-01	BT2 P1.4X3 B3C (Note 4)
104	A-1183-052-A	ST-134 FLEXIBLE BOARD, COMPLETE (including MIC901)	111	3-941-343-01	TAPE (A)
105	A-1166-148-A	CCD BLOCK ASSY (including IC002 (CCD IMAGER) and CD-604 flexible board) (Note 1, 2)	* 112	2-678-568-01	SHEET, ST PROTECTION
106	1-788-363-11	OPTICAL UNIT (ED13A) (Note 3, 4)	$\Delta$ * C901	1-112-819-11	ELECT 97uF 315V
107	2-673-650-01	RING (A), ORNAMENTAL (Note 3)	M901	2-673-648-01	ZOOM MOTOR UNIT (Note 4)
			SP901	1-826-281-11	LOUDSPEAKER (1.0CM)
			#19	3-086-156-21	SCREW B1.2 (Red)

# 5. REPAIR PARTS LIST

## DISASSEMBLY

## HARDWARE LIST

### 5-1-4. BT HOLDER BLOCK

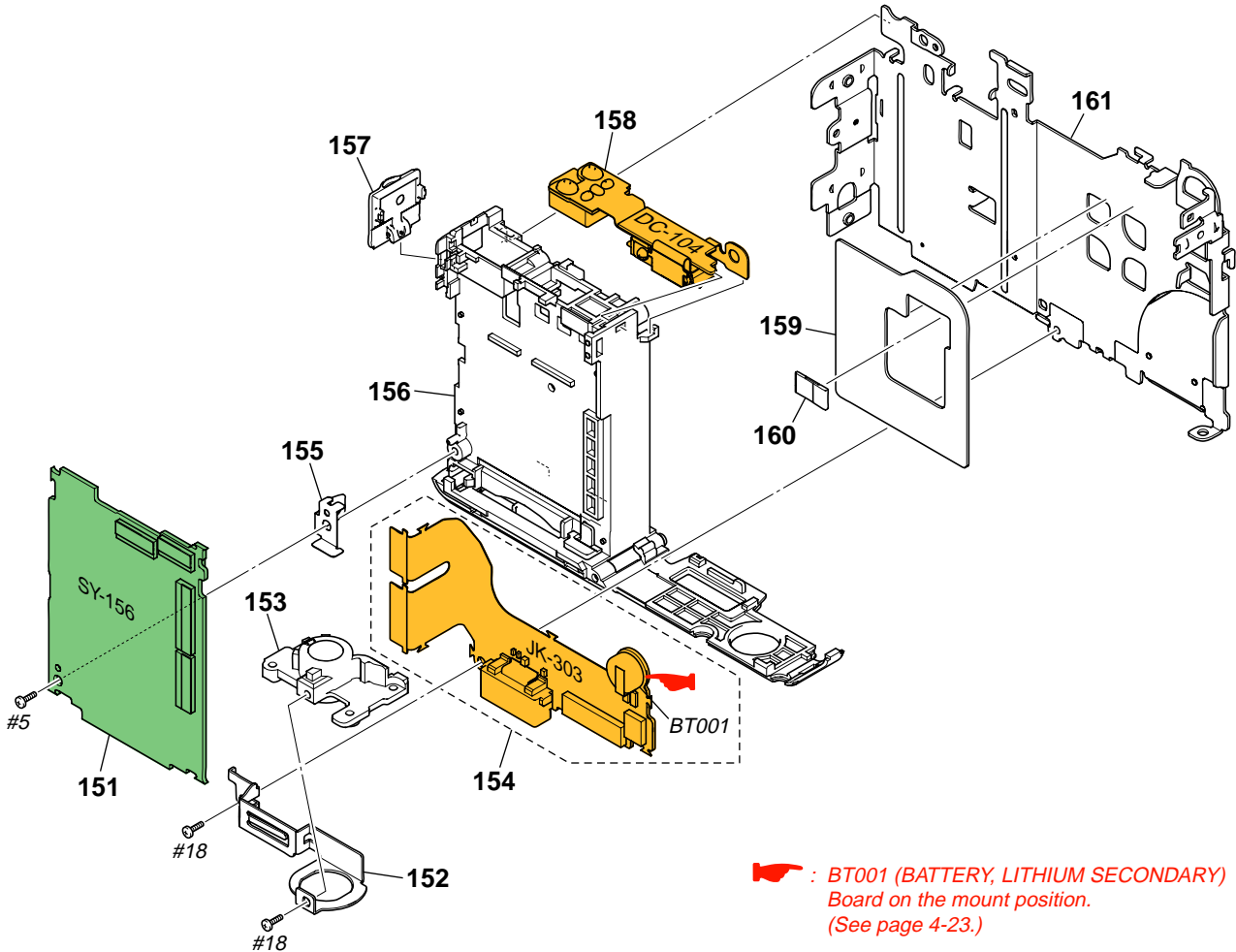

**CAUTION**  
 Danger of explosion if battery is incorrectly replaced.  
 Replace only with the same or equivalent type.

\* Refer to the table of page 5-1 about language of SY-156 board.

• Refer to page 5-1 for mark △.

Ref. No.	Part No.	Description
151	A-1191-615-A	SY-156 BOARD, COMPLETE (SERVICE) (GP4)
151	A-1191-616-A	SY-156 BOARD, COMPLETE (SERVICE) (GP2)
151	A-1191-617-A	SY-156 BOARD, COMPLETE (SERVICE) (GP3)
* 152	2-666-424-01	PLATE, MULTI FIXED
153	2-666-423-01	SCREW (130), TRIPOD
154	A-1166-050-A	JK-303 FLEXIBLE BOARD, COMPLETE
* 155	2-666-425-01	PLATE (130), BT GROUND
156	X-2108-259-1	HOLDER ASSY (130) (J), BT (SILVER)
156	X-2108-260-1	HOLDER ASSY (130) (J), BT (BLACK)

Ref. No.	Part No.	Description
157	2-666-426-01	LID (130), DC
158	A-1166-045-A	DC-104 FLEXIBLE BOARD, COMPLETE
* 159	2-666-427-01	CUSHION (130), LENS
* 160	2-666-429-01	CUSHION, CD RADIATION
* 161	2-666-422-01	FRAME (130), LCD
△BT001	1-528-999-61	BATTERY, LITHIUM SECONDARY
#5	3-080-204-01	SCREW, TAPPING, P2 (Black)
#18	2-635-591-21	SCREW (M1.4), NEW TRUSTAR P2 (Silver)

**5-2. ELECTRICAL PARTS LIST**

Ref. No.	Part No.	Description
	A-1166-148-A	CCD BLOCK ASSY (Note 1)
	(Not supplied)	CD-604 FLEXIBLE BOARD, COMPLETE
		*****
		(CD-604 flexible complete board and IC002 are not supplied, but they are included in CCD block assy.)
		< CAPACITOR >
C001	1-164-943-81	CERAMIC CHIP 0.01uF 10% 16V
C003	1-107-826-11	CERAMIC CHIP 0.1uF 10% 16V
C004	1-107-826-11	CERAMIC CHIP 0.1uF 10% 16V
C006	1-107-826-11	CERAMIC CHIP 0.1uF 10% 16V
C007	1-107-826-11	CERAMIC CHIP 0.1uF 10% 16V
C008	1-164-943-81	CERAMIC CHIP 0.01uF 10% 16V
		< IC >
IC001	8-753-230-85	IC CXA3691EN-T9
IC002	(Not supplied)	ICX629EQP-13 (Note 1)
		< RESISTOR >
R001	1-220-803-81	RES-CHIP 4.7 5% 1/16W
R002	1-218-990-81	SHORT CHIP 0
R004	1-218-979-11	RES-CHIP 150K 5% 1/16W
R008	1-164-943-81	CERAMIC CHIP 0.01uF 10% 16V
		(Note 2)
R009	1-218-977-11	RES-CHIP 100K 5% 1/16W
	A-1166-045-A	DC-104 FLEXIBLE BOARD, COMPLETE
		*****
		< BATTERY TERMINAL >
△ BH001	1-780-061-21	BATTERY TERMINAL BOARD
		< JACK >
J001	1-817-331-11	DC JACK 5P
		< LINE FILTER >
* LF001	1-457-217-21	COMMON MODE CHOKE COIL
	A-1166-050-A	JK-303 FLEXIBLE BOARD, COMPLETE
		*****
		(CN001 (multi connector) is not supplied, but this is included in JK-303 flexible complete board.)
		< BATTERY >
△ BT001	1-528-999-61	BATTERY, LITHIUM SECONDARY
		< CONNECTOR >
CN001	(Not supplied)	CONNECTOR, MULTIPLE (SOCKET)
* CN101	1-816-654-51	FFC/FPC CONNECTOR (LIF) 6P
* CN102	1-816-650-51	FFC/FPC CONNECTOR (LIF) 24P

Note 1: Be sure to read "Precautions for Replacement of Imager" on page 4-3 when changing the imager.

Note 2: Capacitor is mounted to the location where R008 is printed.

**CAUTION**  
 Danger of explosion if battery is incorrectly replaced.  
 Replace only with the same or equivalent type.

Ref. No.	Part No.	Description
		< FERRITE BEAD >
FB001	1-469-580-11	INDUCTOR, FERRITE BEAD (1005)
FB002	1-469-580-11	INDUCTOR, FERRITE BEAD (1005)
		< LINE FILTER >
LF001	1-456-583-11	COMMON MODE CHOKE COIL
	A-1166-159-A	CABINET (UPPER) BLOCK ASSY
	(Not supplied)	RL-065 FLEXIBLE BOARD, COMPLETE
		*****
		(RL-065 flexible complete board and S003 (shutter) are not supplied, but they are included in cabinet (upper) block assy.)
		< DIODE >
D001	6-500-776-01	DIODE MAZW068H0LS0
D002	6-500-594-01	DIODE CL-196SYG-CD-T (POWER)
D003	6-500-776-01	DIODE MAZW068H0LS0
		< RESISTOR >
R001	1-216-825-11	METAL CHIP 2.2K 5% 1/10W
		< SWITCH >
S002	1-786-157-11	SWITCH, TACTILE (POWER)
S003	(Not supplied)	TACTILE SWITCH (SHUTTER)
S005	1-786-180-31	SWITCH, PUSH (1KEY) (W (ZOOM)/INDEX)
S006	1-786-179-31	SWITCH, PUSH (1KEY) (T (ZOOM))
△	A-1182-558-A	ST-133 BOARD, COMPLETE
		*****
△	1-479-601-11	FLASH UNIT
		< CAPACITOR >
C001	1-162-964-11	CERAMIC CHIP 0.001uF 10% 50V
C002	1-131-860-11	TANTAL. CHIP 4.7uF 20% 10V
C003	1-131-860-11	TANTAL. CHIP 4.7uF 20% 10V
C004	1-165-908-11	CERAMIC CHIP 1uF 10% 10V
C005	1-125-777-11	CERAMIC CHIP 0.1uF 10% 10V
△ C007	1-100-758-11	CERAMIC CHIP 0.047uF 10% 250V
△* C901	1-112-819-11	ELECT 97uF 315V
		< CONNECTOR >
CN001	1-815-762-51	CONNECTOR, FFC/FPC 14P
		< DIODE >
△* D002	6-501-433-01	DIODE MA2YF8000LS0
* D003	6-501-364-01	DIODE DOR5352
		(SELF-TIMER/AF ILLUMINATOR)
		< IC >
IC001	6-707-555-01	IC TPS65552RGTR
		< COIL >
* L001	1-400-820-11	INDUCTOR 2.2uH

• Refer to page 5-1 for mark △.

Ref. No.	Part No.	Description
		< TRANSISTOR >
△* Q001	6-551-447-01	TRANSISTOR TIG022TS-S-TL-E
		< RESISTOR >
R003	1-216-803-11	METAL CHIP 33 5% 1/10W
△R004	1-216-121-11	RES-CHIP 1M 5% 1/10W
R005	1-216-857-11	METAL CHIP 1M 5% 1/10W

Electrical parts list of the SY-156 board is not shown.  
Pages 5-8 to 5-11 are not shown.

		< TRANSFORMER >
△T001	1-443-648-21	DC-DC CONVERTER TRANSFORMER

A-1183-052-A ST-134 FLEXIBLE BOARD, COMPLETE  
\*\*\*\*\*  
(MIC901 is not supplied, but this is included in ST-134 flexible complete board.)

		< MICROPHONE >
MIC901	(Not supplied)	MICROPHONE BLOCK
		< SPEAKER >
SP901	1-826-281-11	LOUDSPEAKER (1.0CM)



A-1167-019-A SW-464 BOARD, COMPLETE  
\*\*\*\*\*

		< CONNECTOR >
* CN001	1-816-654-51	FFC/FPC CONNECTOR (LIF) 6P
* CN002	1-816-644-51	FFC/FPC CONNECTOR (LIF) 12P
		< DIODE >
D001	8-719-075-29	DIODE SML-510MWT86S (AE/AF LOCK/SELF-TIMER)
D002	8-719-077-34	DIODE SML-310YTT86 (FLASH CHARGING/RECORD)
		< RESISTOR >
R001	1-218-957-11	RES-CHIP 2.2K 5% 1/16W
R002	1-218-957-11	RES-CHIP 2.2K 5% 1/16W
R003	1-218-957-11	RES-CHIP 2.2K 5% 1/16W
R004	1-218-957-11	RES-CHIP 2.2K 5% 1/16W
R005	1-218-957-11	RES-CHIP 2.2K 5% 1/16W
R006	1-218-959-11	RES-CHIP 3.3K 5% 1/16W

		< SWITCH >
S001	1-786-885-41	SWITCH, TACTILE (▼ (SELF TIMER))
S002	1-786-885-41	SWITCH, TACTILE (SCREEN DISPLAY)
S003	1-786-885-41	SWITCH, TACTILE (▶ (PLAYBACK))
S004	1-786-885-41	SWITCH, TACTILE (► (MACRO))
S005	1-786-885-41	SWITCH, TACTILE (IMAGE SIZE/DELETE)
S006	1-786-885-41	SWITCH, TACTILE (▲ (FLASH))
S007	1-786-885-41	SWITCH, TACTILE (MENU)
S008	1-786-885-41	SWITCH, TACTILE (◀ (IMAGE BRIGHTNESS (EV)))
S009	1-786-885-41	SWITCH, TACTILE (● (SET))

• Refer to page 5-1 for mark △.

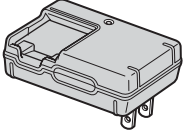
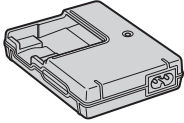
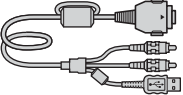
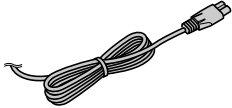
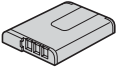
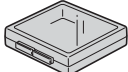
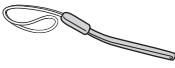
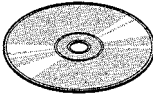
## Checking supplied accessories.

		<b>Other accessories</b>
<b>Battery Charger BC-CSG</b> ▲ 1-479-583-21 (US, CND)	<b>Battery Charger BC-CSG</b> ▲ 1-479-583-31 (EXCEPT US, CND)	
		2-673-237-21 INSTRUCTION (READ THIS FIRST) (FRENCH, ITALIAN) (AEP)
<b>USB/AV Cable for Multi-use Terminal</b> 1-829-866-31	<b>Power Cord</b> ▲ 1-555-074-71 (AUS) ▲ 1-782-476-41 (CH) ▲ 1-783-374-22 (HK) ▲ 1-783-952-51 (AR) ▲ 1-792-549-31 (JE) ▲ 1-823-947-51 (KR) ▲ 1-824-910-31 (AEP, E) ▲ 1-827-269-22 (UK)	2-673-237-31 INSTRUCTION (READ THIS FIRST) (SPANISH, PORTUGUESE) (AEP, E, AR, JE)
		2-673-237-41 INSTRUCTION (READ THIS FIRST) (GERMAN, DUTCH) (AEP)
<b>Rechargeable Battery Pack NP-BG1</b> (not supplied)	<b>Battery Case</b> (not supplied)	2-673-237-51 INSTRUCTION (READ THIS FIRST) (TRADITIONAL CHINESE, SIMPLIFIED CHINESE) (E, HK, CH, JE)
		2-673-237-61 INSTRUCTION (READ THIS FIRST) (RUSSIAN) (AEP)
<b>Wrist Strap</b> 2-050-981-01	<b>CD-ROM</b> (Cyber-shot Application Software) 2-666-673-01	2-673-237-71 INSTRUCTION (READ THIS FIRST) (ARABIC, PERSIAN) (E)
		2-673-237-81 INSTRUCTION (READ THIS FIRST) (KOREAN) (KR, JE)
<b>Conversion (2P) Adaptor</b> ▲ 1-569-007-12 (JE)	<b>Conversion (2P) Adaptor</b> ▲ 1-569-008-12 (E)	2-673-237-91 INSTRUCTION (READ THIS FIRST) (CZECH, POLISH) (AEP)
		2-673-238-11 INSTRUCTION (READ THIS FIRST) (HUNGARIAN, SLOVAK) (AEP)
		2-673-238-21 INSTRUCTION (READ THIS FIRST) (SWEDISH, FINNISH) (AEP)
		2-673-238-31 INSTRUCTION (READ THIS FIRST) (NORWEGIAN, DANISH) (AEP)
		2-673-368-11 INSTRUCTION (READ THIS FIRST) (ENGLISH) (US, CND)
		2-673-368-21 INSTRUCTION (READ THIS FIRST) (FRENCH, ITALIAN) (CND)
		2-673-239-11 INSTRUCTION (USER'S GUIDE) (ENGLISH) (EXCEPT KR, AR, CH)
		2-673-239-21 INSTRUCTION (USER'S GUIDE) (FRENCH, ITALIAN) (CND, AEP)
		2-673-239-31 INSTRUCTION (USER'S GUIDE) (SPANISH, PORTUGUESE) (AEP, E, AR, JE)
		2-673-239-41 INSTRUCTION (USER'S GUIDE) (GERMAN, DUTCH) (AEP)
		2-673-239-51 INSTRUCTION (USER'S GUIDE) (TRADITIONAL CHINESE, SIMPLIFIED CHINESE) (E, HK, CH, JE)
		2-673-239-61 INSTRUCTION (USER'S GUIDE) (RUSSIAN) (AEP)
		2-673-239-71 INSTRUCTION (USER'S GUIDE) (ARABIC, PERSIAN) (E)
		2-673-239-81 INSTRUCTION (USER'S GUIDE) (KOREAN) (KR, JE)
		2-673-239-91 INSTRUCTION (USER'S GUIDE) (CZECH, POLISH) (AEP)
		2-673-259-11 INSTRUCTION (USER'S GUIDE) (HUNGARIAN, SLOVAK) (AEP)
		2-673-259-21 INSTRUCTION (USER'S GUIDE) (SWEDISH, FINNISH) (AEP)
		2-673-259-31 INSTRUCTION (USER'S GUIDE) (NORWEGIAN, DANISH) (AEP)

• Refer to the page 5-1 for mark ▲.

## HARDWARE LIST (1/2)

#1: M1.7 X 2.5  
(Black)  
2-635-562-11

#2: M1.7 X 4.0  
(Black)  
2-635-562-31

#3: M1.7 X 2.5  
(Red)  
2-660-401-01

#4: M1.4 X 2.5 (Tapping)  
(Dark Silver)  
3-348-998-81

#5: M1.7 X 3.5 (Tapping)  
(Black)  
3-080-204-01

#6: M1.4 X 1.7  
(Silver)  
2-598-474-01

#7: M1.7 X 1.6  
(Black)  
7-627-552-18

#8: M1.7 X 3.5 (Tapping)  
(Silver)  
3-078-890-01

#9: M1.7 X 5.0 (Tapping)  
(Silver)  
3-078-890-21

#10: M1.7 X 4.0  
(Silver)  
2-599-475-31

#11: M1.7 X 4.0 (Tapping)  
(Silver)  
3-078-890-11

#12: M1.7 X 5.0 (Tapping)  
(Black)  
3-080-204-21

#13: M1.7 X 2.5 (Tapping)  
(Silver)  
3-085-397-01

#14: M1.7 X 2.5  
(Silver)  
2-599-475-11

#15: M1.4 X 1.5  
(Silver)  
3-062-214-01

#16: M1.4 X 2.5  
(Silver)  
2-586-337-01

#17: M1.7 X 1.5  
(Silver)  
2-586-389-01

#18: M1.4 X 2.5  
(Silver)  
2-635-591-21

#19: M1.2 X 4.0 (Tapping)  
(Red)  
3-086-156-21

#20: M1.4 X 3.0  
(Silver)  
2-635-591-31

## HARDWARE LIST (2/2)

#21: M1.4 X 3.0  
(Black)  
2-662-396-21

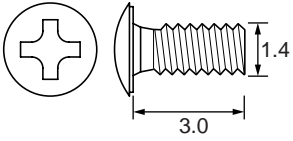

#22: M1.7 X 5.0 (Tapping)  
(Silver)  
3-083-261-01

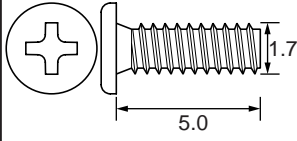

#23: M1.7 X 4.0 (Tapping)  
(Black)  
3-080-204-11

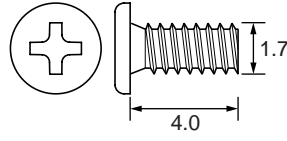

#24: B1.7 X 5.5 (Tapping)  
(Black)  
4-679-805-11

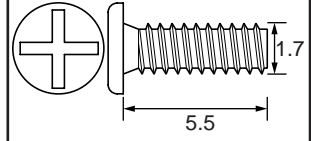

#25: M1.7 X 3.0  
(Black)  
2-635-562-21

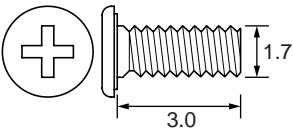

#26: M1.4 X 2.0  
(Silver)  
2-635-591-11

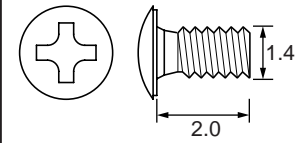

#27: M1.4 X 2.0  
(Black)  
2-662-396-11

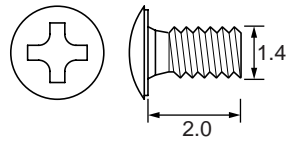

#28: M1.4 X 4.0 (Tapping)  
(Dark Silver)  
3-348-998-61

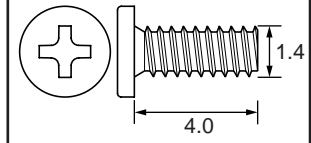

#29: M1.4 X 2.5  
(Black)  
2-662-396-01

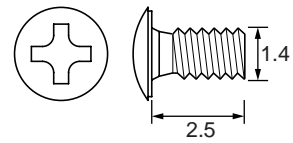

#30: M1.2 X 4.0 (Tapping)  
(White)  
3-086-156-11

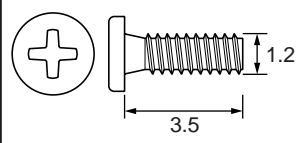

**[Description of main button functions on toolbar of the Adobe Acrobat Reader Ver5.0 (for Windows)]**

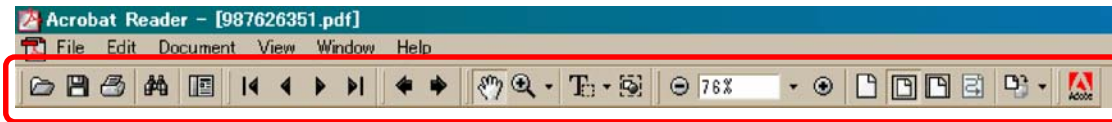

**Toolbar**



**Printing a text**

1. Click the Print button .
2. Specify a printer, print range, number of copies, and other options, and then click [OK].

**Application of printing:**

To set a range to be printed within a page, select the graphic selection tool  and drag on the page to enclose a range to be printed, and then click the Print button.

**Reversing the screens displayed once**

- To reverse the previous screens (operation) one by one, click the .
- To advance the reversed screens (operation) one by one, click the .

**Application to the Service Manual:**

This function allows you to go and back between circuit diagram and printed circuit board diagram, and accordingly it will be convenient for the voltage check.

**Finding a text**

1. Click the Find button .
2. Enter a character string to be found into a text box, and click the [Find]. (Specify the find options as necessary)

**Application to the Service Manual:**

To execute “find” from current page toward the previous pages, select the check box “Find Backward” and then click the “Find”.

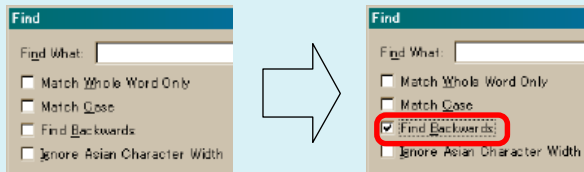





3. Open the find dialog box again, and click the [Find Again] and you can find the matched character strings displayed next. (Character strings entered previously are displayed as they are in the text box.)

**Application to the Service Manual:**

The parts on the drawing pages (block diagrams, circuit diagrams, printed circuit boards) and parts list pages in a text can be found using this find function. For example, find a Ref. No. of IC on the block diagram, and click the [Find Again] continuously, so that you can move to the Ref. No. of IC on the circuit diagram or printed circuit board diagram successively.

**Note:** The find function may not be applied to the Service Manual depending on the date of issue.

**Moving with link**

1. Select either palm tool , zoom tool , text selection tool , or graphic selection tool .
2. Place the pointer in the position in a text where the link exists (such as a button on cover and the table of contents page, or blue characters on the removal flowchart page or drawing page), and the pointer will change to the forefinger form .
3. Then, click the link. (You will go to the link destination.)

**Moving with bookmark:**

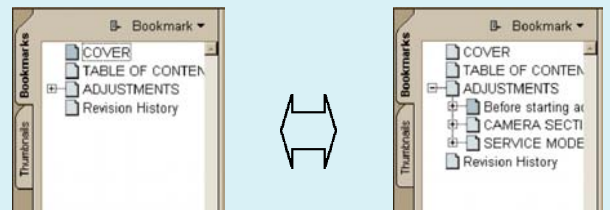

Click an item (text) on the bookmark pallet. and you can move to the link destination. Also, clicking  can display the hidden items.

(To go back to original state, click )



**Zooming or rotating the screen display**

**“Zoom in/out”**



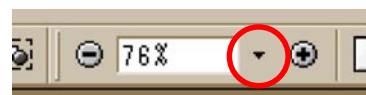

- Click the triangle button in the zoom control box to select the display magnification. Or, you may click  or  for zooming in or out.



**“Rotate”**

- Click rotate tool , and the page then rotates 90 degrees each.

**Switching a page**

- To move to the first page, click the .
- To move to the last page, click the .
- To move to the previous page, click the .
- To move to the next page, click the .

**Application to the Service Manual:**

The printed circuit board diagram you see now can be changed to the same direction as the set.

# Revision History

Ver.	Date	History	Contents	S.M. Rev. issued
1.0	2006.03	Official Release	—	—