

# DSC-T9

## SERVICE MANUAL

LEVEL 2

Ver 1.1 2005.12

Revision History

How to use  
Acrobat Reader

Internal memory  
ON BOARD



Photo: Silver

US Model  
Canadian Model  
AEP Model  
UK Model  
E Model  
Australian Model  
Hong Kong Model  
Chinese Model  
Korea Model  
Brazilian Model  
Japanese Model  
Tourist Model

### Link

<a href="#">SPECIFICATIONS</a>	<a href="#">BLOCK DIAGRAMS</a>	<a href="#">PRINTED WIRING BOARDS</a>
<a href="#">SERVICE NOTE</a>	<a href="#">FRAME SCHEMATIC DIAGRAM</a>	<a href="#">REPAIR PARTS LIST</a>
<a href="#">DISASSEMBLY</a>	<a href="#">SCHEMATIC DIAGRAMS</a>	

#### • Precaution on Replacing the SY-141 Board

The components identified by mark  $\triangle$  or dotted line with mark  $\triangle$  are critical for safety. Replace only with part number specified.

Les composants identifiés par une marque  $\triangle$  sont critiques pour la sécurité. Ne les remplacer que par une pièce portant le numéro spécifié.

DIGITAL STILL CAMERA

SONY®



Cyber-shot



## SPECIFICATIONS

### Camera

#### [System]

Image device	7.181 mm (1/2.5 type) color CCD, Primary color filter
Total pixel number of camera	Approx. 6 183 000 pixels
Effective pixel number of camera	Approx. 6 003 840 pixels
Lens	Carl Zeiss Vario-Tessar 3× zoom lens f = 6.33 – 19.0 mm (38 – 114 mm when converted to a 35 mm still camera) F3.5 – 4.3
Exposure control	Automatic exposure, Scene Selection (10 modes)
White balance	Automatic, Daylight, Cloudy, Fluorescent, Incandescent, Flash
File format (DCF compliant)	Still images: Exif Ver. 2.2 JPEG compliant, DPOF compatible Movies: MPEG1 compliant (Monaural)
Recording media	Internal Memory (58 MB) “Memory Stick Duo”
Flash	Recommended distance (ISO set to Auto): approx. 0.1 m to 2.8 m (3 15/16 inches to 9 feet 2 1/4 inches) (W)/approx. 0.25 m to 2.3 m (9 27/32 inches to 7 feet 6 9/16 inches) (T)

#### [Input and Output connectors]

Multi connector

USB communication

Hi-Speed USB (USB 2.0 compliant)

#### [LCD screen]

LCD panel	6.2 cm (2.5 type) TFT drive
Total number of dots	230 400 (960×240) dots

#### [Power, general]

Power	Rechargeable battery pack NP-FT1, 3.6 V AC-LS5K AC Adaptor (not supplied), 4.2 V
Power consumption (during shooting)	1.1 W
Operating temperature	0°C to +40°C (+32°F to +104°F)
Storage temperature	–20°C to +60°C (–4°F to +140°F)
Dimensions	89.7×54.9×20.6 mm (3 5/8×2 1/4×13/16 inches) (W/H/D, excluding protrusions)
Mass	Approx. 159g (5.6 oz) (including NP-FT1 battery pack and wrist strap, etc.)
Microphone	Electret condenser microphone
Speaker	Piezo-electric speaker
Exif Print	Compatible
PRINT Image Matching III	Compatible
PictBridge	Compatible

#### BC-CS3 battery charger

Power requirements	AC 100 to 240 V, 50/60 Hz, 3.2 W
Output voltage	DC 4.2 V, 500 mA
Operating temperature	0°C to +40°C (+32°F to +104°F)
Storage temperature	–20°C to +60°C (–4°F to +140°F)
Dimensions	Approx. 66×23×91 mm (2 5/8×29/32×3 5/8 inches) (W/H/D)
Mass	Approx. 70 g (2.7 oz)

#### Rechargeable battery pack NP-FT1

Used battery	Lithium-ion battery
Maximum voltage	DC 4.2 V
Nominal voltage	DC 3.6 V
Capacity	2.4 Wh (680 mAh)

Design and specifications are subject to change without notice.

**CAUTION**

Danger of explosion if battery is incorrectly replaced.  
Replace only with the same or equivalent type.

**SAFETY-RELATED COMPONENT WARNING!!**

**COMPONENTS IDENTIFIED BY MARK  $\triangle$  OR DOTTED LINE WITH MARK  $\triangle$  ON THE SCHEMATIC DIAGRAMS AND IN THE PARTS LIST ARE CRITICAL TO SAFE OPERATION. REPLACE THESE COMPONENTS WITH SONY PARTS WHOSE PART NUMBERS APPEAR AS SHOWN IN THIS MANUAL OR IN SUPPLEMENTS PUBLISHED BY SONY.**

**ATTENTION AU COMPOSANT AYANT RAPPORT À LA SÉCURITÉ!**

**LES COMPOSANTS IDENTIFIÉS PAR UNE MARQUE  $\triangle$  SUR LES DIAGRAMMES SCHÉMATIQUES ET LA LISTE DES PIÈCES SONT CRITIQUES POUR LA SÉCURITÉ DE FONCTIONNEMENT. NE REMPLACER CES COMPOSANTS QUE PAR DES PIÈCES SONY DONT LES NUMÉROS SONT DONNÉS DANS CE MANUEL OU DANS LES SUPPLÉMENTS PUBLIÉS PAR SONY.**

## SAFETY CHECK-OUT

After correcting the original service problem, perform the following safety checks before releasing the set to the customer.

1. Check the area of your repair for unsoldered or poorly-soldered connections. Check the entire board surface for solder splashes and bridges.
2. Check the interboard wiring to ensure that no wires are "pinched" or contact high-wattage resistors.
3. Look for unauthorized replacement parts, particularly transistors, that were installed during a previous repair. Point them out to the customer and recommend their replacement.
4. Look for parts which, through functioning, show obvious signs of deterioration. Point them out to the customer and recommend their replacement.
5. Check the B+ voltage to see it is at the values specified.
6. FLEXIBLE Circuit Board Repairing
  - Keep the temperature of the soldering iron around 270°C during repairing.
  - Do not touch the soldering iron on the same conductor of the circuit board (within 3 times).
  - Be careful not to apply force on the conductor when soldering or unsoldering.

### Unleaded solder

Boards requiring use of unleaded solder are printed with the lead-free mark (LF) indicating the solder contains no lead. (Caution: Some printed circuit boards may not come printed with the lead free mark due to their particular size.)



### : LEAD FREE MARK

Unleaded solder has the following characteristics.

- Unleaded solder melts at a temperature about 40°C higher than ordinary solder.  
Ordinary soldering irons can be used but the iron tip has to be applied to the solder joint for a slightly longer time.  
Soldering irons using a temperature regulator should be set to about 350°C.  
Caution: The printed pattern (copper foil) may peel away if the heated tip is applied for too long, so be careful!
- Strong viscosity  
Unleaded solder is more viscous (sticky, less prone to flow) than ordinary solder so use caution not to let solder bridges occur such as on IC pins, etc.
- Usable with ordinary solder  
It is best to use only unleaded solder but unleaded solder may also be added to ordinary solder.

## TABLE OF CONTENTS

<u>Section</u>	<u>Title</u>	<u>Page</u>
<b>1. SERVICE NOTE</b>		
1-1.	Description on Self-diagnosis Display .....	1-1
1-2.	Process After Fixing Flash Error .....	1-1
1-3.	Method for Copying or Erasing the Data in Internal Memory .....	1-2
1-4.	Precaution on Replacing the SY-141 Board .....	1-3
<b>2. DISASSEMBLY</b>		
2-1.	Disassembly .....	2-3
<b>3. BLOCK DIAGRAMS</b>		
3-1.	Overall Block Diagram (1/2) .....	3-1
3-2.	Overall Block Diagram (2/2) .....	3-3
3-3.	Power Block Diagram .....	3-5
<b>4. PRINTED WIRING BOARDS AND SCHEMATIC DIAGRAMS</b>		
4-1.	Frame Schematic Diagram .....	4-1
4-2.	Schematic Diagrams .....	4-5
4-3.	Printed Wiring Boards .....	4-27
4-4.	Waveforms .....	4-37
<b>5. REPAIR PARTS LIST</b>		
5-1.	Exploded Views .....	5-2
5-2.	Electrical Parts List .....	5-5

# 1. SERVICE NOTE

## 1-1. DESCRIPTION ON SELF-DIAGNOSIS DISPLAY

### Self-diagnosis display

The camera has a self-diagnosis display. This function displays the camera condition with five-digits (a combination of a letter and figures) on the LCD screen. If this occurs check the following code chart. The five-digits display informs you of the camera's current condition. The last two digits (indicated by □□) will differ depending on the state of the camera.

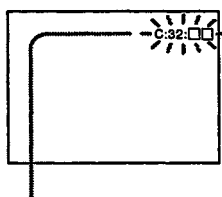

#### Self-diagnosis display

- C: □□: □□

You can reverse the camera malfunction yourself. (However, contact your Sony dealer or local authorized Sony service facility when you cannot recover from the camera malfunction.)

- E: □□: □□

Contact your Sony dealer or local authorized Sony service facility.

Display Code	Countermeasure	Cause	Caution Display During Error
C:32:□□	Turn the power off and on again.	Trouble with hardware.	SYSTEM ERROR
C:13:□□	Format the "Memory Stick" or internal memory.	"Memory Stick" or internal memory is unformatted.	FORMAT ERROR
	Insert a new "Memory Stick".	"Memory Stick" is broken.	MEMORY STICK ERROR
	Turn the power off and on again.	Trouble with internal memory.	INTERNAL MEMORY ERROR
E:61:□□	Checking of lens drive circuit.	When failed in the focus and zoom initialization.	—
E:62:□□	Inspect angular velocity sensor Peripheral circuits.	Steady shot function does not work well.	
E:91:□□	Checking of flash unit or replacement of flash unit. (Note)	Abnormality when flash is being charged.	

**Note:** After repair, be sure to perform "1-2. PROCESS AFTER FIXING FLASH ERROR".

## 1-2. PROCESS AFTER FIXING FLASH ERROR

When "FLASH error" (Self-diagnosis Code E : 91 : \*\* ) occurs, to prevent any abnormal situation caused by high voltage, setting of the flash is changed automatically to disabling charge and flash setting.

After fixing, this setting needs to be deactivated. Flash error code can be initialized by the operations on the Setup screen.

### Method for Initializing the Flash Error Code

Initialize		
Initializes the setting to the default setting.		
	OK	See the following procedure.
✓	Cancel	Cancels the resetting.

- ① Select [OK] with ▲ on the control button, then press ●.  
The message "Initialize all settings Ready?" appears.
  - ② Select [OK] with ▲, then press ●.  
The settings are reset to the default setting.
- Make sure that the power is not disconnected during resetting.

## 1-3. METHOD FOR COPYING OR ERASING THE DATA IN INTERNAL MEMORY (INTERNAL MEMORY/MUSIC)

The data can be copied/erased by the operations on the Setup screen. (When erasing the data, execute formatting the internal memory.)

**Note 1:** When replacing the SY-141 board, erase the data in internal memory of the board before replacement.

**Note 2:** When replacing the SY-141 board or the IC401 on the SY-141 board, execute formatting and initialize the internal memory after replacement.

### Method for Copying the Data in Internal Memory



#### Copy

Copies all images in the internal memory to a "Memory Stick Duo".

<input type="checkbox"/>	OK	See the following procedure.
<input checked="" type="checkbox"/>	Cancel	Cancels the copying.

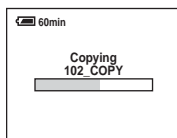
- ① Insert a "Memory Stick Duo" having 64 MB or larger capacity.
- ② Select [OK] with ▲ on the control button, then press ●.  
The message "All data in internal memory will be copied Ready?" appears.
- ③ Select [OK] with ▲, then press ●.  
Copying starts.



- Use a fully charged battery pack or the AC Adaptor (not supplied). If you attempt to copy image files using a battery pack with little remaining charge, the battery pack may run out, causing copying to fail or possibly corrupting the data.
- You cannot copy individual images.
- The original images in the internal memory are retained even after copying. To delete the contents of the internal memory, remove the "Memory Stick Duo" after copying, then execute the [Format] command in  (Internal Memory Tool).
- You cannot select a folder copied on a "Memory Stick Duo".
- Even if you copy data, a  (Print order) mark is not copied.

### Method for Formatting the Internal Memory

#### Format

Formats the internal memory.

- Note that formatting irrevocably erases all data in the internal memory, including even protected images.

<input type="checkbox"/>	OK	See the following procedure.
<input checked="" type="checkbox"/>	Cancel	Cancels the formatting.

- ① Select [OK] with ▲ on the control button, then press ●.  
The message "All data in internal memory will be erased Ready?" appears.
- ② Select [OK] with ▲, then press ●.  
The format is complete.

### Method for Formatting the Music

#### Format Music

If you cannot play back a Music file for the Slide Show, the Music file might be corrupted. If this happens, perform [Format Music].

When [Format Music] is performed, all the Music files are erased. Use the supplied software "Music Transfer" to activate [Download Music].

The message "All data will be erased Ready?" appears.

<input type="checkbox"/>	OK	Formats the Music files. All data other than Music files remain as it is.
<input checked="" type="checkbox"/>	Cancel	Cancels the formatting.

## 1-4. PRECAUTION ON REPLACING THE SY-141 BOARD

### VIDEO OUT Default Data Check

When you replace to the repairing board, the written data of repairing board also might be changed to original setting because of broadcast system (NTSC/PAL).

When the data has changed because of board replacing etc, check the default data of VIDEO OUT if destination code is right. If not, rewrite to the right value.

#### VIDEO OUT Default Data

Page	Address	Data	
		NTSC	PAL
4F	8D	00	01
4F	A2	00	01

#### Writing Method:

- 1) Select page: 00, address: 01 and set data: 01.
- 2) Select page: 4F, address: 8D, and set data: 00 (NTSC) or data: 01 (PAL).
- 3) Select page: 4F, address: A2, and set data: 00 (NTSC) or data: 01 (PAL).
- 4) Select page: 40, address: 38, and set data: 00.
- 5) Click **[Save]** on the SEUS screen.
- 6) Select page: 80, address: 34, and check that the data is "00".
- 7) Select page: 80, address: 30, and check that the data is "00".
- 8) Select page: 00, address: 01, and set data: 00.

### Initial Language Data Check

If the SY-141 board was replaced, initial language setting may be changed. Accordingly, change the following data so as to set same initial language as that of the set distributing in each region.

Initial language: Language displayed at the next starting if the setting of Setup menu was reset.

It is different from the language setting selectable with the menu.

#### Initial Language Data

Page	Address	Data	Language	GP1	GP2	GP3	GP4
4F	8C	00	English		●	●	●
		01	Japanese	●			
		04	Spanish			●	●
		06	Portugal				●
		08	Simplified Chinese				●
		0B	Russian				●
		0D	Korean				●

**Note:** GP1 is fixed to Japanese.

GP2 is fixed to English.

GP3 is either English, Spanish, or Russian.

GP4 is either English, Spanish, Portugal, Simplified Chinese, or Korean.

#### Writing Method:

- 1) Select page: 00, address: 01 and set data: 01.
- 2) Select page: 4F, address: 8C, and set the Initial Language Data.
- 3) Select page: 40, address: 38, and set data: 00.
- 4) Click **[Save]** on the SEUS screen.
- 5) Select page: 80, address: 34, and check that the data is "00".
- 6) Select page: 80, address: 30, and check that the data is "00".
- 7) Select page: 00, address: 01, and set data: 00.
- 8) Turn off the camera.
- 9) Turn on the camera. Execute "Initialize" of Setup screen.
- 10) Check the language displayed when the camera starts.

## 2. DISSASSEMBLY

### NOTE FOR REPAIR

- Make sure that the flat cable and flexible board are not cracked or bent at the terminal. Do not insert the cable insufficiently nor crookedly.
- When remove a connector, don't pull at wire of connector. It is possible that a wire is snapped.
- When installing a connector, don't press down at wire of connector. It is possible that a wire is snapped.
- Do not apply excessive load to the gilded flexible board.

Cut and remove the part of gilt which comes off at the point. (Be careful or some pieces of gilt may be left inside)

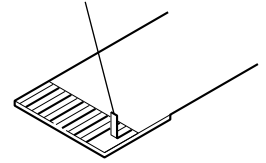

### DISCHARGING OF THE ST-131 BOARD'S CHARGING CAPACITOR (C328)

The charging capacitor (C328) of the ST-131 board is charged up to the maximum 300 V potential.

There is a danger of electric shock by this high voltage when the capacitor is handled by hand. The electric shock is caused by the charged voltage which is kept without discharging when the main power of the unit is simply turned off. Therefore, the remaining voltage must be discharged as described below.

#### Preparing the Short Jig

To preparing the short jig, a small clip is attached to each end of a resistor of 1 k $\Omega$  / 1 W (1-215-869-11).

Wrap insulating tape fully around the leads of the resistor to prevent electrical shock.

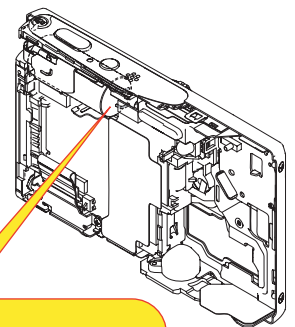
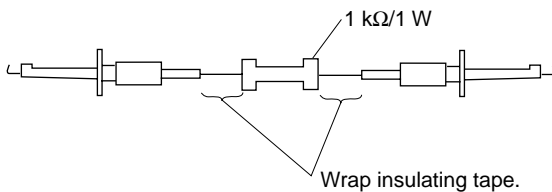

**Note:** High-voltage cautions

#### Discharging the Capacitor

Short-circuit between the two points with the short jig about 10 seconds.

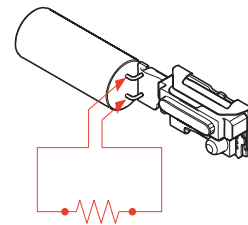

R:1 k $\Omega$ /1 W  
(Part code: 1-215-869-11)

The following flow chart shows the disassembly procedure.

2-1. DISASSEMBLY

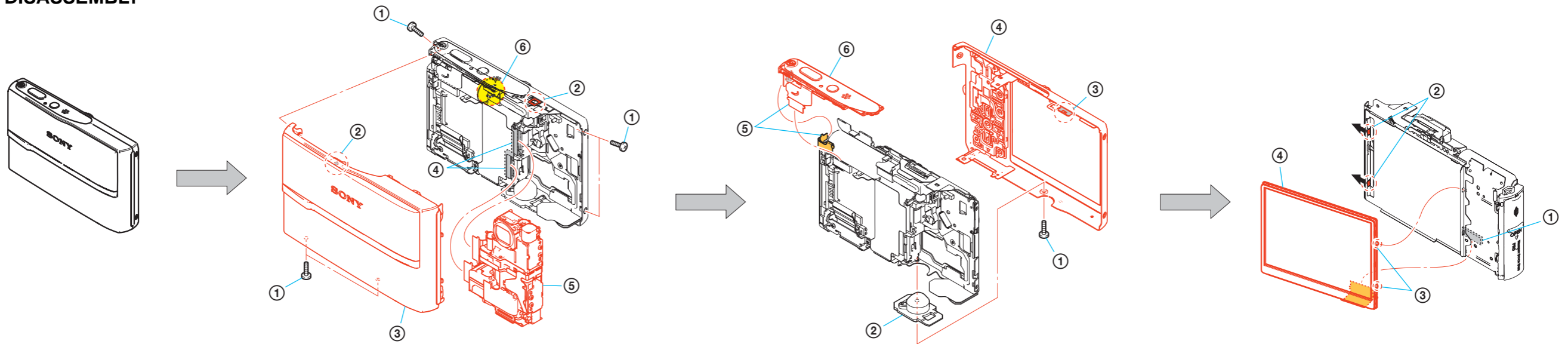

- ① P2 Screw (M1.4x2.5) (silver)/(black) x5
- ② Claw x2
- ③ Cabinet (front) assembly
- ④ Flexible board x2
- ⑤ Lens block
- ⑥ Discharging the Capacitor.

Refer to page 2-1  
" Discharging of the ST-131 board's  
charging capacitor (C328) ",  
when discharging the capacitor.

- ① P2 Screw (M1.4x2.5) (silver)/(black) x1
- ② Tripod screw x1
- ③ Claw x1
- ④ Cabinet (rear) block **HELP**
- ⑤ Flexible board x2
- ⑥ Control switch block **HELP**

- ① Connector x1
- ② Hook x2
- ③ Claw x2
- ④ D901, LCD901

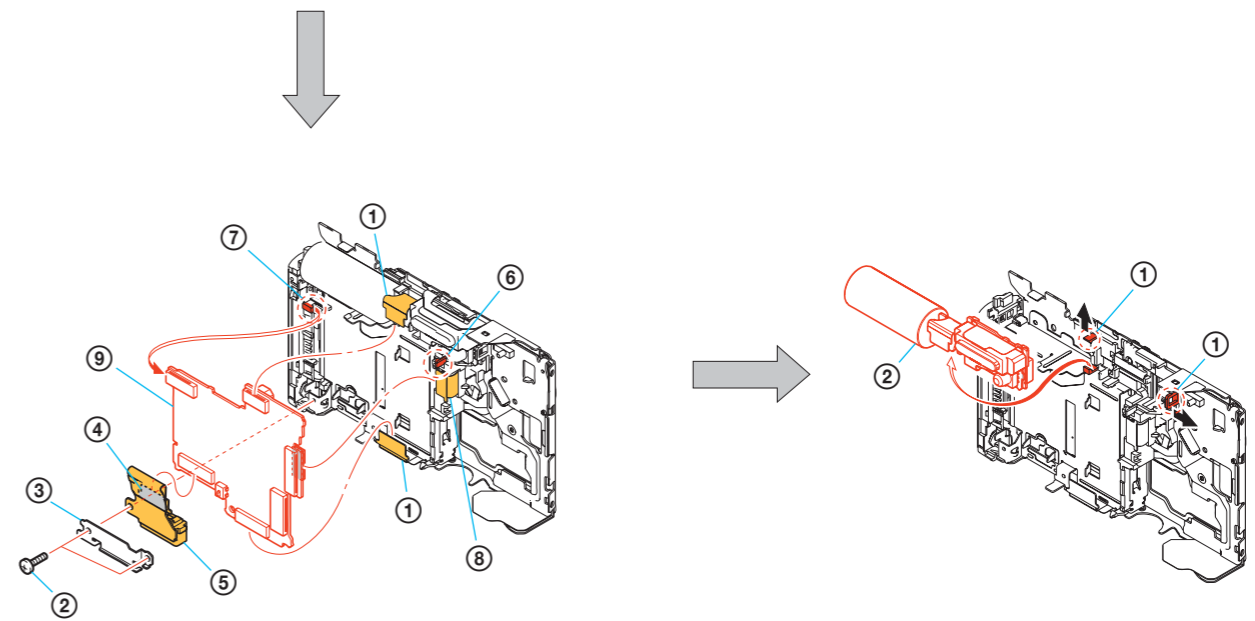

- ① Flexible board x2
- ② P2 Screw (M1.4x2.5) (silver) x2
- ③ Multi frame x1
- ④ Flexible board x1
- ⑤ MC flexible board x1
- ⑥ Claw x1
- ⑦ Hook x1
- ⑧ Flexible board x1
- ⑨ SY board

- ① Claw x2
- ② ST board

# HELP

Sheet attachment positions and procedures of processing the flexible boards/harnesses are shown.

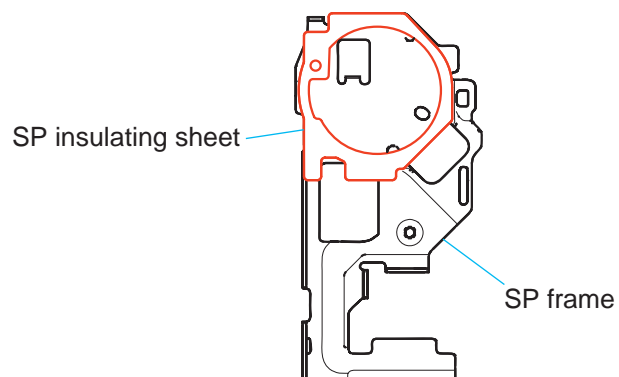
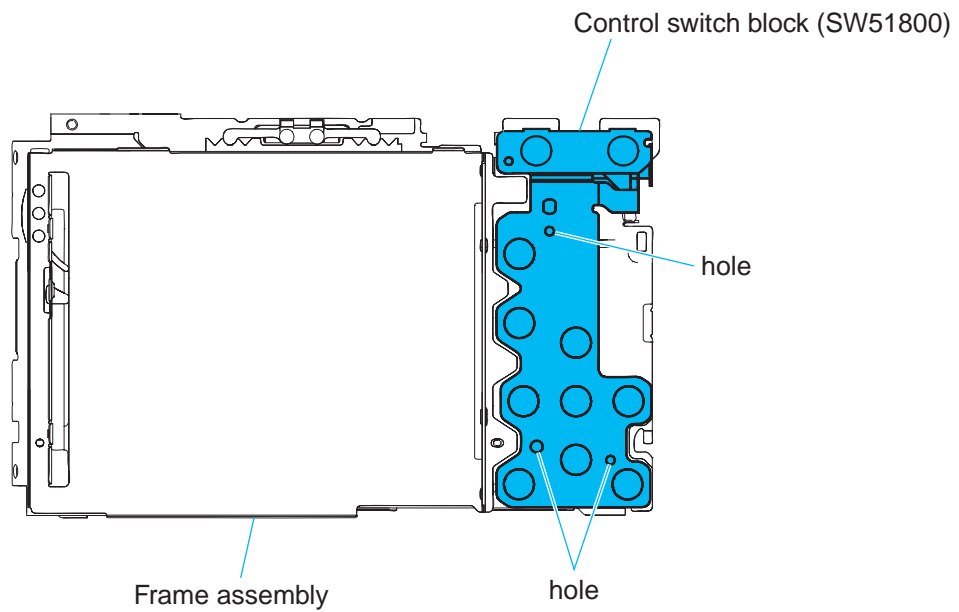
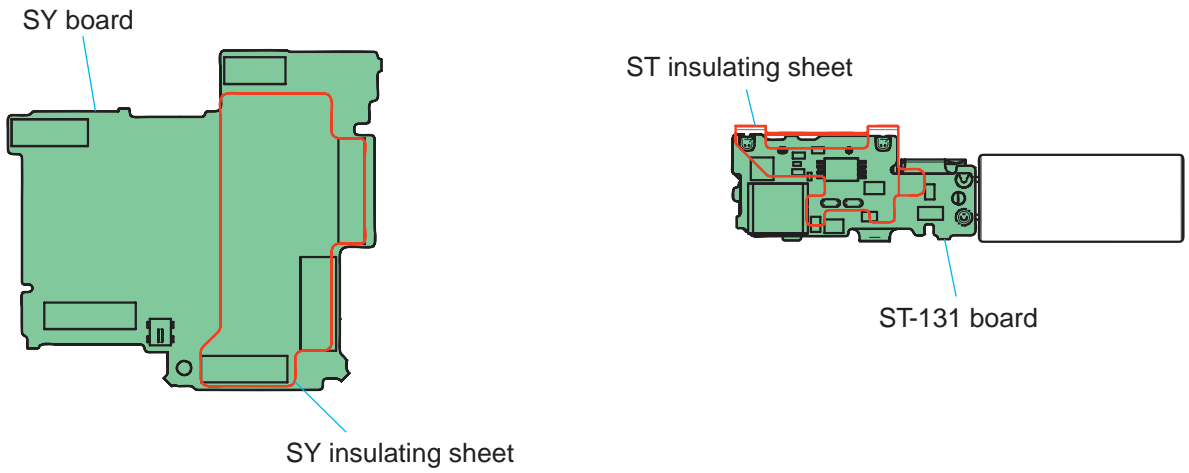

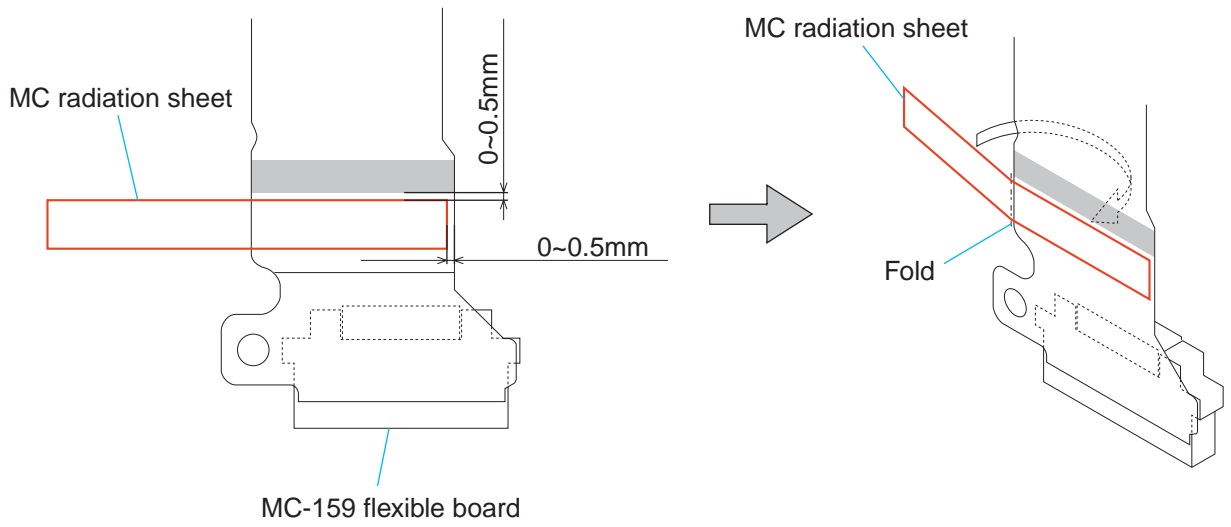
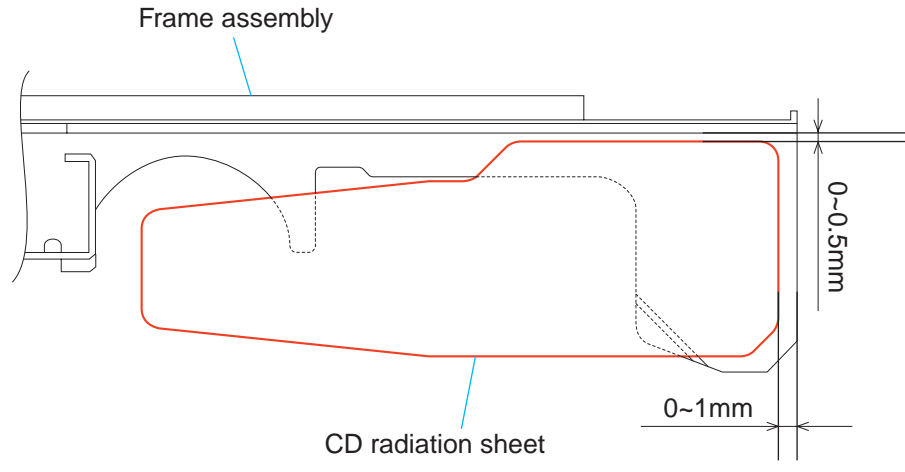

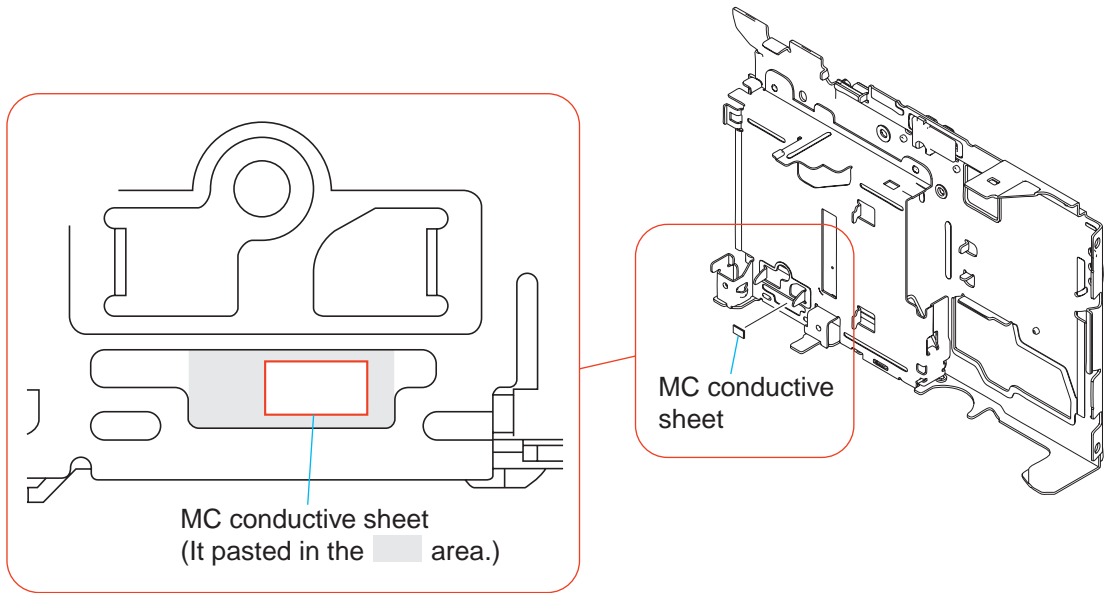

Note for installation of Control switch block (RL51800) and Cabinet (rear) block.

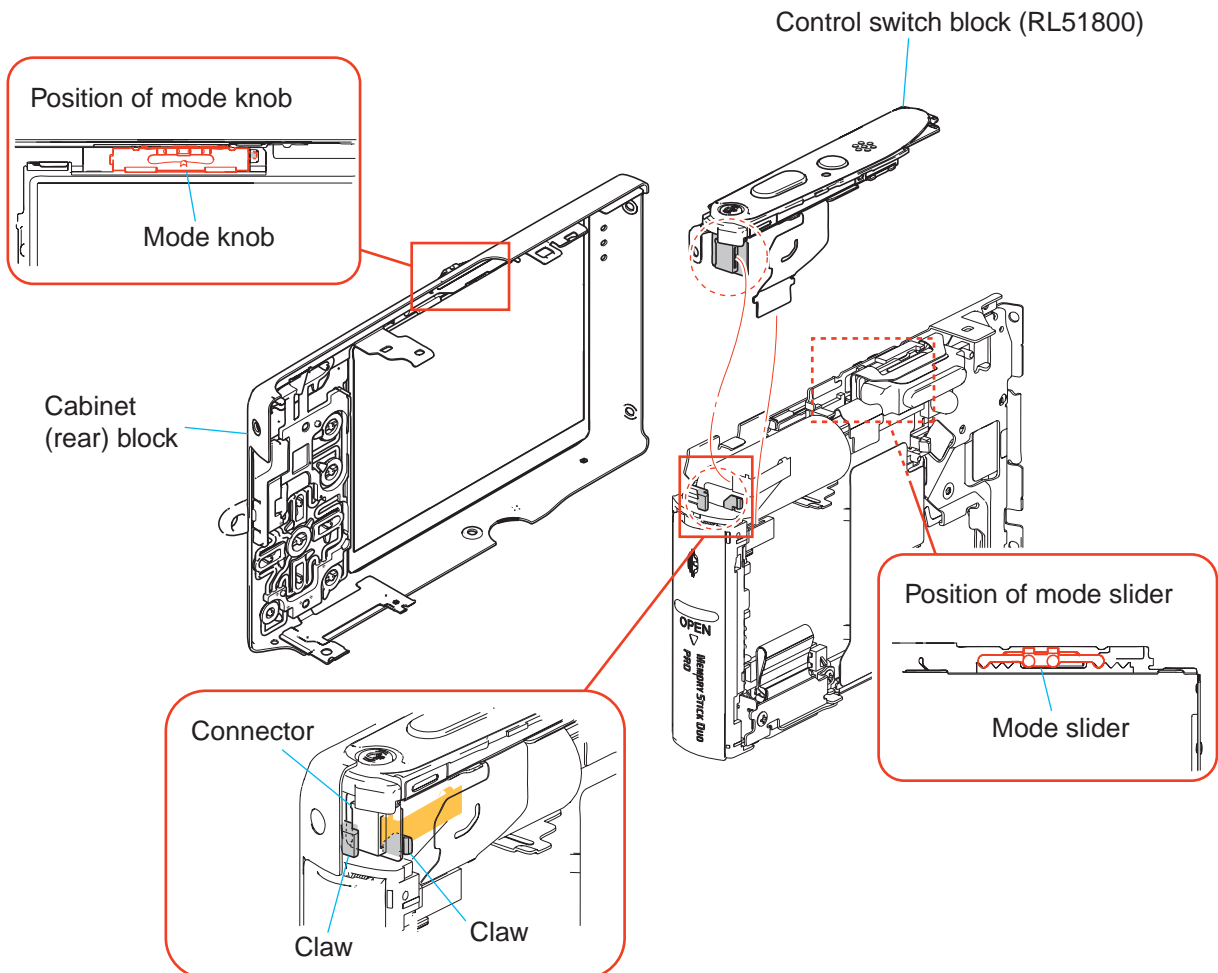

---

## 3. BLOCK DIAGRAMS

### Link

• [OVERALL BLOCK DIAGRAM \(1/2\)](#)

• [POWER BLOCK DIAGRAM](#)

• [OVERALL BLOCK DIAGRAM \(2/2\)](#)

### 3. BLOCK DIAGRAMS

3-1. OVERALL BLOCK DIAGRAM (1/2) ( ) : Number in parenthesis ( ) indicates the division number of schematic diagram where the component is located.

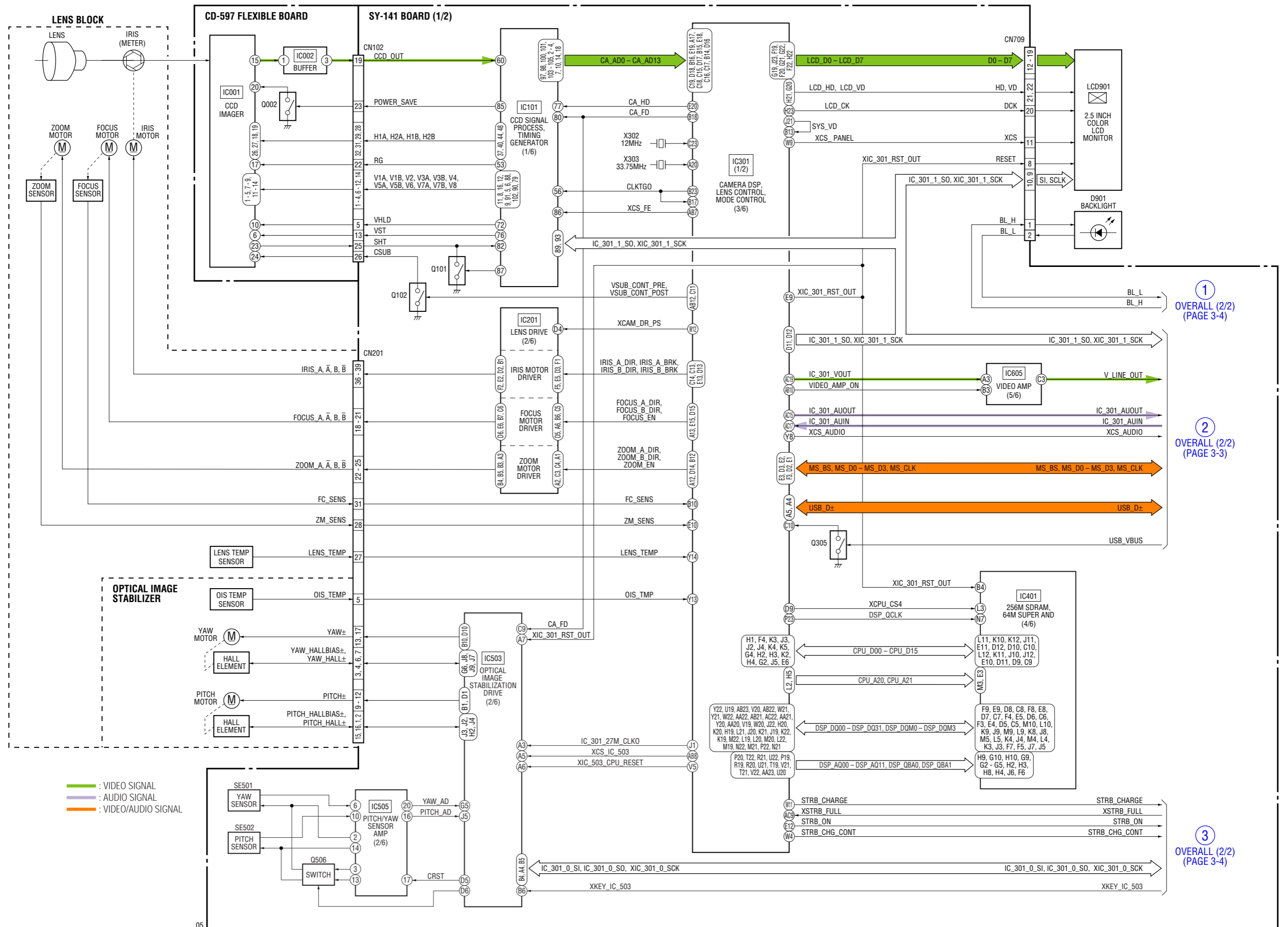



**3-3. POWER BLOCK DIAGRAM** ( ) : Number in parenthesis ( ) indicates the division number of schematic diagram where the component is located.

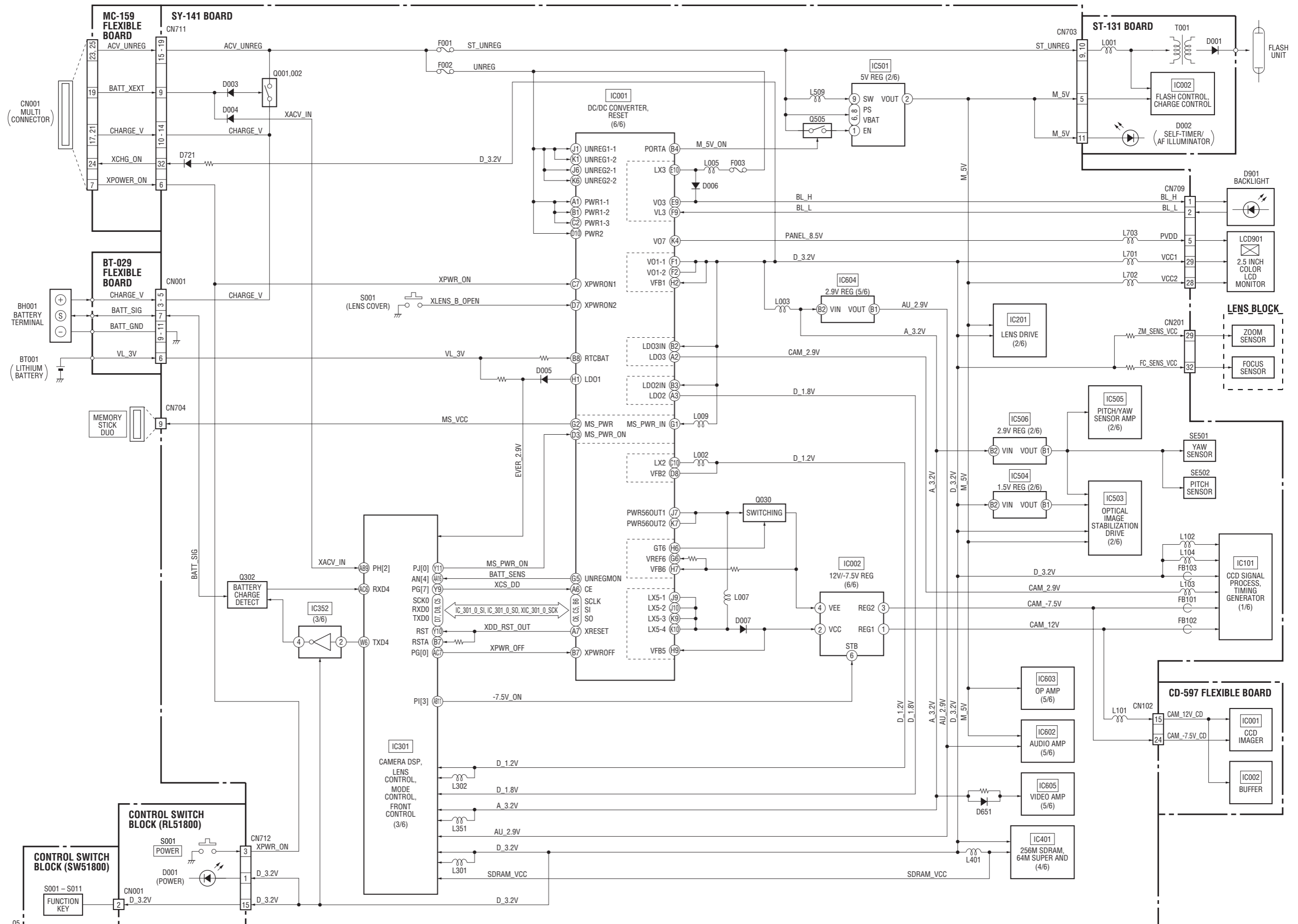

# 4. PRINTED WIRING BOARDS AND SCHEMATIC DIAGRAMS

## 4-1. FRAME SCHEMATIC DIAGRAM

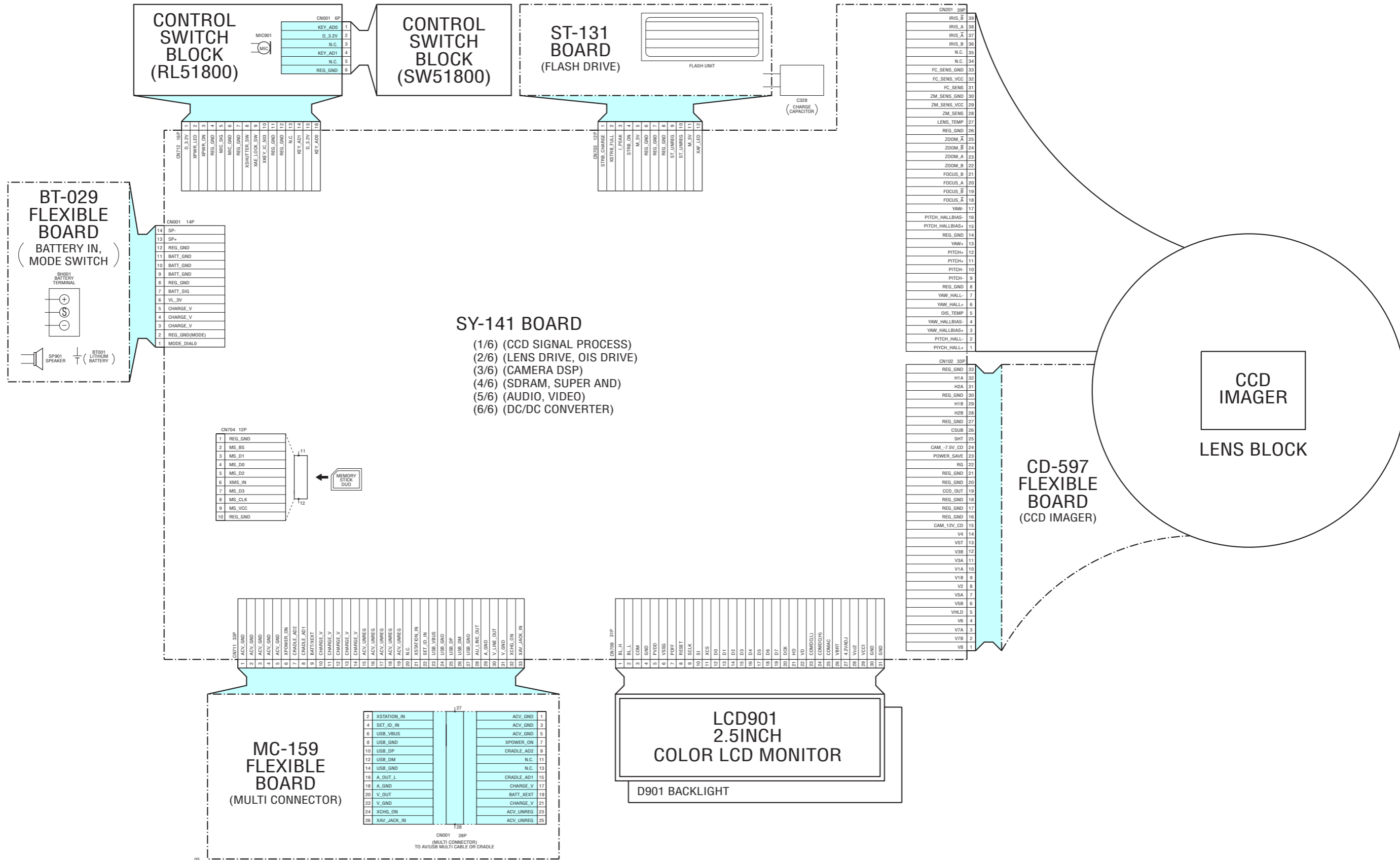

## 4-2. SCHEMATIC DIAGRAMS

### Link

<ul style="list-style-type: none"><li>• <b>CD-597 FLEXIBLE BOARD (CCD IMAGER)</b></li></ul>	<ul style="list-style-type: none"><li>• <b>BT-029 FLEXIBLE BOARD (BATTERY IN, MODE SWITCH)</b></li></ul>
<ul style="list-style-type: none"><li>• <b>ST-131 BOARD (FLASH DRIVE)</b></li></ul>	<ul style="list-style-type: none"><li>• <b>CONTROL SWITCH BLOCK (RL51800, SW51800)</b></li></ul>
<ul style="list-style-type: none"><li>• <b>MC-159 FLEXIBLE BOARD (MULTI CONNECTOR)</b></li></ul>	
<ul style="list-style-type: none"><li>• <b>COMMON NOTE FOR SCHEMATIC DIAGRAMS</b></li></ul>	<ul style="list-style-type: none"><li>• <b>WAVEFORMS</b></li></ul>

## 4-2. SCHEMATIC DIAGRAMS

### 4-2. SCHEMATIC DIAGRAMS

**THIS NOTE IS COMMON FOR SCHEMATIC DIAGRAMS**  
**(In addition to this, the necessary note is printed in each block)**

**(For schematic diagrams)**

- All capacitors are in  $\mu\text{F}$  unless otherwise noted.  $\text{pF} : \mu\text{F} : 50\text{V}$  or less are not indicated except for electrolytics and tantalums.
- Chip resistors are  $1/10\text{W}$  unless otherwise noted.  $\text{k}\Omega=1000\ \Omega$ ,  $\text{M}\Omega=1000\ \text{k}\Omega$ .
- Caution when replacing chip parts.  
New parts must be attached after removal of chip.  
Be careful not to heat the minus side of tantalum capacitor, Because it is damaged by the heat.
- Some chip part will be indicated as follows.

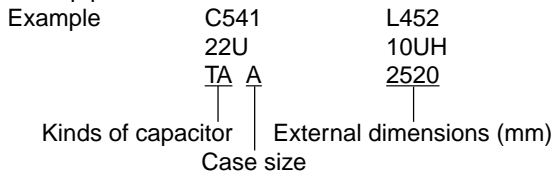

- Constants of resistors, capacitors, ICs and etc with XX indicate that they are not used.  
In such cases, the unused circuits may be indicated.
- Parts with  $\star$  differ according to the model/destination. Refer to the mount table for each function.
- All variable and adjustable resistors have characteristic curve B, unless otherwise noted.
- Signal name  
XEDIT  $\rightarrow$  EDIT      PB/XREC  $\rightarrow$  PB/REC
- : non flammable resistor
- : fusible resistor
- : panel designation
- : B+ Line
- : B- Line
- : IN/OUT direction of (+,-) B LINE.
- : adjustment for repair.
- : not use circuit
- Circled numbers refer to waveforms.

**(Measuring conditions voltage and waveform)**

- Voltages and waveforms are measured between the measurement points and ground when camera shoots color bar chart of pattern box. They are reference values and reference waveforms.  
(VOM of DC  $10\ \text{M}\Omega$  input impedance is used)
- Voltage values change depending upon input impedance of VOM used.)

**Precautions for Replacement of Imager**

- If the imager has been replaced, carry out all the adjustments for the camera section.
- As the imager may be damaged by static electricity from its structure, handle it carefully like for the MOS IC.  
In addition, ensure that the receiver is not covered with dusts nor exposed to strong light.

**1. Connection**

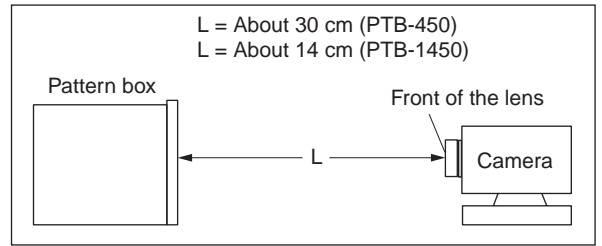
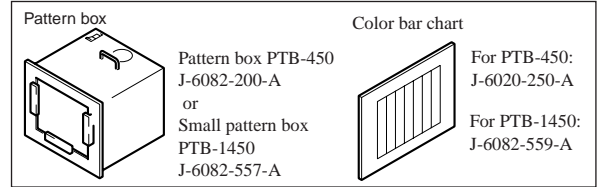

**2. Adjust the distance so that the output waveform of Fig. a and the Fig. b can be obtain.**

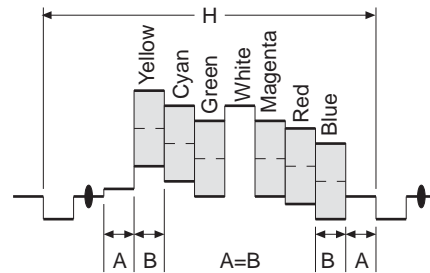

Fig. a (Video output terminal output waveform)

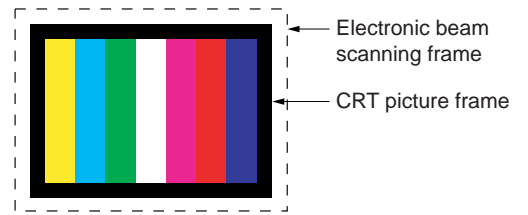

Fig.b (Picture on monitor TV)

When indicating parts by reference number, please include the board name.

The components identified by mark  $\triangle$  or dotted line with mark  $\triangle$  are critical for safety.  
Replace only with part number specified.

Les composants identifiés par une marque  $\triangle$  sont critiques pour la sécurité.  
Ne les remplacer que par une pièce portant le numéro spécifié.

# CD-597 FLEXIBLE BOARD

## CCD IMAGER

XX MARK:NO MOUNT

NO MARK:REC/PB MODE  
 R:REC MODE  
 P:PB MODE

Note: CD-597 flexible complete board, IC001 and IC002 are not supplied, but they are included in CCD block assy.

Note: Voltages and Waveforms of IC001 can not be measured, because this is mounted by the side of the lens.

A  
B  
C  
D  
E  
F  
G  
H

SY-141  
 (1/6)  
 CN102  
 (PAGE 4-9  
 of LEVEL3)

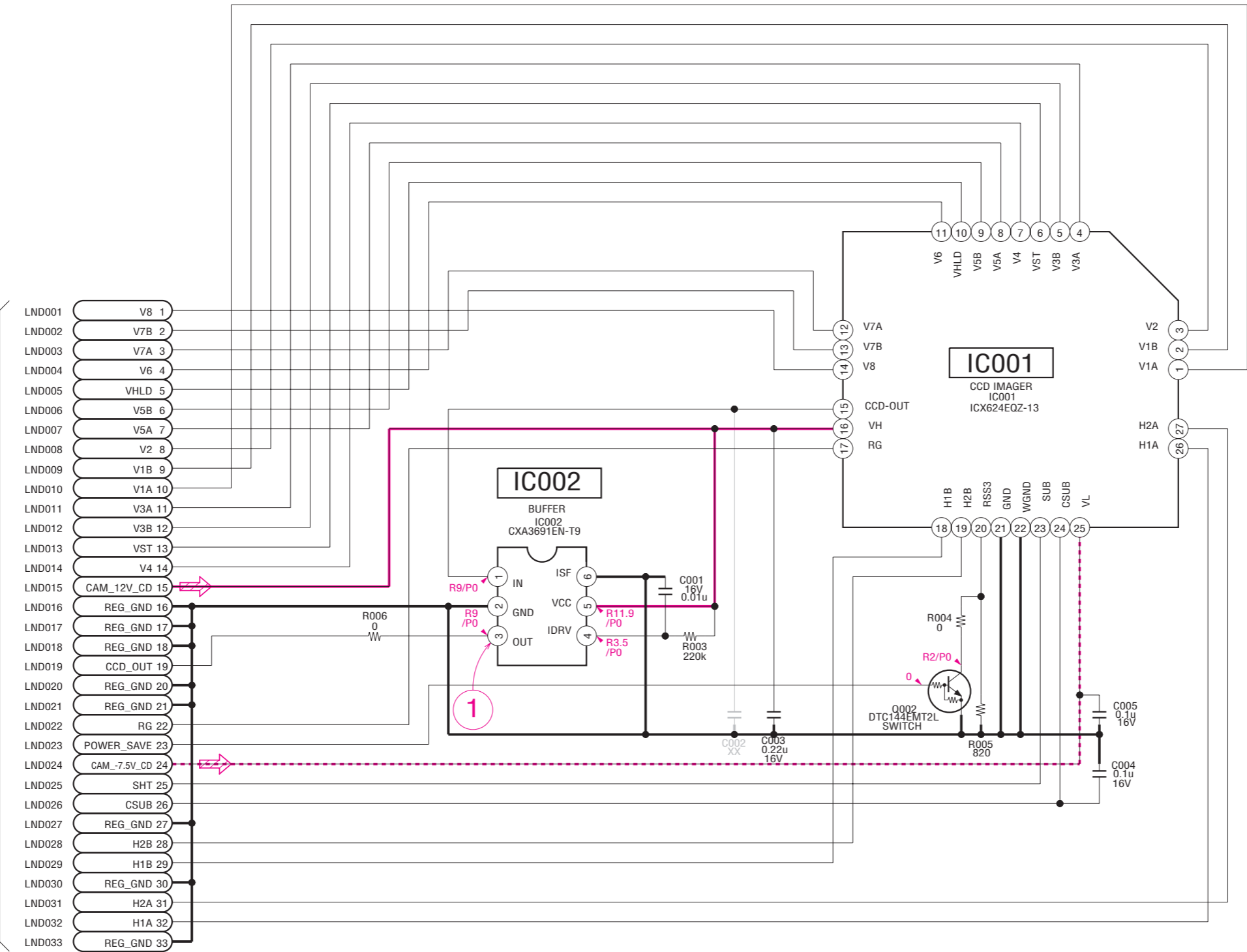

Schematic diagrams of the SY-141 board are not shown.  
Pages from 4-9 to 4-20 are not shown.





A  
B  
C  
D  
E  
F

SY-141  
(5/6)  
CN712  
(PAGE 4-17  
of LEVEL3)

# CONTROL SWITCH BLOCK (RL51800)

(CONTROL SWITCH BLOCK (RL51800) is replaced as block, so that PRINTED WIRING BOARD is omitted.)

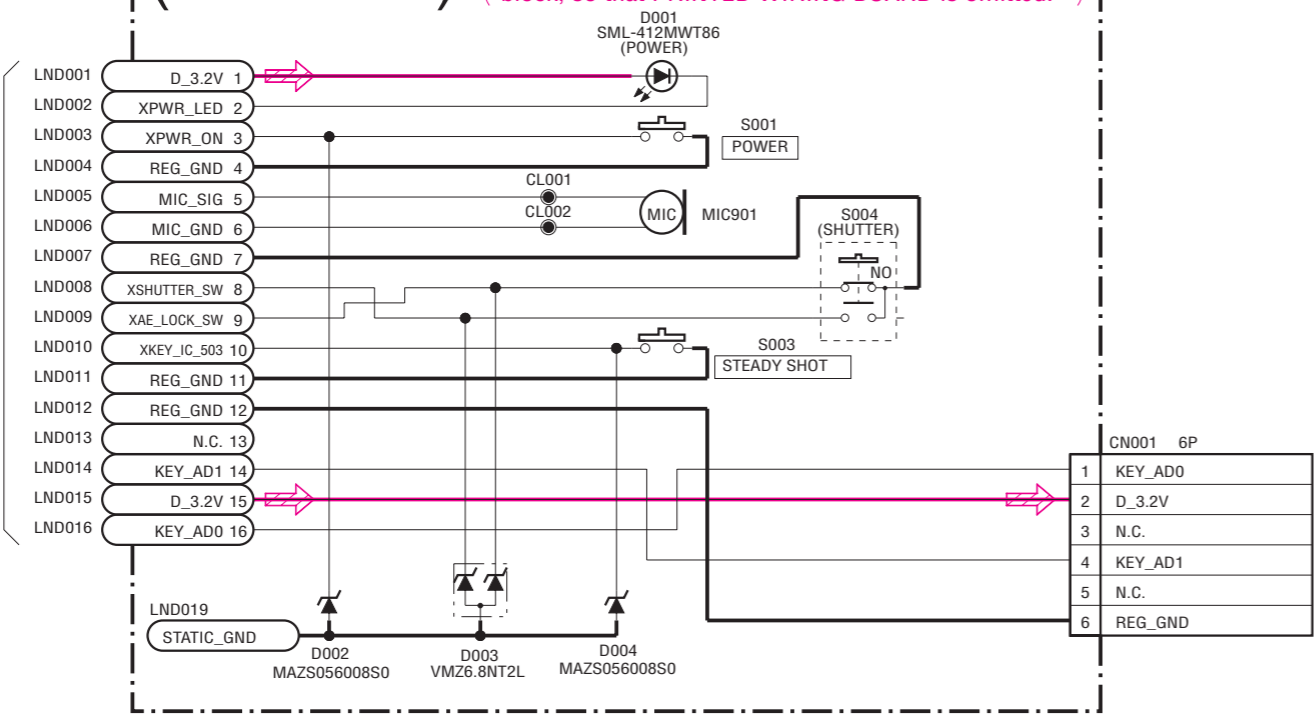

# CONTROL SWITCH BLOCK (SW51800)

(CONTROL SWITCH BLOCK (SW51800) is replaced as block, so that PRINTED WIRING BOARD is omitted.)

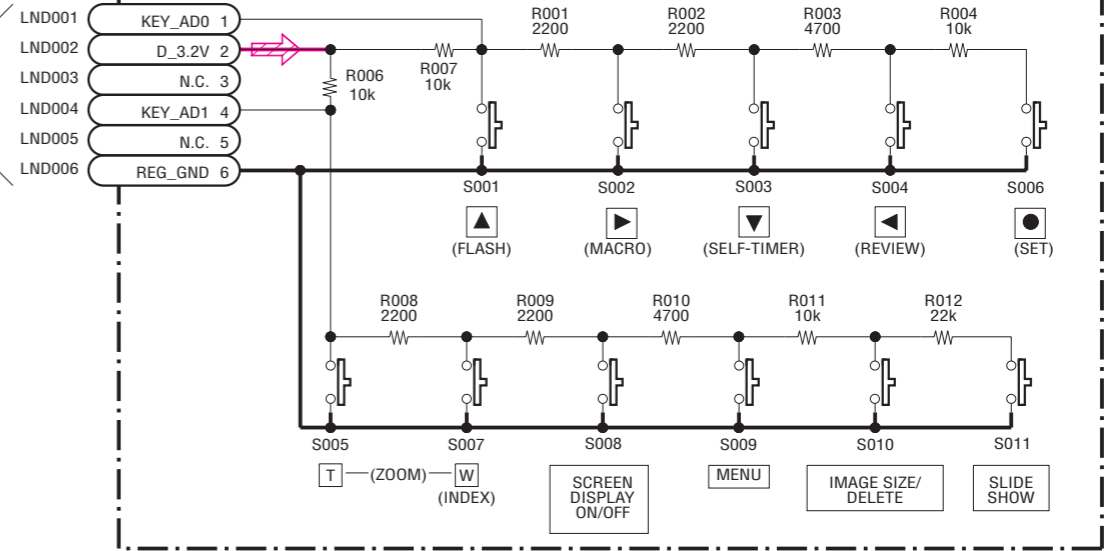

## 4-3. PRINTED WIRING BOARDS

### Link

[• CD-597 FLEXIBLE BOARD](#)

[• MC-159 FLEXIBLE BOARD](#)

[• ST-131 BOARD](#)

[• BT-029 FLEXIBLE BOARD](#)

[• COMMON NOTE FOR PRINTED WIRING BOARDS](#)

[• WAVEFORMS](#)

# 4-3. PRINTED WIRING BOARDS

## 4-3. PRINTED WIRING BOARDS

**THIS NOTE IS COMMON FOR PRINTED WIRING BOARDS**

- : Uses unleaded solder.
- : Circuit board
- : Flexible board
- : Pattern from the side which enables seeing.
- : pattern of the rear side  
(The other layers' patterns are not indicated)
- Through hole is omitted.
- Circled numbers refer to waveforms.
- There are a few cases that the part printed on diagram isn't mounted in this model.
- : panel designation

- Chip parts.

Transistor

Diode

CD-597 (2 layers)

 : Uses unleaded solder.

### CD-597 FLEXIBLE BOARD

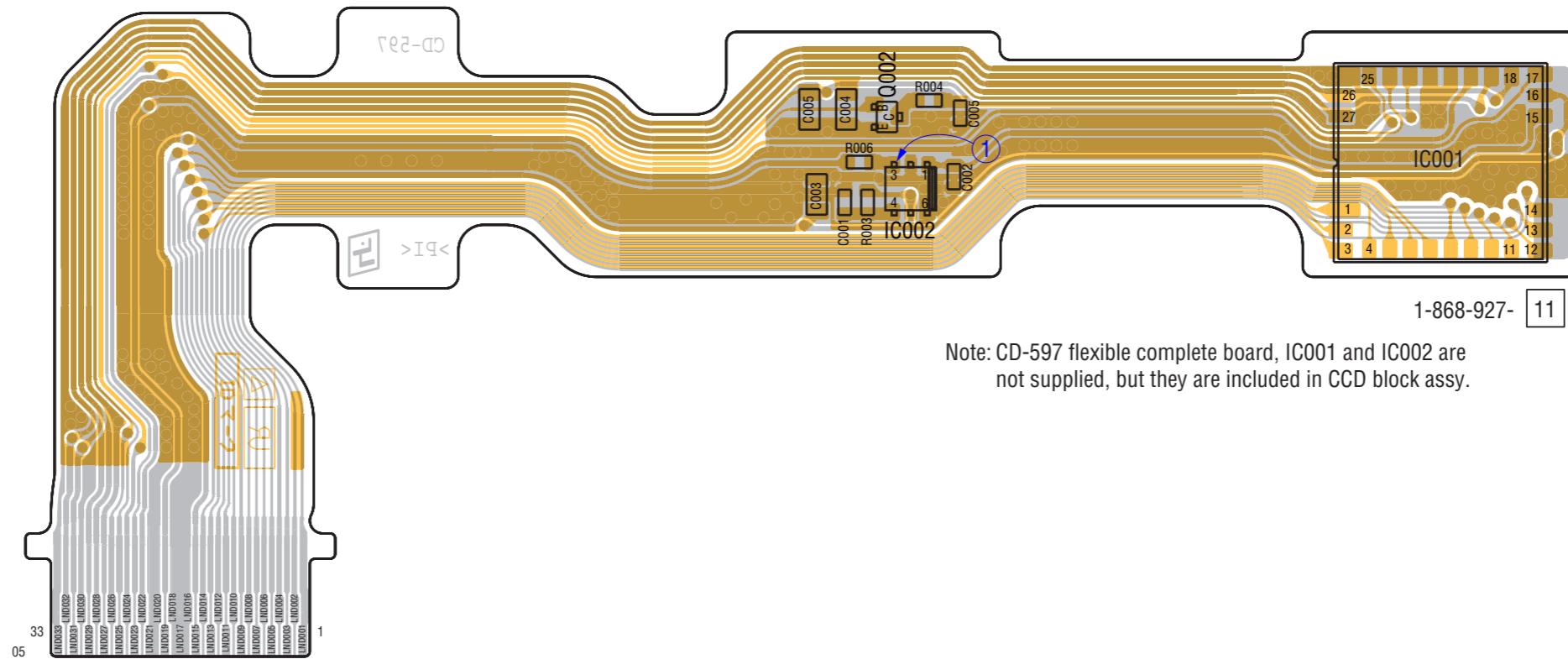

Printed wiring boards of the SY-141 board are not shown.  
Pages from 4-31 to 4-34 are not shown.

 : Uses unleaded solder.

# ST-131 BOARD

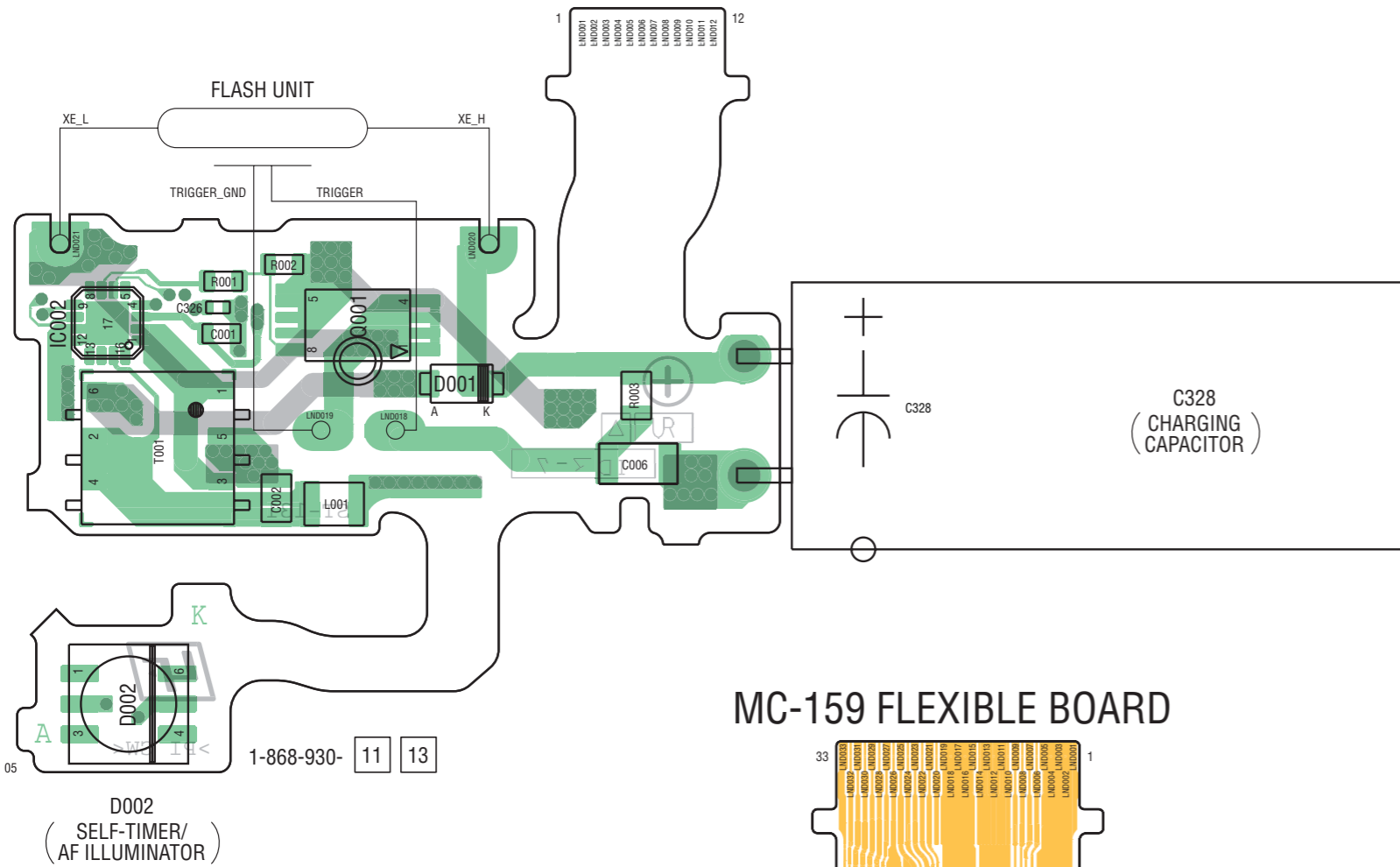

# MC-159 FLEXIBLE BOARD

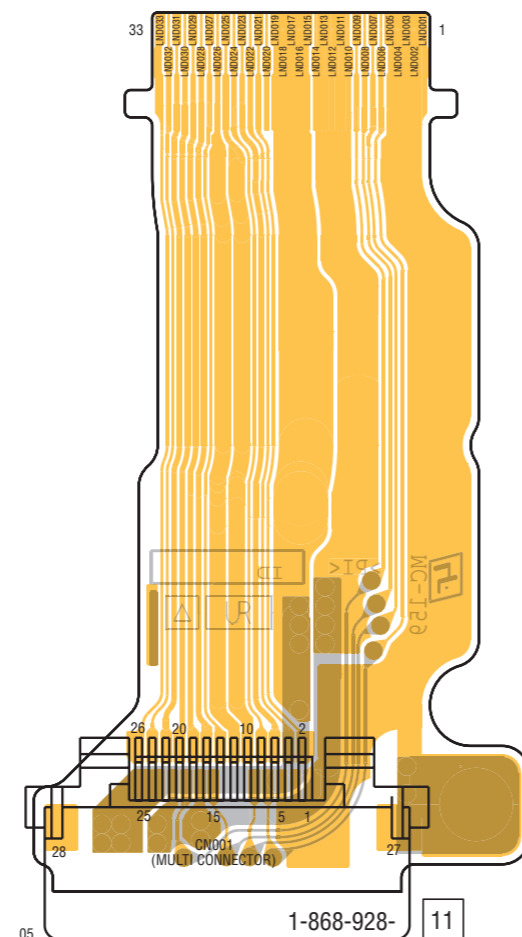

Note: CN001 (multi connector) is not supplied, but this is included in MC-159 flexible complete board.

# BT-029 FLEXIBLE BOARD

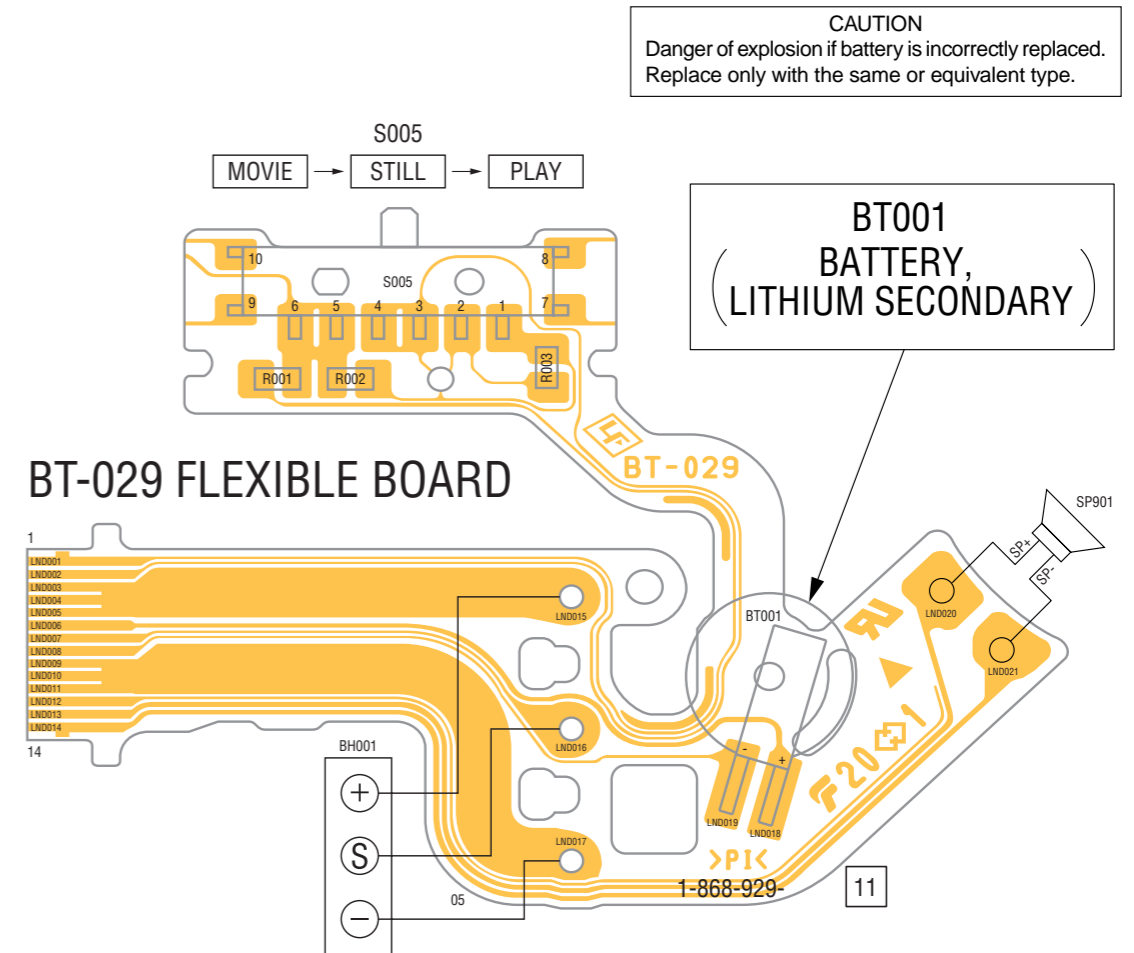

**4-3. PRINTED WIRING BOARDS**

**4-4. WAVEFORMS**

CD-597 FLEXIBLE BOARD

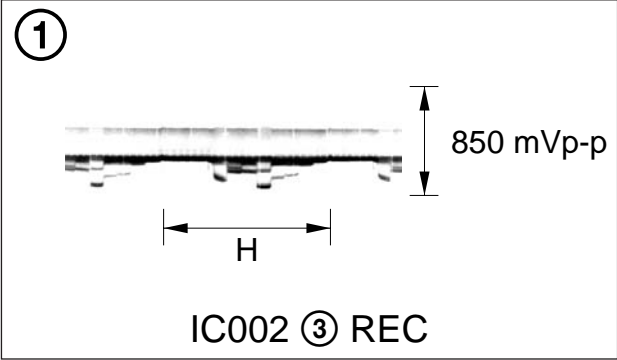

Waveforms of the SY-141 board are not shown.  
Pages 4-38 and 4-39 are not shown.

Mounted parts location of the SY-141 board is not shown.  
Page 4-40 is not shown.

## 5. REPAIR PARTS LIST

NOTE: Characters **A** to **Z** of the electrical parts list indicate location of exploded views in which the desired part is shown.

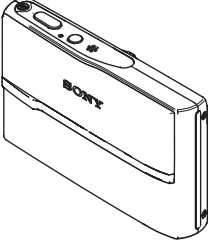
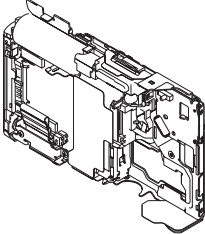
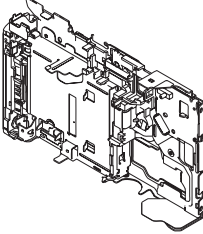
Link	EXPLODED VIEWS		
 <b>A</b>	 <b>B</b>	 <b>C</b>	
OVERALL SECTION	SY BOARD SECTION	FRAME SECTION	

Link	ELECTRICAL PARTS LIST		ACCESSORIES
• BT-029 FLEXIBLE BOARD <b>C</b>	• MC-159 FLEXIBLE BOARD <b>B</b>	• ST-131 BOARD <b>B</b>	
• CD-597 FLEXIBLE BOARD <b>A</b>			

## 5. REPAIR PARTS LIST

### 5. REPAIR PARTS LIST

**NOTE:**

- -XX, -X mean standardized parts, so they may have some differences from the original one.
- Items marked “\*” are not stocked since they are seldom required for routine service. Some delay should be anticipated when ordering these items.
- The mechanical parts with no reference number in the exploded views are not supplied.
- Due to standardization, replacements in the parts list may be different from the parts specified in the diagrams or the components used on the set.
- **CAPACITORS:**  
uF:  $\mu$ F
- **COILS**  
uH:  $\mu$ H
- **RESISTORS**  
All resistors are in ohms.  
METAL: metal-film resistor  
METAL OXIDE: Metal Oxide-film resistor  
F: nonflammable
- **SEMICONDUCTORS**  
In each case, u:  $\mu$ , for example:  
uA...:  $\mu$ A... , uPA... ,  $\mu$ PA... ,  
uPB... ,  $\mu$ PB... ,  $\mu$ PC... ,  $\mu$ PC... ,  
uPD... ,  $\mu$ PD...
- **Abbreviation**  
AR : Argentine model  
AUS : Australian model  
BR : Brazilian model  
CH : Chinese model  
CND : Canadian model  
EE : East European model  
HK : Hong Kong model  
J : Japanese model  
JE : Tourist model  
KR : Korea model  
NE : North European model  
TW : Taiwan model

When indicating parts by reference number, please include the board name.

The components identified by mark  $\triangle$  or dotted line with mark  $\triangle$  are critical for safety. Replace only with part number specified.

Les composants identifiés par une marque  $\triangle$  sont critiques pour la sécurité. Ne les remplacer que par une pièce portant le numéro spécifié.

• **Language that can be selected about SY-141 board**

	Area	Japanese	English	French	German	Spanish	Italian	Portugal	Simplified Chinese	Traditional Chinese	Arabic	Dutch	Russian	Swedish	Korean	Norwegian	Danish	Finnish	Polish	Hungarian	Czech	Persian	Thai	
GP1	J	●																						
GP2	US CND AUS Vietnam		●	●		●	●		●	●														
GP3	AEP UK		●	●	●	●	●	●				●	●	●		●	●	●	●	●	●			
GP4	E AR BR TW JE HK CH KR		●			●		●	●	●	●				●								●	●

# 5. REPAIR PARTS LIST

## 5-1. EXPLODED VIEWS

### 5-1-1. OVERALL SECTION

ns: not supplied

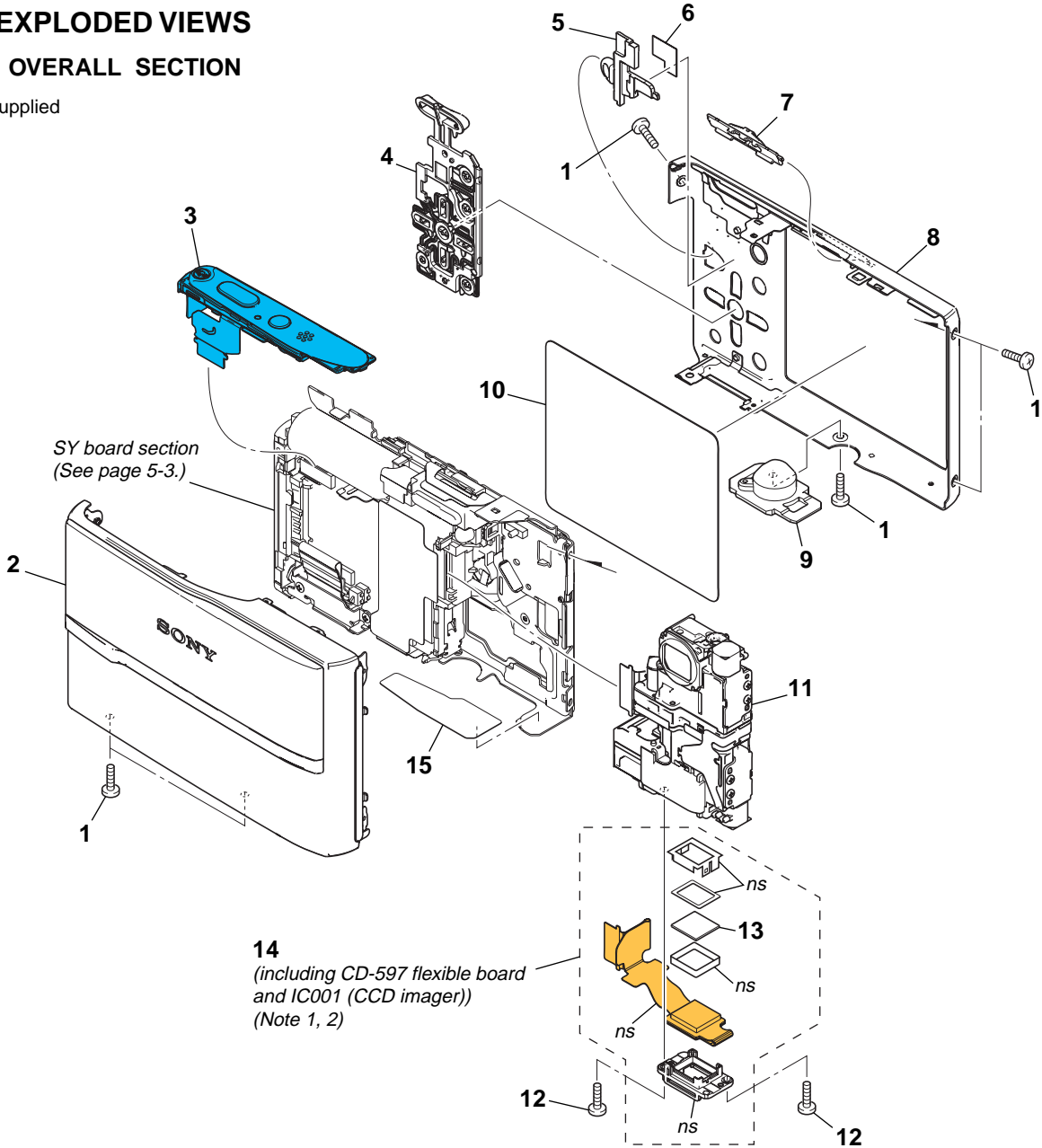

Note 1: CCD block assembly is including CD-597 flexible completed board and IC001 (CCD imager).

Note 2: Be sure to read "Precautions for Replacement of Imager" on page 4-5 when changing the imager.

Ref. No.	Part No.	Description
1	2-635-591-21	SCREW (M1.4), NEW TRUSTAR P2 (SILVER)
1	2-662-396-01	SCREW (M1.4), NEW, TRUSTAR, P2 (BLACK)
2	X-2102-901-1	CABINET (FRONT) ASSY (SILVER)
2	X-2102-902-1	CABINET (FRONT) ASSY (BLACK)
3	1-479-523-11	SWITCH BLOCK, CONTROL (RL51800) (SILVER)
3	1-479-523-21	SWITCH BLOCK, CONTROL (RL51800) (BLACK)
4	2-658-610-01	BUTTON, F
5	2-658-613-01	STRAP
* 6	2-658-620-01	SHEET, F BUTTON ADHESIVE
7	2-658-611-01	KNOB, MODE (SILVER)

Ref. No.	Part No.	Description
7	2-658-611-11	KNOB, MODE (BLACK)
8	X-2102-903-1	CABINET (REAR) ASSY (SILVER)
8	X-2102-904-1	CABINET (REAR) ASSY (BLACK)
9	2-658-612-01	SCREW, TRIPOD
10	2-658-609-01	WINDOW, LCD
11	A-1167-020-A	LSV-1110A (SERVICE USE)
12	3-086-156-11	SCREW B1.2
13	1-788-249-21	OPTICALFILTER BLOCK (OFB-02-22)
14	A-1128-263-A	CCD BLOCK ASSY (including CD-597 flexible board and IC001 (CCD imager)) (Note 1, 2)
15	2-658-616-01	SHEET, CD RADIATION

# 5. REPAIR PARTS LIST

## 5-1-2. SY BOARD SECTION

ns: not supplied

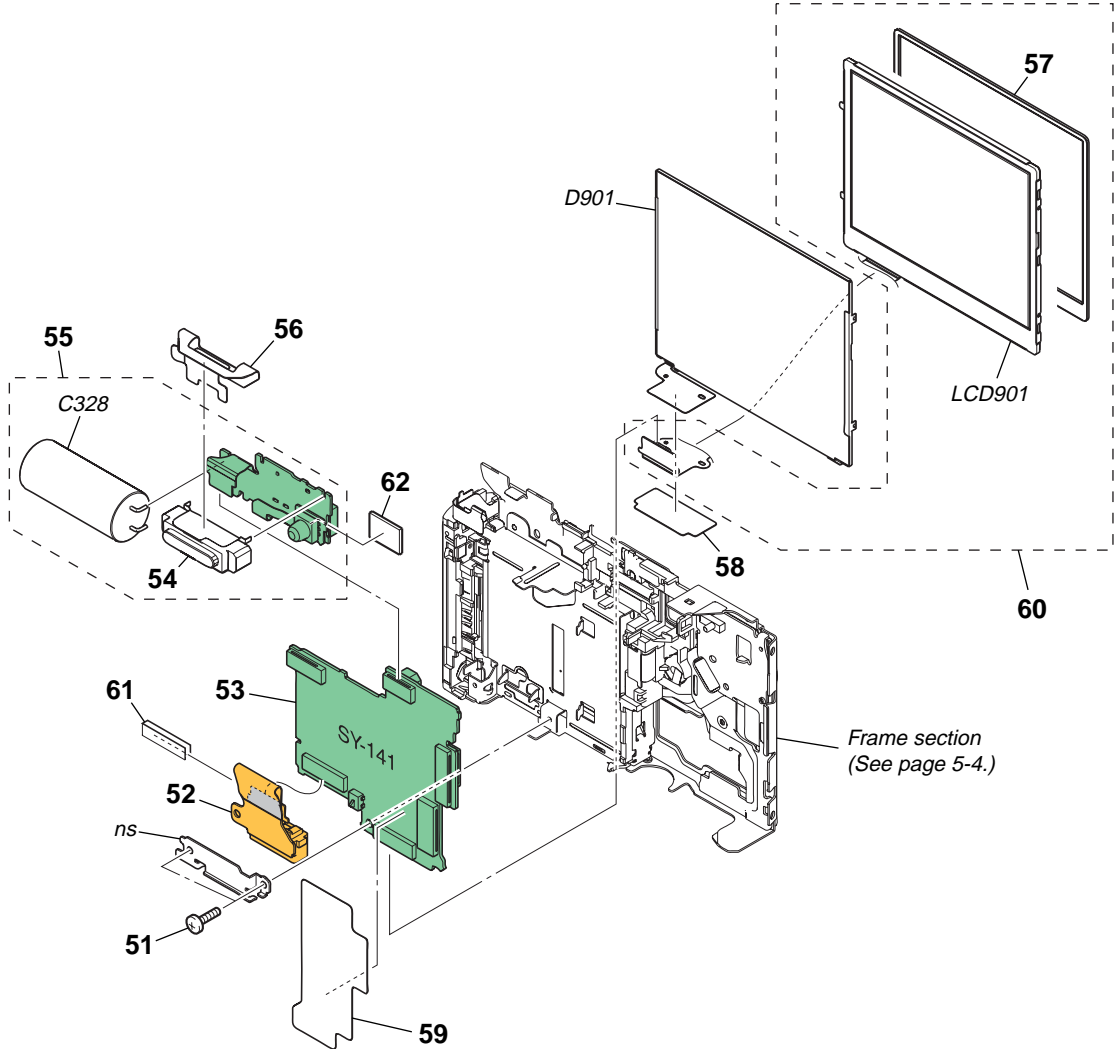

\* Refer to the table of page 5-1 about language of SY-141 board.

• Refer to page 5-1 for mark  $\triangle$ .

Ref. No.	Part No.	Description	Ref. No.	Part No.	Description
51	2-635-591-21	SCREW (M1.4), NEW TRUSTAR P2	57	2-658-621-01	CUSHION, LCD
52	A-1151-831-A	MC-159 FLEXIBLE BOARD, COMPLETE	* 58	2-658-622-01	SHEET, LCD INSULATING
53	A-1168-871-A	SY-141 BOARD, COMPLETE (SERVICE) (GP1)	* 59	2-658-623-01	SHEET, SY INSULATING
53	A-1168-872-A	SY-141 BOARD, COMPLETE (SERVICE) (GP2)	60	A-1166-629-A	SERVICE, LCD BLOCK ASSY
53	A-1168-873-A	SY-141 BOARD, COMPLETE (SERVICE) (GP3)	61	2-664-515-01	SHEET, MC RADIATION
53	A-1168-874-A	SY-141 BOARD, COMPLETE (SERVICE) (GP4)	* 62	2-658-619-01	CUSHION, AF
$\triangle$ 54	1-478-972-11	FLASH UNIT	$\triangle$ * C328	1-100-936-21	ELECT 85uF
$\triangle$ 55	A-1151-830-A	ST-131 BOARD, COMPLETE	D901	1-479-439-11	BLOCK, LIGHT GUIDE PLATE (2.5)
* 56	2-658-617-01	SHEET, ST INSULATING	LCD901	8-753-256-42	ACX542AK-1

## 5. REPAIR PARTS LIST

### 5-1-3. FRAME SECTION

ns: not supplied

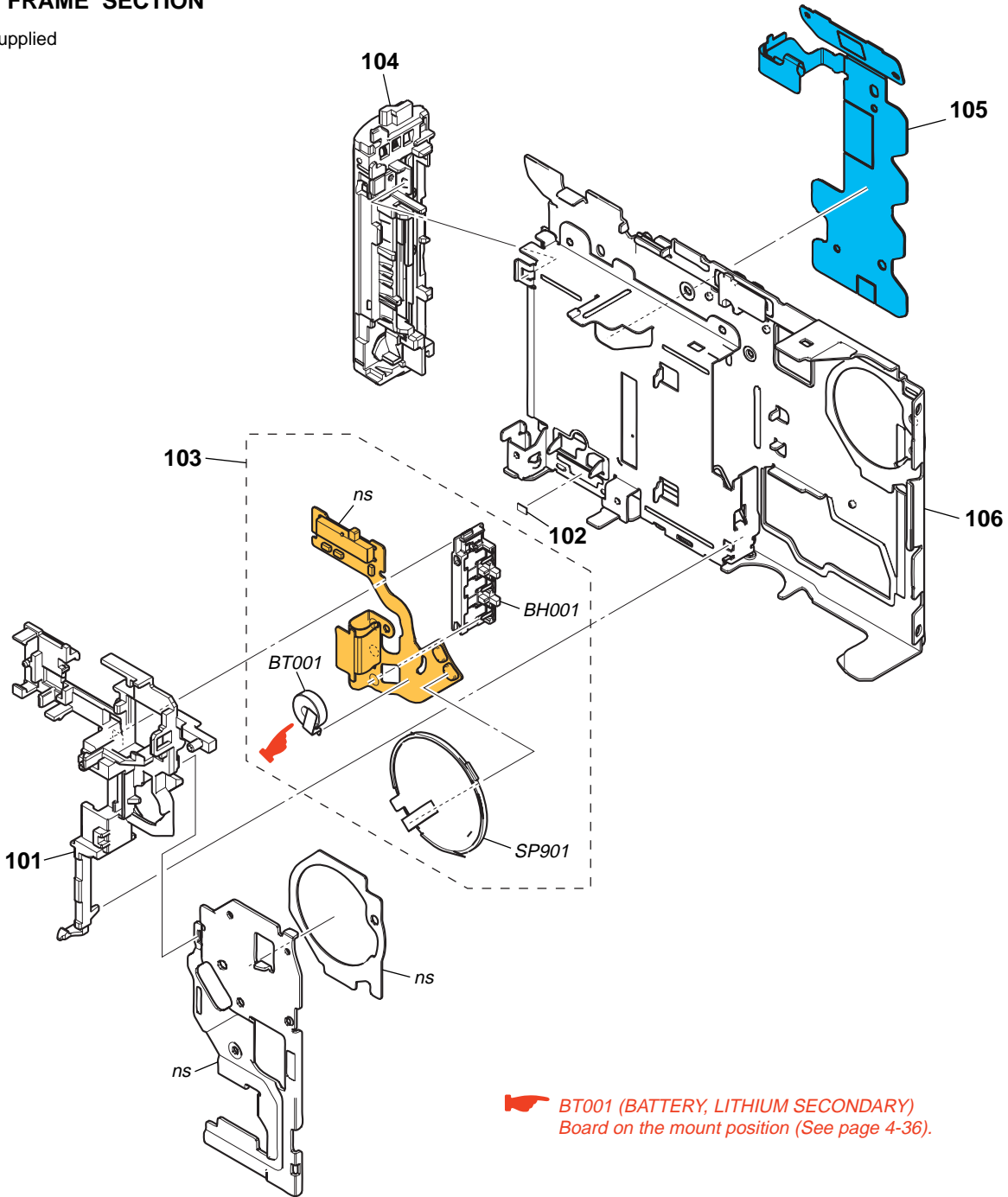

**BT001 (BATTERY, LITHIUM SECONDARY)**  
Board on the mount position (See page 4-36).

**CAUTION**  
Danger of explosion if battery is incorrectly replaced.  
Replace only with the same or equivalent type.

• Refer to page 5-1 for mark △.

Ref. No.	Part No.	Description
* 101	2-658-618-01	HOLDER, TERMINAL
102	2-665-144-01	SHEET, MC CONDUCTIVE
△ 103	A-1153-114-A	BT-029 FLEXIBLE BOARD, COMPLETE
104	X-2102-905-1	BT LID ASSY (SILVER)
104	X-2102-906-1	BT LID ASSY (BLACK)

Ref. No.	Part No.	Description
105	1-479-578-11	SWITCH BLOCK, CONTROL (SW51800)
106	X-2102-896-1	FRAME ASSY
△ BH001	1-780-196-21	TERMINAL BOARD, BATTERY
△* BT001	1-756-566-11	BATTERY, LITHIUM SECONDARY
SP901	1-825-644-21	BUZZER, PIEZOELECTRIC

## 5-2. ELECTRICAL PARTS LIST

Ref. No.	Part No.	Description
△	A-1153-114-A	BT-029 FLEXIBLE BOARD, COMPLETE *****
		< BATTERY TERMINAL >
△ BH001	1-780-196-21	TERMINAL BOARD, BATTERY  < BATTERY >
△* BT001	1-756-566-11	BATTERY, LITHIUM SECONDARY  < SPEAKER >
SP901	1-825-644-21	BUZZER, PIEZOELECTRIC
	A-1128-263-A (Not supplied)	CCD BLOCK ASSY (Note) CD-597 FLEXIBLE BOARD, COMPLETE ***** (CD-597 flexible complete board, IC001 and IC002 are not supplied, but they are included in CCD block assy.)
		< CAPACITOR >
C001	1-164-943-81	CERAMIC CHIP 0.01uF 10% 16V
C003	1-127-715-91	CERAMIC CHIP 0.22uF 10% 16V
C004	1-107-826-11	CERAMIC CHIP 0.1uF 10% 16V
C005	1-107-826-11	CERAMIC CHIP 0.1uF 10% 16V
		< IC >
IC001	(Not supplied)	ICX624EQZ-13 (Note)
IC002	(Not supplied)	IC CXA3691EN-T9
		< TRANSISTOR >
Q002	6-550-119-01	TRANSISTOR DTC144EMT2L
		< RESISTOR >
R003	1-218-981-11	RES-CHIP 220K 5% 1/16W
R004	1-218-990-81	SHORT CHIP 0
R005	1-218-952-11	RES-CHIP 820 5% 1/16W
R006	1-218-990-81	SHORT CHIP 0
	A-1151-831-A	MC-159 FLEXIBLE BOARD, COMPLETE ***** (CN001 (multi connector) is not supplied, but this is included in MC-159 flexible complete board.)
		< CONNECTOR >
CN001	(Not supplied)	CONNECTOR, MULTIPLE (SOCKET)
△	A-1151-830-A	ST-131 BOARD, COMPLETE *****
△	1-478-972-11	FLASH UNIT  < CAPACITOR >
C001	1-165-908-11	CERAMIC CHIP 1uF 10% 10V
C002	1-100-611-91	CERAMIC CHIP 22uF 20% 6.3V
C006	1-100-758-11	CERAMIC CHIP 0.047uF 10% 250V
△* C328	1-100-936-21	ELECT 85uF 315V

• Refer to page 5-1 for mark △.

Ref. No.	Part No.	Description
		< DIODE >
△ D001	6-501-141-01	DIODE FT02P80TP
* D002	6-501-364-01	DIODE DOR5352
		< IC >
IC002	6-707-555-01	IC TPS65552RGTR
		< COIL >
* L001	1-400-820-11	INDUCTOR 2.2uH
		< TRANSISTOR >
△* Q001	6-551-452-01	TRANSISTOR CY25BAJ-8F-T23-G02
		< RESISTOR >
R001	1-216-803-11	METAL CHIP 33 5% 1/10W
R002	1-216-857-11	METAL CHIP 1M 5% 1/10W
R003	1-216-121-11	RES-CHIP 1M 5% 1/10W
		< TRANSFORMER >
△ T001	1-443-880-11	TRANSFORMER, D.C.-D.C. CONVERTER







Electrical parts list of the SY-141 board is not shown.  
Pages 5-6 to 5-9 are not shown.

Note: Be sure to read "Precautions for Replacement of Imager" on page 4-5 when changing the imager.

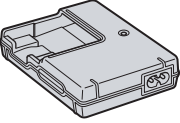
### CAUTION

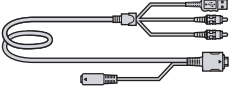
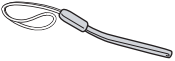
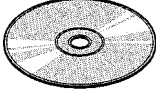
Danger of explosion if battery is incorrectly replaced.  
Replace only with the same or equivalent type.

## Checking supplied accessories.

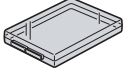
		<b>Other accessories</b>
Battery charger BC-CS3 (1) ▲ 1-479-140-11 (J) ▲ 1-479-140-21 (US, CND) ▲ 1-479-140-31 (EXCEPT US, CND, J)	Power cord (mains lead) (1) ▲ 1-776-985-11 (KR) ▲ 1-782-476-51 (CH) ▲ 1-783-374-11 (UK, HK) ▲ 1-790-732-71 (JE) ▲ 1-823-946-12 (AEP, E) ▲ 1-827-945-11 (AUS)	2-656-791-01 INSTRUCTION (READ THIS FIRST) (JAPANESE) (J) 2-656-791-11 INSTRUCTION (READ THIS FIRST) (ENGLISH) (EXCEPT US, CND, KR, CH, J) 2-656-791-21 INSTRUCTION (READ THIS FIRST) (FRENCH, ITALIAN) (AEP) 2-656-791-31 INSTRUCTION (READ THIS FIRST) (SPANISH, PORTUGUESE) (AEP, E, JE) 2-656-791-41 INSTRUCTION (READ THIS FIRST) (GERMAN, DUTCH) (AEP)
		2-656-791-51 INSTRUCTION (READ THIS FIRST) (TRADITIONAL CHINESE, SIMPLIFIED CHINESE) (E, HK, JE) 2-656-791-61 INSTRUCTION (READ THIS FIRST) (RUSSIAN) (AEP) 2-656-791-71 INSTRUCTION (READ THIS FIRST) (ARABIC, PERSIAN) (E) 2-656-791-81 INSTRUCTION (READ THIS FIRST) (KOREAN) (KR, JE) 2-656-791-91 INSTRUCTION (READ THIS FIRST) (CZECH, POLISH) (AEP)
USB, A/V, DC IN cable for multi-use terminal (1) 1-830-848-11		2-656-799-11 INSTRUCTION (READ THIS FIRST) (HUNGARIAN, SLOVAKIAN) (AEP) 2-656-799-21 INSTRUCTION (READ THIS FIRST) (SWEDISH, FINNISH) (AEP) 2-656-799-31 INSTRUCTION (READ THIS FIRST) (NORWEGIAN, DANISH) (AEP) 2-656-805-11 INSTRUCTION (READ THIS FIRST) (ENGLISH) (US, CND) 2-656-805-21 INSTRUCTION (READ THIS FIRST) (FRENCH, ITALIAN) (CND)
		2-656-807-01 INSTRUCTION (USER'S GUIDE) (JAPANESE) (J) 2-656-807-11 INSTRUCTION (USER'S GUIDE) (ENGLISH) (US, CND, AEP E, HK, AUS, JE) 2-656-807-21 INSTRUCTION (USER'S GUIDE) (FRENCH, ITALIAN) (CND, AEP) 2-656-807-31 INSTRUCTION (USER'S GUIDE) (SPANISH, PORTUGUESE) (AEP) 2-656-807-41 INSTRUCTION (USER'S GUIDE) (GERMAN, DUTCH) (AEP)
Wrist strap (1) 2-050-981-01 (SILVER) 2-050-981-11 (BLACK)	CD-ROM (Cyber-shot application software) (1) 2-655-049-01	2-656-807-51 INSTRUCTION (USER'S GUIDE) (TRADITIONAL CHINESE, SIMPLIFIED CHINESE) (E, HK, JE) 2-656-807-61 INSTRUCTION (USER'S GUIDE) (RUSSIAN) (AEP) 2-656-807-71 INSTRUCTION (USER'S GUIDE) (ARABIC, PERSIAN) (E) 2-656-807-81 INSTRUCTION (USER'S GUIDE) (KOREAN) (KR, JE) 2-656-807-91 INSTRUCTION (USER'S GUIDE) (CZECH, POLISH) (AEP)
		2-656-817-11 INSTRUCTION (USER'S GUIDE) (HUNGARIAN, SLOVAKIAN) (AEP) 2-656-817-21 INSTRUCTION (USER'S GUIDE) (SWEDISH, FINNISH) (AEP) 2-656-817-31 INSTRUCTION (USER'S GUIDE) (NORWEGIAN, DANISH) (AEP)
Conversion adaptor (1) ▲ 1-569-008-21 (E)	Conversion adaptor (1) ▲ 1-569-007-12 (JE)	
		
Rechargeable battery pack NP-FT1 (1) (not supplied)	Battery case (1) (not supplied)	

• Refer to page 5-1 for mark ▲.

**[Description of main button functions on toolbar of the Adobe Acrobat Reader Ver5.0 (for Windows)]**

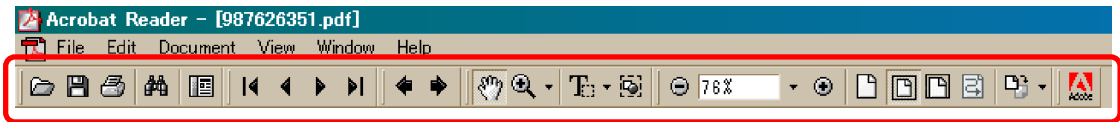

Toolbar



**Printing a text**

1. Click the Print button .
2. Specify a printer, print range, number of copies, and other options, and then click [OK].

**Application of printing:**

To set a range to be printed within a page, select the graphic selection tool  and drag on the page to enclose a range to be printed, and then click the Print button.

**Reversing the screens displayed once**

- To reverse the previous screens (operation) one by one, click the .
- To advance the reversed screens (operation) one by one, click the .

**Application to the Service Manual:**

This function allows you to go and back between circuit diagram and printed circuit board diagram, and accordingly it will be convenient for the voltage check.

**Finding a text**

1. Click the Find button .
2. Enter a character string to be found into a text box, and click the [Find]. (Specify the find options as necessary)

**Application to the Service Manual:**

To execute “find” from current page toward the previous pages, select the check box “Find Backward” and then click the “Find”.

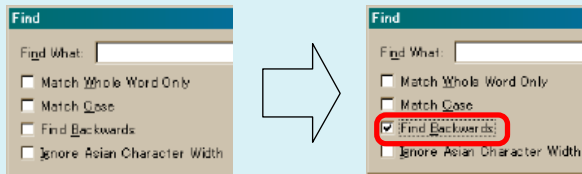





3. Open the find dialog box again, and click the [Find Again] and you can find the matched character strings displayed next. (Character strings entered previously are displayed as they are in the text box.)

**Application to the Service Manual:**

The parts on the drawing pages (block diagrams, circuit diagrams, printed circuit boards) and parts list pages in a text can be found using this find function. For example, find a Ref. No. of IC on the block diagram, and click the [Find Again] continuously, so that you can move to the Ref. No. of IC on the circuit diagram or printed circuit board diagram successively.

**Note:** The find function may not be applied to the Service Manual depending on the date of issue.

**Moving with link**

1. Select either palm tool , zoom tool , text selection tool , or graphic selection tool .
2. Place the pointer in the position in a text where the link exists (such as a button on cover and the table of contents page, or blue characters on the removal flowchart page or drawing page), and the pointer will change to the forefinger form .
3. Then, click the link. (You will go to the link destination.)

**Moving with bookmark:**

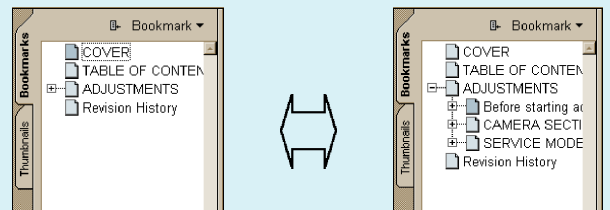

Click an item (text) on the bookmark pallet. and you can move to the link destination. Also, clicking  can display the hidden items.

(To go back to original state, click )



**Zooming or rotating the screen display**

**“Zoom in/out”**

- Click the triangle button in the zoom control box to select the display magnification. Or, you may click  or  for zooming in or out.

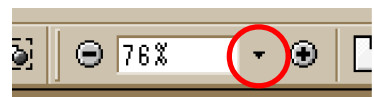





**“Rotate”**

- Click rotate tool , and the page then rotates 90 degrees each.

**Application to the Service Manual:**

The printed circuit board diagram you see now can be changed to the same direction as the set.

**Switching a page**

- To move to the first page, click the .
- To move to the last page, click the .
- To move to the previous page, click the .
- To move to the next page, click the .

# DSC-T9

SONY®

LEVEL 2

## SERVICE MANUAL

Ver 1.1 2005.12

*US Model  
Canadian Model  
AEP Model  
UK Model  
E Model  
Australian Model  
Hong Kong Model  
Chinese Model  
Korea Model  
Brazilian Model  
Japanese Model  
Tourist Model*

## SUPPLEMENT-1

File this supplement with the service manual.  
(PV05-072)

- Addition of Brazilian Model
- Changing of Repair Parts

### • Changing of Repair Parts

: Points changed portion.

#### 5-1. EXPLODED VIEWS

##### 5-1-1. OVERALL SECTION

(See original service manual page 5-2)

Former			New		
Ref. No.	Part No.	Description	Ref. No.	Part No.	Description
15	2-658-616-01	SHEET, CD RADIATION	 15	2-658-616-01	SHEET, CD RADIATION

: Points changed portion.

**5-1-2. SY BOARD SECTION**

(See original service manual page 5-3)

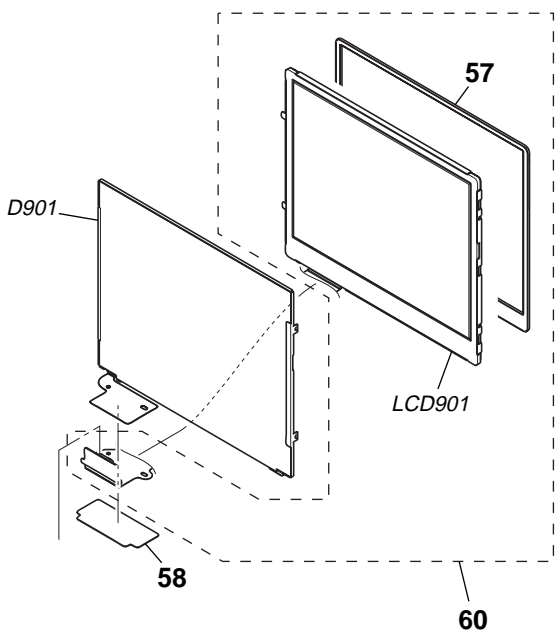
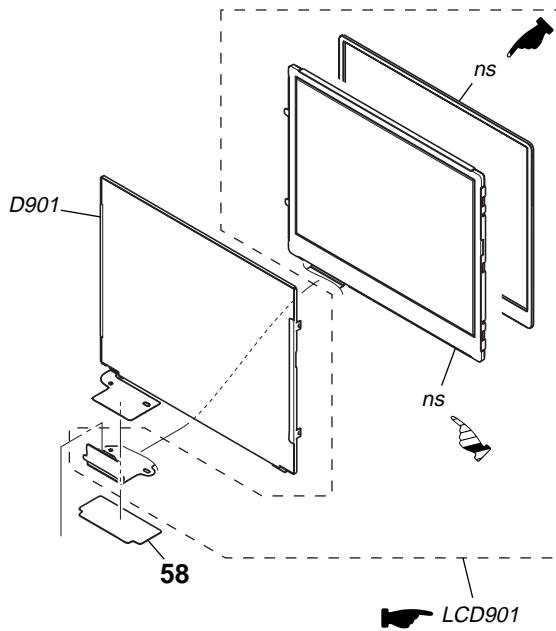
Former			New		
					
Ref. No.	Part No.	Description	Ref. No.	Part No.	Description
57	2-658-621-01	CUSHION, LCD			
60	A-1166-629-A	SERVICE, LCD BLOCK ASSY			
LCD901	8-753-256-42	ACX542AK-1	LCD901	A-1166-629-A	SERVICE, LCD BLOCK ASSY

**• Addition of Brazilian Model**

Checking supplied accessories.

: Points add portion.

(See original service manual page 5-10E)

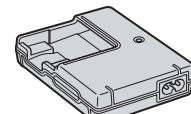
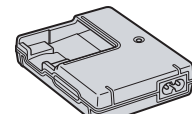
Former	New
 <p>Battery charger BC-CS3 (1)            ▲ 1-479-140-11 (J)            ▲ 1-479-140-21 (US, CND)            ▲ 1-479-140-31 (EXCEPT US, CND, J)</p>	 <p>Battery charger BC-CS3 (1)            ▲ 1-479-140-11 (J)            ▲ 1-479-140-21 (US, CND)            ▲ 1-479-140-31 (EXCEPT US, CND, <u>BR</u>, J)</p>

