

# DSC-T77

## SERVICE MANUAL

LEVEL 2

Ver. 1.0 2008.08

Revision History

Internal memory  
ON BOARD



Photo: Black

US Model  
Canadian Model  
AEP Model  
UK Model  
E Model  
Australian Model  
Hong Kong Model  
Chinese Model  
Korea Model  
Argentine Model  
Thai Model  
Japanese Model  
Tourist Model

### Link

<a href="#">SPECIFICATIONS</a>	<a href="#">BLOCK DIAGRAMS</a>	<a href="#">PRINTED WIRING BOARDS</a>
<a href="#">SERVICE NOTE</a>	<a href="#">FRAME SCHEMATIC DIAGRAM</a>	<a href="#">REPAIR PARTS LIST</a>
<a href="#">DISASSEMBLY</a>	<a href="#">SCHEMATIC DIAGRAMS</a>	

#### • Precaution on Replacing the SY-207 Board

The components identified by mark  $\triangle$  or dotted line with mark  $\triangle$  are critical for safety. Replace only with part number specified.

Les composants identifiés par une marque  $\triangle$  sont critiques pour la sécurité. Ne les remplacer que par une pièce portant le numéro spécifié.

DIGITAL STILL CAMERA

**SONY**<sup>®</sup>



Cyber-shot



## SPECIFICATIONS

### Camera

#### [System]

Image device: 7.7 mm (1/2.3 type) color CCD,  
Primary color filter  
Total pixel number of camera: Approx. 10.3  
Megapixels  
Effective pixel number of camera: Approx. 10.1  
Megapixels  
Lens: Carl Zeiss Vario-Tessar 4× zoom lens  
f = 6.18 – 24.7 mm (35 – 140 mm (35 mm  
film equivalent))  
F3.5 (W) – F4.6 (T)  
Exposure control: Automatic exposure, Scene  
Selection (11 modes)  
White balance: Automatic, Daylight, Cloudy,  
Fluorescent 1,2,3, Incandescent, Flash  
Underwater White Balance: Auto, Underwater  
1,2, Flash  
File format (DCF compliant):  
Still images: Exif Ver. 2.21 JPEG compliant,  
DPOF compatible  
Movies: MPEG1 compliant (Monaural)  
Recording media: Internal Memory  
(approx. 15 MB), “Memory Stick Duo”  
Flash: Flash range (ISO sensitivity  
(Recommended exposure Index) set to Auto):  
Approx. 0.08 to 3.0 m (3 1/4 inches to  
9 feet 10 1/8 inches) (W/  
approx. 0.5 to 2.4 m (1 feet 7 3/4 inches to  
7 feet 10 1/2 inches) (T)

#### [Input and Output connectors]

Multi connector: Video output  
Audio output (Monaural)  
USB communication  
USB communication: Hi-Speed USB (USB 2.0  
compliant)

#### [LCD screen]

LCD panel: Wide (16:9), 7.5 cm (3.0 type) TFT  
drive  
Total number of dots: 230 400 (960 × 240) dots

#### [Power, general]

Power: Rechargeable battery pack NP-BD1, 3.6 V  
NP-FD1 (not supplied), 3.6 V  
AC-LS5K AC Adaptor (not supplied), 4.2 V  
Power consumption (during shooting): 1.1 W  
Operating temperature: 0 to 40°C (32 to 104°F)  
Storage temperature: -20 to +60°C (-4 to +140°F)  
Dimensions: 93.6 × 57.2 × 15.0 mm (3 3/4 × 2 3/8  
× 19/32 inches) (W/H/D, excluding  
protrusions)  
Mass (including NP-BD1 battery pack, paint pen  
and strap etc.): Approx. 151 g (5.3 oz)  
Microphone: Monaural  
Speaker: Monaural  
Exif Print: Compatible  
PRINT Image Matching III: Compatible  
PictBridge: Compatible

#### BC-CSD battery charger

Power requirements: AC 100 V to 240 V,  
50/60 Hz, 2.2 W  
Output voltage: DC 4.2 V, 0.33 A  
Operating temperature: 0 to 40°C (32 to 104°F)  
Storage temperature: -20 to +60°C (-4 to +140°F)  
Dimensions: Approx. 62 × 24 × 91 mm (2 1/2 ×  
3 1/32 × 3 5/8 inches) (W/H/D)  
Mass: Approx. 75 g (2.7 oz)

#### Rechargeable battery pack NP-BD1

Used battery: Lithium-ion battery  
Maximum voltage: DC 4.2 V  
Nominal voltage: DC 3.6 V  
Capacity: 2.4 Wh (680 mAh)

Design and specifications are subject to  
change without notice.

**CAUTION**

Danger of explosion if battery is incorrectly replaced.  
Replace only with the same or equivalent type.

**SAFETY-RELATED COMPONENT WARNING!!**

**COMPONENTS IDENTIFIED BY MARK  $\triangle$  OR DOTTED LINE WITH MARK  $\triangle$  ON THE SCHEMATIC DIAGRAMS AND IN THE PARTS LIST ARE CRITICAL TO SAFE OPERATION. REPLACE THESE COMPONENTS WITH SONY PARTS WHOSE PART NUMBERS APPEAR AS SHOWN IN THIS MANUAL OR IN SUPPLEMENTS PUBLISHED BY SONY.**

**ATTENTION AU COMPOSANT AYANT RAPPORT  
À LA SÉCURITÉ!**

**LES COMPOSANTS IDENTIFÉS PAR UNE MARQUE  $\triangle$  SUR LES DIAGRAMMES SCHÉMATIQUES ET LA LISTE DES PIÈCES SONT CRITIQUES POUR LA SÉCURITÉ DE FONCTIONNEMENT. NE REMPLACER CES COMPOSANTS QUE PAR DES PIÈSES SONY DONT LES NUMÉROS SONT DONNÉS DANS CE MANUEL OU DANS LES SUPPLÉMENTS PUBLIÉS PAR SONY.**

## SAFETY CHECK-OUT

After correcting the original service problem, perform the following safety checks before releasing the set to the customer.

1. Check the area of your repair for unsoldered or poorly-soldered connections. Check the entire board surface for solder splashes and bridges.
2. Check the interboard wiring to ensure that no wires are "pinched" or contact high-wattage resistors.
3. Look for unauthorized replacement parts, particularly transistors, that were installed during a previous repair. Point them out to the customer and recommend their replacement.
4. Look for parts which, through functioning, show obvious signs of deterioration. Point them out to the customer and recommend their replacement.
5. Check the B+ voltage to see it is at the values specified.
6. Flexible Circuit Board Repairing
  - Keep the temperature of the soldering iron around 270°C during repairing.
  - Do not touch the soldering iron on the same conductor of the circuit board (within 3 times).
  - Be careful not to apply force on the conductor when soldering or unsoldering.

### Unleaded solder

Boards requiring use of unleaded solder are printed with the lead-free mark (LF) indicating the solder contains no lead.

(Caution: Some printed circuit boards may not come printed with the lead free mark due to their particular size.)

### : LEAD FREE MARK

Unleaded solder has the following characteristics.

- Unleaded solder melts at a temperature about 40°C higher than ordinary solder.  
Ordinary soldering irons can be used but the iron tip has to be applied to the solder joint for a slightly longer time.  
Soldering irons using a temperature regulator should be set to about 350°C.  
Caution: The printed pattern (copper foil) may peel away if the heated tip is applied for too long, so be careful!
- Strong viscosity  
Unleaded solder is more viscous (sticky, less prone to flow) than ordinary solder so use caution not to let solder bridges occur such as on IC pins, etc.
- Usable with ordinary solder  
It is best to use only unleaded solder but unleaded solder may also be added to ordinary solder.

## 1-1. PRECAUTION ON REPLACING THE SY-207 BOARD

### DESTINATION DATA

When you replace to the repairing board, the written destination data of repairing board also might be changed to original setting. Refer to Service Manual ADJ, and perform "DESTINATION DATA WRITE".

### USB SERIAL No.

The set is shipped with a unique ID (USB Serial No.) written in it.

This ID has not been written in a new board for service, and therefore it must be entered after the board replacement.

Refer to Service Manual ADJ, and perform "USB SERIAL No. INPUT".

### Angular Velocity Sensor

When you replace to the repairing board, write down the sensitivity displayed on the angular velocity sensor (SE510).

Refer to Service Manual ADJ, and perform "Angular velocity sensor sensitivity adj".

#### SY-207 BOARD (SIDE B)

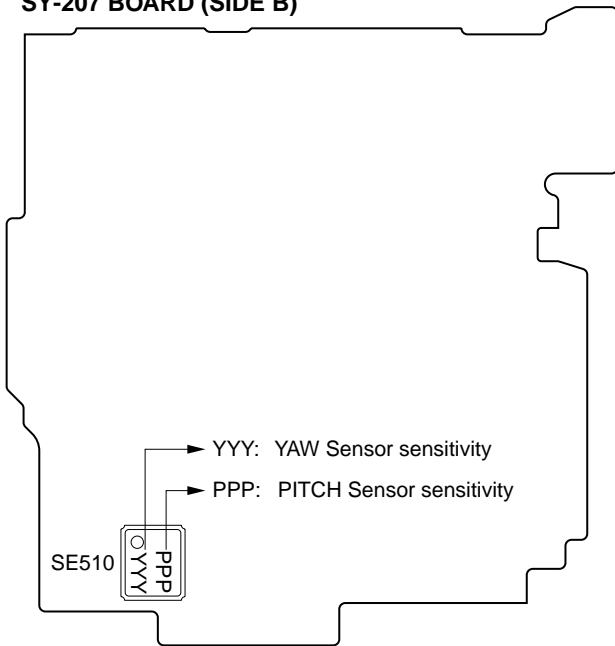

**Note:** The sensor sensitivity of SE510 of SY-207 board is written only repair parts.

## 1-2. PRECAUTION ON REPLACING THE LENS

When replacing the lens, write down the PITCH/YAW data, FN data and wide limit data given on the data sheet of the replacement lens for service.

Refer to Service Manual ADJ, and perform "Wide Limit adj" and "Angular velocity sensor sensitivity adj".

Wide Limit Data (2-byte data)

XXYY

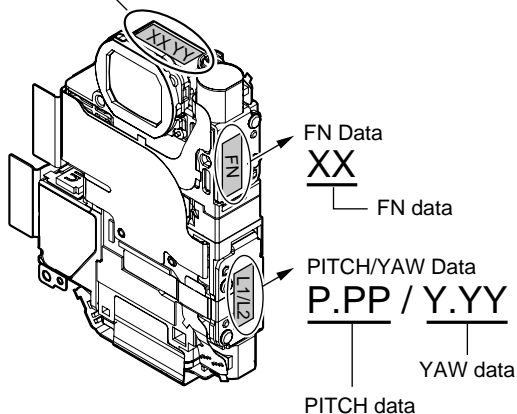

**Note:** The PITCH/YAW data, FN data and wide limit data of lens are written only repair parts.

## 1-3. METHOD FOR COPYING OR ERASING THE DATA IN INTERNAL MEMORY

The data can be copied/erased by the operations on the HOME screen. (When erasing the data, execute formatting the internal memory.)

**Note 1:** When replacing the SY-207 board, erase the data in internal memory of the board before replacement.

**Note 2:** When replacing the SY-207 board, execute formatting and initialize the internal memory after replacement.

### Method for Copying the Data in Internal Memory

#### Copy

Copies all images in the internal memory to a "Memory Stick Duo".

- 1 Insert a "Memory Stick Duo" into the camera.
- 2 **HOME** → **▼** (Manage Memory) → [Memory Tool] → **OK** → [Copy] → **OK** → [OK]



#### Notes

- Use a fully charged battery pack. If you attempt to copy image files using a battery pack with little remaining charge, the battery pack may run out, causing copying to fail or possibly corrupting the data.
- You cannot select images to copy.
- The original images in the internal memory are retained even after copying. To delete the contents of the internal memory, remove the "Memory Stick Duo" after copying, then format the internal memory ([Format] in [Memory Tool]).
- A new folder is created on the "Memory Stick Duo" and all the data will be copied to it. You cannot choose a specific folder and copy images to it.

### Method for Formatting the Internal Memory

#### Format

Formats the "Memory Stick Duo" or the internal memory. A commercially available "Memory Stick Duo" is already formatted, and can be used immediately.

- 1 **HOME** → **▼** (Manage Memory) → [Memory Tool] → **OK** → [Format] → **OK** → [OK]

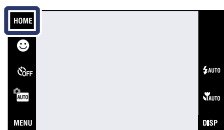

#### Notes

- Note that formatting permanently erases all data including even protected images.

## 1-4. HOW TO WRITE DATA TO INTERNAL MEMORY

Usually, the camera has been set so as to disable the data writing from the PC to the internal memory of the camera.

This setting must be changed temporarily when the data is to be written to the internal memory such as a case after the board replacement. To change the setting, use the write enable tool "WriteEnableTool.exe".

### Data writing method

- 1) Connect the PC to the camera (USB mode: Mass Storage), and switch the driver to the "Sony Seus USB Driver".
- 2) Start the Write Enable Tool and the SeusEX.
- 3) Click the **Activate Write Enable Mode** button of the Write Enable Tool.

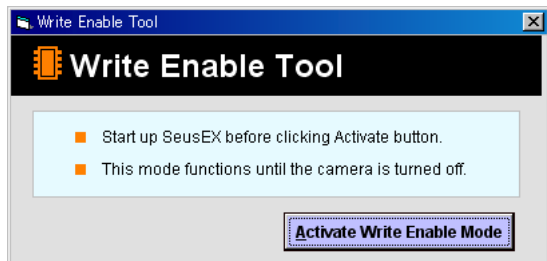

- 4) Upon completion of the setting change, the following message will be displayed.

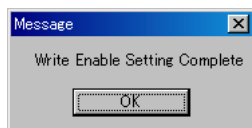

- 5) Return the driver to the original one, and connect the PC to the camera (USB mode: Mass Storage).
- 6) Write the data read out into the PC to the internal memory of the camera.
- 7) Disconnect the PC from the camera, and turn off the camera.

**Note:** By turning off the camera, the write enable setting is reset.

## 1-5. SELF-DIAGNOSIS FUNCTION

### 1-5-1. Self-diagnosis Function

When problems occur while the unit is operating, the self-diagnosis function starts working, and displays on the LCD screen what to do.

Details of the self-diagnosis functions are provided in the Instruction manual.

### 1-5-2. Self-diagnosis Display

When problems occur while the unit is operating, the LCD screen shows a 4-digit display consisting of an alphabet and numbers, which blinks at 3.2 Hz. This 5-character display indicates the “repaired by:”, “block” in which the problem occurred, and “detailed code” of the problem.

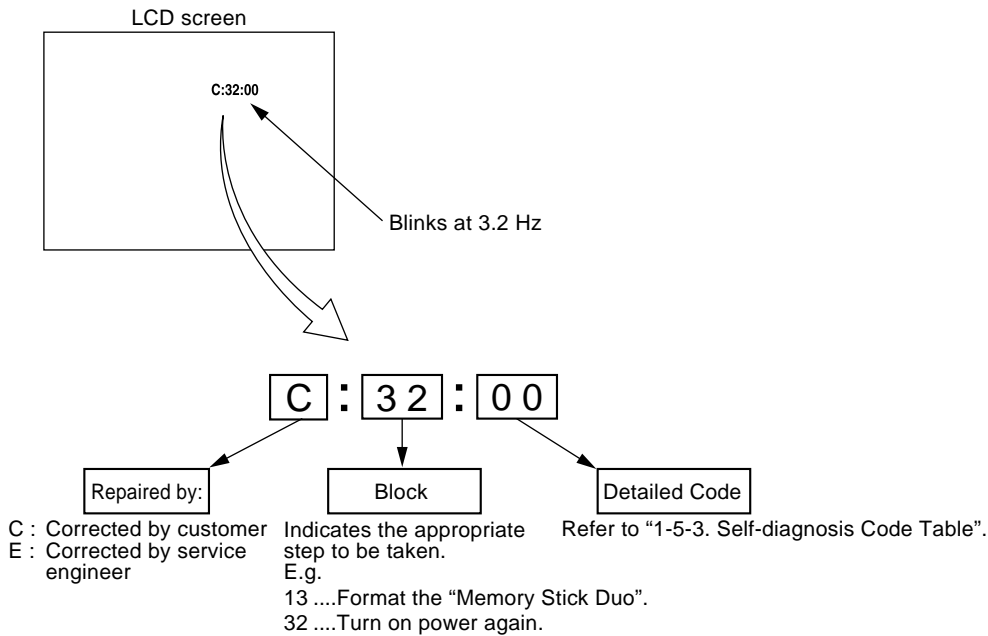

## 1-5-3. Self-diagnosis Code Table

Self-diagnosis Code				Symptom/State	Correction
Repaired by:	Block Function	Detailed Code			
C	1 3	0 1	1	The internal memory has experienced a media error.	Turn the power off and on again.
				The internal memory has experienced a format error.	Format the internal memory.
				“Memory Stick Duo” is unformatted.	Format the “Memory Stick Duo”.
				“Memory Stick Duo” is broken.	Insert a new “Memory Stick Duo”.
				“Memory Stick Duo” type error	Insert a supported “Memory Stick Duo”.
				The camera cannot read or write data on the “Memory Stick Duo”.	Turn the power off and on again, or taking out and inserting the “Memory Stick Duo” several times.
C	3 2	0 1	1	Trouble with hardware	Turn the power off and on again.
E	6 1	0 0	0	Difficult to adjust focus (Cannot initialize focus)	Retry turn the power on by the power switch. If it does not recover, check the focus reset sensor of lens block (pin ⑳ of CN501 on the SY-207 board). If it is OK, check the focus motor drive IC (IC503 on the SY-207 board).
E	6 1	1 0	1	Zoom operations fault (Cannot initialize zoom lens.)	Retry turn the power on by the power switch. Check the zoom reset sensor of lens block (pin ㉑ of CN501 on the SY-207 board), if zooming is performed when the zoom button is operated. If it is OK, check the zoom motor drive IC (IC503 on the SY-207 board).
E	6 2	0 2	0	Abnormality of IC for steadyspot.	Check or replacement of the IC for steadyspot (IC503 on the SY-207 board).
E	6 2	1 0	1	Lens initializing failure.	Check or replacement of the IC for steadyspot (IC503 on the SY-207 board).
E	6 2	1 1	1	Lens overheating (PITCH).	Check the HALL element (PITCH) of optical image stabilizer (pin ⑩, ⑪ of CN501 on the SY-207 board). If it is OK, check PITCH/YAW angular velocity sensor (SE510 on the SY-207 board) peripheral circuits.
E	6 2	1 2	1	Lens overheating (YAW).	Check the HALL element (YAW) of optical image stabilizer (pin ⑦, ⑫ of CN501 on the SY-207 board). If it is OK, check PITCH/YAW angular velocity sensor (SE510 on the SY-207 board) peripheral circuits.
E	6 2	2 0	2	Abnormality of thermistor.	Check the OIS temp sensor of optical image stabilizer (pin ⑬ of CN501 on the SY-207 board).
E	9 1	0 1	0	Abnormality when flash is being charged.	Checking of flash unit or replacement of flash unit. (Note)
E	9 2	0 0	0	Non-standard battery is used.	Use the compatible battery only.

**Note:** After repair, be sure to perform “1-6. PROCESS AFTER FIXING FLASH ERROR”.

## 1-6. PROCESS AFTER FIXING FLASH ERROR

When “FLASH error” (Self-diagnosis Code E : 91 : 01) occurs, to prevent any abnormal situation caused by high voltage, setting of the flash is changed automatically to disabling charge and flash setting.

After fixing, this setting needs to be deactivated. Flash error code can be initialized by the operations on the HOME screen.

### Method for Initializing the Flash Error Code

#### Initialize

Initializes the setting to the default setting.

Even if you execute this function, the images are retained.

- 1 **HOME** →  (Settings) → [Main Settings] → **OK** → [Initialize] → **OK** → [OK]



#### Notes

- Be sure not to turn off the camera while initializing.

## 1-1. SY-207基板交換時の注意

### 仕向けデータ

補修用基板と交換する時、補修用基板に書かれている仕向けデータは元の設定と違う場合があります。  
ADJ編を参照して、「DESTINATION DATA WRITE」を行ってください。

### USBシリアルNo.

セットは、1台毎に異なる固有のID (USB Serial No.) を書き込んだ後、出荷されています。  
新品の補修用基板には、このIDが書き込まれていないので、基板交換後にIDを入力する必要があります。  
ADJ編を参照して、「USB SERIAL No. INPUT」を行ってください。

### 角速度センサ

補修用基板と交換する時、角速度センサ (SE510) の感度表示を書き留めてください。  
ADJ編を参照して、「角速度センサ感度調整」を行ってください。

#### SY-207 BOARD (SIDE B)

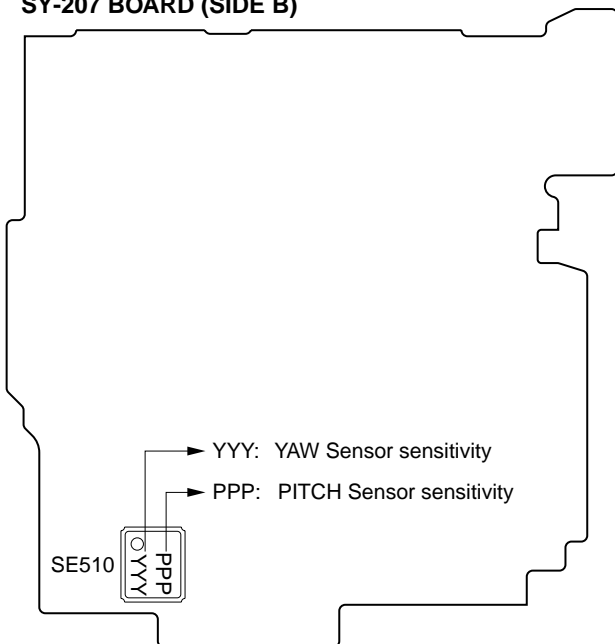

Note : SY-207基板のSE510感度表示は補修用基板にしか記載されておりません。

## 1-2. レンズ交換時の注意

レンズ交換時、補修用レンズ添付データシート掲載のPITCH/YAWデータ、FNデータおよびW端調整データを書き留めてください。  
ADJ編を参照して、「W端調整」、「角速度センサ感度調整」を行ってください。

Wide Limit Data (2-byte data)

XXYY

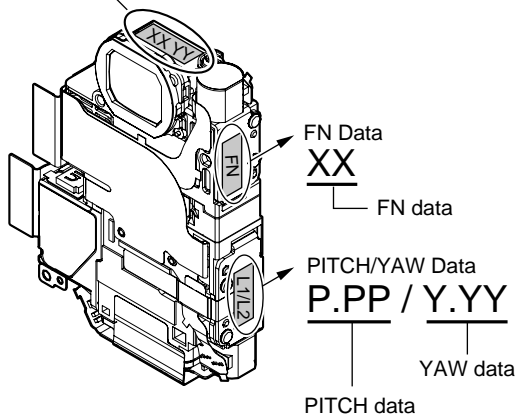

Note : PITCH/YAWデータ、FNデータおよびW端調整データは、補修用部品にのみ記載されています。

### 1-3. 内蔵メモリーのデータコピーおよび消去方法

内蔵メモリーのデータコピーまたは消去はホーム画面の操作から実行可能です。（消去する場合は内蔵メモリーの初期化を行います。）

Note1：SY-207基板交換の際は、基板交換前に内蔵メモリーのデータを消去して下さい。

Note2：SY-207基板交換の際は、基板交換後に内蔵メモリーのフォーマットおよび初期化を実行して下さい。

#### 内蔵メモリーのコピー方法

##### コピー

内蔵メモリーに記録した画像を、“メモリースティック デュオ”に一括コピーします。

- 1 “メモリースティック デュオ”を本機に入れる
- 2 HOME → (メモリー管理) → [メモリーツール] → OK → [コピー] → OK → [実行]



##### ご注意

- 十分に充電したバッテリーをご使用ください。残量の少ないバッテリーを使用して画像ファイルのコピーすると、バッテリー切れのためデータを転送できなかったり、データを破損するおそれがあります。
- 画像ごとのコピーはできません。
- データをコピーしても、内蔵メモリー内のデータは削除されません。内蔵メモリーの内容を消去するには、コピー後に“メモリースティック デュオ”を本体から取りはずし、[メモリーツール]の[フォーマット]を行ってください。
- データをコピーすると“メモリースティック デュオ”内に新しいフォルダが作成されます。コピー先のフォルダを指定することはできません。

#### 内蔵メモリーのフォーマット方法

##### フォーマット

“メモリースティック デュオ”または内蔵メモリーをフォーマット（初期化）します。市販の“メモリースティック デュオ”はフォーマット済みのため、フォーマットの必要はありません。

- 1 HOME → (メモリー管理) → [メモリーツール] → OK → [フォーマット] → OK → [実行]

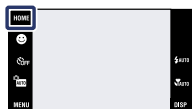

##### ご注意

- フォーマットすると、プロテクトしてある画像も含めて、すべてのデータが消去され、元に戻せません。

### 1-4. 内蔵メモリーへデータを書き戻す方法

通常は、PCからカメラの内蔵メモリーへデータを書き込むことはできない設定になっています。

基板交換後などに、内蔵メモリーへデータを書き戻す場合には、この設定を一時的に変更する必要があります。

設定の変更には、書き込み許可ツール（WriteEnableTool.exe）を使用します。

#### 書き戻し方法

- 1) カメラとPCをマストレージ接続し、ドライバを“Sony Seus USB Driver”に切り替える。
- 2) 書き込み許可ツールとSeusEXを起動する。
- 3) 書き込み許可ツールの[Activate Write Enable Mode]ボタンをクリックする。

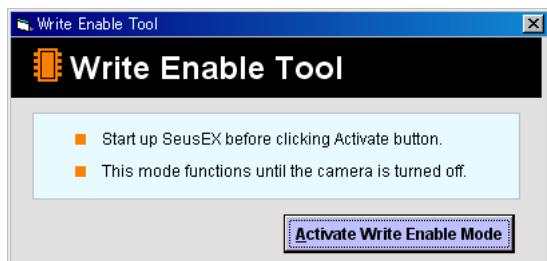

- 4) 設定の変更が終了すると、次のメッセージが表示されます。

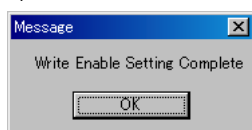

- 5) ドライバを元に戻して、カメラとPCをマストレージ接続する。
- 6) PCに読み出しておいたデータをカメラの内蔵メモリーに書き込む。
- 7) カメラとPCの接続を解除し、カメラの電源をOFFにする。

注意：カメラの電源をOFFにすることにより、書き込み許可の設定が解除されます。

## 1-5. 自己診断機能

### 1-5-1. 自己診断機能について

本機の動作に不具合が生じたとき、自己診断機能が働き、LCD画面に、どう処置したらよいか判断できる表示を行います。自己診断機能については取扱説明書にも掲載されています。

### 1-5-2. 自己診断表示

本機の動作に不具合が生じたとき、LCD画面にアルファベットと4桁の数字が表示され、3.2Hzで点滅します。この5文字の表示によって対応者分類および不具合の生じたブロックの分類、不具合の詳細コードを示します。

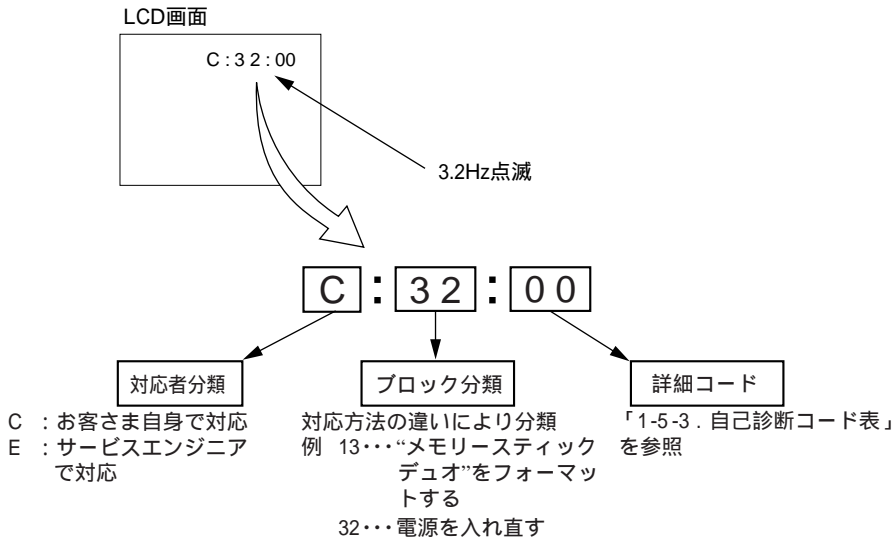

## 1-5-3. 自己診断コード表

自己診断コード			症状 / 状態	対応 / 方法
対応者	ブロック機能	詳細コード		
C	1 3	0 1	内蔵メモリーにメディアエラーがあった。	電源を入れ直す。
			内蔵メモリーにフォーマットエラーがあった。	内蔵メモリーをフォーマットする。
			フォーマットしていない“メモリースティックデュオ”を入れた。	“メモリースティックデュオ”をフォーマットする。
			“メモリースティックデュオ”が壊れている。	新しい“メモリースティックデュオ”に交換する。
			“メモリースティックデュオ”のタイプエラーを検出した。	規格内の“メモリースティックデュオ”を挿入する。
			“メモリースティックデュオ”が読み/書きできない。	電源の入れ直し, または“メモリースティックデュオ”の挿し/外しを数回試す。
C	3 2	0 1	ハードウェアトラブルを検出した。	電源を入れ直す。
E	6 1	0 0	フォーカスが合いにくい。 (フォーカスの初期化ができない)	操作スイッチの電源を入れ直す。 復帰しない場合はレンズブロックのフォーカスリセットセンサ (SY-207基板CN501 ⑳ピン) を点検する。異常なければフォーカスマータ駆動IC (SY-207基板IC503) を点検する。
E	6 1	1 0	ズーム動作の異常。 (ズームレンズの初期化ができない)	操作スイッチの電源を入れ直す。 ズームボタンを操作したときにズーム動作をすればレンズブロックのズームリセットセンサ (SY-207基板CN501 ㉑ピン) を点検する。異常なければズームモータ駆動IC (SY-207基板IC503) を点検する。
E	6 2	0 2	手振れ補正用ICの異常。	手振れ補正用IC (SY-207基板IC503) を点検または交換する。
E	6 2	1 0	手振れ補正用ICの異常。 (レンズ初期化異常)	手振れ補正用IC (SY-207基板IC503) を点検または交換する。
E	6 2	1 1	レンズオーバーヒート (PITCH)	光学手振れ補正ブロックのホール素子 (PITCH) (SY-207基板CN501 ㉒, ㉓ピン) を点検する。異常なければ PITCH/YAW角速度センサ (SY-207基板SE510) 周辺の回路を点検する。
E	6 2	1 2	レンズオーバーヒート (YAW)	光学手振れ補正ブロックのホール素子 (YAW) (SY-207基板CN501 ㉔, ㉕ピン) を点検する。異常なければ PITCH/YAW角速度センサ (SY-207基板SE510) 周辺の回路を点検する。
E	6 2	2 0	サーミスタの異常。	光学手振れ補正ブロックのサーミスタ (SY-207基板CN501 ㉖ピン) を点検する。
E	9 1	0 1	フラッシュの充電異常。	フラッシュユニットを点検または交換する。(Note)
E	9 2	0 0	規定外の充電電池が使用された。	規定の充電電池を使用する。

Note : 交換後は, 必ず「1-6. フラッシュエラー発生時の対処法」を行って下さい。

## 1-6. フラッシュエラー発生時の対処法

本機はフラッシュエラー（自己診断コードE：91：01）が発生した場合、高電圧による異常を防止するために自動的にフラッシュ充電および発光禁止の設定になります。

フラッシュエラー発生後はエラーの解除を行う必要があります。エラーの解除はホーム画面から初期化操作を実行することにより行います。

### フラッシュエラーの解除方法

#### 設定リセット

お買い上げ時の設定に戻します。  
[設定リセット]を実行しても、画像は削除されません。

1 HOME → (設定) → [本体設定] → OK  
→ [設定リセット] → OK → [実行]

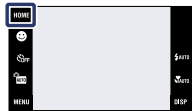

#### ご注意

- ・ 設定リセット中は電源が切れないようにご注意ください。

## 2. DISASSEMBLY

### NOTE FOR REPAIR

- Make sure that the flat cable and flexible board are not cracked or bent at the terminal.  
Do not insert the cable insufficiently nor crookedly.
- When remove a connector, don't pull at wire of connector. It is possible that a wire is snapped.
- When installing a connector, don't press down at wire of connector.  
It is possible that a wire is snapped.
- Do not apply excessive load to the gilded flexible board.

Cut and remove the part of gilt which comes off at the point.  
(Be careful or some pieces of gilt may be left inside)

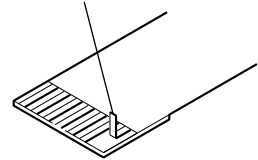

### DISCHARGING OF THE ST-199 FLEXIBLE BOARD'S CHARGING CAPACITOR (C901, C902)

The charging capacitor (C901, C902) of the ST-199 flexible board is charged up to the maximum 315 V potential.

There is a danger of electric shock by this high voltage when the capacitor is handled by hand. The electric shock is caused by the charged voltage which is kept without discharging when the main power of the unit is simply turned off. Therefore, the remaining voltage must be discharged as described below.

#### Preparing the Short Jig

To preparing the short jig, a small clip is attached to each end of a resistor of 1 k $\Omega$  / 1 W (1-215-869-11).

Wrap insulating tape fully around the leads of the resistor to prevent electrical shock.

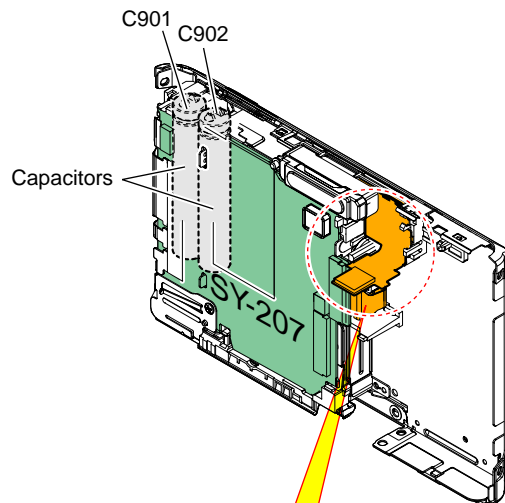
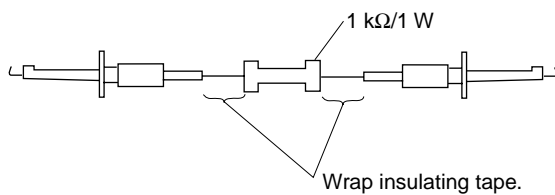

**Note:** High-voltage cautions

#### Discharging the Capacitor

Short-circuit between the two points with the short jig about 10 seconds.  
To avoid the spark with the metal plate, wrap the short jig with the insulation tape.

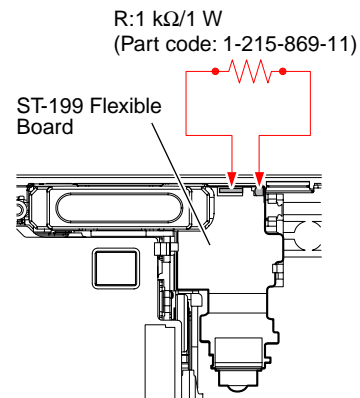

## 2-1. IDENTIFYING PARTS

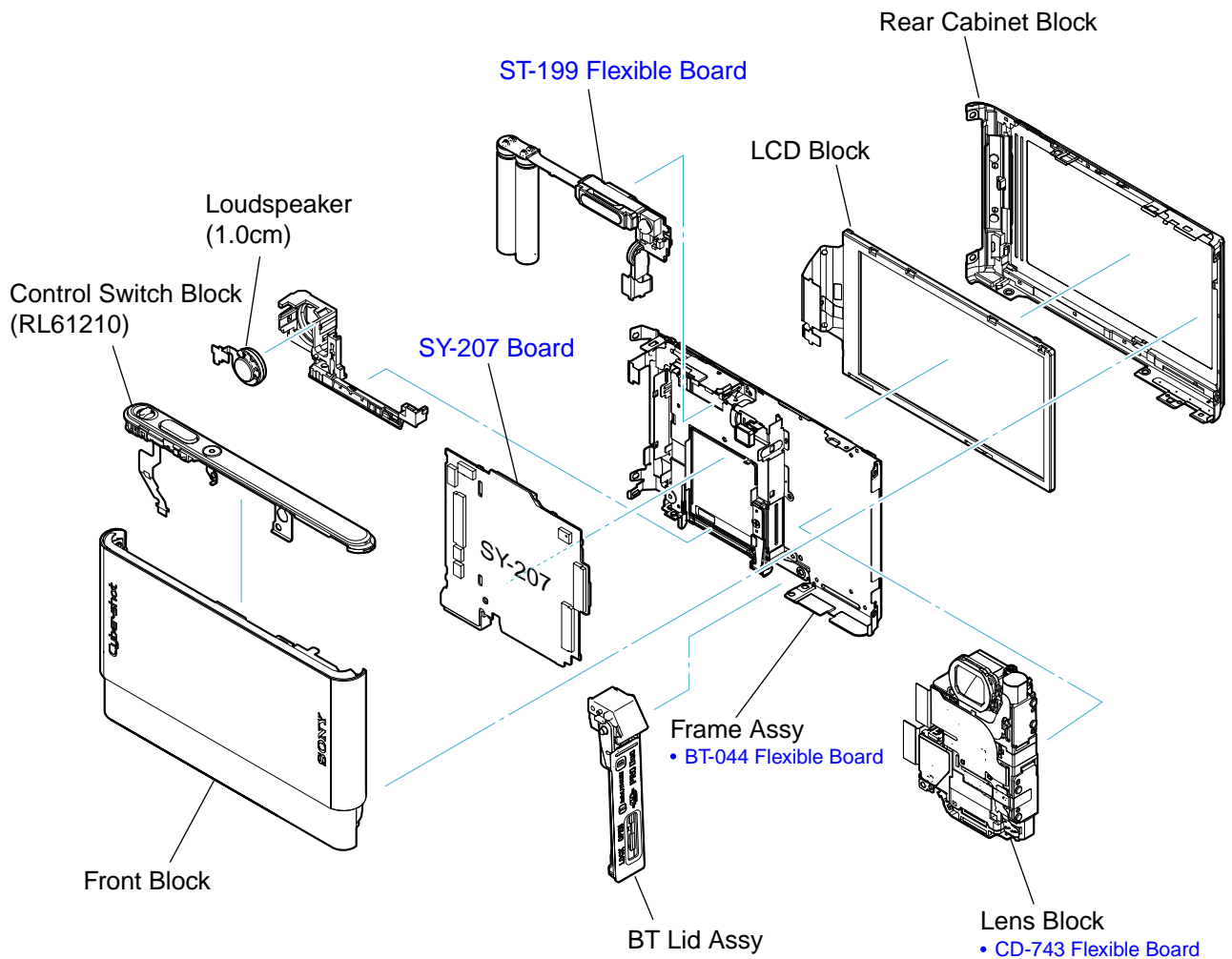

### - DISASSEMBLY FLOW -

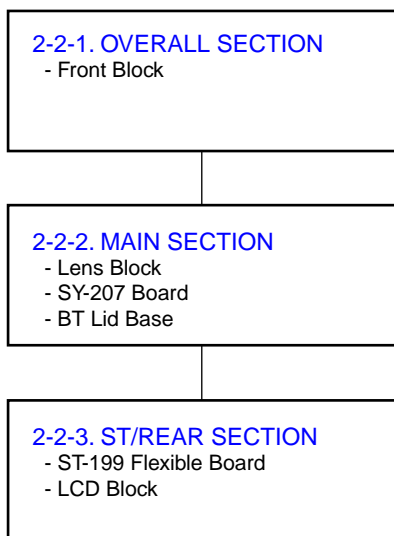

## 2-2. DISASSEMBLY

EXPLODED VIEW

HARDWARE LIST

### 2-2-1. OVERALL SECTION

Follow the disassembly in the numerical order given.

① Front Block (①-1 to ①-14)

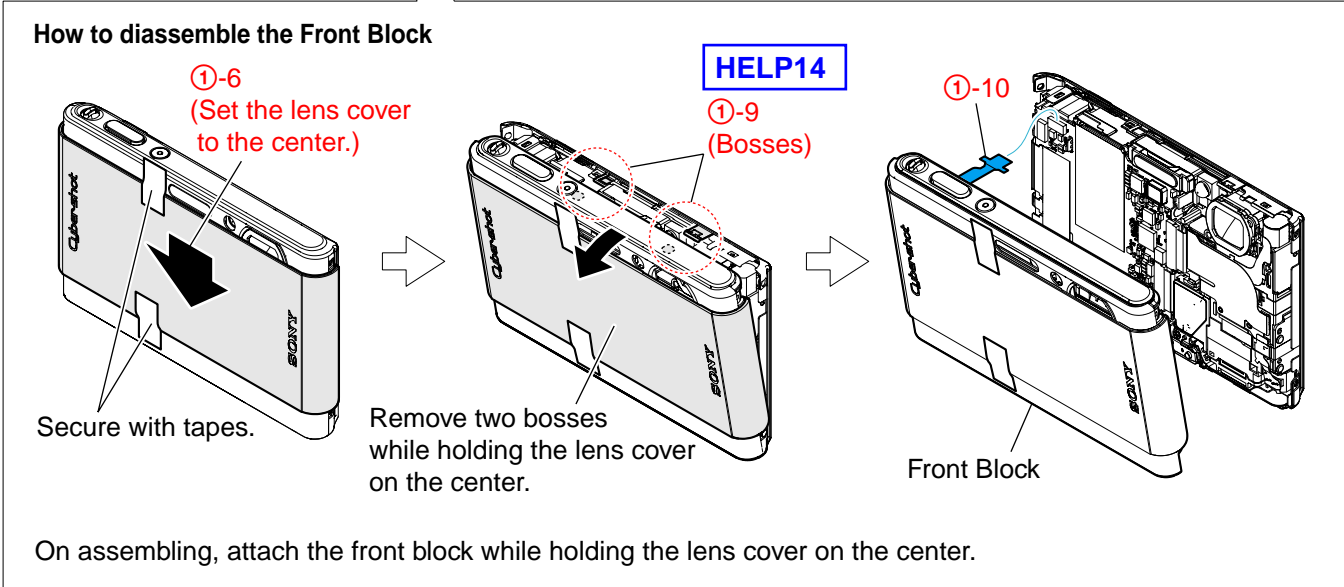
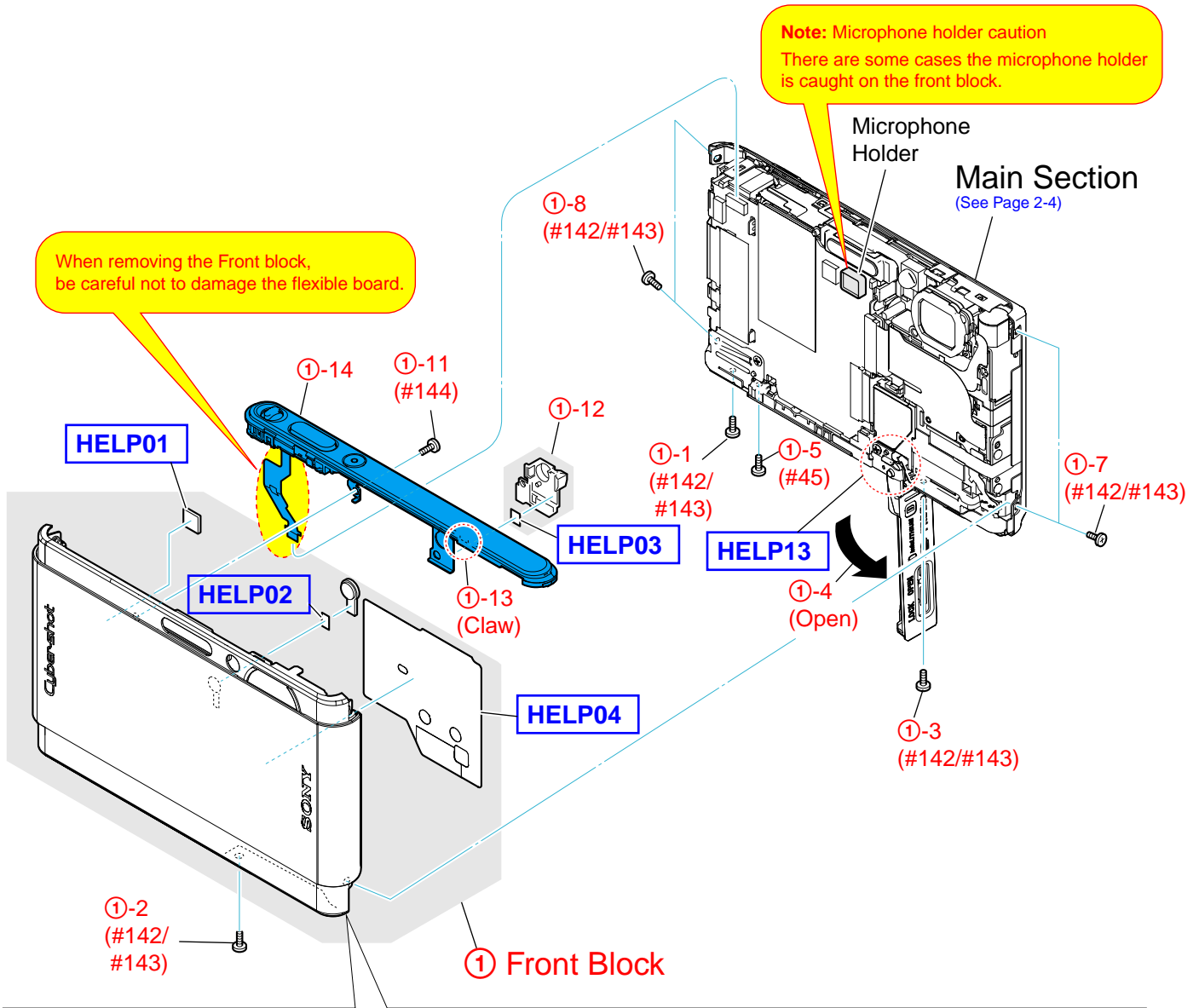

## 2-2-2. MAIN SECTION

Follow the disassembly in the numerical order given.

- ① Lens Block (①-1 to ①-6)
- ② SY-207 Board (②-1 to ②-12)
- ③ BT Lid Base (③-1 to ③-7)

EXPLODED VIEW

HARDWARE LIST

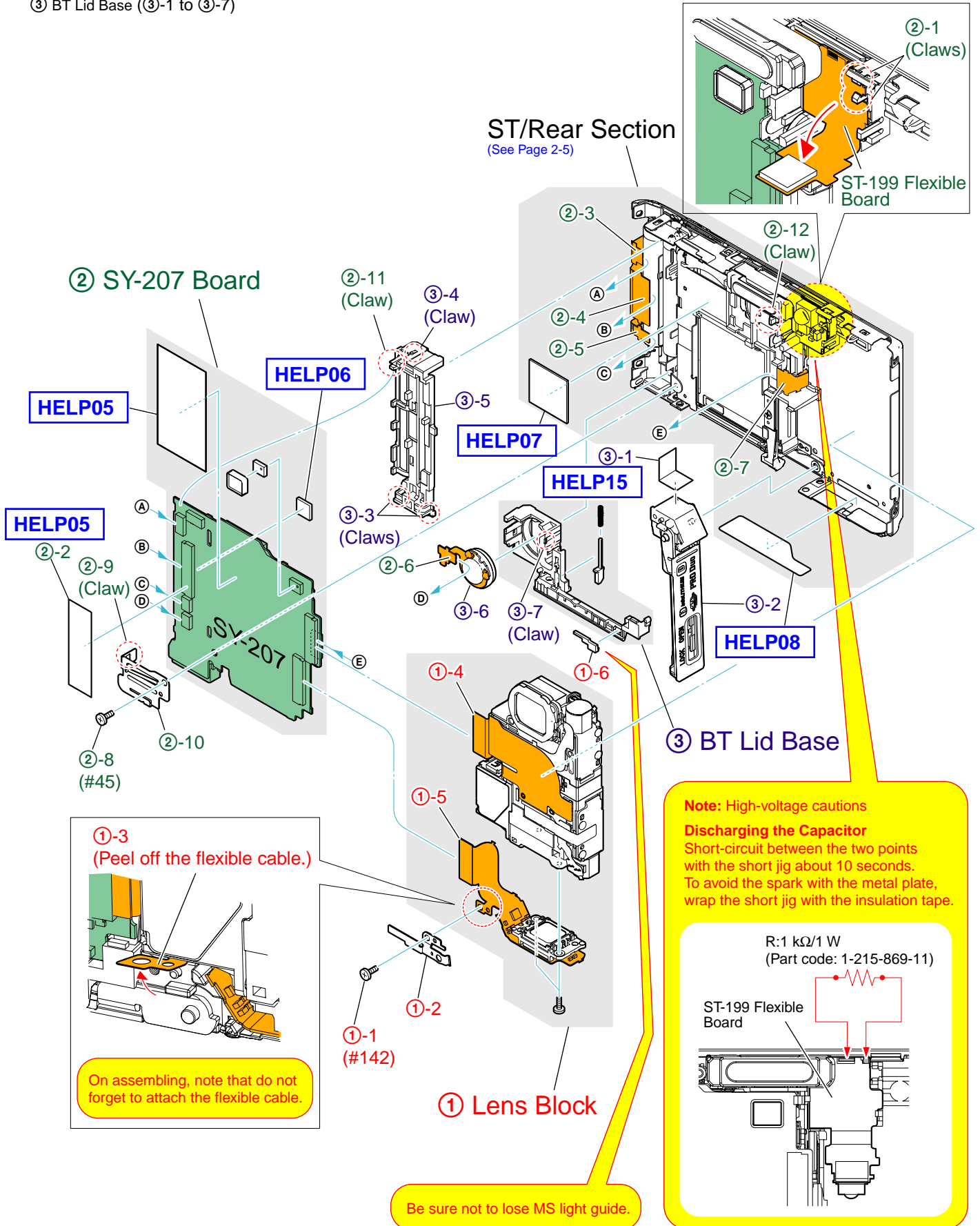

### 2-2-3. ST/REAR SECTION

Follow the disassembly in the numerical order given.

- ① ST-199 Flexible Board (①-1 to ①-3)
- ② LCD Block (②-1 to ②-5)

EXPLODED VIEW

HARDWARE LIST

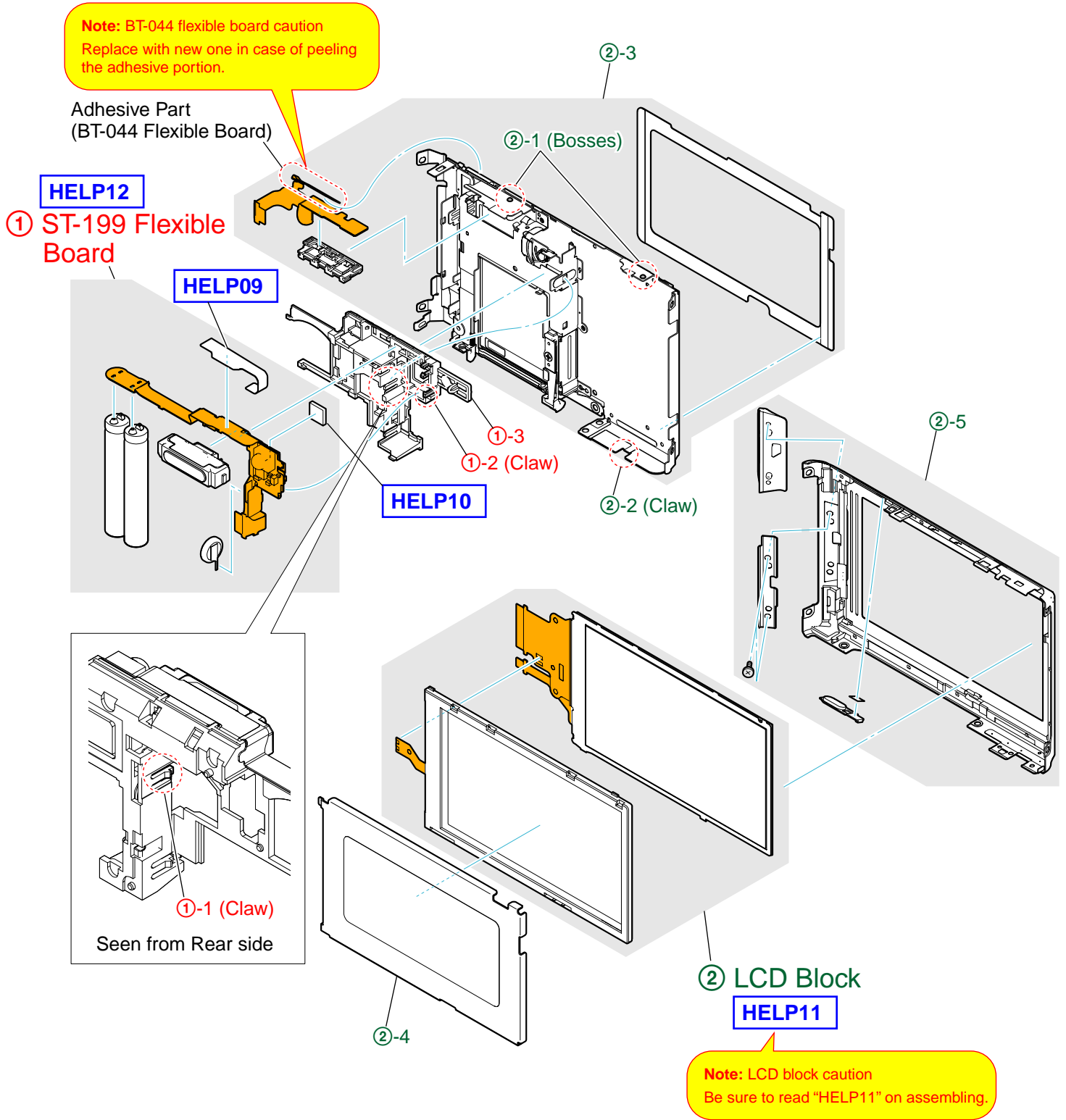

# HELP

Sheet attachment positions and procedures of processing the flexible boards/harnesses are shown.

## HELP01

### FRONT CUSHION PUTTING POSITION

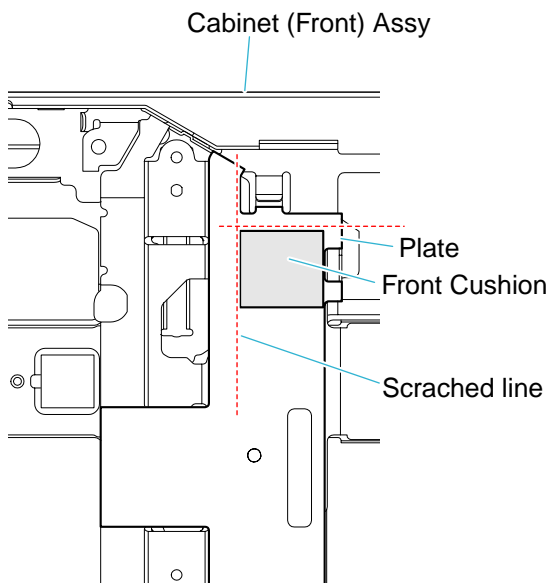

## HELP02

### AF WINDOW ADHESIVE SHEET PUTTING POSITION

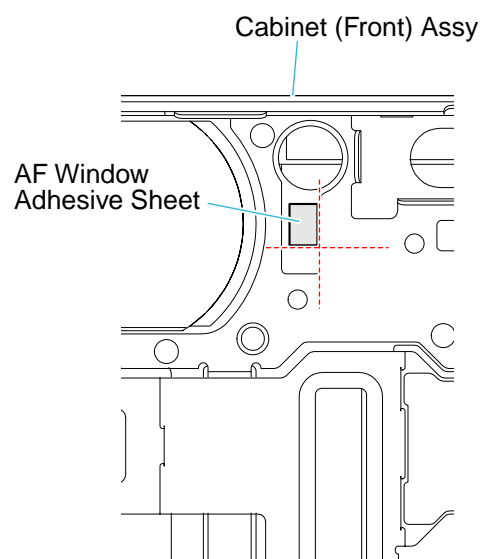

## HELP03

### PLAY BUTTON ADHESIVE SHEET PUTTING POSITION

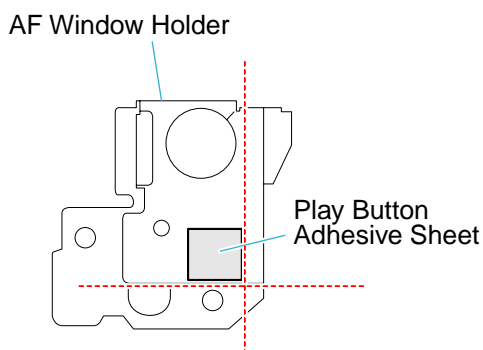

## HELP04

### LENS FLEXIBLE PROTECTION SHEET PUTTING POSITION

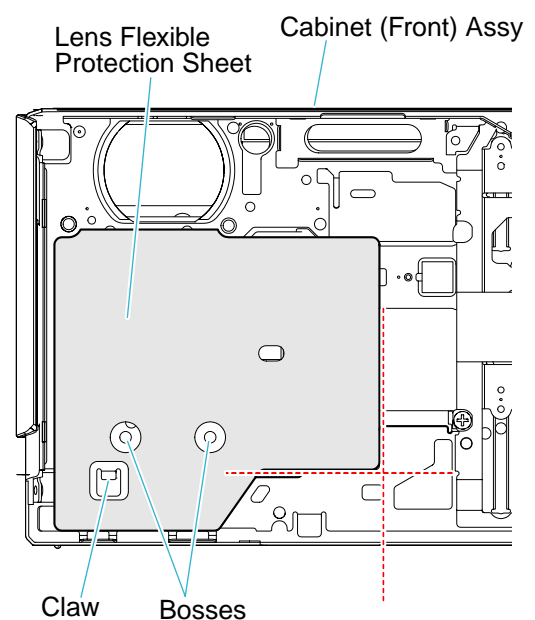

**HELP05**

**SY INSULATING SHEET, INSULATING SHEET (A) PUTTING POSITION**

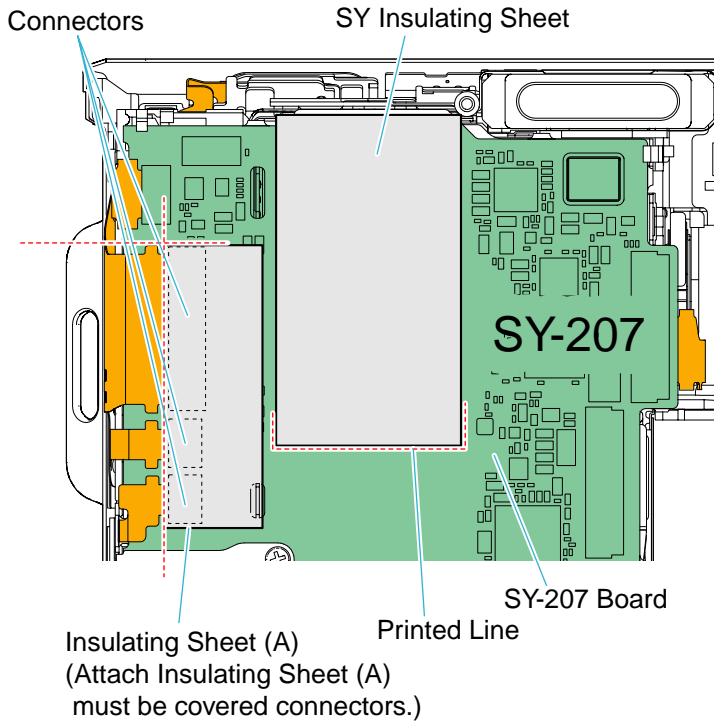

**HELP06**

**FRONT CUSHION PUTTING POSITION**

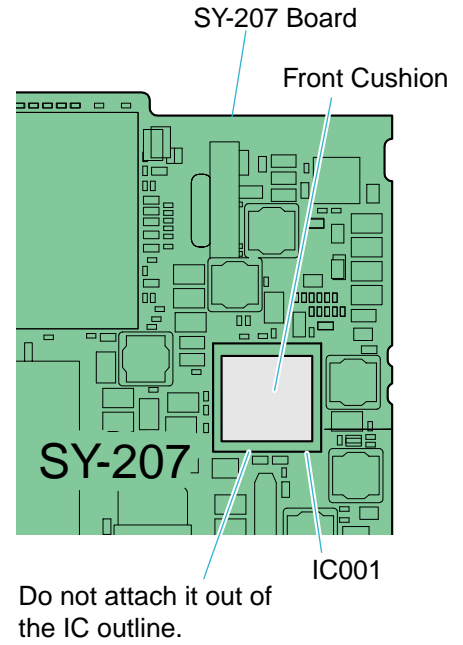

**HELP07**

**REAR CUSHION PUTTING POSITION**

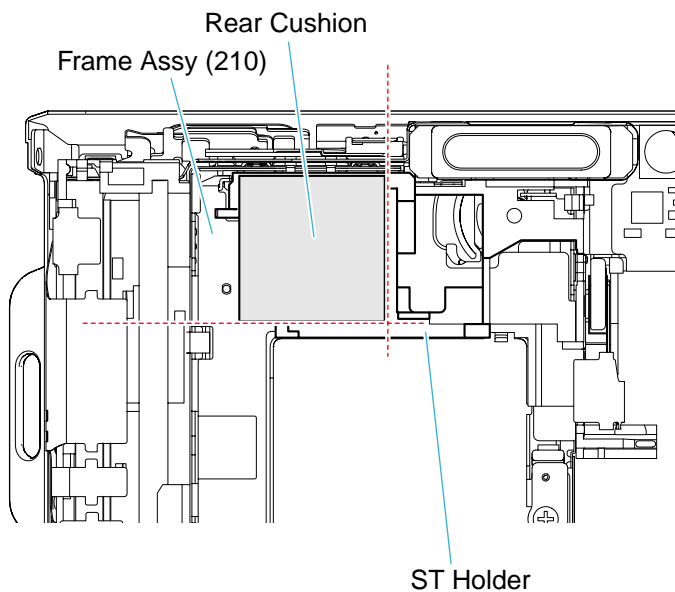

**HELP08**

**CD LIGHT INTERCEPTION SHEET  
PUTTING POSITION**

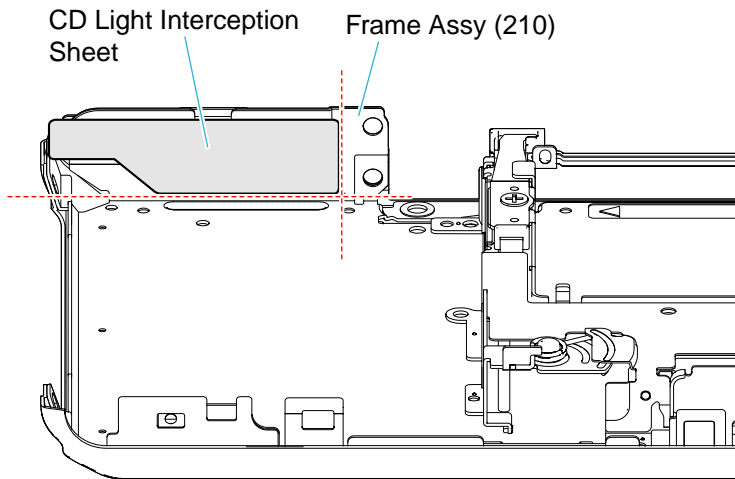

**HELP09**

**ST CUSHION PUTTING POSITION**

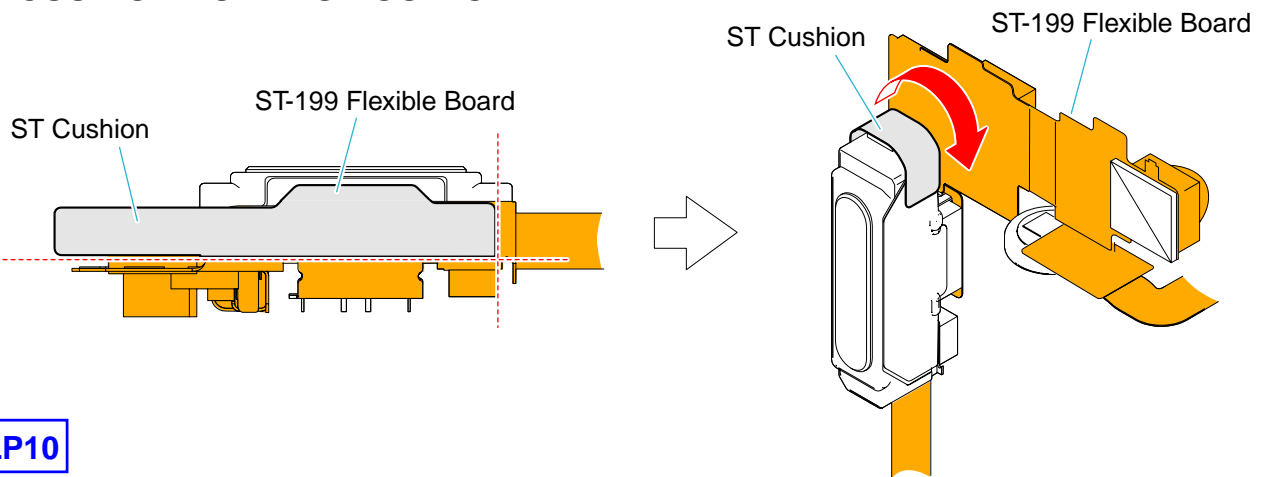

**HELP10**

**AF CUSHION PUTTING POSITION**

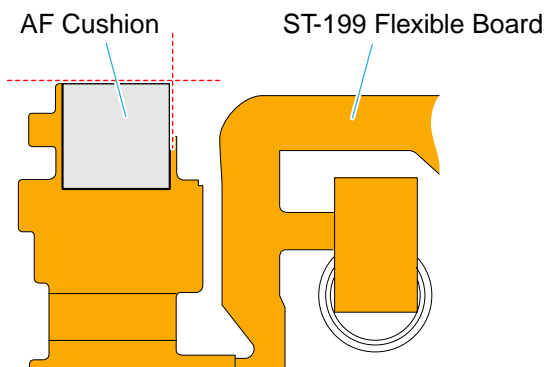

## HELP11

### INSTALLATION CAUTIONS OF THE LCD BLOCK

- ① Attach four claws of FTS block assy (30SHGU08) to the light guide plate (3.0) block in the order A, B, C and D.

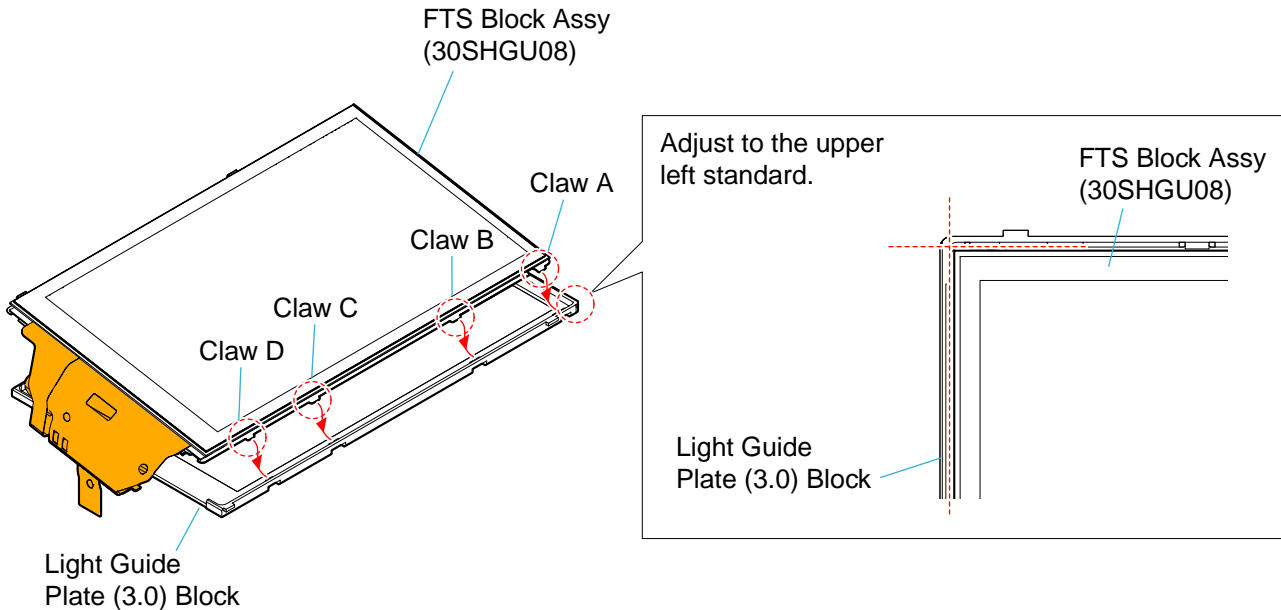

- ② Attach two claws of FTS block assy (30SHGU08) to the light guide plate (3.0) block in the order E and F. And check the claws fit properly.

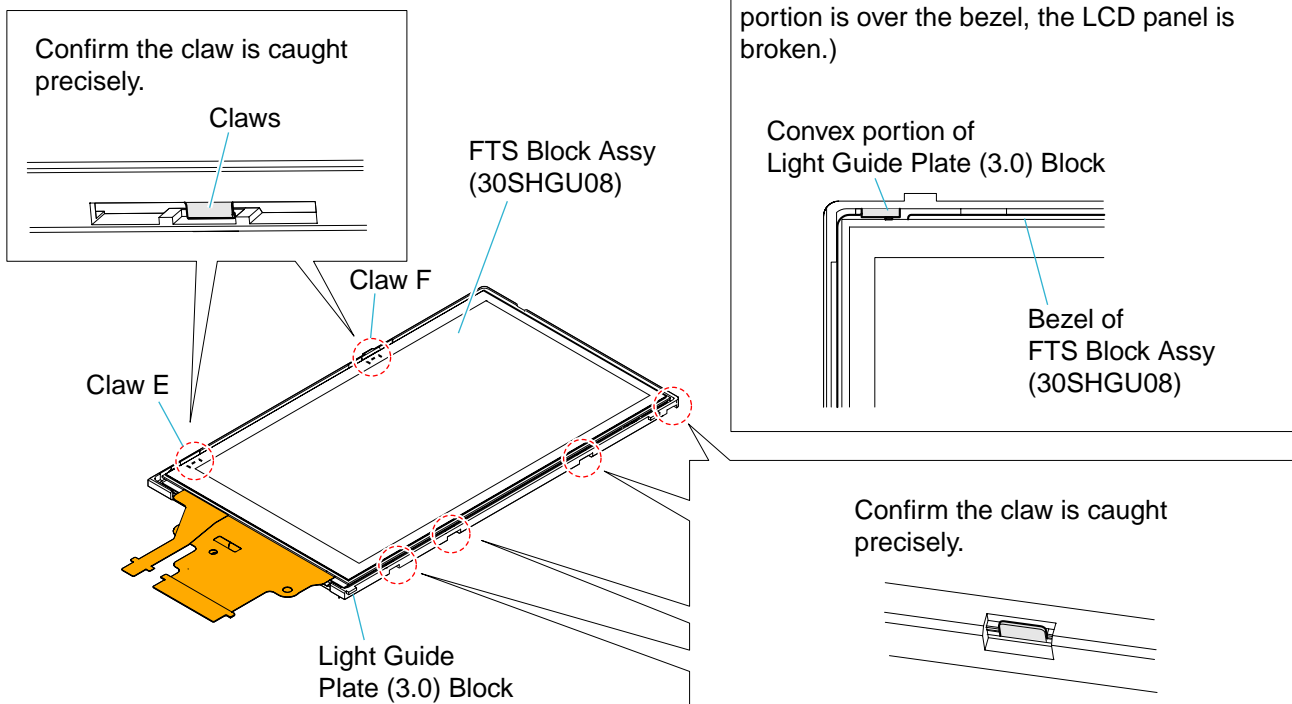

③ Solder two points.

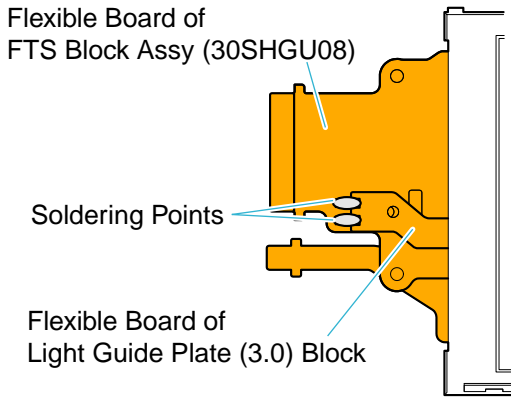

④ Fit two claws by pushing them.  
Fit other claws by pressing with finger.

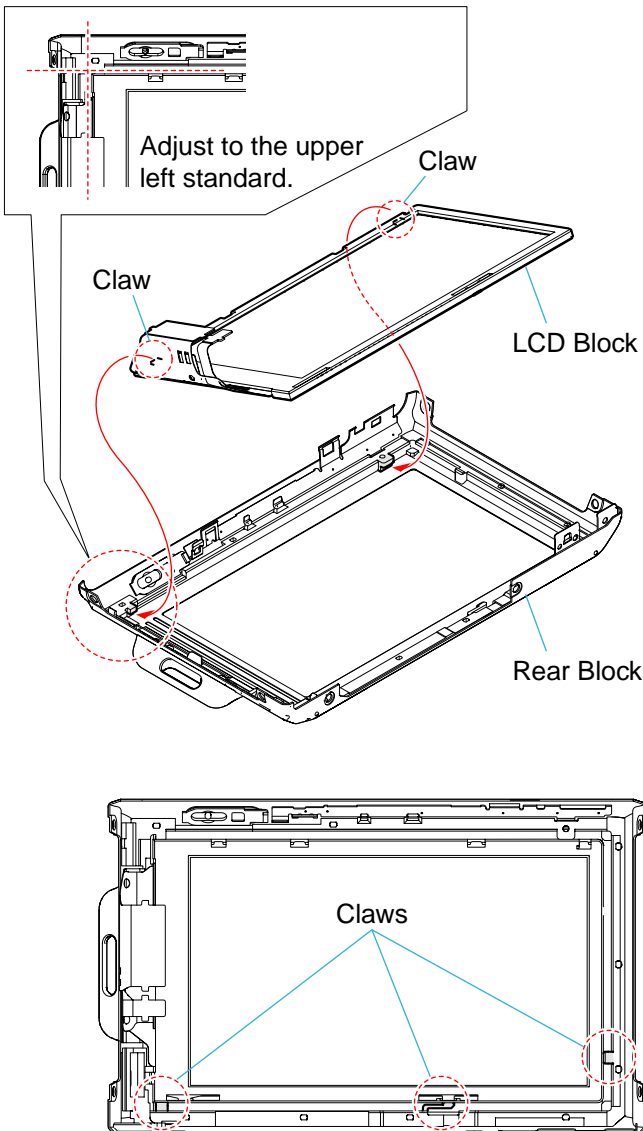

⑤ Place BL Frame.

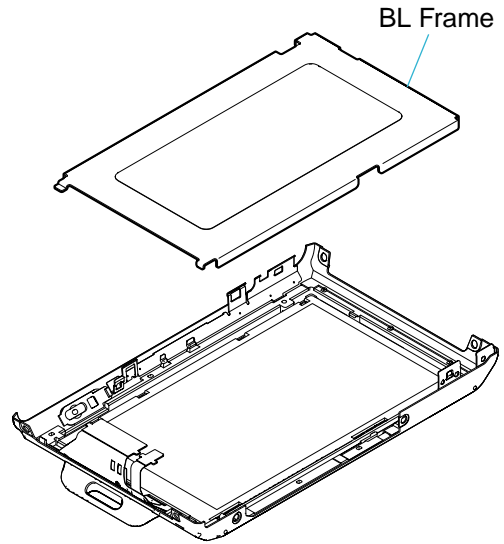

⑥ Attach LCD cushion to main frame (210).  
Fit Main Frame Block by fitting three bosses.

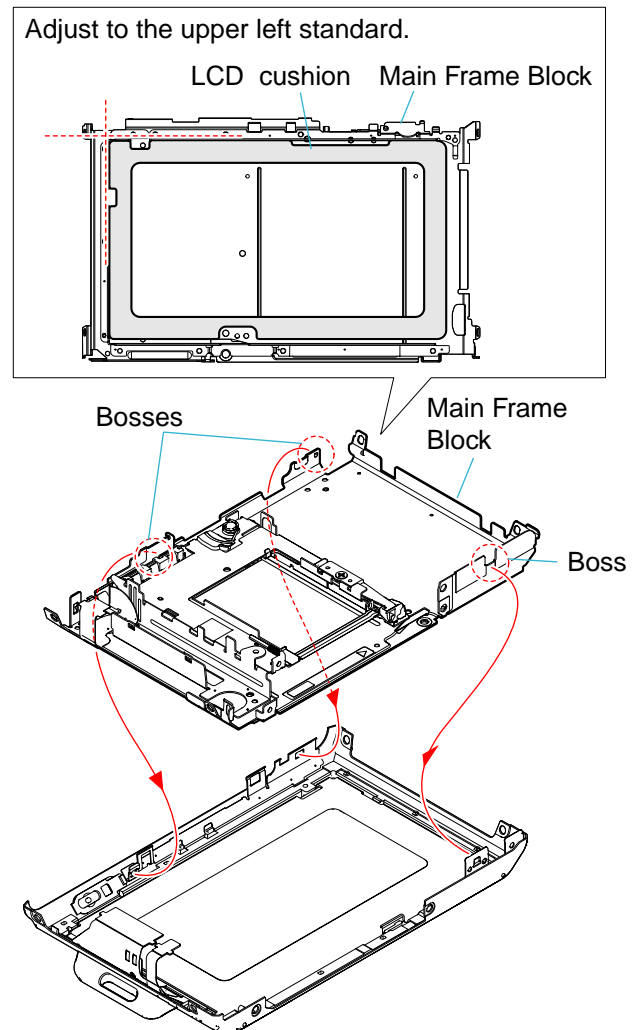

## HELP12

### THE METHOD OF ATTACHMENT OF ST-199 FLEXIBLE BOARD

- ① Fold dotted line parts of ST-199 flexible board as shown in figure.

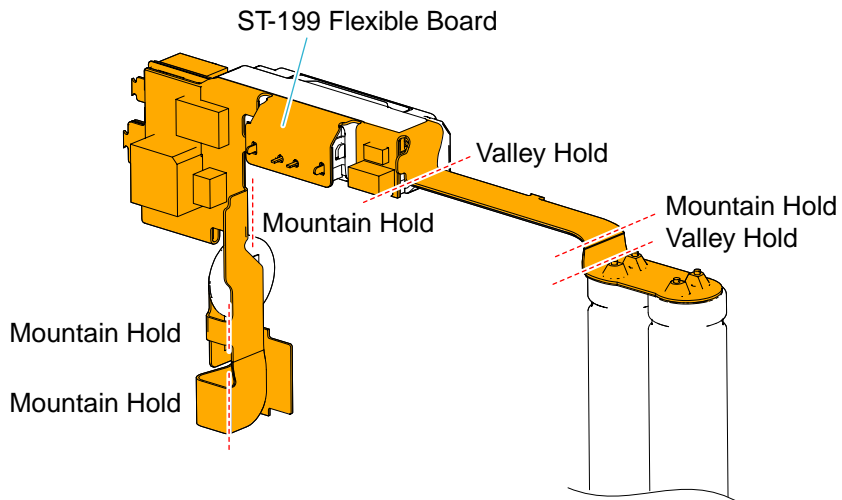

- ② Install ST-199 Flexible board to ST holder as shown in figure.

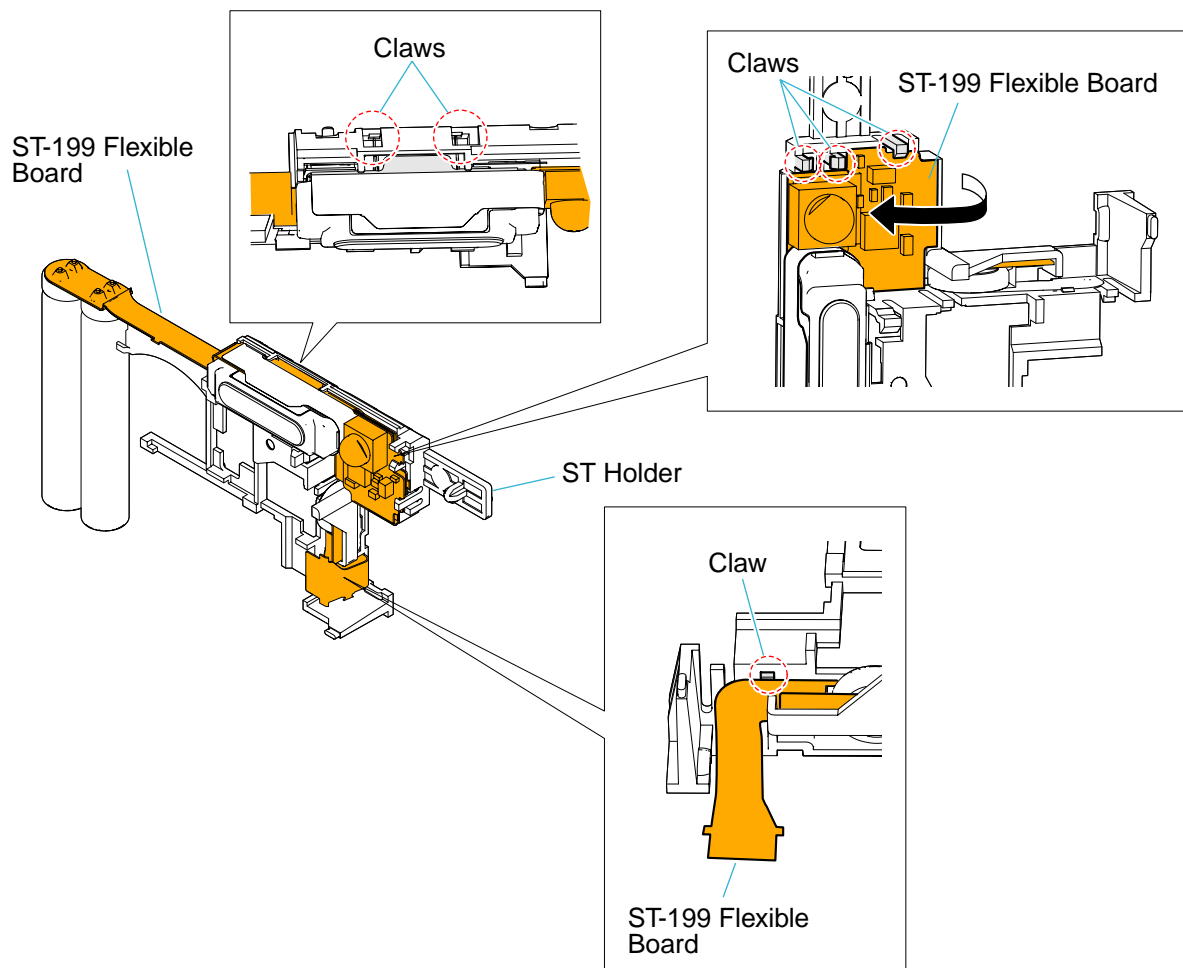

**HELP13**

**NOTES ON ATTACHING BT HINGE SHAFT (210)**

In case of BT hinge shaft (210) is coming out, insert it with care of followings.

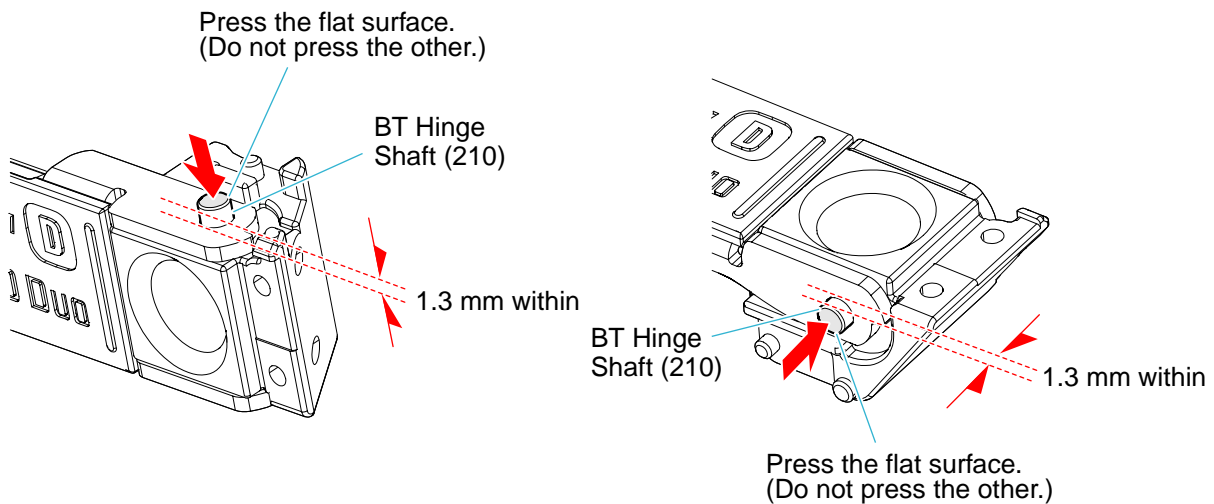
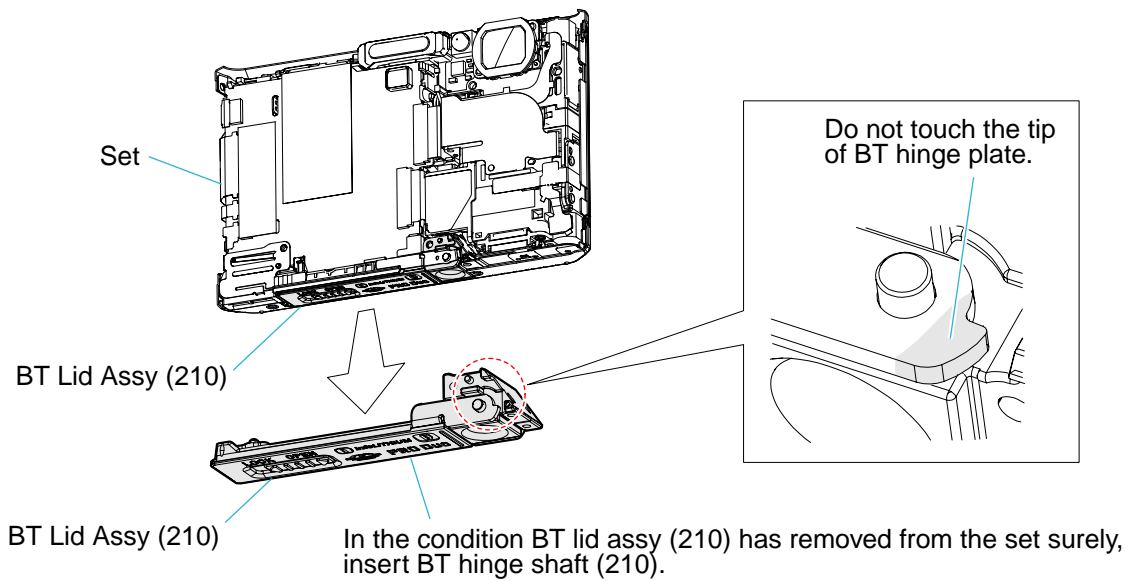
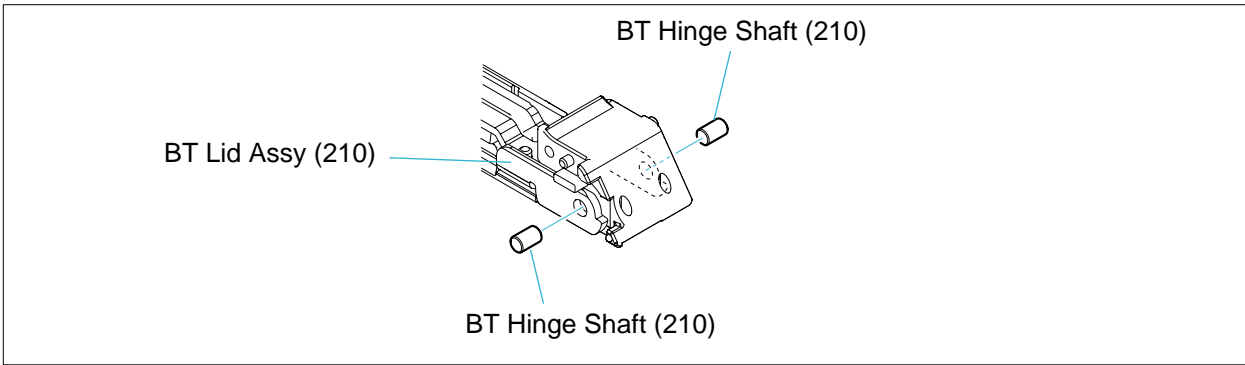

## HELP14

### NOTES ON ASSEMBLING FRONT BLOCK

In case of assembling front block, bend two claws on the cabinet rear block as shown below.  
(Once front block is removed causes the engagement of two claws on the cabinet rear block and two bosses on the control switch block (RL61210) becomes loose.)

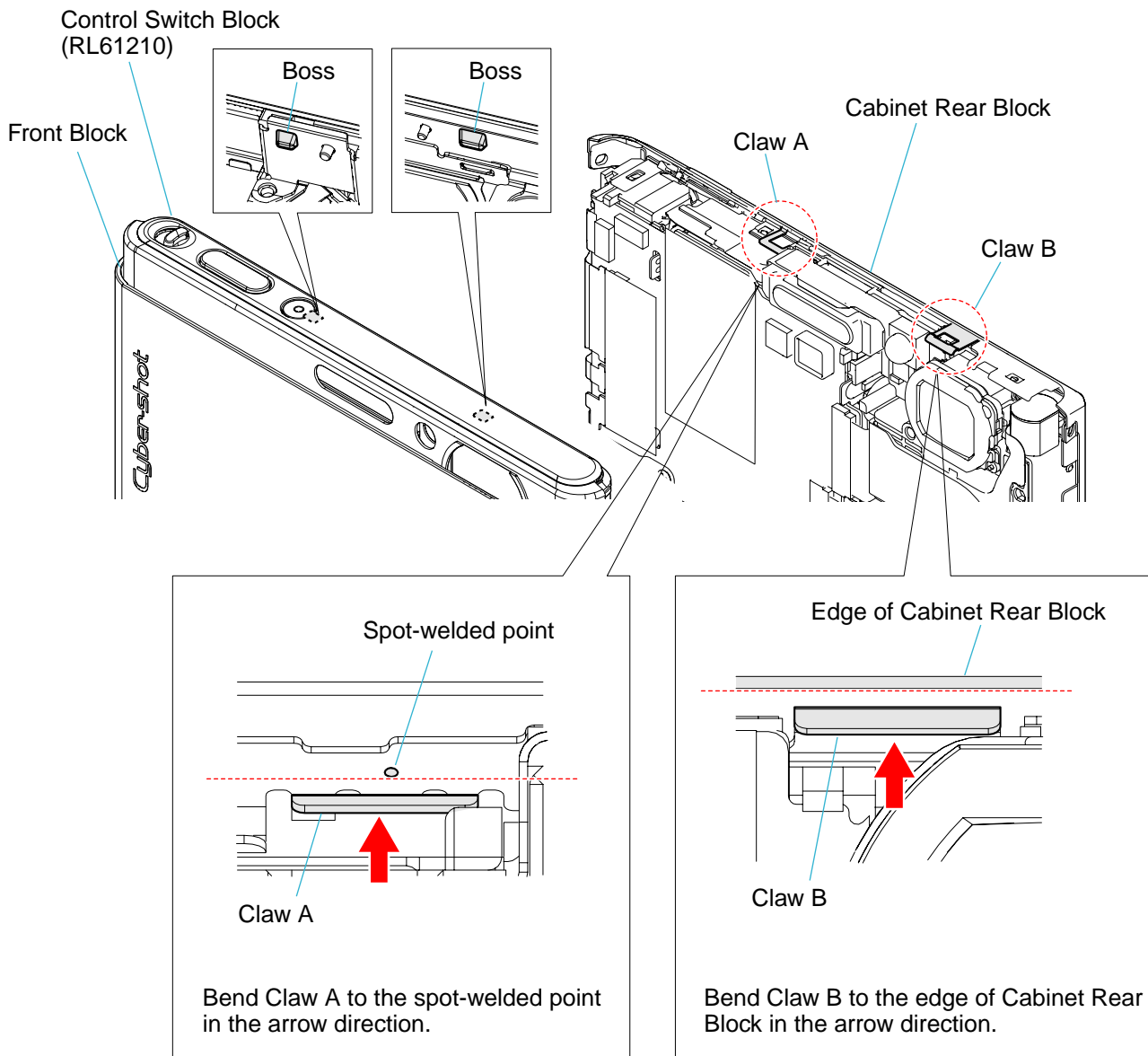

**HELP15**

**RADIATION SHEET (K)  
PUTTING POSITION**

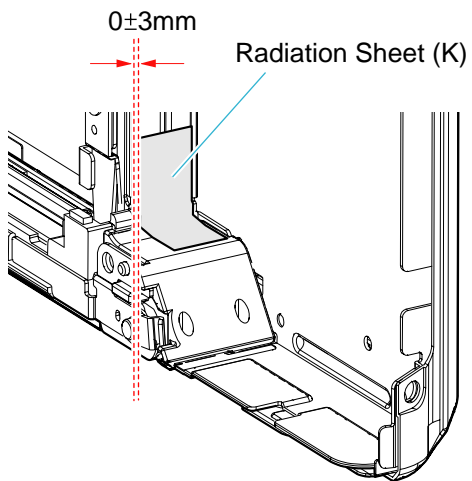

## 3. BLOCK DIAGRAMS

### Link

• [OVERALL BLOCK DIAGRAM \(1/2\)](#)

• [POWER BLOCK DIAGRAM \(1/2\)](#)

• [OVERALL BLOCK DIAGRAM \(2/2\)](#)

• [POWER BLOCK DIAGRAM \(2/2\)](#)

### 3. BLOCK DIAGRAMS

3-1. OVERALL BLOCK DIAGRAM (1/2) ( ) : Number in parenthesis ( ) indicates the division number of schematic diagram where the component is located.

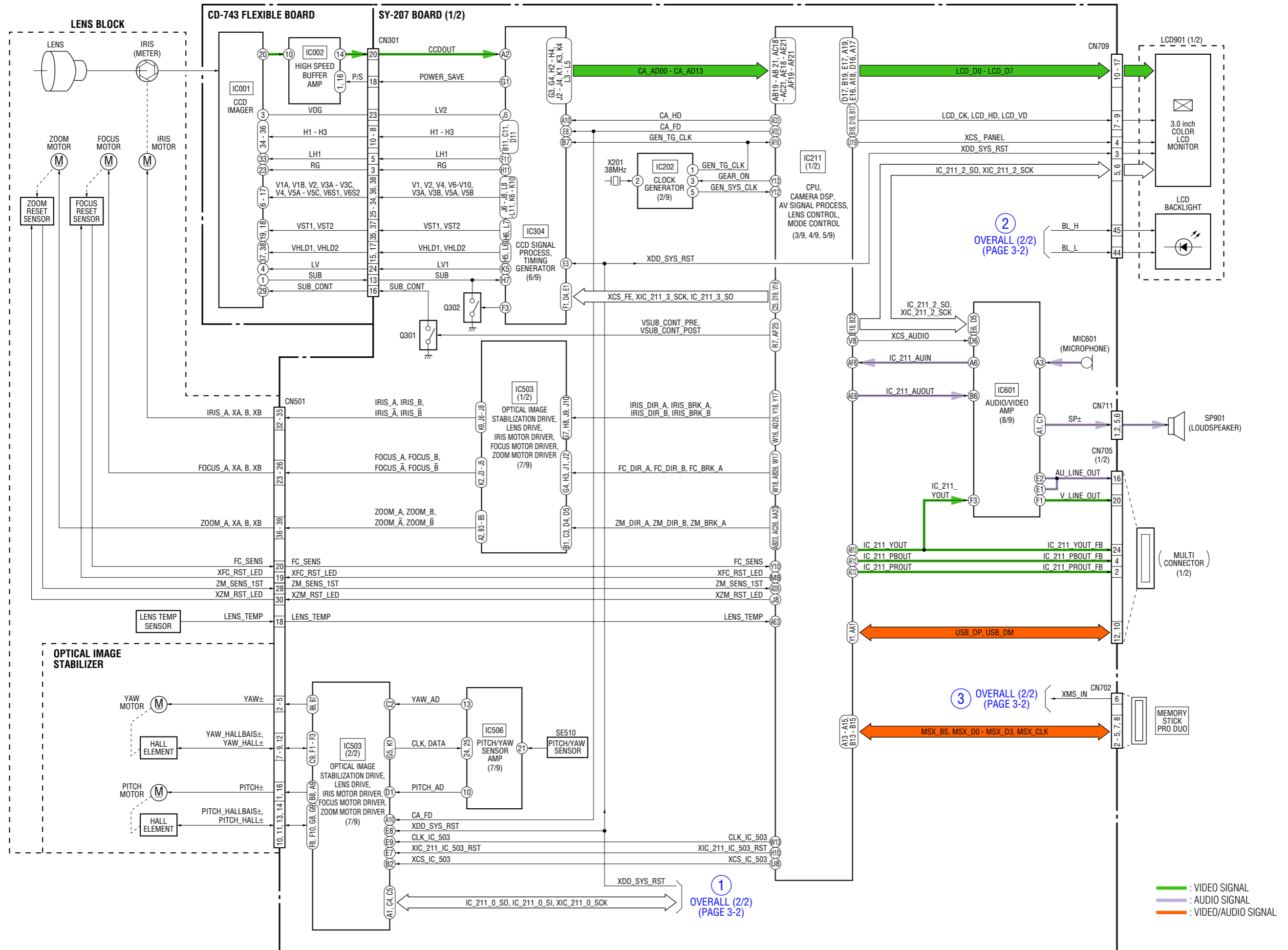

3-2. OVERALL BLOCK DIAGRAM (2/2) ( ) : Number in parenthesis ( ) indicates the division number of schematic diagram where the component is located.

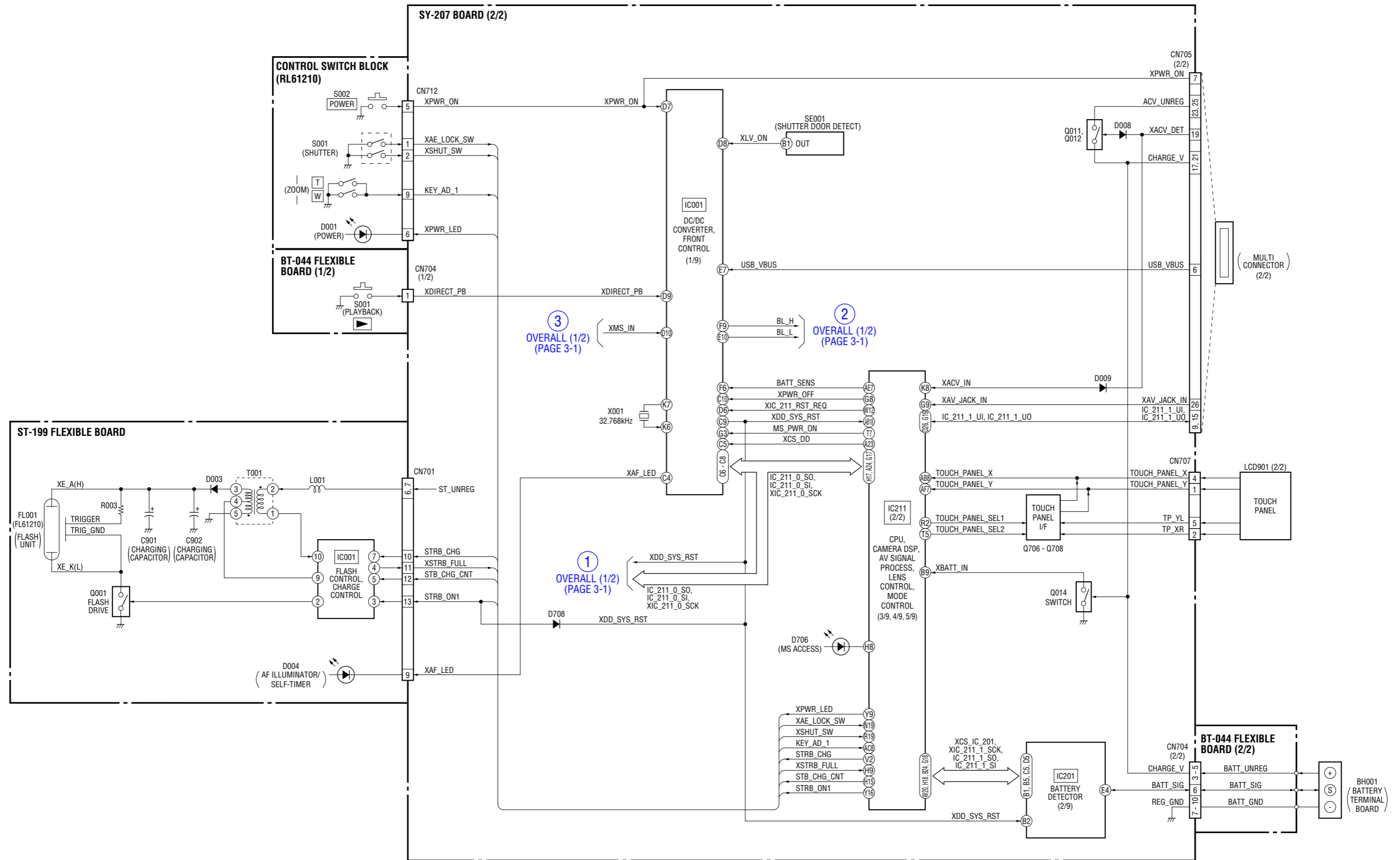

3-3. POWER BLOCK DIAGRAM (1/2)

( ) : Number in parenthesis ( ) indicates the division number of schematic diagram where the component is located.

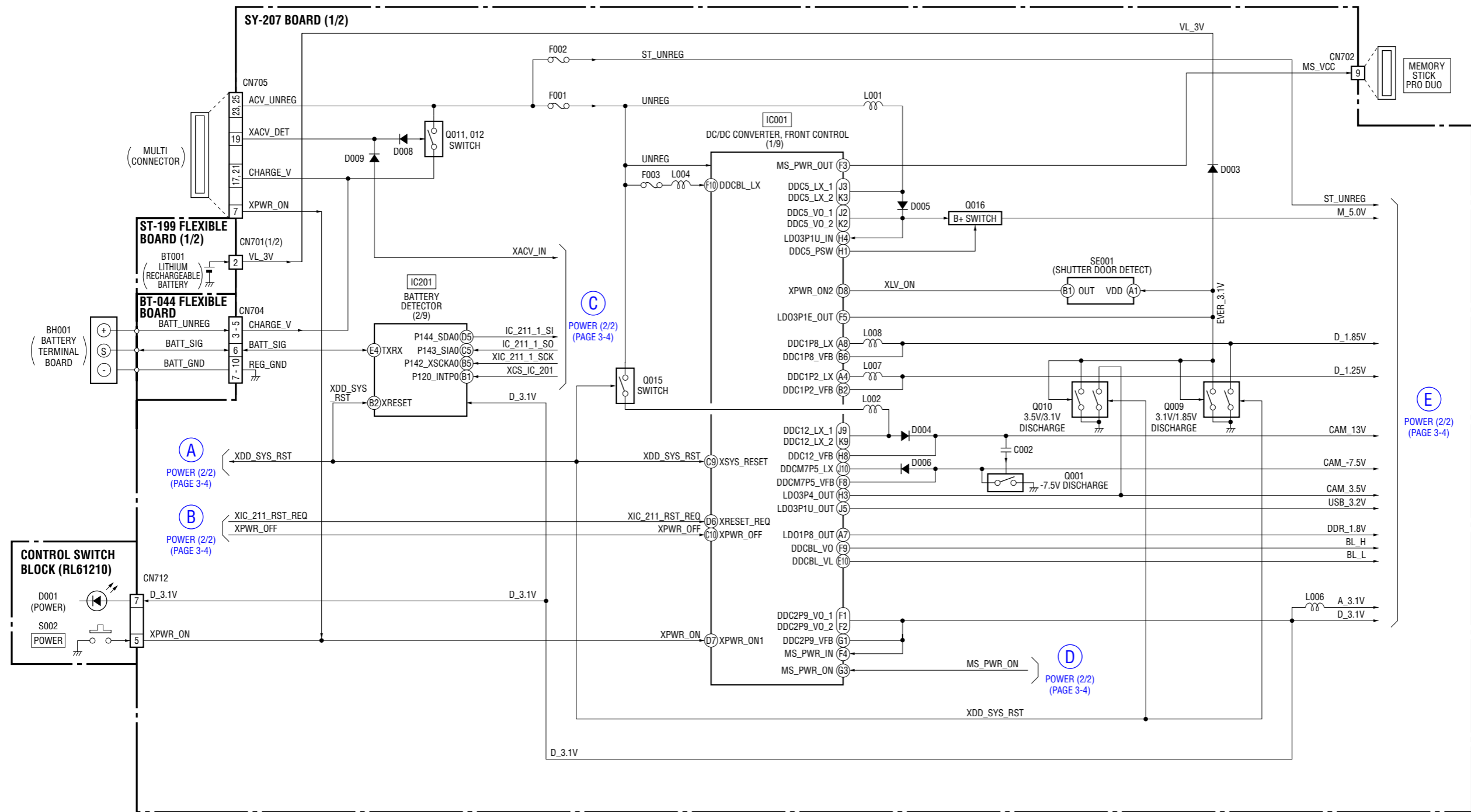

3-4. POWER BLOCK DIAGRAM (2/2)

( ) : Number in parenthesis ( ) indicates the division number of schematic diagram where the component is located.

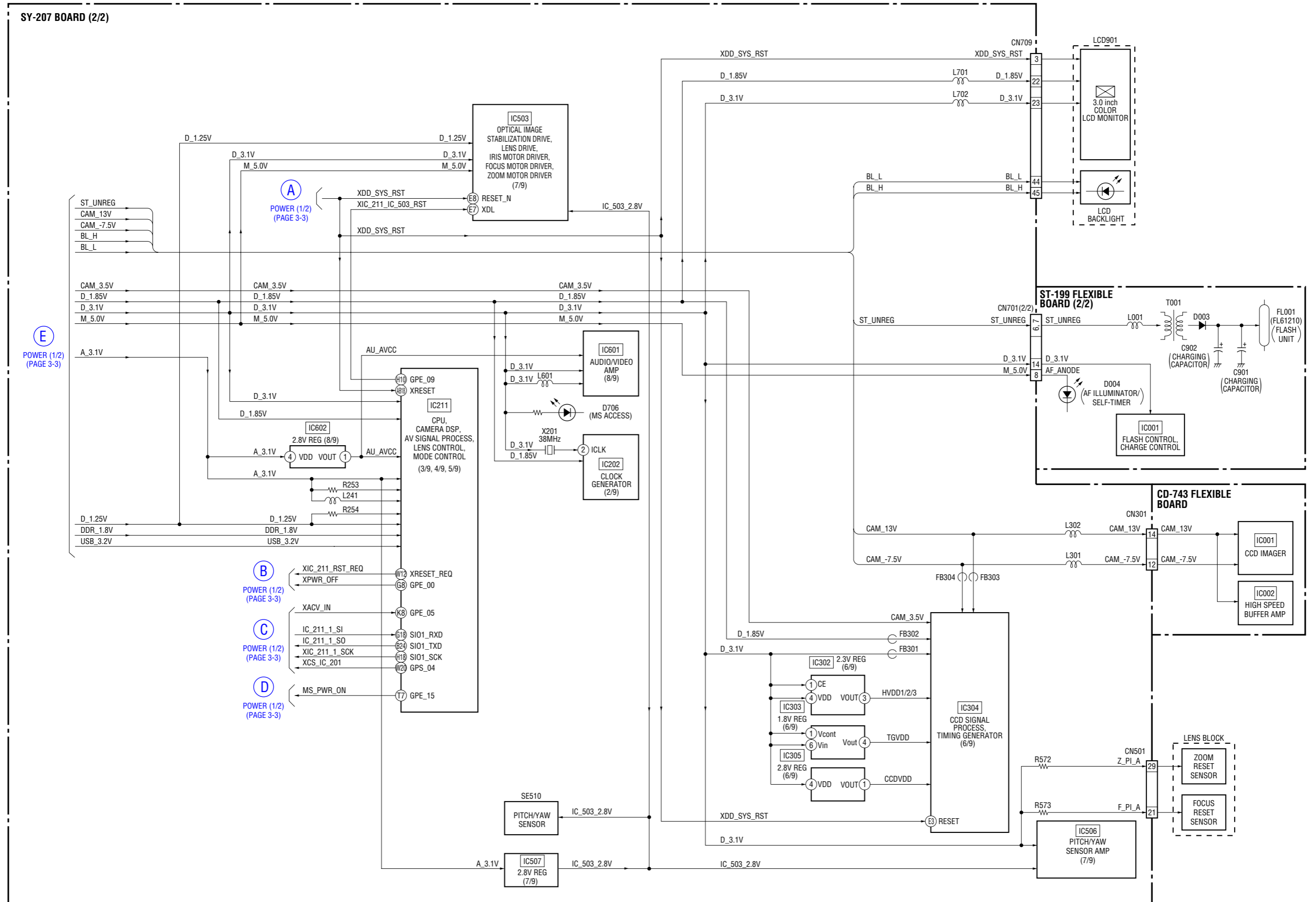

# 4. PRINTED WIRING BOARDS AND SCHEMATIC DIAGRAMS

## 4-1. FRAME SCHEMATIC DIAGRAM

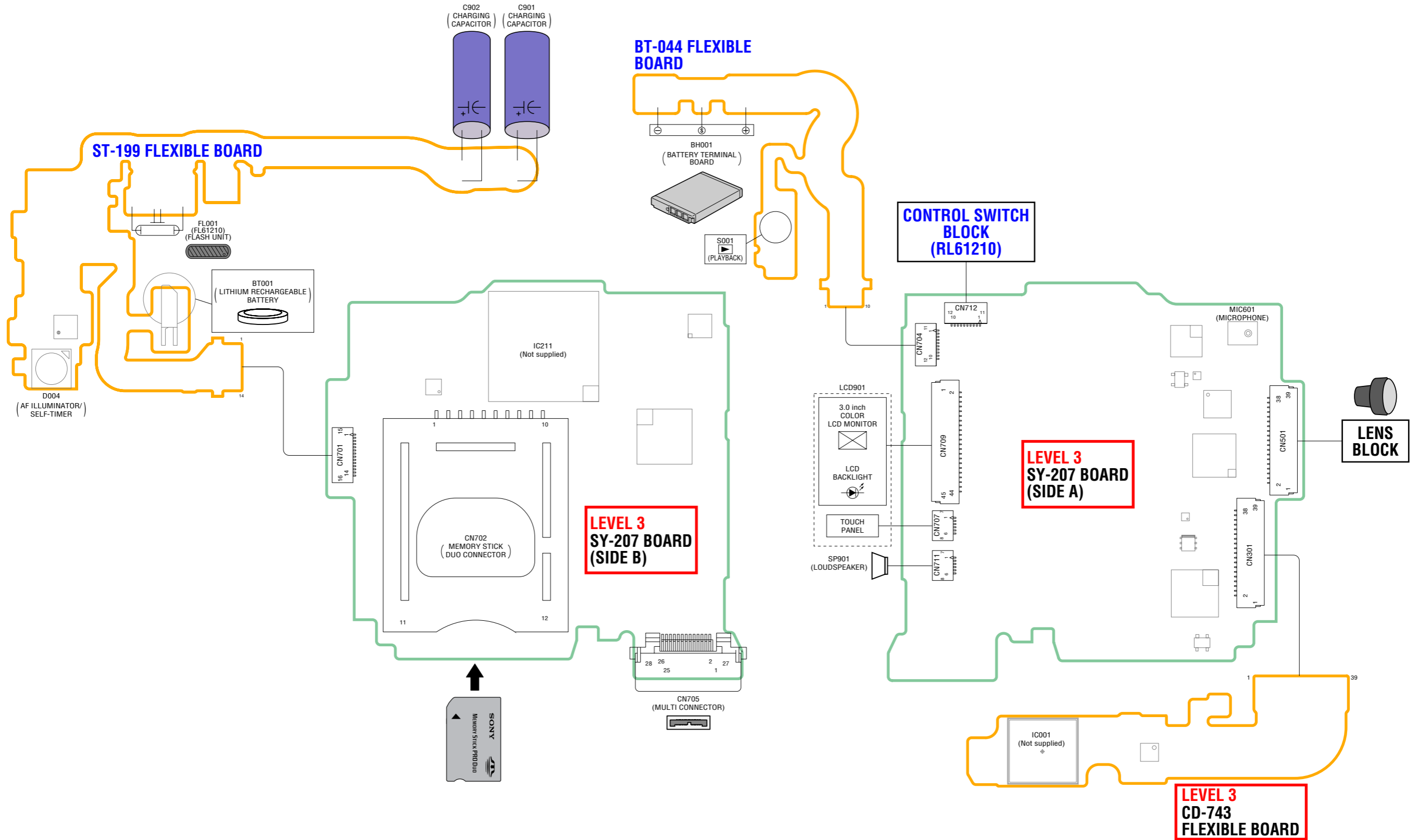

## 4-2. SCHEMATIC DIAGRAMS

### Link

- **ST-199 FLEXIBLE BOARD  
(FLASH DRIVE)**

- **CONTROL SWITCH BLOCK  
(RL61210)**

- **BT-044 FLEXIBLE BOARD  
(BATTERY IN/PLAYBACK SWITCH)**

- **COMMON NOTE FOR SCHEMATIC DIAGRAMS**



## (JAPANESE)

## 回路図共通ノート

(他に必要なノートは各ブロックに記載してあります)

## 【回路図ノート】

- ・ケミコン、タンタルを除くコンデンサで、耐圧50V以下のものはその耐圧を省略。単位はすべて $\mu\text{F}$  (pはpF)。
- ・チップ抵抗で指示のないものは、1/10W以下。  
k = 1000 , M = 1000k
- ・チップ部品交換時の注意  
取り外した部品は再使用せず、未使用の部品をご使用ください。

タンタルコンデンサのマイナス側は熱に弱いので注意してください。







- ・チップ部品には下記のように表示したものがああります。

例	C 541	L 452
	22U	10UH
	TA A	2520

種類	ケースサイズ	外形寸法 (mm)
----	--------	-----------

- ・抵抗、コンデンサ、ICなど定数にXXがあるものは、使用していない事を示しています。このため、使用していない回路が記載されている事があります。
- ・印のある部品は、機種などにより異なりますので機能別マウント一覧表を参照してください。
- ・可変抵抗と半固定抵抗で、B特性の表示を省略。
- ・信号名表記について、下記のような場合があります。

XEDIT	EDIT	PB/XREC	PB/REC
-------	------	---------	--------

- ・ は不燃性抵抗。
- ・ はヒューズ抵抗。
- ・ はパネル表示名称。
- ・ はB+ライン。
- ・ はB-ライン。
- ・ はBライン (+, -) の入出力方向を示す。
- ・ は調整名称。

## 【電圧・波形測定条件ノート】

- ・電圧値及び信号波形はパターンボックスのカラーバーチャートを被写体としたときの測定点对アース間の参考値。  
(デジタルマルチメータ; 入力インピーダンス DC10M $\Omega$ 使用)
- ・使用テストの入力インピーダンスにより電圧値が多少異なります。

## イメージ交換時の注意

- ・イメージを交換した場合は、カメラ部の全調整を行ってください。
  - ・イメージは構造上、静電気により破壊される恐れがあるため、MOS ICと同様に注意して取り扱ってください。
- また、受光部にはゴミの付着、および強い光がはいることのないように注意してください。

## 1. 接続図

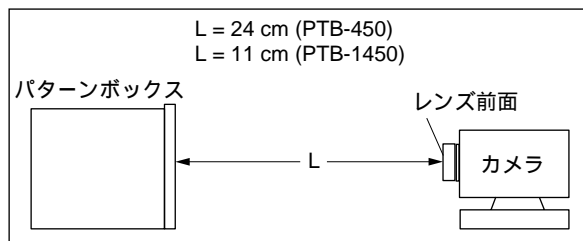
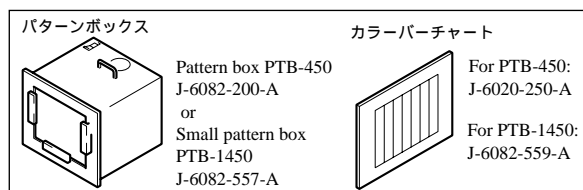

## 2. 図a及び図bの波形が得られるように画枠調整して下さい。

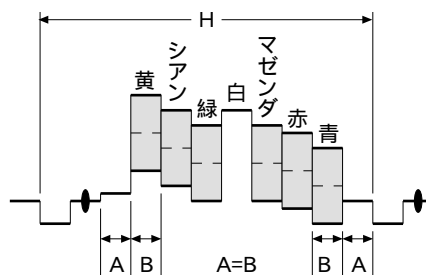

図a (映像入出力端子出力波形)

電子ビーム走査線

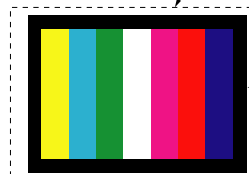

図b (テレビモニタの映像)

△印の部品、または△印付きの点線で囲まれた部品は、安全性を維持するために重要な部品です。従って交換時は、必ず指定の部品を使用して下さい。

## お願い

図面番号で部品を指定するときは基板名又はブロックを併せて指定して下さい。

Schematic diagrams of the CD-743 flexible board and SY-207 board are not shown.  
Pages from 4-4 to 4-13 are not shown.

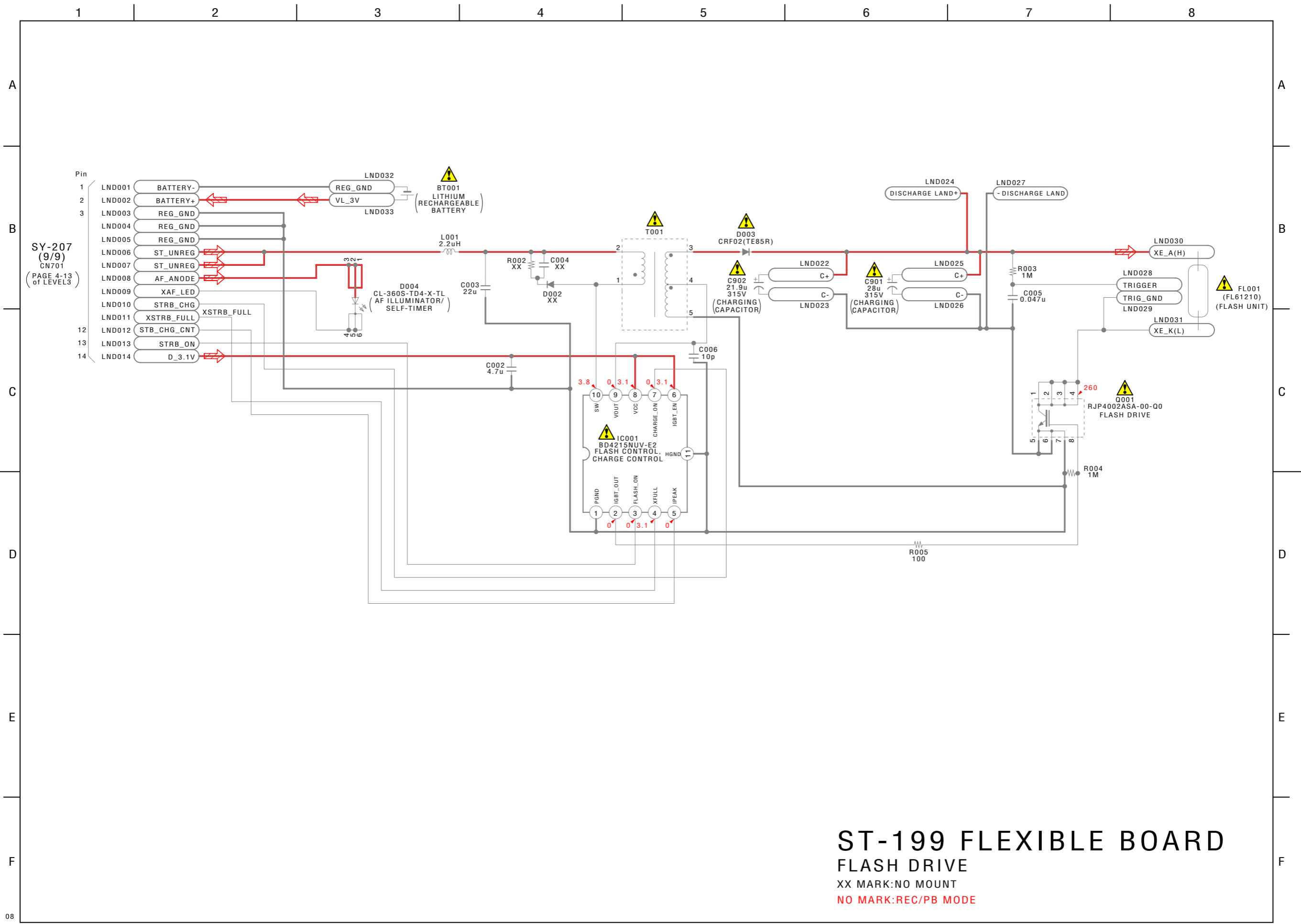

# ST-199 FLEXIBLE BOARD

## FLASH DRIVE

XX MARK:NO MOUNT

NO MARK:REC/PB MODE

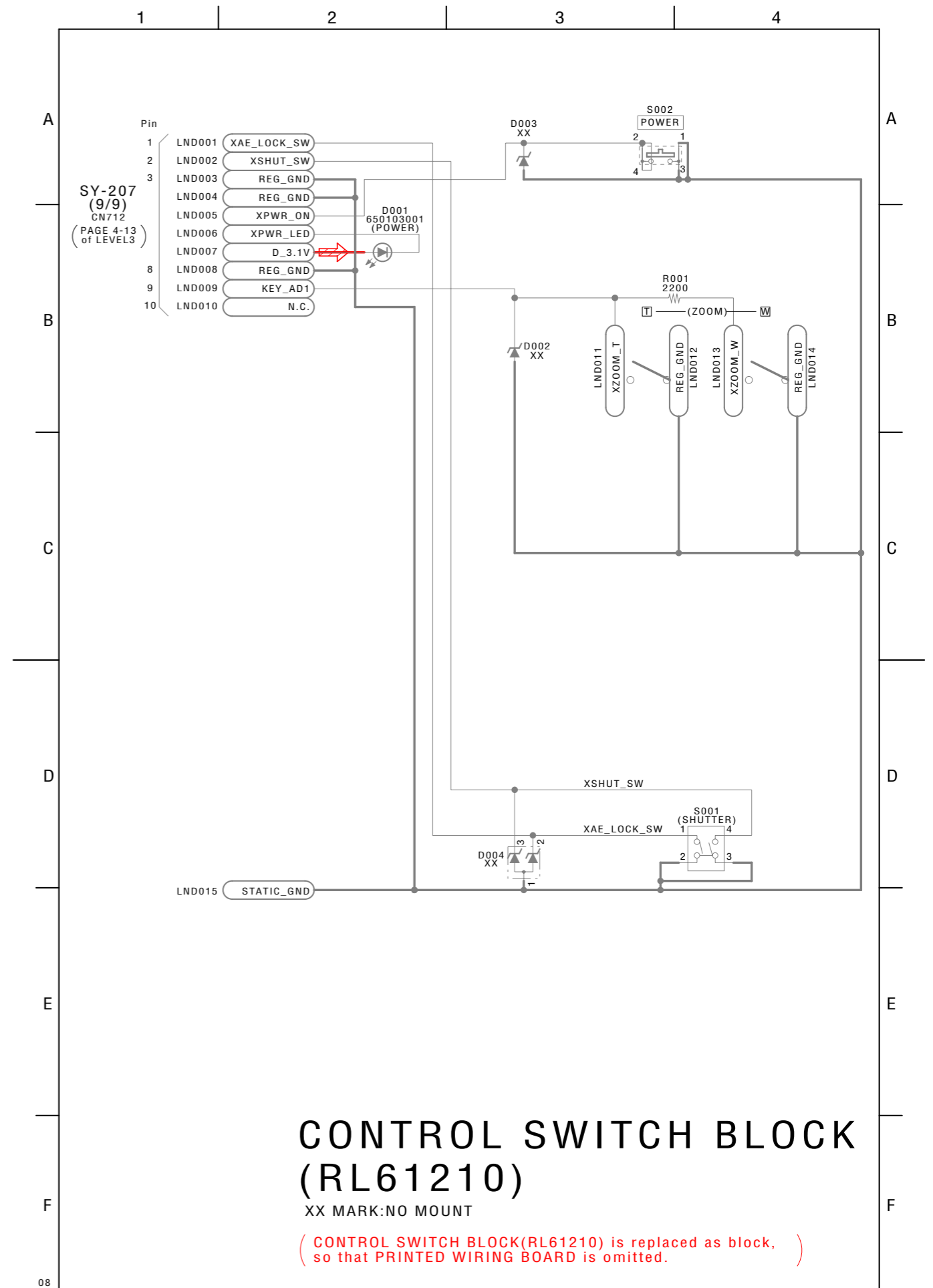
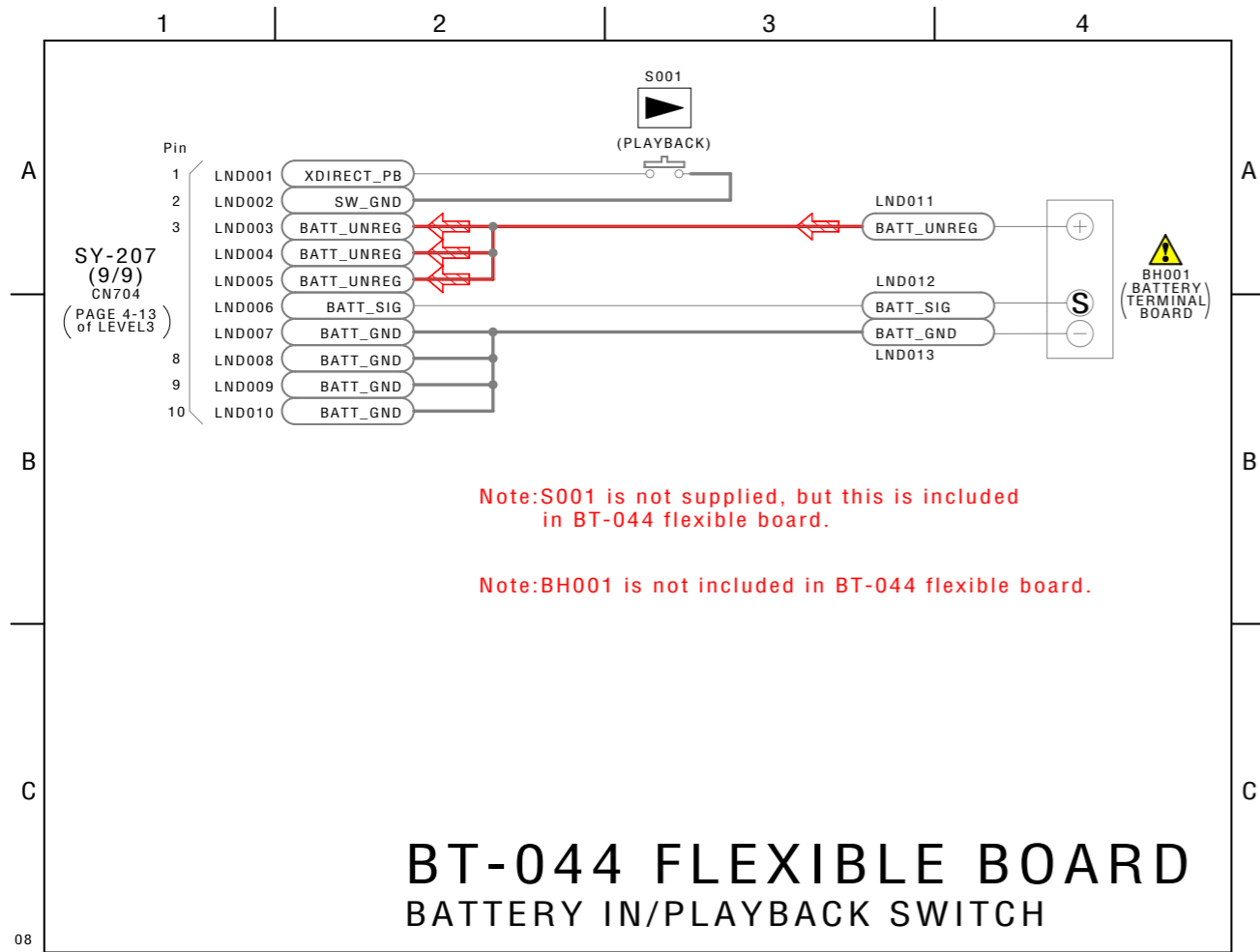

## 4-3. PRINTED WIRING BOARDS

### Link

• [ST-199 FLEXIBLE BOARD](#)

• [BT-044 FLEXIBLE BOARD](#)







• [COMMON NOTE FOR PRINTED WIRING BOARDS](#)

# 4-3. PRINTED WIRING BOARDS

## 4-3. PRINTED WIRING BOARDS

### (ENGLISH)

#### THIS NOTE IS COMMON FOR PRINTED WIRING BOARDS

-  : Uses unleaded solder.
-  : Circuit board
-  : Flexible board
-  : Pattern from the side which enables seeing.
-  : pattern of the rear side  
(The other layers' patterns are not indicated)
- Through hole is omitted.
- Circled numbers refer to waveforms.
- There are a few cases that the part printed on diagram isn't mounted in this model.
-  : panel designation

- Chip parts.

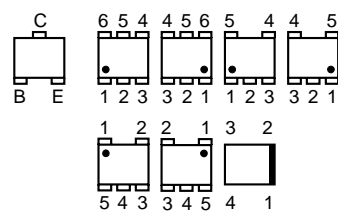



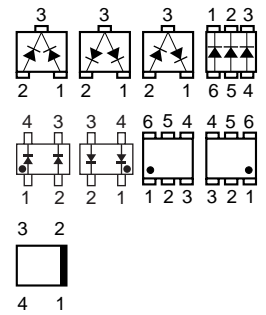



#### Diode



### (JAPANESE)

#### プリント図共通ノート

#### 【プリント図ノート】

-  : 無鉛半田を使用しています。
-  : 基板
-  : フレキシブル配線板
-  : 見ている面側のパターン。
-  : 裏側のパターン  
(他のパターンについては表示されていません)
- スルーホールは省略。
- プリント図には、本機で使用していない部品が記載されている場合があります。
-  はパネル表示名称。

Printed wiring boards of the CD-743 flexible board and SY-207 board are not shown.  
Pages from 4-17 to 4-19 are not shown.

 : Uses unleaded solder.

### ST-199 FLEXIBLE BOARD

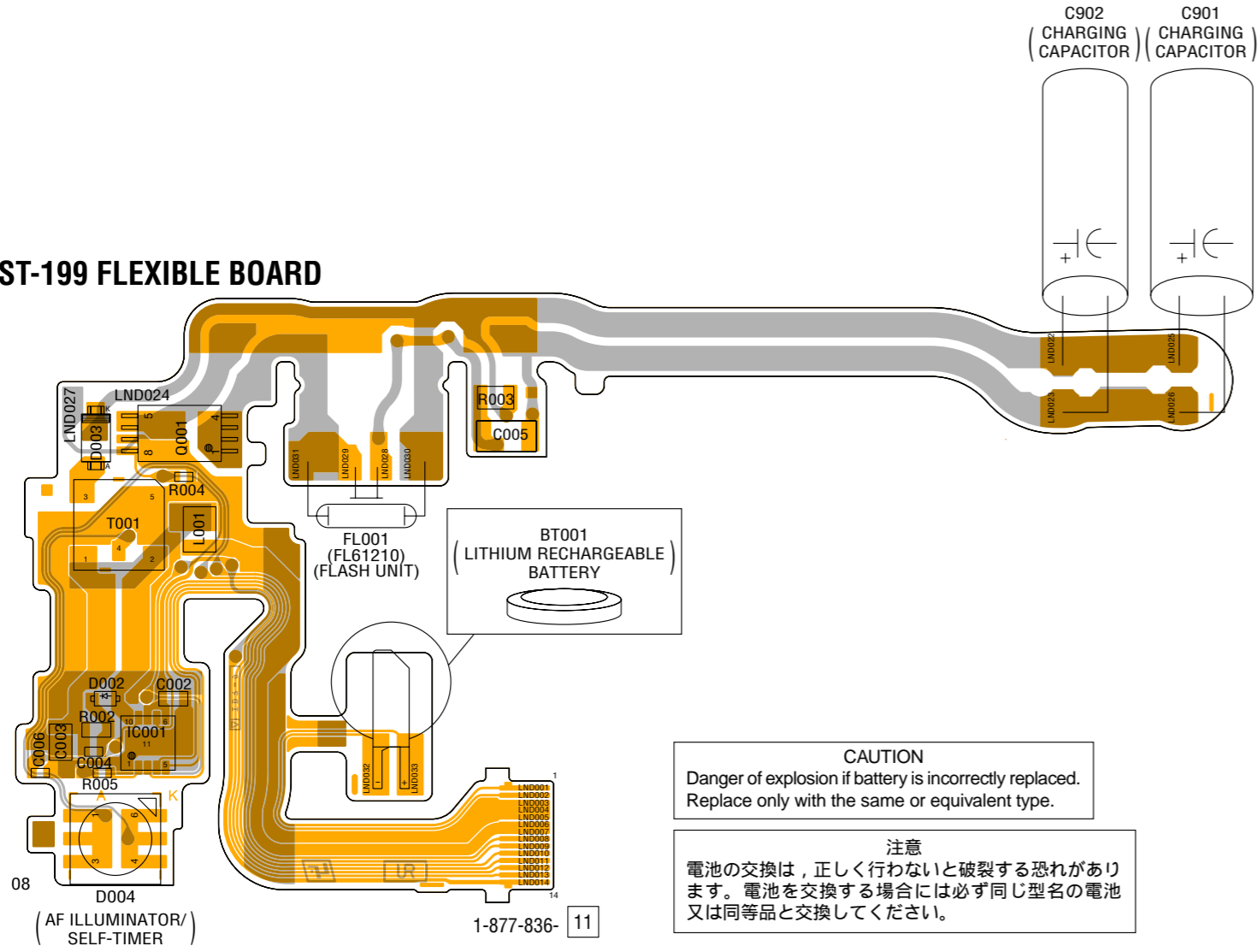

**CAUTION**  
 Danger of explosion if battery is incorrectly replaced.  
 Replace only with the same or equivalent type.

**注意**  
 電池の交換は、正しく行わないと破裂する恐れがあります。  
 電池を交換する場合には必ず同じ型名の電池  
 又は同等品と交換してください。

### BT-044 FLEXIBLE BOARD

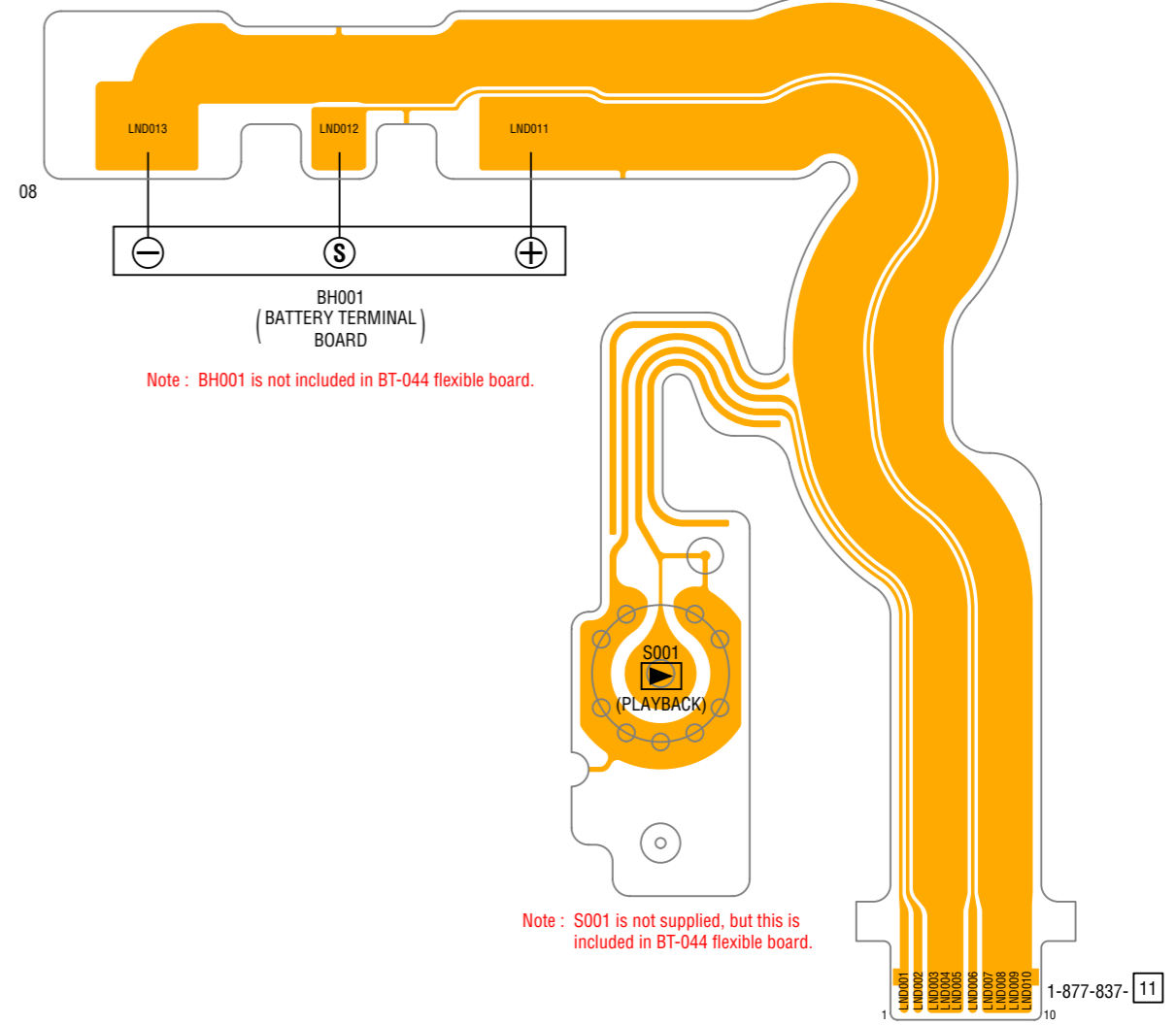

Note : BH001 is not included in BT-044 flexible board.

Note : S001 is not supplied, but this is included in BT-044 flexible board.

# 5. REPAIR PARTS LIST

NOTE: Characters **A** to **Z** of the electrical parts list indicate location of exploded views in which the desired part is shown.

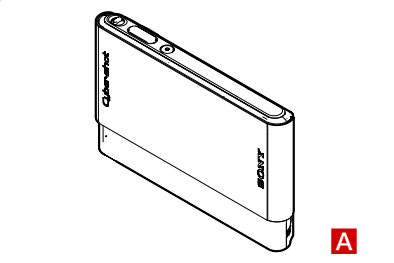
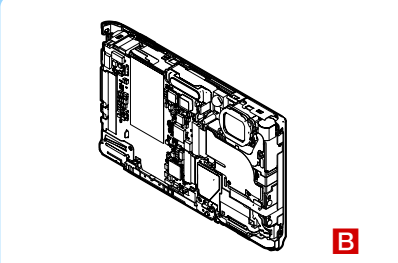
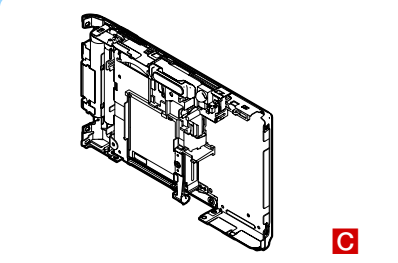
Link	EXPLODED VIEWS		
			
<a href="#">OVERALL SECTION</a>	<a href="#">MAIN SECTION</a>	<a href="#">ST/REAR SECTION</a>	

Link	ELECTRICAL PARTS LIST	ACCESSORIES
<a href="#">BT-044 FLEXIBLE BOARD</a>	<a href="#">ST-199 FLEXIBLE BOARD</a>	

# 5. REPAIR PARTS LIST

## 5. REPAIR PARTS LIST

### (ENGLISH)

**NOTE:**

- -XX, -X mean standardized parts, so they may have some differences from the original one.
- Items marked “\*” are not stocked since they are seldom required for routine service. Some delay should be anticipated when ordering these items.
- The mechanical parts with no reference number in the exploded views are not supplied.
- Due to standardization, replacements in the parts list may be different from the parts specified in the diagrams or the components used on the set.
- CAPACITORS:  
uF:  $\mu$ F
- COILS  
uH:  $\mu$ H
- RESISTORS  
All resistors are in ohms.  
METAL: metal-film resistor  
METAL OXIDE: Metal Oxide-film resistor  
F: nonflammable
- SEMICONDUCTORS  
In each case, u:  $\mu$ , for example:  
uA...:  $\mu$ A..., uPA...,  $\mu$ PA...,  
uPB...,  $\mu$ PB...,  $\mu$ PC...,  $\mu$ PC...,  
uPD...,  $\mu$ PD...

When indicating parts by reference number, please include the board name.

The components identified by mark  $\Delta$  or dotted line with mark  $\Delta$  are critical for safety. Replace only with part number specified.

Les composants identifiés par une marque  $\Delta$  sont critiques pour la sécurité. Ne les remplacer que par une pièce portant le numéro spécifié.

- Color Indication of Appearance Parts  
Example:  
(SILVER) : Cabinet's Color  
(Silver) : Parts Color

### (JAPANESE)

**【使用上の注意】**

- ここに記載されている部品は、補修用部品であるため、回路図及びセットに付いている部品と異なる場合があります。
- -XX, -Xは標準化部品のため、セットに付いている部品と異なる場合があります。
- \*印の部品は常備在庫しておりません。
- コンデンサの単位でuFは $\mu$ Fを示します。
- 抵抗の単位は省略してあります。  
金 被：金属被膜抵抗。  
サンキン：酸化金属被膜抵抗。
- インダクタの単位でuHは $\mu$ Hを示します。
- 半導体の名称でuA..., uPA..., uPB..., uPC..., uPD...等はそれぞれA...,  $\mu$ PA...,  $\mu$ PB...,  $\mu$ PC...,  $\mu$ PD...を示します。

お願い  
図面番号で部品を指定するときは基板名又はブロックを併せて指定してください。

$\Delta$ 印の部品、または $\Delta$ 印付の点線で囲まれた部品は、安全性を維持するために、重要な部品です。従って交換時は必ず指定の部品を使用してください。

- Abbreviation  
AR : Argentine model  
AUS : Australian model  
BR : Brazilian model  
CH : Chinese model  
CND : Canadian model  
EE : East European model  
HK : Hong Kong model  
J : Japanese model  
JE : Tourist model  
KR : Korea model  
NE : North European model  
TH : Thai model  
TW : Taiwan model

### THE COMBINATION OF CABINET'S COLOR AND SCREW

The screw pointed  is different according to the cabinet's color. For the combination of cabinet's color and screw, please refer to Table 5-1.

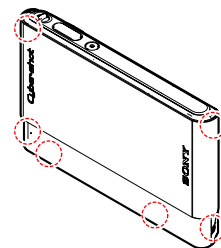

Table 5-1

Screw's Ref. No. (Parts Color.)	Cabinet's Color
#142 (Silver)	SILVER/GREEN/PINK
#143 (Black)	BLACK/BROWN

# 5. REPAIR PARTS LIST

## 5-1. EXPLODED VIEWS

DISASSEMBLY

HARDWARE LIST

### 5-1-1. OVERALL SECTION

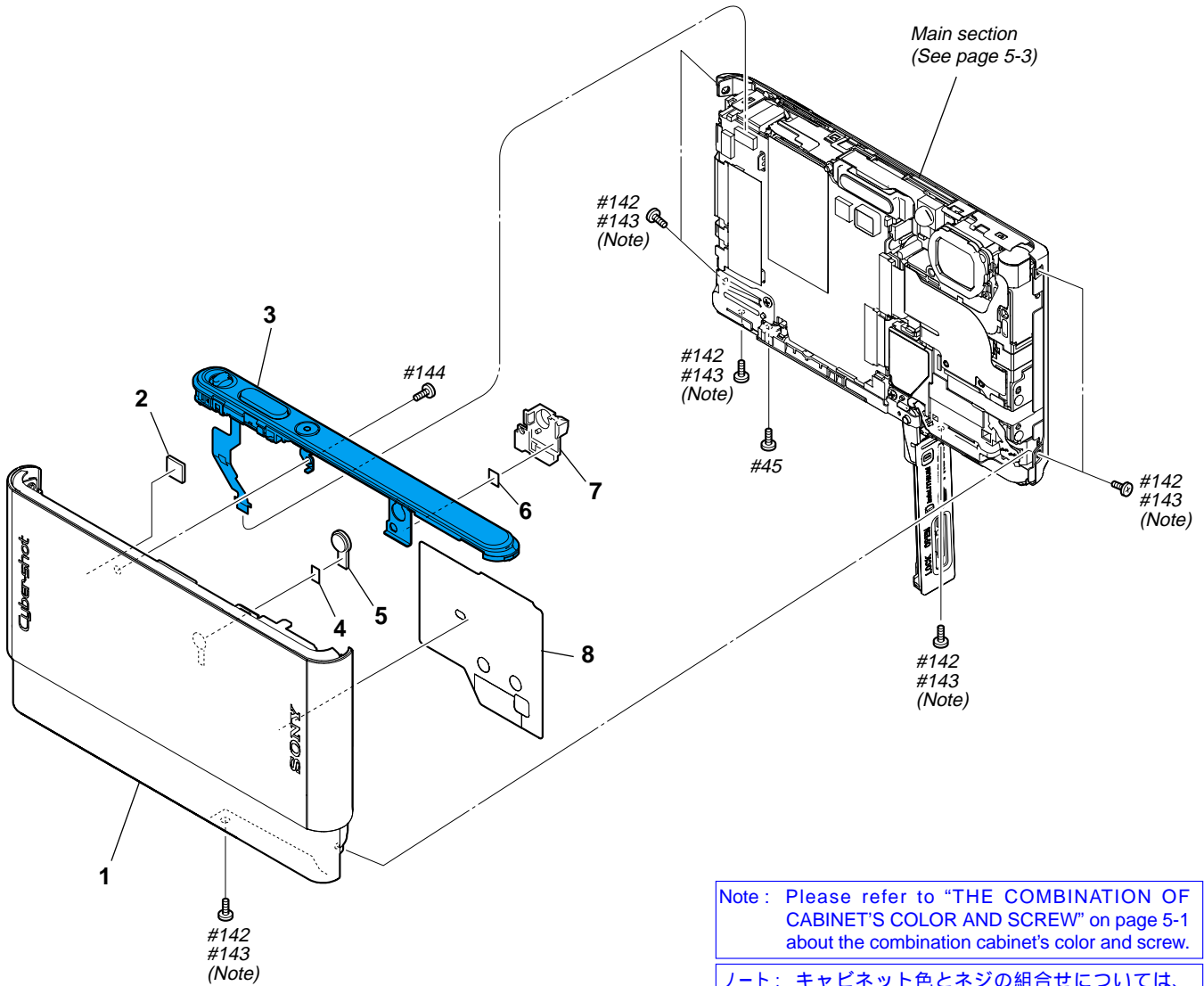

Note : Please refer to "THE COMBINATION OF CABINET'S COLOR AND SCREW" on page 5-1 about the combination cabinet's color and screw.

ノート：キャビネット色とネジの組合せについては、5-1ページの"THE COMBINATION OF CABINET'S COLOR AND SCREW"を参照してください。

Ref. No.	Part No.	Description
1	X-2319-561-1	CABINET (FRONT) ASSY (SILVER)
1	X-2319-562-1	CABINET (FRONT) ASSY (BLACK)
1	X-2319-563-1	CABINET (FRONT) ASSY (BROWN)
1	X-2319-564-1	CABINET (FRONT) ASSY (PINK)
1	X-2319-565-1	CABINET (FRONT) ASSY (GREEN)
* 2	4-111-400-01	CUSHION, FRONT
3	1-480-871-11	SWITCH BLOCK, CONTROL (RL61210) (GREEN/SILVER)
3	1-480-871-22	SWITCH BLOCK, CONTROL (RL61210) (BLACK)
3	1-480-871-32	SWITCH BLOCK, CONTROL (RL61210) (BROWN)

Ref. No.	Part No.	Description
3	1-480-871-42	SWITCH BLOCK, CONTROL (RL61210) (PINK)
4	4-111-393-01	SHEET, AF WINDOW ADHESIVE
5	4-111-370-01	WINDOW, AF
* 6	4-111-399-01	SHEET, PLAY BUTTON ADHESIVE
7	4-111-394-01	HOLDER, AF WINDOW
8	4-111-395-01	SHEET, LENS FLEXIBLE PROTECTION
#45	2-587-151-01	SCREW (M1.4), NEW, TRUSTAR, P2 (Silver)
#142	4-111-392-01	HEAD (NEW TORASUTA) M1.4 (Silver) (Note)
#143	4-111-392-11	HEAD (NEW TORASUTA) M1.4 (Black) (Note)
#144	4-111-392-21	HEAD (NEW TORASUTA) M1.4 (Silver)

# 5. REPAIR PARTS LIST

## DISASSEMBLY

## HARDWARE LIST

### 5-1-2. MAIN SECTION

ns: not supplied

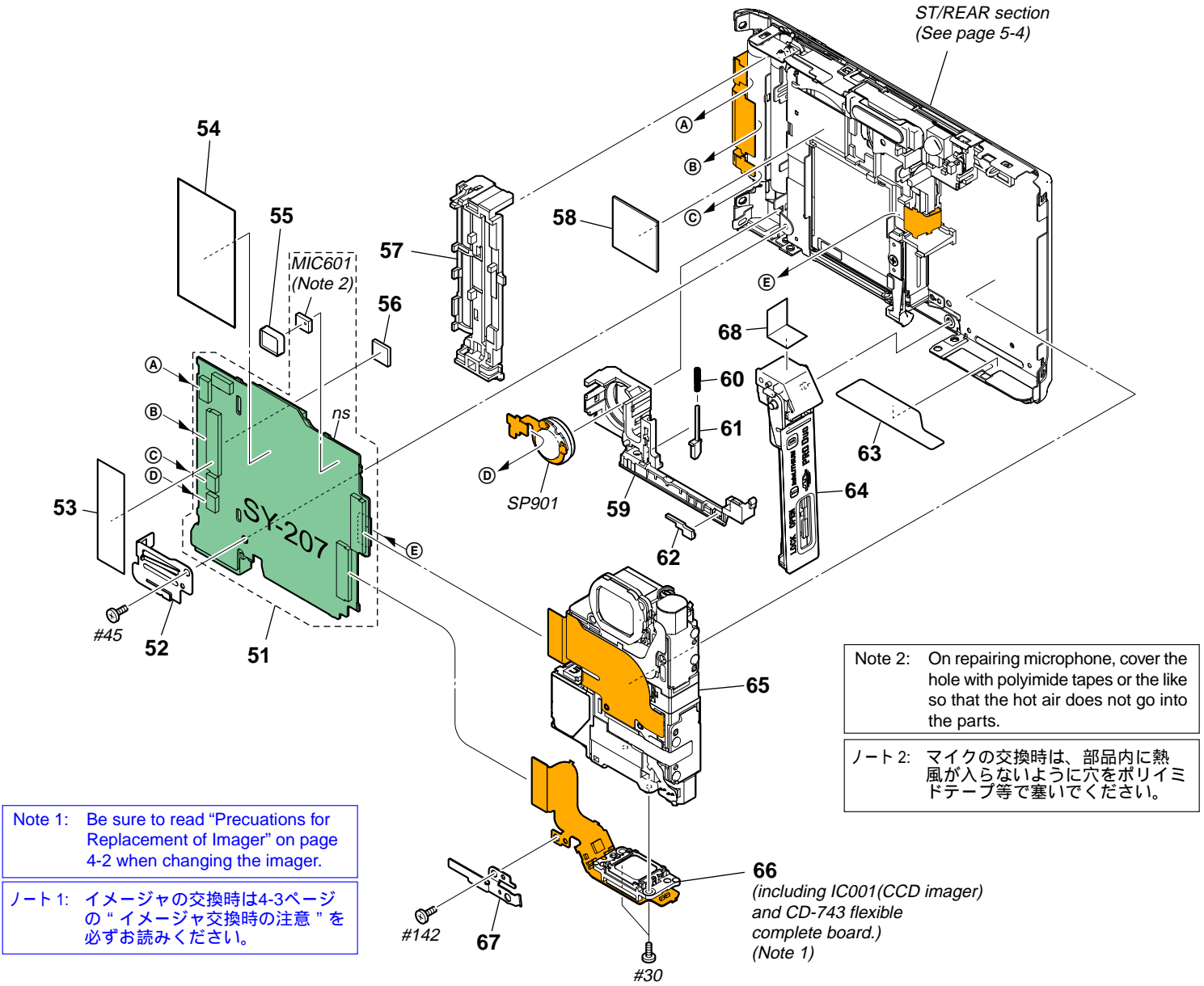

**Note 1:** Be sure to read "Precautions for Replacement of Imager" on page 4-2 when changing the imager.

**ノート 1:** イメージャの交換時は4-3ページの「イメージャ交換時の注意」を必ずお読みください。

**Note 2:** On repairing microphone, cover the hole with polyimide tapes or the like so that the hot air does not go into the parts.

**ノート 2:** マイクの交換時は、部品内に熱風が入らないように穴をポリイミドテープ等で塞いでください。

Ref. No.	Part No.	Description
51	A-1557-174-A	SY-207 BOARD, COMPLETE (SERVICE)
* 52	4-111-385-01	PLATE, MULTI FIXED
* 53	4-111-396-01	SHEET (A), INSULATING
54	4-111-390-01	SHEET, SY INSULATING
55	4-111-391-01	HOLDER, MICROPHONE
* 56	4-111-400-01	CUSHION, FRONT
* 57	4-111-379-01	HOLDER, SY
* 58	4-111-401-01	CUSHION, REAR
59	4-111-381-01	BASE, BT LID (SILVER)
59	4-111-381-11	BASE, BT LID (BLACK)
59	4-111-381-21	BASE, BT LID (BROWN)
59	4-111-381-31	BASE, BT LID (PINK)
59	4-111-381-41	BASE, BT LID (GREEN)
60	4-111-374-01	SPRING, BT LID (PUSH OUT)
61	4-111-375-01	LID (PUSH OUT LOD), BT
62	4-111-382-01	LIGHT, MS GUIDE,
* 63	4-111-388-01	SHEET, CD LIGHT INTERCEPTION

Ref. No.	Part No.	Description
64	X-2319-579-1	LID ASSY (SILVER) (210), BT (SILVER)
64	X-2319-580-1	LID ASSY (BLACK) (210), BT (BLACK)
64	X-2319-581-1	LID ASSY (BROWN) (210), BT (BROWN)
64	X-2319-582-1	LID ASSY (PINK) (210), BT (PINK)
64	X-2319-583-1	LID ASSY (GREEN), BT (GREEN)
65	A-1553-310-A	LSV-1300A (SERVICE USE)
66	A-1558-183-A	CCD BLOCK ASSY (SERVICE) (including IC001 (CCD imager) and CD-743 flexible complete board.) (Note 1)
* 67	4-111-383-01	PLATE, BT LID CLICK
* 68	4-120-996-01	SHEET (K), RADIATION
MIC601	1-542-756-21	MICROPHONE (Note 2)
SP901	1-826-403-81	LOUDSPEAKER (1.0CM)
#30	3-086-156-11	SCREW B1.2 (White)
#45	2-587-151-01	SCREW (M1.4), NEW, TRUSTAR, P2 (Silver)
#142	4-111-392-01	HEAD (NEW TORASUTA) M1.4 (Silver)

# 5. REPAIR PARTS LIST

## DISASSEMBLY

## HARDWARE LIST

### 5-1-3. ST/REAR SECTION

ns: not supplied

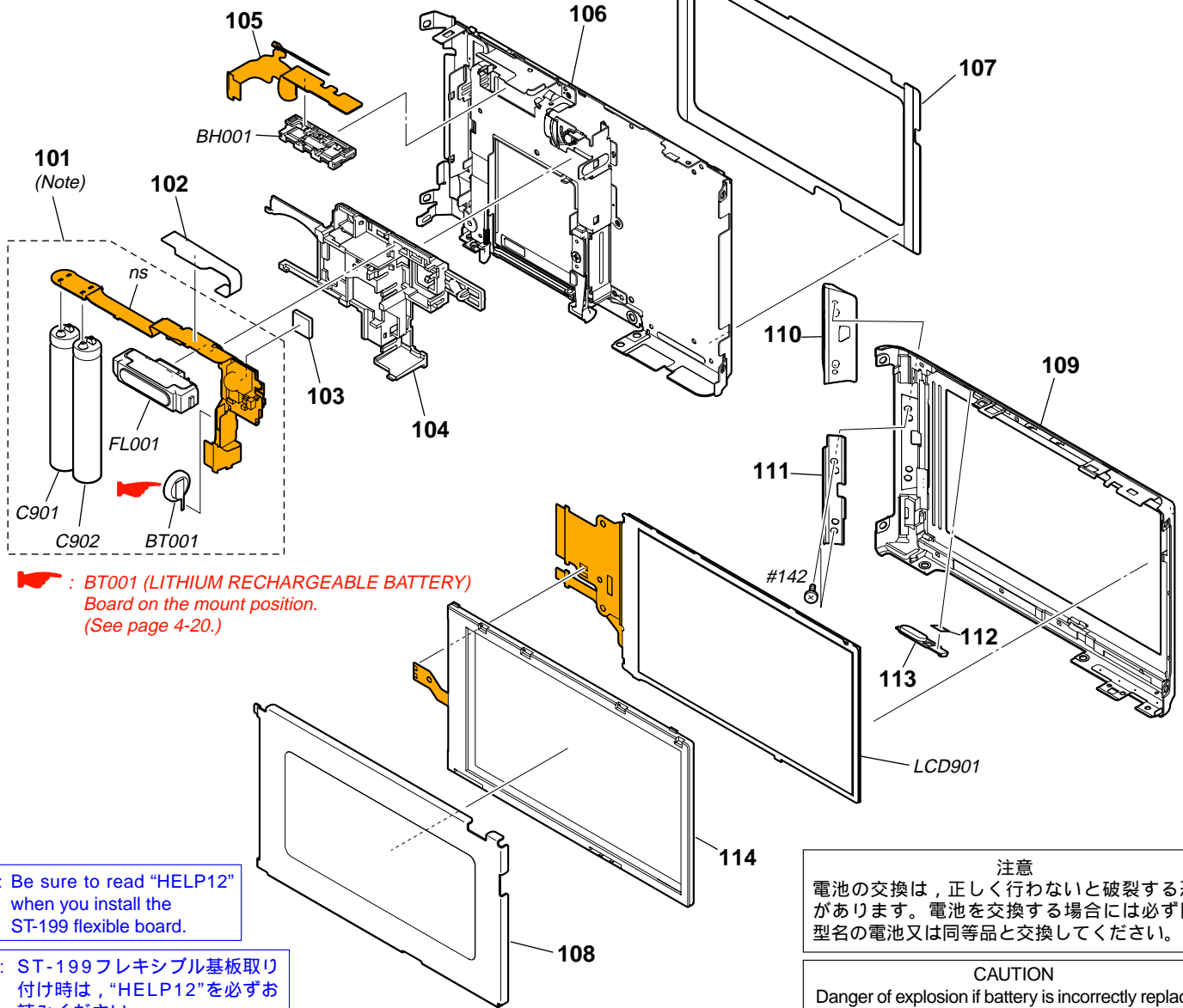

Note: Be sure to read "HELP12" when you install the ST-199 flexible board.

ノート: ST-199フレキシブル基板取り付け時は, "HELP12"を必ずお読みください。

注意

電池の交換は, 正しく行わないと破裂する恐れがあります。電池を交換する場合には必ず同じ型名の電池又は同等品と交換してください。

CAUTION

Danger of explosion if battery is incorrectly replaced.  
Replace only with the same or equivalent type.

• Refer to page 5-1 for mark △.

Ref. No.	Part No.	Description
101	A-1557-173-A	ST-199 FLEXIBLE BOARD, COMPLETE (Note)
* 102	4-111-398-01	CUSHION, ST
103	4-111-387-01	CUSHION, AF
* 104	4-111-380-01	HOLDER, ST
105	1-877-837-11	BT-044 FLEXIBLE BOARD
106	X-2319-578-1	FRAME ASSY (210)
107	4-111-386-01	CUSHION, LCD
* 108	4-111-384-01	FRAME, BL
109	A-1562-515-A	CABINET REAR BLOCK (SERVICE) (SILVER)
109	A-1562-523-A	CABINET REAR BLOCK (SERVICE) (BLACK)
109	A-1562-524-A	CABINET REAR BLOCK (SERVICE) (BROWN)
109	A-1562-525-A	CABINET REAR BLOCK (SERVICE) (PINK)
109	A-1562-526-A	CABINET REAR BLOCK (SERVICE) (GREEN)
110	4-111-371-01	BRACKET, STRAP (GREEN/SILVER)
110	4-111-371-11	BRACKET, STRAP (BLACK)

Ref. No.	Part No.	Description
110	4-111-371-21	BRACKET, STRAP (BROWN)
110	4-111-371-31	BRACKET, STRAP (PINK)
111	4-111-373-01	PLATE (G), REAR
* 112	4-111-399-01	SHEET, PLAY BUTTON ADHESIVE
113	4-111-372-01	BUTTON, PLAY (SILVER)
113	4-111-372-11	BUTTON, PLAY (BLACK)
113	4-111-372-21	BUTTON, PLAY (BROWN)
113	4-111-372-31	BUTTON, PLAY (PINK)
113	4-111-372-41	BUTTON, PLAY (GREEN)
114	1-480-913-11	BLOCK, LIGHT GUIDE PLATE (3.0)
△ BH001	1-780-651-11	TERMINAL BOARD, BATTERY
△ BT001	1-756-813-11	LITHIUM RECHARGEABLE BATTERY
△*C901	1-114-874-11	ELECT 28uF 99% 315V
△*C902	1-114-873-11	ELECT 21.9uF 99% 315V
△ FL001	1-480-964-11	FLASH UNIT (FL61210)
LCD901	A-1551-533-A	FTS BLOCK ASSY (30SHGU08)
#142	4-111-392-01	HEAD (NEW TORASUTA) M1.4 (Silver)

**5-2. ELECTRICAL PARTS LIST**

<u>Ref. No.</u>	<u>Part No.</u>	<u>Description</u>
	1-877-837-11	BT-044 FLEXIBLE BOARD *****

(BH001 is not included in BT-044 flexible board.)

(S001 is not supplied, but this is included in BT-044 flexible board.)

< BATTERY TERMINAL BOARD >

△ BH001 1-780-651-11 TERMINAL BOARD, BATTERY

< SWITCH >

S001 (Not supplied) SWITCH (PLAYBACK)

(S001 is supplied including in BT-044 flexible board.)

Electrical parts list of the CD-743 flexible board is not shown.  
Pages 5-6 is not shown.

• Refer to page 5-1 for mark △.

Ref. No.	Part No.	Description
	A-1557-173-A	ST-199 FLEXIBLE BOARD, COMPLETE *****
		< LITHIUM RECHARGEABLE BATTERY >
△ BT001	1-756-813-11	LITHIUM RECHARGEABLE BATTERY
		< CAPACITOR >
* C002	1-112-746-11	CERAMIC CHIP 4.7uF 10% 6.3V
C003	1-100-611-91	CERAMIC CHIP 22uF 20% 6.3V
C005	1-100-758-11	CERAMIC CHIP 0.047uF 10% 250V
C006	1-164-850-11	CERAMIC CHIP 10PF 0.5PF 50V
△*C901	1-114-874-11	ELECT 28uF 99% 315V
△*C902	1-114-873-11	ELECT 21.9uF 99% 315V
		< DIODE >
△ D003	6-501-096-01	DIODE CRF02 (TE85R)
* D004	6-501-861-01	DIODE CL-360S-TD4-X-TL (AF ILLUMINATOR/SELF-TIMER)
		< FLASH >
△ FL001	1-480-964-11	FLASH UNIT (FL61210)
		< IC >
△*IC001	6-712-975-01	IC BD4215NUV-E2
		< COIL >
* L001	1-400-820-11	INDUCTOR 2.2uH
		< TRANSISTOR >
△*Q001	6-551-922-01	TRANSISTOR RJP4002ASA-00-Q0
		< RESISTOR >
R003	1-216-121-00	METAL CHIP 1M 5% 1/10W
R004	1-218-989-11	RES-CHIP 1M 5% 1/16W
R005	1-218-941-11	RES-CHIP 100 5% 1/16W
		< TRANSFORMER >
△*T001	1-445-491-21	D.C.-D.C.CONVERTER TRANSFORMER

Electrical parts list of the SY-207 board is not shown.  
Pages 5-8 to 5-11 are not shown.

CAUTION

Danger of explosion if battery is incorrectly replaced.  
Replace only with the same or equivalent type.

注意

電池の交換は、正しく行わないと破裂する恐れがあります。電池を交換する場合には必ず同じ型名の電池又は同等品と交換してください。

• Refer to page 5-1 for mark △.

## Checking supplied accessories.

Note 1: This item is supplied with the unit as an accessory, but is not prepared as a service part.

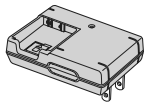

Battery charger  
(BC-CSD)

- △ 1-480-352-12 (J)
- △ 1-480-352-22 (US, CND)

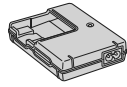

Battery charger  
(BC-CSD)

- △ 1-480-352-32  
(EXCEPT US, CND, J)



Power cord (mains lead)  
(EXCEPT US, CND, J)

- △ 1-555-074-91 (AUS)
- △ 1-783-952-61 (AR)
- △ 1-792-549-41 (JE)
- △ 1-824-910-71 (AEP, E)
- △ 1-827-269-12 (UK, HK)
- △ 1-832-121-31 (CH)
- △ 1-833-892-21 (KR)
- △ 1-835-434-11 (TH)

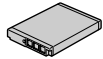

Rechargeable battery pack  
(NP-BD1)

- △ A-1310-294-A (J)
- △ A-1310-295-A (US, CND)
- △ A-1310-296-B (EXCEPT US, CND, CH, J)
- △ A-1310-297-A (CH)



Conversion (2P) Adaptor

- △ 1-569-008-12  
(E (Except Middle East))



Instruction Manual

- 4-000-949-01 (JAPANESE) (J)
- 4-000-949-11 (ENGLISH) (CND, AEP, UK, E, HK, TH, AUS, JE)
- 4-000-949-21 (FRENCH, ITALIAN) (CND, AEP)
- 4-000-949-31 (SPANISH, PORTUGUESE) (AEP, E, AR, JE)
- 4-000-949-41 (GERMAN, DUTCH) (AEP)
- 4-000-949-51 (TRADITIONAL CHINESE, SIMPLIFIED CHINESE) (HK, E, JE)
- 4-000-949-61 (RUSSIAN, UKRAINIAN) (AEP)
- 4-000-949-71 (ARABIC, PERSIAN) (E)
- 4-000-949-81 (KOREAN) (KR, JE)
- 4-000-949-91 (POLISH, CZECH) (AEP)
- 4-000-950-11 (HUNGARIAN, SLOVAK) (AEP)
- 4-000-950-21 (SWEDISH, FINNISH) (AEP)
- 4-000-950-31 (NORWEGIAN, DANISH) (AEP)
- 4-000-950-41 (MALAY) (E)
- 4-000-950-51 (TURKISH, GREEK) (AEP)
- 4-000-950-61 (ENGLISH, SPANISH) (US)
- 4-000-950-71 (SIMPLIFIED CHINESE) (CH)
- 4-000-950-81 (THAI) (TH)

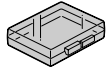

Battery case  
(Note 1)



Conversion (2P) Adaptor

- △ 1-569-007-12 (JE)

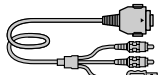

USB, A/V cable for  
multi-use terminal  
1-835-875-11



Wrist strap  
2-050-981-01 (Gray)  
(GREEN, PINK, SILVER Models)  
2-050-981-11 (Black)  
(BLACK, BROWN Models)

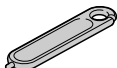

Paint pen  
2-888-952-01 (Black)  
(BLACK, BROWN Models)  
2-888-952-11 (Gray)  
(GREEN, PINK, SILVER Models)

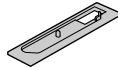

Station plate (F)  
4-114-582-01



Cyber-shot Handbook (PDF)

The CD-ROM supplied contains all of language version of the Instruction Manual in pdf (Cyber-shot Handbook.pdf) for printing.

- The printed matter is not supplied. If required, please order it with the part number below.

- (Only for destination Japanese model)  
日本国内については日本語のみが印刷での部品供給可能です。

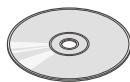

CD-ROM  
(Cyber-shot application software /  
"Cyber-shot Handbook" /  
"Cyber-shot Step-up Guide")  
4-000-945-01

- |                                      |                            |
|--------------------------------------|----------------------------|
| * 4-000-946-01 (JAPANESE)            | * 4-000-947-51 (POLISH)    |
| * 4-000-946-11 (ENGLISH)             | * 4-000-947-61 (CZECH)     |
| * 4-000-946-21 (FRENCH)              | * 4-000-947-71 (HUNGARIAN) |
| * 4-000-946-31 (ITALIAN)             | * 4-000-947-81 (SLOVAK)    |
| * 4-000-946-41 (SPANISH)             | * 4-000-947-91 (SWEDISH)   |
| * 4-000-946-51 (PORTUGUESE)          | * 4-000-948-11 (FINNISH)   |
| * 4-000-946-61 (GERMAN)              | * 4-000-948-21 (NORWEGIAN) |
| * 4-000-946-71 (DUTCH)               | * 4-000-948-31 (DANISH)    |
| * 4-000-946-81 (TRADITIONAL CHINESE) | * 4-000-948-41 (THAI)      |
| * 4-000-946-91 (SIMPLIFIED CHINESE)  | * 4-000-948-51 (MALAY)     |
| * 4-000-947-11 (RUSSIAN)             | * 4-000-948-61 (TURKISH)   |
| * 4-000-947-21 (ARABIC)              | * 4-000-948-71 (GREEK)     |
| * 4-000-947-31 (PERSIAN)             | * 4-000-948-81 (UKRAINIAN) |
| * 4-000-947-41 (KOREAN)              |                            |

• Refer to page 5-1 for mark △.

## HARDWARE LIST (1/8)

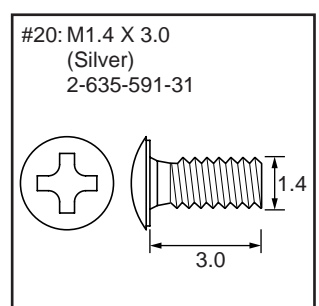
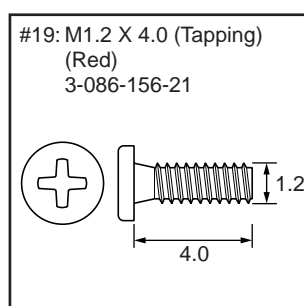
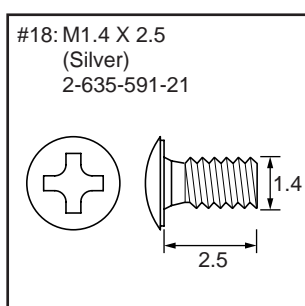
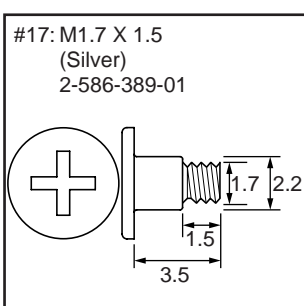
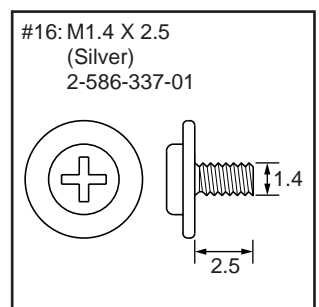
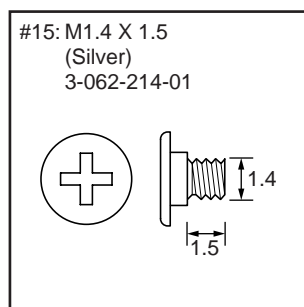
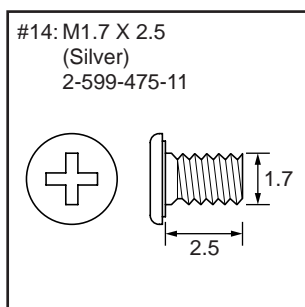
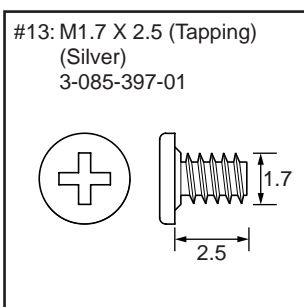
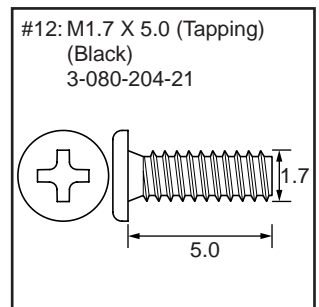
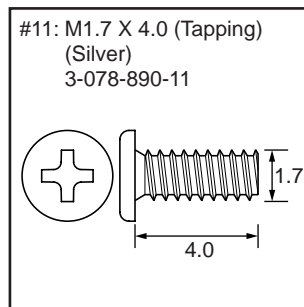
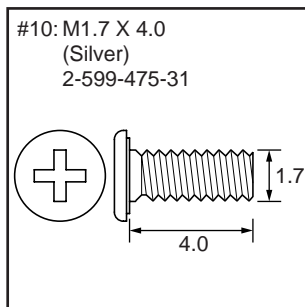
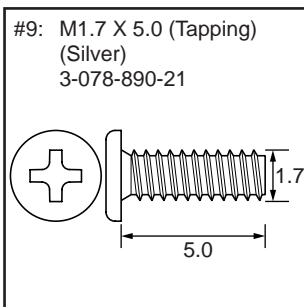
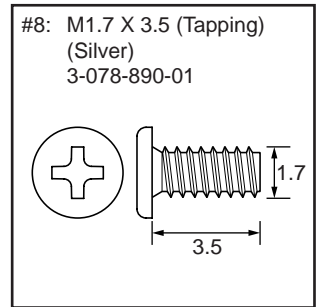
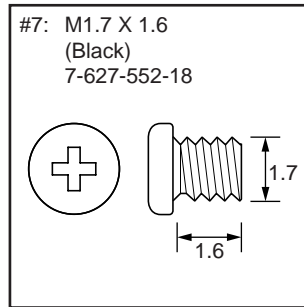
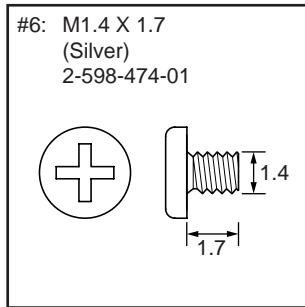
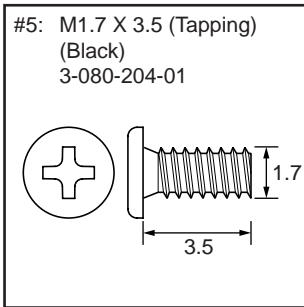
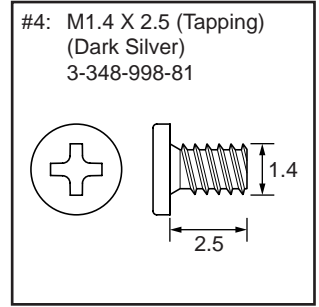
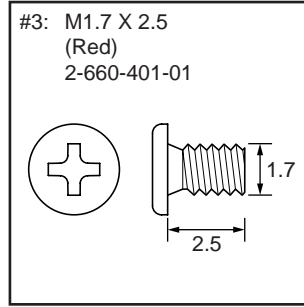
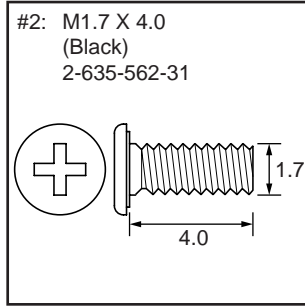
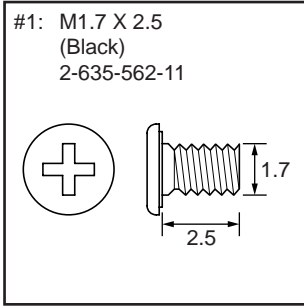

## HARDWARE LIST (2/8)

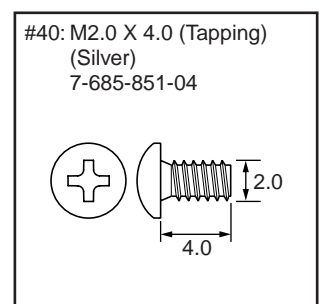
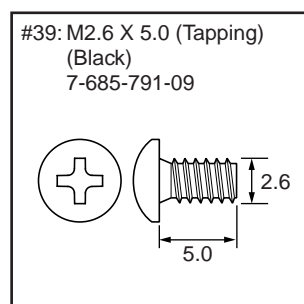
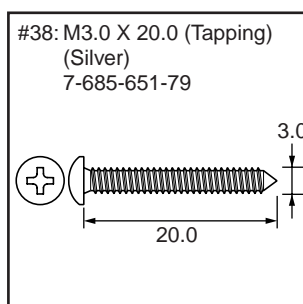
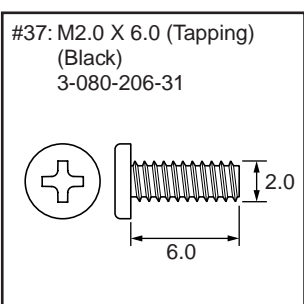
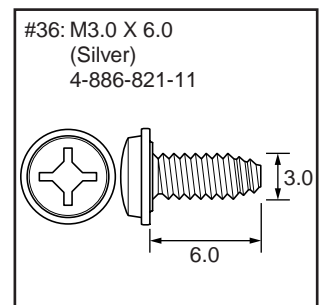
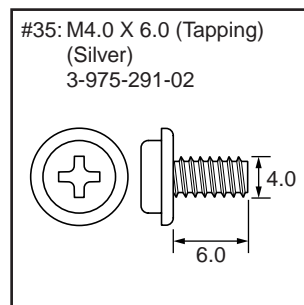
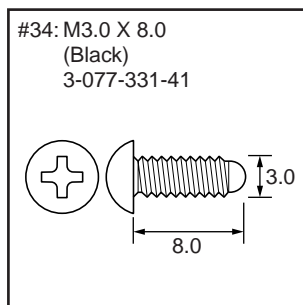
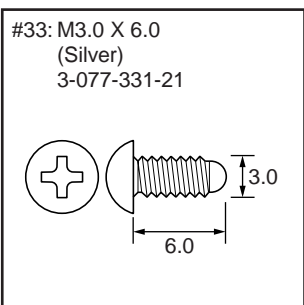
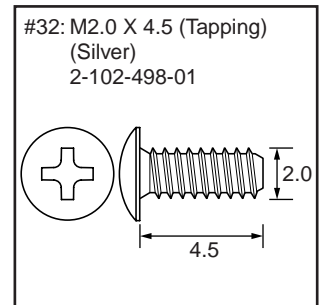
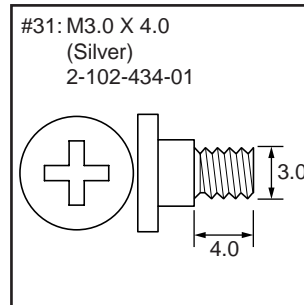
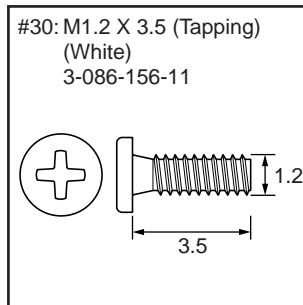
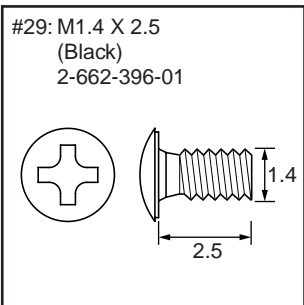
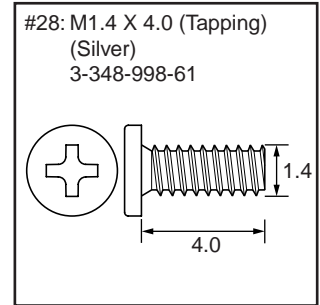
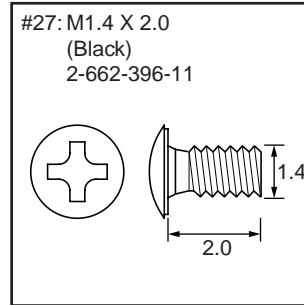
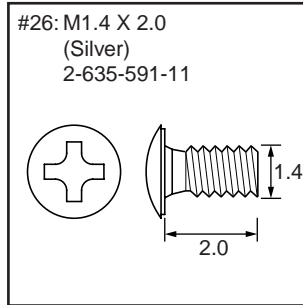
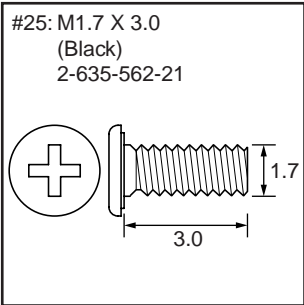
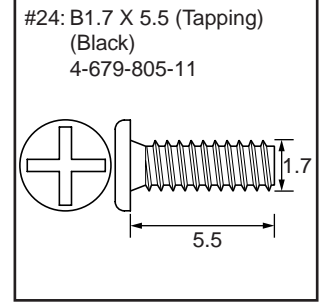
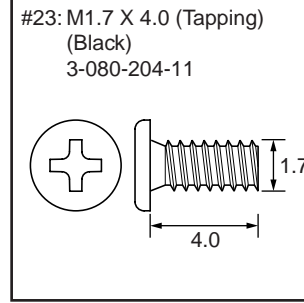
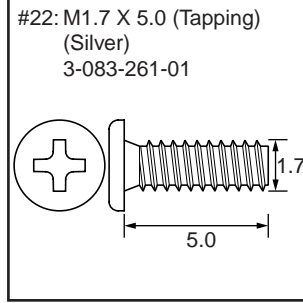
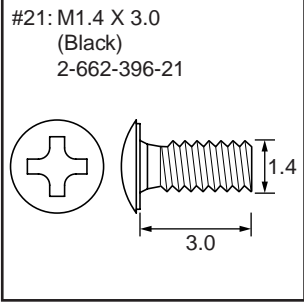

## HARDWARE LIST (3/8)

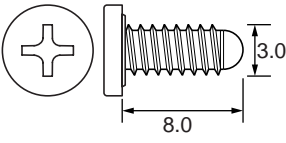
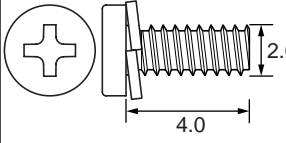
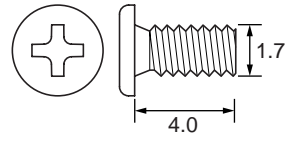
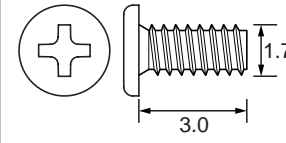
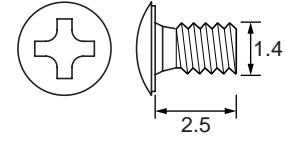
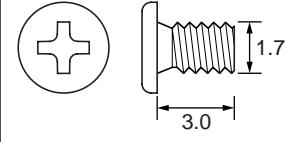
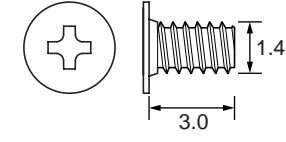
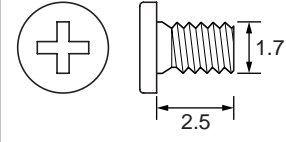
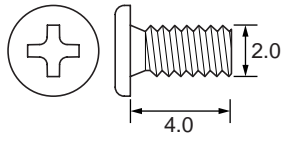
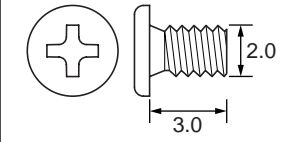
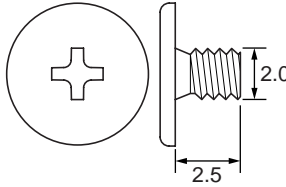
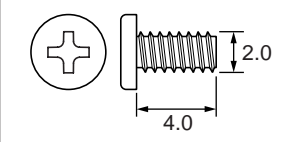
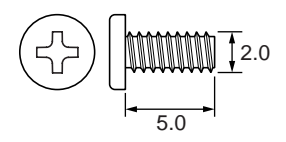
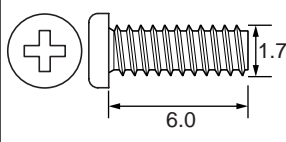
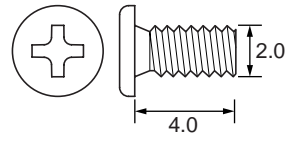
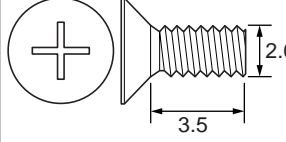
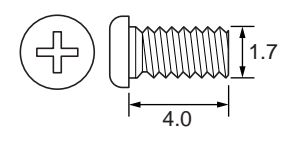
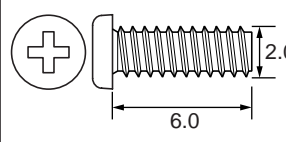
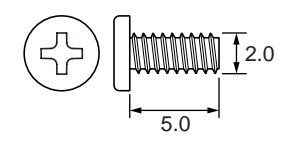
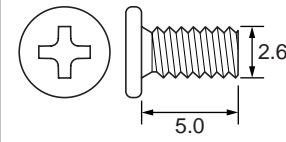
<p>#41: M3.0 X 8.0 (Tapping) (Silver) 3-065-748-01</p> 	<p>#42: M2.0 X 4.0 (Tapping) (Silver) 7-628-253-00</p> 	<p>#43: M1.7 X 4.0 (Red) 2-660-401-31</p> 	<p>#44: M1.7 X 3.0 (Tapping) (Silver) 3-078-890-61</p> 
<p>#45: M1.4 X 2.5 (Silver) 2-587-151-01</p> 	<p>#46: M1.7 X 3.0 (Red) 2-660-401-11</p> 	<p>#47: M1.4 X 3.0 (Tapping) (Silver) 2-665-774-01</p> 	<p>#48: M1.7 X 2.5 (Silver) 3-973-497-91</p> 
<p>#49: M2.0 X 4.0 (Black) 2-630-005-31</p> 	<p>#50: M2.0 X 3.0 (Red) 2-891-494-11</p> 	<p>#51: M2.0 X 2.5 (Silver) 3-073-686-01</p> 	<p>#52: M2.0 X 4.0 (Tapping) (Black) 3-080-206-11</p> 
<p>#53: M2.0 X 5.0 (Tapping) (Black) 3-080-206-21</p> 	<p>#54: M1.75 X 6.0 (Tapping) (Black) 3-318-203-11</p> 	<p>#55: M2.0 X 4.0 (Silver) 2-655-582-11</p> 	<p>#56: M2.0 X 3.5 (Silver) 3-067-187-11</p> 
<p>#57: M1.7 X 4.0 (Black) 7-627-852-18</p> 	<p>#58: M2.0 X 6.0 (Tapping) (Silver) 3-719-408-11</p> 	<p>#59: M2.0 X 5.0 (Tapping) (Silver) 3-080-205-21</p> 	<p>#60: M2.6 X 5.0 (Black) 3-061-062-11</p> 

## HARDWARE LIST (4/8)

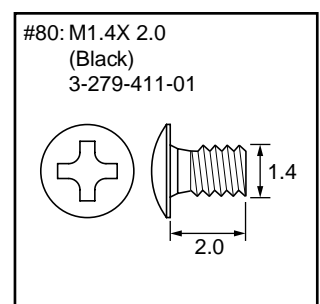
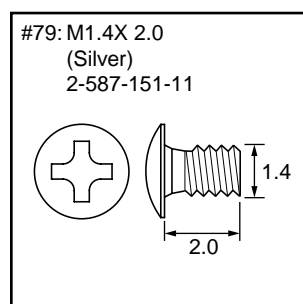
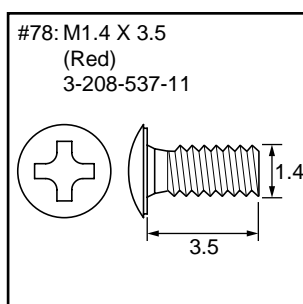
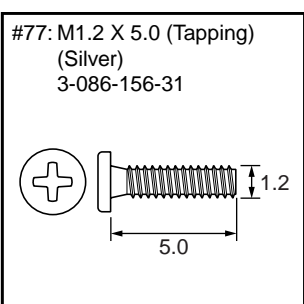
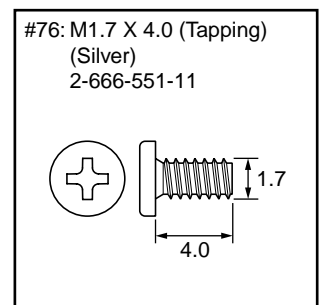
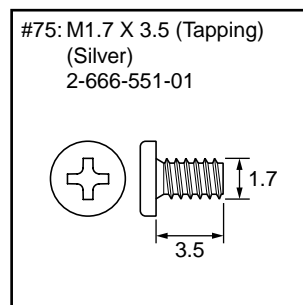
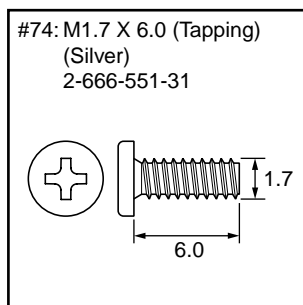
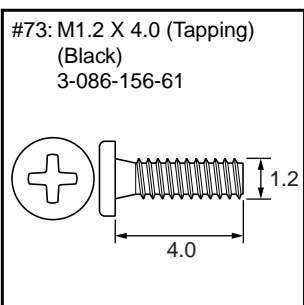
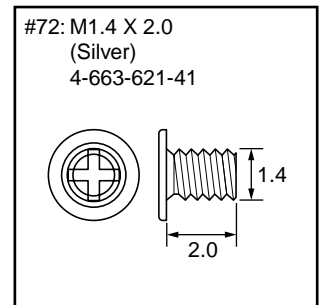
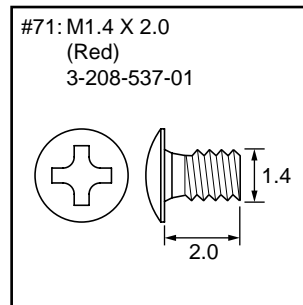
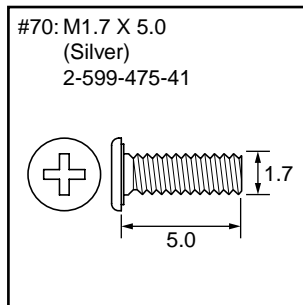
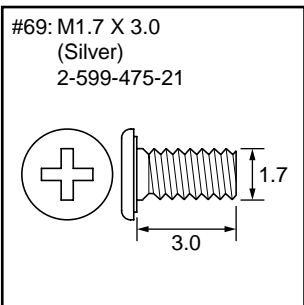
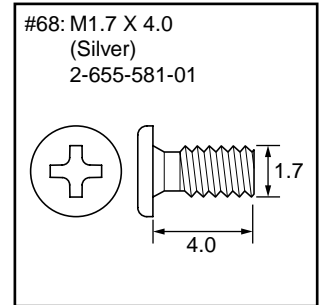
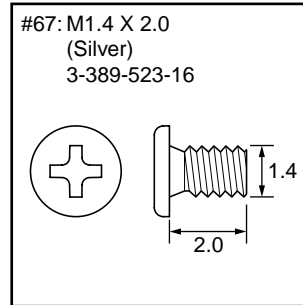
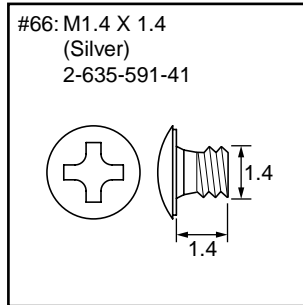
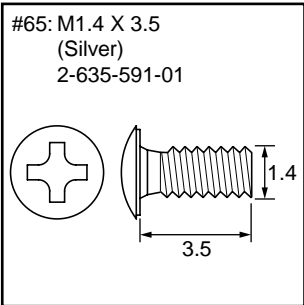
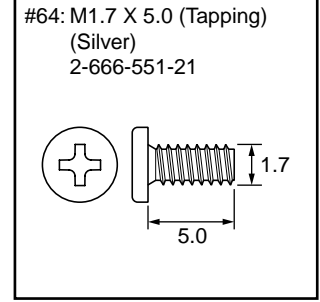
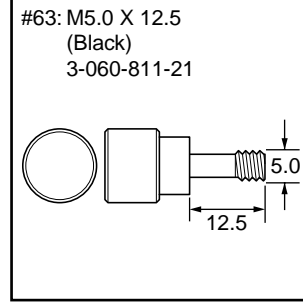
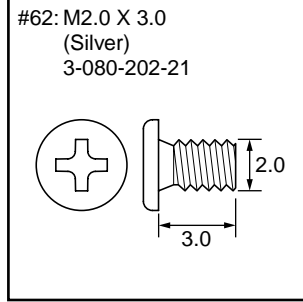
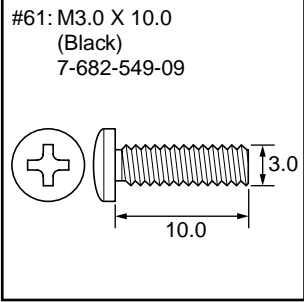

## HARDWARE LIST (5/8)

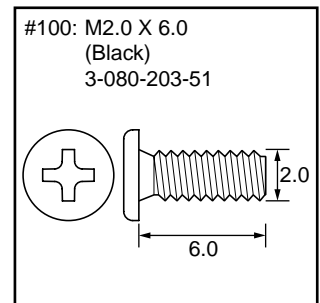
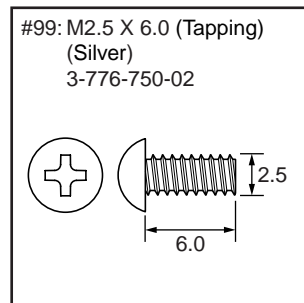
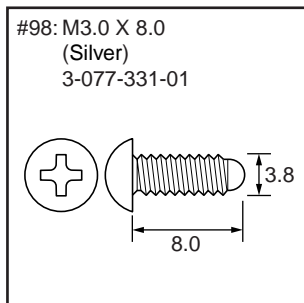
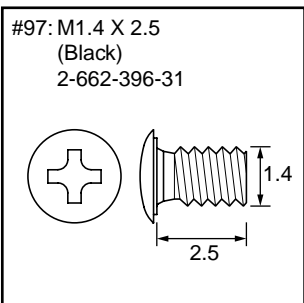
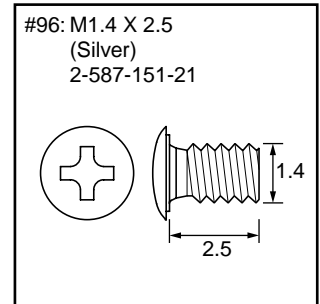
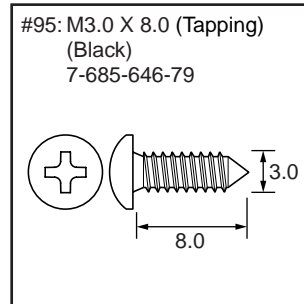
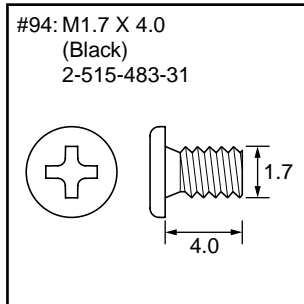
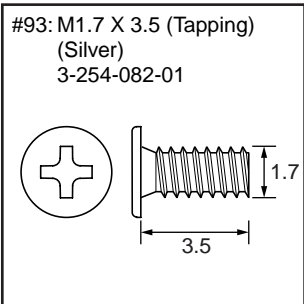
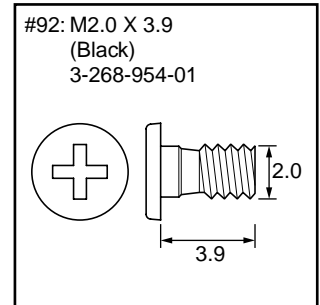
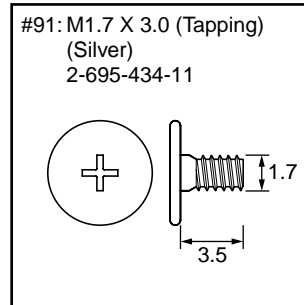
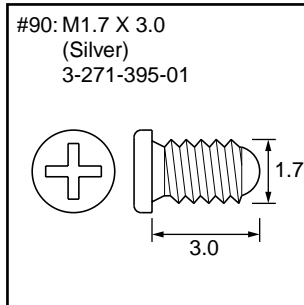
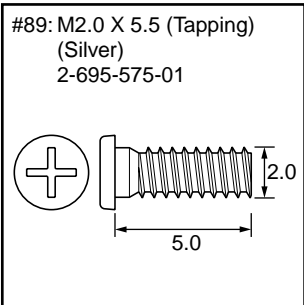
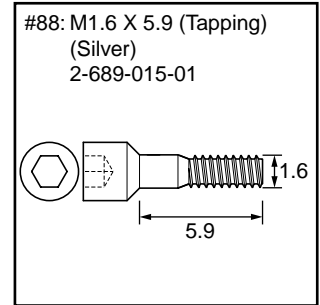
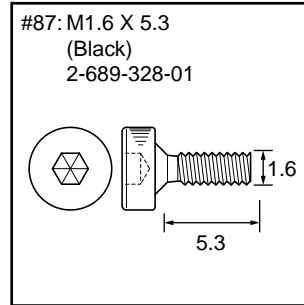
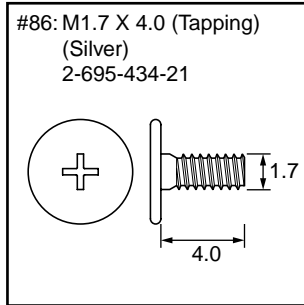
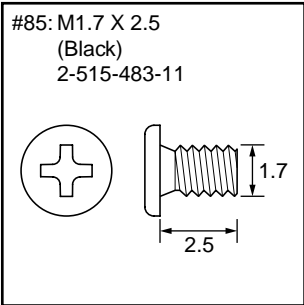
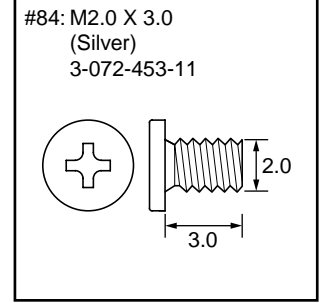
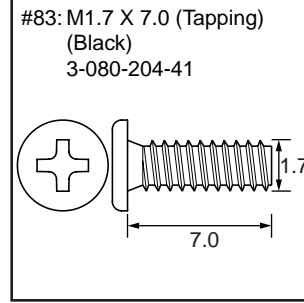
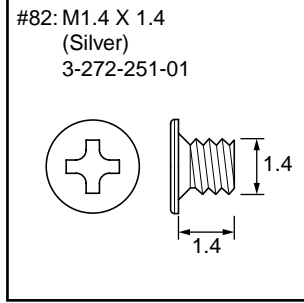
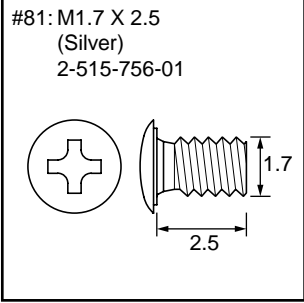

## HARDWARE LIST (6/8)

#101: M2.0 X 5.0  
(Silver)  
7-621-555-39

#102: M2.6 X 8.0  
(Black)  
7-621-284-30

#103: M2.6 X 10.0  
(Silver)  
7-685-794-09

#104: M3.0 X 8.0  
(Black)  
7-682-548-09

#105: M2.0 X 4.0  
(Red)  
2-891-494-31

#106: M2.0 X 6.0  
(Black)  
3-713-786-11

#107: M2.0 X 5.0  
(Silver)  
3-032-750-01

#108: M1.7 X 3.0 (Tapping)  
(Black)  
2-695-430-01

#109: M1.7 X 3.0  
(Black)  
2-515-483-21

#110: M2.0 X 3.0  
(Black)  
2-630-005-21

#111: M1.7 X 4.0 (Tapping)  
(Black)  
2-887-124-01

#112: M1.4 X 5.0  
(Black)  
2-178-410-11

#113: M1.7 X 5.0  
(Black)  
2-635-562-41

#114: M2.0 X 5.5 (Tapping)  
(Silver)  
2-698-464-01

#115: M1.4 X 3.5 (Tapping)  
(Silver)  
3-348-998-51

#116: M2.0 X 3.5 (Tapping)  
(Silver)  
2-695-435-01

#117: M1.7 X 4.5 (Tapping)  
(Silver)  
2-695-429-31

#118: M1.4 X 2.0  
(Black)  
2-655-580-01

#119: M2.6 X 5.0  
(Black)  
7-627-556-58

#120: M2.6 X 6.0  
(Silver)  
7-621-770-67

## HARDWARE LIST (7/8)

#121: M2.0 X 4.0 (Tapping)  
(Silver)  
3-080-205-11

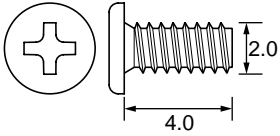

#122: M3.0 X 6.0  
(Black)  
7-682-547-09

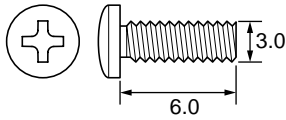

#123: M4.0 X 8.0  
(Black)  
7-682-561-09

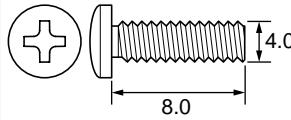

#124: M1.7 X 2.0  
(Silver)  
2-599-475-01

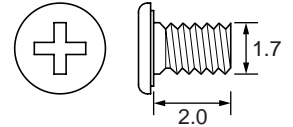

#125: M1.4 X 3.0  
(Black)  
3-291-847-01

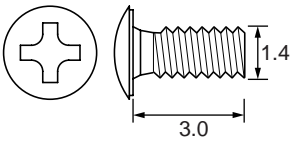

#126: M2.9 X 3.5  
(Black)  
3-292-616-01

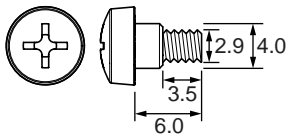

#127: M3.0 X 25.0  
(Black)  
7-682-654-09

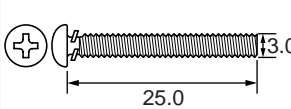

#128: M4.0 X 12.0  
(Black)  
3-452-472-01

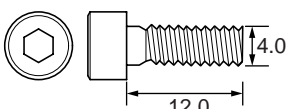

#129: M3.0 X 12.0  
(Black)  
7-682-550-09

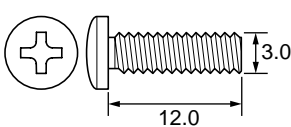

#130: M2.0 X 4.5 (Tapping)  
(Silver)  
3-732-817-11

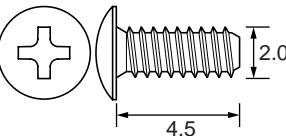

#131: M4.0 X 12.0  
(Silver)  
3-452-471-01

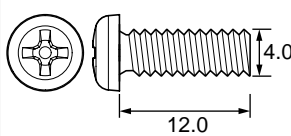

#132: M2.6 X 6.0  
(Black)  
4-673-655-01

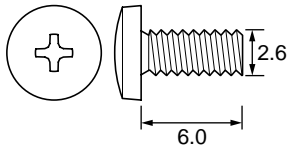

#133: M3.0 X 6.0  
(Black)  
3-452-484-01

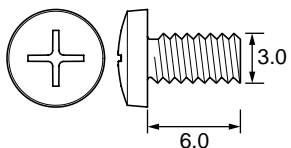

#134: M2.6 X 7.0  
(Black)  
3-299-572-01

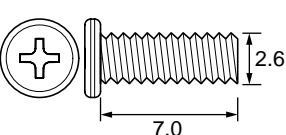

#135: M2.0 X 2.5  
(Black)  
7-627-553-28

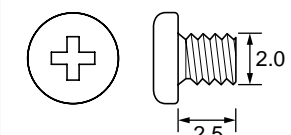

#136: M1.4 X 4.0 (Tapping)  
(Black)  
3-065-509-11

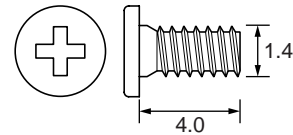

#137: M1.7 X 3.0  
(Black)  
3-090-976-62

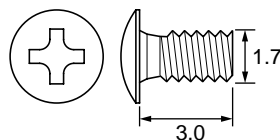

#138: M1.4 X 3.5  
(Silver)  
4-104-078-01

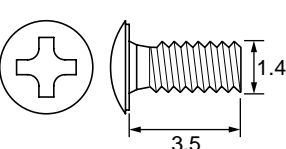

#139: M1.4 X 2.0  
(Silver)  
2-655-579-01

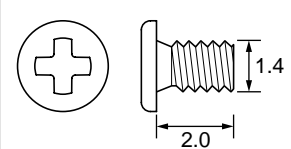

#140: M1.7 X 2.0  
(Black)  
2-635-562-01

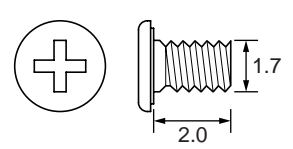

## HARDWARE LIST (8/8)

#141: M2.6 X 5.0 (Tapping)  
(Silver)  
7-685-791-01

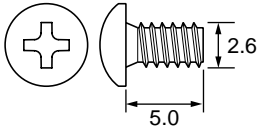

#142: M1.4 X 2.0  
(Silver)  
4-111-392-01

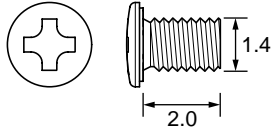

#143: M1.4 X 2.0  
(Black)  
4-111-392-11

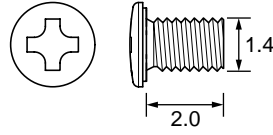

#144: M1.4 X 1.2  
(Silver)  
4-111-392-21

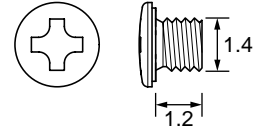

#145: M1.4 X 2.4  
(Silver)  
4-111-248-01

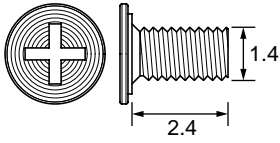

#146: M1.4 X 2.4  
(Black)  
4-111-248-11

