

DSC-T300

SERVICE MANUAL

LEVEL 2

Ver. 1.0 2008.02

Revision History

Internal memory
ON BOARD



Photo: Silver

US Model
Canadian Model
AEP Model
UK Model
E Model
Australian Model
Hong Kong Model
Chinese Model
Korea Model
Argentine Model
Japanese Model
Tourist Model

Link

SPECIFICATIONS	BLOCK DIAGRAMS	PRINTED WIRING BOARDS
SERVICE NOTE	FRAME SCHEMATIC DIAGRAM	REPAIR PARTS LIST
DISASSEMBLY	SCHEMATIC DIAGRAMS	

• Precaution on Replacing the SY-191 Board

The components identified by mark \triangle or dotted line with mark \triangle are critical for safety. Replace only with part number specified.

Les composants identifiés par une marque \triangle sont critiques pour la sécurité. Ne les remplacer que par une pièce portant le numéro spécifié.

Precaution on Replacing the Exterior Screw

DIGITAL STILL CAMERA

SONY®



SPECIFICATIONS

Camera

[System]

Image device: 7.7 mm (1/2.3 type) color CCD,
Primary color filter

Total pixel number of camera:
Approx. 10.3 Mega pixels

Effective pixel number of camera:
Approx. 10.1 Mega pixels

Lens:

Carl Zeiss Vario-Tessar 5× zoom lens
f = 5.8 – 29.0 mm (33 – 165 mm (35 mm
film equivalent))
F3.5 (W) – F4.4 (T)

Exposure control: Automatic exposure, Scene
Selection (11 modes)

White balance: Automatic, Daylight, Cloudy,
Fluorescent 1, 2, 3, Incandescent, Flash

Underwater White Balance: Auto, Underwater
1, 2, Flash

File format (DCF compliant):

Still images: Exif Ver. 2.21 JPEG compliant,
DPOF compatible
Movies: MPEG1 compliant (Monaural)

Recording media: Internal Memory
(approx. 15 MB), "Memory Stick Duo"

Flash: Flash range (ISO sensitivity
(Recommended exposure Index) set to Auto):
Approx. 0.1 to 3.5 m (4 inches to 11 feet
5 7/8 inches) (W)/approx. 0.8 to 2.7 m (2 feet
7 1/2 inches to 8 feet 10 3/8 inches) (T)

[Input and Output connectors]

Multi connector: Video output
Audio output (Monaural)
USB communication

USB communication: Hi-Speed USB (USB 2.0
compliant)

[LCD screen]

LCD panel:

Wide (16:9), 8.8 cm (3.5 type) TFT drive
Total number of dots: 230 400 (960 × 240) dots

[Power, general]

Power: Rechargeable battery pack NP-BD1, 3.6 V
NP-FD1 (not supplied), 3.6 V
AC-LSSK AC Adaptor (not supplied), 4.2 V

Power consumption (during shooting):
1.0 W

Operating temperature: 0 to 40°C (32 to 104° F)
Storage temperature: –20 to +60°C (–4 to +140° F)

Dimensions: 94.0 × 59.3 × 21.4 mm
(3 3/4 × 2 3/8 × 7/8 inches)
(W/H/D, excluding protrusions)

Mass (including NP-BD1 battery pack, paint pen
and strap etc.):
Approx. 177 g (6.2 oz)

Microphone: Monaural

Speaker: Monaural

Exif Print: Compatible

PRINT Image Matching III: Compatible

PictBridge: Compatible

BC-CSD battery charger

Power requirements: AC 100 V to 240 V,
50/60 Hz, 2.2 W

Output voltage: DC 4.2 V, 0.33 A

Operating temperature: 0 to 40°C (32 to 104° F)

Storage temperature: –20 to +60°C (–4 to
+140° F)

Dimensions: Approx. 62 × 24 × 91 mm (2 1/2 ×
3 1/32 × 3 5/8 inches) (W/H/D)

Mass: Approx. 75 g (2.7 oz)

Rechargeable battery pack NP-BD1

Used battery: Lithium-ion battery

Maximum voltage: DC 4.2 V

Nominal voltage: DC 3.6 V

Capacity: 2.4 Wh (680 mAh)

Design and specifications are subject to change
without notice.

CAUTION

Danger of explosion if battery is incorrectly replaced.
Replace only with the same or equivalent type.

SAFETY-RELATED COMPONENT WARNING!!

COMPONENTS IDENTIFIED BY MARK \triangle OR DOTTED LINE WITH MARK \triangle ON THE SCHEMATIC DIAGRAMS AND IN THE PARTS LIST ARE CRITICAL TO SAFE OPERATION. REPLACE THESE COMPONENTS WITH SONY PARTS WHOSE PART NUMBERS APPEAR AS SHOWN IN THIS MANUAL OR IN SUPPLEMENTS PUBLISHED BY SONY.

**ATTENTION AU COMPOSANT AYANT RAPPORT
À LA SÉCURITÉ!**

LES COMPOSANTS IDENTIFÉS PAR UNE MARQUE \triangle SUR LES DIAGRAMMES SCHÉMATIQUES ET LA LISTE DES PIÈCES SONT CRITIQUES POUR LA SÉCURITÉ DE FONCTIONNEMENT. NE REMPLACER CES COMPOSANTS QUE PAR DES PIÈSES SONY DONT LES NUMÉROS SONT DONNÉS DANS CE MANUEL OU DANS LES SUPPLÉMENTS PUBLIÉS PAR SONY.

SAFETY CHECK-OUT

After correcting the original service problem, perform the following safety checks before releasing the set to the customer.

1. Check the area of your repair for unsoldered or poorly-soldered connections. Check the entire board surface for solder splashes and bridges.
2. Check the interboard wiring to ensure that no wires are "pinched" or contact high-wattage resistors.
3. Look for unauthorized replacement parts, particularly transistors, that were installed during a previous repair. Point them out to the customer and recommend their replacement.
4. Look for parts which, through functioning, show obvious signs of deterioration. Point them out to the customer and recommend their replacement.
5. Check the B+ voltage to see it is at the values specified.
6. FLEXIBLE Circuit Board Repairing
 - Keep the temperature of the soldering iron around 270°C during repairing.
 - Do not touch the soldering iron on the same conductor of the circuit board (within 3 times).
 - Be careful not to apply force on the conductor when soldering or unsoldering.

Unleaded solder

Boards requiring use of unleaded solder are printed with the lead-free mark (LF) indicating the solder contains no lead.
(Caution: Some printed circuit boards may not come printed with the lead free mark due to their particular size.)



LF : LEAD FREE MARK

Unleaded solder has the following characteristics.

- Unleaded solder melts at a temperature about 40°C higher than ordinary solder.
Ordinary soldering irons can be used but the iron tip has to be applied to the solder joint for a slightly longer time.
Soldering irons using a temperature regulator should be set to about 350°C.
Caution: The printed pattern (copper foil) may peel away if the heated tip is applied for too long, so be careful!
- Strong viscosity
Unleaded solder is more viscous (sticky, less prone to flow) than ordinary solder so use caution not to let solder bridges occur such as on IC pins, etc.
- Usable with ordinary solder
It is best to use only unleaded solder but unleaded solder may also be added to ordinary solder.

1-1. PRECAUTION ON REPLACING THE SY-191 BOARD

DESTINATION DATA

When you replace to the repairing board, the written destination data of repairing board also might be changed to original setting. Refer to Service Manual ADJ, and perform "DESTINATION DATA WRITE".

USB SERIAL No.

The set is shipped with a unique ID (USB Serial No.) written in it.

This ID has not been written in a new board for service, and therefore it must be entered after the board replacement.

Refer to Service Manual ADJ, and perform "USB SERIAL No. INPUT".

1-2. SELF-DIAGNOSIS FUNCTION

1-2-1. Self-diagnosis Function

When problems occur while the unit is operating, the self-diagnosis function starts working, and displays on the LCD screen what to do.

Details of the self-diagnosis functions are provided in the Instruction manual.

1-2-2. Self-diagnosis Display

When problems occur while the unit is operating, the LCD screen shows a 4-digit display consisting of an alphabet and numbers, which blinks at 3.2 Hz. This 5-character display indicates the "repaired by:", "block" in which the problem occurred, and "detailed code" of the problem.

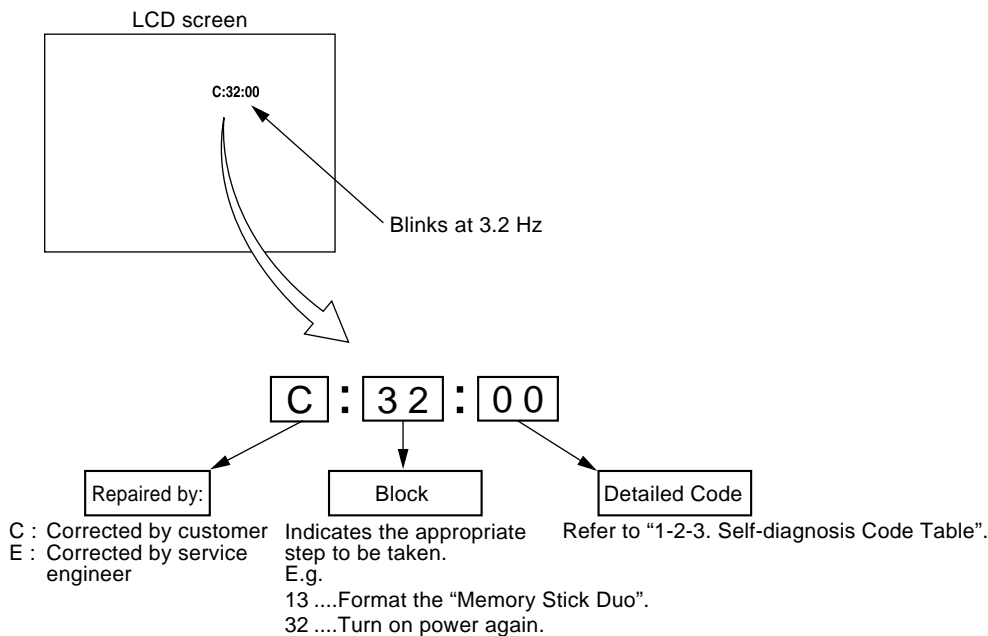

1-2-3. Self-diagnosis Code Table

Self-diagnosis Code				Symptom/State	Correction
Repaired by:	Block Function	Detailed Code			
C	1 3	0 1	The internal memory has experienced a format error.	Format the internal memory.	
			“Memory Stick Duo” is unformatted.	Format the “Memory Stick Duo”.	
			“Memory Stick Duo” is broken.	Insert a new “Memory Stick Duo”.	
			“Memory Stick Duo” type error	Insert a supported “Memory Stick Duo”.	
			The camera cannot read or write data on the “Memory Stick Duo”.	Turn the power off and on again, or taking out and inserting the “Memory Stick Duo” several times.	
C	3 2	0 1	Trouble with hardware	Turn the power off and on again.	
E	6 1	0 0	Difficult to adjust focus (Cannot initialize focus)	Retry turn the power on by the power switch. If it does not recover, check the focus reset sensor of lens block (pin ⑥ of CN402 on the SY-191 board). If it is OK, check the focus motor drive IC (IC401 on the SY-191 board).	
E	6 1	1 0	Zoom operations fault (Cannot initialize zoom lens.)	Retry turn the power on by the power switch. Check the zoom reset sensor of lens block (pin ⑨ of CN402 on the SY-191 board), if zooming is performed when the zoom button is operated. If it is OK, check the zoom motor drive IC (IC401 on the SY-191 board).	
E	6 2	0 2	Abnormality of IC for steadyspot.	Check or replacement of the IC for steadyspot (IC503 on the SY-191 board).	
E	6 2	1 0	Lens initializing failure.	Check or replacement of the IC for steadyspot (IC503 on the SY-191 board).	
E	6 2	1 1	Lens overheating (PITCH).	Check the HALL element (PITCH) of optical image stabilizer (pin ⑳, ㉑ of CN402 on the SY-191 board). If it is OK, check PITCH angular velocity sensor (SE502 on the SY-191 board) peripheral circuits.	
E	6 2	1 2	Lens overheating (YAW).	Check the HALL element (YAW) of optical image stabilizer (pin ㉓, ㉔ of CN402 on the SY-191 board). If it is OK, check YAW angular velocity sensor (SE501 on the SY-191 board) peripheral circuits.	
E	6 2	2 0	Abnormality of thermistor.	Check the OIS temp sensor of optical image stabilizer (pin ㉖ of CN402 on the SY-191 board).	
E	9 1	0 1	Abnormality when flash is being charged.	Checking of flash unit or replacement of flash unit. (Note)	
E	9 2	0 0	Non-standard battery is used.	Use the compatible battery only.	

Note: After repair, be sure to perform “1-3. PROCESS AFTER FIXING FLASH ERROR”.

1-3. PROCESS AFTER FIXING FLASH ERROR

When “FLASH error” (Self-diagnosis Code E : 91 : 01) occurs, to prevent any abnormal situation caused by high voltage, setting of the flash is changed automatically to disabling charge and flash setting.

After fixing, this setting needs to be deactivated. Flash error code can be initialized by the operations on the HOME screen.

Method for Initializing the Flash Error Code

Initialize

Initializes the setting to the default setting. Even if you execute this function, the images stored in the internal memory are retained.

- ① Touch [Initialize].
The message “Reset to default settings” appears.
- ② Touch [OK].
The settings are reset to the default setting.

To cancel initializing

Touch [Cancel] or [BACK] in step ②.

- Be sure not to power off the camera while initializing.

1-4. METHOD FOR COPYING OR ERASING THE DATA IN INTERNAL MEMORY

The data can be copied/erased by the operations on the HOME screen. (When erasing the data, execute formatting the internal memory.)

Note 1: When replacing the SY-191 board, erase the data in internal memory of the board before replacement.

Note 2: When replacing the SY-191 board, execute formatting and initializing the internal memory after replacement.

Method for Copying the Data in Internal Memory

Copy

Copies all images in the internal memory to a “Memory Stick Duo”.

- ① Insert a “Memory Stick Duo” having sufficient free capacity.
- ② Touch [Copy].
The message “All data on internal memory will be copied” appears.
- ③ Touch [OK].
Copying starts.

To cancel the copying

Touch [Cancel] or [BACK] in step ③.

- Use a fully charged battery pack. If you attempt to copy image files using a battery pack with little remaining charge, the battery pack may run out, causing copying to fail or possibly corrupting the data.
- You cannot select images to copy.
- The original images in the internal memory are retained even after copying. To delete the contents of the internal memory, remove the “Memory Stick Duo” after copying, then format the internal memory ([Format] in [Internal Memory Tool]).
- A new folder is created on the “Memory Stick Duo” and all the data will be copied to it. You cannot choose a specific folder and copy images to it.
- The DPOF (Print order) marks on the images are not copied.

Method for Formatting the Internal Memory

This item does not appear when a “Memory Stick Duo” is inserted in the camera.

Format

Formats the internal memory.

- Note that formatting permanently erases all data in the internal memory, including even protected images.
- ① Touch [Format].
The message “All data on internal memory will be erased” appears.
 - ② Touch [OK].
Formatting starts.

To cancel the formatting

Touch [Cancel] or [BACK] in step ②.

1-5. HOW TO WRITE DATA TO INTERNAL MEMORY

Usually, the camera has been set so as to disable the data writing from the PC to the internal memory of the camera. This setting must be changed temporarily when the data is to be written to the internal memory such as a case after the board replacement. To change the setting, use the write enable tool "WriteEnableTool.exe".

Data writing method

- 1) Connect the PC to the camera (USB mode: Mass Storage), and switch the driver to the "Sony Seus USB Driver".
- 2) Start the Write Enable Tool and the SeusEX.
- 3) Click the [Activate Write Enable Mode] button of the Write Enable Tool.

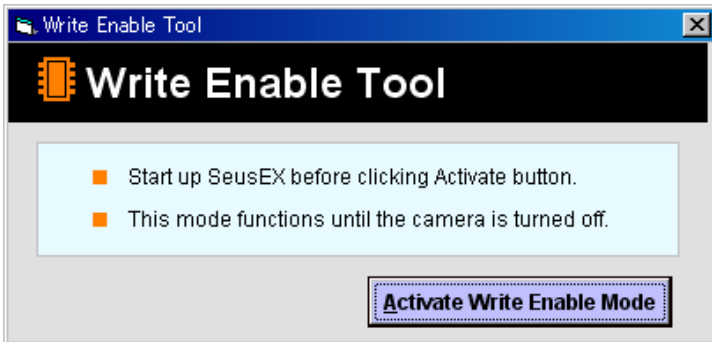

- 4) Upon completion of the setting change, the following message will be displayed.

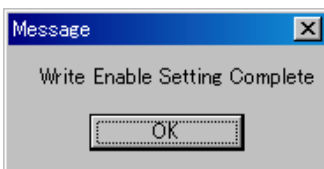

- 5) Return the driver to the original one, and connect the PC to the camera (USB mode: Mass Storage).
- 6) Write the data read out into the PC to the internal memory of the camera.
- 7) Disconnect the PC from the camera, and turn off the camera.

Note: By turning off the camera, the write enable setting is reset.

1-6. HOW TO DISTINGUISH CCD BLOCK

- 1) There are two types of modules used in the CCD BLOCK ASSY.
 - 2) They are interchangeability and only Type A is available for repair part.
 - 3) The sets used them are different in the parts structure.
- In case of repairing CCD BLOCK ASSY, be sure to check it as shown below.

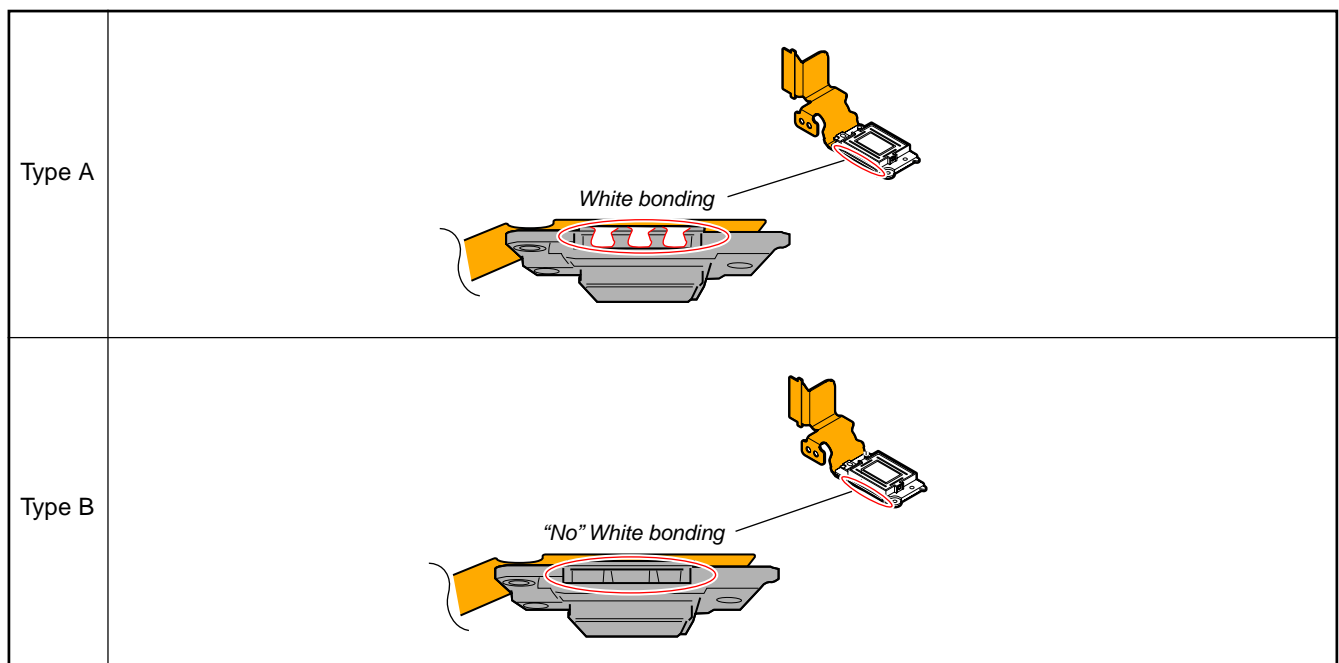

1-1. SY-191基板交換時の注意

仕向けデータ

補修用基板と交換する時、補修用基板に書かれている仕向けデータは元の設定と違う場合があります。ADJ編を参照して、「DESTINATION DATA WRITE」を行ってください。

USBシリアルNo.

セットは、1台毎に異なる固有のID (USB Serial No.) を書き込んだ後、出荷されています。新品の補修用基板には、このIDが書き込まれていないので、基板交換後にIDを入力する必要があります。ADJ編を参照して、「USB SERIAL No. INPUT」を行ってください。

1-2. 自己診断機能

1-2-1. 自己診断機能について

本機の動作に不具合が生じたとき、自己診断機能が働き、LCD画面に、どう処置したらよいか判断できる表示を行います。自己診断機能については取扱説明書にも掲載されています。

1-2-2. 自己診断表示

本機の動作に不具合が生じたとき、LCD画面にアルファベットと4桁の数字が表示され、3.2Hzで点滅します。この5文字の表示によって対応者分類および不具合の生じたブロックの分類、不具合の詳細コードを示します。

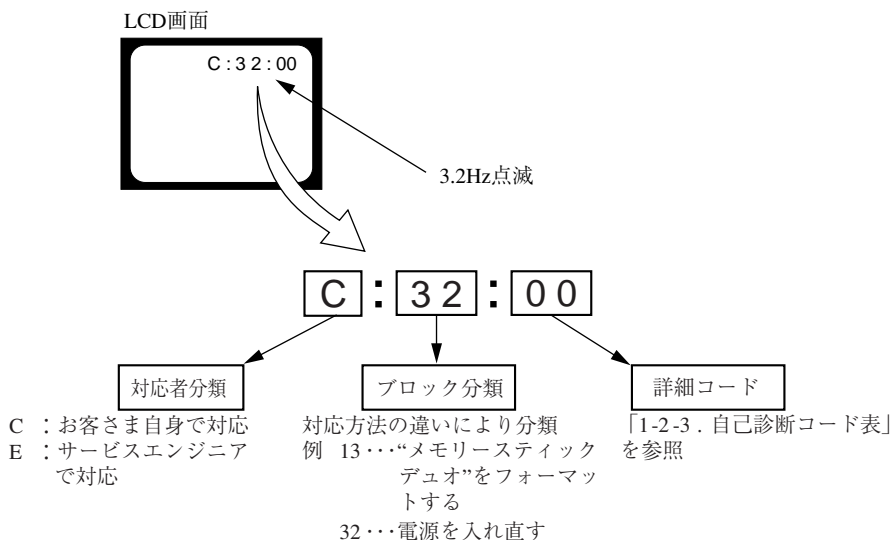

1-2-3. 自己診断コード表

自己診断コード			症状/状態	対応/方法
対応者	ブロック機能	詳細コード		
C	1 3	0 1	内蔵メモリにフォーマットエラーがあった。	内蔵メモリをフォーマットする。
			フォーマットしていない“メモリースティック デュオ”を入れた。	“メモリースティック デュオ”をフォーマットする。
			“メモリースティック デュオ”が壊れている。	新しい“メモリースティック デュオ”に交換する。
			“メモリースティック デュオ”のタイプエラーを検出した。	規格内の“メモリースティック デュオ”を挿入する。
			“メモリースティック デュオ”が読み/書きできない。	電源の入れ直し、または“メモリースティック デュオ”の挿し/外しを数回試す。
C	3 2	0 1	ハードウェアトラブルを検出した。	電源を入れ直す。
E	6 1	0 0	フォーカスが合にくい。 (フォーカスの初期化ができない)	操作スイッチの電源を入れ直す。 復帰しない場合はレンズブロックのフォーカスリセットセンサ (SY-191基板CN402 ⑥ピン) を点検する。異常なければフォーカスマータ駆動IC (SY-191基板IC401) を点検する。
E	6 1	1 0	ズーム動作の異常。 (ズームレンズの初期化ができない)	操作スイッチの電源を入れ直す。 ズームボタンを操作したときにズーム動作をすればレンズブロックのズームリセットセンサ (SY-191基板CN402 ⑨ピン) を点検する。異常なければズームモータ駆動IC (SY-191基板IC401) を点検する。
E	6 2	0 2	手振れ補正用ICの異常。	手振れ補正用IC (SY-191基板IC503) を点検または交換する。
E	6 2	1 0	手振れ補正用ICの異常。 (レンズ初期化異常)	手振れ補正用IC (SY-191基板IC503) を点検または交換する。
E	6 2	1 1	レンズオーバーヒート (PITCH)	光学手振れ補正ブロックのホール素子 (PITCH) (SY-191基板CN402 ⑩, ⑪ピン) を点検する。異常なければPITCH角速度センサ (SY-191基板SE502) 周辺の回路を点検する。
E	6 2	1 2	レンズオーバーヒート (YAW)	光学手振れ補正ブロックのホール素子 (YAW) (SY-191基板CN402 ⑬, ⑭ピン) を点検する。異常なければYAW角速度センサ (SY-191基板SE501) 周辺の回路を点検する。
E	6 2	2 0	サーミスタの異常。	光学手振れ補正ブロックのサーミスタ (SY-191基板CN402 ⑮ピン) を点検する。
E	9 1	0 1	フラッシュの充電異常。	フラッシュユニットを点検または交換する。(Note)
E	9 2	0 0	規定外の充電電池が使用された。	規定の充電電池を使用する。

Note : 交換後は、必ず「1-3. フラッシュエラー発生時の対処法」を行って下さい。

1-3. フラッシュエラー発生時の対処法

本機はフラッシュエラー（自己診断コードE：91：01）が発生した場合、高電圧による異常を防止するために自動的にフラッシュ充電および発光禁止の設定になります。

フラッシュエラー発生後はエラーの解除を行う必要があります。エラーの解除はホーム画面から初期化操作を実行することにより行います。

設定リセット

お買い上げ時の設定に戻します。
[設定リセット]を実行しても、内蔵メモリーに記録されている画像は削除されません。

- ① [設定リセット]をタッチする。
[全ての設定内容をリセットします]というメッセージが表示される。
- ② [実行]をタッチする。
設定リセットが実行される。

設定リセットを中止するには

手順②で、[キャンセル]または[BACK]をタッチする。

- 設定リセット中は電源が切れないようにご注意ください。

1-4. 内蔵メモリのデータコピーおよび消去方法

内蔵メモリのデータコピーまたは消去はホーム画面の操作から実行可能です。（消去する場合は内蔵メモリの初期化を行います。）

Note1：SY-191基板交換の際は、基板交換前に内蔵メモリのデータを消去して下さい。

Note2：SY-191基板交換の際は、基板交換後に内蔵メモリのフォーマットおよび初期化を実行して下さい。

内蔵メモリのコピー方法

コピー

内蔵メモリーに記録した画像を、“メモリースティック デュオ”に一括コピーします。

- ① 十分な空き容量のある“メモリースティックデュオ”を本体に入れる。
- ② [コピー]をタッチする。
「内蔵メモリーのデータがすべてコピーされます」というメッセージが表示される。
- ③ [実行]をタッチする。
コピーが実行される。

コピーを中止するには

手順③で、[キャンセル]または[BACK]をタッチする。

- 十分に充電したバッテリーをご使用ください。残量の少ないバッテリーを使用して画像ファイルをコピーすると、バッテリー切れのためデータを転送できなかったり、データを破損するおそれがあります。
- 画像ごとのコピーはできません。
- データをコピーしても、内蔵メモリー内のデータは削除されません。内蔵メモリーの内容を消去するには、コピー後に“メモリースティック デュオ”を本体から取りはずし、[内蔵メモリーツール]の[フォーマット]を行ってください。
- データのコピーをすると“メモリースティックデュオ”内に新しいフォルダが作成されます。コピー先のフォルダを指定することはできません。
- データのコピーを行っても、**DPOF**(プリント予約) マークの設定はコピーされません。

内蔵メモリのフォーマット方法

“メモリースティック デュオ”が本機に入っている場合のみ表示されます。

フォーマット

“メモリースティックデュオ”をフォーマット(初期化)します。市販の“メモリースティックデュオ”はフォーマット済みのため、フォーマットの必要はありません。

- フォーマットすると、プロテクトしてある画像も含めて、すべてのデータが消去され、元に戻せません。
- ① [フォーマット]をタッチする。
「メモリースティックのデータがすべて消去されます」というメッセージが表示される。
 - ② [実行]をタッチする。
フォーマットが実行される。

フォーマットを中止するには

手順②で、[キャンセル]または[BACK]をタッチする。

1-5. 内蔵メモリヘデータを書き戻す方法

通常は、PCからカメラの内蔵メモリヘデータを書き込むことはできない設定になっています。

基板交換後などに、内蔵メモリヘデータを書き戻す場合には、この設定を一時的に変更する必要があります。

設定の変更には、書き込み許可ツール (WriteEnableTool.exe) を使用します。

書き戻し方法

- 1) カメラとPCをマストレージ接続し、ドライバを"Sony Seus USB Driver"に切り替える。
- 2) 書き込み許可ツールとSeusEXを起動する。
- 3) 書き込み許可ツールの **Activate Write Enable Mode** ボタンをクリックする。

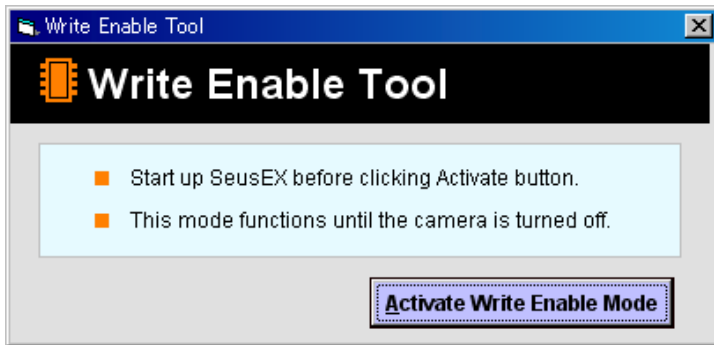

- 4) 設定の変更が終了すると、次のメッセージが表示されます。

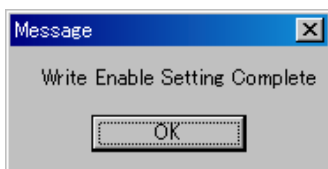

- 5) ドライバを元に戻して、カメラとPCをマストレージ接続する。
- 6) PCに読み出しておいたデータをカメラの内蔵メモリに書き込む。
- 7) カメラとPCの接続を解除し、カメラの電源をOFFにする。

注意：カメラの電源をOFFにすることにより、書き込み許可の設定が解除されます。

1-6. CCD BLOCK ASSYの見分け方

- 1) 本機に使用されている CCD BLOCK ASSY は2種類あります。
- 2) これらは互換性があり、補修用に使用されるのは下記 TYPE A になります。
- 3) これらを使用したセットは、部品構成が多少異なります。
CCD BLOCK ASSY を修理の際は、必ず下記をご確認ください。

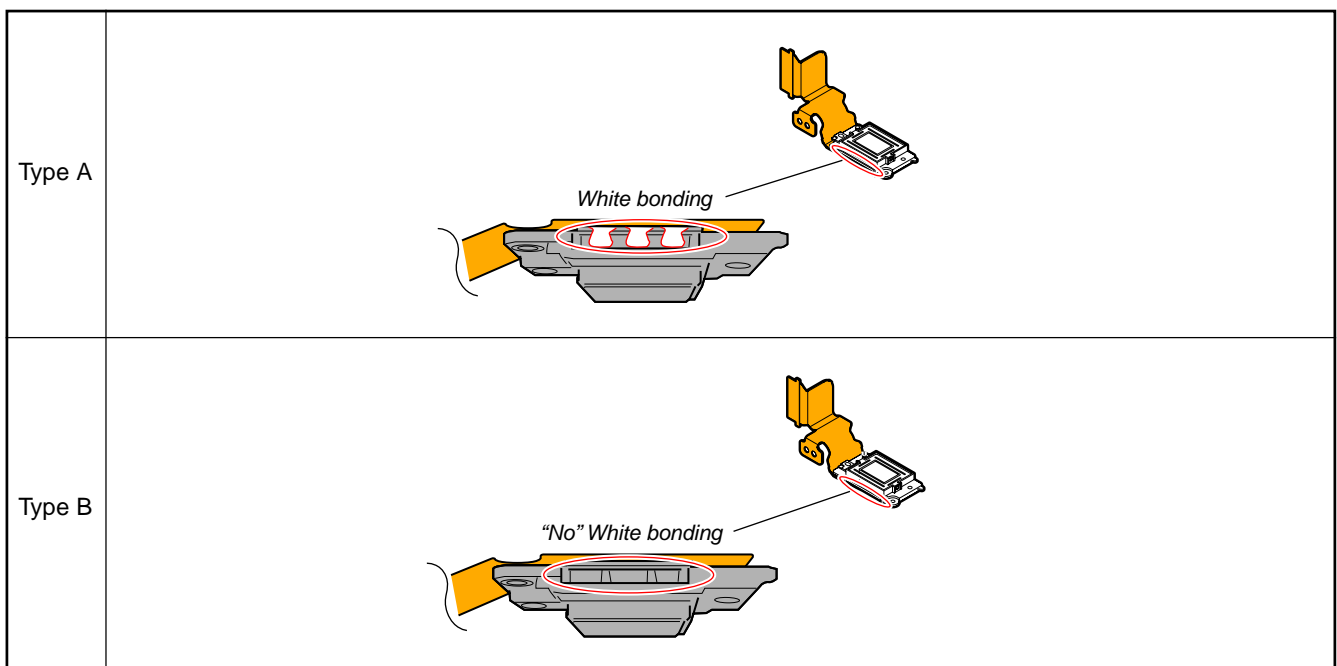

2. DISASSEMBLY

NOTE FOR REPAIR

- Make sure that the flat cable and flexible board are not cracked or bent at the terminal.
Do not insert the cable insufficiently nor crookedly.
- When remove a connector, don't pull at wire of connector. It is possible that a wire is snapped.
- When installing a connector, don't press down at wire of connector.
It is possible that a wire is snapped.
- Do not apply excessive load to the gilded flexible board.

Cut and remove the part of gilt which comes off at the point.
(Be careful or some pieces of gilt may be left inside)

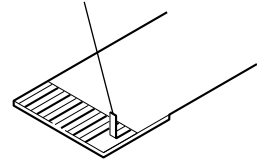

DISCHARGING OF THE ST-187 FLEXIBLE BOARD'S CHARGING CAPACITORS (C901, C902)

The charging capacitors (C901, C902) of the ST-187 board is charged up to the maximum 315 V potential.

There is a danger of electric shock by this high voltage when the capacitor is handled by hand. The electric shock is caused by the charged voltage which is kept without discharging when the main power of the unit is simply turned off. Therefore, the remaining voltage must be discharged as described below.

Preparing the Short Jig

To preparing the short jig, a small clip is attached to each end of a resistor of 1 k Ω / 1 W (1-215-869-11).

Wrap insulating tape fully around the leads of the resistor to prevent electrical shock.

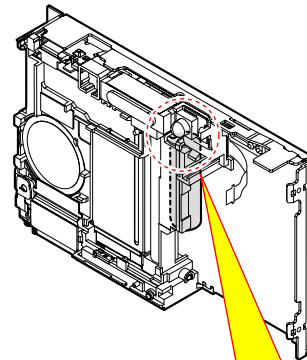
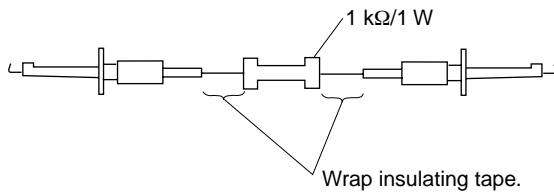

Note 2: High-voltage cautions

Discharging the Capacitor

Short-circuit between the two points with the short jig about 10 seconds.

To avoid the spark with the metal plate, wrap the short jig with the insulation tape.

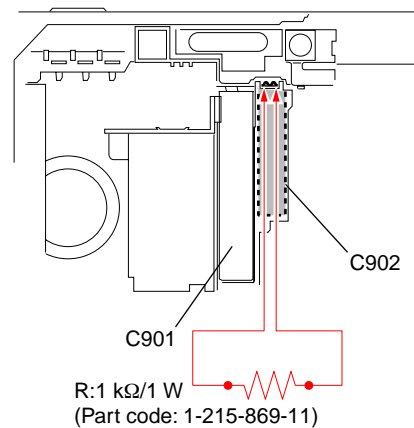

2-1. IDENTIFYING PARTS

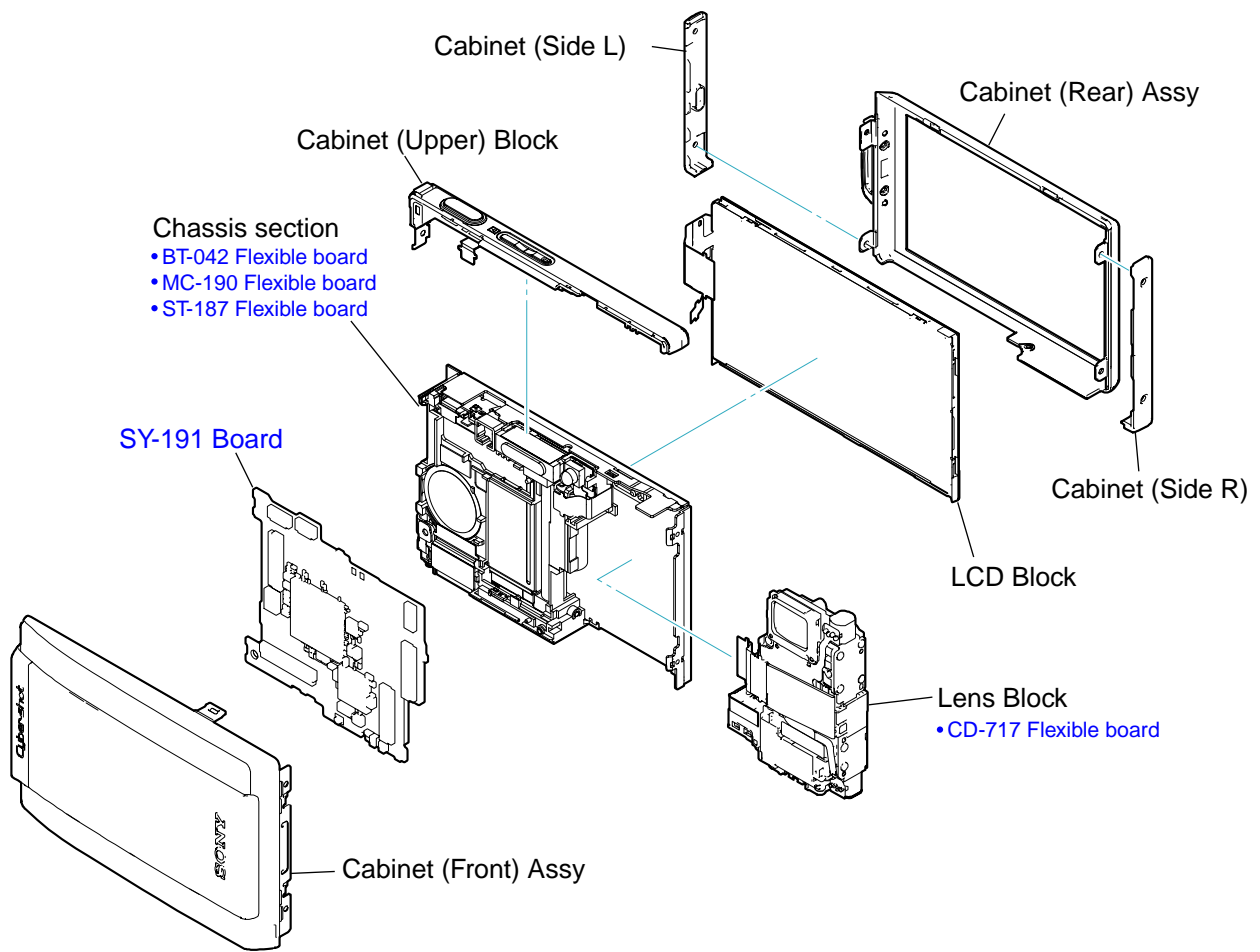

- DISASSEMBLY FLOW -

2-2-1. OVERALL SECTION

- Cabinet (Side R)
- Cabinet (Side L)
- Cabinet (Front) Assy
- Cabinet (Rear) Assy
- Cabinet (Upper) Block
- Lens Block
- LCD Block

2-2-2. CHASSIS SECTION

- SY-191 Board
- Main Flame
- ST-187 Flexible Board

2-2. DISASSEMBLY

EXPLODED VIEW

HARDWARE LIST

2-2-1. OVERALL SECTION

Follow the disassembly in the numerical order given.

- ① Cabinet (Front) Assy (①-1 to ①-6)
- ② Lens Block (②-1 to ②-6)
- ③ Cabinet (Rear) Assy (③-1)
- ④ LCD Block (④-1 to ④-3)
- ⑤ Cabinet (Upper) Block (⑤-1 to ⑤-3)

Note 1 :This screw cannot be re-used, Discard the the screw removed once in servicing. Instead, use a new screw.

When install the Cabinet (Upper) Block, be careful not to catch the flexible board.

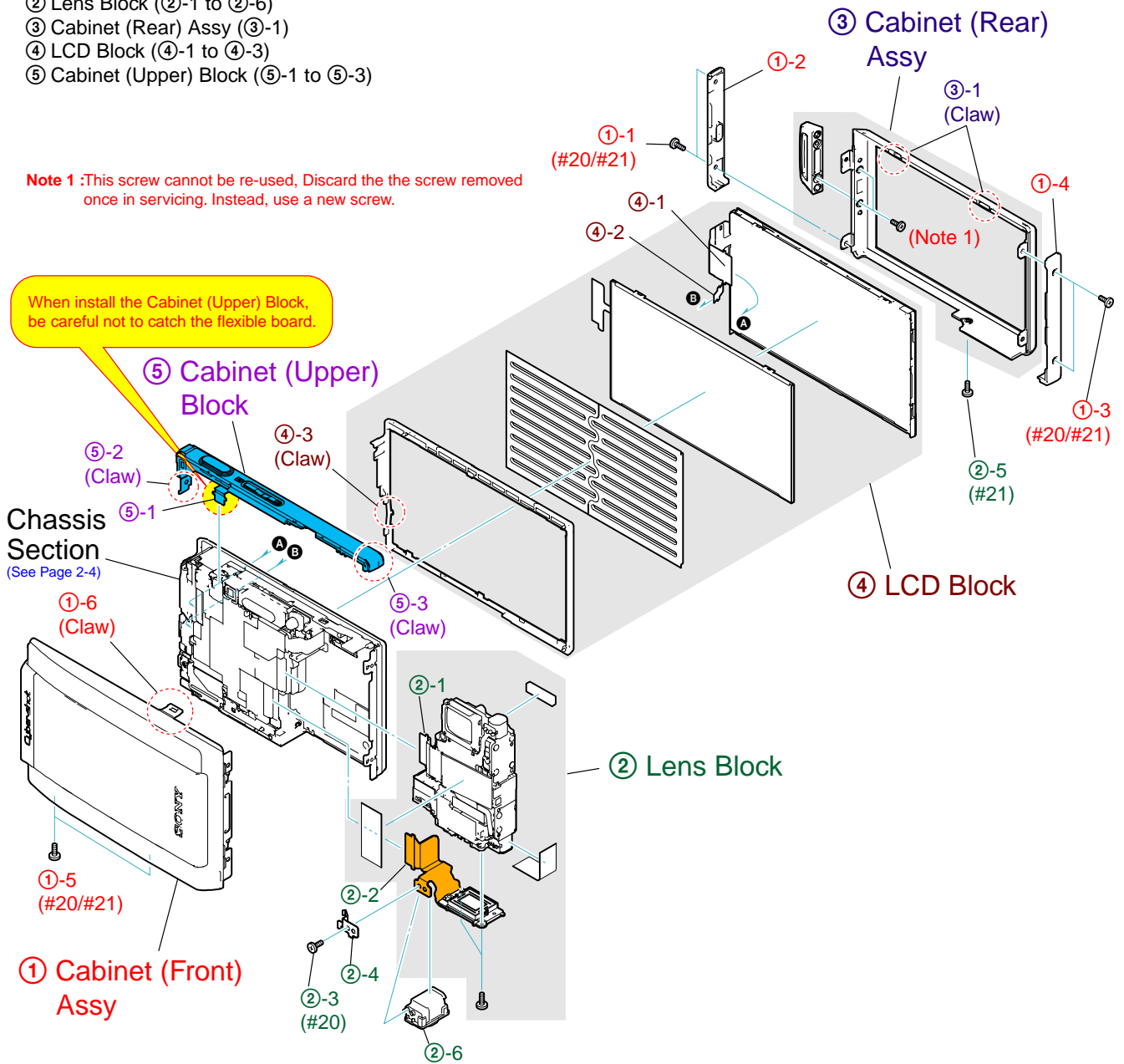

2-2-2. CHASSIS SECTION

Follow the disassembly in the numerical order given.

- ① SY-191 Board (①-1 to ①-8)
- ② Main Frame (②-1)
- ③ ST-187 Flexible Board (③-1 to ③-3)

EXPLODED VIEW

HARDWARE LIST

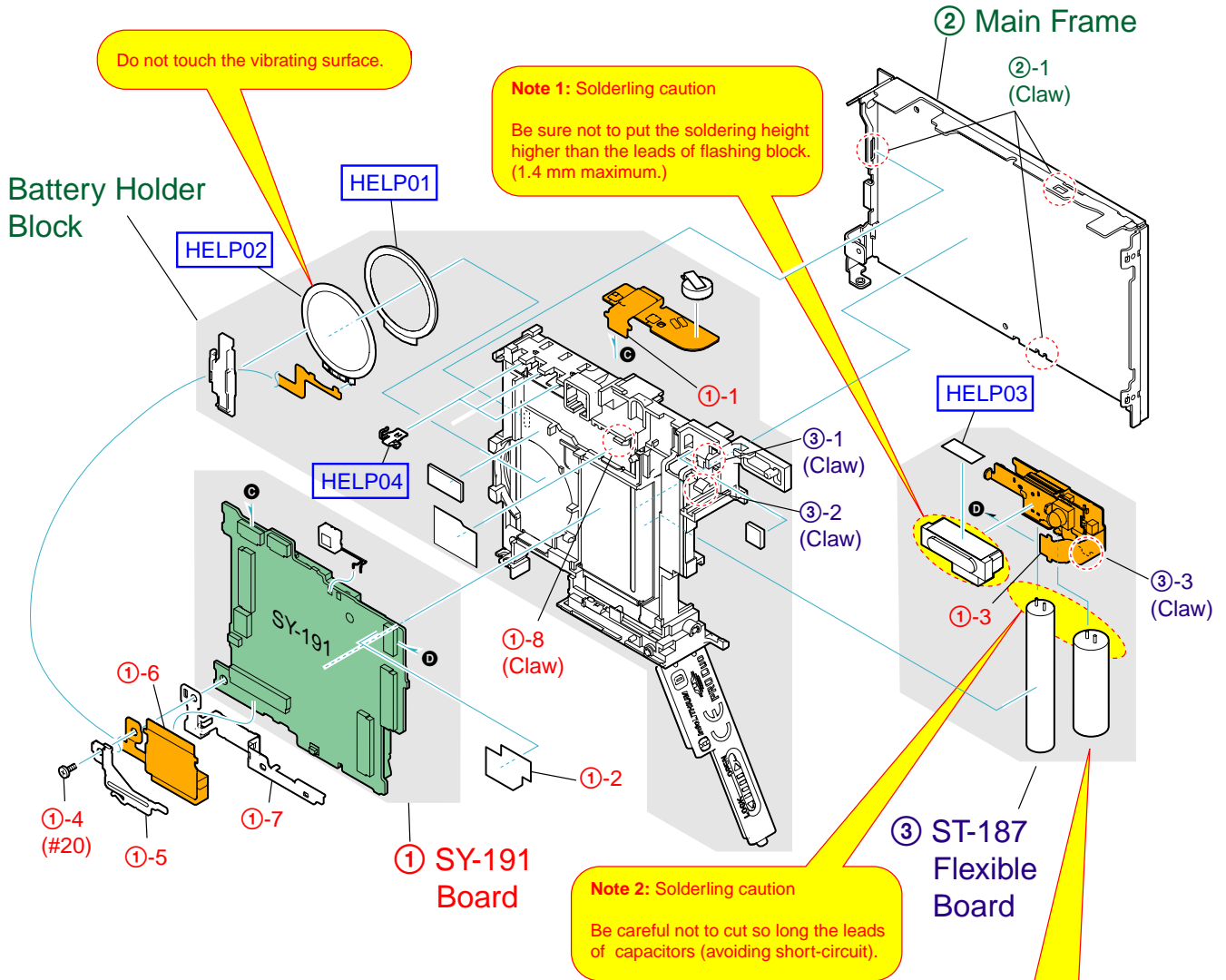

HELP

Sheet attachment positions and procedures of processing the flexible boards/harnesses are shown.

HELP01

NOTE ON PUTTING ADHESIVE SHEET (SP)

Be careful not to put adhesive sheet (SP) out of cavity for speaker.

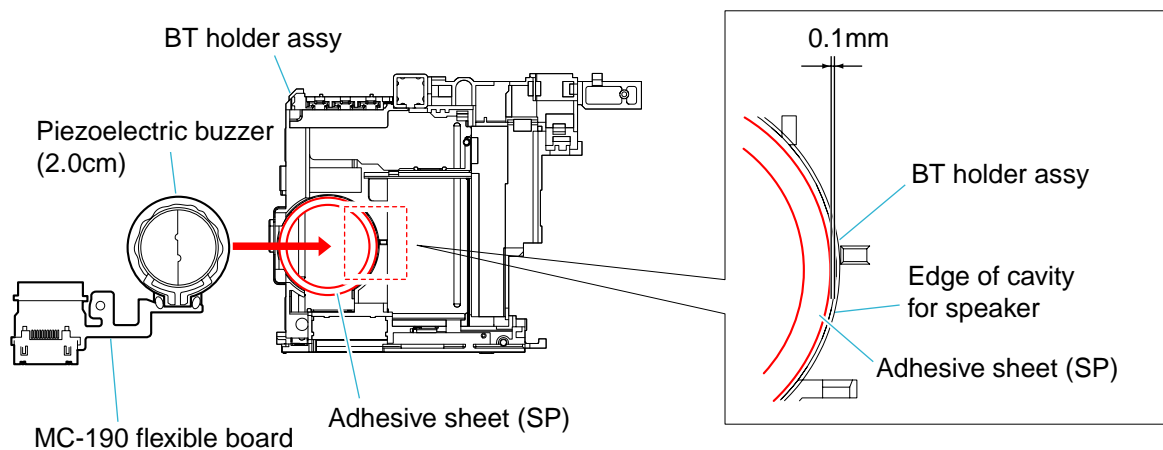

HELP02

Positioning sheet for soldering the piezoelectric buzzer (SP901)

When soldering, print this sheet and use this as a workbench for positioning.

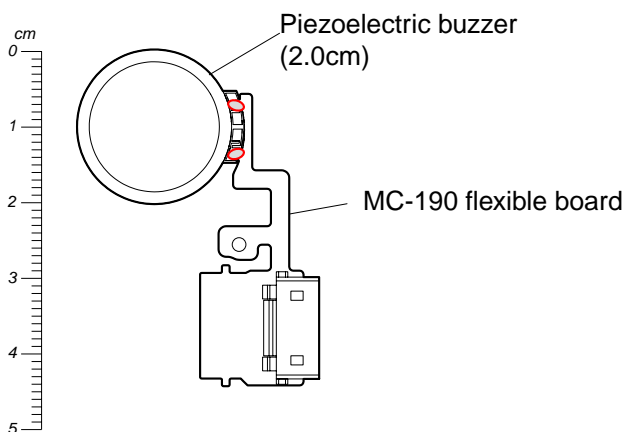

Note: Use this drawing in its actual scale.

If you cannot print this out in its actual scale, the PC or printer setting is a probable cause. In such a case, use a photocopier or another tool to obtain the actual size.

Note: Be sure not to put the soldering height higher than 0.7mm.

HELP03

INSULATING SHEET (ST) PUTTING POSITION

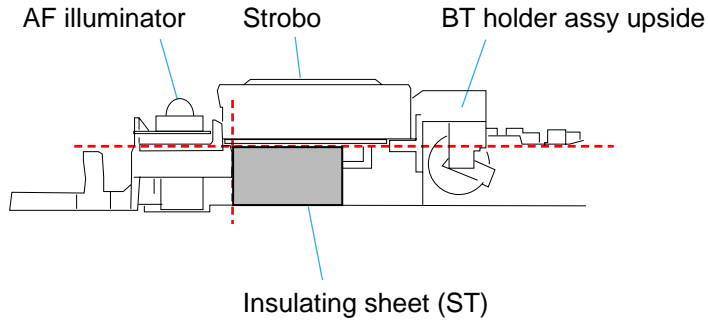

HELP04

INSTALLATION METHOD OF THE BATTERY TERMINAL BOARD (BH001)

- ① Inserts the battery terminal board (BH001) into a slit in the BT holder assy to install. The battery terminal board (BH001) are attached with the notch for installation.

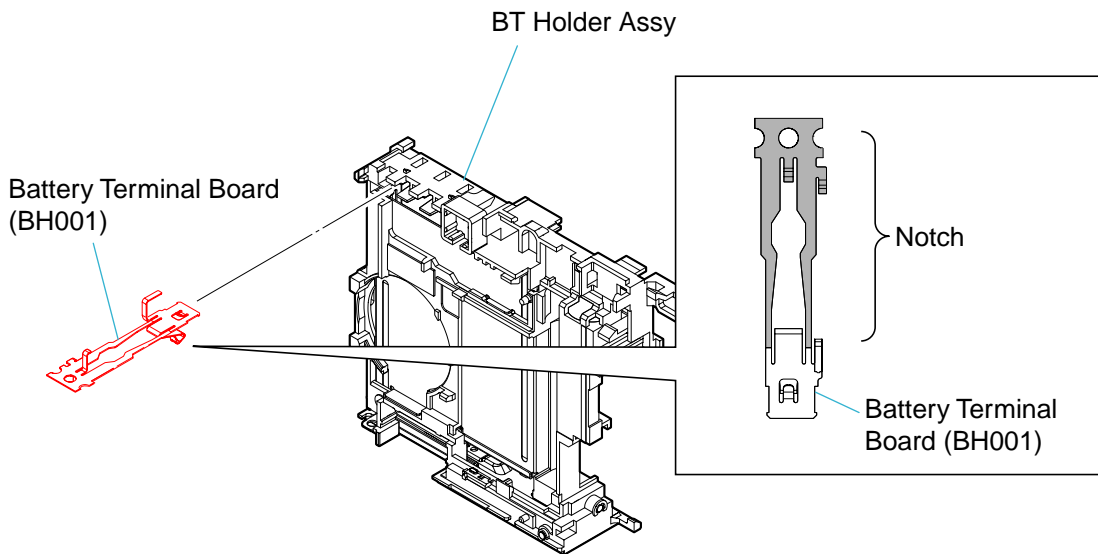

- ② Fold the notch 3 or 4 times repeatedly to break.

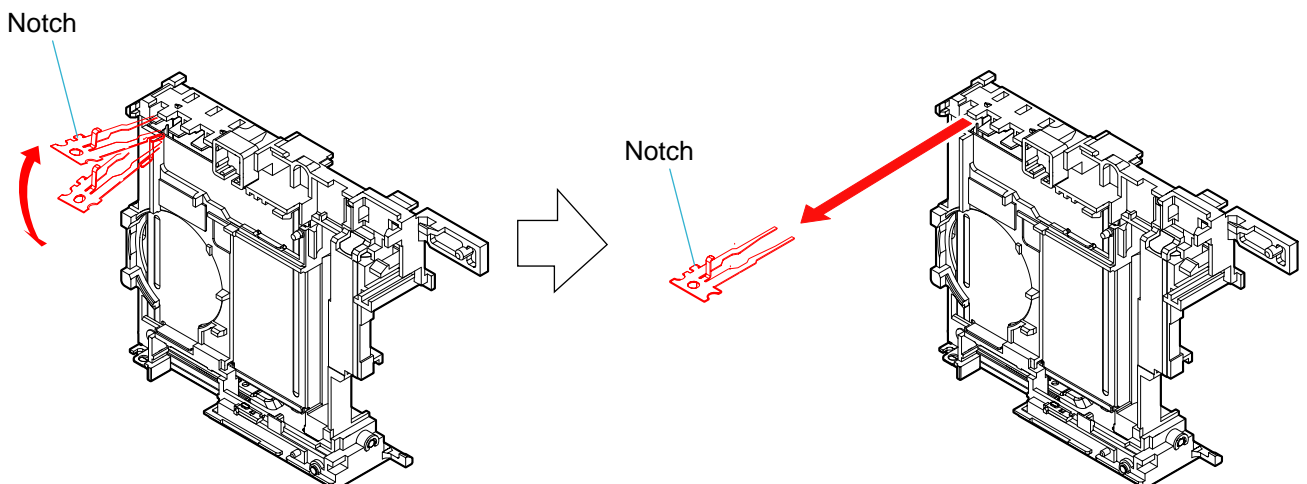

3. BLOCK DIAGRAMS

Link

• [OVERALL BLOCK DIAGRAM \(1/2\)](#)

• [POWER BLOCK DIAGRAM \(1/2\)](#)

• [OVERALL BLOCK DIAGRAM \(2/2\)](#)

• [POWER BLOCK DIAGRAM \(2/2\)](#)

3. BLOCK DIAGRAMS

3-1. OVERALL BLOCK DIAGRAM (1/2) () : Number in parenthesis () indicates the division number of schematic diagram where the component is located.

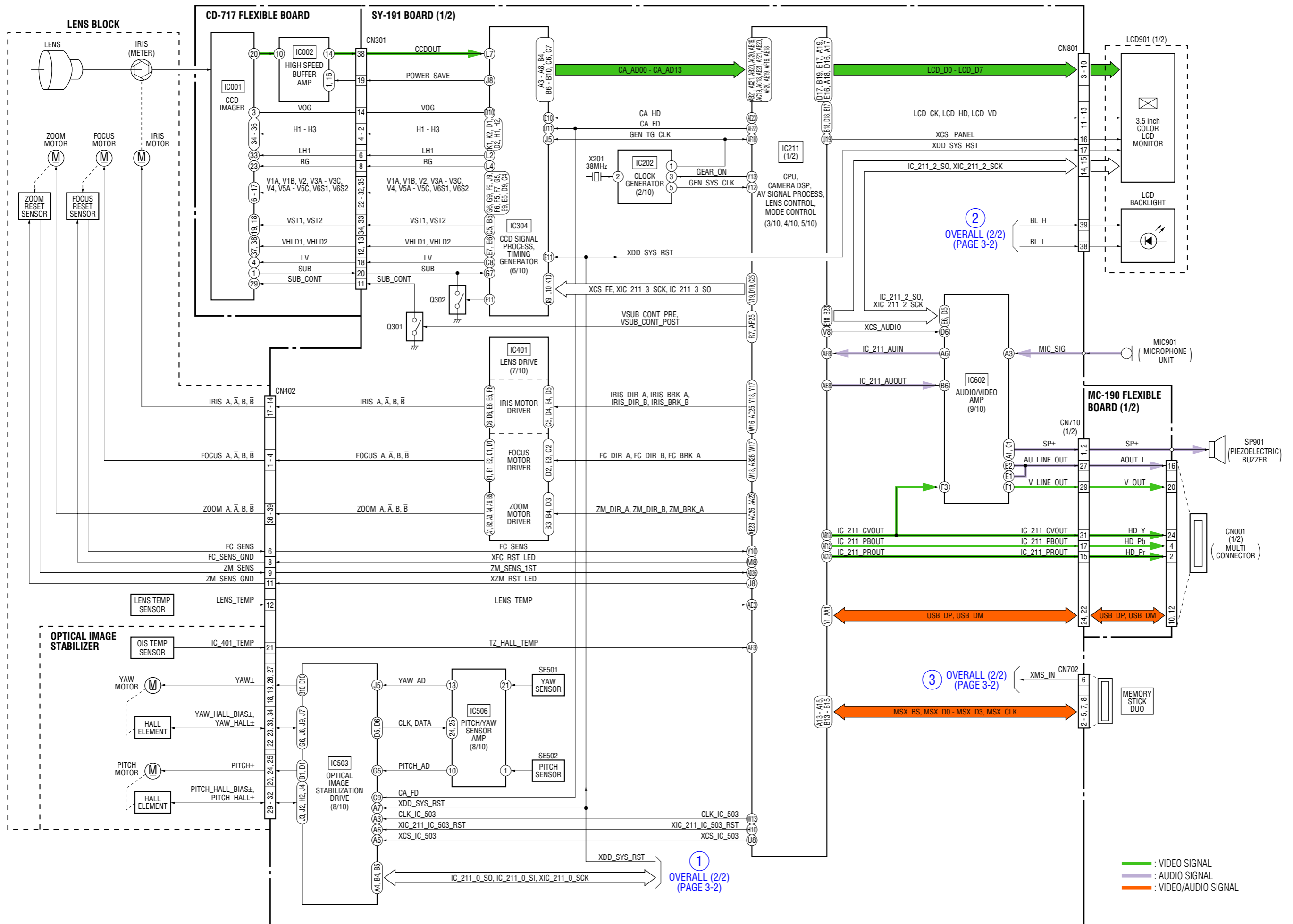

3-2. OVERALL BLOCK DIAGRAM (2/2) () : Number in parenthesis () indicates the division number of schematic diagram where the component is located.

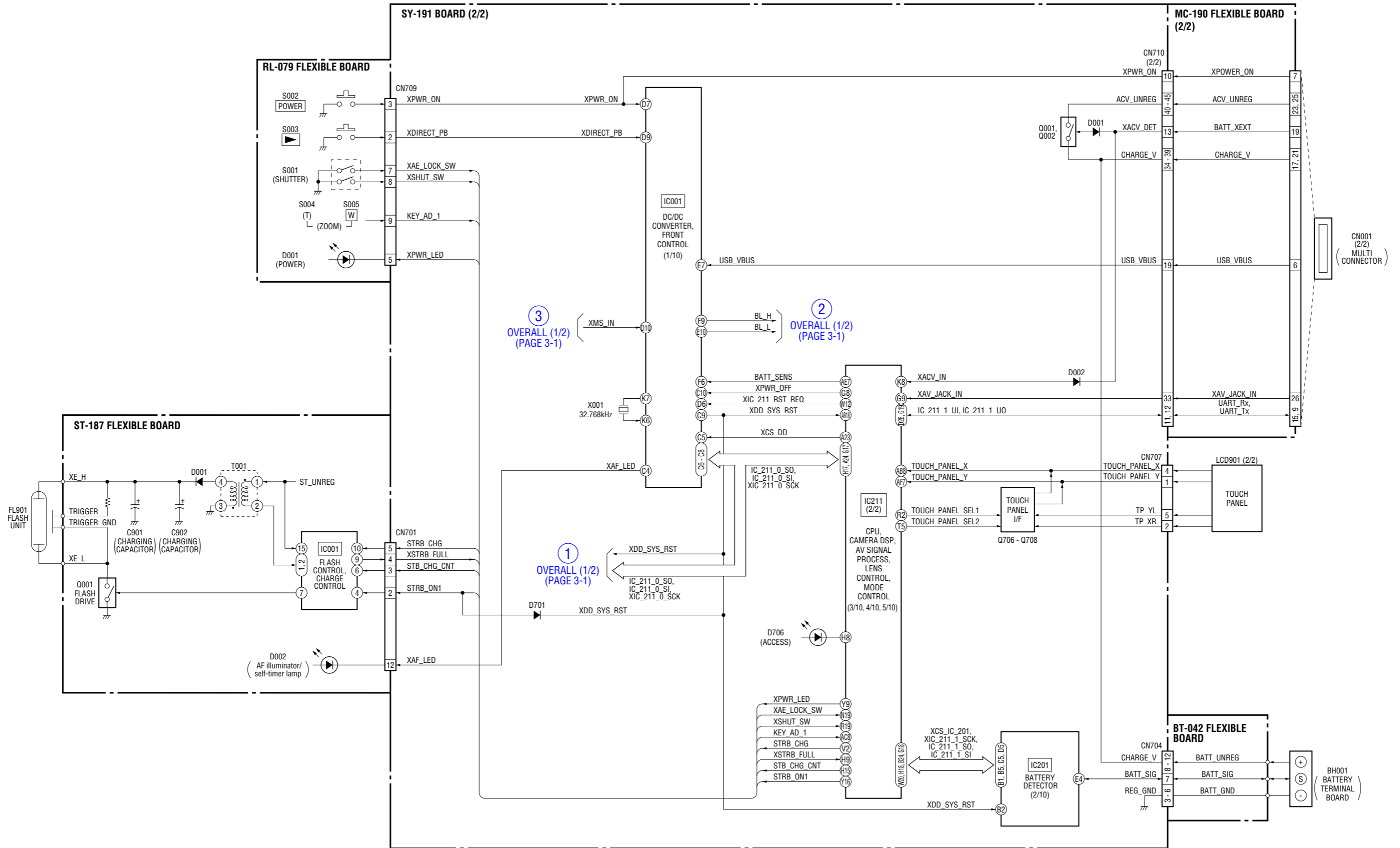

3-3. POWER BLOCK DIAGRAM (1/2)

() : Number in parenthesis () indicates the division number of schematic diagram where the component is located.

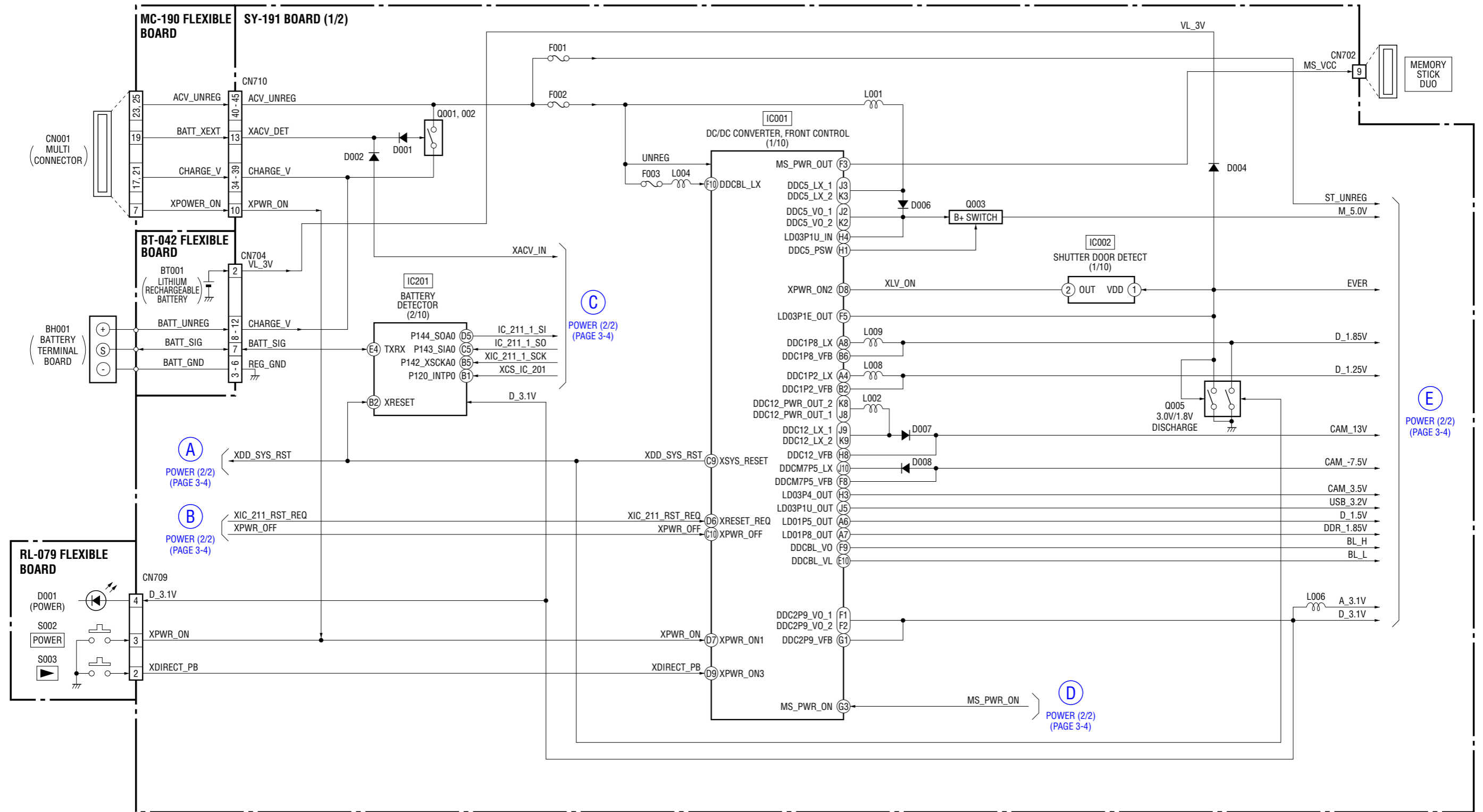

3-4. POWER BLOCK DIAGRAM (2/2)

() : Number in parenthesis () indicates the division number of schematic diagram where the component is located.

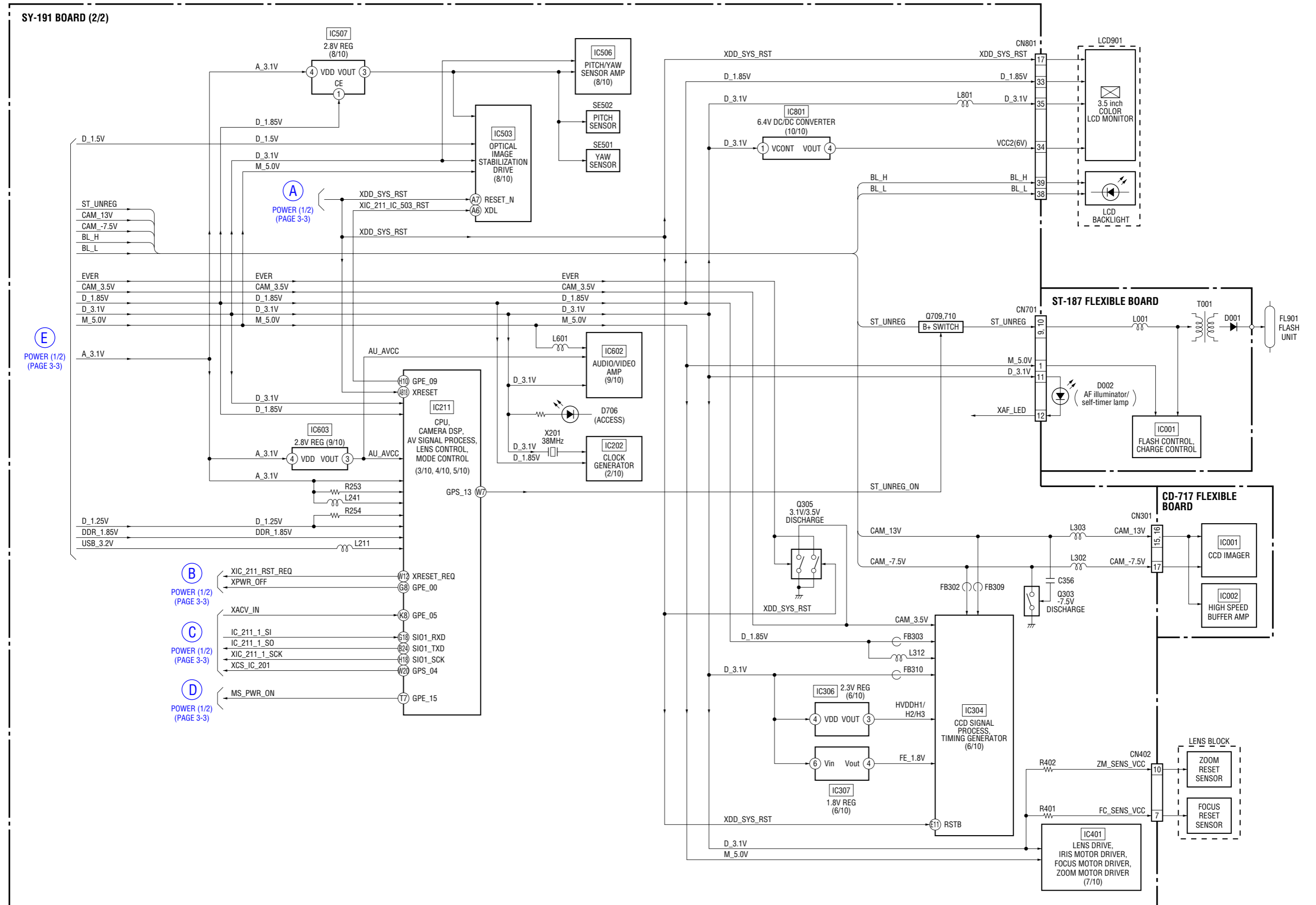

4. PRINTED WIRING BOARDS AND SCHEMATIC DIAGRAMS

4-1. FRAME SCHEMATIC DIAGRAM

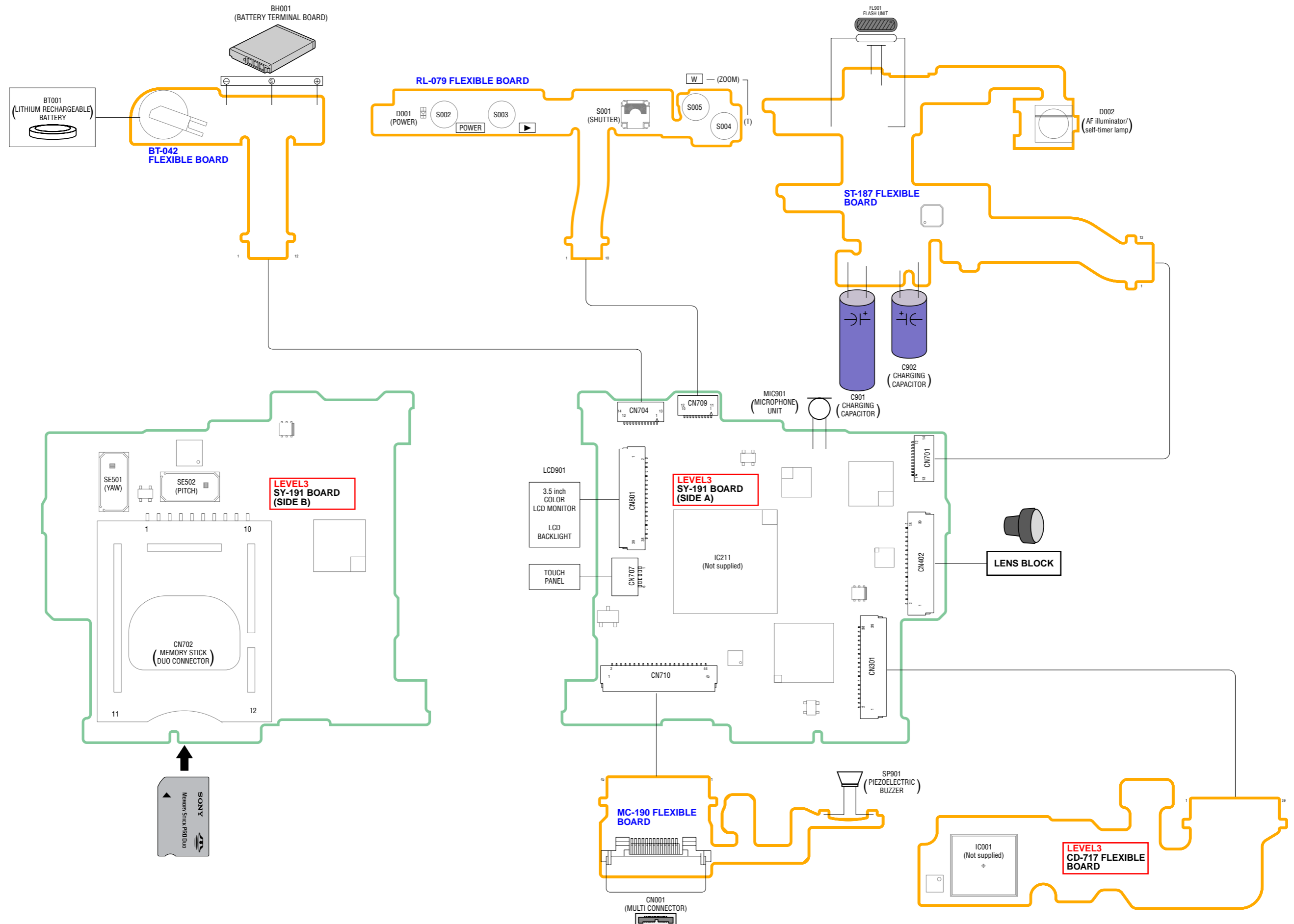

4-2. SCHEMATIC DIAGRAMS

Link

<ul style="list-style-type: none">• MC-190 FLEXIBLE BOARD (MULTI CONNECTOR)	<ul style="list-style-type: none">• ST-187 FLEXIBLE BOARD (FLASH DRIVE)
<ul style="list-style-type: none">• RL-079 FLEXIBLE BOARD (CONTROL SWITCH)	<ul style="list-style-type: none">• BT-042 FLEXIBLE BOARD (BATTERY IN)
<ul style="list-style-type: none">• COMMON NOTE FOR SCHEMATIC DIAGRAMS	

4-2. SCHEMATIC DIAGRAMS

4. PRINTED WIRING BOARDS AND SCHEMATIC DIAGRAMS

4-2. SCHEMATIC DIAGRAMS

THIS NOTE IS COMMON FOR SCHEMATIC DIAGRAMS
(In addition to this, the necessary note is printed in each block)

(For schematic diagrams)

- All capacitors are in μF unless otherwise noted. pF : μF . 50 V or less are not indicated except for electrolytics and tantalums.
- Chip resistors are 1/10 W unless otherwise noted. $\text{k}\Omega=1000 \Omega$, $\text{M}\Omega=1000 \text{k}\Omega$.
- Caution when replacing chip parts.
New parts must be attached after removal of chip.
Be careful not to heat the minus side of tantalum capacitor, Because it is damaged by the heat.
- Some chip part will be indicated as follows.

	C541	L452	
	22U	10UH	
	TA A	2520	
Kinds of capacitor			External dimensions (mm)
			Case size

- Constants of resistors, capacitors, ICs and etc with XX indicate that they are not used.
In such cases, the unused circuits may be indicated.
- Parts with ★ differ according to the model/destination. Refer to the mount table for each function.
- All variable and adjustable resistors have characteristic curve B, unless otherwise noted.
- Signal name
XEDIT → EDIT PB/XREC → PB/REC
- : non flammable resistor
- : fusible resistor
- : panel designation
- : B+ Line
- : B- Line
- : IN/OUT direction of (+,-) B LINE.
- : adjustment for repair.
- : not use circuit

(Measuring conditions voltage and waveform)

- Voltages and waveforms are measured between the measurement points and ground when camera shoots color bar chart of pattern box. They are reference values and reference waveforms.
(VOM of DC 10 M Ω input impedance is used)
- Voltage values change depending upon input impedance of VOM used.)

Precautions for Replacement of Imager

- If the imager has been replaced, carry out all the adjustments for the camera section.
- As the imager may be damaged by static electricity from its structure, handle it carefully like for the MOS IC.
In addition, ensure that the receiver is not covered with dusts nor exposed to strong light.

1. Connection

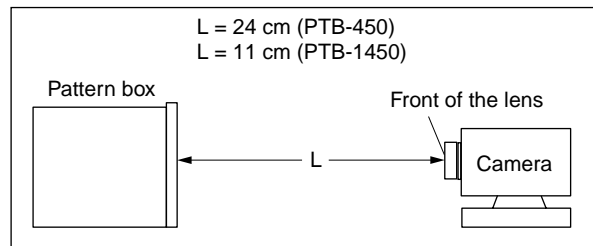
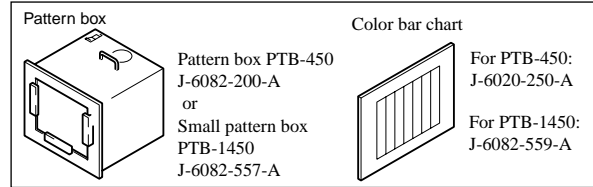

2. Adjust the distance so that the output waveform of Fig. a and the Fig. b can be obtain.

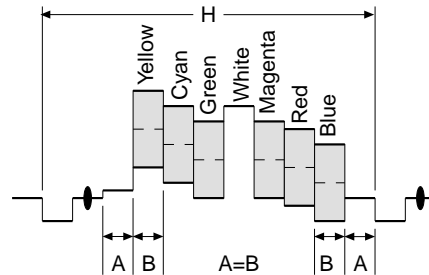

Fig. a (Video output terminal output waveform)

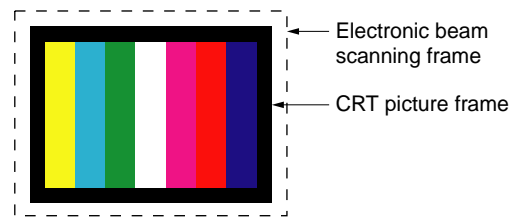

Fig.b (Picture on monitor TV)

When indicating parts by reference number, please include the board name.

The components identified by mark Δ or dotted line with mark Δ are critical for safety. Replace only with part number specified.

Les composants identifiés par une marque Δ sont critiques pour la sécurité. Ne les remplacer que par une pièce portant le numéro spécifié.

Schematic diagrams of the CD-717 flexible board and the SY-191 board are not shown.
Pages from 4-3 to 4-13 are not shown.

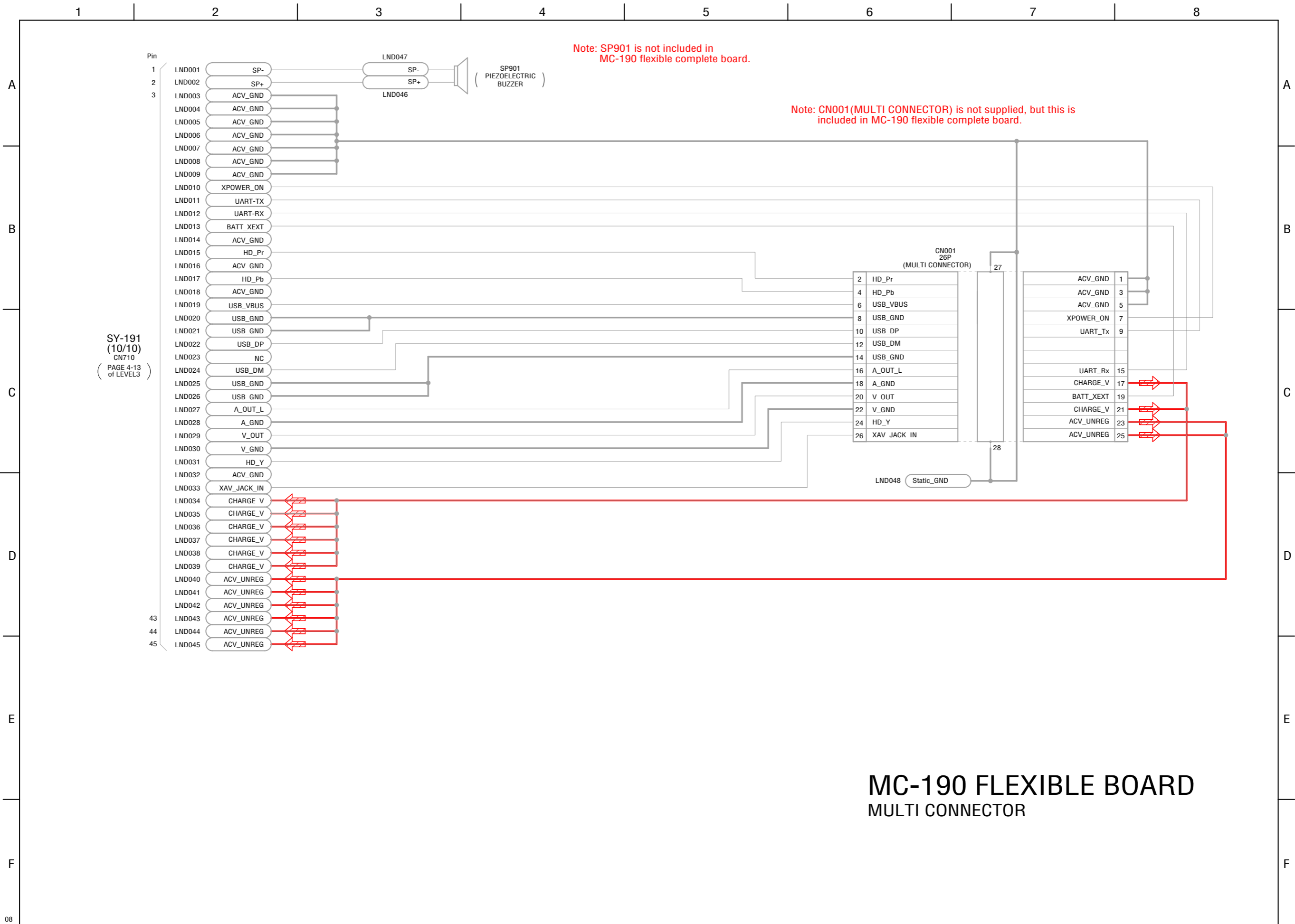

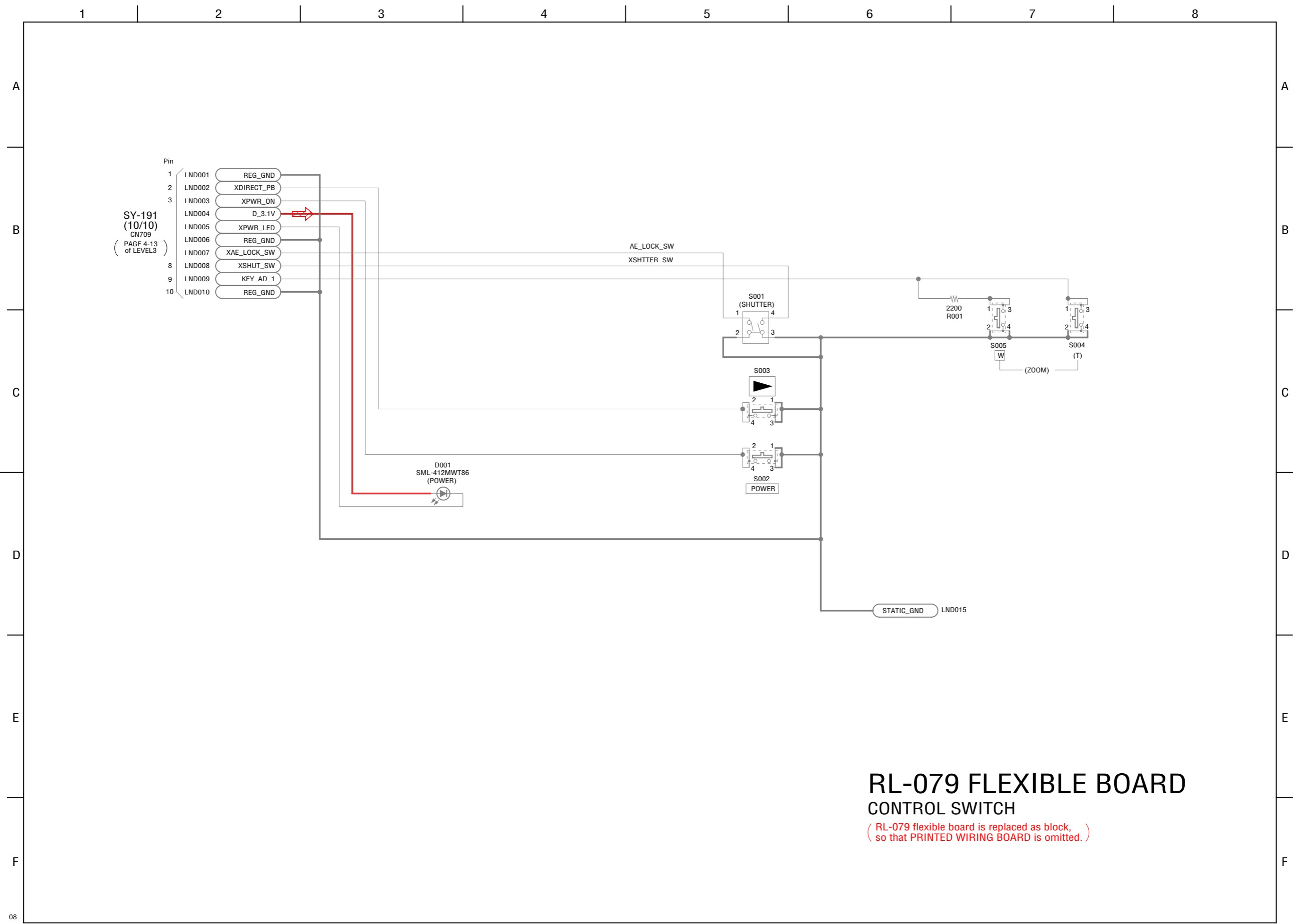

RL-079 FLEXIBLE BOARD CONTROL SWITCH

(RL-079 flexible board is replaced as block, so that PRINTED WIRING BOARD is omitted.)

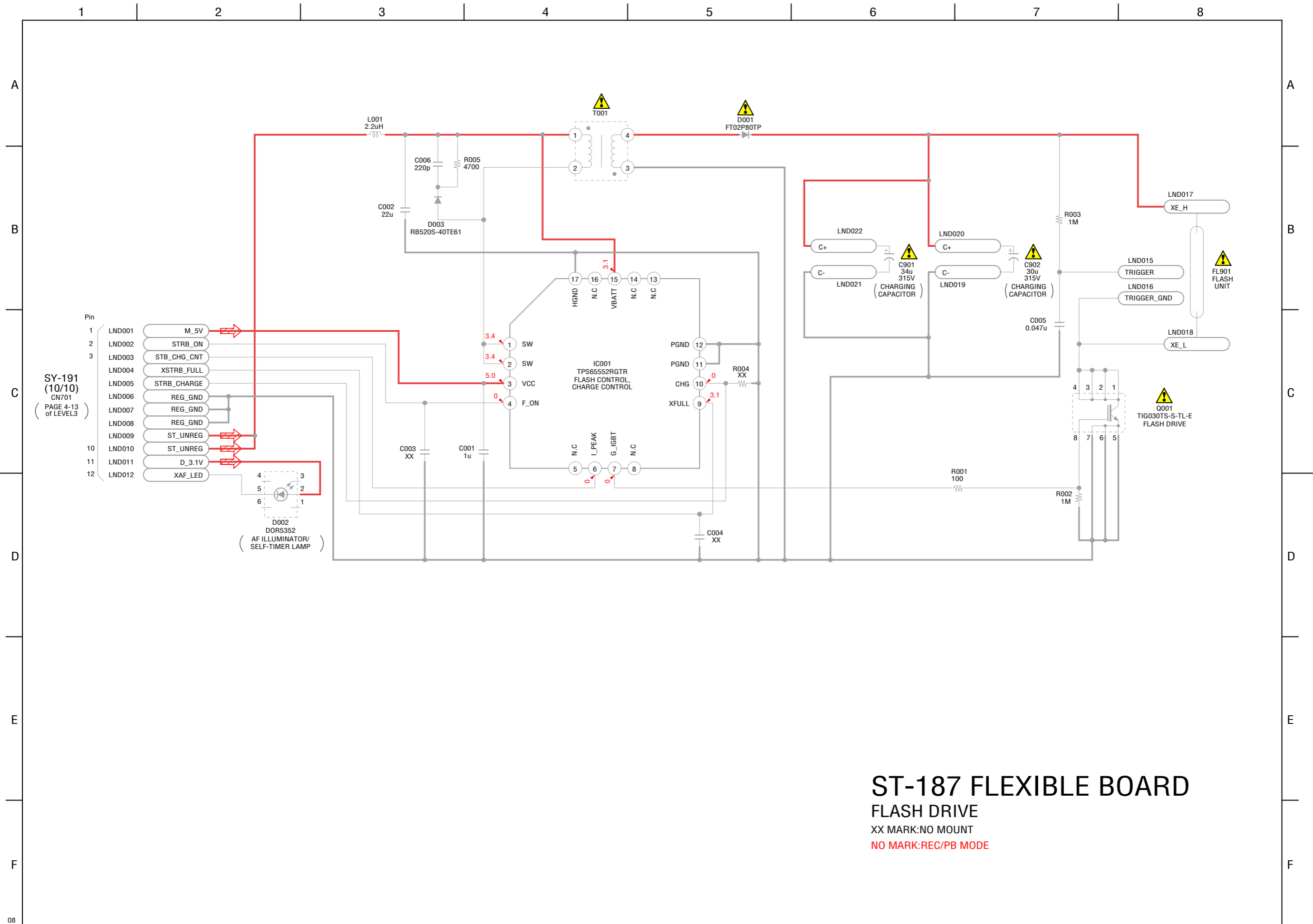

• Refer to page 4-2 for mark Δ .

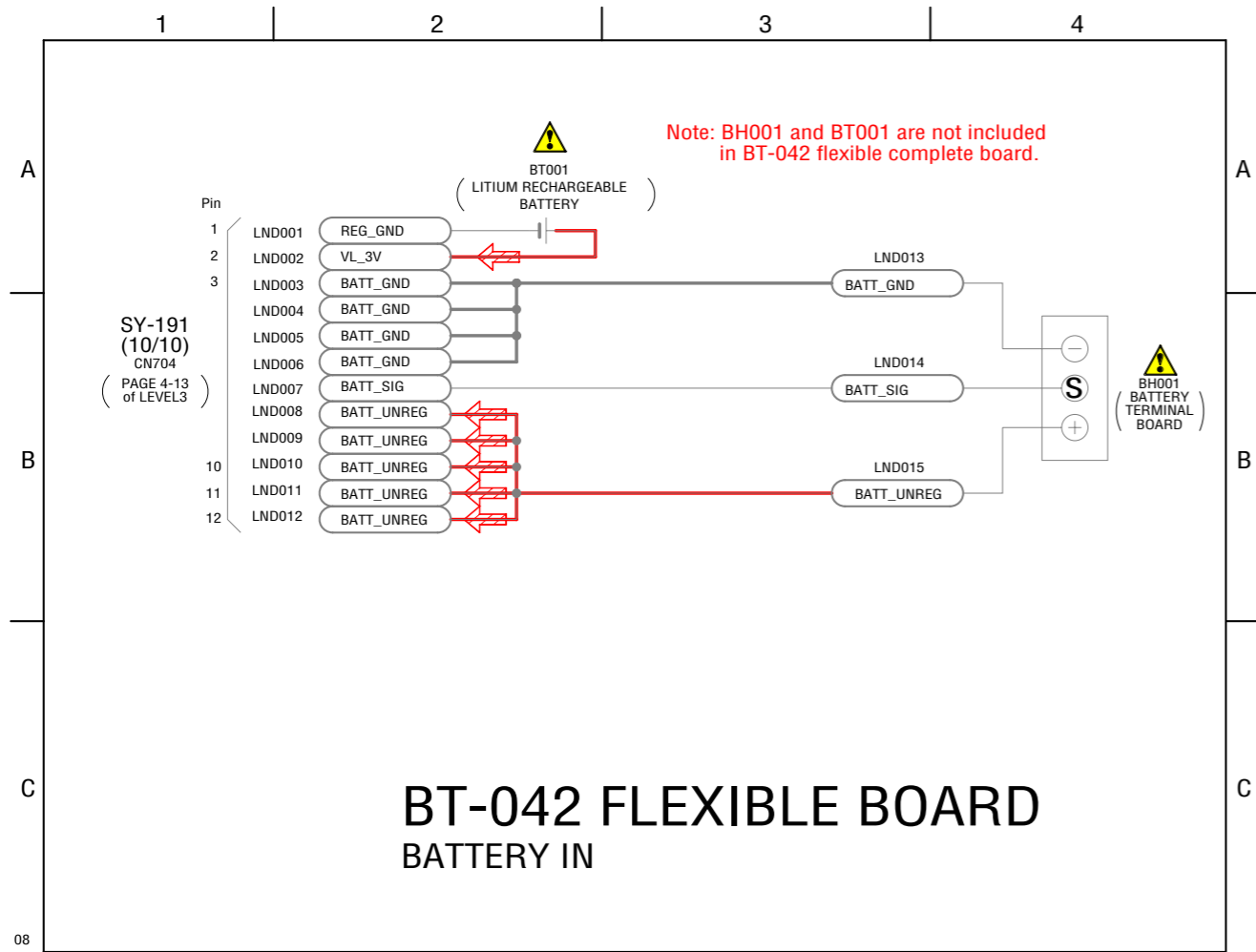

4-3. PRINTED WIRING BOARDS

Link

• [MC-190 FLEXIBLE BOARD](#)

• [ST-187 FLEXIBLE BOARD](#)

• [BT-042 FLEXIBLE BOARD](#)

• [COMMON NOTE FOR PRINTED WIRING BOARDS](#)

Printed wiring boards of the CD-717 flexible board and the SY-191 board are not shown.
Pages 4-19 and 4-21 are not shown.

 : Uses unleaded solder.

MC-190 FLEXIBLE BOARD

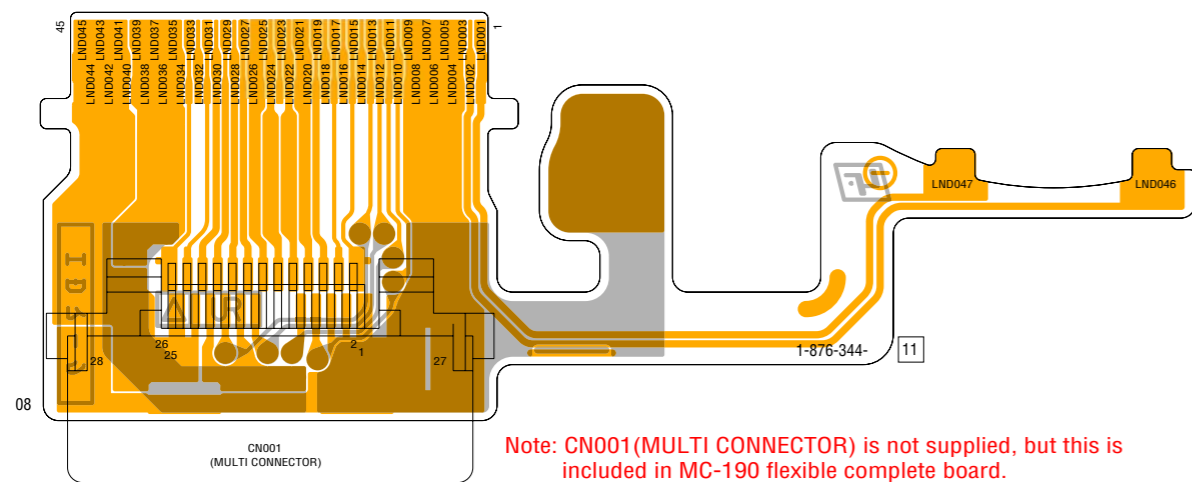

ST-187 FLEXIBLE BOARD

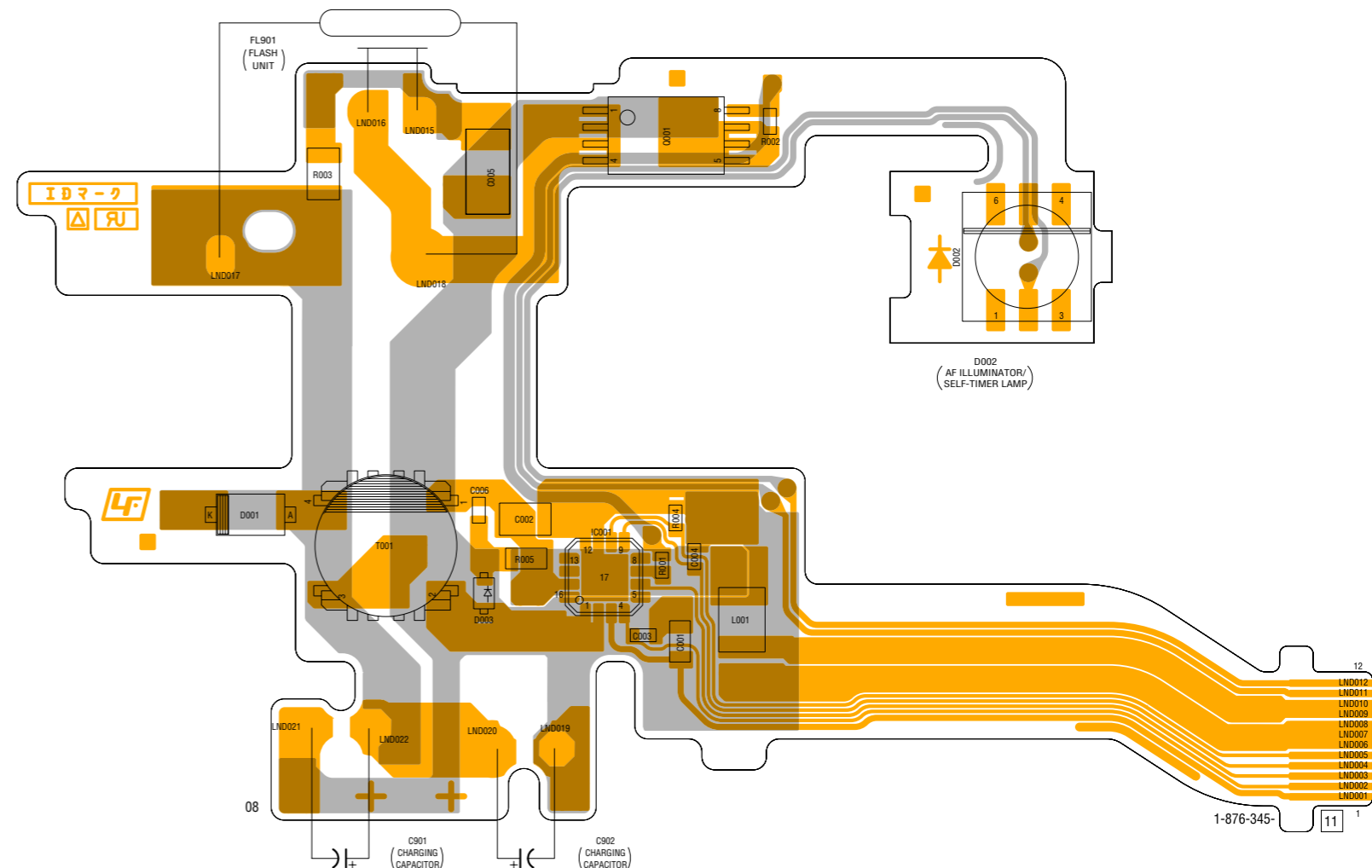

BT-042 FLEXIBLE BOARD

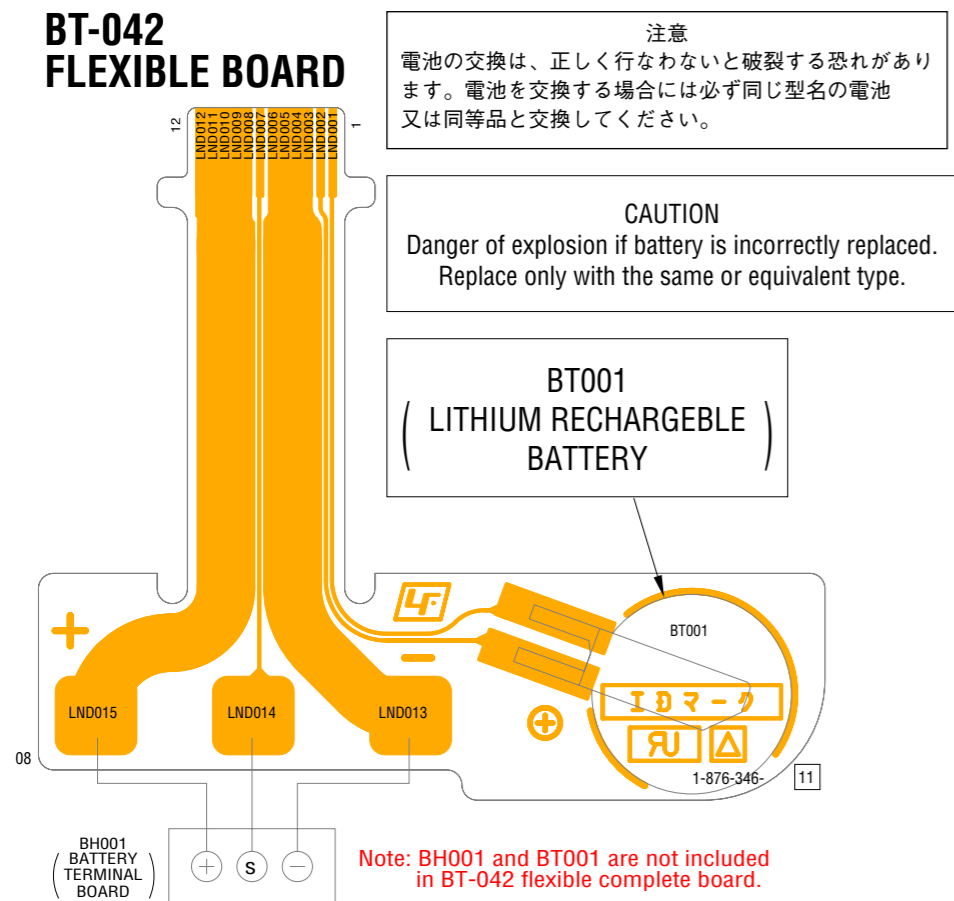

5. REPAIR PARTS LIST

NOTE: Characters **A** to **Z** of the electrical parts list indicate location of exploded views in which the desired part is shown.

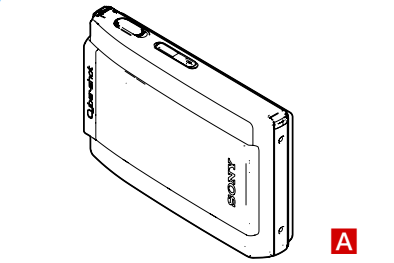
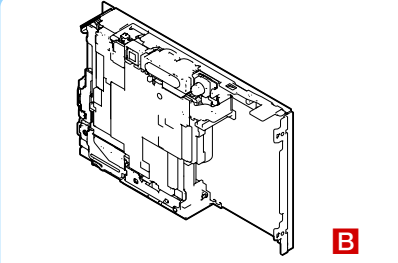
Link	EXPLODED VIEWS
 A	 B
OVERALL SECTION	CHASSIS SECTION

Link	ELECTRICAL PARTS LIST	ACCESSORIES
<ul style="list-style-type: none">BT-042 FLEXIBLE BOARD B	<ul style="list-style-type: none">ST-187 FLEXIBLE BOARD B	
<ul style="list-style-type: none">MC-190 FLEXIBLE BOARD B		

5. REPAIR PARTS LIST

5. REPAIR PARTS LIST

NOTE:

- -XX, -X mean standardized parts, so they may have some differences from the original one.
- Items marked "*" are not stocked since they are seldom required for routine service. Some delay should be anticipated when ordering these items.
- The mechanical parts with no reference number in the exploded views are not supplied.
- Due to standardization, replacements in the parts list may be different from the parts specified in the diagrams or the components used on the set.
- CAPACITORS:
 - uF: μ F
- COILS
 - uH: μ H
- RESISTORS
 - All resistors are in ohms.
 - METAL: metal-film resistor
 - METAL OXIDE: Metal Oxide-film resistor
 - F: nonflammable
- SEMICONDUCTORS
 - In each case, u: μ , for example:
 - uA...: μ A..., uPA..., μ PA...,
 - uPB..., μ PB..., μ PC..., μ PC...,
 - uPD..., μ PD...
- Abbreviation
 - AR : Argentine model
 - AUS : Australian model
 - BR : Brazilian model
 - CH : Chinese model
 - CND : Canadian model
 - EE : East European model
 - HK : Hong Kong model
 - J : Japanese model
 - JE : Tourist model
 - KR : Korea model
 - NE : North European model
 - TW : Taiwan model

When indicating parts by reference number, please include the board name.

The components identified by mark Δ or dotted line with mark Δ are critical for safety. Replace only with part number specified.

Les composants identifiés par une marque Δ sont critiques pour la sécurité. Ne les remplacer que par une pièce portant le numéro spécifié.

- Color Indication of Appearance Parts
 Example:
 (SILVER) : Cabinet's Color
 (Silver) : Parts Color

5. REPAIR PARTS LIST

DISASSEMBLY

HARDWARE LIST

5-1. EXPLODED VIEWS

5-1-1. OVERALL SECTION

Note 3 : This screw cannot be re-used, Discard the the screw removed once in servicing. Instead, use a new screw.

Note 3 : このネジは再利用することができません。サービス交換時に一度でも外した場合は新品のネジと交換してください。

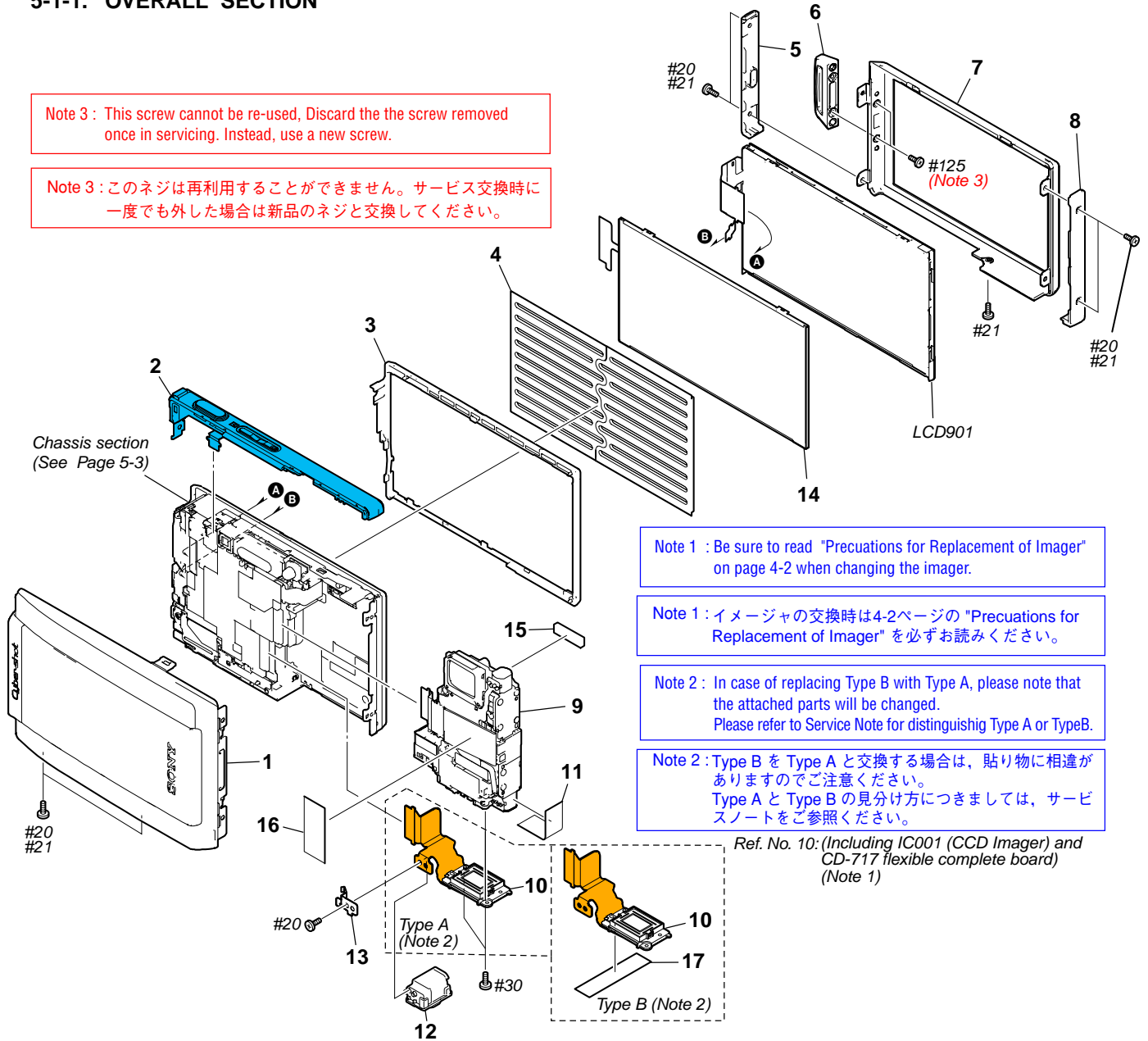

Note 1 : Be sure to read "Precautions for Replacement of Imager" on page 4-2 when changing the imager.

Note 1 : イメージャの交換時は4-2ページの "Precautions for Replacement of Imager" を必ずお読みください。

Note 2 : In case of replacing Type B with Type A, please note that the attached parts will be changed. Please refer to Service Note for distinguishing Type A or Type B.

Note 2 : Type B を Type A と交換する場合は、貼り物に相違がありますのでご注意ください。Type A と Type B の見分け方につきましては、サービスノートをご参照ください。

Ref. No. 10: (Including IC001 (CCD Imager) and CD-717 flexible complete board) (Note 1)

Ref. No.	Part No.	Description
1	X-2188-962-1	CABINET (FRONT) ASSY (MK) (BLACK)
1	X-2188-963-1	CABINET (FRONT) ASSY (MK) (RED)
1	X-2188-961-1	CABINET (FRONT) ASSY (MM) (SILVER)
2	A-1498-553-A	BLOCK, CABINET (UPPER) (RL-079) (SILVER)
2	A-1498-554-A	BLOCK, CABINET (UPPER) (RL-079) (BLACK)
2	A-1498-555-A	BLOCK, CABINET (UPPER) (RL-079) (RED)
3	3-293-734-01	HOLDER, LCD
4	3-293-733-01	CUSHION (LCD)
5	3-293-730-01	CABINET (SIDE L) (SILVER)
5	3-293-730-11	CABINET (SIDE L) (BLACK)
5	3-293-730-21	CABINET (SIDE L) (RED)
6	3-293-736-01	HOLDER, STRAP
7	3-293-735-01	CABINET (REAR)
8	3-293-729-01	CABINET (SIDE R) (SILVER)
8	3-293-729-11	CABINET (SIDE R) (BLACK)
8	3-293-729-21	CABINET (SIDE R) (RED)

Ref. No.	Part No.	Description
9	A-1236-991-A	LSV-1220A (SERVICE USE)
10	A-1539-407-A	CCD BLOCK ASSY (SERVICE) (Including IC001 (CCD Imager) and CD-717 flexible complete board) (Note 1)
11	3-293-744-01	SHEET (CD), LIGHT INTERCEPTION
12	3-293-731-01	SCREW, TRIPOD
* 13	3-293-739-01	PLATE (SY), GROUND
14	1-480-337-11	BLOCK, LIGHT GUIDE PLATE (3.5)
* 15	3-099-396-01	CUSHION, LENS
* 16	3-398-651-01	SHEET (LENS)
17	3-296-347-01	SHEET, LENS REINFORCEMENT
LCD901	A-1334-748-A	FTS BLOCK ASSY (35STMG07)
#20	2-635-591-31	M1.4 X 3.0 (Silver)
#21	2-662-396-21	M1.4 X 3.0 (Black)
#30	3-086-156-11	M1.2 X 3.5 (Tapping) (White)
#125	3-291-847-01	M1.4 X 3.0 (Black) (Note 3)

5. REPAIR PARTS LIST

DISASSEMBLY

HARDWARE LIST

5-1-2. CHASSIS SECTION

ns: not supplied

CAUTION

Danger of explosion if battery is incorrectly replaced.
Replace only with the same or equivalent type.

注意

電池の交換は、正しく行なわないと破裂する恐れがあります。電池を交換する場合には必ず同じ型名の電池又は同等品と交換してください。

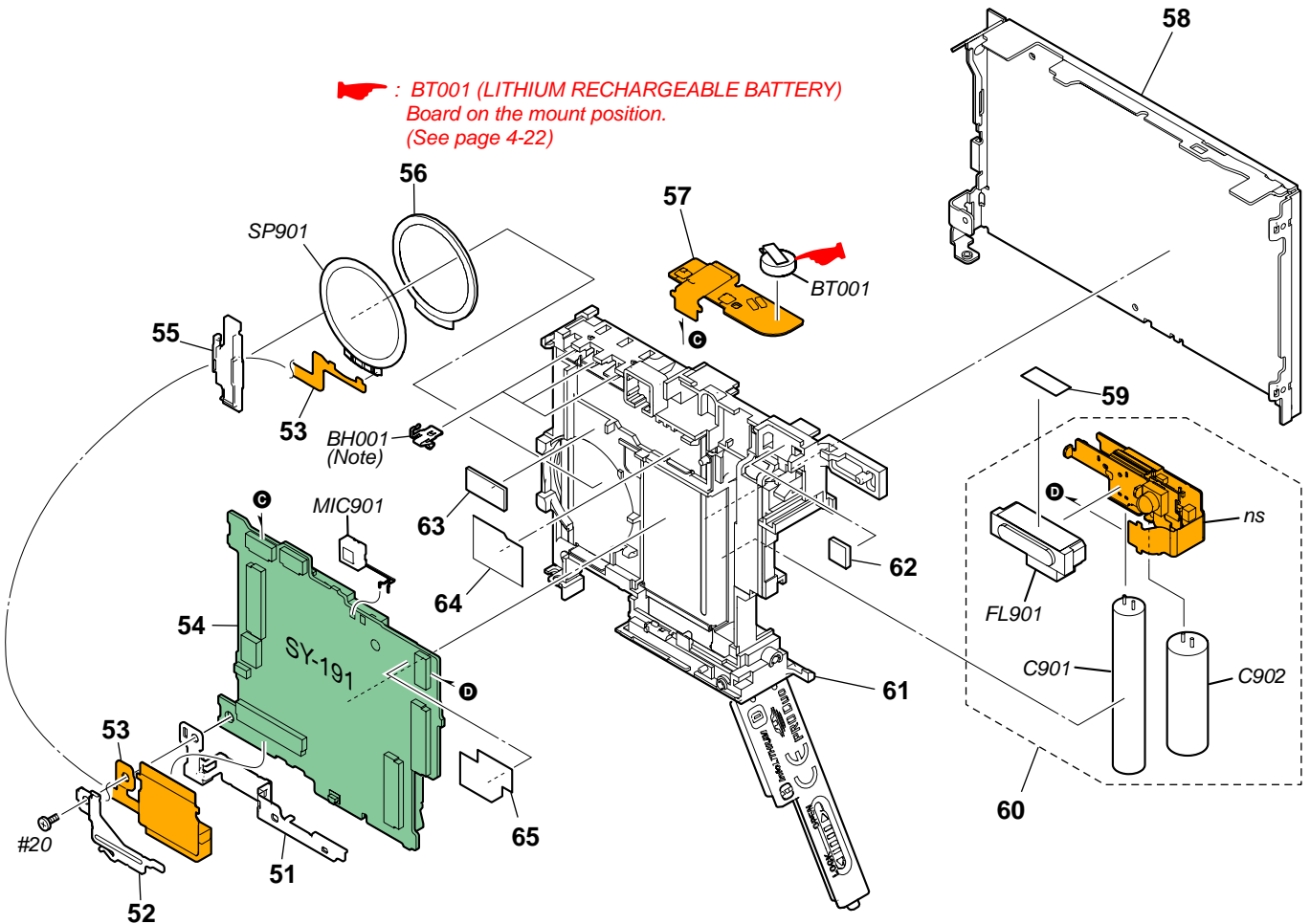

Note : BH001 is supplied by one piece.
Be sure to read "HELP04" when you install the BH001.

Note : BH001は一個ずつ供給されます。
BH001取付時は "HELP04"を必ずお読みください。

• Refer to page 5-1 for mark △.

Ref. No.	Part No.	Description
* 51	3-293-737-01	FRAME (MULTI)
* 52	3-293-738-01	SHEET METAL, MULTI RETAINER
53	A-1498-470-A	MC-190 FLEXIBLE BOARD, COMPLETE
54	A-1498-471-A	SY-191 BOARD, COMPLETE (SERVICE)
55	3-293-742-01	COVER (SP)
56	3-293-741-01	SHEET (SP), ADHESIVE
57	1-876-346-11	BT-042 FLEXIBLE BOARD
58	3-293-732-01	FRAME, MAIN
59	3-293-743-01	SHEET (ST), INSULATING
60	A-1498-469-A	ST-187 FLEXIBLE BOARD, COMPLETE
61	X-2188-993-1	HOLDER ASSY, BT
62	3-293-740-01	CUSHION (AF)

Ref. No.	Part No.	Description
* 63	3-870-734-01	CUSHION (SY)
* 64	3-874-262-01	SHEET (FM)
* 65	3-398-650-01	SHEET (SY)
△ BH001	1-780-456-31	TERMINAL BOARD, BATTERY (Note)
△ BT001	1-756-711-11	LITHIUM RECHARGEABLE BATTERY
△ *C901	1-114-622-11	CAP, ELECT 34MF 315V
△ *C902	1-114-621-11	CAP, ELECT 30MF 315V
△ FL901	1-480-599-11	FLASH UNIT
MIC901	1-542-757-31	MICROPHONE UNIT
SP901	1-826-759-11	BUZZER, PIEZOELECTRIC (2.0CM)
#20	2-635-591-31	M1.4 X 3.0 (Silver)

5-2. ELECTRICAL PARTS LIST

Ref. No.	Part No.	Description
	1-876-346-11	BT-042 FLEXIBLE BOARD *****

(BH001 and BT001 are not included in BT-042 flexible complete board.)

< BATTERY HOLDER >

△ BH001 1-780-456-31 TERMINAL BOARD, BATTERY

< BATTERY >

△ BT001 1-756-711-11 LITHIUM RECHARGEABLE BATTERY

Electrical parts list of the CD-717 flexible board is not shown.
Pages 5-5 is not shown.

CAUTION

Danger of explosion if battery is incorrectly replaced.
Replace only with the same or equivalent type.

注意

電池の交換は、正しく行わないと破裂する恐れがあります。電池を交換する場合には必ず同じ型名の電池又は同等品と交換してください。

• Refer to page 5-1 for mark △.

Ref. No.	Part No.	Description
	A-1498-470-A	MC-190 FLEXIBLE BOARD, COMPLETE *****

(CN001 is not supplied, but it is included in MC-190 complete flexible board.)

< CONNECTOR >

CN001	(Not supplied)	CONNECTOR, MULTIPLE (SOCKET)
-------	----------------	------------------------------

	A-1498-469-A	ST-187 FLEXIBLE BOARD, COMPLETE *****
--	--------------	--

< CAPACITOR >

C001	1-165-908-11	CERAMIC CHIP	1uF	10%	10V
C002	1-100-611-91	CERAMIC CHIP	22uF	20%	6.3V
C005	1-100-758-11	CERAMIC CHIP	0.047uF	10%	250V
C006	1-164-933-11	CERAMIC CHIP	220PF	10%	50V
△*C901	1-114-622-11	CAP, ELECT	34MF		315V
△*C902	1-114-621-11	CAP, ELECT	30MF		315V

< DIODE >

△ D001	6-501-141-01	DIODE FT02P80TP
* D002	6-501-364-01	DIODE DOR5352
D003	6-500-619-01	DIODE RB520S-40TE61

< FLASH UNIT >

△ FL901	1-480-599-11	FLASH UNIT
---------	--------------	------------

< IC >

IC001	6-707-555-01	IC TPS65552RGTR
-------	--------------	-----------------

< COIL >

* L001	1-400-820-11	INDUCTOR	2.2uH
--------	--------------	----------	-------

< TRANSISTOR >

△*Q001	6-551-686-01	TRANSISTOR	TIG030TS-S-TL-E
--------	--------------	------------	-----------------

< RESISTOR >

R001	1-218-941-81	RES-CHIP	100	5%	1/16W
R002	1-218-989-11	RES-CHIP	1M	5%	1/16W
R003	1-216-121-00	RES-CHIP	1M	5%	1/10W
R005	1-216-829-11	METAL CHIP	4.7K	5%	1/10W

< TRANSFORMER >

△ T001	1-445-108-21	TRANSFORMER, D.C-D.C CONVERTER
--------	--------------	--------------------------------

Electrical parts list of the SY-191 board is not shown.
Pages 5-7 to 5-10 are not shown.

• Refer to page 5-1 for mark △.

Checking supplied accessories.

Note 1: This item is supplied with the unit as an accessory, but is not prepared as a service part.



Power cord (mains lead)
(EXCEPT US, CND, J)
△ 1-833-892-21 (KR)
△ 1-824-910-71 (AEP, E)
△ 1-555-074-91 (AUS)
△ 1-792-549-41 (JE)
△ 1-783-952-61 (AR)
△ 1-832-121-31 (CH)
△ 1-827-269-12 (UK, HK)

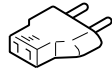

Conversion (2P) Adaptor
△ 1-569-007-12 (JE)



Conversion (2P) Adaptor
△ 1-569-008-12
(E (Except Middle East))

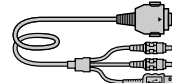

USB, A/V cable for
multi-use terminal
1-834-813-11

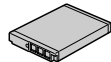

Rechargeable battery pack
(NP-BD1)
△ A-1310-294-A (J)
△ A-1310-295-A (US, CND)
△ A-1310-296-A (EXCEPT US, CND, CH, J)
△ A-1310-297-A (CH)



Instruction Manual
3-288-701-01 (JAPANESE) (J)
3-288-701-11 (ENGLISH) (CND, AEP, UK, AUS, E, HK, JE)
3-288-701-21 (FRENCH, ITALIAN) (CND, AEP)
3-288-701-31 (SPANISH, PORTUGUESE) (AEP, E, JE)
3-288-701-41 (GERMAN, DUTCH) (AEP)
3-288-701-51 (TRADITIONAL CHINESE,
SIMPLIFIED CHINESE) (E, HK, JE)
3-288-701-61 (RUSSIAN, UKRAINIAN) (AEP)
3-288-701-71 (ARABIC, PERSIAN) (E)
3-288-701-81 (KOREAN) (KR, JE)
3-288-701-91 (POLISH, CZECH) (AEP)
3-288-702-11 (HUNGARIAN, SLOVAK) (AEP)
3-288-702-21 (SWEDISH, FINNISH) (AEP)
3-288-702-31 (NORWEGIAN, DANISH) (AEP)
3-288-702-41 (THAI, MALAY) (E)
3-288-702-51 (TURKISH, GREEK) (AEP)
3-288-702-61 (ENGLISH, SPANISH) (US)
3-288-702-71 (SIMPLIFIED CHINESE) (CH)

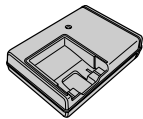

Battery charger
(BC-CSD)
△ 1-480-352-12 (J)
△ 1-480-352-22 (US, CND)
△ 1-480-352-32
(EXCEPT US, CND, J)

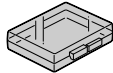

Battery case
(Note 1)



Wrist strap
2-050-981-01 (Gray) (SILVER Models)
2-050-981-11 (Black) (BLACK/RED Model)



Paint pen
2-888-952-01 (Black) (BLACK/RED Model)
2-888-952-11 (Gray) (SILVER Models)

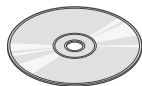

CD-ROM (Cyber-shot application software /
"Cyber-shot Handbook" / "Cyber-shot Step-up
Guide")
3-293-615-01



Cyber-shot Handbook (PDF)

The CD-ROM supplied contains all of language version of
the Instruction Manual in pdf (Cyber-shot Handbook.pdf) for printing.

- The printed matter is not supplied. If required,
please order it with the part number below.

- (Only for destination Japanese model)

日本国内については日本語のみが印刷での部品供給可能です。

- | | |
|--------------------------------------|----------------------------|
| * 3-288-698-01 (JAPANESE) | * 3-288-699-51 (POLISH) |
| * 3-288-698-11 (ENGLISH) | * 3-288-699-61 (CZECH) |
| * 3-288-698-21 (FRENCH) | * 3-288-699-71 (HUNGARIAN) |
| * 3-288-698-31 (ITALIAN) | * 3-288-699-81 (SLOVAK) |
| * 3-288-698-41 (SPANISH) | * 3-288-699-91 (SWEDISH) |
| * 3-288-698-51 (PORTUGUESE) | * 3-288-700-11 (FINNISH) |
| * 3-288-698-61 (GERMAN) | * 3-288-700-21 (NORWEGIAN) |
| * 3-288-698-71 (DUTCH) | * 3-288-700-31 (DANISH) |
| * 3-288-698-81 (TRADITIONAL CHINESE) | * 3-288-700-41 (THAI) |
| * 3-288-698-91 (SIMPLIFIED CHINESE) | * 3-288-700-51 (MALAY) |
| * 3-288-699-11 (RUSSIAN) | * 3-288-700-61 (TURKISH) |
| * 3-288-699-21 (ARABIC) | * 3-288-700-71 (GREEK) |
| * 3-288-699-31 (PERSIAN) | * 3-288-700-81 (UKRAINIAN) |
| * 3-288-699-41 (KOREAN) | |

• Refer to the page 5-1 for mark △.

HARDWARE LIST (1/7)

#1: M1.7 X 2.5
(Black)
2-635-562-11

#2: M1.7 X 4.0
(Black)
2-635-562-31

#3: M1.7 X 2.5
(Red)
2-660-401-01

#4: M1.4 X 2.5 (Tapping)
(Dark Silver)
3-348-998-81

#5: M1.7 X 3.5 (Tapping)
(Black)
3-080-204-01

#6: M1.4 X 1.7
(Silver)
2-598-474-01

#7: M1.7 X 1.6
(Black)
7-627-552-18

#8: M1.7 X 3.5 (Tapping)
(Silver)
3-078-890-01

#9: M1.7 X 5.0 (Tapping)
(Silver)
3-078-890-21

#10: M1.7 X 4.0
(Silver)
2-599-475-31

#11: M1.7 X 4.0 (Tapping)
(Silver)
3-078-890-11

#12: M1.7 X 5.0 (Tapping)
(Black)
3-080-204-21

#13: M1.7 X 2.5 (Tapping)
(Silver)
3-085-397-01

#14: M1.7 X 2.5
(Silver)
2-599-475-11

#15: M1.4 X 1.5
(Silver)
3-062-214-01

#16: M1.4 X 2.5
(Silver)
2-586-337-01

#17: M1.7 X 1.5
(Silver)
2-586-389-01

#18: M1.4 X 2.5
(Silver)
2-635-591-21

#19: M1.2 X 4.0 (Tapping)
(Red)
3-086-156-21

#20: M1.4 X 3.0
(Silver)
2-635-591-31

HARDWARE LIST (2/7)

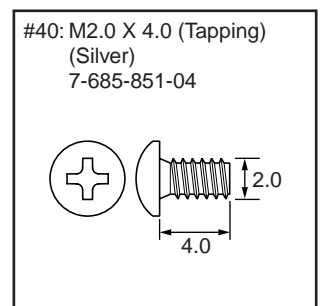
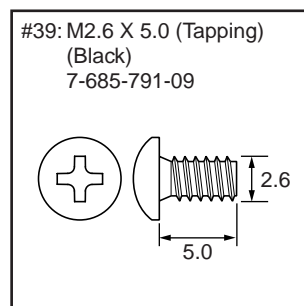
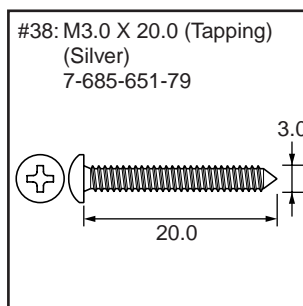
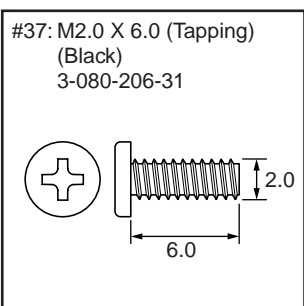
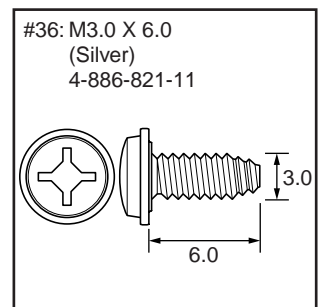
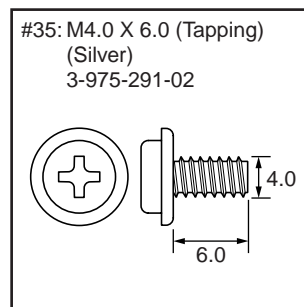
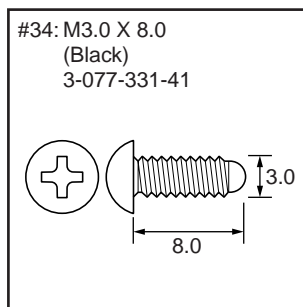
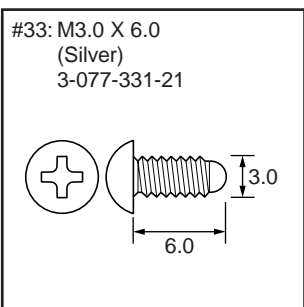
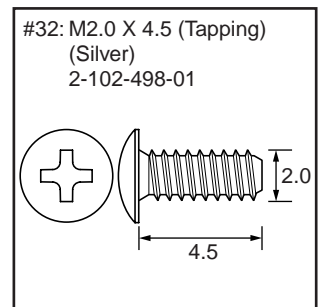
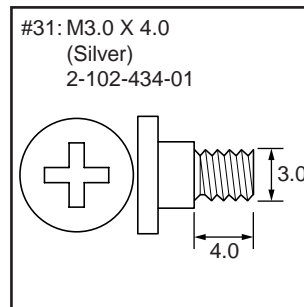
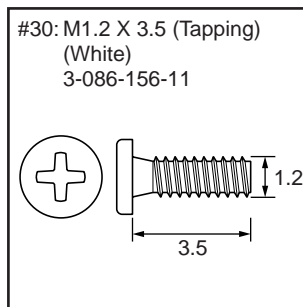
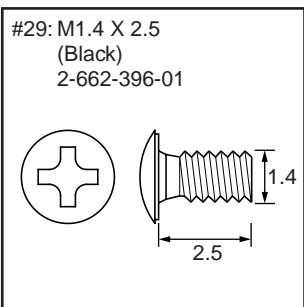
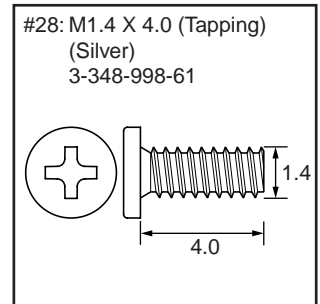
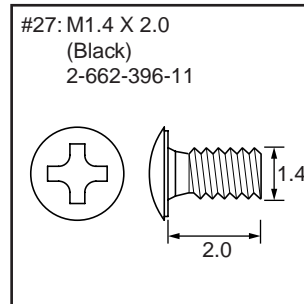
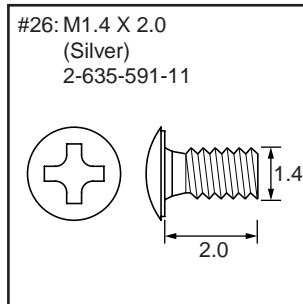
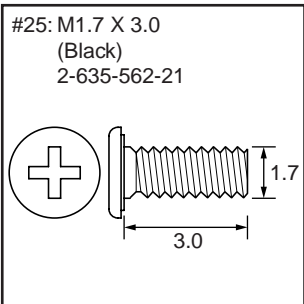
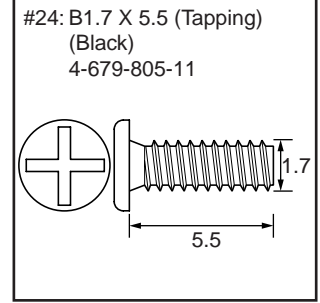
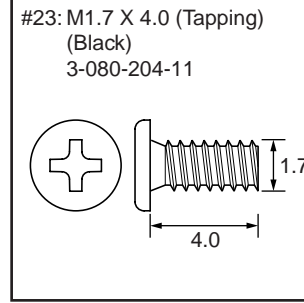
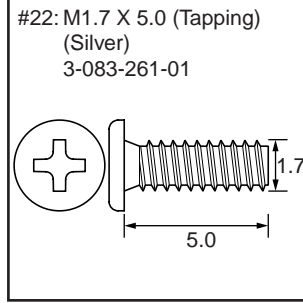
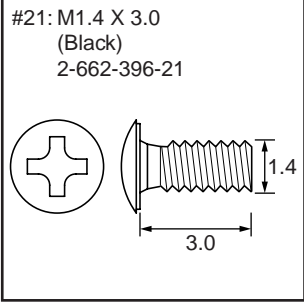

HARDWARE LIST (3/7)

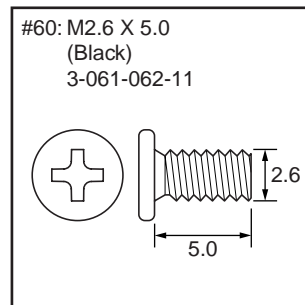
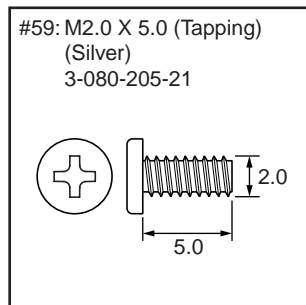
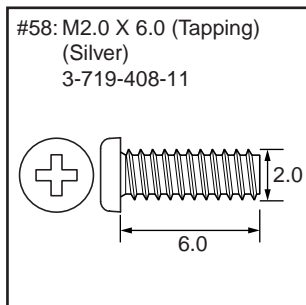
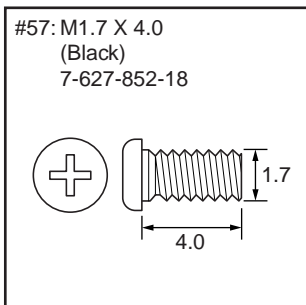
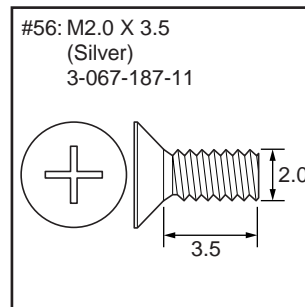
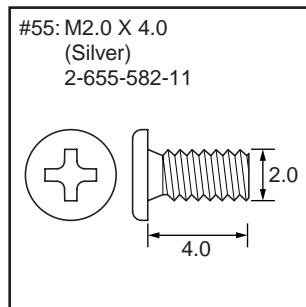
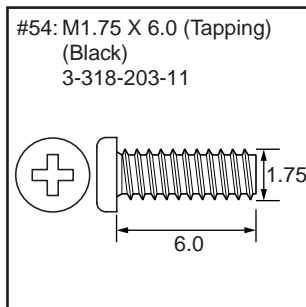
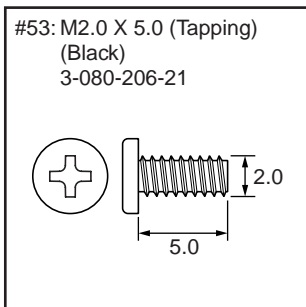
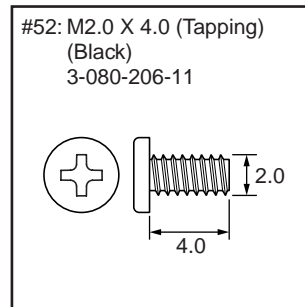
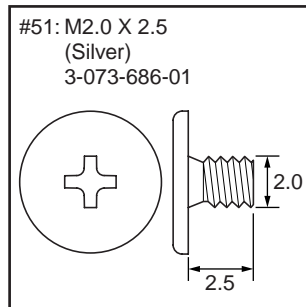
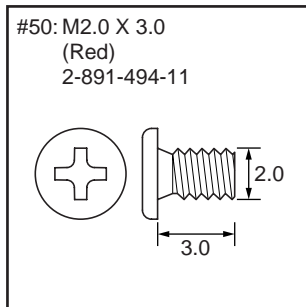
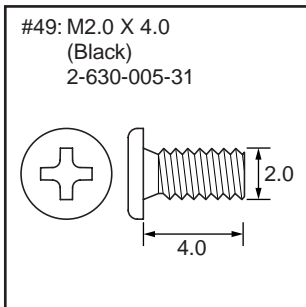
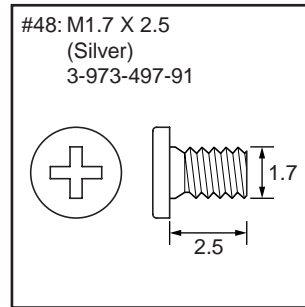
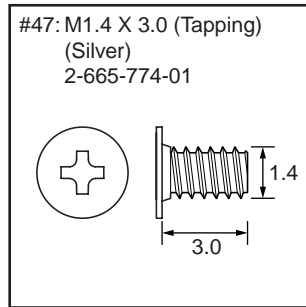
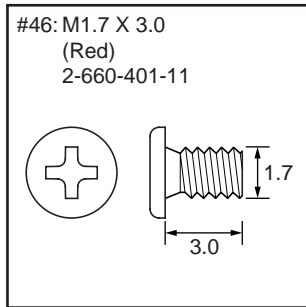
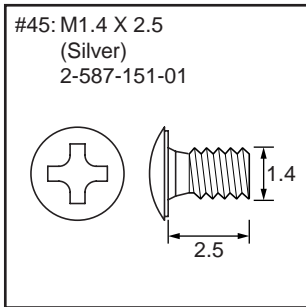
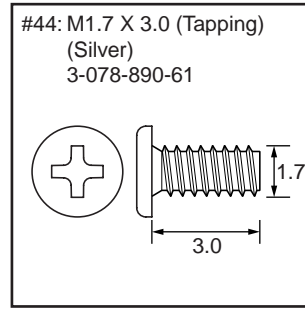
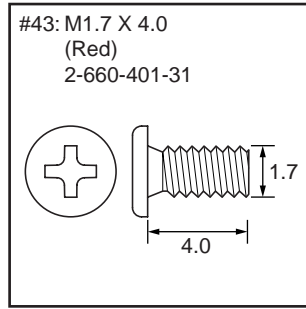
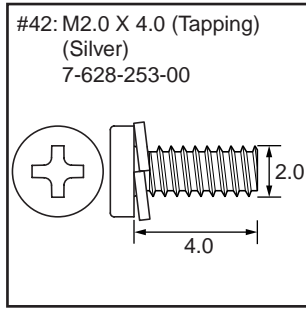
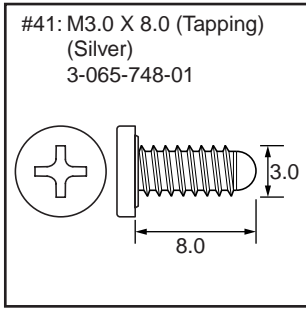

HARDWARE LIST (4/7)

#61: M3.0 X 10.0
(Black)
7-682-549-09

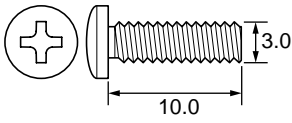

#62: M2.0 X 3.0
(Silver)
3-080-202-21

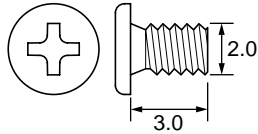

#63: M5.0 X 12.5
(Black)
3-060-811-21

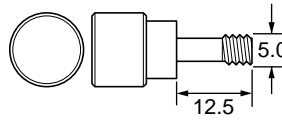

#64: M1.7 X 5.0 (Tapping)
(Silver)
2-666-551-21

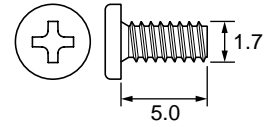

#65: M1.4 X 3.5
(Silver)
2-635-591-01

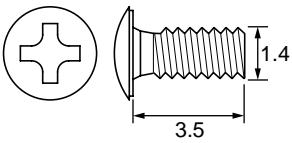

#66: M1.4 X 1.4
(Silver)
2-635-591-41

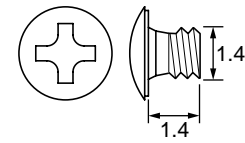

#67: M1.4 X 2.0
(Silver)
3-389-523-16

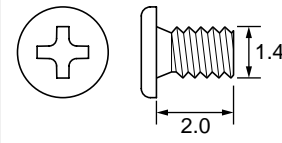

#68: M1.7 X 4.0
(Silver)
2-655-581-01

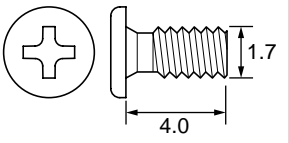

#69: M1.7 X 3.0
(Silver)
2-599-475-21

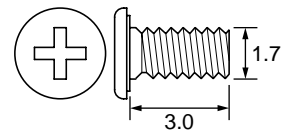

#70: M1.7 X 5.0
(Silver)
2-599-475-41

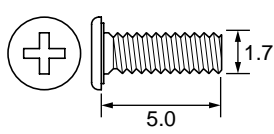

#71: M1.4 X 2.0
(Red)
3-208-537-01

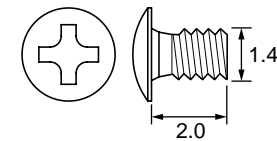

#72: M1.4 X 2.0
(Silver)
4-663-621-41

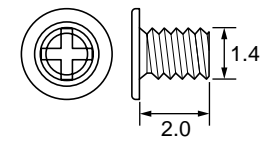

#73: M1.2 X 4.0 (Tapping)
(Black)
3-086-156-61

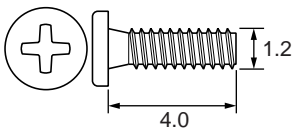

#74: M1.7 X 6.0 (Tapping)
(Silver)
2-666-551-31

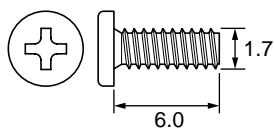

#75: M1.7 X 3.5 (Tapping)
(Silver)
2-666-551-01

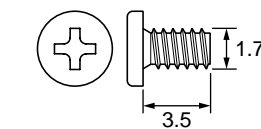

#76: M1.7 X 4.0 (Tapping)
(Silver)
2-666-551-11

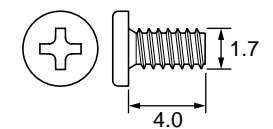

#77: M1.2 X 5.0 (Tapping)
(Silver)
3-086-156-31

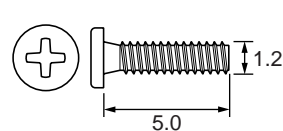

#78: M1.4 X 3.5
(Red)
3-208-537-11

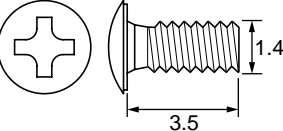

#79: M1.4 X 2.0
(Silver)
2-587-151-11

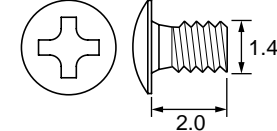

#80: M1.4 X 2.0
(Black)
3-279-411-01

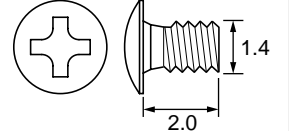

HARDWARE LIST (5/7)

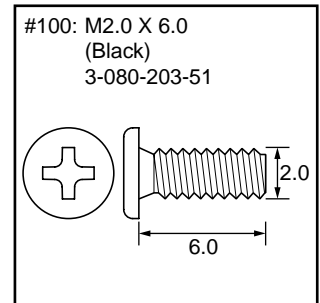
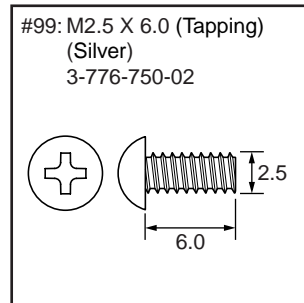
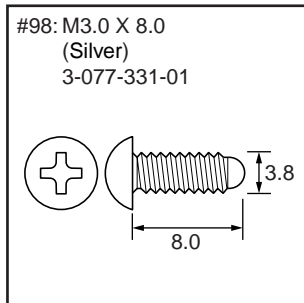
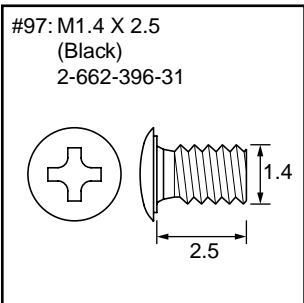
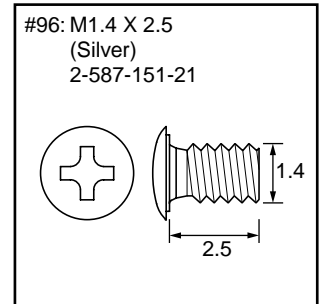
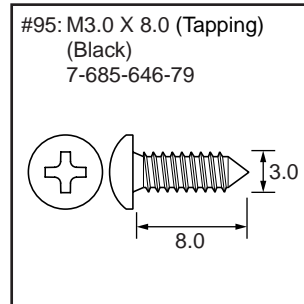
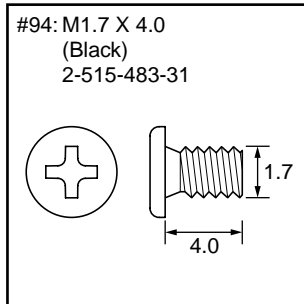
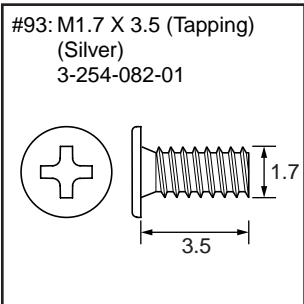
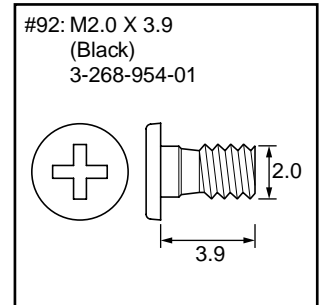
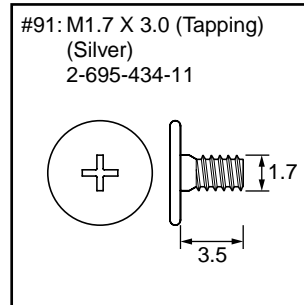
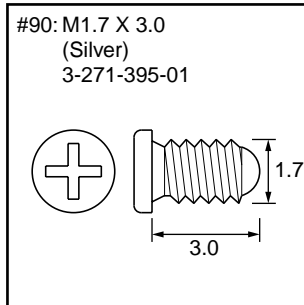
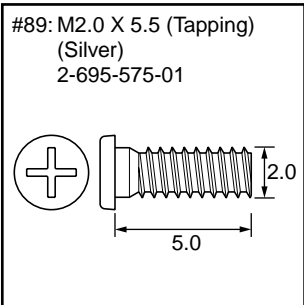
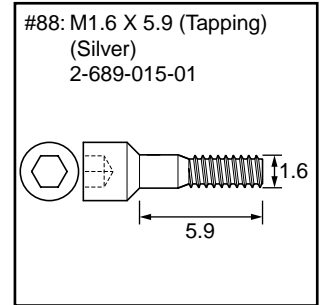
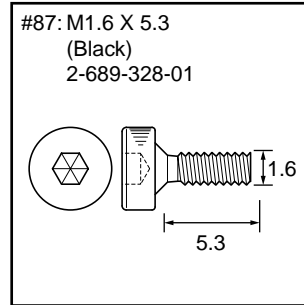
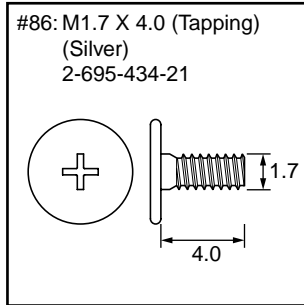
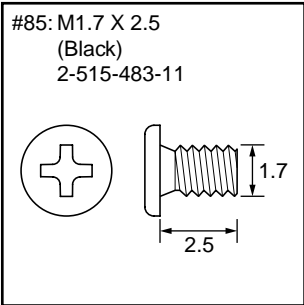
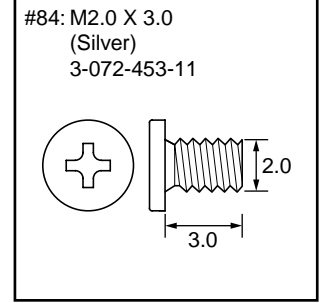
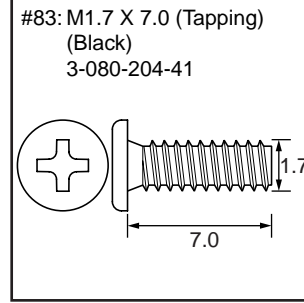
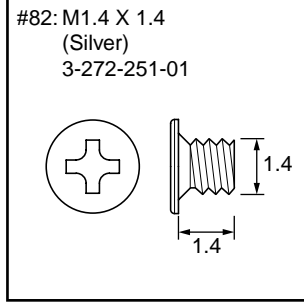
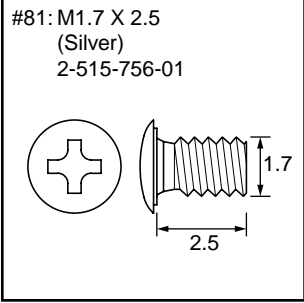

HARDWARE LIST (6/7)

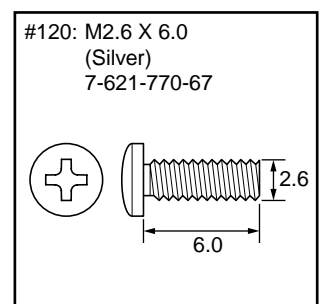
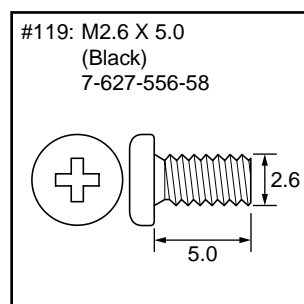
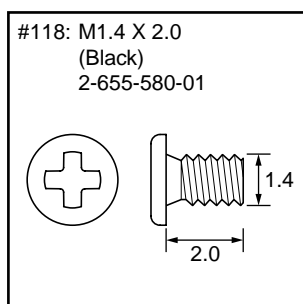
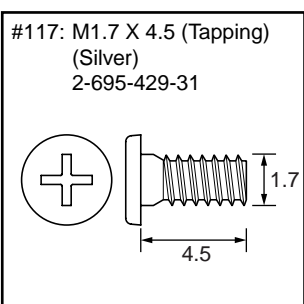
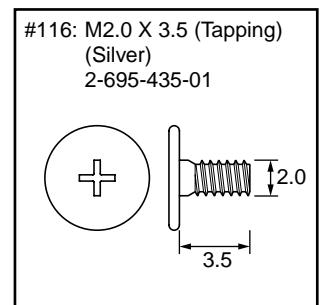
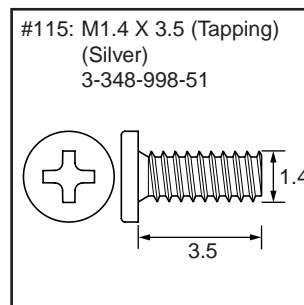
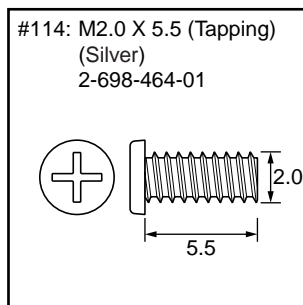
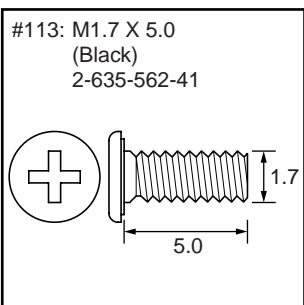
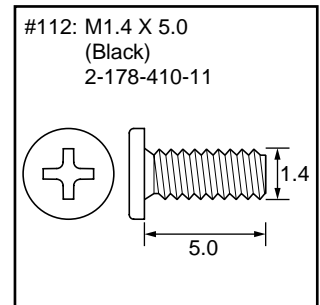
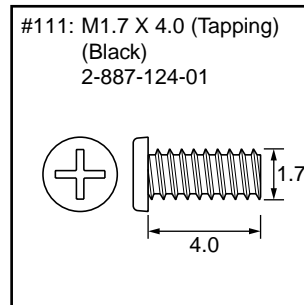
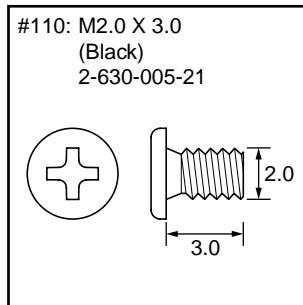
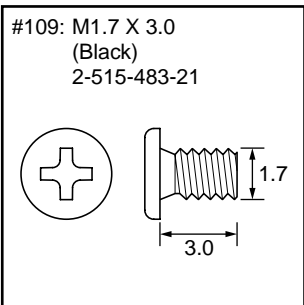
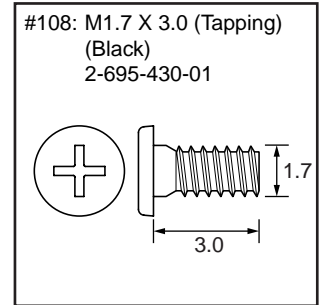
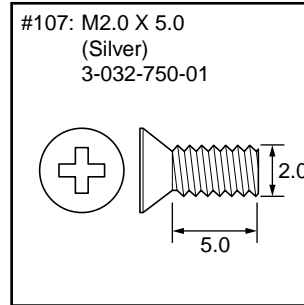
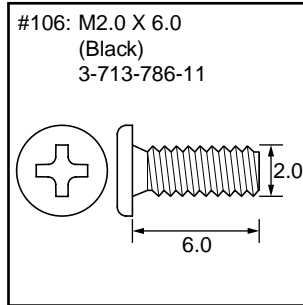
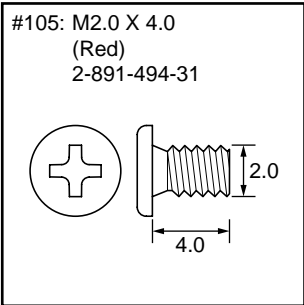
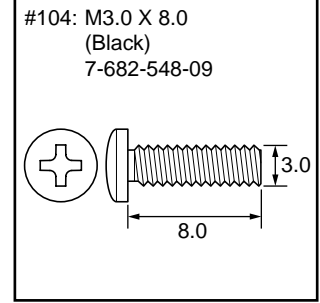
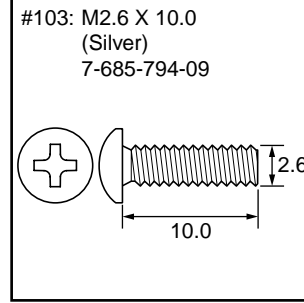
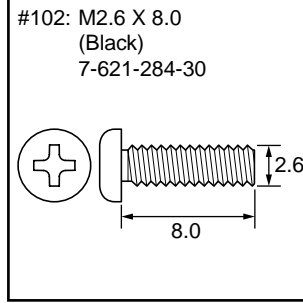
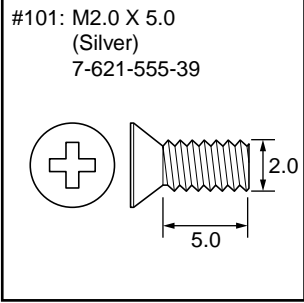

HARDWARE LIST (7/7)

#121: M2.0 X 4.0 (Tapping)
(Silver)
3-080-205-11

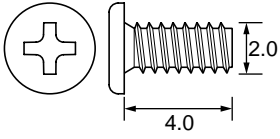

#122: M3.0 X 6.0
(Black)
7-682-547-09

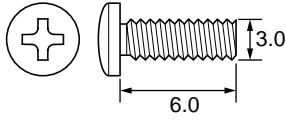

#123: M4.0 X 8.0
(Black)
7-682-561-09

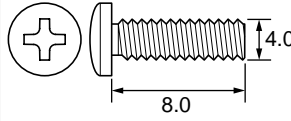

#124: M1.7 X 2.0
(Silver)
2-599-475-01

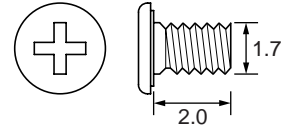

#125: M1.4 X 3.0
(Black)
3-291-847-01

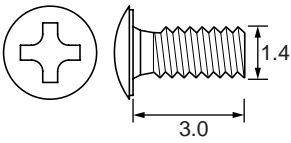

#126: M2.9 X 3.5
(Black)
3-292-616-01

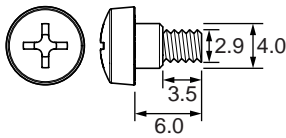

#127: M3.0 X 25.0
(Black)
7-682-654-09

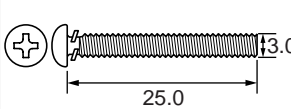

#128: M4.0 X 12.0
(Black)
3-452-472-01

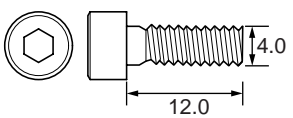

#129: M3.0 X 12.0
(Black)
7-682-550-09

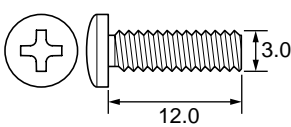

#130: M2.0 X 4.5 (Tapping)
(Silver)
3-732-817-11

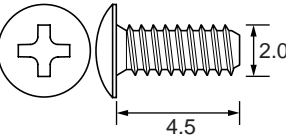

#131: M4.0 X 12.0
(Silver)
3-452-471-01

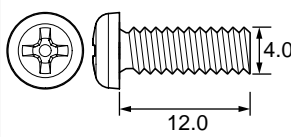

#132: M2.6 X 6.0
(Black)
4-673-655-01

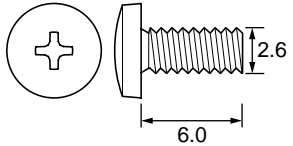

#133: M3.0 X 6.0
(Black)
3-452-484-01

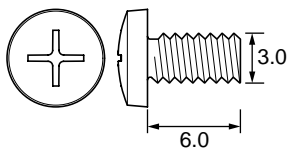

#134: M2.6 X 7.0
(Black)
3-299-572-01

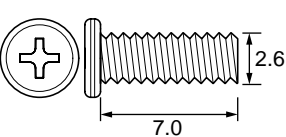

#135: M2.0 X 2.5
(Black)
7-627-553-28

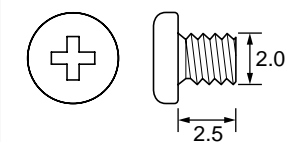

Revision History

Ver.	Date	History	Contents	S.M. Rev. issued
1.0	2008.02	Official Release	—	—