

DSC-T1

SERVICE MANUAL

LEVEL 2

Ver 1.3 2004.04

Revision History

How to use
Acrobat Reader



DSC-T1

US Model
Canadian Model
AEP Model
UK Model
E Model
Hong Kong Model
Australian Model
Korea Model
Chinese Model
Tourist Model
Japanese Model

Link

SPECIFICATIONS	BLOCK DIAGRAMS	PRINTED WIRING BOARDS
SERVICE NOTE	FRAME SCHEMATIC DIAGRAMS	REPAIR PARTS LIST
DISASSEMBLY	SCHEMATIC DIAGRAMS	

- For ADJUSTMENTS (SECTION 6), refer to SERVICE MANUAL, ADJ (987628053.pdf).
- For INSTRUCTION MANUAL, refer to SERVICE MANUAL, LEVEL 1 (987628043.pdf).
- Reference No. search on printed wiring boards is available.

On the LD-140, MS-148 and SY-95 boards

This service manual provides the information that is premised the circuit board replacement service and not intended repair inside the LD-140, MS-148 and SY-95 boards.

Therefore, schematic diagram, printed wiring board, waveforms, mounted parts location and electrical parts list of the LD-140, MS-148 and SY-95 boards are not shown.

The following pages are not shown.

Schematic diagram	Pages 4-15 to 4-36	Mounted parts location	Pages 4-54 to 4-55
Printed wiring board	Pages 4-45 to 4-52	Electrical parts list	Pages 5-7 to 5-11

DIGITAL STILL CAMERA

SONY[®]



Cyber-shot
Digital Still Camera



SPECIFICATIONS

■ Camera

[System]

Image device

7.66 mm (1/2.4 type) color CCD
Primary color filter

Total pixels number of camera

Approx. 5 255 000 pixels

Effective pixels number of camera

Approx. 5 090 000 pixels

Lens

Carl Zeiss Vario-Tessar
3× zoom lens
f = 6.7 – 20.1 mm (38 – 114 mm when converted to a 35 mm still camera)
F3.5 – 4.4

Exposure control

Automatic exposure, Scene selection
(8 modes)

White balance

Automatic, Daylight, Cloudy,
Fluorescent, Incandescent, Flash

File format (DCF compliant)

Still images: Exif Ver. 2.2 JPEG
compliant, DPOF compatible
Audio with still image: MPEG1
compliant (Monaural)
Movies: MPEG1 compliant
(Monaural)

Recording media

“Memory Stick Duo”

Flash

Recommended distance (ISO set to Auto):
0.3 m to 1.5 m (11 7/8 inches to 59 1/8 inches) (W)
0.5 m to 1.5 m (19 3/4 inches to 59 1/8 inches) (T)

[Input and Output connectors]

Multi connector

[LCD screen]

LCD panel

6.2 cm (2.5 type) TFT drive

Total number of dots

211200 (960×220) dots

[General]

Used battery pack

NP-FT1

Power requirements

3.6 V

Power consumption (during shooting)

1.6 W

Operating temperature

0°C to +40°C (+32°F to +104°F)

Storage temperature

–20°C to +60°C (–4°F to +140°F)

Dimensions

91 × 60 × 21 mm
(3 5/8 × 2 3/8 × 2 7/32 inches)
(W/H/D, excluding maximum protrusions)

Mass

Approx. 180 g (6.3 oz) (including battery pack NP-FT1, “Memory Stick Duo” and wrist strap)

Built-in microphone

Electret condenser microphone

Built-in speaker

Piezo-electric speaker

Exif Print Compatible

PRINT Image Matching II Compatible

■ UC-TA USB cradle

[Input and Output connectors]

A/V OUT (MONO) jack (Monaural)

Minijack
Video: 1 Vp-p, 75Ω, unbalanced, sync negative
Audio: 327 mV (at a 47 kΩ load)
Output impedance 1 kΩ

USB jack B

USB connection

High-Speed USB
(USB 2.0 High-Speed compatible)

DC IN jack

Camera connector

■ AC-LM5 AC Adaptor

Power requirements

100 to 240 V AC, 50/60 Hz

Current consumption

0.2 A

Power consumption

10 W

Rated output voltage

4.2 V DC, 1.5 A

Operating temperature

0°C to +40°C (+32°F to +104°F)

Storage temperature

–20°C to +60°C (–4°F to +140°F)

Dimensions

Approx. 47 × 30 × 80 mm
(1 7/8 × 1 3/16 × 3 1/4 inches)
(W/H/D, excluding projecting parts)

Mass

Approx. 170 g (6.0 oz) excluding power cord (mains lead)

■ NP-FT1 battery pack

Used battery

Lithium-ion battery

Maximum voltage

DC 4.2 V

Nominal voltage

DC 3.6 V

Capacity 2.4 Wh (680 mAh)

■ Accessories

- AC-LM5 AC Adaptor (1)
- Power cord (mains lead) (1)
- UC-TA USB cradle (1)
- USB cable (1)
- NP-FT1 battery pack (1)
- A/V connecting cable (1)
- Wrist strap (1)
- “Memory Stick Duo” (32 MB) (1)
- Memory Stick Duo Adaptor (1)
- CD-ROM (USB driver SPVD-013) (1)
- Operating instructions (1)

Design and specifications are subject to change without notice.

CAUTION :

Danger of explosion if battery is incorrectly replaced.
Replace only with the same or equivalent type.

SAFETY-RELATED COMPONENT WARNING!!

COMPONENTS IDENTIFIED BY MARK \triangle OR DOTTED LINE WITH MARK \triangle ON THE SCHEMATIC DIAGRAMS AND IN THE PARTS LIST ARE CRITICAL TO SAFE OPERATION. REPLACE THESE COMPONENTS WITH SONY PARTS WHOSE PART NUMBERS APPEAR AS SHOWN IN THIS MANUAL OR IN SUPPLEMENTS PUBLISHED BY SONY.

ATTENTION AU COMPOSANT AYANT RAPPORT À LA SÉCURITÉ!

LES COMPOSANTS IDENTIFIÉS PAR UNE MARQUE \triangle SUR LES DIAGRAMMES SCHÉMATIQUES ET LA LISTE DES PIÈCES SONT CRITIQUES POUR LA SÉCURITÉ DE FONCTIONNEMENT. NE REMPLACER CES COMPOSANTS QUE PAR DES PIÈCES SONY DONT LES NUMÉROS SONT DONNÉS DANS CE MANUEL OU DANS LES SUPPLÉMENTS PUBLIÉS PAR SONY.

SAFETY CHECK-OUT

After correcting the original service problem, perform the following safety checks before releasing the set to the customer.

1. Check the area of your repair for unsoldered or poorly-soldered connections. Check the entire board surface for solder splashes and bridges.
2. Check the interboard wiring to ensure that no wires are "pinched" or contact high-wattage resistors.
3. Look for unauthorized replacement parts, particularly transistors, that were installed during a previous repair. Point them out to the customer and recommend their replacement.
4. Look for parts which, through functioning, show obvious signs of deterioration. Point them out to the customer and recommend their replacement.
5. Check the B+ voltage to see it is at the values specified.
6. Flexible Circuit Board Repairing
 - Keep the temperature of the soldering iron around 270°C during repairing.
 - Do not touch the soldering iron on the same conductor of the circuit board (within 3 times).
 - Be careful not to apply force on the conductor when soldering or unsoldering.

Unleaded solder

Boards requiring use of unleaded solder are printed with the lead-free mark (LF) indicating the solder contains no lead.

(Caution: Some printed circuit boards may not come printed with the lead free mark due to their particular size.)

**: LEAD FREE MARK**

Unleaded solder has the following characteristics.

- Unleaded solder melts at a temperature about 40°C higher than ordinary solder.
Ordinary soldering irons can be used but the iron tip has to be applied to the solder joint for a slightly longer time.
Soldering irons using a temperature regulator should be set to about 350°C.
Caution: The printed pattern (copper foil) may peel away if the heated tip is applied for too long, so be careful!
- Strong viscosity
Unleaded solder is more viscous (sticky, less prone to flow) than ordinary solder so use caution not to let solder bridges occur such as on IC pins, etc.
- Usable with ordinary solder
It is best to use only unleaded solder but unleaded solder may also be added to ordinary solder.

TABLE OF CONTENTS

1. SERVICE NOTE 1-1

2. DISASSEMBLY

2-1. DISASSEMBLY 2-1

2-2. SERVICE POSITION 2-3

2-3. CIRCUIT BOARDS LOCATION 2-5

2-4. FLEXIBLE BOARDS LOCATION 2-5

HELP (List of caution points is shown here.)

3. BLOCK DIAGRAMS

3-1. OVERALL BLOCK DIAGRAM (1/2) 3-1

3-2. OVERALL BLOCK DIAGRAM (2/2) 3-3

3-3. POWER BLOCK DIAGRAM (1/2) 3-5

3-4. POWER BLOCK DIAGRAM (2/2) 3-7

4. PRINTED WIRING BOARDS AND SCHEMATIC DIAGRAMS

4-1. FRAME SCHEMATIC DIAGRAM (1/2) 4-1

FRAME SCHEMATIC DIAGRAM (2/2) 4-3

4-2. SCHEMATIC DIAGRAMS

- CD-463 (CCD IMAGER)
SCHEMATIC DIAGRAM 4-7
- CN-198 (MULTI CONNECTOR)
SCHEMATIC DIAGRAM 4-9
- ST-86 (FLASH)
SCHEMATIC DIAGRAM 4-11
- CONTROL SWITCH BLOCK (PW-125)
SCHEMATIC DIAGRAM 4-13

Schematic diagram of the SY-95, MS-148 and LD-140 boards are not shown.
Pages from 4-15 to 4-36 are not shown.

4-3. PRINTED WIRING BOARDS

- CD-463 (CCD IMAGER)
PRINTED WIRING BOARD 4-41
- ST-86 (FLASH)
PRINTED WIRING BOARD 4-42
- CN-198 (MULTI CONNECTOR)
PRINTED WIRING BOARD 4-43

Printed wiring board of the SY-95, MS-148, LD-140 and FP-694 boards are not shown.
Pages from 4-45 to 4-52 are not shown.

4-4. MOUNTED PARTS LOCATION 4-53

Mounted parts location of the SY-95, MS-148 and FP-695 boards are not shown.
Pages from 4-54 to 4-55 are not shown.

5. REPAIR PARTS LIST

5-1. EXPLODED VIEWS 5-1

5-1-1. OVERALL SECTION 5-3

5-1-2. BATTERY HOLDER SECTION 5-4

5-1-3. CABINET (REAR) SECTION 5-5

5-2. ELECTRICAL PARTS LIST 5-6

Parts list of the SY-95, MS-148 and LD-140 boards are not shown.
Pages from 5-7 to 5-11 are not shown.

SECTION 1 SERVICE NOTE

• NOTE FOR REPAIR

Make sure that the flat cable and flexible board are not cracked or bent at the terminal.
Do not insert the cable insufficiently nor crookedly.

When remove a connector, don't pull at wire of connector.
Be in danger of the snapping of a wire.

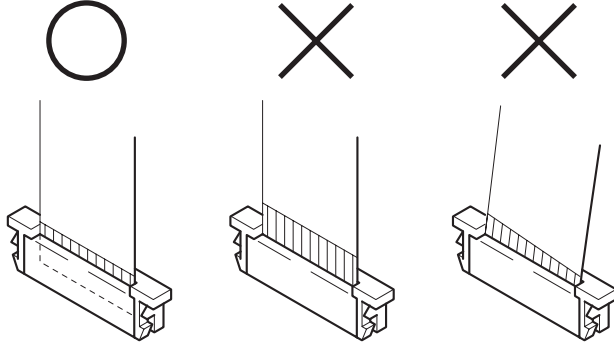

When installing a connector, don't press down at wire of connector.
Be in danger of the snapping of a wire.

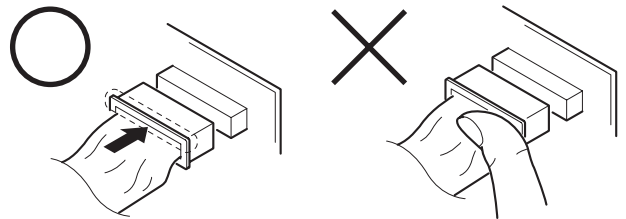

Cut and remove the part of gilt which comes off at the point.
(Take care that there are some pieces of gilt left inside)

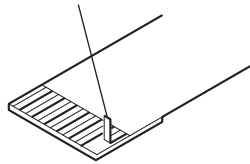

[Discharging of the FLASH unit's charging capacitor]

The charging capacitor of the FLASH unit is charged up to the maximum 300 V potential.

There is a danger of electric shock by this high voltage when the capacitor is handled by hand. The electric shock is caused by the charged voltage which is kept without discharging when the main power of the DSC-T1 is simply turned off. Therefore, the remaining voltage must be discharged as described below.

Preparing the Short Jig

To preparing the short jig, a small clip is attached to each end of a resistor of 1 k Ω / 1 W (1-215-869-11)

Wrap insulating tape fully around the leads of the resistor to prevent electrical shock.

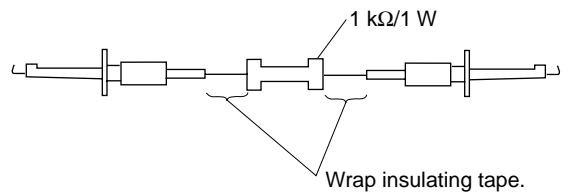

Discharging the Capacitor

Short circuits between the positive and the negative terminals of charged capacitor with the short jig about 10 seconds.

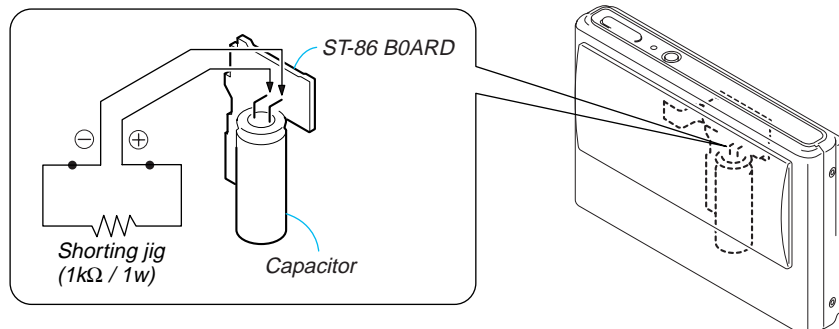

[Description on Self-diagnosis Display]

Self-diagnosis display

The camera has a self-diagnosis display. This function displays the camera condition with five-digits (a combination of a letter and figures) on the LCD screen. If this occurs check the following code chart. The five-digits display informs you of the camera's current condition. The last two digits (indicated by □□) will differ depending on the state of the camera.

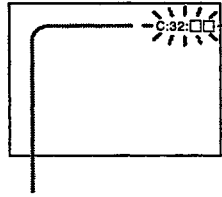

Self-diagnosis display

- C: □□: □□
The contents which can be handled by customer, are displayed.
- E: □□: □□
The contents which can be handled by engineer, are displayed.

Display Code	Countermeasure	Cause	Caution Display During Error
C:32:01	Turn off the main power then back on.	Trouble with hardware.	SYSTEM ERROR
C:13:01	Replace the memory stick. Format the memory stick with the DSC-T1.	<ul style="list-style-type: none"> • The type of memory stick that cannot be used by this machine, is inserted. • Data is damaged. • Unformatted memory stick is inserted. 	MS ERROR
E:91:01	Checking of flash unit or replacement of flash unit.	Abnormality when flash is being charged.	Flash LED Flash display Flashing at 3.2 Hz
E:01:XX	Checking of lens drive circuit	When failed in the focus initialization.	—
E:61:00 *1			
E:61:10 *1			

Note : The error code is cleared if the battery is removed, except defective flash unit.

*1: The error display is given in two ways.

SECTION 2 DISASSEMBLY

The following flow chart shows the disassembly procedure.

2-1. DISASSEMBLY

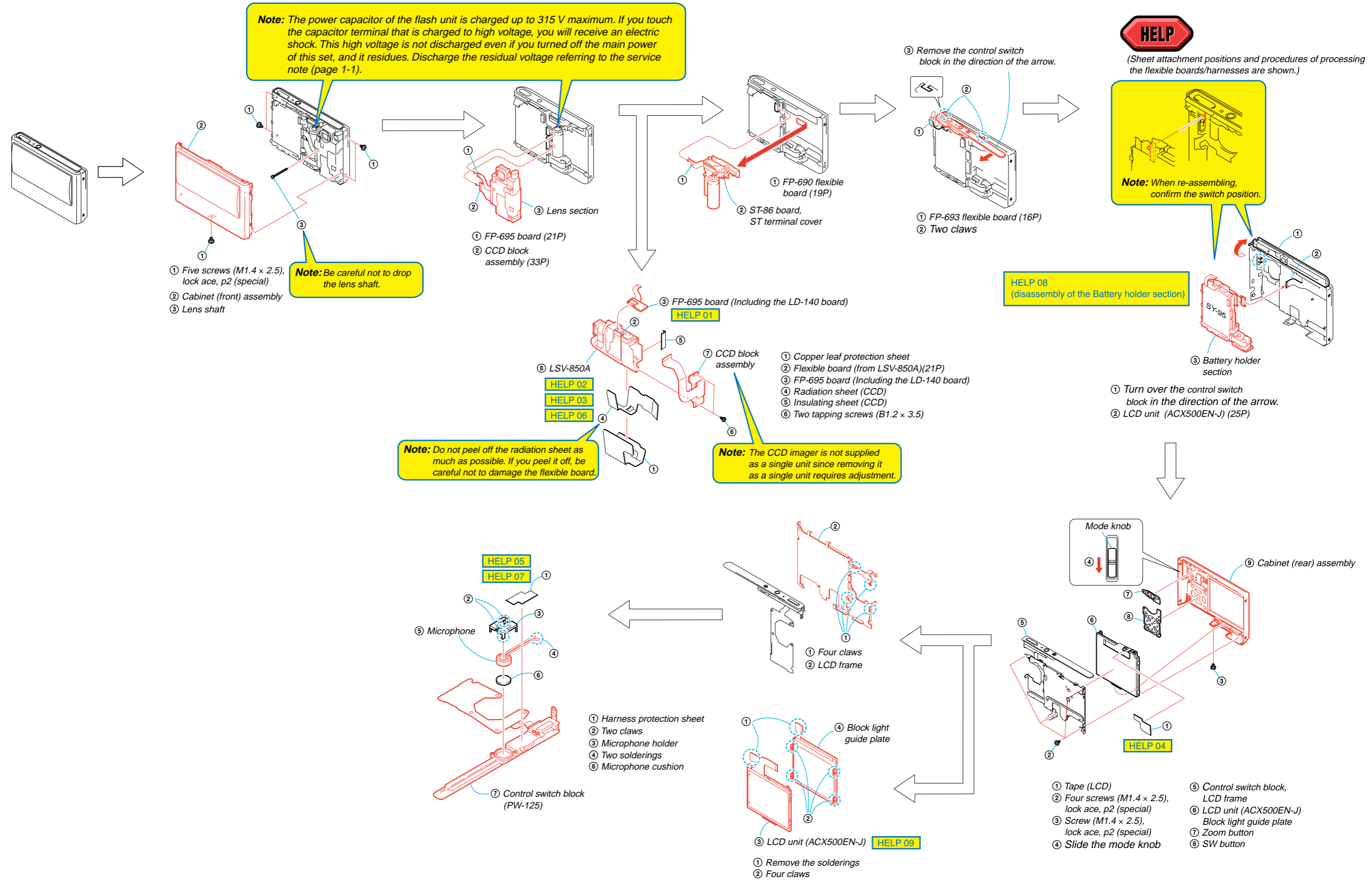

2-2. SERVICE POSITION

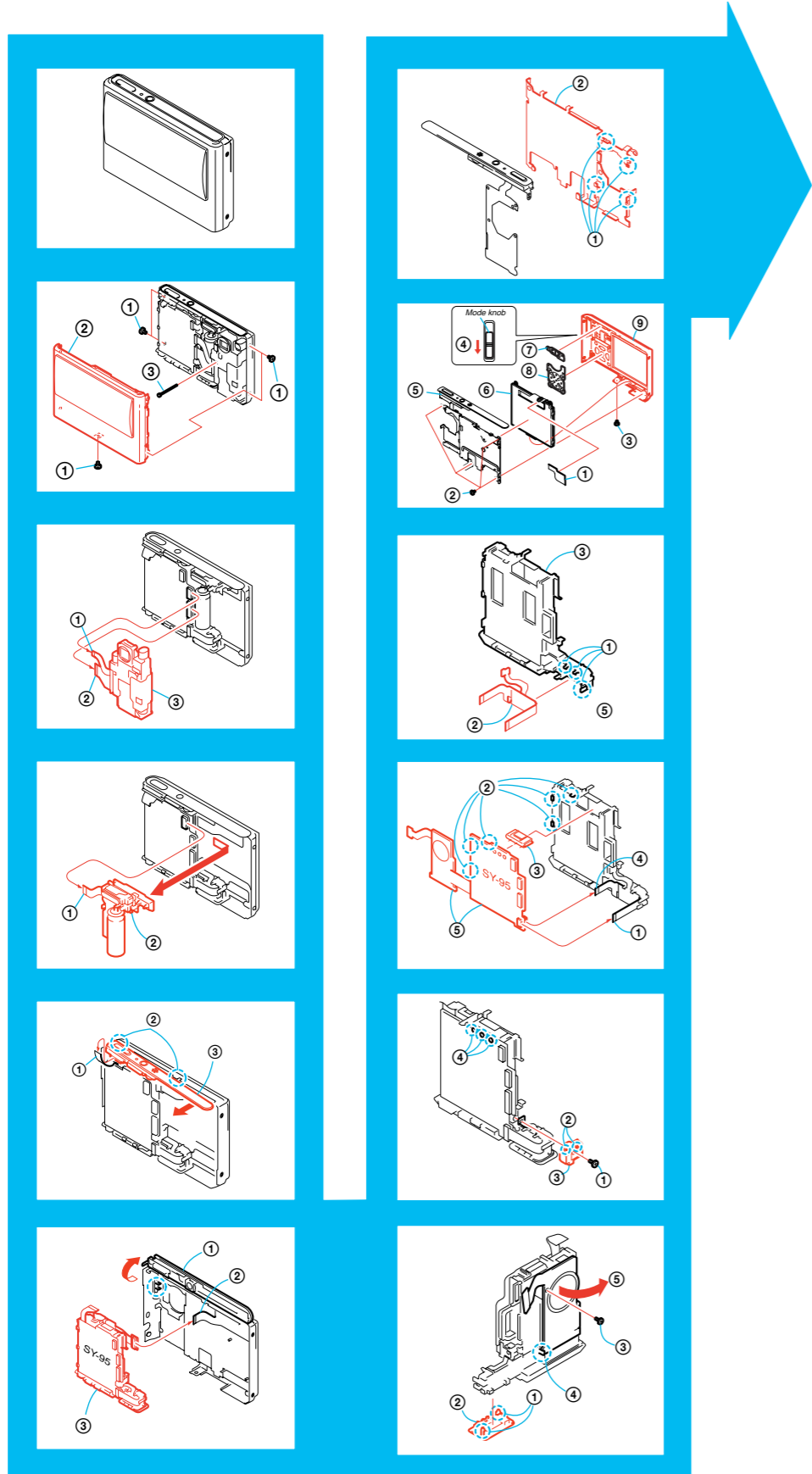

[SERVICE POSITION TO CHECK THE SY-95 BOARD]

Note1: By using an adhesive tape, press the LENS COVER switch (S401).

Note2: When checking the VIDEO AMP (SY-95 board IC302) or the USB circuit, connect the cradle.

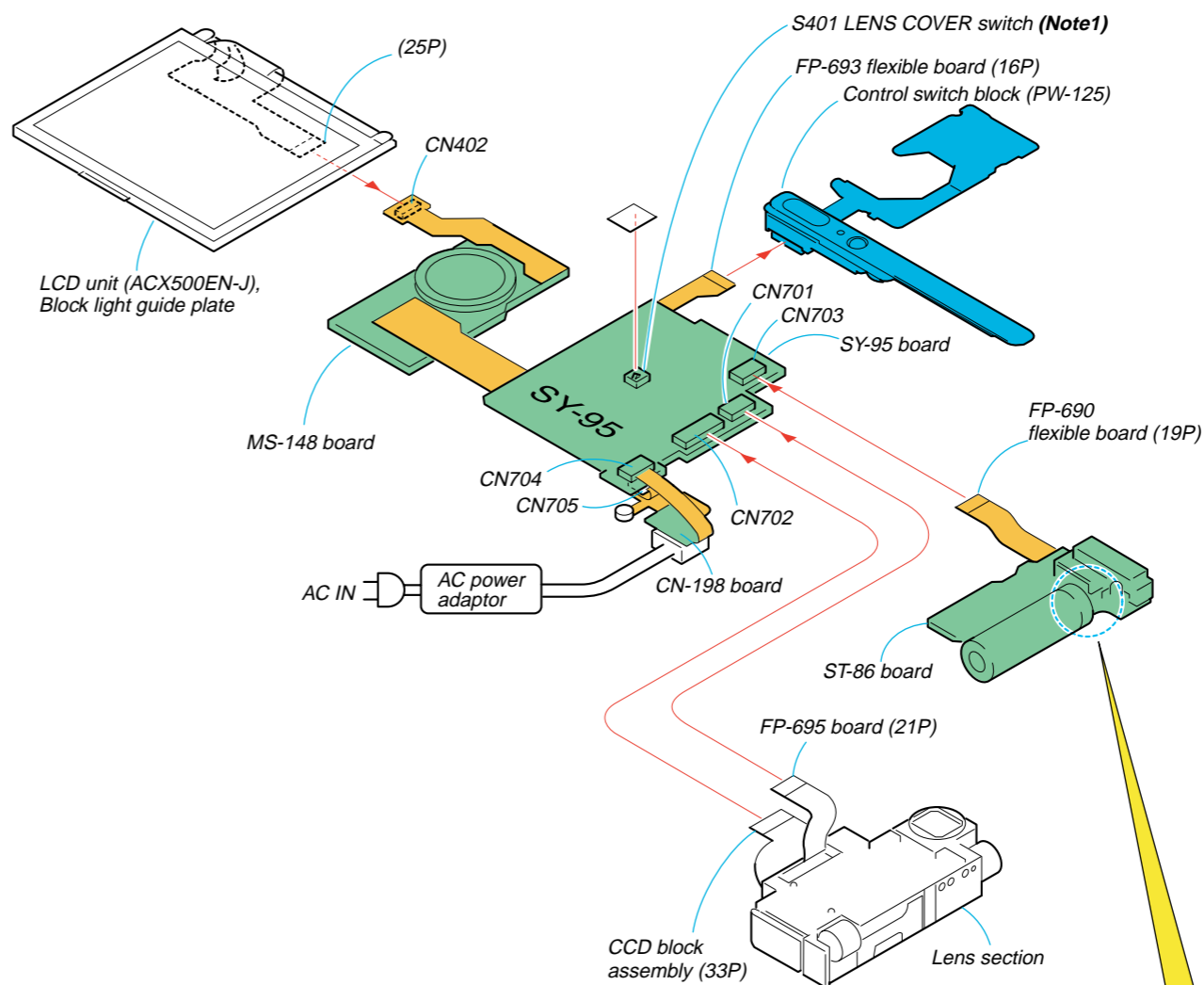

Note : The power capacitor of the flash unit is charged up to 315 V maximum. If you touch the capacitor terminal that is charged to high voltage, you will receive an electric shock. This high voltage is not discharged even if you turned off the main power of this set, and it residues. Discharge the residual voltage referring to the service note (page 1-1).

2. DISASSEMBLY

2-3. CIRCUIT BOARDS LOCATION

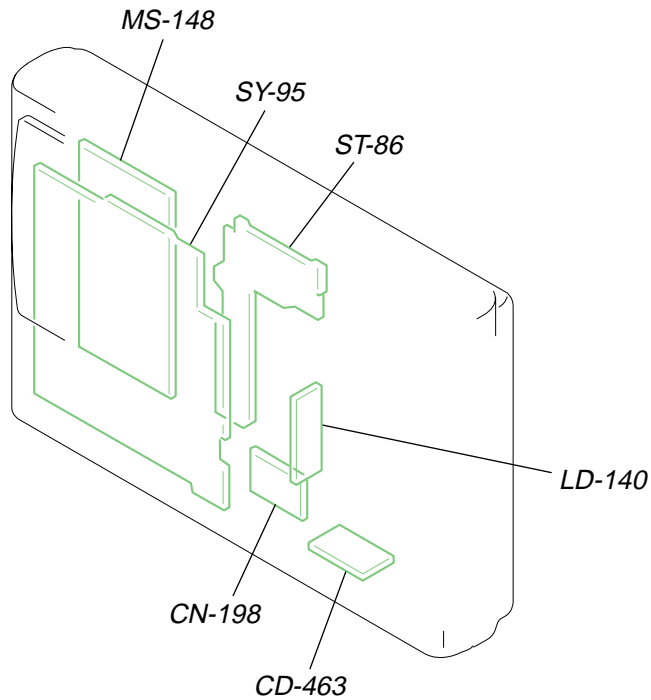

NAME	FUNCTION
CD-463	CCD IMAGER
CN-198	MULTI CONNECTOR
LD-140	LENS DRIVE
MS-148	MS I/O, LCD PANEL DRIVE
ST-86	FLASH
SY-95	CAMERA A/D CONVERTER, TIMING GENERATOR, CAMERA DSP, LENS CONTROL, CAMERA SYSTEM CONTROL, HI CONTROL, AUDIO I/O, FLASH DRIVE, DC/DC CONVERTER, CONNECTOR

2-4. FLEXIBLE BOARDS LOCATION

The flexible boards contained in the lens block are not shown.

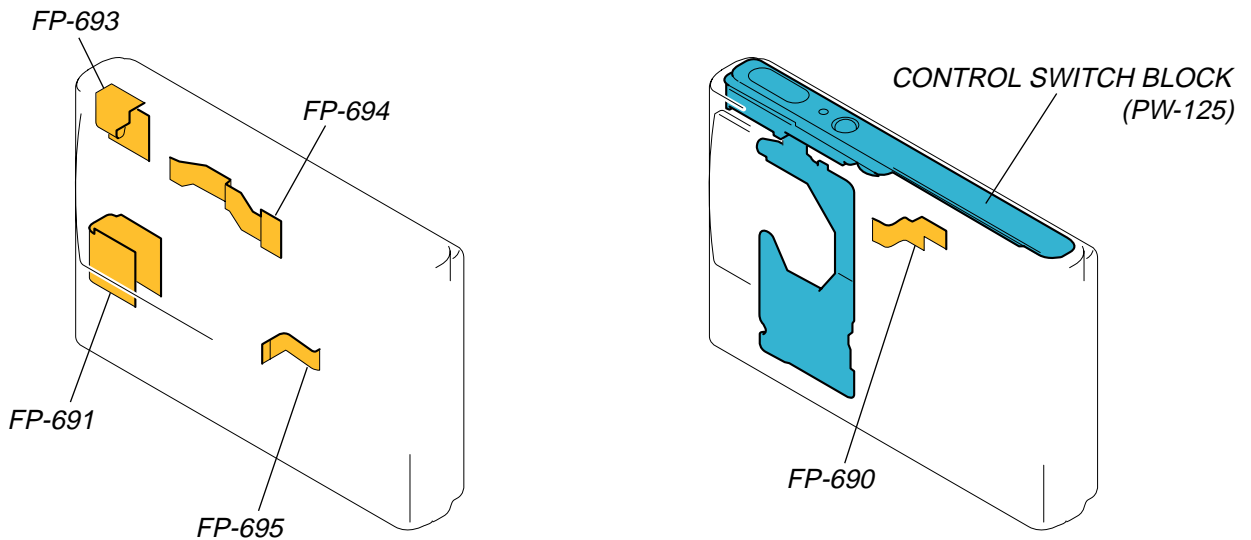

HELP

Sheet attachment positions and procedures of processing the flexible boards/harnesses are shown.

HELP 01

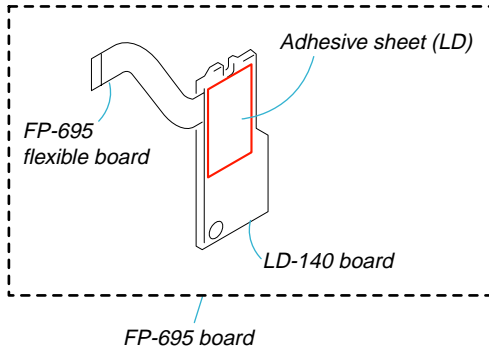

HELP 02

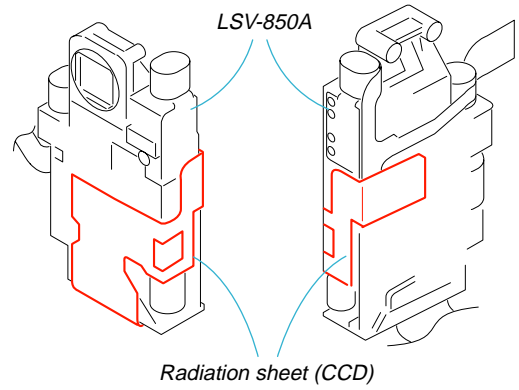

HELP 03

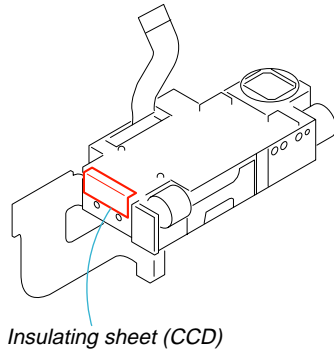

HELP 04

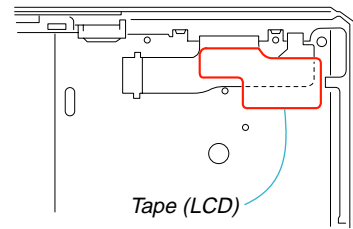

HELP 05

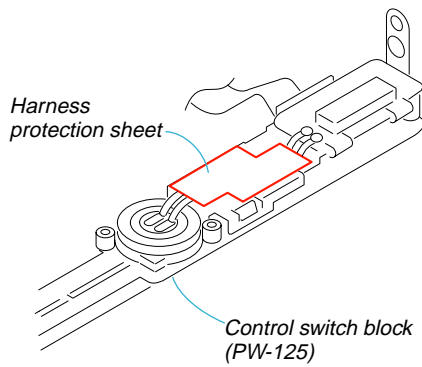

HELP 06

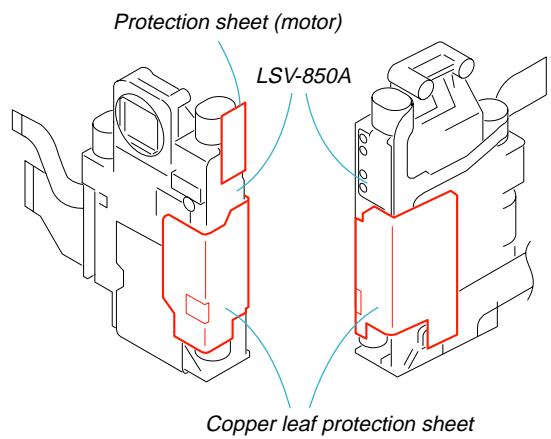

HELP 07

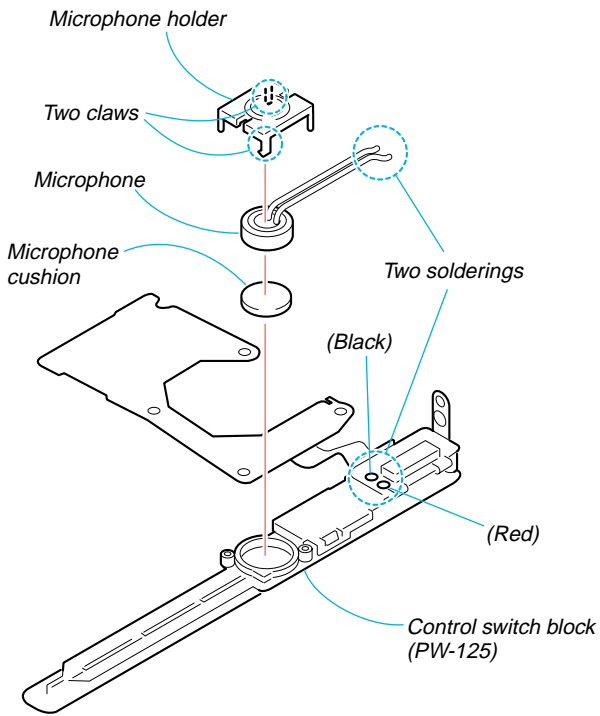

HELP 09

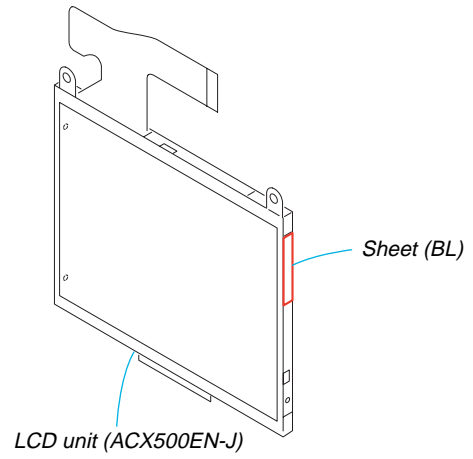

HELP 10

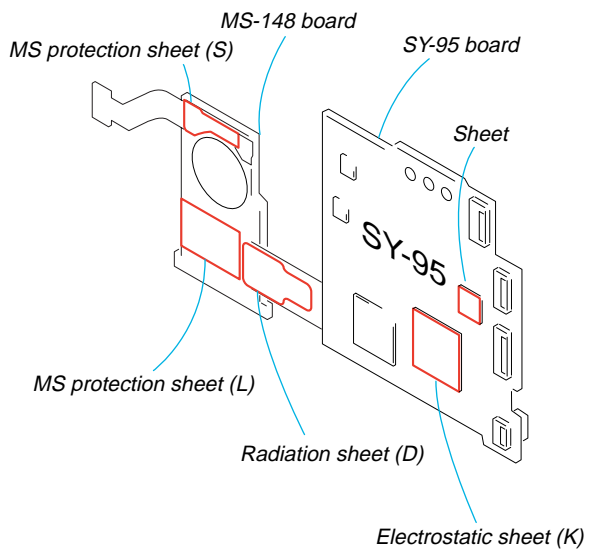

HELP 11

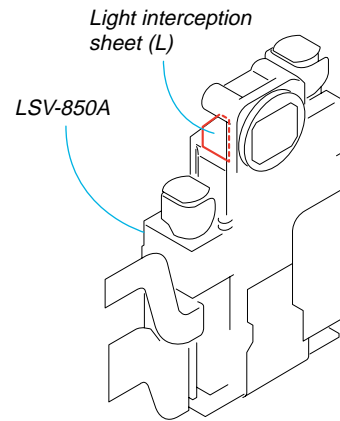

HELP 08
(disassembly of the Battery holder section)

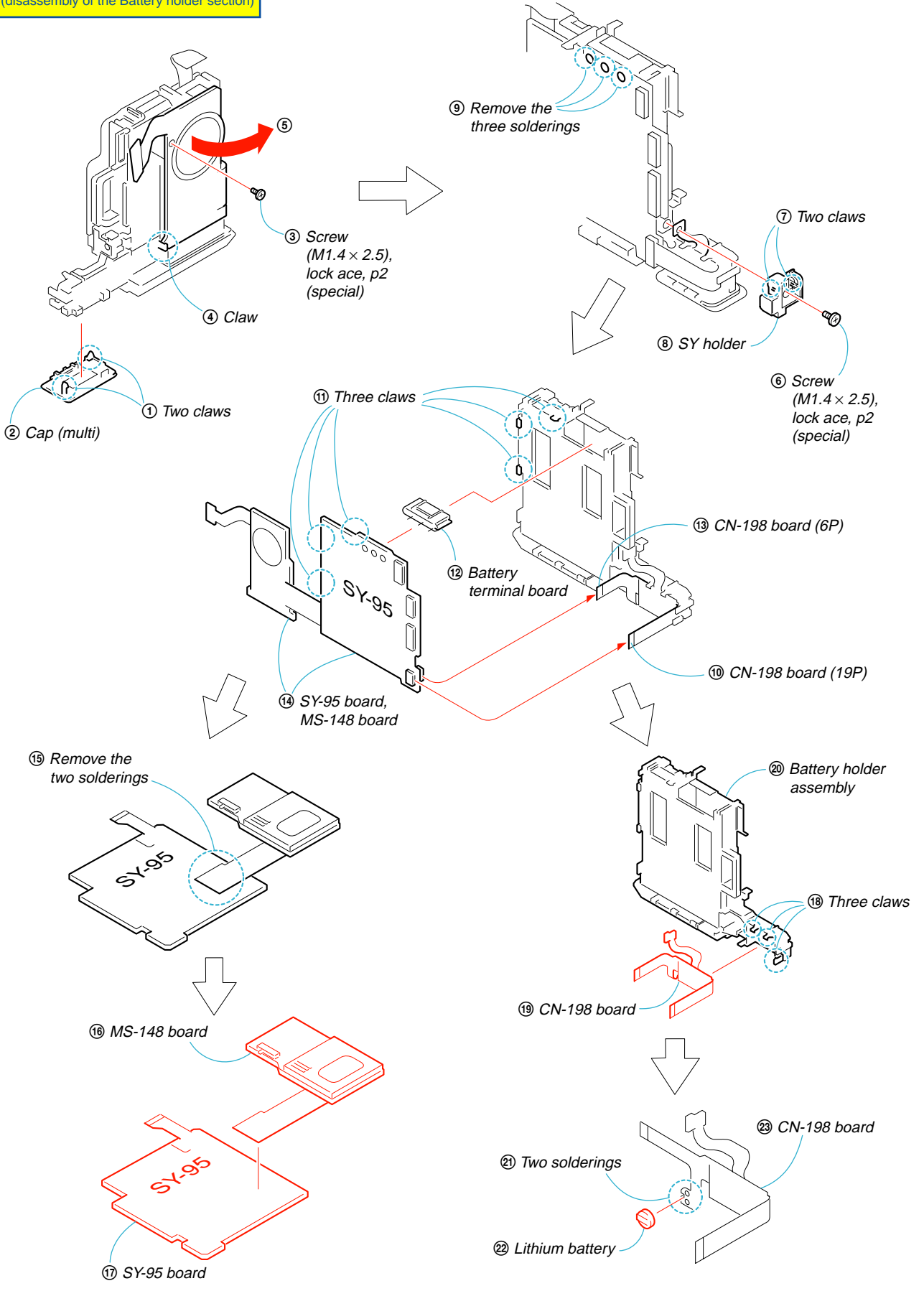

3. BLOCK DIAGRAMS

Link

• [OVERALL BLOCK DIAGRAM \(1/2\)](#)

• [POWER BLOCK DIAGRAM \(1/2\)](#)

• [OVERALL BLOCK DIAGRAM \(2/2\)](#)

• [POWER BLOCK DIAGRAM \(2/2\)](#)

SECTION 3 BLOCK DIAGRAMS

3. BLOCK DIAGRAMS

3-1. OVERALL BLOCK DIAGRAM (1/2) () : Number in parenthesis () indicates the division number of schematic diagram where the component is located.

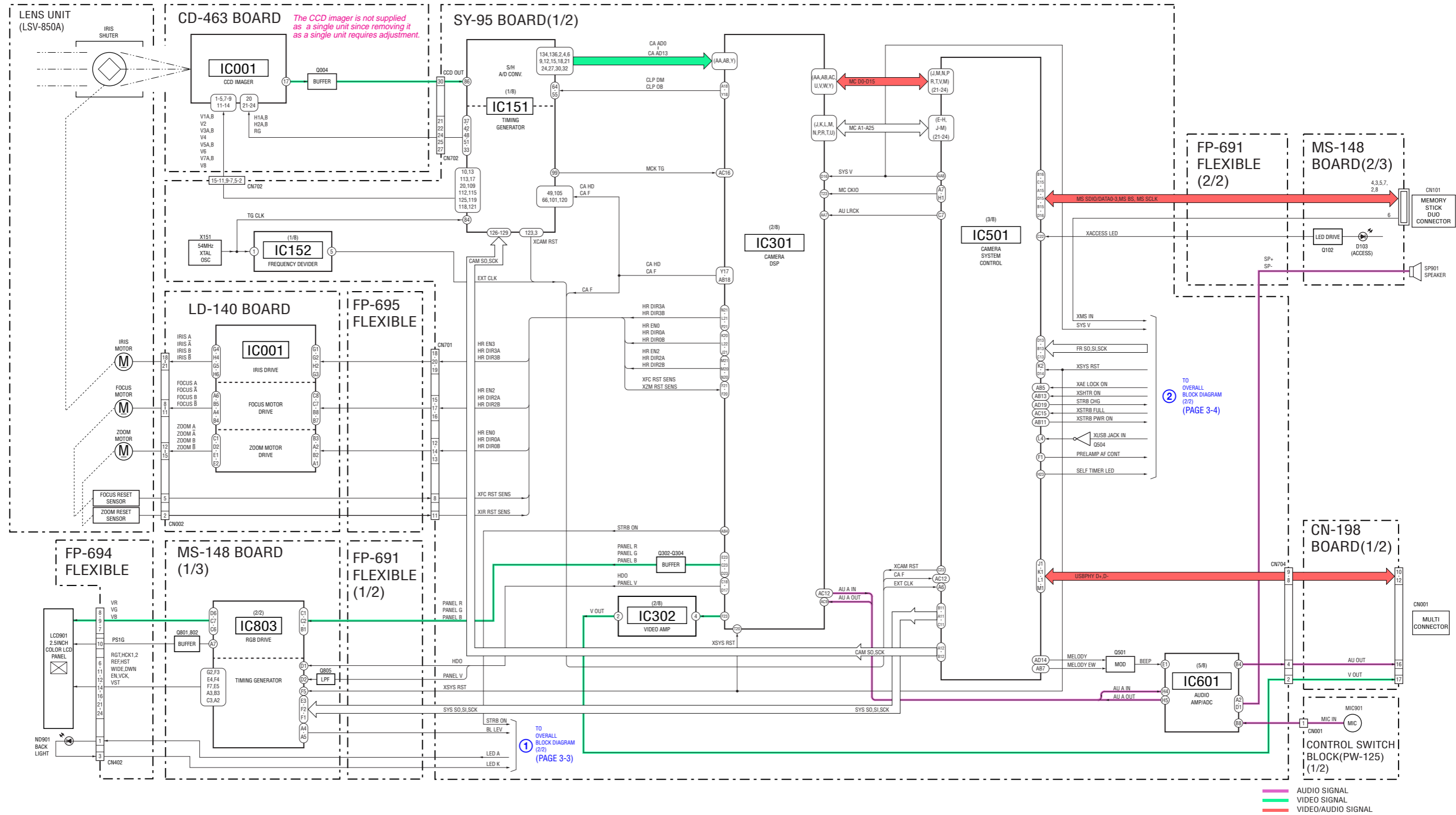

3. BLOCK DIAGRAMS

3-2. OVERALL BLOCK DIAGRAM (2/2) () : Number in parenthesis () indicates the division number of schematic diagram where the component is located.

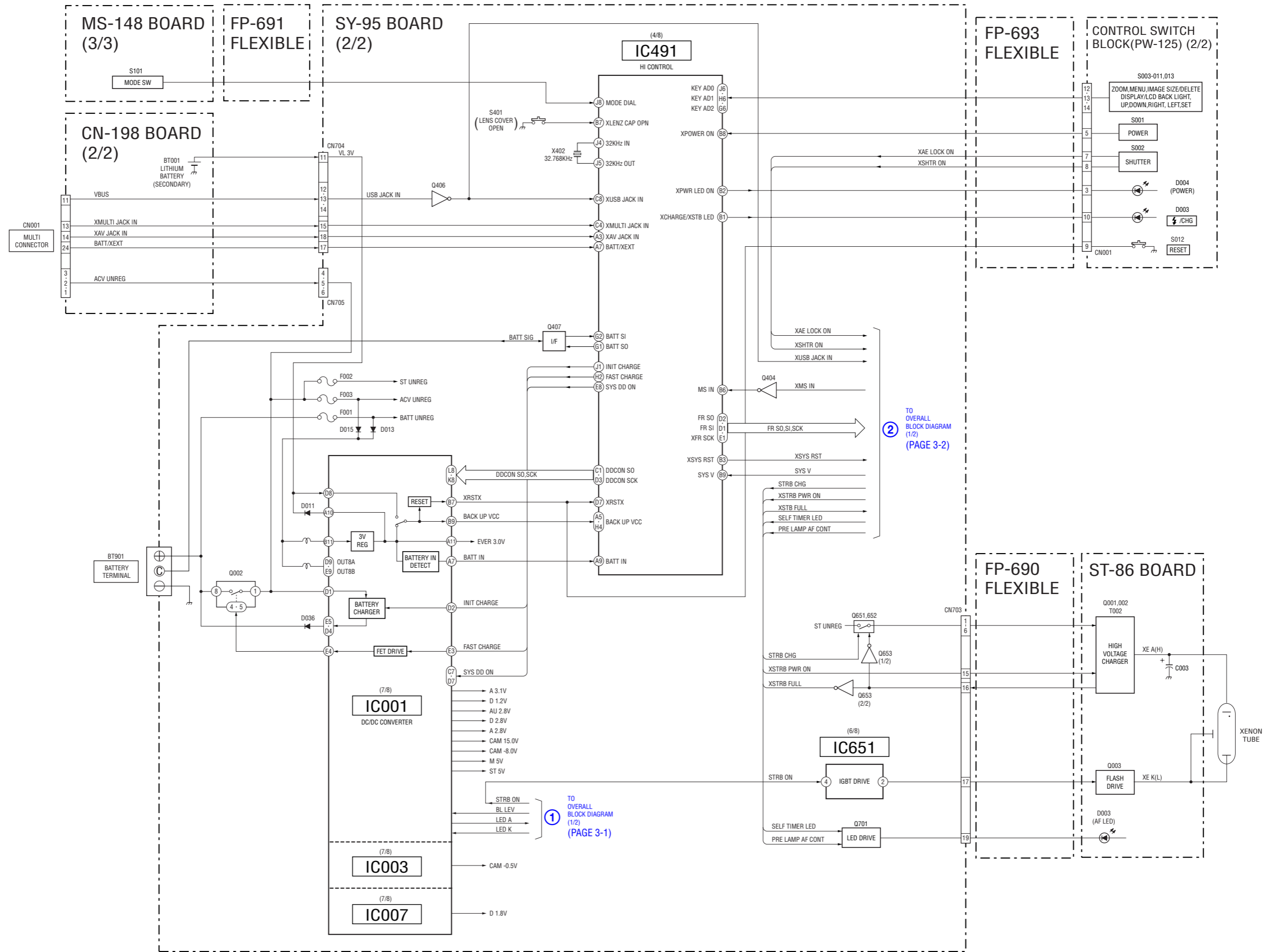

3. BLOCK DIAGRAMS

3-3. POWER BLOCK DIAGRAM (1/2) () : Number in parenthesis () indicates the division number of schematic diagram where the component is located.

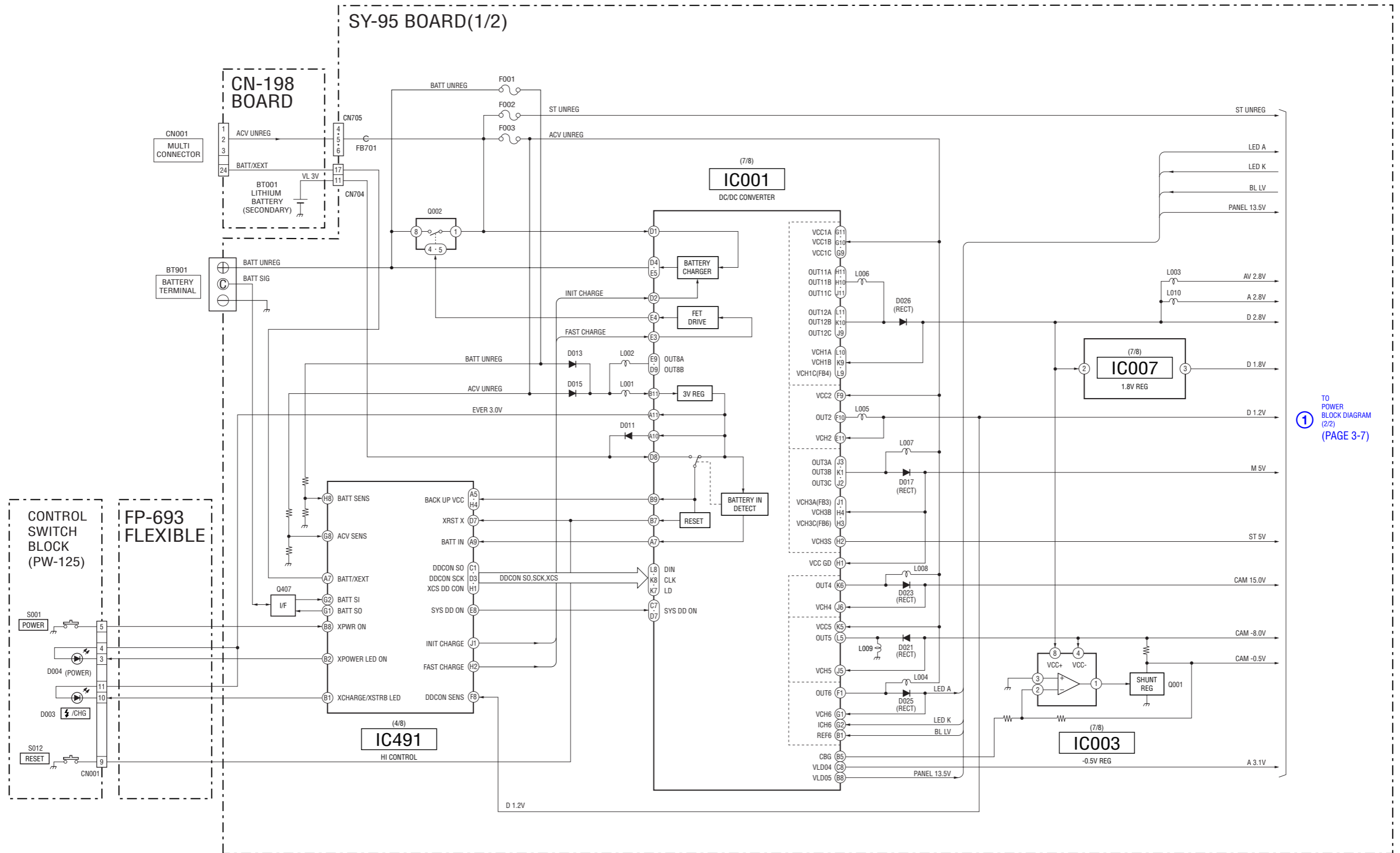

TO POWER BLOCK DIAGRAM (2/2) (PAGE 3-7)

3. BLOCK DIAGRAMS

3-4. POWER BLOCK DIAGRAM (2/2) () : Number in parenthesis () indicates the division number of schematic diagram where the component is located.

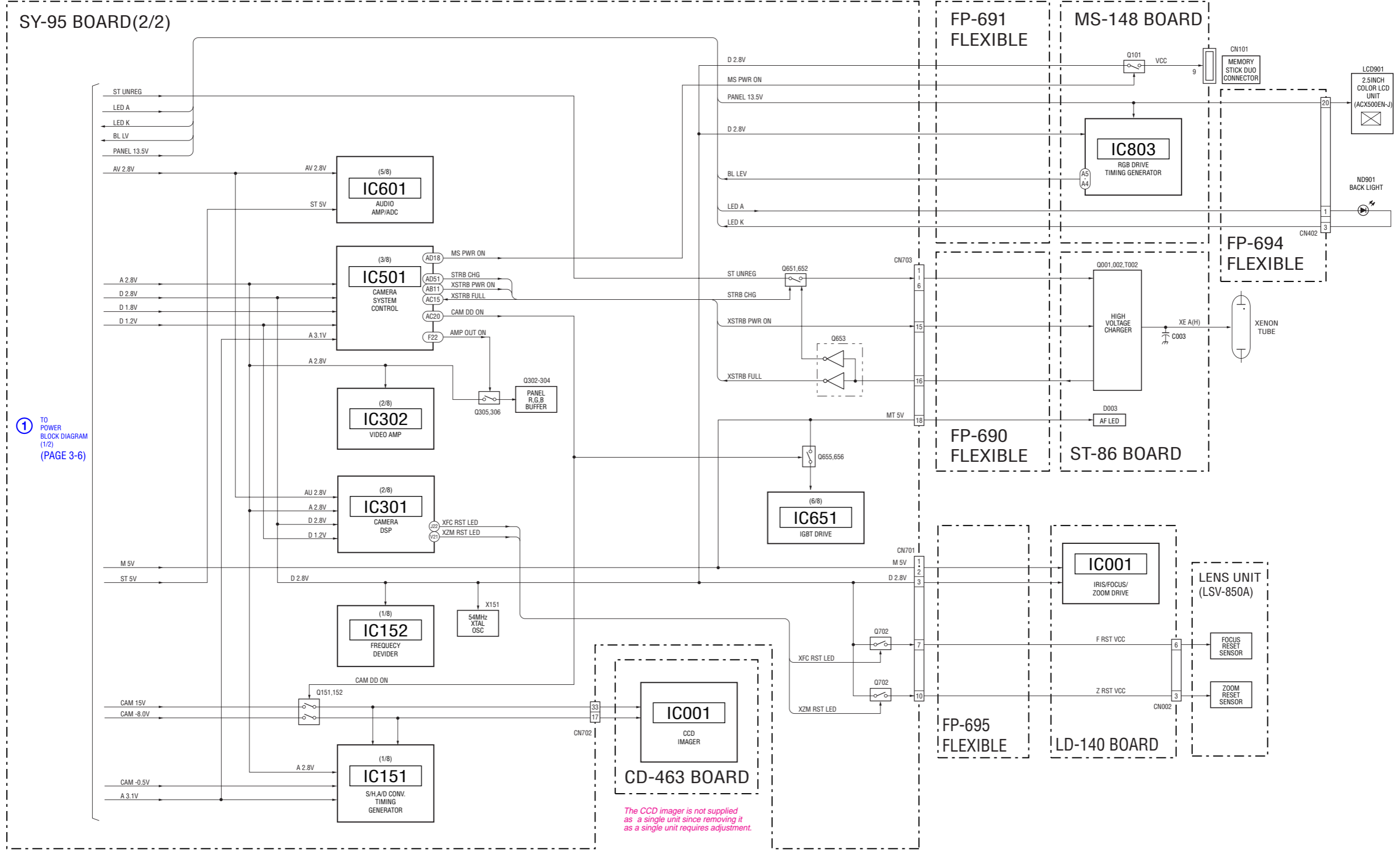

① TO POWER BLOCK DIAGRAM (1/2) (PAGE 3-6)

The CCD imager is not supplied as a single unit since removing it as a single unit requires adjustment.

SECTION 4
PRINTED WIRING BOARDS AND SCHEMATIC DIAGRAMS

4-1. FRAME SCHEMATIC DIAGRAM (1/2)

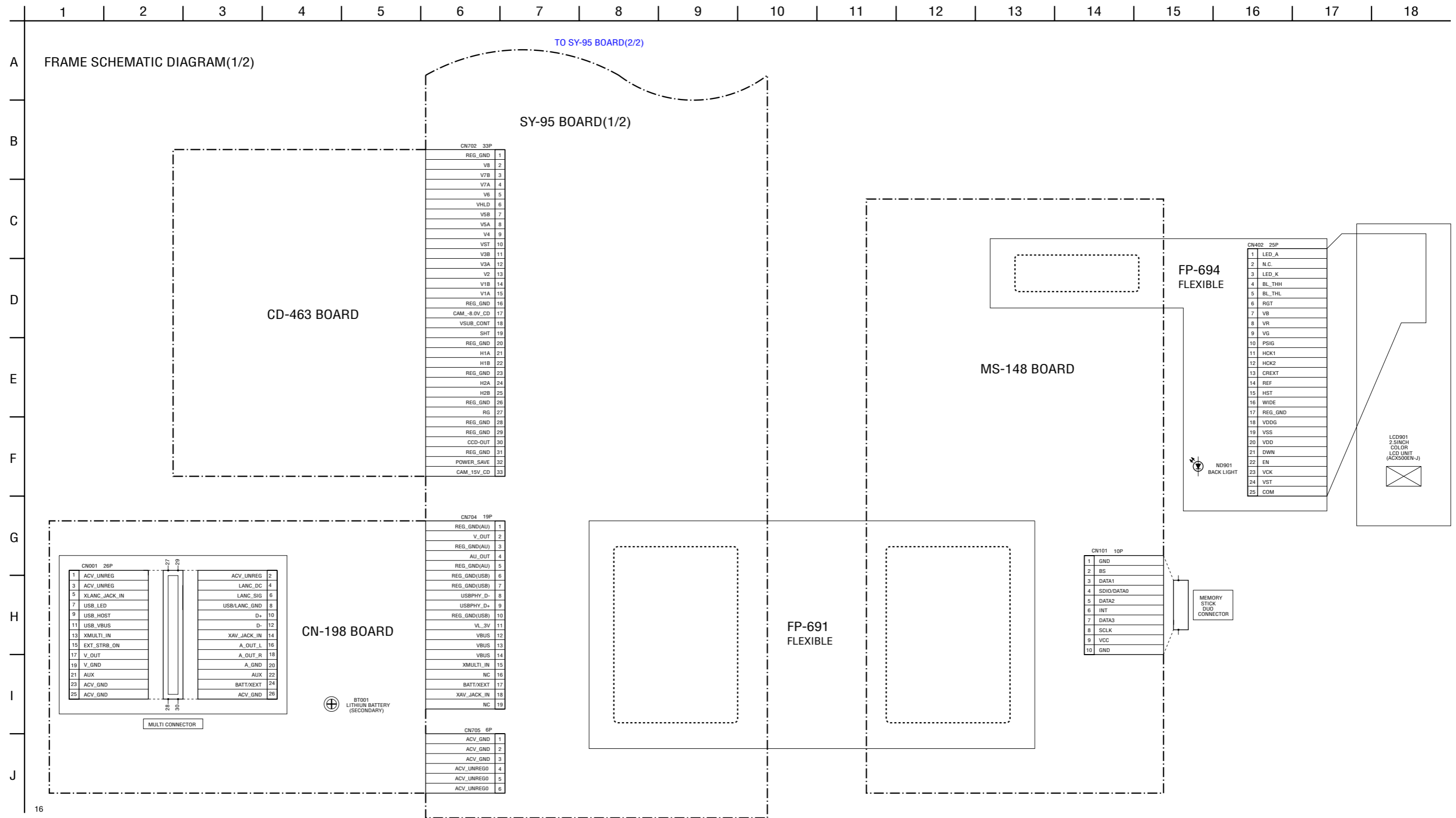

4-2. SCHEMATIC DIAGRAMS

4-3. PRINTED WIRING BOARDS

FRAME SCHEMATIC DIAGRAM (2/2)

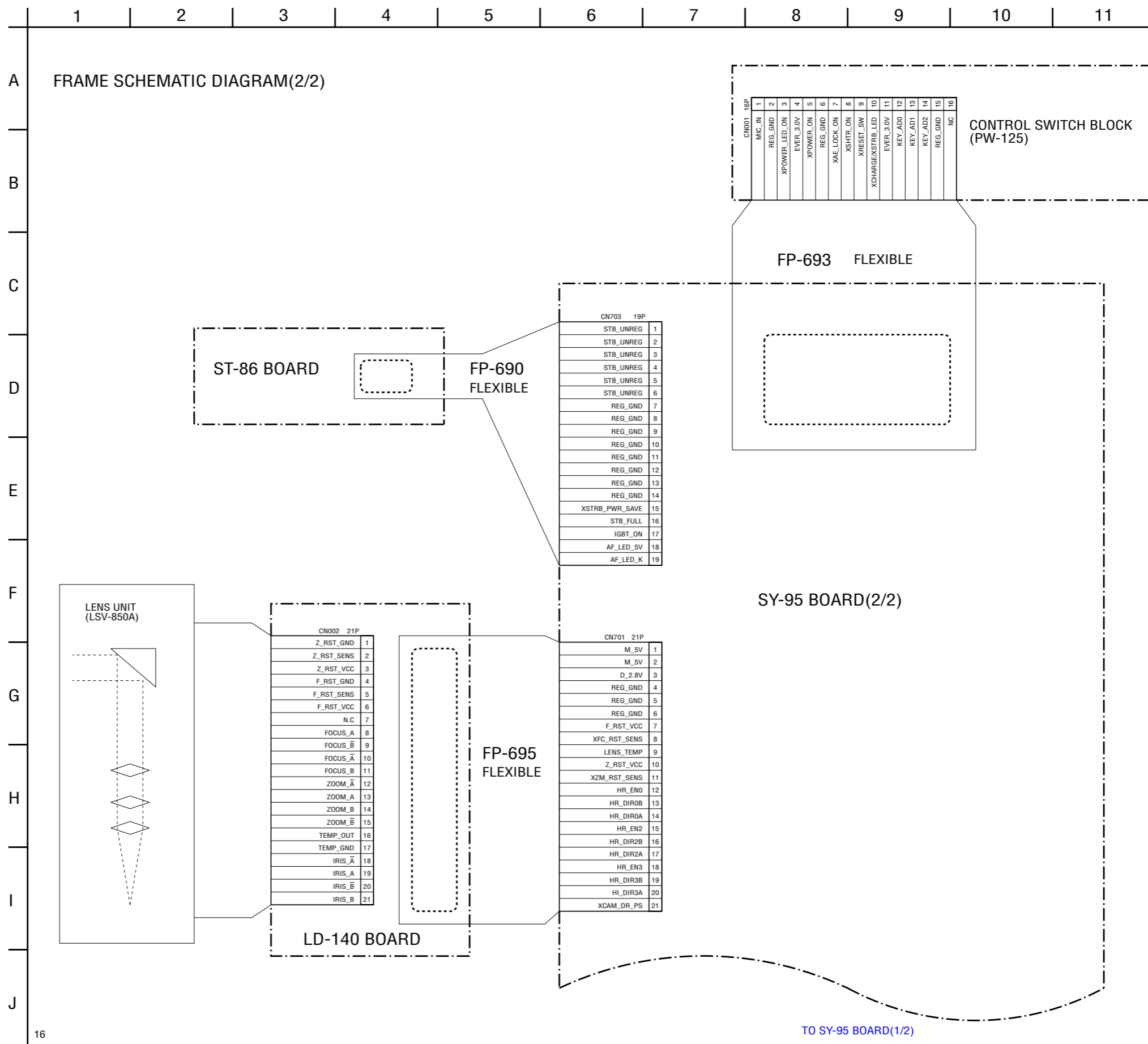

4-2. SCHEMATIC DIAGRAMS

Link

<ul style="list-style-type: none">• CD-463 BOARD (CCD IMAGER)	<ul style="list-style-type: none">• ST-86 BOARD (FLASH)
<ul style="list-style-type: none">• CN-198 BOARD (MULTI CONNECTOR)	<ul style="list-style-type: none">• CONTROL SWITCH BLOCK (PW-125)
<ul style="list-style-type: none">• COMMON NOTE FOR SCHEMATIC DIAGRAMS	

4-2. SCHEMATIC DIAGRAMS

THIS NOTE IS COMMON FOR SCHEMATIC DIAGRAMS
 (In addition to this, the necessary note is printed in each block)

(For schematic diagrams)

- All capacitors are in μF unless otherwise noted. $\text{pF} : \mu\text{F} : \mu\text{F}$. 50 V or less are not indicated except for electrolytics and tantalums.
- Chip resistors are 1/10 W unless otherwise noted. $\text{k}\Omega=1000 \Omega$, $\text{M}\Omega=1000 \text{k}\Omega$.
- Caution when replacing chip parts.
 New parts must be attached after removal of chip.
 Be careful not to heat the minus side of tantalum capacitor, Because it is damaged by the heat.
- Some chip part will be indicated as follows.

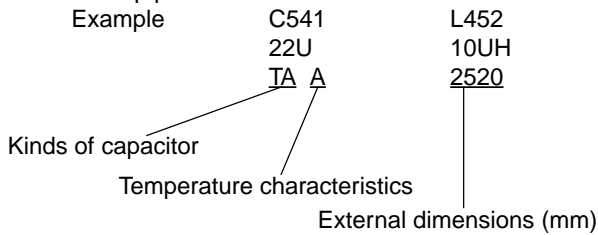

- Constants of resistors, capacitors, ICs and etc with XX indicate that they are not used.
 In such cases, the unused circuits may be indicated.
- Parts with * differ according to the model/destination.
 Refer to the mount table for each function.
- All variable and adjustable resistors have characteristic curve B, unless otherwise noted.
- Signal name
 XEDIT → EDIT PB/XREC → PB/REC
- : non flammable resistor
- : fusible resistor
- : panel designation
- : B+ Line
- : B- Line
- : IN/OUT direction of (+,-) B LINE.
- : adjustment for repair.
- : VIDEO SIGNAL (ANALOG)
- : AUDIO SIGNAL (ANALOG)
- : VIDEO/AUDIO SIGNAL (ANALOG)
- : VIDEO/AUDIO/SERVO SIGNAL
- : SERVO SIGNAL
- Circled numbers refer to waveforms.

(Measuring conditions voltage and waveform)

- Voltages and waveforms are measured between the measurement points and ground when camera shoots color bar chart of pattern box. They are reference values and reference waveforms.
 (VOM of DC 10 M Ω input impedance is used)
- Voltage values change depending upon input impedance of VOM used.)

Precautions Upon Replacing CCD imager

- The CD-463 board mounted as a repair part is not equipped with a CCD imager.
 When replacing this board, remove the CCD imager from the old one and mount it onto the new one.
- If the CCD imager has been replaced, carry out all the adjustments for the camera section.
- As the CCD imager may be damaged by static electricity from its structure, handle it carefully like for the MOS IC.
 In addition, ensure that the receiver is not covered with dusts nor exposed to strong light.

1. Connection

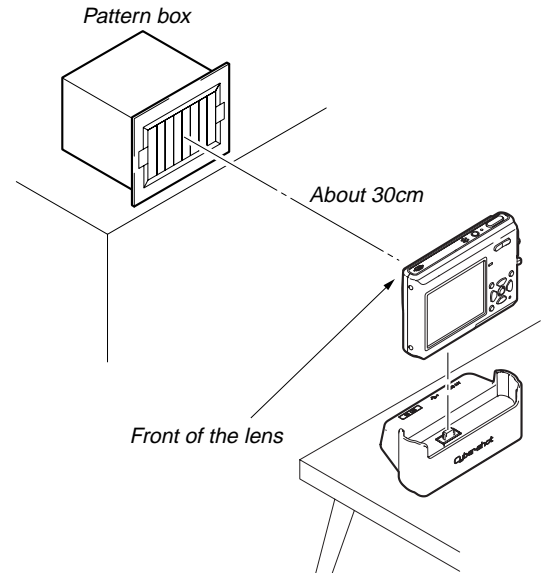

2. Adjust the distance so that the output waveform of Fig. a and the Fig. b can be obtain.

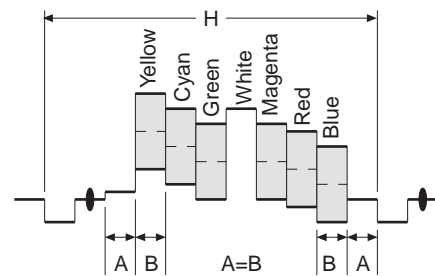

Fig. a (Video output terminal output waveform)

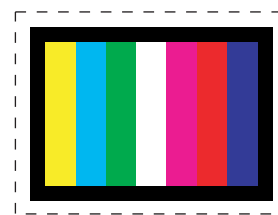

Fig.b (Picture on monitor TV)

When indicating parts by reference number, please include the board name.

Note :
 The components identified by mark Δ or dotted line with mark Δ are critical for safety.
 Replace only with part number specified.

Note :
 Les composants identifiés par une marque Δ sont critiques pour la sécurité.
 Ne les remplacer que par une pièce portant le numéro spécifié.

4-2. SCHEMATIC DIAGRAMS CD-463 PRINTED WIRING BOARD

4-2. SCHEMATIC DIAGRAMS For Schematic Diagram
 • Refer to page 4-41 for printed wiring board.

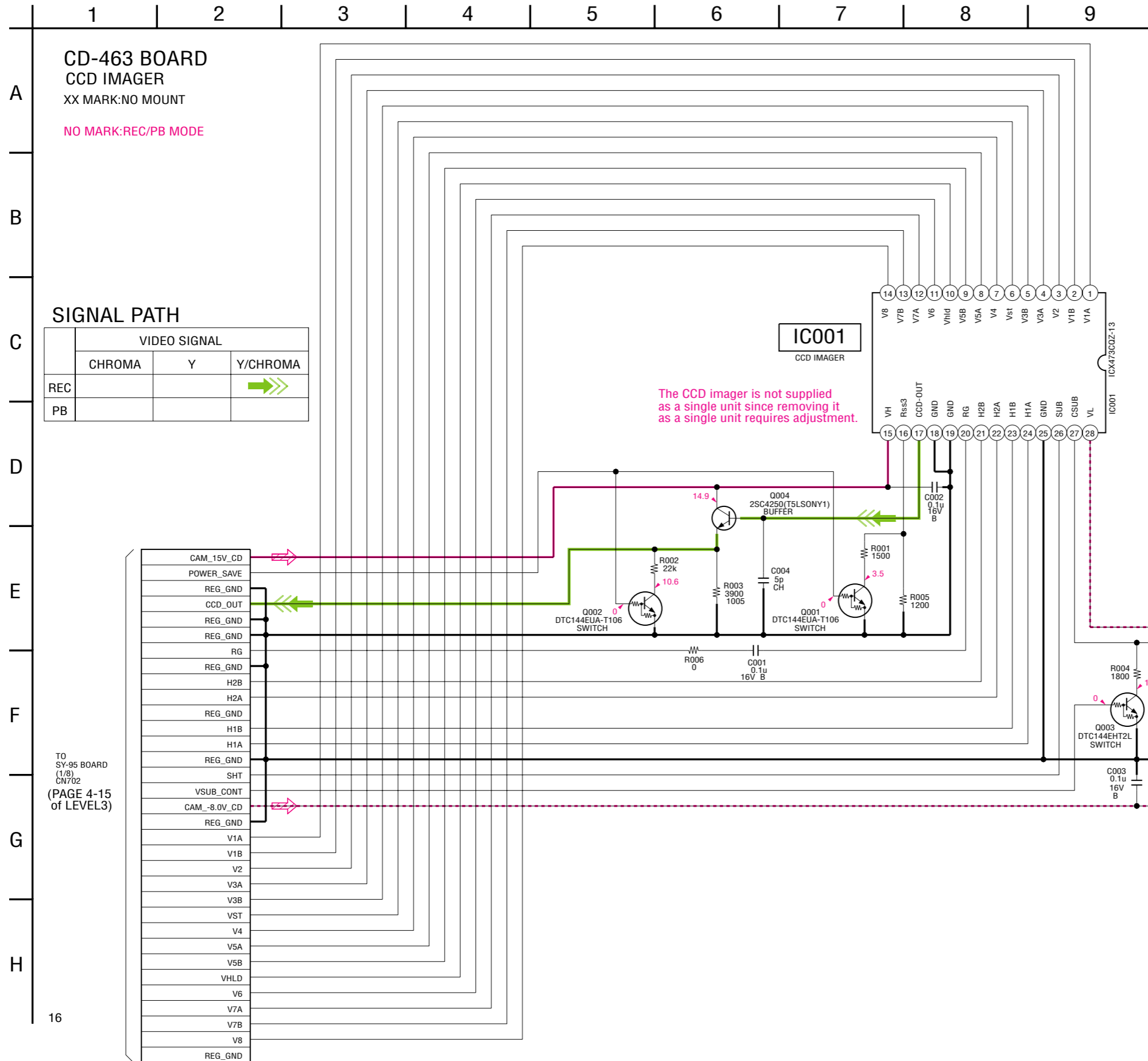

4-2. SCHEMATIC DIAGRAMS CN-198 PRINTED WIRING BOARD

For Schematic Diagram
 • Refer to page 4-43 for printed wiring board.

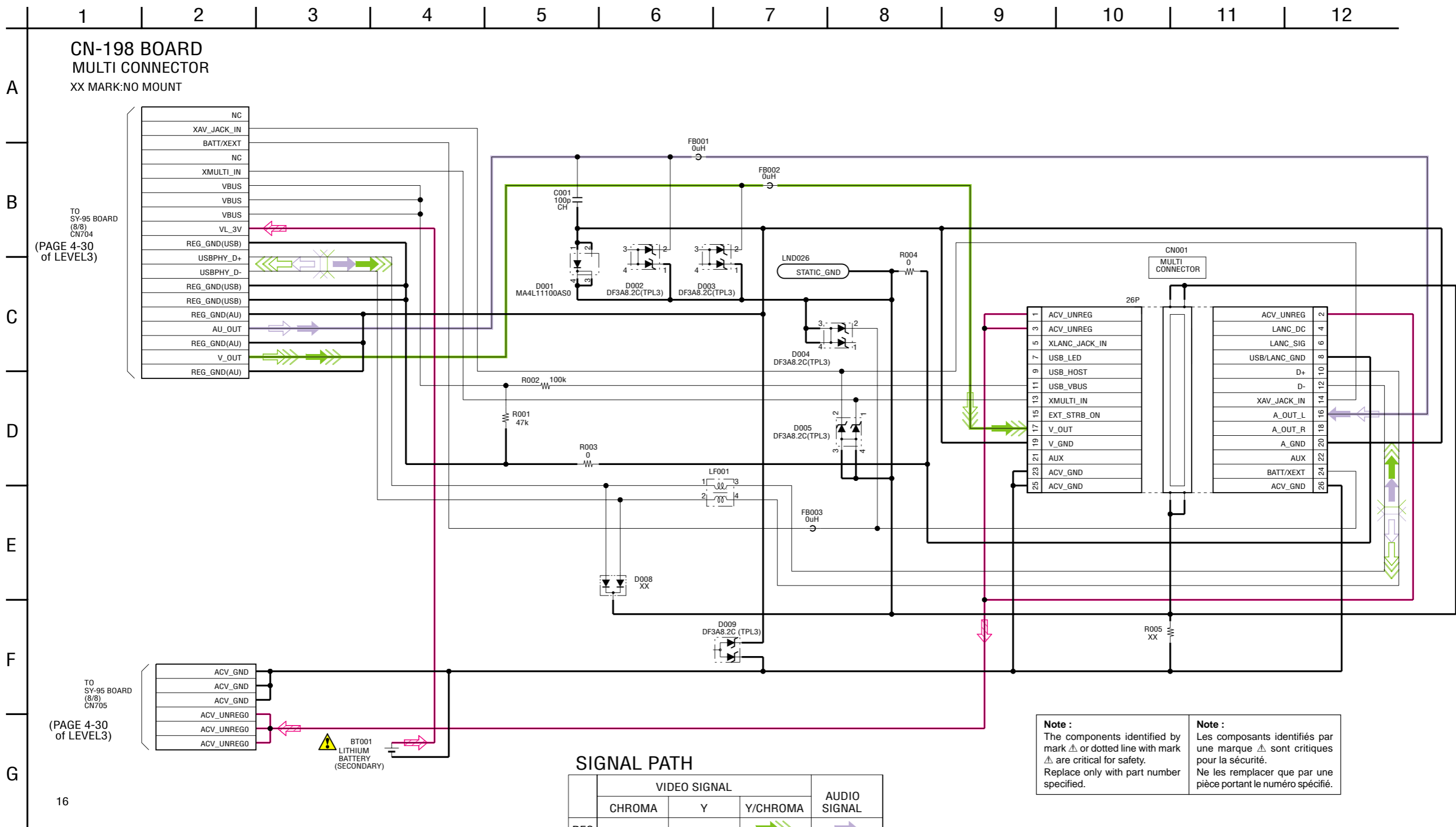

4-2. SCHEMATIC DIAGRAMS ST-86 PRINTED WIRING BOARD

For Schematic Diagram
 • Refer to page 4-42 for printed wiring board.

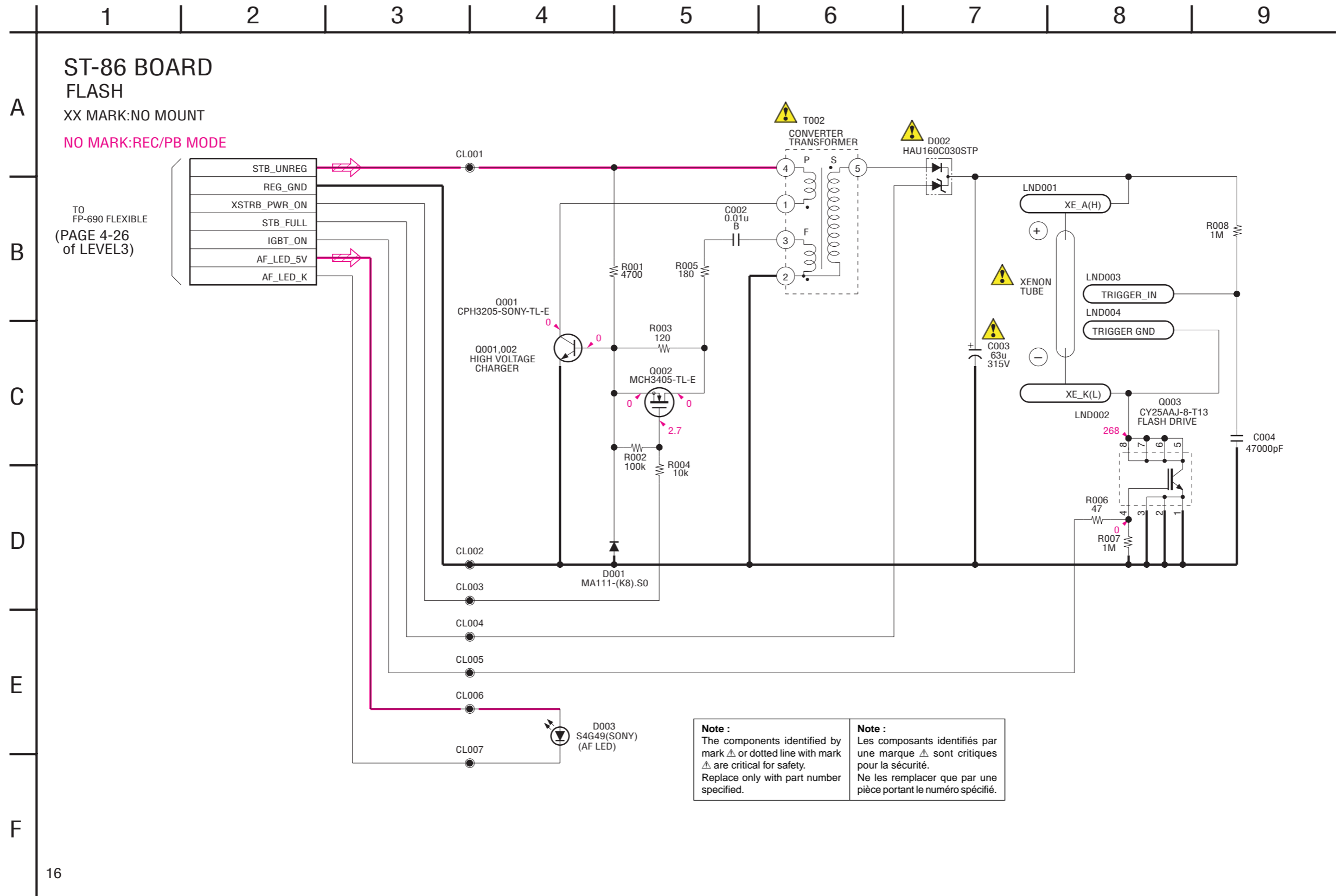

1 | 2 | 3 | 4 | 5 | 6 | 7 | 8 | 9

CONTROL SWITCH BLOCK(PW-125)

A
B
C
D
E
F

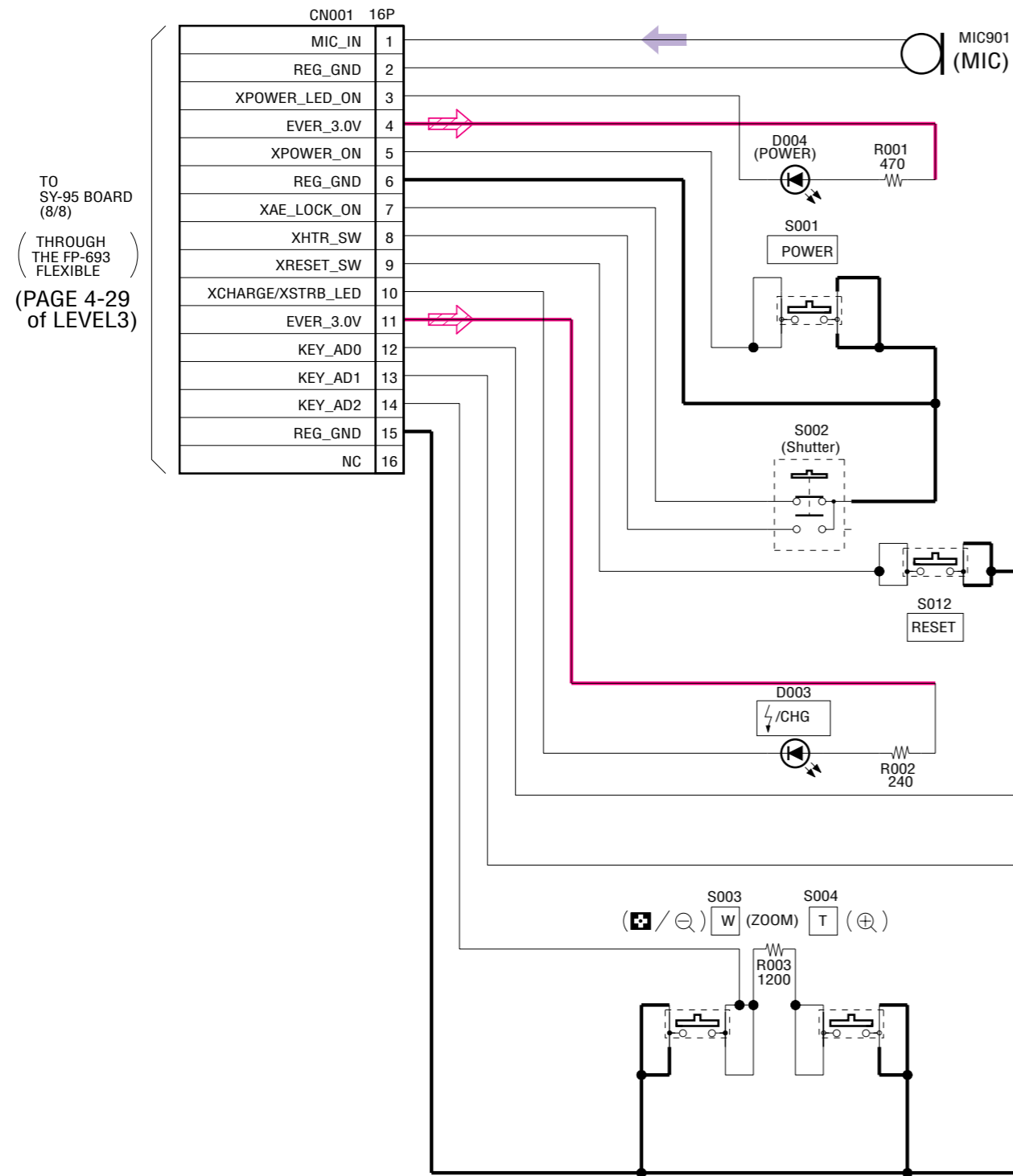

TO
SY-95 BOARD
(8/8)
(THROUGH
THE FP-693
FLEXIBLE
(PAGE 4-29
of LEVEL3))

SIGNAL PATH

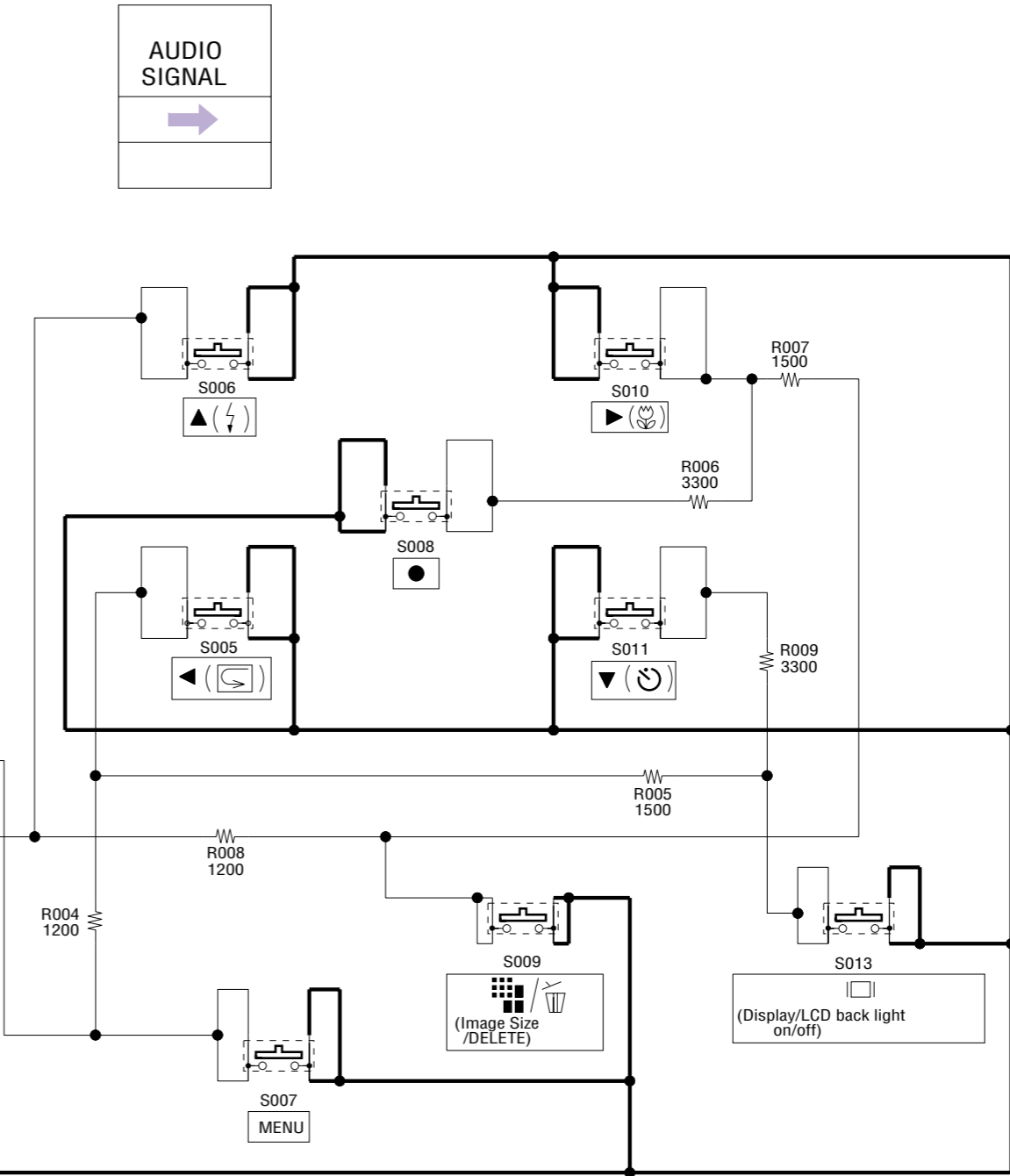

16

Schematic diagram of the LD-140, MS-148 and SY-95 boards are not shown. Pages from 4-15 to 4-36 are not shown.

4-3. PRINTED WIRING BOARDS

Link

• [CD-463 BOARD](#)

• [CN-198 BOARD](#)

• [ST-86 BOARD](#)

• [COMMON NOTE FOR PRINTED WIRING BOARDS](#)

• [MOUNTED PARTS LOCATION](#)

• [CIRCUIT BOARDS LOCATION](#)



• [FLEXIBLE BOARDS LOCATION](#)

NAME	FUNCTION
<i>CD-463</i>	<i>CCD IMAGER</i>
<i>CN-198</i>	<i>MULTI CONNECTOR</i>
<i>LD-140</i>	<i>LENS DRIVE</i>
<i>MS-148</i>	<i>MS I/O, LCD PANEL DRIVE</i>
<i>ST-86</i>	<i>FLASH</i>
<i>SY-95</i>	<i>CAMERA A/D CONVERTER, TIMING GENERATOR, CAMERA DSP, LENS CONTROL, CAMERA SYSTEM CONTROL, HI CONTROL, AUDIO I/O, FLASH DRIVE, DC/DC CONVERTER, CONNECTOR</i>

4-3. PRINTED WIRING BOARDS

THIS NOTE IS COMMON FOR WIRING BOARDS
(In addition to this, the necessary note is printed in each block)

(For printed wiring boards)

-  : Uses unleaded solder.
-  : Pattern from the side which enables seeing.
 (The other layers' patterns are not indicated)
- Through hole is omitted.
- Circled numbers refer to waveforms.
- There are a few cases that the part printed on diagram isn't mounted in this model.
-  : panel designation

• Chip parts.

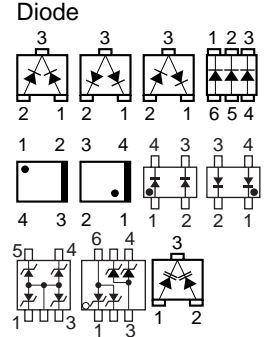
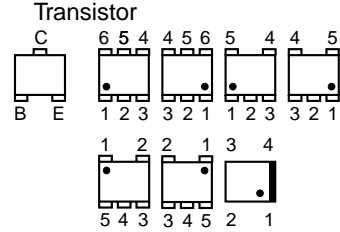

BOARD INFORMATION

board name	parts location (shown on page)	pattern		CSP IC
		number of layers	layers not shown	
CD-463	4-53	2	—	—
ST-86	4-53	4	2 and 3	—
CN-198	4-53	4	—	—
FP-694	—	2	—	—
LD-140	4-54	4	2 and 3	IC001
FP-695	—	1	—	—
MS-148	4-55	6	2 to 5	IC803
SY-95	4-54	8	2 to 7	IC001, IC151, IC301, IC491, IC501, IC601

4-2. SCHEMATIC DIAGRAMS

4-3. PRINTED WIRING BOARDS

MOUNTED PARTS LOCATION

4-3. PRINTED WIRING BOARDS

• Refer to page 4-39 for common note for printed wiring board. •  : Uses unleaded solder.

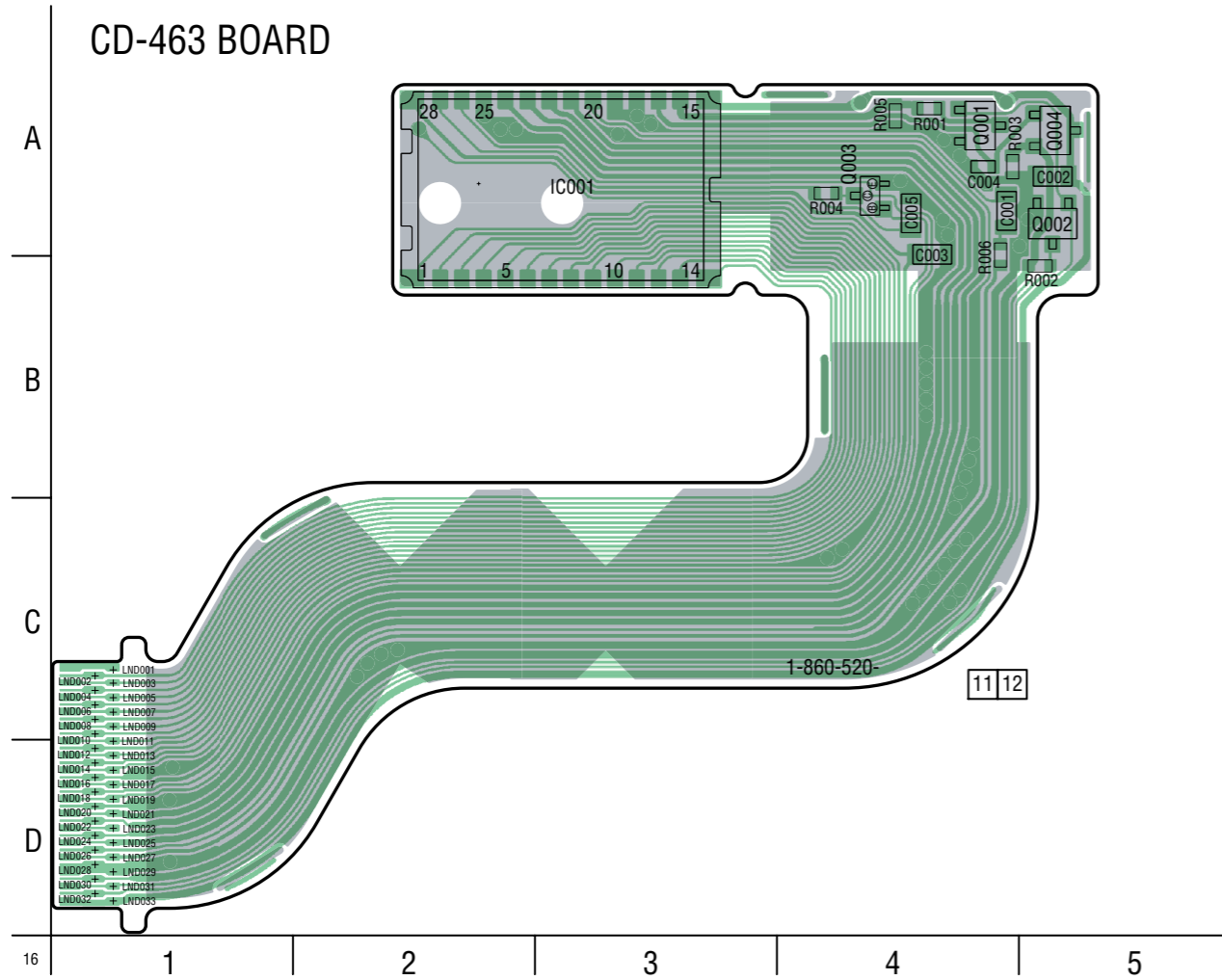

The CCD imager is not supplied as a single unit since removing it as a single unit requires adjustment.

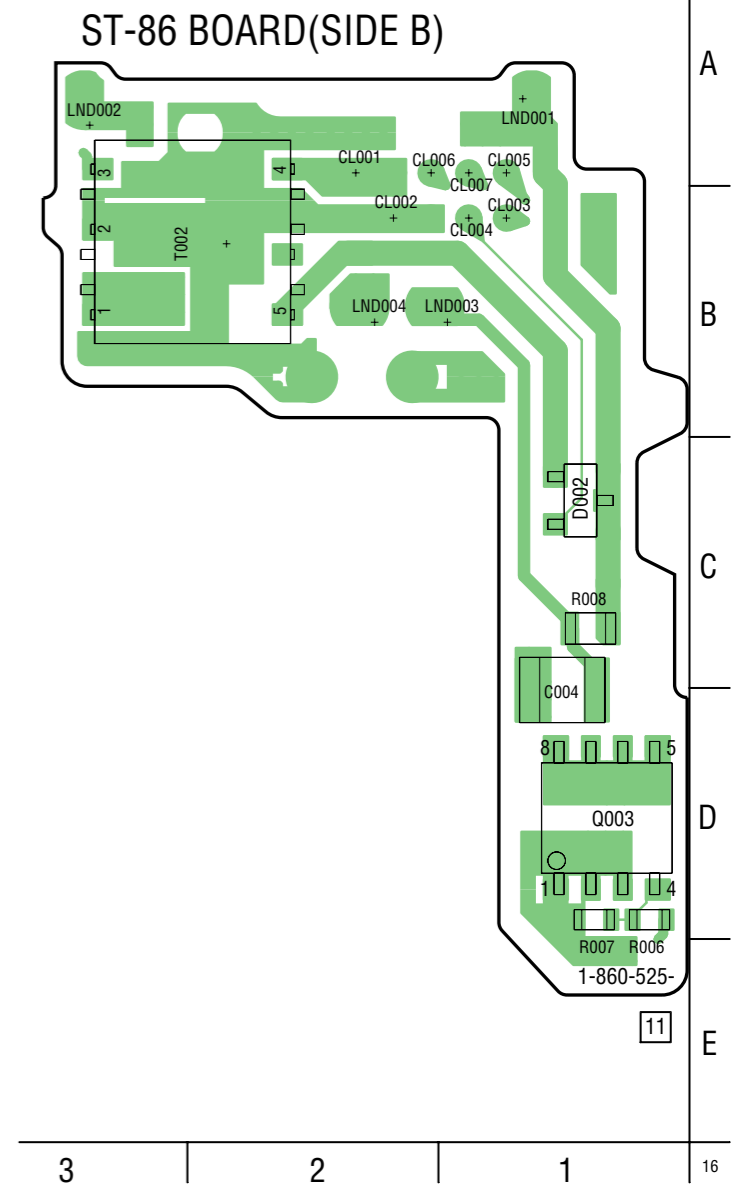
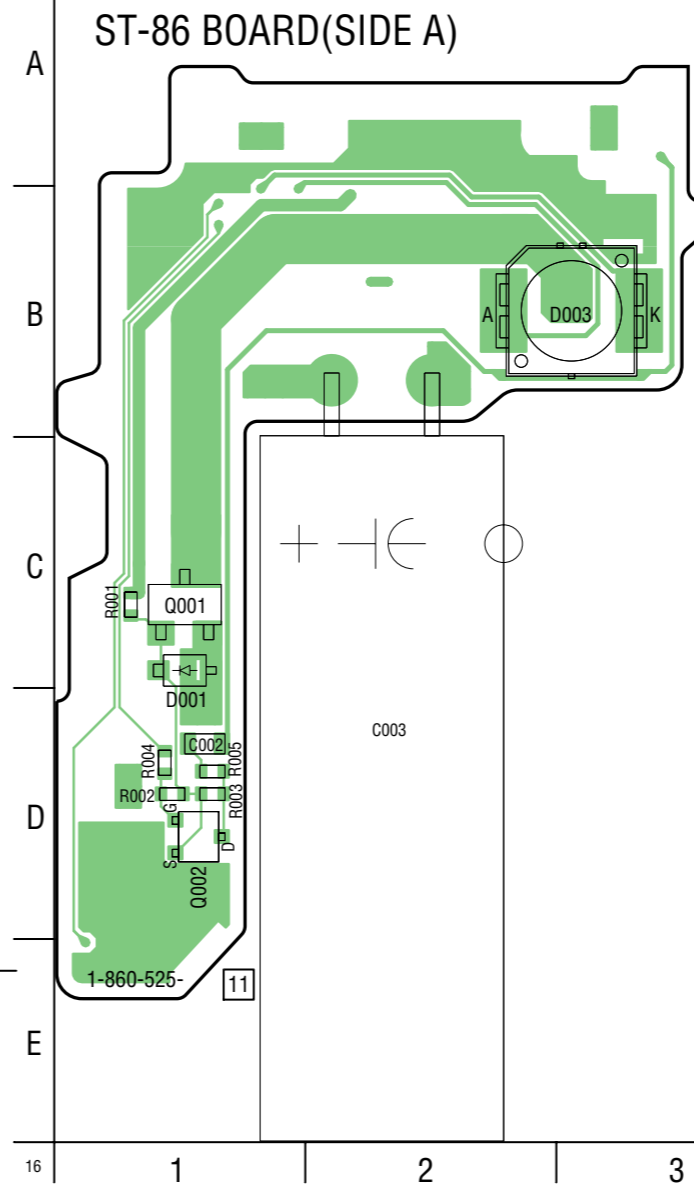

• Refer to page 4-39 for common note for printed wiring board. •  : Uses unleaded solder.

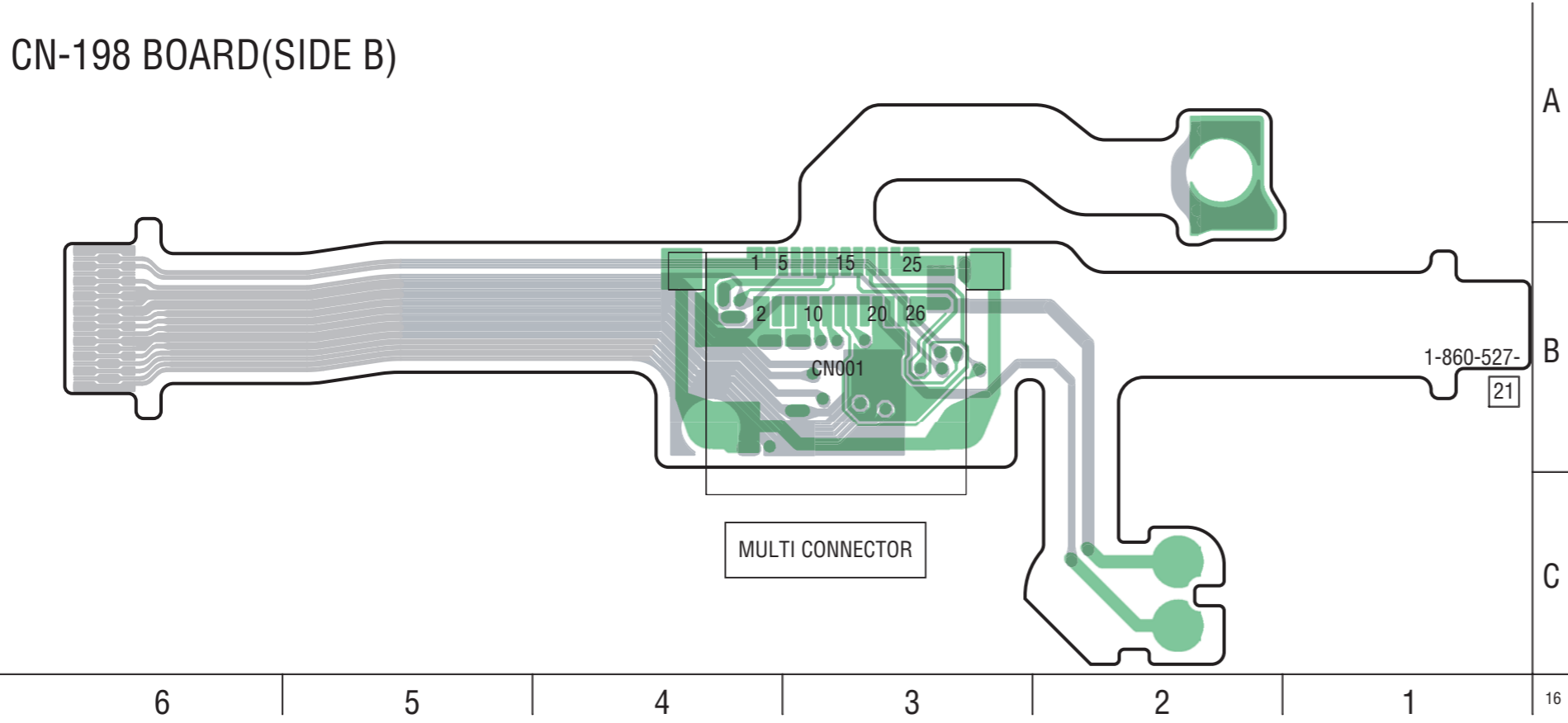
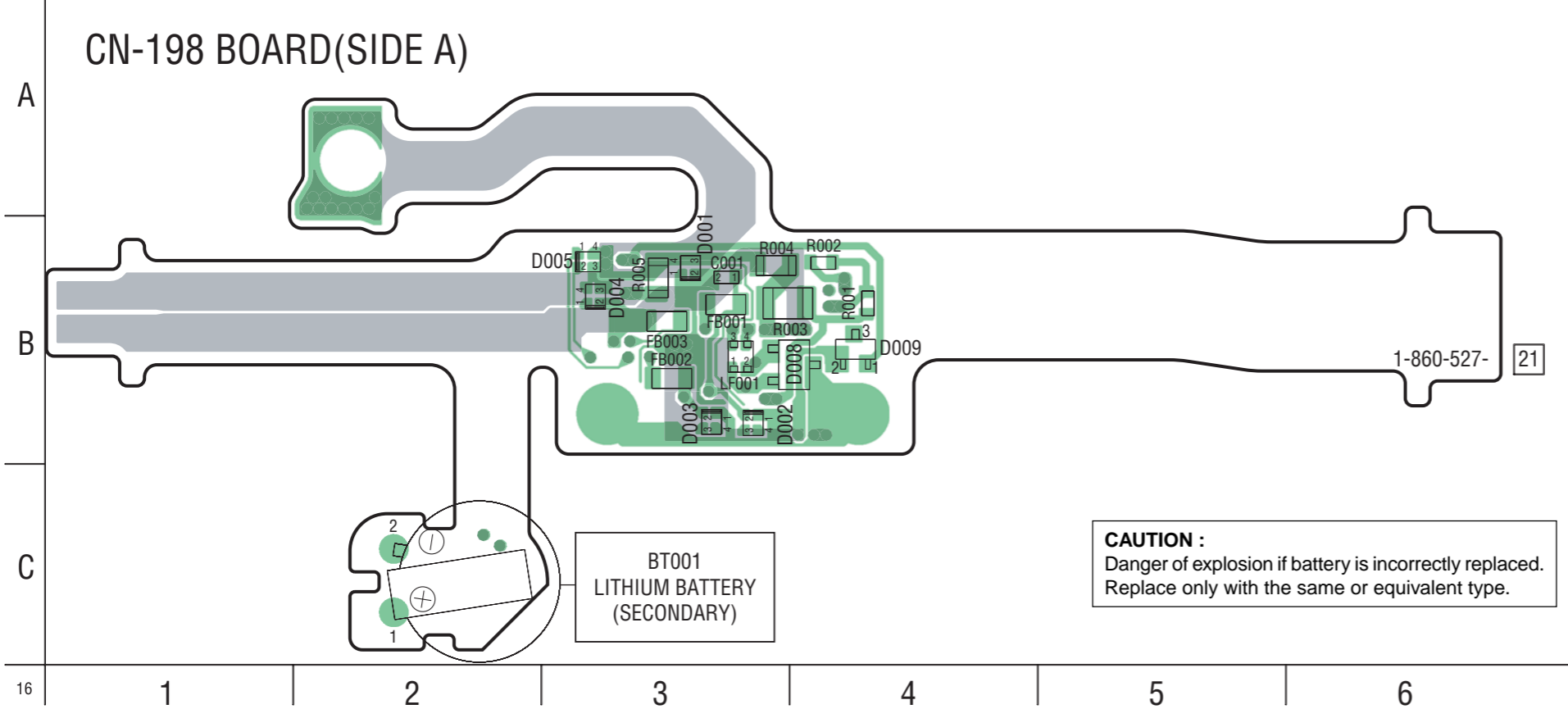

Printed wiring board of the FP-695, MS-148, SY-95 and FP-694 boards are not shown. Pages from 4-45 to 4-52 are not shown.

4-3. PRINTED WIRING BOARDS

4-4. MOUNTED PARTS LOCATION

no mark : side A
* mark : side B

CD-463 BOARD

C001 A-4
C002 A-5
C003 A-4
C004 A-4
C005 A-4

IC001 A-3

Q001 A-4
Q002 A-5
Q003 A-4
Q004 A-5

R001 A-4
R002 B-5
R003 A-4
R004 A-4
R005 A-4
R006 A-4

ST-86 BOARD

C002 D-1
C003 D-2
* C004 C-1

D001 C-1
* D002 C-1
D003 B-3

Q001 C-1
Q002 D-1
* Q003 D-1

R001 C-1
R002 D-1
R003 D-1
R004 D-1
R005 D-1
* R006 D-1
* R007 D-1
* R008 C-1

* T002 B-2

CN-198 BOARD

BT001 C-2

C001 B-3

* CN001 B-3

D001 B-3
D002 B-3
D003 B-3
D004 B-3
D005 B-3
D008 B-3
D009 B-4

FB001 B-3
FB002 B-3
FB003 B-3

LF001 B-3

R001 B-4
R002 B-4
R003 B-3
R004 B-3

Mounted parts location of the LD-140, MS-148,
and SY-95 boards are not shown.
Pages from 4-54 to 4-55 are not shown.

NOTE

5. REPAIR PARTS LIST

NOTE: Characters **A** to **Z** of the electrical parts list indicate location of exploded views in which the desired part is shown.

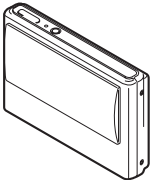
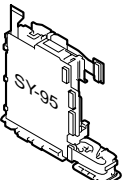
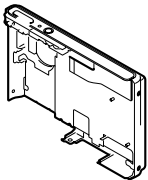
Link	EXPLODED VIEWS		
 <p data-bbox="485 651 507 680">A</p> <p data-bbox="256 712 485 741">OVERALL SECTION</p>	 <p data-bbox="804 651 826 680">B</p> <p data-bbox="555 712 826 741">BATTERY HOLDER SECTION</p>	 <p data-bbox="874 712 1145 741">CABINET (REAR) SECTION</p>	

Link	ELECTRICAL PARTS LIST			ACCESSORIES
<ul style="list-style-type: none"> CD-463 BOARD 	<ul style="list-style-type: none"> ST-86 BOARD A 	<ul style="list-style-type: none"> MS-148 BOARD B 		
<ul style="list-style-type: none"> CN-198 BOARD B 	<ul style="list-style-type: none"> LD-140 BOARD A 	<ul style="list-style-type: none"> SY-95 BOARD B 		

5. REPAIR PARTS LIST

NOTE:

- -XX, -X mean standardized parts, so they may have some differences from the original one.
- Items marked "*" are not stocked since they are seldom required for routine service. Some delay should be anticipated when ordering these items.
- The mechanical parts with no reference number in the exploded views are not supplied.
- Due to standardization, replacements in the parts list may be different from the parts specified in the diagrams or the components used on the set.
- CAPACITORS:
uF: μ F
- COILS
uH: μ H
- RESISTORS
All resistors are in ohms.
METAL: metal-film resistor
METAL OXIDE: Metal Oxide-film resistor
F: nonflammable
- SEMICONDUCTORS
In each case, u: μ , for example:
uA...: μ A... , uPA... , μ PA... ,
uPB... , μ PB... , uPC... , μ PC... ,
uPD... , μ PD...

When indicating parts by reference number, please include the board name.

The components identified by mark \triangle or dotted line with mark \triangle are critical for safety. Replace only with part number specified.

Les composants identifiés par une marque \triangle sont critiques pour la sécurité. Ne les remplacer que par une pièce portant le numéro spécifié.

5. REPAIR PARTS LIST

5-1. EXPLODED VIEWS

5-1-1. OVERALL SECTION

ns : not supplied

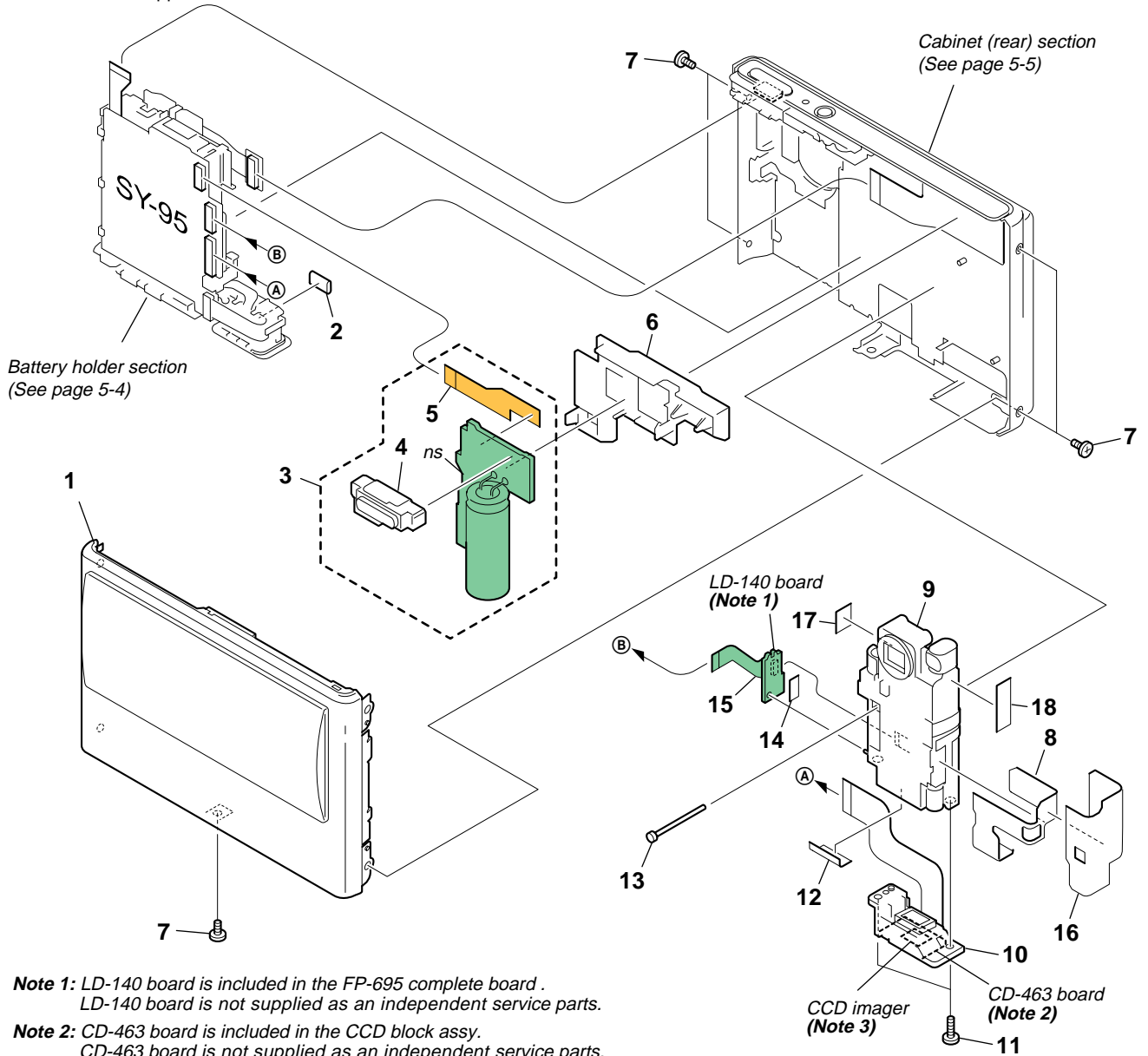

- Note 1:** LD-140 board is included in the FP-695 complete board .
LD-140 board is not supplied as an independent service parts.
- Note 2:** CD-463 board is included in the CCD block assy.
CD-463 board is not supplied as an independent service parts.
- Note 3:** The CCD imager is included in the CCD block assy .
The CCD imager is not supplied as a single unit since removing it as a single unit requires adjustment.

Be sure to read "Precautions upon replacing CCD imager" on page 4-5 when changing the CCD imager.

Ref. No.	Part No.	Description
1	X-3953-789-1	CABINET (FRONT) ASSY
2	3-087-670-01	GASKET (K)
3	A-7078-867-A	ST-86 BOARD, COMPLETE
△4	1-478-385-11	LUMINOUS UNIT, STROBOSCOPE
5	1-860-515-11	FP-690 FLEXIBLE BOARD
6	3-086-275-01	COVER, ST TERMINAL
7	3-086-218-01	SCREW (M1.4), LOCK ASE, SPECIAL
8	3-086-236-01	SHEET (CCD), RADIATION
9	A-7113-001-A	LENS ASSY (SERVICE EXCLUSIVE)

Ref. No.	Part No.	Description
10	A-7111-623-A	CCD BLOCK ASSY (Supplied with CD-463 board)
11	3-086-156-11	SCREW B1.2
12	3-086-238-01	SHEET (CCD), INSULATING
13	3-086-276-01	SHAFT, LENS
14	3-086-237-01	SHEET (LD), ADHESIVE
15	A-7078-877-A	FP-695 BOARD, COMPLETE
16	3-088-401-01	SHEET, PROTECTION, COPPER LEAF
17	3-089-986-01	SHEET (L), LIGHT INTERCEPTION
18	3-089-781-01	SHEET (MOTOR), PROTECTION

Note :
The components identified by mark △ or dotted line with mark △ are critical for safety. Replace only with part number specified.

Note :
Les composants identifiés par une marque △ sont critiques pour la sécurité. Ne les remplacer que par une pièce portant le numéro spécifié.

5. REPAIR PARTS LIST

5-1-2. BATTERY HOLDER SECTION

ns : not supplied

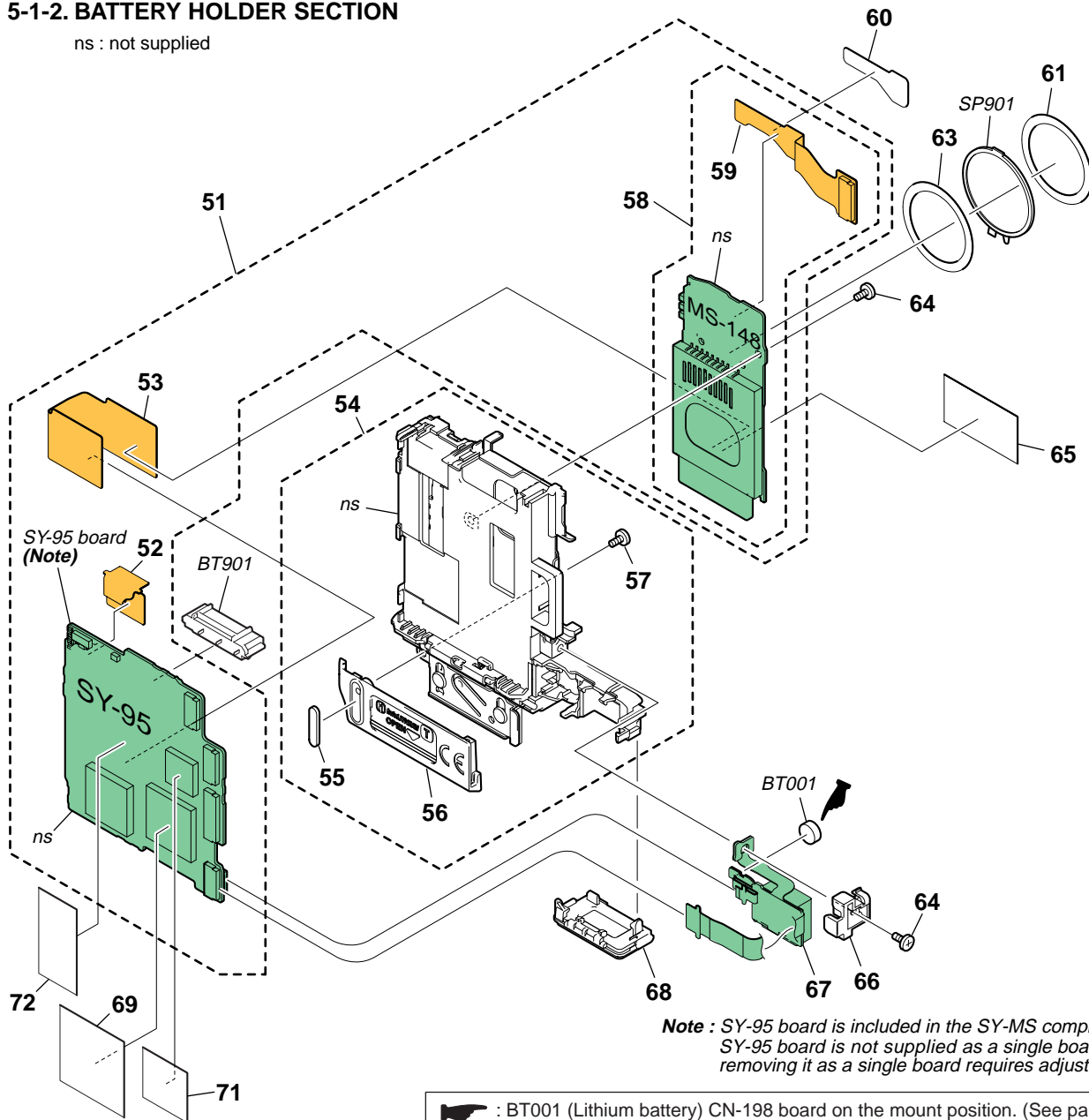

Note : SY-95 board is included in the SY-MS complete board .
SY-95 board is not supplied as a single board since removing it as a single board requires adjustment.

: BT001 (Lithium battery) CN-198 board on the mount position. (See page 4-43)

CAUTION :
Danger of explosion if battery is incorrectly replaced.
Replace only with the same or equivalent type.

Ref. No.	Part No.	Description
51	A-7079-000-A	SY-MS BOARD, COMPLETE (SERVICE)
52	1-860-517-11	FP-693 FLEXIBLE BOARD
53	1-860-516-11	FP-691 FLEXIBLE BOARD
54	X-3953-783-1	HOLDER ASSY, BATTERY
55	3-086-216-01	FOOT, RUBBER
56	3-086-210-02	LID, BT
57	3-355-424-01	SCREW, TAPPING
58	A-7078-865-A	MS-148 BOARD, COMPLETE
59	1-860-518-11	FP-694 FLEXIBLE BOARD
60	3-086-222-01	SHEET (S), PROTECTION, MS
61	3-086-752-01	CUSHION (RING)

Ref. No.	Part No.	Description
63	3-086-221-01	SHEET (SPEAKER), ADHESIVE
64	3-086-218-01	SCREW (M1.4), LOCK ASE, SPECIAL
65	3-086-223-01	SHEET (L), PROTECTION, MS
66	3-086-219-01	HOLDER, SY
67	A-7078-870-A	CN-198 BOARD, COMPLETE
68	3-086-217-01	CAP (MULTI)
69	3-089-013-02	SHEET (K), ELECTROTATIC
71	3-089-985-01	SHEET
72	3-086-220-01	SHEET (SY), SLIDE
BT901	1-780-061-11	TERMINAL BOARD, BATTERY
SP901	1-825-644-11	BUZZER, PIEZOELECTRIC

5. REPAIR PARTS LIST

5-1-3. CABINET (REAR) SECTION

ns : not supplied

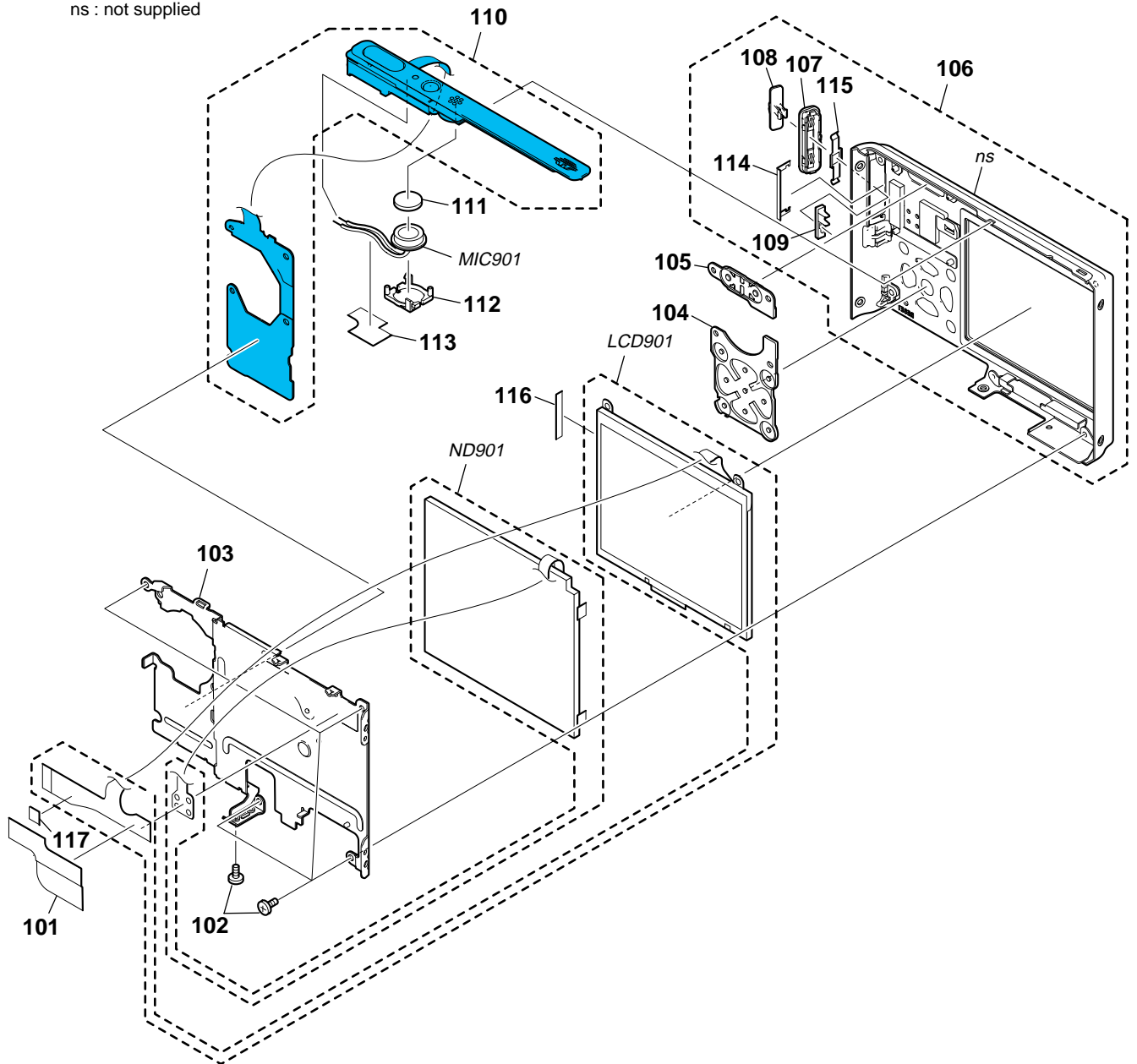

Ref. No.	Part No.	Description	Ref. No.	Part No.	Description
101	3-086-279-01	TAPE (LCD)	111	3-086-277-01	CUSHION, MICROPHONE
102	3-086-218-01	SCREW (M1.4), LOCK ASE, SPECIAL	112	3-086-274-01	HOLDER, MICROPHONE
103	3-086-234-01	FRAME, LCD	113	3-086-278-01	SHEET, PROTECTION, HARNESS
104	3-086-232-01	BUTTON, SW	114	3-086-206-01	SHEET METAL, MODE RETAINER
105	3-086-233-01	BUTTON, ZOOM	115	3-086-207-01	SPRING (MODE), CLICK
106	X-3953-782-1	CABINET (REAR) ASSY	116	3-088-260-01	SHEET (BL)
107	3-086-199-01	BASE, MODE	117	3-090-940-01	SHEET (LCD)
108	3-086-198-01	KNOB, MODE	LCD901	8-753-052-81	ACX500EN-J (2.5 INCH COLOR LCD UNIT)
109	3-086-200-01	SLIDER, MODE	MIC901	1-542-554-11	MICROPHONE
110	1-478-171-11	SWITCH BLOCK,CONTROL (PW-125)	ND901	1-478-250-11	BLOCK LIGHT GUIDE PLATE (2.5)

CD-463

CN-198

ST-86

5-2. ELECTRICAL PARTS LIST

Ref. No.	Part No.	Description
	A-7111-623-A	CCD BLOCK ASSY *****
	not supplied	CD-463 BOARD, COMPLETE ***** (CD-463 board is included in CCD BLOCK ASSY.)
		< CAPACITOR >
C001	1-107-826-11	CERAMIC CHIP 0.1uF 10% 16V
C002	1-107-826-11	CERAMIC CHIP 0.1uF 10% 16V
C003	1-107-826-11	CERAMIC CHIP 0.1uF 10% 16V
C004	1-164-845-11	CERAMIC CHIP 5PF 0.25PF 50V
C005	1-107-826-11	CERAMIC CHIP 0.1uF 10% 16V
		< IC >
IC001	not supplied	CCD IMAGER (Note)
		< TRANSISTOR >
Q001	8-729-029-14	TRANSISTOR DTC144EUA-T106
Q002	8-729-029-14	TRANSISTOR DTC144EUA-T106
Q003	8-729-052-64	TRANSISTOR DTC144EHT2L
Q004	8-729-050-22	TRANSISTOR 2SC4250 (T5LSONY1)
		< RESISTOR >
R001	1-218-955-11	RES-CHIP 1.5K 5% 1/16W
R002	1-218-969-11	RES-CHIP 22K 5% 1/16W
R003	1-218-960-11	RES-CHIP 3.9K 5% 1/16W
R004	1-218-956-11	RES-CHIP 1.8K 5% 1/16W
R005	1-218-954-11	RES-CHIP 1.2K 5% 1/16W
R006	1-218-990-11	SHORT CHIP 0
	A-7078-870-A	CN-198 BOARD, COMPLETE *****
		< BATTERY >
△ BT001	1-528-999-51	BATTERY (LITHIUM BATTERY (SECONDARY))
		< CAPACITOR >
C001	1-164-874-11	CERAMIC CHIP 100PF 5% 50V
		< CONNECTOR >
CN001	1-816-929-11	CONNECTOR, MULTIPLE 26P
		< DIODE >
D001	8-719-077-54	DIODE MA4L11100AS0
D002	8-719-077-57	DIODE DF3A8.2C (TPL3)
D003	8-719-077-57	DIODE DF3A8.2C (TPL3)
D004	8-719-077-57	DIODE DF3A8.2C (TPL3)
D005	8-719-077-57	DIODE DF3A8.2C (TPL3)
D009	8-719-077-57	DIODE DF3A8.2C (TPL3)
		< FERRITE BEAD >
FB001	1-500-284-21	INDUCTOR, FERRITE BEAD
FB002	1-500-284-21	INDUCTOR, FERRITE BEAD
FB003	1-414-228-11	INDUCTOR, FERRITE BEAD

Ref. No.	Part No.	Description
		< LINE FILTER >
LF001	1-456-583-11	COIL, COMMON MODE CHOKE
		< RESISTOR >
R001	1-218-973-11	RES-CHIP 47K 5% 1/16W
R002	1-218-977-11	RES-CHIP 100K 5% 1/16W
R003	1-216-295-91	SHORT CHIP 0
R004	1-216-864-11	SHORT CHIP 0
	A-7078-867-A	ST-86 BOARD, COMPLETE *****
△	1-478-385-11	LUMINOUS UNIT, STROBO SCOPE
	1-860-515-11	FP-690 FLEXIBLE BOARD
		< CAPACITOR >
C002	1-162-970-11	CERAMIC CHIP 0.01uF 10% 25V
△ C003	1-100-760-11	ELECT 63uF 99% 315V
C004	1-137-723-21	CERAMIC CHIP 0.047uF 10% 250V
		< DIODE >
D001	8-719-073-01	DIODE MA111-(K8).S0
△ D002	6-500-237-01	DIODE HAU160C030TP
D003	6-500-804-01	DIODE S4G49 (SONY)
		< TRANSISTOR >
Q001	6-550-308-01	TRANSISTOR CPH3205-SONY-TL-E
Q002	8-729-056-01	TRANSISTOR MCH3405-TL-E
Q003	8-729-053-74	TRANSISTOR CY25AAJ-8-T13
		< RESISTOR >
R001	1-218-961-11	RES-CHIP 4.7K 5% 1/16W
R002	1-218-977-11	RES-CHIP 100K 5% 1/16W
R003	1-218-942-11	RES-CHIP 120 5% 1/16W
R004	1-218-965-11	RES-CHIP 10K 5% 1/16W
R005	1-218-944-11	RES-CHIP 180 5% 1/16W
R006	1-216-805-11	METAL CHIP 47 5% 1/10W
R007	1-216-857-11	METAL CHIP 1M 5% 1/10W
R008	1-216-121-11	RES-CHIP 1M 5% 1/10W
		< TRANSFORMER >
△ T002	1-437-987-31	TRANSFORMER , CONVERTER

Be sure to read "Precautions upon replacing CCD imager" on page 4-7 when changing the CCD imager.

Note :
The CCD imager is not supplied as a single unit since removing it as a single unit requires adjustment.

CAUTION :
Danger of explosion if battery is incorrectly replaced. Replace only with the same or equivalent type.

Note :
The components identified by mark △ or dotted line with mark △ are critical for safety. Replace only with part number specified.

Note :
Les composants identifiés par une marque △ sont critiques pour la sécurité. Ne les remplacer que par une pièce portant le numéro spécifié.

<u>Ref. No.</u>	<u>Part No.</u>	<u>Description</u>
	A-7078-877-A	FP-695 BOARD, COMPLETE *****
	not supplied	LD-140 BOARD, COMPLETE ***** (LD-140 board is included in FP-695 board)



	A-7078-865-A	MS-148 BOARD, COMPLETE ***** (CN402 is not included in this complete board.)
--	--------------	--



	A-7079-000-A	SY-MS BOARD, COMPLETE (SERVICE) *****
	not supplied	SY-95 BOARD, COMPLETE ***** (MS-148 board and SY-95 board are included in SY-MS board.) (IC301 is not included in this complete board.)



Electrical parts list of the LD-140, MS-148 and SY-95 boards are not shown. Pages from 5-7 to 5-11 are not shown.

Checking supplied accessories.

Make sure that the following accessories are supplied with your camcorder.



Power cord (Main lead) (1)
(AUS model)
△ 1-696-819-11
Power cord (Main lead) (1)
(AEP, E model)
△ 1-769-608-11
Power cord (Main lead) (1)
(CH model)
△ 1-782-476-13
Power cord (Main lead) (1)
(UK, HK model)
△ 1-783-374-11
Power cord (Main lead) (1)
(JE model)
△ 1-790-732-12
Power cord (Main lead) (1)
(J model)
△ 1-791-637-13
Power cord (Main lead) (1)
(KR model)
△ 1-776-985-11
Power cord (Main lead) (1)
(US, CND model)
△ 1-790-107-22

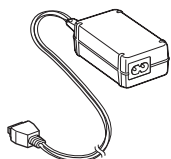

AC-LM5 AC Adaptor (1)
(Except US, CND)
△ 1-477-488-12
AC-LM5 AC Adaptor (1)
(US, CND)
△ 1-477-488-21

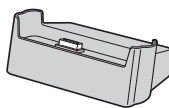

UC-TA USB cradle (1)
1-817-742-11



USB cable (1)
1-828-073-11



CD-ROM
(USB Driver SPVD-013) (1)
(AEP, UK, E, HK, AUS, CH,
JE, KR model)
3-087-330-01
CD-ROM
(USB Driver SPVD-013 (II)) (1)
(US, CND, J model)
3-087-331-01

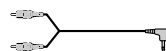

A/V connecting cable (1)
1-824-111-11



Wrist strap (1)
3-086-283-01

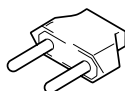

2-pin conversion adaptor (1)
(JE model)
1-569-007-12

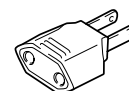

2-pin conversion adaptor (1)
(E, HK model)
1-569-008-12

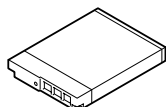

NP-FT1 battery pack (1)
(not supplied)



"Memory stick Duo" (1)
(MSA-M32A)
(not supplied)



Memory stick Duo Adaptor(1)
(MSAC-M2)
(not supplied)

- Abbreviation
- CND : Canadian model
- AUS : Australian model
- CH : Chinese model
- HK : Hong Kong model
- KR : Korea model
- JE : Tourist model
- J : Japanese model

Other accessories

- 3-085-733-01 MANUAL, INSTRUCTION SET (JAPANESE) (J)
- 3-085-733-11 MANUAL, INSTRUCTION SET (ENGLISH) (EXCEPT KR, J)
- 3-085-733-21 MANUAL, INSTRUCTION SET (FRENCH/GERMAN)
(CND, AEP)
- 3-085-733-31 MANUAL, INSTRUCTION SET (SPANISH/PORTUGUESE)
(AEP, E, JE)
- 3-085-733-41 MANUAL, INSTRUCTION SET (ITALIAN/DUTCH) (AEP)
- 3-085-733-51 MANUAL, INSTRUCTION SET (CHINESE) (E, HK, CH, JE)

- 3-085-733-61 MANUAL, INSTRUCTION SET (RUSSIAN/SWEDISH) (AEP)
- 3-085-733-71 MANUAL, INSTRUCTION SET (ARABIC) (E)
- 3-085-733-81 MANUAL, INSTRUCTION SET (KOREAN) (JE, KR)
- 3-085-734-01 MANUAL, INSTRUCTION (for PC)(JAPANESE) (J)

Note :
The components identified by mark △ or dotted line with mark △ are critical for safety. Replace only with part number specified.

Note :
Les composants identifiés par une marque △ sont critiques pour la sécurité. Ne les remplacer que par une pièce portant le numéro spécifié.

DSC-T1

SONY®

LEVEL 2

SERVICE MANUAL

Ver 1.1 2004.03

US Model
Canadian Model
AEP Model
UK Model
E Model
Hong Kong Model
Australian Model
Korea Model
Chinese Model
Tourist Model
Japanese Model





SUPPLEMENT-1

File this supplement-1 with the service manual.
(PV03-016)

- Addition of Black Model.

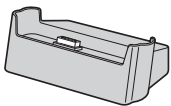

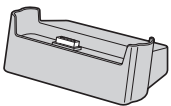

















5. REPAIR PARTS LIST

 : Added portion.

Page	Before change	After change
5-12E	<p>Checking supplied accessories.</p>  <p>UC-TA USB cradle (1) 1-817-742-11</p>  <p>Wrist strap (1) 3-086-283-01</p>	 <p>UC-TA USB cradle (1) 1-817-742-11 (SILVER) 1-817-742-21 (BLACK)</p>  <p>Wrist strap (1) 3-086-283-01 (SILVER) 3-086-283-11 (BLACK)</p>

5-1. EXPLODED VIEWS

 : Added portion.

Page	Before change			After change		
5-3	5-1-1. OVERALL SECTION					
	<u>Ref. No.</u>	<u>Part No.</u>	<u>Description</u>	<u>Ref. No.</u>	<u>Part No.</u>	<u>Description</u>
	1	X-3953-789-1	CABINET (FRONT) ASSY	1	X-3953-789-1	CABINET (FRONT) ASSY (SILVER) 
			1	X-2021-386-1	CABINET (FRONT) (B) ASSY (BLACK)	
	7	3-086-218-01	SCREW (M1.4), LOCK ASE, SPECIAL	7	3-086-218-01	SCREW (M1.4), LOCK ASE, SPECIAL (SILVER) 
				7	3-086-218-11	SCREW (M1.4), LOCK ASE, SPECIAL (BLACK) 
5-4	5-1-2. BATTERY HOLDER SECTION					
	54	X-3953-783-1	HOLDER ASSY, BATTERY	54	X-3953-783-1	HOLDER ASSY, BATTERY (SILVER) 
				54	X-2021-390-1	HOLDER (B) ASSY, BATTERY (BLACK)
	56	3-086-210-01	LID, BT	56	3-086-210-01	LID, BT (SILVER) 
			56	3-086-210-11	LID, BT (BLACK) 	
	68	3-086-217-01	CAP (MULTI)	68	3-086-217-01	CAP (MULTI) (SILVER) 
			68	3-086-217-11	CAP (MULTI) (BLACK) 	
5-5	5-1-3. CABINET (REAR) SECTION					
	104	3-086-232-01	BUTTON, SW	104	3-086-232-01	BUTTON, SW (SILVER) 
				104	3-086-232-11	BUTTON, SW (BLACK) 
	105	3-086-233-01	BUTTON, ZOOM	105	3-086-233-01	BUTTON, ZOOM (SILVER) 
				105	3-086-233-11	BUTTON, ZOOM (BLACK) 
	106	X-3953-782-1	CABINET (REAR) ASSY	106	X-3953-782-1	CABINET (REAR) ASSY (SILVER) 
				106	X-2021-388-1	CABINET (REAR) (B) ASSY (BLACK) 
	107	3-086-199-01	BASE, MODE	107	3-086-199-01	BASE, MODE (SILVER) 
				107	3-086-199-11	BASE, MODE (BLACK) 
	108	3-086-198-01	KNOB, MODE	108	3-086-198-01	KNOB, MODE (SILVER) 
			108	3-086-198-11	KNOB, MODE (BLACK) 	
	110	1-478-171-11	SWITCH BLOCK,CONTROL (PW-125)	110	1-478-171-11	SWITCH BLOCK,CONTROL (PW-125) (SILVER) 
				110	1-478-171-21	SWITCH BLOCK, CONTROL (PW-125) (BLACK) 

DSC-T1

SONY®

LEVEL 2

SERVICE MANUAL

Ver 1.2 2004.03



US Model
 Canadian Model
 AEP Model
 UK Model
 E Model
 Hong Kong Model
 Australian Model
 Korea Model
 Chinese Model
 Tourist Model
 Japanese Model







SUPPLEMENT-2

File this supplement-2 with the service manual.
 (PV03-018)

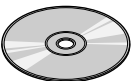
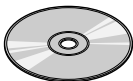
- Change of parts number.
- Addition of Accessory.

5. REPAIR PARTS LIST

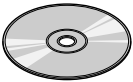
 : Changed portion.  : Added portion.

Page	Before change	After change
5-12E	<p>Checking supplied accessories.</p>  <p>CD-ROM (USB Driver SPVD-013) (1) (AEP, UK, E, HK, AUS, CH, JE, KR model) 3-087-330-01 CD-ROM (USB Driver SPVD-013 (I)) (1) (US, CND, J model) 3-087-331-01</p>	 <p>CD-ROM (USB Driver SPVD-013) (1) (AEP, UK, E, HK, AUS, CH, JE, KR model) 3-087-330-11  CD-ROM  (USB Driver SPVD-013 (I)) (1) (US, CND, J model) 3-087-331-11 </p> <div style="border: 1px dashed black; padding: 5px; margin-top: 20px;">  <p>UPDATE CD-ROM (PB), T1 3-091-965-01 </p> </div>

[Description of main button functions on toolbar of the Adobe Acrobat Reader Ver5.0 (for Windows)]



Toolbar



Printing a text

1. Click the Print button .
2. Specify a printer, print range, number of copies, and other options, and then click [OK].

Application of printing:

To set a range to be printed within a page, select the graphic selection tool  and drag on the page to enclose a range to be printed, and then click the Print button.

Reversing the screens displayed once

- To reverse the previous screens (operation) one by one, click the .
- To advance the reversed screens (operation) one by one, click the .

Application to the Service Manual:

This function allows you to go and back between circuit diagram and printed circuit board diagram, and accordingly it will be convenient for the voltage check.

Finding a text

1. Click the Find button .
2. Enter a character string to be found into a text box, and click the [Find]. (Specify the find options as necessary)

Application to the Service Manual:

To execute "find" from current page toward the previous pages, select the check box "Find Backwards" and then click the "Find".

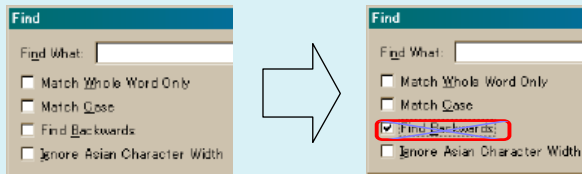





3. Open the find dialog box again, and click the [Find Again] and you can find the matched character strings displayed next. (Character strings entered previously are displayed as they are in the text box.)

Application to the Service Manual:

The parts on the drawing pages (block diagrams, circuit diagrams, printed circuit boards) and parts list pages in a text can be found using this find function. For example, find a Ref. No. of IC on the block diagram, and click the [Find Again] continuously, so that you can move to the Ref. No. of IC on the circuit diagram or printed circuit board diagram successively.

Note: The find function may not be applied to the Service Manual depending on the date of issue.

Moving with link

1. Select either palm tool , zoom tool , text selection tool , or graphic selection tool .
2. Place the pointer in the position in a text where the link exists (such as a button on cover and the table of contents page, or blue characters on the removal flowchart page or drawing page), and the pointer will change to the forefinger form .
3. Then, click the link. (You will go to the link destination.)

Moving with bookmark:

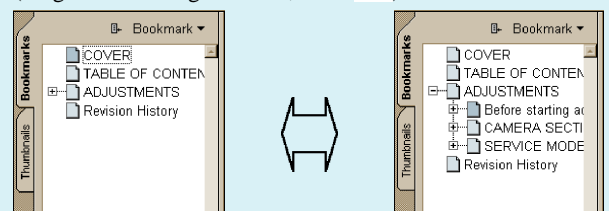

Click an item (text) on the bookmark pallet. and you can move to the link destination. Also, clicking  can display the hidden items.

(To go back to original state, click )



Zooming or rotating the screen display

"Zoom in/out"

- Click the triangle button in the zoom control box to select the display magnification. Or, you may click  or  for zooming in or out.







"Rotate"

- Click rotate tool , and the page then rotates 90 degrees each.

Application to the Service Manual:

The printed circuit board diagram you see now can be changed to the same direction as the set.

Switching a page

- To move to the first page, click the .
- To move to the last page, click the .
- To move to the previous page, click the .
- To move to the next page, click the .

Revision History

Ver.	Date	History	Contents	S.M. Rev. issued
1.0	2003.10	Official Release	—	—
1.1	2004.03	Supplement-1	Addition of Black Model	No
1.2	2004.03	Supplement-2	<ul style="list-style-type: none">• Change of parts number.• Addition of Accessory.	No
1.3	2004.04	Revised-1	<ul style="list-style-type: none">• Addition of Suplied parts.• Addtion of Error code.• Part number suffix of CD-463 board is changed to 12.	Yes