

# DSC-S75

## SERVICE MANUAL

Level 2

*Self Diagnosis*  
Supported model

Ver 1.3 2001.11  
Cyber-shot

Digital Still Camera

InfoLITHIUM M



MEMORY STICK



US Model  
Canadian Model  
AEP Model  
UK Model  
E Model  
Hong Kong Model  
Australian Model  
Chinese Model  
Korea Model  
Tourist Model  
Japanese Model

This service manual contains information for Japanese model as well.

### On the SY-68 board

This service manual provides the information that is premised the circuit board replacement service and not intended repair inside the SY-68 board.

Therefore, schematic diagram, printed wiring board and electrical parts list of the SY-68 board are not shown.  
The following pages are not shown.

### SY-68 board

Schematic diagram ..... Pages 4-11 to 4-30  
Printed wiring board ..... Pages 4-7 to 4-10  
Electrical parts list ..... Pages 6-8 to 6-13

The above-described information is shown in service manual Level 3.

## SPECIFICATIONS

### System

#### Image device

8.93 mm (1/1.8 type) color  
CCD

#### Lens

3× zoom lens  
f = 7 – 21 mm (9/32 – 27/32  
inches)  
(34 – 102 mm (1 3/8 – 4 1/8  
inches) when converted into a  
35 mm still camera)  
F = 2.0 – 2.5

#### Exposure control

Automatic exposure, Shutter  
speed priority, Aperture  
priority, Manual exposure

#### White balance

Automatic, Indoor, Outdoor,  
One-push

#### Data system

Movie: MPEG1  
Still: JPEG, GIF (in TEXT  
mode, Clip Motion), TIFF  
Audio with still image:  
MPEG1 (Monaural)

#### Recording medium

“Memory Stick”

### Flash

Recommended recording  
distance (ISO is set to AUTO):  
0.3 m to 3.0 m (11 7/8 inches  
to 9 feet 10 1/8 inches)

#### Output connector A/V OUT (Monaural)

Minijack  
Video: 1 Vp-p, 75 Ω,  
unbalanced, sync negative  
Audio: 327 mV (at a 47 kΩ  
load)

Output impedance: 2.2 kΩ

#### USB jack

mini-B

#### External flash jack

Minijack

#### LCD screen

##### Used LCD panel

1.8 type TFT (Thin Film  
Transistor active matrix) drive

##### Total number of dots

123 200 (560×220) dots

### General

#### Used battery pack

NP-FM50

#### Power requirements

7.2 V

#### Power consumption (during recording)

3.0 W

#### Operation temperature

0°C to 40°C  
(32°F to 104°F)

#### Storage temperature

–20°C to +60°C  
(–4°F to +140°F)

#### Maximum dimensions

117×71×64 mm  
(4 5/8×2 7/8×2 5/8 inches)  
(w/h/d)

#### Mass

Approx. 462 g (1 lb)  
(including battery pack NP-  
FM50, “Memory Stick,”  
shoulder strap and lens cap  
etc.)

#### Built-in microphone

Electret condenser microphone

#### Built-in speaker

Dynamic speaker

### AC-L10A/B/C

#### AC power adaptor

##### Power requirements

100 to 240 V AC, 50/60 Hz

##### Rated output voltage

DC 8.4 V, 1.5 A in operating  
mode

##### Operation temperature

0°C to 40°C (32°F to 104°F)

##### Storage temperature

–20°C to +60°C  
(–4°F to +140°F)

##### Maximum dimensions

125×39×62 mm  
(5×1 9/16×2 1/2 inches)  
(w/h/d)

##### Mass

Approx. 280 g (10 oz)

### NP-FM50 battery pack

#### Used battery

Lithium ion battery

##### Maximum voltage

DC 8.4 V

##### Nominal voltage

DC 7.2 V

##### Capacity

8.5 Wh (1 180 mAh)

### Accessories

A/V connecting cable (1)  
NP-FM50 battery pack (1)  
AC-L10A AC power adaptor  
(1)  
Power cord (1)  
USB cable (1)  
Lens cap (1)  
Lens cap strap (1)  
Shoulder strap (1)  
“Memory Stick” (8 MB) (1)  
CD-ROM (2)  
Operating Instructions (1)

Design and specifications are  
subject to change without  
notice.

DIGITAL STILL CAMERA

SONY®

#### SAFETY-RELATED COMPONENT WARNING!!

COMPONENTS IDENTIFIED BY MARK  $\triangle$  OR DOTTED LINE WITH MARK  $\triangle$  ON THE SCHEMATIC DIAGRAMS AND IN THE PARTS LIST ARE CRITICAL TO SAFE OPERATION. REPLACE THESE COMPONENTS WITH SONY PARTS WHOSE PART NUMBERS APPEAR AS SHOWN IN THIS MANUAL OR IN SUPPLEMENTS PUBLISHED BY SONY.

#### ATTENTION AU COMPOSANT AYANT RAPPORT À LA SÉCURITÉ!

LES COMPOSANTS IDENTIFIÉS PAR UNE MARQUE  $\triangle$  SUR LES DIAGRAMMES SCHÉMATIQUES ET LA LISTE DES PIÈCES SONT CRITIQUES POUR LA SÉCURITÉ DE FONCTIONNEMENT. NE REMPLACER CES COMPOSANTS QUE PAR DES PIÈCES SONY DONT LES NUMÉROS SONT DONNÉS DANS CE MANUEL OU DANS LES SUPPLÉMENTS PUBLIÉS PAR SONY.

### SAFETY CHECK-OUT

After correcting the original service problem, perform the following safety checks before releasing the set to the customer.

1. Check the area of your repair for unsoldered or poorly-soldered connections. Check the entire board surface for solder splashes and bridges.
2. Check the interboard wiring to ensure that no wires are "pinched" or contact high-wattage resistors.
3. Look for unauthorized replacement parts, particularly transistors, that were installed during a previous repair. Point them out to the customer and recommend their replacement.
4. Look for parts which, though functioning, show obvious signs of deterioration. Point them out to the customer and recommend their replacement.
5. Check the B+ voltage to see it is at the values specified.
6. Flexible Circuit Board Repairing
  - Keep the temperature of the soldering iron around 270 °C during repairing.
  - Do not touch the soldering iron on the same conductor of the circuit board (within 3 times).
  - Be careful not to apply force on the conductor when soldering or unsoldering.

#### UNLEADED SOLDER

Boards requiring use of unleaded solder are printed with the lead-free mark (LF) indicating the solder contains no lead.

(Caution: Some printed circuit boards may not come printed with the lead free mark due to their particular size)

#### : LEAD FREE MARK

Unleaded solder has the following characteristics.

- Unleaded solder melts at a temperature about 40 °C higher than ordinary solder.  
Ordinary soldering irons can be used but the iron tip has to be applied to the solder joint for a slightly longer time.  
Soldering irons using a temperature regulator should be set to about 350 °C .  
Caution: The printed pattern (copper foil) may peel away if the heated tip is applied for too long, so be careful!
- Strong viscosity  
Unleaded solder is more viscous (sticky, less prone to flow) than ordinary solder so use caution not to let solder bridges occur such as on IC pins, etc.
- Usable with ordinary solder  
It is best to use only unleaded solder but unleaded solder may also be added to ordinary solder.

## TABLE OF CONTENTS

<u>Section</u>	<u>Title</u>	<u>Page</u>	<u>Section</u>	<u>Title</u>	<u>Page</u>
SERVICE NOTE .....		5	5.	ADJUSTMENTS	
Self-diagnosis Display .....		6	Before Starting Adjustment .....		5-1
1. GENERAL			1-1. Adjusting Items when Replacing		
Introduction .....		1-1	Main Parts and Boards .....		5-2
Identifying the Parts .....		1-2	5-1. Camera Section Adjustment .....		5-3
Preparing the Power Supply .....		1-2	1-1. Preparations Before Adjustment .....		5-3
Setting the Date and Time .....		1-3	1-1-1. List of Service Tools .....		5-3
Inserting the "Memory Stick" .....		1-4	1-1-2. Preparations .....		5-4
Basic operations .....		1-4	1-1-3. Discharging of the Flashlight Power Supply .....		5-4
Recording Still Images .....		1-4	1-1-4. Precautions .....		5-6
Recording Moving Images .....		1-6	1. Setting the Switch .....		5-6
Playing Back Still Images .....		1-7	2. Order of Adjustments .....		5-6
Playing Back Moving Images .....		1-7	3. Subjects .....		5-6
Viewing Images Using a Personal Computer .....		1-7	4. Preparing the Flash Adjustment Box .....		5-7
Image File Storage Destinations and Image Files .....		1-9	1-2. Initialization of B, D, E, F, 7, 9 Page Data .....		5-8
Before Performing Advanced Operations .....		1-10	1-2-1. Initialization of D Page Data .....		5-8
Various Recording .....		1-12	1. Initializing D Page Data .....		5-8
Various Playback .....		1-15	2. Modification of D Page Data .....		5-8
Editing .....		1-16	3. D Page Table .....		5-8
Additional Information .....		1-19	1-2-2. Initialization of B, E, F, 7, 9 Page Data .....		5-9
Troubleshooting .....		1-20	1. Initializing B, E, F, 7, 9 Page Data .....		5-9
Warning and Notice Messages .....		1-22	2. Modification of B, E, F, 7, 9 Page Data .....		5-9
Self-diagnosis Display .....		1-22	3. B Page Table .....		5-9
Display Window Indicators .....		1-23	4. E Page Table .....		5-9
LCD Screen Indicators .....		1-23	5. F Page Table .....		5-10
			6. 7 Page Table .....		5-12
			7. 9 Page Table .....		5-12
			1-3. Video System Adjustments .....		5-13
			1. Video Sync Level Adjustment .....		5-13
			2. Video Burst Level Adjustment .....		5-13
			1-4. Camera System Adjustment .....		5-14
			1. Flange Back Adjustment (Using the Minipattern Box) ..		5-15
			2. Flange Back Adjustment		
			(Using the Flange Back Adjustment Chart) .....		5-16
			3. Flange Back Check .....		5-17
			4. Picture Frame Setting .....		5-18
			5. F No. Standard Data Input .....		5-19
			6. Mechanical Shutter Adjustment .....		5-19
			7. Light Level Adjustment .....		5-20
			8. Mixed Color Cancel Adjustment .....		5-20
			9. Auto White Balance Standard Data Input .....		5-21
			10. Auto White Balance Adjustment .....		5-22
			11. Color Reproduction Adjustment .....		5-23
			12. Color Reproduction Check .....		5-24
			13. Auto White Balance Check .....		5-25
			14. CCD White Defect Compensation .....		5-26
			15. CCD Black Defect Compensation .....		5-27
			16. Strobe White Balance Adjustment .....		5-28
			1-5. LCD System Adjustments .....		5-29
			1. LCD Initial Data Input (1) .....		5-30
			2. LCD Initial Data Input (2) .....		5-30
			3. VCO Adjustment (SY-68 Board) .....		5-31
			4. D Range Adjustment (SY-68 Board) .....		5-31
			5. Bright Adjustment (SY-68 Board) .....		5-32
			6. Contrast Adjustment (SY-68 Board) .....		5-33
			7. Color Adjustment (SY-68 Board) .....		5-33
			8. V-COM Level Adjustment (SY-68 Board) .....		5-34
			9. V-COM Adjustment (SY-68 Board) .....		5-34
			10. White Balance Adjustment (SY-68 Board) .....		5-35
			5-2. Service Mode .....		5-36
			2-1. Adjusting Remote Commander .....		5-36
			1. Used the Adjusting Remote Commander .....		5-36
			2. Precautions upon Using		
			the Adjusting Remote Commander .....		5-36
			2-2. Data Process .....		5-37
			2-3. Service Mode .....		5-38
			1. Setting the Test Mode .....		5-38
			2. Bit Value Discrimination .....		5-38
			3. Mode Dial Check (1) .....		5-39
			4. Mode Dial Check (2) .....		5-39
			5. Jog Dial Check .....		5-39
2. DISASSEMBLY					
2-1. Cabinet (Rear) Block Assembly .....		2-1			
2-2. Lens Block Assembly .....		2-1			
2-3. DM-101 Board .....		2-2			
2-4. CK-103 Board .....		2-2			
2-5. Control Switch Block (Zoom), LCD Panel					
(Character Display) .....		2-2			
2-6. LCD Module .....		2-2			
2-7. Circuit Boards Location .....		2-4			
2-8. Flexible Boards Location .....		2-4			
3. BLOCK DIAGRAMS					
3-1. Overall Block Diagram .....		3-1			
3-8. Power Block Diagram 1 .....		3-15			
3-9. Power Block Diagram 2 .....		3-17			
4. PRINTED WIRING BOARDS AND SCHEMATIC DIAGRAMS					
4-1. Frame Schematic Diagrams .....		4-3			
Frame Schematic Diagram (1/2) .....		4-3			
Frame Schematic Diagram (2/2) .....		4-5			
4-2. Printed Wiring Boards and Schematic Diagrams .....		4-31			
CK-103 Printed Wiring Board and					
Schematic Diagram .....		4-31			
JK-211 Printed Wiring Board and					
Schematic Diagram .....		4-33			
KY-55 Printed Wiring Board and Schematic Diagram ..		4-35			
DM-101 Printed Wiring Board .....		4-37			
DM-101 (DC/DC CONVERTER) Schematic Diagram ..		4-39			
DM-101 (MS SOCKET) Schematic Diagram .....		4-41			
4-4. Parts Location .....		4-46			

<u>Section</u>	<u>Title</u>	<u>Page</u>
6.	Switch Check (1) .....	5-39
7.	Switch Check (2) .....	5-40
8.	LED, LCD Check .....	5-40
9.	Self Diagnosis Code .....	5-40
6.	REPAIR PARTS LIST	
6-1.	Exploded Views .....	6-1
6-1-1.	Main Section .....	6-1
6-1-2.	Cabinet (Front) Block Assembly .....	6-2
6-1-3.	Lens Block Assembly .....	6-3
6-1-4.	Cabinet (Rear) Block Assembly .....	6-4
6-2.	Electrical Parts List.....	6-5

* The color reproduction frame is shown on page 109.
--

## SERVICE NOTE

### • NOTE FOR REPAIR

Make sure that the flat cable and flexible board are not cracked or bent at the terminal.

Do not insert the cable insufficiently nor crookedly.

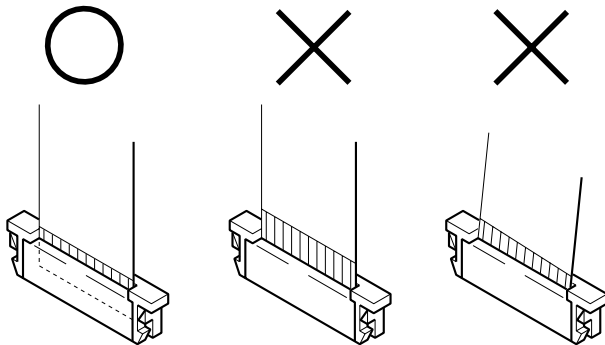

Cut and remove the part of gilt which comes off at the point.  
(Be careful or some pieces of gilt may be left inside)

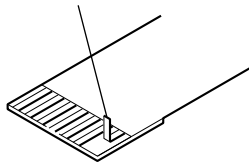

When remove a connector, don't pull at wire of connector. It is possible that a wire is snapped.

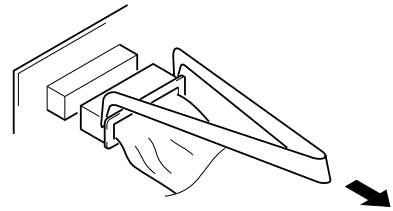

When installing a connector, don't press down at wire of connector. It is possible that a wire is snapped.

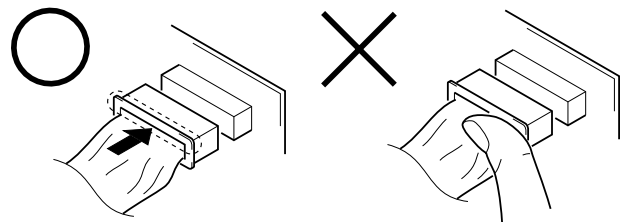

### [Discharging of the FLASH unit's charging capacitor]

The charging capacitor of the FLASH unit is charged up to the maximum 300 V potential.

There is a danger of electric shock by this high voltage when the battery is handled by hand. The electric shock is caused by the charged voltage which is kept without discharging when the main power of the DSC-S75 is simply turned off. Therefore, the remaining voltage must be discharged as described below.

#### Preparing the Short Jig

To preparing the short jig, a small clip is attached to each end of a resistor of 1 k $\Omega$  / 1 W (1-215-869-11).

Wrap insulating tape fully around the leads of the resistor to prevent electrical shock.

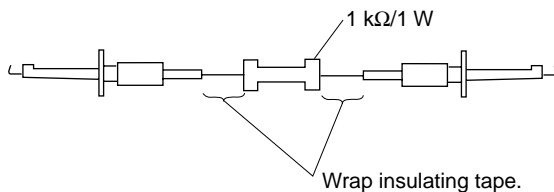

### Discharging the Capacitor

Short-circuit between the positive and the negative terminals of charged capacitor with the short jig about 10 seconds.

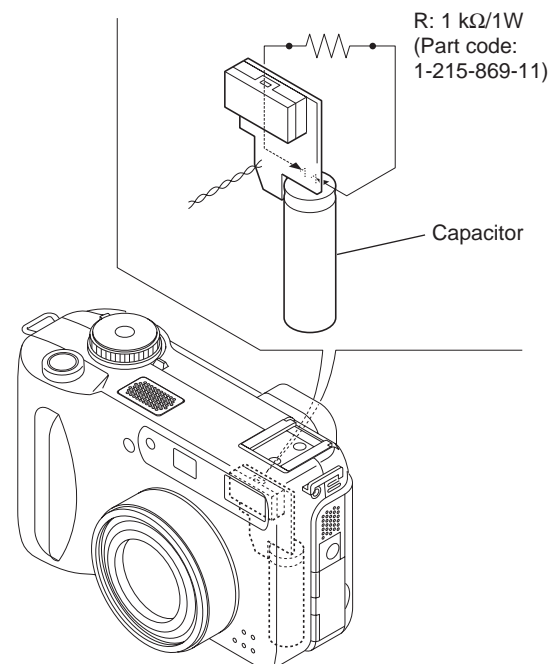

[Description on Self-diagnosis Display]

## Self-diagnosis display

The camera has a self-diagnosis display. This function displays the camera condition with five-digits (a combination of a letter and figures) on the LCD screen. If this occurs check the following code chart. The five-digits display informs you of the camera's current condition. The last two digits (indicated by □□) will differ depending on the state of the camera.

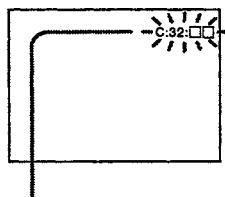

### Self-diagnosis display

- C: □□: □□

You can reverse the camera malfunction yourself. (However, contact your Sony dealer or local authorized Sony service facility when you cannot recover from the camera malfunction.)

- E: □□: □□

Contact your Sony dealer or local authorized Sony service facility.

Display Code	Countermeasure	Cause	Caution Display During Error
C:32:□□	Turn the power off and on again.	Trouble with hardware.	SYSTEM ERROR
C:13:□□	Format the "Memory stick".	Unformatted memory stick is inserted.	FORMAT ERROR
	Insert a new "Memory Stick".	Memory stick is broken.	MEMORY STICK ERROR
E:61:□□	Checking of lens drive circuit.	When failed in the focus and zoom initialization.	—
E:91:□□	Checking of flash unit or replacement of flash unit.	Abnormality when flash is being charged.	

# SECTION 1 GENERAL

This section is extracted from instruction manual.

**WARNING**

To prevent fire or shock hazard, do not expose the unit to rain or moisture.

**For the Customers in the U.S.A.**

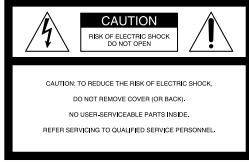

This symbol is intended to alert the user to the presence of uninsulated "dangerous voltage" within the product's enclosure that may be of sufficient magnitude to constitute a risk of electric shock to persons.



This symbol is intended to alert the user to the presence of important operating and maintenance (servicing) instructions in the literature accompanying the appliance.

Never expose the battery pack to temperature above 60°C (140°F), such as in a car parked in the sun or under direct sunlight.

If you have any questions about this product, you may call:  
Sony Customer Information Services Center  
1-800-222-SONY (7669)

The number below is for the FCC related matters only.

**Declaration of Conformity**

Trade Name: SONY  
Model No.: DSC-S75  
Responsible Party: Sony Electronics Inc.  
Address: 680 Kinderkamack Road, Oradell, NJ 07649 USA  
Telephone No.: 201-930-6972

This device complies with Part 15 of the FCC Rules. Operation is subject to the following two conditions: (1) This device may not cause harmful interference, and (2) this device must accept any interference received, including interference that may cause undesired operation.

**CAUTION**

You are cautioned that any changes or modifications not expressly approved in this manual could void your authority to operate this equipment.

**Note:**

This equipment has been tested and found to comply with the limits for a Class B digital device, pursuant to Part 15 of the FCC Rules. These limits are designed to provide reasonable protection against harmful interference in a residential installation. This equipment generates, uses, and can radiate radio frequency energy and, if not installed and used in accordance with the instructions, may cause harmful interference to radio communications. However, there is no guarantee that interference will not occur in a particular installation. If this equipment does cause harmful interference to radio or television reception, which can be determined by turning the equipment off and on, the user is encouraged to try to correct the interference by one or more of the following measures:

- Reorient or relocate the receiving antenna.
- Increase the separation between the equipment and receiver.

- Connect the equipment into an outlet on a circuit different from that to which the receiver is connected.
  - Consult the dealer or an experienced radio/TV technician for help.
- The supplied interface cable must be used with the equipment in order to comply with the limits for a digital device pursuant to Subpart B of Part 15 of FCC Rules.

**For the Customers in the U.S.A.**

**DISPOSAL OF LITHIUM ION BATTERY. LITHIUM ION BATTERY. DISPOSE OF PROPERLY.**

You can return your unwanted lithium ion batteries to your nearest Sony Service Center.

**Note:**

In some areas the disposal of lithium ion batteries in household or business trash may be prohibited.

For the Sony Service Center nearest you call 1-800-222-SONY (United States only)

**Caution:**

Do not handle damaged or leaking lithium ion battery.

**For the Customers in Germany**

Directive: EMC Directive 89/336/EEC, 92/31/EEC

This equipment complies with the EMC regulations when used under the following circumstances:

- Residential area
- Business district
- Light-industry district

(This equipment complies with the EMC standard regulations EN55022 Class B.)

**Attention for the Customers in Europe**

This product has been tested and found compliant with the limits sets out on the EMC Directive for using connection cables shorter than 3 meters.

The electromagnetic fields at the specific frequencies may influence the picture and sound of this camera.

**"Memory Stick" and battery pack**

**For the Customers in the U.S.A.**

This device complies with Part 15 of the FCC Rules. Operation is subject to the following two conditions: (1) This device may not cause harmful interference, and (2) this device must accept any interference received, including interference that may cause undesired operation.

**"Memory Stick"**



**For the Customers in the U.S.A. and Canada**

THIS CLASS B DIGITAL DEVICE COMPLIES WITH PART 15 OF THE FCC RULES AND THE CANADIAN ICES-003 OPERATION IS SUBJECT TO THE FOLLOWING TWO CONDITIONS:  
(1) THIS DEVICE MAY NOT CAUSE HARMFUL INTERFERENCE, AND  
(2) THIS DEVICE MUST ACCEPT ANY INTERFERENCE RECEIVED, INCLUDING INTERFERENCE THAT MAY CAUSE UNDESIRE OPERATION.

**Be sure to read the following before using your camera**

**Trial recording**

Before you record one-time events, you may want to make a trial recording to make sure that the camera is working correctly.

**No compensation for contents of the recording**

Contents of the recording cannot be compensated for if recording or playback is not possible due to a malfunction of your camera or recording medium, etc.

**Notes on image data compatibility**

- This camera conforms with the Design Rules for Camera File Systems universal standard established by the JEITA (Japan Electric and Information Technology Industries). You cannot play back on your camera still images recorded on other equipment (DCR-TRV890E/TRV900/TRV900E, DSC-D700, DSC-D770) that does not conform with this universal standard. (These models are not sold in some areas.)
- Playback of images recorded with your camera on other equipment and playback of images recorded or edited with other equipment on your camera are not guaranteed.

**Precaution on copyright**

Television programs, films, video tapes, and other materials may be copyrighted. Unauthorized recording of such materials may be contrary to the provision of the copyright laws.

**Do not shake or strike the camera**

In addition to malfunctions and inability to record images, this may render the "Memory Stick" unusable or image data breakdown, damage or loss may occur.

**Do not aim the camera at the sun or other bright light**

This may cause irrecoverable damage to your eyes.

**LCD screen, LCD finder (only models with a finder) and lens**

- The LCD screen and the LCD finder are manufactured using extremely high-

precision technology so over 99.99% of the pixels are operational for effective use. However, there may be some tiny black points and/or bright points (white, red, blue or green in color) that constantly appear on the LCD screen and the LCD finder. These points are normal in the manufacturing process and do not affect the recording in any way.

- Be careful when placing the camera near a window or outdoors. Exposing the LCD screen, the finder or the lens to direct sunlight for long periods may cause malfunctions.

**Do not get the camera wet**

When taking pictures outdoors in the rain or under similar conditions, be careful not to get the camera wet. If moisture condensation occurs, refer to page 79 and follow the instructions on how to remove it before using the camera.

**Back up recommendation**

To avoid the potential risk of data loss, always copy (back up) data to a disk.

**Handling of the movable lens**

This camera uses a movable lens. Be careful not to strike or apply excessive force to the lens portion.

**When the camera is used for long periods**

Note that the camera body may become hot.

**About the Carl Zeiss lens**

This camera is equipped with a Carl Zeiss lens which is capable of reproducing fine images. The lens for this camera uses the MTF\* measurement system for cameras developed jointly by Carl Zeiss, in Germany, and Sony Corporation, and offers the same quality as other Carl Zeiss lenses.

\* MTF is the abbreviation of Modulation Transfer Function/Factor, a numeric value indicating the amount of light from a specific part of the subject gathered at the corresponding position in the image.

## Introduction

Checks the image after recording images

- Recording still images: page 19
- Playing back still images: page 28
- Deleting images (DELETE): page 67

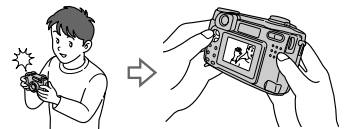

Captures images with your computer

You can copy images onto your computer and view and modify images or attach images to e-mail on your computer using the supplied USB cable and application software.

- Viewing images using a personal computer: page 31
- Recording still images for e-mail (E-MAIL): page 53

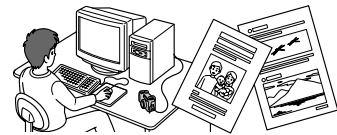

Records a moving picture (MPEG Movie or Clip Motion) according to your purpose

The digital still camera can record a moving picture with audio (MPEG MOVIE): page 26



Selects the recording mode from various types of recordings according to your situation

- Creating Clip Motion Files: page 56
- Adding audio files to still images (VOICE): page 54
- Recording text documents (TEXT): page 55
- Recording still images as uncompressed files (TIFF): page 56

## Identifying the parts

See the pages in parentheses for details of operation.

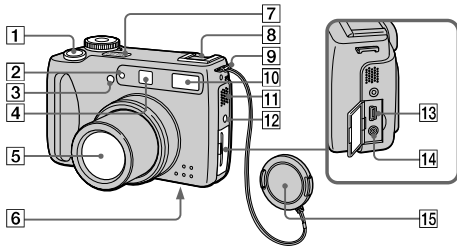

- |  |  |
|--|--|
| <p><b>1 Shutter button (19) (27)</b></p> <p><b>2 Self-timer (23) (27)/ AF illuminator (25)</b></p> <p><b>3 Photocell window for flash</b><br/>Do not block while recording with the flash.</p> <p><b>4 Finder window</b></p> <p><b>5 Lens</b><br/>When cleaning the lens, first return the lens to the fully retracted position and turn off the power, then gently wipe the lens.</p> <p><b>6 Tripod receptacle (bottom surface)</b><br/>Use a tripod with a screw length of less than 5.5 mm (7/32 inch). You will be unable to firmly secure the camera to tripods having longer screws, and may damage the camera.</p> | <p><b>7 Built-in microphone</b><br/>Do not touch while recording.</p> <p><b>8 Accessory shoe</b></p> <p><b>9 Hook for lens cap/strap</b></p> <p><b>10 Flash (24)</b></p> <p><b>11 Speaker</b></p> <p><b>12 ACC (Accessory) jack</b></p> <p><b>13 USB jack (33) (35)</b></p> <p><b>14 A/V OUT jack (66)</b><br/>Audio output is monaural.</p> <p><b>15 Lens cap (supplied)</b><br/>Be sure to remove the lens cap before recording.</p> |
|--|--|

8

## Preparing the power supply

### Installing the battery pack

Your camera operates only with the "InfoLITHIUM" NP-FM50 battery pack\* (M series). You cannot use any other battery pack. See page 81 for more information about "InfoLITHIUM" battery pack.

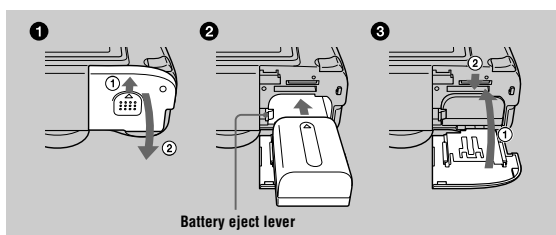

- 1 Open the battery/"Memory Stick" cover.**  
Slide the cover in the direction of the arrow.
- 2 Install the battery pack.**  
Insert the battery pack with the ▲ mark facing toward the battery compartment as illustrated.
- 3 Close the battery/"Memory Stick" cover.**

To remove the battery pack

**Open the battery/"Memory Stick" cover. Slide the battery eject lever downward, and remove the battery pack.**  
Be careful not to drop the battery pack when removing it.

#### \* What is "InfoLITHIUM"?

"InfoLITHIUM" is a lithium ion battery pack which can exchange information such as battery consumption with compatible video equipment. This unit is compatible with the "InfoLITHIUM" battery pack (M series). "InfoLITHIUM" M series battery packs have the mark. "InfoLITHIUM" is a trademark of Sony Corporation.

10

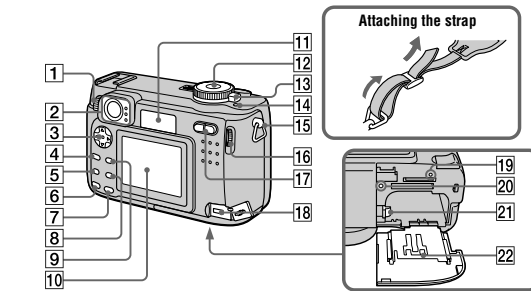

- |  |   |
|--|---|
| <p><b>1 Finder adjustment dial (21)</b></p> <p><b>2 Finder Self-timer/recording lamp (red) AE/AF lock lamp (green) Flash charge lamp (orange) (24)</b></p> <p><b>3 Control button (18) (41)</b></p> <p><b>4 MENU button (41)</b></p> <p><b>5  (Exposure) button (59)</b></p> <p><b>6 FOCUS button (58)</b></p> <p><b>7 AE LOCK button (49)</b></p> <p><b>8  (spot meter) button (62)</b></p> <p><b>9 DSPL/LCD ON/OFF button (23)</b></p> <p><b>10 LCD screen</b></p> <p><b>11 Display window</b></p> <p><b>12 Mode dial (18) (40)</b><br/>  : To record still images, VOICE mode audio data<br/>  : To playback or edit images<br/>  : To record moving images or Clip Motion images</p> | <p><b>13 POWER switch (15)</b></p> <p><b>14 POWER ON/OFF (CHG) lamp (15)</b></p> <p><b>15 Hook for strap</b></p> <p><b>16 Jog dial (42)</b></p> <p><b>17 Zoom button (INDEX button during playback) (22)</b></p> <p><b>18 DC IN jack (11) (14)</b></p> <p><b>19 RESET button (83)</b></p> <p><b>20 Access lamp (17)</b></p> <p><b>21 Battery eject lever (10)</b></p> <p><b>22 Battery/"Memory Stick" cover</b></p> |
|--|---|

SET UP: To set the setup items  
 SCN: To record in the SCENE SELECTION mode  
 M: To record with the manual adjustment  
 A: To record in the aperture priority mode  
 S: To record in the shutter speed priority mode

Getting started

9

### Charging the battery pack

You cannot charge the battery pack while your camera is turned on. Be sure to turn off your camera.

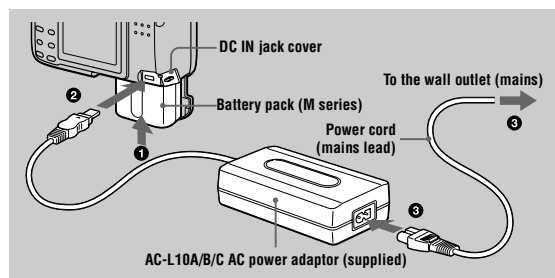

- 1 Insert the battery pack into your camera.**
- 2 Open the DC IN jack cover and connect the DC connecting cable to the DC IN jack of your camera with the ▲ mark facing up.**
- 3 Connect the power cord (mains lead) to the AC power adaptor and then to a wall outlet (mains).**  
The CHARGE lamp in the display window flashes when charging begins. When the CHARGE lamp goes off, charging is completed.

After charging the battery pack

Disconnect the AC power adaptor from the DC IN jack on your camera.

Battery remaining indicator

The LCD screen on the camera shows the remaining time for which you can still record or play back images. This indication may not be entirely accurate depending on the conditions of use and the operating environment. Charging at 10°C to 30°C (50°F to 86°F) circumstances is recommended.

Getting started

11

### NP-FM50 battery pack

When you record images in an extremely cold location or using the LCD screen, the operating time becomes short. When using the camera in an extremely cold location, place the battery pack in your pocket or other place to keep it warm, then insert the battery pack into the camera just before recording. When using a pocket heater, take care not to let the heater directly contact the battery.

#### Charging time

Battery pack	Full charge (min.)
NP-FM50 (supplied)	Approx. 150

Approximate time to charge a completely discharged battery pack using the AC-L10A AC power adaptor at a temperature of 25°C (77°F).

#### Battery life and number of images that can be recorded/played back

##### Still image recording\*

	NP-FM50 (supplied)	
	Battery life (min.)	Number of images
LCD screen ON	Approx. 150	Approx. 2500
LCD screen OFF	Approx. 180	Approx. 3000

##### Still image playback\*\*

	NP-FM50 (supplied)	
	Battery life (min.)	Number of images
LCD screen ON	Approx. 270	Approx. 5000

Approximate battery life and number of images that can be recorded/played back with a fully charged battery pack at a temperature of 25°C (77°F), 640×480 image size, standard picture quality and in NORMAL recording mode.

\* Recording at about 4-second intervals

\*\*Playing back single images in order at about 3-second intervals

##### Moving image recording

	NP-FM50 (supplied)	
	LCD screen OFF (min.)	LCD screen ON (min.)
Continuous recording	Approx. 210	Approx. 180

Approximate recording time with a fully charged battery pack at a temperature of 25°C (77°F) and 160×112 image size.

12

### Using the AC power adaptor

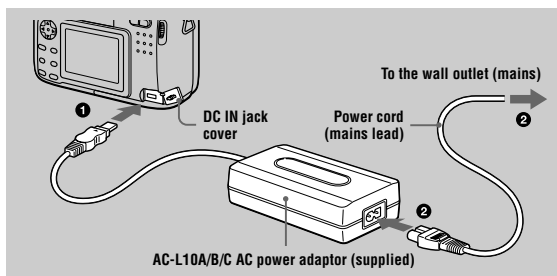

- 1 Open the DC IN jack cover and connect the DC connecting cable to the DC IN jack of your camera with the ▲ mark facing up.
- 2 Connect the power cord (mains lead) to the AC power adaptor and then to a wall outlet (mains).

#### Using a car battery

Use Sony DC adaptor/charger (not supplied).

#### Using your camera abroad

For details, see page 82.

#### When using the AC power adaptor

Be sure to use it near the wall outlet. If a malfunction occurs, disconnect the plug from the wall outlet.

14

### Notes

- The battery life and number of images will be decreased if you use your camera at low temperatures, use the flash, repeatedly turn the power on/off or use the zoom.
- The numbers of images shown on tables above are as a guide. The numbers may be smaller depending on conditions.
- The capacity of the "Memory Stick" is limited. The above figures are a guide when you continuously record/play back while replacing the "Memory Stick."
- "..." appears in the display window until the battery usable time is calculated.
- During charging, the indicators in the display window may not appear correctly or may flash in the following cases.
  - When the battery pack is not installed correctly.
  - When the AC power adaptor is disconnected.
  - When the battery pack has malfunctioned.
- When you turn the LCD screen on and off, it takes about one minute for the correct battery remaining time to appear.
- If sufficient battery remaining time is indicated but the power runs out soon, fully charge the battery so that the correct battery remaining time appears.
- Do not short the DC plug of the AC power adaptor with a metallic object, as this may cause malfunction.

13

### Setting the date and time

When you first use your camera, set the date and time. If these are not set, the CLOCK SET screen appears whenever you turn on your camera.

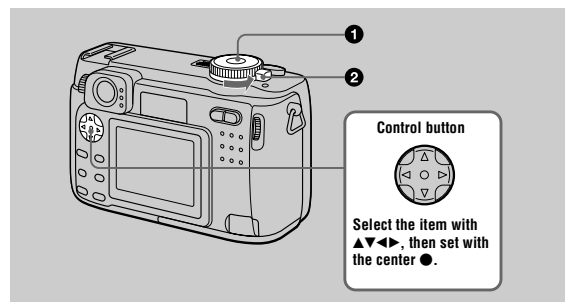

- 1 Set the mode dial to , S, A, M, SCN, , or .
- 2 Slide the POWER switch in the direction of the arrow to turn on the power. The POWER ON/OFF (CHG) lamp (green) lights up. The CLOCK SET screen appears on the LCD screen. To change the date and time, set the mode dial to SET UP (page 77) and perform the procedure from step 3.

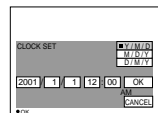

- 3 Select the desired date display format with ▲/▼ on the control button, then press the center ●. Select from [Y/M/D] (year/month/day), [M/D/Y] (month/day/year) or [D/M/Y] (day/month/year).

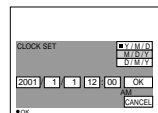

15

- 4** Select the year, month, day, hour or minute item you want to set with **◀/▶** on the control button.

The item to be set is indicated with **▲/▼**.

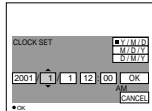

- 5** Set the numeric value with **▲/▼** on the control button, then press the center **●** to enter it.

After entering the number, **▲/▼** moves to the next item.

If you selected [D/M/Y] in step **4**, set the time on a 24-hour cycle.

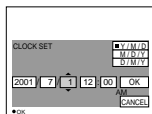

- 6** Select [OK] with **▶** on the control button, then press the center **●** at the desired moment to begin clock movement.

The date and time are entered.

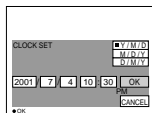

To cancel the date and time setting

Select [CANCEL] with **▲/▼/◀/▶** on the control button, then press the center **●**.

#### Note

If the rechargeable button battery is ever fully discharged (page 80), the CLOCK SET screen will appear again. When this happens, reset the date and time, by starting from step **4** above.

16

Basic operations

▶ Recording

## Basic operations

### How to use the mode dial

The mode dial switches the function which is used for recording, playback, or editing. Set the dial as follows before starting to operate your camera.

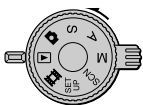

- M:** To record still images, VOICE mode audio data
- A:** To play back or edit images
- S:** To record moving images or Clip Motion images
- SET UP:** To display the setup items (The SET UP position changes the settings of infrequently-used items.)
- M:** To record with the shutter speed and aperture set manually
- A:** To record in the aperture priority mode
- S:** To record in the shutter speed priority mode
- SCN:** To record in the SCENE SELECTION mode (Set in advance the SCENE SELECTION in SET UP screen)

### How to use the control button

When the menu is not displayed, the control button is used to perform the following operations.

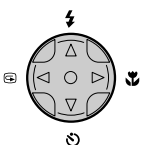

- ⚡ (▲):** Recording with flash
- ⌚ (▼):** Recording with self-timer
- ⏪ (◀):** Checking the last recorded image
- ⏩ (▶):** Recording close subjects

18

## Inserting the "Memory Stick"

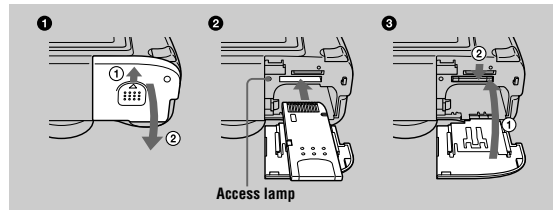

- 1** Open the battery/"Memory Stick" cover. Slide the cover in the direction of the arrow.

- 2** Insert the "Memory Stick." Insert the "Memory Stick" with the **▶** mark facing toward the battery compartment as illustrated until it clicks.

- 3** Close the battery/"Memory Stick" cover.

### Removing the "Memory Stick"

Open the battery/"Memory Stick" cover, then press the "Memory Stick" once lightly.

#### Notes

- Insert the "Memory Stick" firmly until it clicks, otherwise a message such as "MEMORY STICK ERROR" will be displayed.
- Never remove the "Memory Stick" or turn off the power while the access lamp is lit up.
- You cannot record or edit images on a "Memory Stick" if the erasure prevention switch is set to the LOCK position.

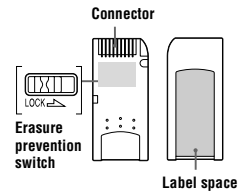

The position and shape of the erasure prevention switch may differ depending on the types of "Memory Stick" used.

Getting started

17

## Recording still images

Still images are recorded in JPEG format.

Before recording still images, slide the POWER switch in the direction of the arrow to turn on the power and insert a "Memory Stick."

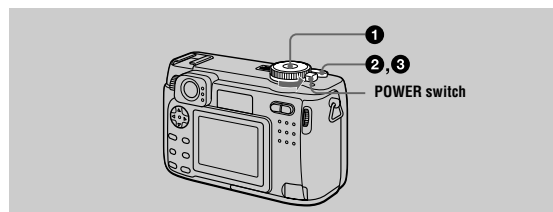

- 1** Set the mode dial to **M, S, A, M** or **SCN**.

- 2** Press and hold the shutter button halfway down. The image freezes momentarily, but is not yet recorded. While the AE/AF lock indicator **●** is flashing, the camera automatically adjusts the exposure and focus of the captured image. When the camera finishes the automatic adjustments, the AE/AF lock indicator **●** stops flashing, then lights up and the camera is ready for recording.\* If you release the shutter button, the recording will be canceled.



AE/AF lock indicator (green) flashes → lights up

▶ Recording

19

### 3 Press the shutter button fully down.

The shutter sounds. "RECORDING" appears on the LCD screen, and the image will be recorded on the "Memory Stick." When "RECORDING" disappears, you can record the next image.

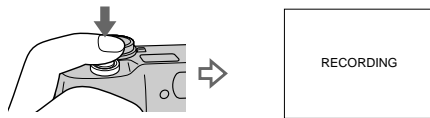

\* If the flashing AE/AF lock indicator changes to flashing slowly, the subject may be difficult to focus on (dark, poor contrast) or the subject may be extremely close. Release the shutter button, then focus again.

#### Auto power-off function

If you do not operate the camera for about three minutes during recording or playback, the camera turns off automatically to prevent wearing down the battery. To use the camera again, slide the POWER switch in the direction of the arrow to turn on the camera again. The auto power-off function only operates when the camera is operating using a battery pack. The auto power-off also will not operate when playing back moving images or playing back a SLIDE SHOW (page 65), or when a connector is plugged into the USB jack, the DC IN jack, or the ACC jack.

The number of images you can record on a "Memory Stick"

See pages 48 and 53 to 57.

#### Notes

- Do not touch the lens portion while it is operating.
- When recording a bright subject, the LCD screen color may change after AE/AF lock, but this does not affect the recorded image.
- When you press the shutter button fully down at once in step 3, the camera starts recording after the automatic adjustment is complete. However, the recording cannot be carried out while the  $\zeta$  flash charge lamp (page 21) is flashing. (During this time, the camera is charging the flash.)

20

### Using the zoom feature

The lens portion moves during zoom operation. Be careful not to touch the lens portion while it is operating.

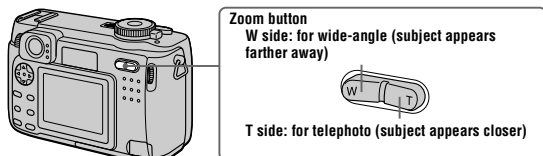

If you cannot get a sharp focus on a close subject

Press the zoom W button repeatedly and move closer to the subject until the focus is sharp.

#### Minimum focal distance to the subject

W side: About 50 cm (19 3/4 inches) or more

T side: About 50 cm (19 3/4 inches) or more

To record even closer subjects, see page 58.

#### Digital zoom function

This camera has a digital zoom function.

Digital zoom enlarges the image by digital processing and it starts to function when zoom exceeds 3x.

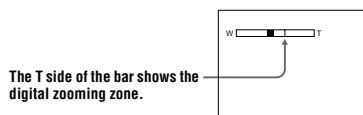

#### Using digital zoom

- The maximum zoom magnification is 6x.
- Digital zooming deteriorates the picture quality. When digital zoom is not necessary, set [DIGITAL ZOOM] to [OFF] in the setup settings (page 76).

#### Notes

- Digital zoom does not work for moving images.
- Use the LCD screen when using the digital zoom function. Digitally zoomed images do not appear in the finder.
- The AF frame (page 94) does not appear on the LCD screen.

22

### Recording images with the finder

You can extend the battery time by turning off the LCD screen and recording using the finder. Turn the finder adjustment dial until the image appears clearly within the finder, then record the image.

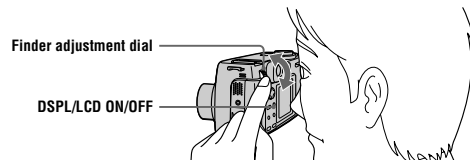

#### Indicators in the finder

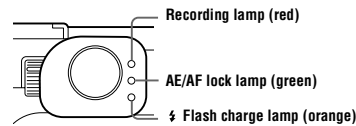

### Checking the last recorded image (Quick Review)

You can check the last recorded image by clearing the menu from the screen (page 41) and pressing  $\blacktriangle$  (M) on the control button.

**To return to the normal recording mode:** press lightly on the shutter button or press  $\blacktriangle$  (M) again.

**To delete the image:** 1. Press MENU. 2. Select [DELETE] with  $\blacktriangleright$  on the control button, then press the center  $\bullet$ . 3. Select [OK] with  $\blacktriangle$  on the control button, then press the center  $\bullet$ .

21

### The indicators on the LCD screen

Each time you press DSPL/LCD ON/OFF, the status of the LCD screen changes as follows:

The LCD backlight is turned on.  
(All the available indicators are turned on.)

The LCD backlight is turned on.  
(Warning messages and manual adjustment items which are set using the jog dial are turned on.)

The LCD backlight is turned off.

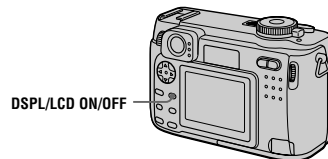

See page 94 for a detailed description of the indicated items.

#### Notes

- Because of the difference of the portion of the finder and the lens, use the LCD screen when you record a subject closer than 1 m (3 1/4 feet).
- You cannot turn off the LCD screen when [DEMO] or [CONVERSION LENS] are set to [ON] in the SET UP settings.
- You cannot turn off the LCD backlight in SET UP and when displaying the menu.
- You cannot turn off the self-timer indicators and some of the indicators used in advanced operations.
- The indicators on the LCD screen are not recorded.

### Using the self-timer

When you use the self-timer function, the subject is recorded about 10 seconds after you press the shutter button.

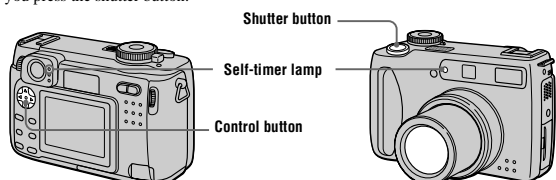

23

Clear the menu (page 41), then press the control button **▼** (⊙). The **⊙** (self-timer) indicator appears on the LCD screen, and about 10 seconds after you press the shutter button, the subject is recorded. The self-timer lamp flashes and the beep sounds after you press the shutter button until the shutter is released. To cancel the self-timer recording, press the control button **▼** (⊙) again.

### Recording images with the flash

The factory setting is auto (no indicator). In this mode, the flash automatically strobos when the surroundings is dark. To change the flash mode, clear the menu (page 41), then press the control button **▲** (⚡) repeatedly so that the flash mode indicator appears on the LCD screen.

Control button **▲** (⚡)

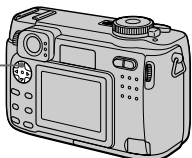

Each time you press the control button **▲** (⚡), the indicator changes as follows.

(No indicator) → ⚡ → ⊕ → (No indicator)

⚡ Forced flash: The flash strobos regardless of the surrounding brightness.

⊕ No flash: The flash does not strobe.

You can change the brightness of the flash with [**±**] (FLASH LEVEL) in the menu settings (page 44).

### To reduce the red-eye phenomenon

Set [RED EYE REDUCTION] to [ON] in the setup settings, the flash strobos before recording to reduce the red-eye phenomenon (page 76). When [ON] is selected, **●** appears on the LCD screen.

### Notes

- When [ISO] is set to [AUTO] in the menu settings, the recommended shooting distance using the built-in flash is 0.3 m to 3.0 m (11 7/8 feet to 9 feet). When it is not set to [AUTO], the flash may be ineffective even if the flash level is changed.
- Attaching a conversion lens (not supplied) may block the light from the flash or cause the lens shadow to appear.
- You cannot use an external flash (not supplied) and the built-in flash at the same time.
- Red-eye reduction may not produce the desired effects depending on individual differences, the distance to the subject, if the subject does not see the pre-strobe, or other conditions.
- Red-eye reduction effects are also difficult to obtain if you set the shutter to a slow speed in the shutter speed priority mode.
- The flash effect is not obtained easily when you use forced flash in a bright location.
- While charging the flash, the ⚡ flash charge lamp flashes. After the charging is complete, the lamp goes out.

24

## Recording moving images

Moving images with audio are recorded in MPEG format (page 39).

To record moving images, slide the POWER switch in the direction of the arrow to turn on the power and insert a "Memory Stick."

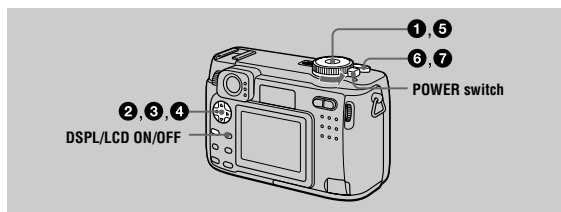

**1** Set the mode dial to **SET UP**.

**2** Select [**📷**] (CAMERA) with **▲/▼** on the control button, then press **▶**.

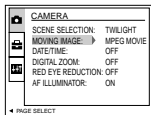

**3** Select [**MOVING IMAGE**] with **▲/▼** on the control button, then press **▶**.

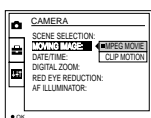

**4** Select [**MPEG MOVIE**] with **▲/▼** on the control button, then press the center **●**.

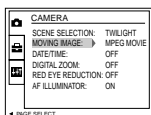

**5** Select the mode dial to **📷**.

26

- The flash does not function when recording moving images (excluding Clip Motion) or recording in BURST2 mode.

### Recording images with the AF illuminator

The AF illuminator is fill light to focus on a subject easily under dark conditions. Set [AF ILLUMINATOR] (page 76) to [ON] in the setup settings, **⦿** appears on the LCD screen and the AF illuminator emits light when the shutter button is pressed halfway. It keeps emitting light until the focus is locked.

AF illuminator

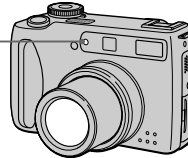

### Notes

- If AF illuminator light does not reach the subject sufficiently or the subject has no contrast, focus will not be achieved. (Approximate 0.3 to 3.0 m (11 7/8 inches to 9 feet 10 1/8 inches) distance is recommended.)
- In TWILIGHT mode of the SCENE SELECTION function (page 51), the AF illuminator will emit only when the flash mode is set to ⚡ (Forced flash).
- The AF illuminator will not emit when the LANDSCAPE mode of the SCENE SELECTION function (page 51) is selected or [CONVERSION LENS] (page 77) is set to [ON] in the setup settings.
- Focus is achieved as long as AF illuminator light reaches to the subject even if its light is slightly out of the middle position of the subject.
- The AF illuminator is a very bright light. Although it is safe to use, avoid shining it directly into someone's eyes at a close distance.
- The AF illuminator does not operate when adjusting focus manually.

25

**6** Press the shutter button fully down.

"REC" appears on the LCD screen, and the image and sound are recorded on the "Memory Stick."

**7** Press the shutter button fully down again to stop recording.

The recording stops.

When selecting the 320 (HQ) size: The recording stops in approximate 15 seconds (page 47).

When selecting the 320×240 or 160×112 sizes: The recording stops when the "Memory Stick" is full.

For details on the image size, see "Setting the image size (IMAGE SIZE)" on page 47."

When [IMAGE SIZE] in the menu setting is set to [320 (HQ)], the maximum recording time is 20 seconds (page 48).

### Using the self-timer

When you use the self-timer function, the subject is recorded about 10 seconds after you press the shutter button.

Clear the menu (page 41), then press the control button **▼** (⊙). The **⊙** (self-timer) indicator appears on the LCD screen, and the recording starts about 10 seconds after you press the shutter button. The self-timer lamp flashes and the beep sounds after you press the shutter button until the shutter is released. To stop the self-timer recording, press the control button **▼** (⊙) again.

### LCD screen indicators during recording

Each time you press DSPL/LCD ON/OFF, the status of the LCD screen changes as follows: all indicators on → indicators off → LCD screen off.

These indicators are not recorded. See page 95 for a detailed description of the indicators.

▶ Recording

▶ Recording

27

## Playing back still images

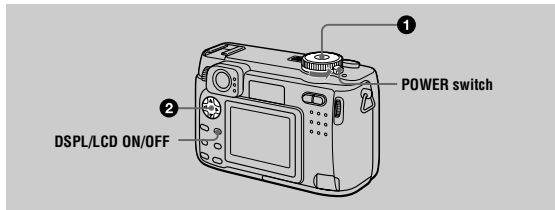

- 1 Set the mode dial to . The last recorded image (still or moving) appears on the LCD screen.

- 2 Select the desired still image with the control button / .
  - ◀: To display the preceding image.
  - ▶: To display the next image.

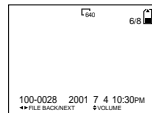

### Notes

- You might not be able to correctly play back images recorded with this camera on other equipment.
- You cannot play back on this camera images larger than the maximum image size that can be recorded with this camera.

### LCD screen indicators during still image playback

Each time you press DSPL/LCD ON/OFF, the status of the LCD screen changes as follows: all indicators on → indicators off → LCD screen off. See page 96 for a detailed description of the indicators.

28

Moving images recorded with the image of [320 (HQ)] (page 47)

The images are displayed over the entire screen in steps 2 and 3.

### Adjusting the volume

Press the control button / to adjust the volume.

### LCD screen indicators during moving image playback

Each time you press DSPL/LCD ON/OFF, the status of the LCD screen changes as follows: all indicators on → indicators off → LCD screen off. See page 96 for a detailed description of the indicators.

30

## Playing back moving images

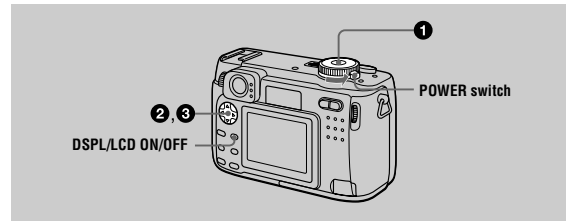

- 1 Set the mode dial to . The last recorded image (still or moving) appears on the LCD screen.

- 2 Select the desired moving image with the control button / . Moving images are displayed one-size smaller than still images.
  - ◀: To display the preceding image.
  - ▶: To display the next image.

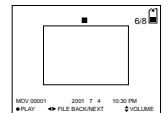

- 3 Select the center to start the playback. The moving image and sound are played back. During playback, (playback) appears on the LCD screen. To advance or rewind, press the control button / during playback.

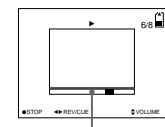

Playback bar

To pause playback

Press the center on the control button to stop the playback.

To advance or rewind the moving image

Press the control button / during playback.

To return to the normal playback, press the center on the control button.

## Viewing images using a personal computer

You can view data recorded with your camera on a personal computer, modify and attach it to e-mail using application software. This section describes the method for viewing images on a personal computer using the supplied USB cable. There are two ways to make the USB connection, which are the normal connection and the PTP connection (page 77). This is set using [USB CONNECT] in the setup settings. However, any OS does not conform to [PTP] as of March, 2001. Here describes the way using the [NORMAL] setting.

The factory setting of USB mode is [NORMAL].

The mode can be checked and set as follows.

- 1 Set the mode dial to SET UP.
- 2 Select [SETUP2] with / , then press .
- 3 Select [USB CONNECT] with / , then press .
- 4 Select the connection mode with / .

The USB cable is used to connect the camera to a personal computer so that operations can be performed on image files recorded in a "Memory Stick" from the personal computer.

In order to use the USB cable, a USB driver must be installed in the personal computer beforehand.

Be sure to also refer to the operation manuals for your personal computer and the application software.

### Notes

- Data recorded with your camera is stored in the following formats. Make sure that applications that support these file formats are installed on your personal computer.
    - Still images (other than TEXT mode, uncompressed mode and Clip Motion): JPEG format
    - Moving images/audio: MPEG format
    - Uncompressed mode still images: TIFF format
    - TEXT mode/Clip Motion: GIF format
  - Depending on your application software, the file size may increase when you open a still image file.
  - When you copy the image to the camera from your computer, which was modified with a retouching software and was converted to another file format, the "FILE ERROR" message may appear and you may be unable to open the image.
  - Depending on your application software, only the first frame of the Clip Motion file may be played back.
- Communications with your computer (for Windows only)  
Communications between your camera and your computer may not recover after recovering from Suspend or Sleep.

31

## Recommended computer environment

### Recommended Windows environment

OS: Microsoft Windows 98, Windows 98SE, Windows 2000 Professional, Windows Millennium Edition

The above OS is required to be installed at the factory.

Operation is not assured in an environment upgraded to the operating systems described above.

CPU: MMX Pentium 200 MHz or faster

The USB connector must be provided as standard.

### Recommended Macintosh environment

Macintosh computer with the Mac OS 8.5.1/8.6/9.0/9.1 standard installation

However, note that the update to Mac OS 9.0/9.1 should be used for the following models.

- iMac with the Mac OS 8.6 factory pre-installed and a slot loading type CD-ROM drive

- iBook or Power Mac G4 with the Mac OS 8.6 factory pre-installed

The USB connector must be provided as standard.

QuickTime 3.0 or newer must be installed (to play back moving pictures).

### Notes

- If you connect two or more USB equipment to a single personal computer at the same time, some equipment may not operate depending on the type of USB equipment.
- Operations are not guaranteed when using a hub.
- Operations are not guaranteed for all the recommended computer environments mentioned above.

• Microsoft and Windows are either registered trademarks or trademarks of Microsoft Corporation in the United States and/or other countries.

• Macintosh and Mac OS, QuickTime are either registered trademarks or trademarks of Apple Computer, Inc.

• All other product names mentioned herein may be the trademarks or registered trademarks of their respective companies. Furthermore, "TM" and "®" are not mentioned in each case in this manual

32

### 7 Follow the on-screen messages to have the Add Hardware Wizard recognize the hardware.

The Add Hardware Wizard starts twice because two different USB drivers are to be installed. Be sure to allow the installation to complete without interrupting it.

### Notes

- Do not connect the USB cable before the USB driver installation is completed in step 4.
- In step 7, make sure that a "Memory Stick" is inserted into your camera before installing the USB driver. Otherwise, you will be unable to install the USB driver.

For Macintosh users

#### • When using MacOS9.1

It is not necessary to install the USB driver. The Macintosh recognizes the camera as a drive simply by connecting it to the Macintosh with the USB cable.

#### • When using MacOS8.5.1/8.6/9.0

Follow the procedures below to install the driver.

- 1 Turn on your personal computer and allow the Mac OS to load.
- 2 Insert the supplied CD-ROM in the CD-ROM drive of your personal computer.
- 3 Double-click the CD-ROM drive icon to open the window.
- 4 Double-click the icon of the hard disk containing the OS to open the window.
- 5 Move the following two files from the window opened in step 3 to the "System Folder" icon in the window opened in step 4 (drag and drop).
  - Sony USB Driver
  - Sony USB Shim
- 6 When "Put these items into the Extensions folder?" appears, click "OK."
- 7 Restart your personal computer.

34

## Installing the USB driver

Before connecting your camera to your personal computer, install the USB driver to the computer. The USB driver is included with the application software in the CD-ROM which is supplied with your camera.

**Be sure to complete installation of the USB driver before connecting the USB cable. If you connect the USB cable first, you will be unable to install the USB driver properly.**

See page 88 for corrective measures if the USB cable was connected before installing the driver and the driver software could not be installed correctly.

For Windows 98/98SE/Me and Windows 2000 users

- 1 Turn on your personal computer and allow Windows to load.  
Do not connect the USB cable in this step.
- 2 Insert the supplied CD-ROM in the CD-ROM drive of your personal computer.  
The application software screen appears.
- 3 Click "USB Driver Installation for Windows 98/98SE/Me and Windows 2000".  
USB driver installation starts.
- 4 Follow the on-screen messages to install the USB driver.  
Your personal computer may restart.
- 5 Connect the USB jack (mini-B) on your camera with the USB connector on your personal computer using the supplied USB cable.

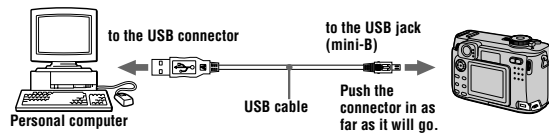

- 6 Insert a "Memory Stick" into your camera, connect the AC power adaptor and turn on your camera.  
"USB MODE" appears on the LCD screen of your camera and the camera is set to communication standby mode. Your personal computer recognizes the camera, and the Windows Add Hardware Wizard starts.

▶ Playback

33

## Viewing images

When viewing moving images on a Windows system, RealPlayer, Windows Media Player or other moving image playback applications must be installed. When viewing moving images on a Macintosh system, QuickTime3.0 or later must be installed.

- 1 Turn on the power of your personal computer and allow Windows or Mac OS to load.
- 2 Connect the USB jack (mini-B) on the camera with the USB connector on your personal computer using the supplied USB cable.

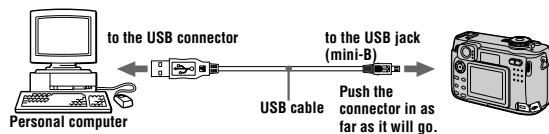

- 3 Insert a "Memory Stick" into your camera, and connect the AC power adaptor to your camera and then to a wall outlet (mains).
- 4 Turn on the power of your camera.  
"USB MODE" appears on the LCD screen of the camera.

▶ Playback

## For Windows 98/98SE/Me and Windows 2000 users

- 5 Open "My Computer" on Windows and double click the newly recognized drive. (Example: "Removable Disk (E:)")  
The folders inside the "Memory Stick" are displayed.  
If the drive is not recognized, see "Troubleshooting" on page 83.

35

**6 Select and double-click the desired image/sound file from the folder.**

For the detailed folder and file name, see "Image file storage destinations and image files" on page 38.

Desired file type	Double-click in this order
Still image	"Dcim" folder → "100msdcf" folder → Image file
Moving image*	"Mssony" folder → "Moml0001" folder → Image file*
Audio*	"Mssony" folder → "Momlv100" folder → Audio file*
Clip Motion image	"Dcim" folder → "100msdcf" folder → Image file
E-mail image TIFF image (uncompressed)	"Mssony" folder → "Imcif100" folder → Image file

\* Copying a file to the hard disk of your personal computer before viewing it is recommended. If you play back the file directly from the "Memory Stick", the image and sound may break off.

**For Macintosh users**

Follow the procedure 1 - 4 on page 35.

**5 Double click the newly recognized icon on the desktop.**  
The folders inside the "Memory Stick" are displayed.

**6 Select and double-click the desired image/sound file from the folder.**

**Notes on using your personal computer**

"Memory Stick"

- Operation is not guaranteed if you are using a "Memory Stick" that was formatted with a personal computer, or if you used a personal computer to format the "Memory Stick" in your camera through a USB connection.
- Do not optimize the "Memory Stick" on a Windows machine. This will shorten the "Memory Stick" life.
- Do not compress the data on the "Memory Stick." Compressed files cannot be played back on your camera.

**Image file storage destinations and image files**

Image files recorded with your camera are grouped in folders by recording mode. The meanings of the file names are as follows. □□□□ stands for any number within the range from 0001 to 9999.

For Windows Me users (The drive recognizing the camera is "E.")

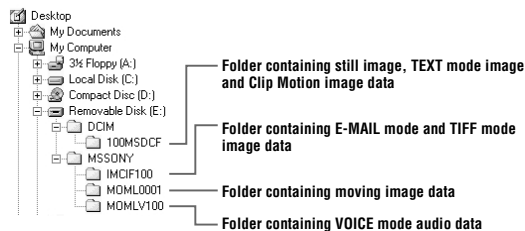

Folder	File	Meaning
100MSDCF	DSC0□□□□.JPG	• Still image file recorded normally • Still image file recorded in – E-MAIL mode (page 53) – TIFF mode (page 56) – VOICE mode (page 54) – Burst mode (page 52)
	CLP0□□□□.GIF	• Clip Motion file recorded in NORMAL mode (page 56)
	CLP0□□□□.THM	• Index image file of Clip Motion file recorded in NORMAL mode
	MBL0□□□□.GIF	• Clip Motion file recorded in MOBILE mode (page 56)
	MBL0□□□□.THM	• Index image file of Clip Motion file recorded in MOBILE mode
	TXT0□□□□.GIF	• Still image file recorded in TEXT mode (page 55)
TXT0□□□□.THM	• Index image file of still image file recorded in TEXT mode	

For Windows Me and Windows 2000 users

The following procedures are recommended when disconnecting the USB cable from your personal computer or ejecting the "Memory Stick" from the camera while it is connected to your personal computer.

- 1 Stop the drive by clicking on the "Unplug/Eject" icon in the task tray.
- 2 When the message appears confirming the safe removal of the hardware, disconnect the USB cable or eject the "Memory Stick".

**Software**

- Depending on your application software, the file size may increase when you open a still image file.
- When you load an image modified using the supplied retouch software from your personal computer to the camera or when you directly modify the image on the camera, the image format will differ so the "FILE ERROR" message may appear and you may be unable to open the file.
- Depending on your application software, only the first frame of the Clip Motion file may be played back.

**Communications with your personal computer (for Windows only)**

Communications between your camera and your personal computer may not recover after recovering from Suspend, Resume, or Sleep.

Folder	File	Meaning
IMCIF100	DSC0□□□□.JPG	• Small-size image file recorded in E-MAIL mode (page 53)
	DSC0□□□□.TIF	• Uncompressed image file recorded in TIFF mode (page 56)
MOML0001	MOV0□□□□.MPG	• Moving image file recorded normally
MOMLV100	DSC0□□□□.MPG	• Audio file recorded in VOICE mode (page 54)

The numerical portions of the following files are the same.

- A small-size image file recorded in E-MAIL mode and its corresponding image file
- An uncompressed image file recorded in TIFF mode and its corresponding image file
- An audio file recorded in VOICE mode and its corresponding image file
- An image file recorded in TEXT mode and its corresponding index image file
- An image file recorded with Clip Motion and its corresponding index image file

**Tips**

The digital still camera saves recorded images as digital data. The format of the saved data is called as the file format. The formats that can be used with this camera are as follows:

**JPEG format**

Most digital still cameras, operating systems of computers, and browser software adopt this format. This format is able to compress files without appreciable deterioration. However, if the image is compressed and saved on repeated occasions, the image will deteriorate. This camera records still images using the JPEG format for normal recording.

**GIF format**

Using this format, the image will not deteriorate even if the image is compressed and saved on repeated occasions. This format limits the number of colors to 256 colors. This camera records still images using the GIF format in Clip Motion (page 56) or TEXT mode (page 55).

**TIFF format**

Stores shooting images without compression, so the image does not deteriorate. Most of operating systems and applications correspond to this format. This camera records still images using the TIFF format for the TIFF mode (page 56).

**MPEG format**

This format is very typical for moving images. This camera records audio using the MPEG format for the moving images recording and the VOICE mode (page 54).

## Before performing advanced operations

This section describes the basic control methods that are frequently used for "Advanced operations."

### How to use the mode dial

The mode dial switches the function which is used for recording, playback, or editing. Set the dial as follows before starting to operate your camera.

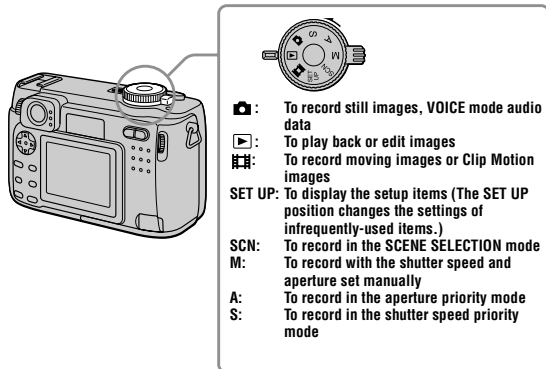

**📷:** To record still images, VOICE mode audio data

**▶:** To play back or edit images

**🎞️:** To record moving images or Clip Motion images

**SET UP:** To display the setup items (The SET UP position changes the settings of infrequently-used items.)

**SCN:** To record in the SCENE SELECTION mode

**M:** To record with the shutter speed and aperture set manually

**A:** To record in the aperture priority mode

**S:** To record in the shutter speed priority mode

**2** When the mode dial is set to SET UP or ▶:

- Press ▲/▼/◀/▶ on the control button to select the item you want to set up.
- Press the center ● on the control button to enter the item.

**When the mode dial is set to 📷, S, A, M, SCN, or 🎞️:**

Press ▲/▼/◀/▶ on the control button to select the setting of the item. The selected setting is turned to yellow, and the setup is complete.

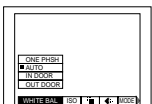

### How to use the jog dial

The functions which are used frequently in recording are set up using the jog dial and the following direct buttons. The jog dial is used to change the value in manual adjustments.

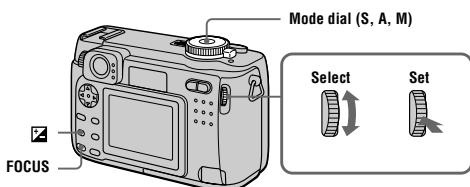

Mode dial (S, A, M)

Select

Set

FOCUS

- 1** Set the mode dial to S, A, or M. The adjustable value number appears at the right corner on the LCD.

### How to use the control button

When the menu or setup screen is displayed, the control button is used to select the buttons, images and menu items displayed on the LCD screen of your camera and modify the settings. The operation methods that are frequently used for "Advanced operations" are described below.

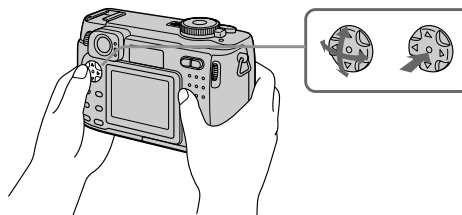

### Turning on/off the operation buttons (menu) on the LCD screen

Press MENU to display/clear the menu on the LCD screen.



Menu

### Setting up the items in the setup or menu

**1** Set the mode dial to SET UP so that the setup screen appears, or press MENU so that the menu appears.

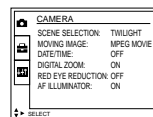

**2** Turn the jog dial to select the item or value number you want to adjust.

- When the indication ◀ at the right corner on the LCD screen is in yellow, you can select the item. In such cases, go to step 3.
- When the value number at the right corner on the LCD screen is in yellow, you can adjust the value. (When you press FOCUS, the Ⓢ mark appears on value number position.)

When you adjust only the value, the adjustment is complete.

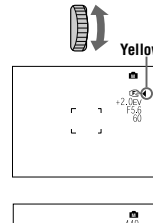

**3** Press the jog dial. The value number turns to yellow. To adjust the value, repeat step 2.

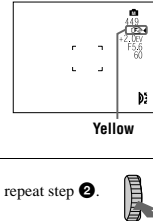

### Viewing the next/previous image using the jog dial during playback

When viewing an image in single-image mode (page 63), you can easily view the next/previous image by turning the jog dial.

### Menu settings

Menu items that can be modified differ depending on the positions of the mode dial. The LCD screen shows only the items you can operate at the moment. Factory settings are indicated with ■.

When the mode dial is set to /SCN/S/A/M

Item	Setting	Description
WB (WHITE BAL.)	ONE PUSH ■ AUTO IN DOOR OUT DOOR	Sets the white balance (page 60).
ISO	400 200 100 ■ AUTO	Selects the ISO film speed. When recording under dark situations or recording a fast-moving subject, use a high-number setting. When you record high-quality images, use a low-number setting (except when the mode dial is set to SCN).
(IMAGE SIZE)	■ 20481 536 2048 (3:2) 16001 200 12809 60 64048 0	Selects the image size when recording still images.
(P. QUALITY)	■ FINE  STANDARD	Records still images in the fine image quality mode.  Records still images in the standard image quality mode.
MODE (REC MODE)	TIFF  TEXT VOICE  E-MAIL  BURST2 ■ NORMAL	Records a TIFF (uncompressed) file in addition to the JPEG file (page 56).  Records a GIF file in black-and-white (page 55).  Records an audio file (with a still image) in addition to the JPEG file (page 54).  Records a small-size (3200240) JPEG file in addition to the selected image size (page 53).  Records two images continuously (page 52).  Records an image using the normal recording mode.
(FLASH LEVEL)	HIGH ■ NORMAL LOW	Makes the flash level higher than normal. Normal setting Makes the flash level lower than normal.

44

Item	Setting	Description
PFX (P. EFFECT)	SOLARIZE B&W SEPIA NEG.ART ■ OFF	Sets the image special effects (page 61).
(SHARPNESS)	+2 +1 ■ 0 -1 -2	Adjusts the sharpness of the image. The  indicator appears (except when the setting is 0).

When the mode dial is set to

Item	Setting	Description
DELETE	OK CANCEL	Deletes the displayed image (page 67). Cancels deleting of the image.
PROTECT	-	Protects images against accidental erasure (page 68).
PRINT	-	Marks the print mark on still images (page 72).
SLIDE*	INTERVAL  REPEAT START CANCEL	Sets the slide show interval. ■ 3 sec/5 sec/10 sec/30 sec/1 min ■ ON/OFF Starts the slide show. Cancels the slide show.
COPY	OK CANCEL	Copies an image (page 71). Cancels copying of the image.
RESIZE*	2048×1536 1600×1200 1280×960 640×480 CANCEL	Changes the recorded image size (page 70).
ROTATE*	 OK CANCEL	Rotates the still image (page 66).
DIVIDE	OK CANCEL	Divides an moving image (page 74).

\* Only in single-image mode.

46

Item	Setting	Description
PFX (P. EFFECT)	SOLARIZE B&W SEPIA NEG.ART ■ OFF	Sets the image special effects (page 61).
(SHARPNESS)	+2 +1 ■ 0 -1 -2	Adjusts the sharpness of the image. The  indicator appears (except when the setting is 0).

When the mode dial is set to (MOVING IMAGE is set to MPEG MOVIE in the setup settings.)

Item	Setting	Description
WB (WHITE BAL.)	ONE PUSH ■ AUTO IN DOOR OUT DOOR	Sets the white balance (page 60).
(IMAGE SIZE)	320 (HQ) 3202 40 ■ 1601 12	Selects the MPEG image size when recording moving images (page 47).
PFX (P. EFFECT)	SOLARIZE B&W SEPIA NEG.ART ■ OFF	Sets the image special effects (page 61).

When the mode dial is set to (MOVING IMAGE is set to CLIP MOTION in the setup settings.)

Item	Setting	Description
WB (WHITE BAL.)	ONE PUSH ■ AUTO IN DOOR OUT DOOR	Sets the white balance (page 60).
(IMAGE SIZE)	■ NORMAL MOBILE	Selects the Clip Motion image size (page 56).
(FLASH LEVEL)	HIGH ■ NORMAL LOW	Makes the flash level higher than normal. Normal setting. Makes the flash level lower than normal.

### Setting the image size (IMAGE SIZE)

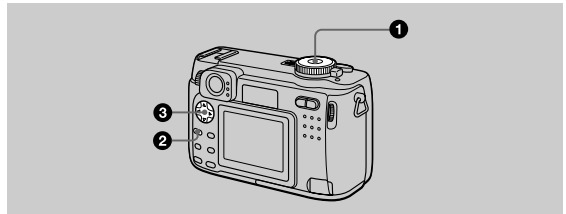

- 1 Set the mode dial to , SCN, S, A, M, or .
- 2 Press MENU. The menu appears.
- 3 Select the desired image size from (IMAGE SIZE) and press .

#### Still image sizes:

2048×1536, 2048 (3:2)\*, 1600×1200, 1280×960, 640×480

\* The image is recorded in the ratio of three to two to fit the printing paper size. Using this image size, the margin of an image is not printed out. However, the slight amount of the upper and lower black portions are displayed on the LCD screen.

#### Moving image (MPEG movie) sizes:

320 (HQ)\*, 320×240, 160×112

\* High Quality mode

#### Clip Motion sizes:

NORMAL (160×120), MOBILE (80×72)

47

The number of images\* or the time\*\* that you can record on a "Memory Stick"

Image size	Quality		Moving image
	STANDARD	FINE	
2048×1536	Approx. 9	Approx. 5	—
2048 (3:2)	Approx. 9	Approx. 5	—
1600×1200	Approx. 15	Approx. 8	—
1280×960	Approx. 22	Approx. 12	—
640×480	Approx. 118	Approx. 48	—
320 (HQ)	—	—	Approx. 20 sec.
320×240	—	—	Approx. 80 sec.
160×112	—	—	Approx. 320 sec.
MOBILE (80×72)	—	—	Approx. 350
NORMAL (160×120)***	—	—	Approx. 40

\* When MODE (REC MODE) is set to NORMAL.  
 \*\* The maximum recording time in continuous recording.  
 \*\*\* When recording 10 frames per Clip Motion file.

**Remaining number of recordable images (page 94)**

The remaining number of recordable images is a guideline for when MODE (REC MODE) is set to NORMAL. The actual number of remaining images may differ depending on the recording conditions.

**Tips**

The size of the image is indicated by the pixel unit. The higher the number of pixels, the more information is included. So, an image that is saved using a large number of pixels is suitable for a large-format print and one that is saved using a smaller number of pixels is suitable for attaching to an E-mail. Normally, an image is recorded in the ratio of four to three to fit the monitor ratio. This camera can also record the image in the ratio of three to two to accommodate the most common printing paper size. This is the same ratio as the one used in photo-developing shops.

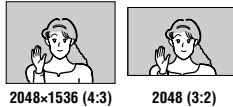

**Recording with the manual adjustments**

Mode dial: S/A/M

**Shutter speed priority mode**

Once the shutter speed is adjusted manually, the aperture will be automatically adjusted to the suitable value to attain correct exposure according to the brightness of the subject. Using the higher shutter speed, you can record a fast-moving subject with its motion frozen. And using the lower shutter speed, you can record the flow motion of a moving subject.

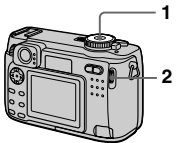

- 1 Set the mode dial to S.
- 2 Select a shutter speed with the jog dial, then press the jog dial.  
The shutter speed can be selected from 8" to 1/1000.

**Aperture priority mode**

Once the aperture is adjusted manually, the shutter speed will be automatically adjusted to the suitable value to attain correct exposure according to the brightness of the subject. Selecting a lower aperture value opens the lens iris. Using a lower aperture value, you can record a subject with its background unclear. And using a higher aperture value, you can record both the subject and the background stand out clearly.

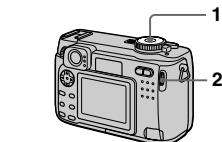

- 1 Set the mode dial to A.
- 2 Select an aperture value with the jog dial, then press the jog dial.  
The aperture value can be selected from F2 to F8.

**Manual exposure mode**

You can manually adjust the shutter speed and aperture values to achieve the desired shooting condition according to your purpose. The exposure value appears on the LCD screen (page 59). And you can also adjust the aperture value and the shutter speed value according to your taste. 0 EV is the most suitable value set by the camera.

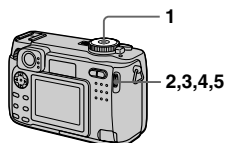

- 1 Set the mode dial to M.
- 2 Select the aperture value indication with the jog dial, then press the jog dial.



**Various recording**

**Recording with the exposure fixed (AE LOCK)**

Mode dial: S/A/M/SCN

Once you press AE LOCK, the exposure, now captured, is fixed. For instance, this function is convenient in the following use:  
 Measure the exposure of the desired portion of the subject using the spot light-metering function and fix its exposure value by pressing AE LOCK. Then, recompose the picture.



- 1 Set the mode dial to S, A, M or SCN.
- 2 Target the subject that has desired exposure value, then press AE LOCK.  
The exposure is fixed and the AE-L mark appears.
- 3 Target the subject you want to record and press and hold the shutter button halfway down.  
The focus is automatically adjusted.
- 4 Press down the shutter button.

To release AE LOCK

Carry out one of the followings:

- Press AE LOCK again after step 2.
- Release your finger from the shutter button after step 3.
- Press down the shutter button in step 4.

Various recording

- 3 Select the aperture value with the jog dial, then press the jog dial.
- 4 Select the shutter speed value indication with the jog dial, then press the jog dial.
- 5 Select the shutter speed value with the jog dial, then press the jog dial.  
For details on available values, see "Shutter speed priority mode" on page 50, or "Aperture priority mode" on page 50.

**Note**

If the setting is not appropriate in aperture priority mode, shutter speed priority mode, or manual exposure mode, the setting value indicator on the LCD screen flashes. You can record in this setting, we, however, recommend that you adjust the flashed-value again.

**Records images according to shooting conditions (SCENE SELECTION)**

Mode dial: SCN

This camera has preset three SCENE SELECTION modes. Each mode is suitable for the following situations; night scene, landscape, and portrait.

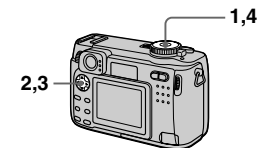

- 1 Set the mode dial to SET UP.  
The setup screen appears.
- 2 Select (CAMERA) with , [SCENE SELECTION] with , then press .
- 3 Select the desired setting, then press .
  - TWILIGHT mode**  
Allows you to record bright subjects in dark places without losing the dark atmosphere of the surroundings. The shutter speed becomes slower, so we recommend that you use a tripod to prevent shaking.
  - LANDSCAPE mode**  
Focuses only on a distant subject to record landscapes, etc.
  - PORTRAIT mode**  
Suits for portrait recordings. Backgrounds blurred away, and the frontward person is sharpened.
- 4 Set the mode dial to SCN.  
The selected setting is loaded.

Various recording

To cancel the SCENE SELECTION function Set the mode dial to , S, A, M, or .

**Notes**

- You can focus only on distant subjects in LANDSCAPE mode.
- Set the forced flash when you use the flash in the following modes:
  - TWILIGHT mode
  - LANDSCAPE mode
- When using the SCENE SELECTION mode, the AF illuminator (page 25) does not emit in the following conditions:
  - TWILIGHT mode: when the flash mode is not set to the forced flash mode
  - LANDSCAPE mode: you cannot use the AF illuminator.

**Tips**

Under normal recording conditions, the camera automatically makes various adjustments, such as those for the focus, iris, exposure, and white balance, as it shoots. However, you may not be able to carry out your desired shooting depending on shooting conditions. The SCENE SELECTION function provides you with near-optimum adjustments to suit your shooting situation.

**Recording two images continuously**

**Mode dial:** /S/A/M/SCN

This mode is used for a continuous recording.

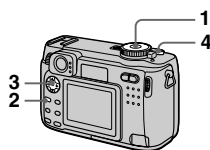

- Set the mode dial to , S, A, M or SCN.
- Press MENU. The menu appears.
- Select [MODE] (REC MODE) with , [BURST2] with .
- Record the image.

To return to normal recording mode Select [NORMAL] with in step 3.

**Notes**

- You cannot use the flash in this mode.
- During recording in this mode, the image is not displayed on the LCD screen. Make the composition before pressing the shutter button.
- The recording interval is approximately 0.6 second.
- You cannot select a shutter speed slower than 1" when recording two images continuously.

**Recording still images for e-mail (E-MAIL)**

**Mode dial:** /S/A/M/SCN

In the E-MAIL mode, a small-size image which is suitable for e-mail transmission is also recorded at the same time as recording a normal still image. (The size of the normal still image is set using (IMAGE SIZE) in the menu settings (page 47).)

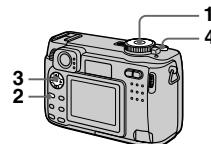

- Set the mode dial to , S, A, M or SCN.
- Press MENU. The menu appears.
- Select [MODE] (REC MODE) with , [E-MAIL] with .
- Record the image.

The number of images that you can record on a "Memory Stick" (8 MB) in E-MAIL mode

Image size	Quality	
	STD	FINE
2048×1536	Approx. 8	Approx. 4
2048 (3:2)	Approx. 8	Approx. 4
1600×1200	Approx. 14	Approx. 8
1280×960	Approx. 21	Approx. 12
640×480	Approx. 95	Approx. 43

**Remaining number of recordable images (page 94)**

The actual number of remaining images may differ depending on the recording conditions.

To return to normal recording mode Select [NORMAL] with in step 3.

**Adding audio files to still images (VOICE)**

**Mode dial:** /S/A/M/SCN

In the VOICE mode, the audio is also recorded at the same time as recording a still image. You can vividly record the situation with audio.

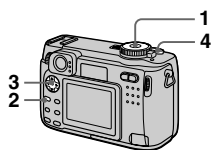

- Set the mode dial to , S, A, M or SCN.
- Press MENU. The menu appears.
- Select [MODE] (REC MODE) with , [VOICE] with .
- Record the image. If you press and release the shutter button, sound is recorded for five seconds. If you hold down the shutter button, sound is recorded until you release the shutter button for up to 40 seconds.

The number of images that you can record on a "Memory Stick" (8 MB) in VOICE mode\*

Image size	Quality	
	STD	FINE
2048×1536	Approx. 8	Approx. 4
2048 (3:2)	Approx. 8	Approx. 4
1600×1200	Approx. 13	Approx. 7
1280×960	Approx. 19	Approx. 11
640×480	Approx. 56	Approx. 34

\* When recording 5-second audio.

To return to normal recording mode Select [NORMAL] with in step 3.

**Recording text documents (TEXT)**

**Mode dial:**

The TEXT mode is suitable for recording a document to emphasize its character by the black and white colors. The LCD screen also turns to black and white, and the image is recorded in the GIF format.

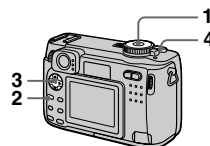

- Set the mode dial to .
- Press MENU. The menu appears.
- Select [MODE] (REC MODE) with , [TEXT] with .
- Record the image.

The number of images that you can record on a "Memory Stick" (8 MB) in TEXT mode\*

Image size	Number of images
2048×1536	Minimum 14
2048 (3:2)	Minimum 16
1600×1200	Minimum 24
1280×960	Minimum 36
640×480	Minimum 121

\* The maximum number of recordable images depends on the document condition, such as the amount of text portions.

To return to normal recording mode Select [NORMAL] with in step 3.

**Notes**

- If the subject is not evenly illuminated, you may be unable to record a clear image.
- Writing and reading data take more time than normal recording.
- When the mode dial is set to S, A, M, or SCN images can be recorded, but the image may be bleached out or may be turned black.
- Remaining number of recordable images is not displayed.
- The number of recordable images is the same regardless of whether (P. QUALITY) is set to STANDARD or FINE.

## Recording still images as uncompressed files (TIFF)

Mode dial: / S / A / M / SCN

Records the images without compression, so the image does not deteriorate. Images recorded in this mode are suitable for printing with a high-quality image. The JPEG (compressed) format image is also recorded with the TIFF format image.



- 1 Set the mode dial to , S, A, M or SCN.
- 2 Press MENU. The menu appears.
- 3 Select [MODE] (REC MODE) with , [TIFF] with .
- 4 Record the image. The number of images that you can record on a "Memory Stick" (16 MB) in TIFF mode is approx. 1.

To return to normal recording mode

Select [NORMAL] with in step 3.

### Notes

- JPEG images are recorded in the image size selected by the [ ] (IMAGE SIZE) menu (page 47). TIFF images are recorded in [2048×1536] size other than when [2048 (3:2)] is selected.
- Writing data takes more time than in normal recording.
- The supplied "Memory Stick" (8 MB) does not have sufficient capacity to record uncompressed images.

56

## Creating Clip Motion Files

Mode dial:

Clip Motion is an animation function that plays back still images in succession. The images are stored in GIF format, which is convenient for creating home pages or attaching images to an e-mail.

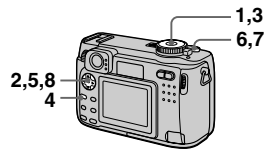

- 1 Set the mode dial to SET UP. The setup screen appears.
- 2 Select [ ] (CAMERA) with , [MOVING IMAGE] with , [CLIP MOTION] with , then press .
- 3 Set the mode dial to .
- 4 Press MENU. The menu appears.
- 5 Select [ ] (IMAGE SIZE) with , the desired mode with .

### NORMAL (160×120)

Clip Motion of up to 10 frames can be recorded. This is suitable for use on home pages, etc.

### MOBILE (80×72)

Clip Motion of up to 2 frames can be recorded. This is suitable for use with portable data terminals.

- 6 Record the image for the first frame.

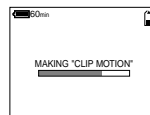

Before carrying out step 8, the images are temporarily stored in memory. These images are not recorded on the "Memory Stick", yet.

- 7 Record the image for the next frame.

Image recording can be repeated up to the maximum number of recordable frames.

- 8 Press .

All the frame images are recorded on the "Memory Stick".

To delete some or all the frame images while making a Clip Motion recording

- ① Press the control button in step 6 or 7. The recorded frame images are played back in turn and stop at the last image.
- ② Press MENU, and select [DELETE LAST] or [DELETE ALL], then press .
- ③ Select [OK], then press . When [DELETE LAST] is selected in step ②, each time you repeat step ③, the recorded frame is deleted from the newest one.

The number of Clip Motion frames that you can record on a "Memory Stick" (8 MB)

Image size	Number of images
NORMAL (160×120)	Approx. 40*
MOBILE (80×72)	Approx. 350

\* When recording 10 frames per Clip Motion file

### Notes

- You cannot change the image size partway through a Clip Motion recording.
- Reading and writing data take more time than normal image recording.
- Due to the limitations of the GIF format, the number of colors for Clip Motion images is reduced to 256 colors or less. Therefore, the picture quality may deteriorate for some images.
- The file size is reduced in MOBILE mode, so the picture quality deteriorates.
- GIF files not created on this camera may not be displayed correctly.
- All the frame images are immediately recorded on the "Memory Stick" if the mode dial is switched or the power is turned off.

▶ Various recording

57

## Setting the distance to the subject

Mode dial: / S / A / M / SCN /

Normally the focus is automatically adjusted. This function is useful when the auto focus does not work well such as in dark places.



- 1 Set the mode dial to , S, A, M, SCN or .
- 2 Press FOCUS. The focus is fixed and the (manual focus) indicator appears.
- 3 Turn the jog dial to select the desired focus setting. You can select from 15 focus settings (unit: m) including the position: 0.1, 0.2, 0.3, 0.5, 0.8, 1.0, 1.5, 2, 3, 5, 7, 10, 15, and ∞ (infinity)

To reactivate auto focusing

Press FOCUS again and the focal point information disappears.

### Notes

- Focal point information may not completely show the correct distance. Use the information as a guide.
- The focus preset cannot be set when attaching a conversion lens.
- Focusing error increases if the lens is pointed up or down.
- If you shoot a subject within 0.5 m (19 3/4 inches) while the zoom is set to the T side, you cannot get a clear focus. In such cases, the focal point information flashes. Press the zoom W button until the indicator stops flashing.

58

## Recording images in macro

Mode dial: / S / A / M / SCN /

The macro recording is used when zooming up a little subject, such as flowers, insects.



- 1 Set the mode dial to , S, A, M, SCN or .
- 2 Clear the menu, and press the control button ( ). The (macro) indicator appears on the LCD screen. You can record a subject as close as about 4 cm (1 5/8 inches) from the lens surface with the zoom set all the way to the W side, or about 20 cm (8 inches) with the zoom set all the way to the T side.

To return to normal recording mode

Press the control button ( ) again. The indicator disappears.

### Notes

- You cannot record images in macro with the LANDSCAPE mode of the SCENE SELECTION function.
- When recording images in macro, use the LCD screen. If you record using the finder, the range visible in the finder may differ from the actual recording range.

## Adjusting the exposure (EXPOSURE)

Mode dial: / S / A / SCN /

Adjusts the exposure value which is set in the automatic adjustment.

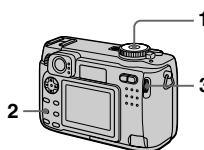

- 1 Set the mode dial to , S, A, SCN or .
- 2 Press .
- 3 Select the desired exposure value with the jog dial. Adjust the exposure value while checking the brightness of the background. You can select values ranging from +2.0 EV to -2.0 EV in steps of 1/3 EV.

### Note

If a subject is under extremely bright or dark situations, or the flash is used, the exposure adjustment may not be effective.

### Tips

Normally, the camera automatically adjusts the exposure. If the color of the image is too dark or bright as illustrated below, we recommend that you adjust the exposure manually. When recording a backlit subject or a subject in the snow, set it toward +, and when recording a dark subject with fully displayed on the LCD screen, set it toward -.

Set the exposure toward +



Set the exposure toward -

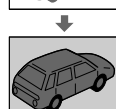
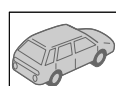

▶ Various recording

59

## Adjusting the white balance (WHITE BALANCE)

Mode dial: / S / A / M / SCN /

Normally, the white balance is automatically adjusted (AUTO). When you record with the shooting condition fixed or under the specific lighting condition, you can manually adjust the white balance.

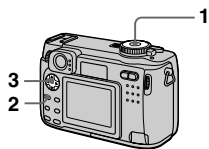

- 1 Set the mode dial to , S, A, M, SCN or .
- 2 Press MENU. The menu appears.
- 3 Select [WB] (WHITE BAL) with / , the desired setting with / .

### ONE PUSH ()

Adjusting the white balance depending on the light source

### AUTO (No indicator)

Adjusts the white balance automatically  
Under fluorescent lighting

### IN DOOR ()

- Places where the lighting condition changes quickly
- Under bright lighting such as photography studios
- Under sodium or mercury lamps

### OUT DOOR ()

Recording a sunrise/sunset, night scene, neon signs, or fireworks

60

## Notes

- If you select [DATE] in step 3, the date is imposed onto the image in the order selected with "Setting the date and time" (page 15).
- The date and time are not superimposed onto moving images or Clip Motion images.

To shoot in one-push white balance mode

- 1 Select [ONE PUSH]. The indicator appears.
- 2 Shoot a white object such as paper full under the same situation you will shoot.
- 3 Press . The indicator flashes quickly. When the white balance has been adjusted and stored in the memory, the indicator stops flashing.

To reactivate auto adjustment  
Select [AUTO] with / in step 3.

## Notes

- The indicator means:  
Slow flashing: white balance is not set or was not able to be set.  
Quick flashing: white balance is being adjusted (after you pressed ).  
Lit steady: white balance has been set.
- If the indicator keeps flashing even when you press , record in automatic white balance mode.

## Tips

The image is susceptible to lighting conditions. The image looks blue under sunlight in the summer, and looks red under mercury lamps. Human eyes can resolve these problems. However, the camera cannot resolve the problem without making adjustments. Normally, the camera adjusts it automatically, but, if the image appears in strange colors, we recommend that you change the white balance mode.



## Notes

- If you select [DATE] in step 3, the date is imposed onto the image in the order selected with "Setting the date and time" (page 15).
- The date and time are not superimposed onto moving images or Clip Motion images.

## Using the spot light-metering function

Mode dial: / S / A / M / SCN /

Use this function when there is backlight or when there is strong contrast between the subject and the background, etc. Position the point you want to record on the spot light-metering cross hair.



Press to activate the spot light-metering function.  
Position the point you want to record at the spot light-metering cross hair.  
Record the picture when the automatic adjustment has been completed.

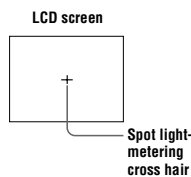

62

## Enjoying picture effects (P. EFFECT)

Mode dial: / S / A / M / SCN /

You can digitally process images to obtain special effect.

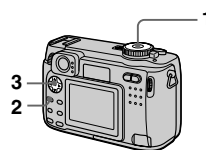

- 1 Set the mode dial to , S, A, M, SCN or .
- 2 Press MENU. The menu appears.
- 3 Select [PFX] (P. EFFECT) with / , the desired mode with / .

### SOLARIZE

The light contrast is clearer and the picture looks like an illustration.

### B&W

The picture is monochrome (black and white).

### SEPIA

The picture is sepia-toned like an old photograph.

### NEG.ART

The color and brightness of the picture are reversed as in a negative.

### OFF

Does not use the picture effect function.

To cancel picture effect  
Select [OFF] with / in step 3.

## Recording the date and time on the still image (DATE/TIME)

Mode dial: / S / A / M / SCN

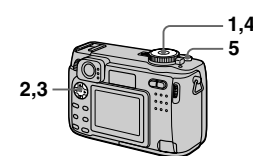

- 1 Set the mode dial to SET UP. The setup screen appears.
- 2 Select [] (CAMERA) with / , [DATE/TIME] with / , then press .
- 3 Select the date and time setting with / , then press .
  - DAY & TIME  
Imposes the date, hour, and minute.
  - DATE  
Imposes the year, month, and day.
  - OFF  
Does not impose the date and time.
- 4 Set the mode dial to , S, A, M, or SCN.
- 5 Record the image. The date and time do not appear on the LCD screen during shooting. These appear during playback only.



Various recording

61

## Various playback

### Playing back three or nine images at once

Mode dial:

You can display multiple images on the LCD screen at one time using the zoom buttons.

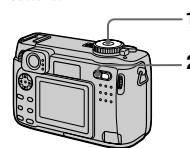

- 1 Set the mode dial to .
- 2 Press the zoom W button repeatedly. The LCD screen display changes as follows:
  - Single (single-image) screen

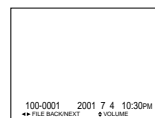

- Index (nine-image) screen

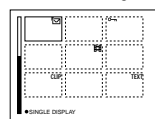

- Triple-image screen

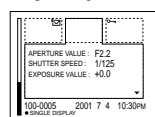

The image indicated by the yellow frame in the index screen is displayed in the middle of the triple-image screen with the recording information. To display the other information, press the control button / / / .

The following marks are displayed on each image according to the image type and settings.

- : Moving image file
- : VOICE mode file
- : E-mail file
- : Print mark
- : Protect mark
- TEXT: TEXT file
- TIFF: TIFF file
- CLIP: Clip Motion file
- (No mark): Normal recording (no settings)

To display the next (previous) index screen  
Press the control button / / / .

To return to normal playback (single-image)  
• Press the zoom T button repeatedly.  
• Press the control button .

## Note

When viewing an image recorded in Clip Motion or TEXT mode on the index screen, the image may appear different from the actual image.

## Tips

When the triple-image screen is displayed, pressing MENU opens the menu including [PRINT], [PROTECT], and [DELETE]. For details on these items, see pages 67, 68, or 72. To close the menu, press MENU again. The menu disappears and the recording information is indicated.

Various playback

63

## Enlarging a part of the still image (Zoom and trimming)

Mode dial:

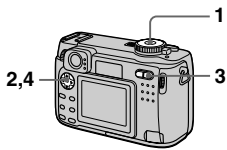

- 1 Set the mode dial to .
- 2 Display the image to be enlarged.
- 3 Zoom in/out the image with the zoom T/W buttons.
- 4 Press the control button repeatedly to select the desired portion of the image.
  - ▲: The image moves downward
  - ▼: The image moves upward
  - ◀: The image moves rightward
  - ▶: The image moves leftward

To return to the normal size  
Press the control button .

To record an enlarged image (trimming)

- 1 Press MENU after zooming.
- 2 Select [TRIMMING] with , then press .
- 3 Select the image size with , , then press . The image is recorded and the image on the LCD screen returns to the normal size after recording.

### Notes

- You cannot zoom moving images.
- You can zoom images recorded in TEXT mode, but cannot trim them.
- Zoom scaling is up to 5× regardless of the original image size.
- The quality of enlarged images may be deteriorated.
- The original data is left even if you enlarge the image.
- The enlarged image is recorded as the newest file.
- If you trim an image, the remaining "Memory Stick" capacity will be decreased.
- If the remaining "Memory Stick" capacity is not sufficient, you may be unable to trim an image.
- You cannot trim to an image of 3:2.

## Playing back the still images in order (SLIDE)

Mode dial:

This function is useful for checking the recorded images or for presentations, etc.

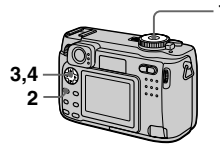

- 1 Set the mode dial to .
- 2 Press MENU. The menu appears.
- 3 Select [SLIDE], then press . Set the following items.

### INTERVAL

You can select from 1 min (one minute), 30 sec (30 seconds), 10 sec (10 seconds), 5 sec (5 seconds), or 3 sec (3 seconds).

### REPEAT

ON: Plays back images in a continuous loop.  
OFF: After all images have been played back, the slide show ends.

- 4 Select [START], then press . The slide show begins.

To cancel the SLIDE SHOW setting

Select [CANCEL] with , in step 3, then press .

To stop the SLIDE SHOW

playback  
Press , select [EXIT] with , then press .

To skip to the next/previous image during the SLIDE SHOW

Select , at the lower-left on the LCD screen, then press .

### Note

The interval setting time may vary depending on the image size.

64

65

## Rotating a still image (ROTATE)

Mode dial:

You can rotate the image recorded in portrait orientation and display it in landscape orientation.

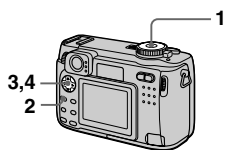

- 1 Set the mode dial to , and display the image to rotate.
- 2 Press MENU. The menu appears.
- 3 Select [ROTATE] with , then press .
- 4 Rotate the image clockwise or counterclockwise , select [OK] with , , then press .

To cancel rotation

Select [CANCEL] with , in step 4, then press .

### Notes

- You cannot rotate protected or uncompressed images, or images recorded in TEXT mode.
- You may not be able to rotate images recorded with other equipment.
- Also, when viewing images on a computer, the image rotation information may not be reflected depending on the application software.

## Viewing images on a TV screen

Mode dial:

Before connecting your camera, be sure to turn off the TV.

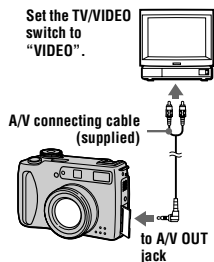

- 1 Connect the A/V connecting cable to the A/V OUT jack of your camera and to the audio/video input jacks of the TV.

If your TV has stereo type input jacks, connect the audio plug (black) of the A/V connecting cable to the Lch jack.

- 2 Turn on the TV and start playback on your camera. The playback image appears on the TV screen.

### Notes

- You cannot use a TV that has an antenna (aerial) connector only.
- When viewing a still image on the TV, the black band may appear around the image.

## ▶ Editing

### Deleting images (DELETE)

Mode dial:

You can delete unwanted files.

#### In single-image or triple-image mode

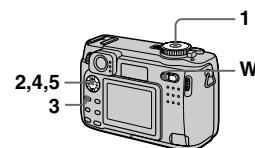

- 1 Set the mode dial to .
- 2 In single-image mode: Display the image you want to delete with , . In triple-image mode: Press the zoom W button twice to turn to the triple-image mode. Display the image you want to delete with , .
- 3 Press MENU. The menu appears.
- 4 Select [DELETE] with , in single-image mode, or with , in triple-image mode, then press .
- 5 Select [OK] with , , then press . The image (or the middle-positioned image in triple-image mode) is deleted.

#### In index mode

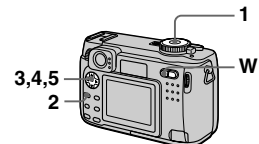

- 1 Set the mode dial to , then display the index screen with the zoom W button.
- 2 Press MENU. The menu appears.
- 3 Select [DELETE] with , , then press .
- 4 Select [ALL] or [SELECT] with , , then press .
- 5 When you select [ALL] Select [ENTER] with , , then press . All the unprotected images are deleted.

#### When you select [SELECT]

- 1 Select the images to be deleted with the control button, then press . To cancel, press again. Repeat this step to select other images. The (delete) indicator appears on the selected images.

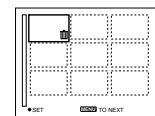

- 2 Press MENU.
- 3 Select [OK] with , , then press .

66

67

To cancel deleting  
Select [CANCEL] with ◀▶ in step 4  
or [EXIT] with ◀▶ in step 5, then  
press ●.

**Note**

If there are files on the "Memory Stick" with names having the same last 4 digits as the file name of the image to be deleted, these files are also deleted at the same time.

**Preventing accidental erasure (PROTECT)**

Mode dial: ▶

Protects images against accidental erasure.

**In single-image or triple-image mode**

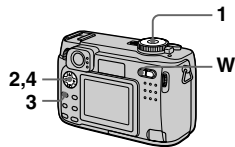

- 1 Set the mode dial to ▶.
- 2 In single-image mode  
Display the image you want to protect with ◀▶.
- In triple-image mode  
Press the zoom W button twice to turn to the triple-image mode. Display the image you want to protect with ◀▶.
- 3 Press MENU.  
The menu appears.
- 4 Select [PROTECT] with ◀▶ in single-image mode, or with ▲▼ in triple-image mode, then press ●.  
The displayed image (or the middle-positioned image in triple-image mode) is protected. The ○ indicator appears on the image.

To release protection  
Press ● again in step 4. ○ indicator disappears.

**In index mode**

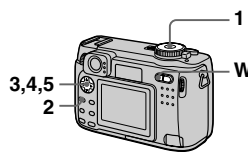

- 1 Set the mode dial to ▶, then display the index screen with the zoom W button.
- 2 Press MENU.  
The menu appears.
- 3 Select [PROTECT] with ◀▶, then press ●.
- 4 Select [ALL] or [SELECT] with ◀▶, then press ●.
- 5 When you select [ALL]  
Select [ON] with ◀▶, then press ●.  
All the images in the "Memory Stick" are protected.
- When you select [SELECT]  
The frame of the selected image turns green.
  - ① Select the images to be protected with the control button, then press ●.  
To cancel, press ● again. Repeat this step to select other images.  
The ○ indicator appears on the selected images.

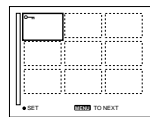

- ② Press MENU.
- ③ Select [OK] with ◀▶, then press ●.

To release protection  
If you selected [ALL] in step 4, select [OFF] then press ●. If you selected [SELECT] in step 4, select the images to be unprotected with the control button. Select [OK] with ◀▶, then press ●.

To cancel protection  
Select [CANCEL] with ◀▶ in step 4 or [EXIT] with ◀▶ in step 5, then press ●.

**Changing the recorded still image size (RESIZE)**

Mode dial: ▶

You can change the image size of the recorded image.

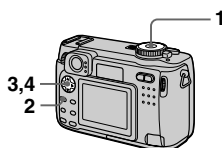

- 1 Set the mode dial to ▶, then display the image of which you want to change the size.
- 2 Press MENU.  
The menu appears.
- 3 Select [RESIZE] with ◀▶, then press ●.
- 4 Select the desired size with ▲▼, then press ●.  
2048×1536, 1600×1200,  
1280×960, 640×480  
The resized image is recorded.

To cancel changing the size  
Select [CANCEL] with ▲▼ in step 4, then press ●.

**Notes**

- The original image is retained even after resizing.
- You cannot change the size of images recorded in TEXT mode, moving images, uncompressed images, or Clip Motion images.
- The resized image is recorded as the newest file.
- If you resize an image, the remaining "Memory Stick" capacity will be decreased.
- When you change from a small size to a large size, the picture quality deteriorates.
- If the remaining "Memory Stick" capacity is not sufficient, you may not be able to resize an image.
- You cannot resize to an image of 3:2.

**Copying images (COPY)**

Mode dial: ▶

You can copy images to another "Memory Stick."

**In single mode**

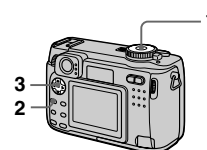

- 1 Set the mode dial to ▶, then display the image which you want to copy.
- 2 Press MENU.  
The menu appears.
- 3 Select [COPY] with ◀▶, [OK] with ▲▼, then press ●.  
"MEMORY STICK ACCESS" appears.
- 4 When "CHANGE MEMORY STICK" appears, eject the "Memory Stick."  
"INSERT MEMORY STICK" appears.
- 5 Insert the "Memory Stick" on which to copy the image.  
"RECORDING" appears. When copying is completed, "COMPLETE" appears.  
To end copying, select [EXIT] with ◀▶, then press ●.

To copy the image to another "Memory Stick"  
Select [CONTINUE] with ▲▼, press ●, then repeat steps 4 and 5.

**In INDEX mode**

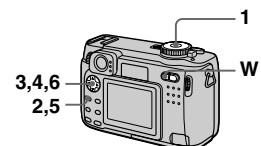

- 1 Set the mode dial to ▶, then display the index screen with the zoom W button.
- 2 Press MENU.  
The menu appears.
- 3 Select [COPY] with ◀▶, [Select] with ▲▼, then press ●.  
The frame of the selected image turns green.
- 4 Select the image to copy with the control button, then press ●.  
To cancel, press ● again. Repeat this step to select other images.  
The ✓ (select) indicator appears on the image.

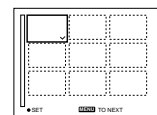

- 5 Press MENU.  
The menu appears.
- 6 Select [ENTER] with ◀▶, then press ●.  
"MEMORY STICK ACCESS" appears.

**7** When “CHANGE MEMORY STICK” is displayed, eject the “Memory Stick.” “INSERT MEMORY STICK” appears.

**8** Insert another “Memory Stick.” “RECORDING” appears. When copying is completed, “COMPLETE” appears. To end copying, select [EXIT] with ▲/▼, then press ●.

To copy the image to another “Memory Stick” Select [CONTINUE] with ▲/▼, press ●, then repeat steps 7 and 8.

To cancel copying part-way Select [CANCEL] with ◀/▶ in step 3 or [EXIT] with ◀/▶ in step 6, then press ●.

**Notes**

- If you do not select [EXIT] after “COMPLETE” appears and instead insert a new “Memory Stick,” the same image copied again.
- You cannot copy uncompressed images.
- You cannot copy images that are bigger than 5 MB at once. If “NOT ENOUGH MEMORY” appears or ✓ flashes on the INDEX screen, cancel some images to copy and try again.

**Selecting still images to print (PRINT)**

**Mode dial:** ▶

You can mark a print mark on still images recorded with your camera. This mark is convenient when you have images printed at a shop that conforms with the DPOF (Digital Print Order Format) standard.

**In single-image or triple-image mode**

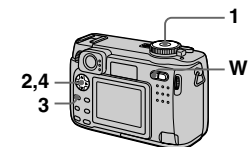

- 1 Set the mode dial to ▶.**
- 2 In single-image mode** Display the image you want to print with ◀/▶.  
**In triple-image mode** Press the zoom W button twice to turn to the triple-image mode. Display the image you want to print with ◀/▶.
- 3 Press MENU.** The menu appears.
- 4 Select [PRINT] with ◀/▶ in single-image mode, or with ▲/▼ in triple-image mode, then press ●.** The (print) mark is marked on the displayed image (or the middle-positioned image in triple-image mode).

To unmark the print mark Press ● again in step 4. mark disappears.

**In index mode**

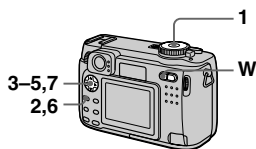

- 1 Set the mode dial to ▶, then display the index screen with the zoom W button.**
- 2 Press MENU.** The menu appears.
- 3 Select [PRINT] with ◀/▶, then press ●.**
- 4 Select [SELECT] with ◀/▶, then press ●.** When marking the mark, you cannot select [ALL]. The frame of the selected image turns green.
- 5 Select the images to be marked with the control button, then press ●.** To cancel, press ● again. Repeat this step to select other images. The mark appears on the selected image.

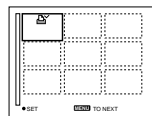

- 6 Press MENU.** The menu appears.
- 7 Select [OK] with ◀/▶, then press ●.**

To unmark selected print marks Select the images to be unmarked in step 5 with the control button, then press ●.

To unmark all the print marks Select [ALL] with ◀/▶ in step 4, then press ●. Select [OFF] with ◀/▶, then press ●. The marks on all images are unmarked.

To cancel marking the print mark Select [CANCEL] with ◀/▶ in step 4 or select [EXIT] with ◀/▶ in step 7, then press ●.

**Notes**

- You cannot mark moving images, Clip Motion images or images recorded in TEXT mode.
- If you mark an image recorded in TIFF mode with a print mark, only the uncompressed image is printed, and the JPEG image recorded at the same time is not printed.
- In E-mail mode, a print mark is marked on the normal size image that is recorded at the same time.

▶ Editing

**Dividing a moving image file (DIVIDE)**

**Mode dial:** ▶

You can divide moving images recorded in MPEG MOVIE mode. This is convenient when there is not enough space on a “Memory Stick” or when attaching moving images to e-mails.

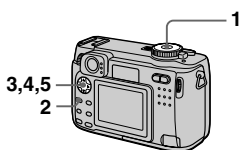

- 1 Set the mode dial to ▶ and display the moving image you want to divide.**
- 2 Press MENU.** The menu appears.
- 3 Select [DIVIDE] with ◀/▶, then press ●, select [OK] with ▲/▼, then press ●.**
- 4 Play the moving image.** If you press ● at this time, ◀II, II▶ (frame forward, frame reverse), [CANCEL] and [EXIT] appear on the screen. If you select [◀II, II▶], you can finely adjust the divide location using ◀/▶. If you select [CANCEL], moving image playback restarts and you can reselect the divide location.
- 5 When you have decided the divide point, select [OK] then press ●.**
- 6 [OK], [CANCEL] and [EXIT] appear on the screen. Select [OK], then press ●.** The moving image file is divided.

You cannot divide the following types of files:

- Clip Motion files
- Still image files
- Moving image files that are too short to divide

The file number changes as follows when you divide a file.  
<eg.> If you divide the MOV0003.mpg file, the divided file numbers become MOV0004.mpg and MOV0005.mpg, and MOV0003.mpg is skipped. The divided files are saved as the latest files.

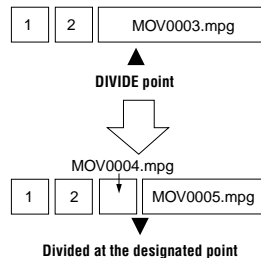

To cancel file division Press [EXIT]. The image playback screen appears.

- To delete unwanted portions
- ① Display the portion of the moving image you want to delete and press MENU.
  - ② Select [DELETE] with ◀/▶, then press ●.
  - ③ Select [OK] with ▲/▼, then press ●.

**Step 1: Divide the unwanted scene A.**

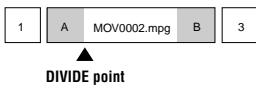

**Step 2: Divide the unwanted scene B.**

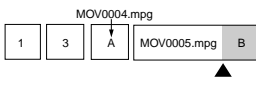

**Step 3: Delete the unwanted scenes A and B.**

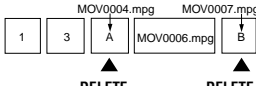

**Step 4: Only the desired scene remains.**



- Notes**
- You cannot divide Clip Motion files.
  - You cannot recombine divided files.
  - The original undivided file is not saved.

▶ Editing

## Changing the setup settings (SETUP)

Set the mode dial to SET UP. The setup screen appears. You can set up the following items with the control button.

### CAMERA

Item	Setting	Description
SCENE SELECTION	<input checked="" type="checkbox"/> TWILIGHT <input type="checkbox"/> LANDSCAPE <input type="checkbox"/> PORTRAIT	Selects the SCENE SELECTION mode that is assigned to the SCN position (page 51).
MOVING IMAGE	<input checked="" type="checkbox"/> MPEG MOVIE <input type="checkbox"/> CLIP MOTION	Records the MPEG movie (pages 26, 56). Records the Clip Motion.
DATE/TIME	<input type="checkbox"/> DAY & TIME <input type="checkbox"/> DATE <input checked="" type="checkbox"/> OFF	Sets whether to insert the date and time into the image (page 61).
DIGITAL ZOOM	<input checked="" type="checkbox"/> ON <input type="checkbox"/> OFF	Uses digital zoom (page 22). Does not use digital zoom.
RED EYE REDUCTION	<input type="checkbox"/> ON <input checked="" type="checkbox"/> OFF	Reduces the red-eye phenomenon (page 24).
AF ILLUMINATOR	<input checked="" type="checkbox"/> ON <input type="checkbox"/> OFF	Uses when it is hard to focus on the subject under dark situations (page 25).

### SETUP 1

Item	Setting	Description
FORMAT	OK  CANCEL	Formats a "Memory Stick". Note that formatting erases all the information recorded on a "Memory Stick", including even erasure protected images (page 91). Cancels formatting of a "Memory Stick".
FILE NUMBER	<input checked="" type="checkbox"/> SERIES  RESET	Assigns numbers to files in sequence even if the "Memory Stick" is changed. Resets the file numbering each time the "Memory Stick" is changed.

76

Item	Setting	Description
DEMO	<input checked="" type="checkbox"/> ON/STBY <input type="checkbox"/> OFF	Displayed only when you use the AC power adaptor. [DEMO] is set to [STBY] at the factory and the demonstration starts about 10 minutes after you have set the mode dial to  , S, A, or M. To cancel the demonstration, turn off the power. The demonstration will not start if the MOVING IMAGE setting is CLIP MOTION.

#### Notes on [DATE/TIME]

- The date and time do not appear on the LCD screen during shooting. These appear during playback.
- The date and time are not superimposed onto moving images and Clip Motion images.

78

Item	Setting	Description
CONVERSION LENS	<input type="checkbox"/> ON  <input checked="" type="checkbox"/> OFF	Set to "ON" when using the VCL-MHG07 conversion lens (not supplied). At this time, the zoom function does not work and you cannot turn off the LCD screen. Also, note that the VAD-S70 adaptor ring needed to mount the conversion lens to your camera is not sold in some countries and regions.
言語/ LANGUAGE	<input checked="" type="checkbox"/> ENGLISH <input type="checkbox"/> 日本語/JPN	Displays the menu items in English. Displays the menu items in Japanese.
CLOCK SET	<input type="checkbox"/> OK <input type="checkbox"/> CANCEL	Sets the date and time (Perform the procedure from step  on page 15).

### SETUP 2

Item	Setting	Description
LCD BRIGHTNESS	<input type="checkbox"/> BRIGHT <input checked="" type="checkbox"/> NORMAL <input type="checkbox"/> DARK	Selects the LCD brightness. This has no effect on the recorded images.
LCD BACKLIGHT	<input type="checkbox"/> BRIGHT <input checked="" type="checkbox"/> NORMAL	Selects the brightness of the LCD backlight. Lets you set the brightness of the LCD backlight to [BRIGHT] or [NORMAL]. Selecting [BRIGHT] makes the screen bright and easy to see when using the camera outdoors or in other bright locations, but also uses up the battery charge faster.
BEEP	<input type="checkbox"/> SHUTTER  <input checked="" type="checkbox"/> ON  <input type="checkbox"/> OFF	Turns on the shutter sound only. (The shutter sound is heard when you press the shutter button.) Turns on the beep/shutter sound (when you press the control button/shutter button). Turns off the beep/shutter sound.
VIDEO OUT	<input type="checkbox"/> NTSC  <input type="checkbox"/> PAL	Sets the video output signal to NTSC mode (e.g., Japan, the USA) (page 82). Sets the video output signal to PAL mode (e.g., Europe) (page 82).
USB CONNECT	<input type="checkbox"/> PTP <input checked="" type="checkbox"/> NORMAL	Switches the USB mode (page 31).

77

### Additional information

#### Precautions

##### On cleaning

##### Cleaning the LCD screen

Wipe the screen surface with a cleaning cloth (not supplied) or a LCD cleaning kit (not supplied) to remove fingerprints, dust, etc.

##### Cleaning the camera surface

Clean the camera surface with a soft cloth slightly moistened with water, then wipe the surface dry. Do not use any type of solvent such as thinner, alcohol or benzene as this may damage the finish or the casing.

##### After using your camera at the seashore or other dusty locations

Clean your camera carefully. Otherwise, the salty air may corrode the metal fittings or dust may enter the inside of your camera, causing a malfunction.

##### Note on operating temperature

Your camera is designed for use between the temperatures of 0°C and 40°C (32°F and 104°F). Recording in extremely cold or hot places that exceed this range is not recommended.

##### On moisture condensation

If the camera is brought directly from a cold to a warm location, or is placed in a very damp room, moisture may condense inside or outside the camera. Should this occur, the camera will not operate properly.

##### Moisture condensation occurs easily when:

- The camera is brought from a cold location such as a ski slope into a warmly heated room.
- The camera is taken from an air-conditioned room or car interior to the hot outdoors, etc.

#### How to prevent moisture condensation

When bringing the camera from a cold place to a warm place, seal the camera in a plastic bag and allow it to adapt to conditions at the new location over a period of time (about an hour).

##### If moisture condensation occurs

Turn off the camera and wait about an hour for the moisture to evaporate. Note that if you attempt to record with moisture remaining inside the lens, you will be unable to record clear images.

##### On AC power adaptor

- Unplug the unit from the wall outlet (mains) when you are not using the unit for a long time.
- To disconnect the power cord (mains lead), pull it out by the plug. Never pull the power cord (mains lead) itself.
- Do not operate the unit with a damaged cord (mains lead) or if the unit has been dropped or damaged.
- Do not bend the power cord (mains lead) forcibly, or place a heavy object on it. This will damage the cord (mains lead) and may cause fire or electrical shock.
- Prevent metallic objects from coming into contact with the metal parts of the connecting section. If this happens, a short may occur and the unit may be damaged.
- Always keep metal contacts clean.
- Do not disassemble the unit.
- Do not apply mechanical shock or drop the unit.
- While the unit is in use, particularly during charging, keep it away from AM receivers and video equipment. AM reception and video operation are disturbed.
- The unit becomes warm during use. This is not a malfunction.
- Do not place the unit in locations that are:
  - Extremely hot or cold
  - Dusty or dirty
  - Very humid
  - Vibrating

▶ Editing

Additional Information

79

## On battery pack

- Use only the specified charger with the charging function.
- To prevent accident from a short circuit, do not allow metal objects to come into contact with the battery terminals.
- Keep the battery pack away from fire.
- Never expose the battery pack to temperatures above 60°C (140°F), such as in a car parked in the sun or under direct sunlight.
- Keep the battery pack dry.
- Do not expose the battery pack to any mechanical shock.
- Do not disassemble nor modify the battery pack.
- Install the battery pack to the camera securely.
- Charging while some capacity remains does not affect the original battery capacity.

If any problem occurs, unplug your camera and contact your nearest Sony dealer.

## On internal rechargeable button battery

This camera has an internal rechargeable button battery for maintaining the date and time and other settings regardless of whether the power is on or off. This rechargeable button battery is constantly charged as long as you are using the camera. However, if you use the camera for only short periods it discharges gradually, and if you do not use the camera at all for about one month it becomes completely discharged. In this case, be sure to charge this rechargeable button battery before using the camera. However, even if this rechargeable button battery is not charged, you can still use the camera as long as you do not record the date and time.

### Charging method

Connect the camera to a wall outlet (mains) with the AC power adaptor, or install a charged battery pack, and leave the camera for 24 hours or more with the POWER switch set to OFF.

## On "Memory Sticks"

"Memory Stick" is a new compact, portable and versatile IC recording medium with a data capacity that exceeds a floppy disk. "Memory Stick" is especially designed for exchanging and sharing digital data among "Memory Stick" compatible products. Because it is removable, "Memory Stick" can also be used for external data storage.

There are two types of "Memory Sticks": general "Memory Sticks" and "MagicGate Memory Sticks" that are equipped with the MagicGate® copyright protection technology. You can use both types of "Memory Stick" with your camera. However, because your camera does not support the MagicGate standards, data recorded with your camera is not subject to MagicGate copyright protection.

\* MagicGate is copyright protection technology that uses encryption technology.

### Notes

- Do not remove the "Memory Stick" while reading or writing data.
- Data may be damaged if:
  - you remove the "Memory Stick" or turn off your camera while reading or writing data.
  - you use the "Memory Stick" in a location subject to the effects of static electricity or noise.
- Do not attach any other material than the supplied label on the labeling position.
- Attach the label so that it does not stick out from the proper attachment location.
- When you carry or store the "Memory Stick," put it in its supplied case.
- Do not touch the terminals of a "Memory Stick" with your hand or a metal object.
- Do not strike, bend or drop the "Memory Stick."
- Do not disassemble or modify the "Memory Stick."
- Do not allow the "Memory Stick" to get wet.

### SECAM system

Bulgaria, Czech Republic, France, Guiana, Hungary, Iran, Iraq, Monaco, Poland, Russia, Slovak Republic, Ukraine, etc.

## Using your camera abroad

### Power sources

You can use your camera in any country or area with the supplied battery charger within 100 V to 240 V AC, 50/60 Hz. Use a commercially available AC plug adaptor [a], if necessary, depending on the design of the wall outlet (mains) [b].

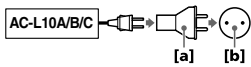

### Watching the playback picture on TV

If you want to view the playback picture on a TV, you need a TV having a video input jack and a video connecting cable.

The color system of the TV must be the same as that of your digital still camera. Check the following list:

### NTSC system

Bahama Islands, Bolivia, Canada, Central America, Chile, Columbia, Ecuador, Jamaica, Japan, Korea, Mexico, Peru, Surinam, Taiwan, the Philippines, the U.S.A., Venezuela, etc.

### PAL system

Australia, Austria, Belgium, China, Denmark, Finland, Germany, Great Britain, Holland, Hong Kong, Italy, Kuwait, Malaysia, New Zealand, Norway, Portugal, Singapore, Spain, Sweden, Switzerland, Thailand, etc.

### PAL-M system

Brazil

### PAL-N system

Argentina, Paraguay, Uruguay

"Memory Stick", "MagicGate Memory Stick" and are trademarks of Sony Corporation.

"MagicGate" and **MAGICGATE** are trademarks of Sony Corporation.

## About "InfoLITHIUM" battery pack

### What is the "InfoLITHIUM" battery pack?

The "InfoLITHIUM" battery pack is a lithium-ion battery pack that has functions for communicating information related to operating conditions between your camera and the AC power adaptor. The "InfoLITHIUM" battery pack calculates the power consumption according to the operating conditions of your camera, and displays the remaining battery time in minutes.

### Charging the battery pack

- Be sure to charge the battery pack before you start using your camera.
- We recommend charging the battery pack in an ambient temperature of between 10°C to 30°C (50°F to 86°F) until the POWER ON/OFF (CHG) lamp goes out, indicating that the battery pack is fully charged. If you charge the battery pack outside of this temperature range, you may not be able to efficiently charge the battery pack.
- After charging is completed, disconnect the AC power adaptor from the DC IN jack on your camera or remove the battery pack.

### Effective use of the battery pack

- Battery performance decreases in low-temperature surroundings. So, the time that the battery pack can be used is shorter in cold places. We recommend the following to use the battery pack longer:
  - Put the battery pack in a pocket close to your body to warm it up, and insert it in your camera immediately before you start taking shots.
- Frequently using the LCD panel or frequently operating the zoom wears out the battery pack faster.

- Be certain to turn the POWER switch to off when not taking shots or playing back on your camera.
- We recommend having spare batteries handy for two or three times the expected shooting time, and make a trial shots before taking the actual shots.
- Do not expose the battery pack to water. The battery pack is not water-resistant.

### Remaining battery time indicator

- If the power goes off although the battery remaining indicator indicates that the battery pack has enough power to operate, charge the battery pack fully again so that the indication on the battery remaining indicator is correct. Note, however, that the correct battery indication sometimes will not be restored if it is used in high temperatures for a long time or left in a fully charged state, or the battery pack is frequently used. Regard the remaining battery time indication as the approximate shooting time.
- The mark indicating there is little remaining battery time sometimes flashes depending on the operating conditions or ambient temperature and environment even if the remaining battery time is 5 to 10 minutes.

### How to store the battery pack

- Even if the battery pack is not used for a long time, store it in a dry, cool place after fully charging it once per year and then using the battery pack up on your camera. This is to maintain the battery pack's functions.
- To use the battery pack up on your camera, leave the POWER switch to on in slide show playback mode until the power goes off.

### Battery life

- The battery life is limited. Battery capacity decreases little by little as you use it more and more, and as time passes. When the battery operating time is shortened considerably, a probable cause is that the battery pack has reached the end of its life. Please buy a new battery pack.
- The battery life varies according to how it is stored and operating conditions and environment for each battery pack.

## Troubleshooting

If you experience trouble with your camera, first check the following items. Should your camera still not operate properly after you have made these checks, press the reset button located on the bottom. (If you press the reset button, the date and time setting is cleared.) Should your camera still not operate properly, consult your Sony dealer or local authorized Sony service facility. **If code displays (C: □□□□) appear on the LCD screen, the self-diagnosis display function is working (page 91).**

Symptom	Cause and/or Solution
Your camera does not work.	<ul style="list-style-type: none"> <li>• You are not using an "InfoLITHIUM" battery pack.                             <ul style="list-style-type: none"> <li>→ Use an "InfoLITHIUM" battery pack (page 10).</li> </ul> </li> <li>• The battery level is low (the  indicator appears on the LCD screen).                             <ul style="list-style-type: none"> <li>→ Charge the battery pack (page 11).</li> </ul> </li> <li>• The AC power adaptor is not connected securely.                             <ul style="list-style-type: none"> <li>→ Connect it firmly to the DC IN jack of your camera and a wall outlet (mains) (pages 11, 14).</li> </ul> </li> <li>• The built-in microcomputer is not working properly.                             <ul style="list-style-type: none"> <li>→ Disconnect and then reconnect all power sources after one minute. Then turn the power on by sliding the POWER switch and check that the camera works properly. Press the reset button located on the bottom using a sharp-pointed object.</li> </ul> </li> </ul>
Your camera cannot record images.	<ul style="list-style-type: none"> <li>• You cannot record images while charging the flash.</li> <li>• The mode dial is set to  or SET UP.                             <ul style="list-style-type: none"> <li>→ Set it to , S, A, M, SCN or  (pages 19, 26).</li> </ul> </li> <li>• No "Memory Stick" has been inserted into your camera.                             <ul style="list-style-type: none"> <li>→ Insert a "Memory Stick" (page 17).</li> </ul> </li> <li>• The write-protect tab on the "Memory Stick" is set to LOCK.                             <ul style="list-style-type: none"> <li>→ Set it to the recording position.</li> </ul> </li> </ul>
The LCD screen does not light when the power is turned on.	<ul style="list-style-type: none"> <li>• The power was turned off with the LCD screen set to OFF the last time the camera was used.                             <ul style="list-style-type: none"> <li>→ The camera retains the settings from the last time it was used. If you turn the power off with the LCD screen set to OFF, the LCD is still set to OFF the next time you turn the power on.</li> </ul> </li> </ul>

Symptom	Cause and/or Solution
The picture is out of focus.	<ul style="list-style-type: none"> <li>Your camera is not in macro recording mode when you shoot a subject that is within 50 cm (19 3/4 inches) from the lens. <ul style="list-style-type: none"> <li>→ Set the macro recording mode (page 58).</li> <li>→ Press the zoom button to set to the W side.</li> </ul> </li> <li>The LANDSCAPE mode of the SCENE SELECTION function is selected. <ul style="list-style-type: none"> <li>→ Cancel the function.</li> </ul> </li> <li>The focus preset is selected. <ul style="list-style-type: none"> <li>→ Cancel the function (page 58).</li> </ul> </li> <li>[CONVERSION LENS] is set to [ON]. <ul style="list-style-type: none"> <li>→ Set it to [OFF] (page 77).</li> </ul> </li> </ul>
The resizing function does not work.	<ul style="list-style-type: none"> <li>You cannot resize moving images, text images, Clip Motion and uncompressed images.</li> </ul>
Images recorded in TEXT mode are blurry.	<ul style="list-style-type: none"> <li>Light is not striking the subject evenly. <ul style="list-style-type: none"> <li>→ Adjust so that the lighting strikes the subject evenly.</li> </ul> </li> </ul>
You cannot record images in TEXT mode.	<ul style="list-style-type: none"> <li>The mode dial is set to  S, A, M or SCN. <ul style="list-style-type: none"> <li>→ Set the mode dial to .</li> </ul> </li> </ul>
You cannot display a print mark.	<ul style="list-style-type: none"> <li>You cannot display print marks on moving images, text images and Clip Motion images.</li> </ul>
The picture is noisy.	<ul style="list-style-type: none"> <li>Your camera is placed near a TV or other equipment that uses strong magnets. <ul style="list-style-type: none"> <li>→ Move your camera away from the TV, etc.</li> </ul> </li> </ul>
The picture is too dark.	<ul style="list-style-type: none"> <li>You are shooting a subject with a light source behind the subject. <ul style="list-style-type: none"> <li>→ Adjust the exposure (page 59).</li> </ul> </li> <li>The brightness of the LCD screen is too low. <ul style="list-style-type: none"> <li>→ Adjust the brightness of the LCD screen (page 77).</li> </ul> </li> </ul>

84

Symptom	Cause and/or Solution
You cannot charge the battery.	<ul style="list-style-type: none"> <li>The camera is turned on. <ul style="list-style-type: none"> <li>→ Turn the camera off (page 11).</li> </ul> </li> </ul>
The POWER ON/OFF (CHG) indicator flashes.	<ul style="list-style-type: none"> <li>The battery pack is not installed correctly. <ul style="list-style-type: none"> <li>→ Install the battery pack correctly (page 10).</li> </ul> </li> <li>The battery pack has malfunctioned. <ul style="list-style-type: none"> <li>→ Contact your Sony dealer or local authorized Sony service facility.</li> </ul> </li> </ul>
The zoom does not work.	<ul style="list-style-type: none"> <li>[CONVERSION LENS] in the setup setting is set to [ON]. <ul style="list-style-type: none"> <li>→ Set it to [OFF] (page 77).</li> </ul> </li> <li>The zoom cannot be used when recording a moving image with [MOVING IMAGE] set to [MPEG MOVIE].</li> </ul>
Digital zoom does not function.	<ul style="list-style-type: none"> <li>The digital zoom cannot be used when recording a moving image with [MOVING IMAGE] set to [MPEG MOVIE], or the LCD screen is OFF. <ul style="list-style-type: none"> <li>[DIGITAL ZOOM] is set to [OFF]. <ul style="list-style-type: none"> <li>→ Set [DIGITAL ZOOM] to [ON] in the menu settings.</li> </ul> </li> </ul> </li> </ul>
Your camera cannot play back images.	<ul style="list-style-type: none"> <li>The mode dial is set to  M, A, S, SCN or SET UP. <ul style="list-style-type: none"> <li>→ Set it to  (pages 28, 29).</li> </ul> </li> </ul>
The image and sound are interfered by noise when you play back an image on a personal computer.	<ul style="list-style-type: none"> <li>You are playing back the file directly from the "Memory Stick." <ul style="list-style-type: none"> <li>→ Copy the file to the hard disk of the personal computer and then play back the file from the hard disk (page 36).</li> </ul> </li> </ul>
The image cannot be played back on a personal computer.	<ul style="list-style-type: none"> <li>→ Consult the personal computer or software manufacturer.</li> </ul>
Your camera cannot delete an image.	<ul style="list-style-type: none"> <li>The image is protected. <ul style="list-style-type: none"> <li>→ Cancel the protection (page 68).</li> </ul> </li> </ul>
The power turns off suddenly.	<ul style="list-style-type: none"> <li>If you do not operate the camera for about three minutes while the power is on, the camera turns off automatically to prevent wearing down the battery (page 20). <ul style="list-style-type: none"> <li>→ Turn on the camera.</li> </ul> </li> <li>The battery is discharged. <ul style="list-style-type: none"> <li>→ Replace it with a charged battery.</li> </ul> </li> </ul>

86

Symptom	Cause and/or Solution
The flash does not work.	<ul style="list-style-type: none"> <li>The flash is set to . <ul style="list-style-type: none"> <li>→ Set the flash to auto (no indicator) or  (page 24).</li> </ul> </li> <li>The camera is in one of the following SCENE SELECTION modes: TWILIGHT or LANDSCAPE. <ul style="list-style-type: none"> <li>→ Cancel the SCENE SELECTION function (page 51) or set the flash to .</li> </ul> </li> <li>The mode dial is set to . SETUP or  (MPEG MOVIE). <ul style="list-style-type: none"> <li>→ Set it to .</li> </ul> </li> <li>[MODE] (REC MODE) is set to [BURST2] in the menu settings. <ul style="list-style-type: none"> <li>→ Set it to other modes.</li> </ul> </li> </ul>
The date and time are recorded incorrectly.	<ul style="list-style-type: none"> <li>The date and time are not set correctly. <ul style="list-style-type: none"> <li>→ Set the correct date and time (page 15).</li> </ul> </li> </ul>
Vertical streaks appear when you are shooting a very bright subject.	<ul style="list-style-type: none"> <li>The smear phenomenon is happening. <ul style="list-style-type: none"> <li>→ This is not a malfunction.</li> </ul> </li> </ul>
The battery life is short.	<ul style="list-style-type: none"> <li>You are recording/playing back images under extremely cold temperatures. <ul style="list-style-type: none"> <li>The battery pack is not charged enough. <ul style="list-style-type: none"> <li>→ Charge the battery pack fully.</li> </ul> </li> <li>The battery pack is dead. <ul style="list-style-type: none"> <li>→ Replace the battery pack with a new one (page 10).</li> </ul> </li> </ul> </li> </ul>
The battery remaining indicator is incorrect. Or sufficient battery remaining indicator is displayed but the power runs out soon.	<ul style="list-style-type: none"> <li>You have used the camera for a long time in an extremely hot or an extremely cold location. <ul style="list-style-type: none"> <li>The battery pack is dead. <ul style="list-style-type: none"> <li>→ Replace the battery pack with a new one (page 10).</li> </ul> </li> <li>The battery pack is discharged. <ul style="list-style-type: none"> <li>→ Install a charged battery pack (pages 10, 11).</li> </ul> </li> <li>A deviation has occurred in the remaining battery time. <ul style="list-style-type: none"> <li>→ Fully charge the battery pack (page 11).</li> </ul> </li> </ul> </li> </ul>
Nothing appears in the display window or the indicators flash during charging.	<ul style="list-style-type: none"> <li>The AC power adaptor is disconnected. <ul style="list-style-type: none"> <li>→ Firmly connect the power cord to the wall outlet (page 14).</li> </ul> </li> <li>The battery pack is not installed correctly. <ul style="list-style-type: none"> <li>→ Install the battery pack correctly (page 10).</li> </ul> </li> <li>Charging is completed.</li> </ul>

85

Symptom	Cause and/or Solution
The image does not appear on the TV screen.	<ul style="list-style-type: none"> <li>The video output signal setting of your camera is incorrect. <ul style="list-style-type: none"> <li>→ Change the setting (page 77).</li> </ul> </li> </ul>
A file error occurs when you play back a file.	<ul style="list-style-type: none"> <li>The image size is larger than 2048×1536. <ul style="list-style-type: none"> <li>→ Use an image size of 2048×1536 or smaller.</li> </ul> </li> </ul>
The picture is monochrome (black and white).	<ul style="list-style-type: none"> <li>The camera is set to TEXT mode. <ul style="list-style-type: none"> <li>→ Cancel TEXT mode (page 55).</li> </ul> </li> <li>P. EFFECT is set to B&amp;W mode. <ul style="list-style-type: none"> <li>→ Cancel B&amp;W mode (page 61).</li> </ul> </li> </ul>
The lens does not retract even when the power is turned off.	<ul style="list-style-type: none"> <li>The battery is discharged. <ul style="list-style-type: none"> <li>→ Replace it with a fully charged battery or use the AC power adaptor.</li> </ul> </li> </ul>
Your personal computer does not recognize your camera.	<ul style="list-style-type: none"> <li>The battery level is low. <ul style="list-style-type: none"> <li>→ Use the AC power adaptor (page 14).</li> </ul> </li> <li>The camera is turned off. <ul style="list-style-type: none"> <li>→ Turn on the camera.</li> </ul> </li> <li>The USB cable is not connected firmly. <ul style="list-style-type: none"> <li>→ Disconnect the USB cable, and connect it again firmly. Make sure that "USB MODE" is displayed on the LCD screen (pages 33, 35).</li> </ul> </li> <li>The USB connectors on your personal computer are connected to other equipment besides the keyboard, the mouse, and your camera. <ul style="list-style-type: none"> <li>→ Disconnect the USB cables except for the ones connected to the keyboard, the mouse, and your camera.</li> </ul> </li> <li>The USB driver is not installed. <ul style="list-style-type: none"> <li>→ Install the USB driver (page 33).</li> </ul> </li> <li>[USB CONNECT] is set to [PTP] in the setup settings. <ul style="list-style-type: none"> <li>→ Set it to [NORMAL] (page 77).</li> </ul> </li> <li>Since the camera is connected to a computer with the USB cable before installing the USB driver, the drive is not recognized by the computer. <ul style="list-style-type: none"> <li>→ Delete the drive which is not recognized, then install the USB driver. For details, see the procedure on page 88.</li> </ul> </li> </ul>
No function works though the power is on.	<ul style="list-style-type: none"> <li>→ Remove the battery pack, then install it again after about one minute. If the function still do not work, press the reset button located on the bottom using a sharp-pointed object. (If you press the reset button, the date and time setting is cleared.)</li> </ul>

87

Reinstall the USB driver when using Windows 98, Windows 98SE, Windows Me and Windows 2000 Professional. Perform all steps without skipping.

- 1 Turn on your computer and allow Windows to load.
- 2 Connect the USB jack on the camera and the computer with the supplied USB cable.
- 3 Insert a "Memory Stick".
- 4 Connect the AC power adaptor to your camera and then to a wall outlet (mains), and turn on the power of your camera.
- 5 Open "Device Manager" on Windows.
 

**For Windows 98, Windows 98SE and Windows Me users:**

  - ① Open [Control Panel] from [My Computer], then double-click [System].
  - ② "System properties" is displayed. Click the [Device Manager] tab located at the top.
  - ③ Click [Sony DSC] in [Other devices], then click the [Delete (E)] button located at the lower-right corner.

**For Windows 2000 Professional users:**  
\* Log in with the permission of administrator.

  - ① Open [Control Panel] from [My Computer], then double-click [System].
  - ② "System properties" is displayed. Click the [Hardware] tab located at the top, then click the [Device Manager (D)] button.
  - ③ Click [View] in [Device Manager], then click [Devices by type (E)].
  - ④ Right-click [Sony DSC] in [Other devices], then click [Delete (E)].
- 6 After the message appears to verify that you delete the device, click "OK."
- 7 Turn off the camera, disconnect the USB cable, and restart the computer.
- 8 Install the USB driver in the supplied CD-ROM to the computer following the procedure on page 33.

88

Message	Meaning
	The battery level is low or zero. Depending on the conditions of use or the type of battery pack, the indicator may flash even though there is still 5 to 10 minutes of remaining battery time left.
LENS CAP ATTACHED	The lens cap is still attached to the lens.
CANNOT DIVIDE	<ul style="list-style-type: none"> <li>• The file is not long enough to be divided.</li> <li>• The file is not a moving image.</li> </ul>
	The amount of light is not sufficient or the shutter speed is too slow. (Mount the camera on a tripod or otherwise secure the camera in place.)
TURN THE POWER OFF AND ON AGAIN	A malfunction occurs on the lens.

90

## Warning and notice messages

Various messages appear on the LCD screen. Check the corresponding descriptions in the following list.

Message	Meaning
NO MEMORY STICK	No "Memory Stick" has been inserted.
SYSTEM ERROR	Turn the power off and on again.
MEMORY STICK ERROR	<ul style="list-style-type: none"> <li>• The inserted "Memory Stick" cannot be used with your camera, or is damaged.</li> <li>• The "Memory Stick" is not inserted correctly.</li> </ul>
FORMAT ERROR	Failed to format the "Memory Stick."
MEMORY STICK LOCKED	The write-protect tab on the "Memory Stick" is set to the LOCK position.
NO MEMORY SPACE	The capacity of the "Memory Stick" is full, and you cannot record or copy images.
NO FILE	No image has been recorded on the "Memory Stick."
FILE ERROR	An error occurred while playing back the image.
FILE PROTECT	The image is protected against erasure.
for "InfoLITHIUM" battery only	The battery is not the "InfoLITHIUM" type.
NOT ENOUGH MEMORY	The images you want to copy are too big to copy with your camera.
COPY ERROR	Copying was not performed correctly, or the "Memory Stick" was removed during copying.
DIRECTORY ERROR	A directory with the same name already exists.
IMAGE SIZE OVER	You are playing back an image of a size that cannot be played back with your camera.
INVALID OPERATION	You are playing back a file that was created on equipment other than your camera.

Additional information

89

## Self-diagnosis display

Your camera has a self-diagnosis display. This function displays the camera condition on the LCD screen with a combination of a letter and four digits of numbers. If this occurs, check the following code chart. The code informs you of the camera's current condition. The last two digits (indicated by □□) will differ depending on the state of the camera.

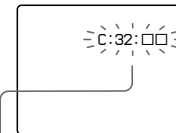

### Self-diagnosis display

- C:□□:□□  
You can reverse the camera malfunction yourself.
- E:□□:□□  
Contact your Sony dealer or local authorized Sony service facility.

First three digits	Cause and/or Corrective Action
C:32:□□	<ul style="list-style-type: none"> <li>• There is trouble with your camera's hardware or zooming function.</li> <li>→ Turn the power off and on again.</li> </ul>
C:13:□□	<ul style="list-style-type: none"> <li>• An unformatted "Memory Stick" is inserted.</li> <li>→ Format the "Memory Stick" (page 76).</li> <li>• The inserted "Memory Stick" cannot be used with your camera, or is damaged.</li> <li>→ Insert a new "Memory Stick" (page 17).</li> </ul>
E:61:□□ E:91:□□	<ul style="list-style-type: none"> <li>• A camera malfunction that you cannot reverse has occurred.</li> <li>→ Contact your Sony dealer or local authorized Sony service facility and inform them of the 5-digit service code. (example: E:61:10)</li> </ul>

If you are unable to solve the problem even after trying the corrective actions a few times and when the camera is not reset even if you press the reset button located on the bottom, contact your Sony dealer or local authorized Sony service facility.

When a self-diagnosis display appears  
The error display appears on the display window (page 93).

Additional information

91

## Display window indicators

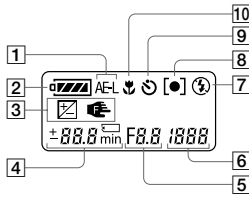

- |   |                                 |
|---|---------------------------------|
| 1 AE lock indicator   | 7 Flash mode indicator          |
| 2 Battery remaining indicator   | 8 Spot light-metering indicator |
| 3 EV indicator/Focus lock indicator   | 9 Self-timer indicator          |
| 4 Remaining number of recordable images indicator/EV level indicator/Focus distance indicator/Battery usable time indicator (displayed only during charging)  | 10 Macro mode indicator         |
| 5 Aperture value indicator  |                                 |
| 6 Shutter speed indicator<br>Error display<br><i>Err</i> : Some kind of misoperation has occurred. Check the self-diagnosis display on the LCD screen (page 91) and take the appropriate corrective action.<br><i>LENS</i> : A problem has occurred with lens drive. Turn the camera on and off several times, and if the problem persists, contact your Sony dealer or authorized Sony service facility. |                                 |

Additional information

## LCD screen indicators

### The indicators during recording still images

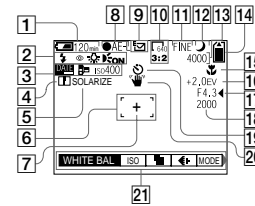

- |   |  |
|---|--|
| 1 Battery remaining indicator   | 12 Mode dial indicator   |
| 2 Flash mode/red eye reduction/white balance/AF illuminator indicator | 13 Remaining number of recordable images indicator/Self-diagnosis function indicator |
| 3 Date/time/conversion lens/ISO number indicator                      | 14 Remaining memory capacity indicator   |
| 4 Sharpness indicator   | 15 Macro /focus mode  indicator  |
| 5 Picture effect indicator  | 16 EV level indicator  |
| 6 AF frame  | 17 Aperture value indicator  |
| 7 Spot light-metering cross hair                                      | 18 Shutter speed indicator   |
| 8 AE/AF lock indicator  | 19 Self-timer indicator  |
| 9 Recording mode indicator  | 20 Light amount warning indicator  |
| 10 Image size indicator   | 21 Menu and guide menu<br>Pressing MENU switches the menu on/off.                    |
| 11 Image quality indicator  |  |

### The indicators during recording moving images

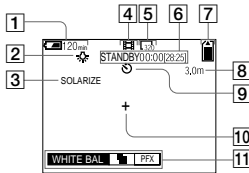

- |  |   |
|--|---|
| 1 Battery remaining indicator  | 7 Remaining memory capacity indicator                             |
| 2 White balance indicator  | 8 Macro /focus mode  indicator                                    |
| 3 Picture effect indicator   | 9 Self-timer indicator  |
| 4 Recording mode indicator   | 10 Spot light-metering cross hair                                 |
| 5 Image size indicator   | 11 Menu and guide menu<br>Pressing MENU switches the menu on/off. |
| 6 Recording time (maximum recordable time) indicator/Self-diagnosis function indicator |   |

Additional information

### When playing back still images

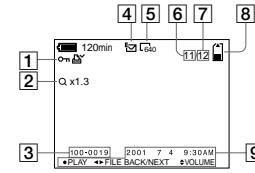

- |                                |  |
|--------------------------------|--|
| 1 Protect/print mark indicator | 7 Number of stored images in "Memory Stick"                |
| 2 Zoom scaling indicator       | 8 Remaining memory capacity indicator                      |
| 3 File name                    | 9 Recording date of the playback image/menu and guide menu |
| 4 Recording mode indicator     |  |
| 5 Image size indicator         |  |
| 6 Image number                 |  |

### When playing back moving images

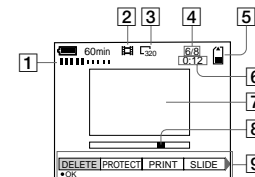

- |  |  |
|--|--|
| 1 VOL. (Volume) indicator                                | 6 Counter  |
| 2 Recording mode indicator                               | 7 Playback image                                       |
| 3 Image size indicator                                   | 8 Play bar   |
| 4 Image number/number of stored images in "Memory Stick" | 9 Menu and guide menu (play/pause/fast-forward/rewind) |
| 5 Remaining memory capacity indicator                    |  |

## SECTION 2 DISASSEMBLY

• This set can be disassembled in the order shown below.

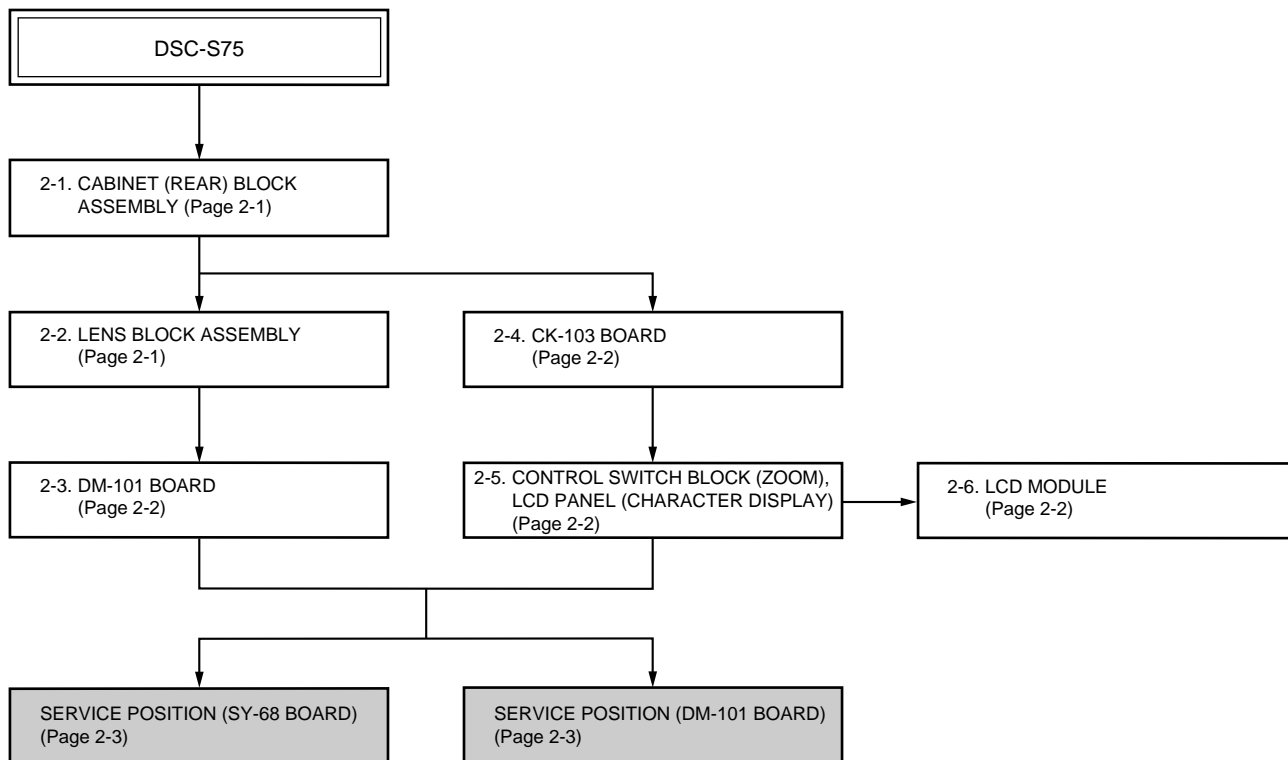

**Note:** Follow the disassembly procedure in the numerical order given.

### 2-1. CABINET (REAR) BLOCK ASSEMBLY

### 2-2. LENS BLOCK ASSEMBLY

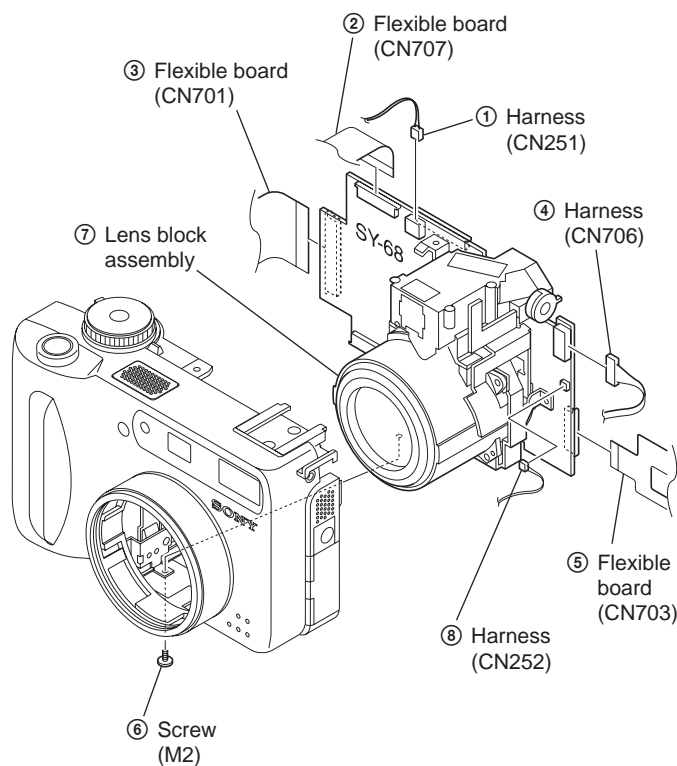
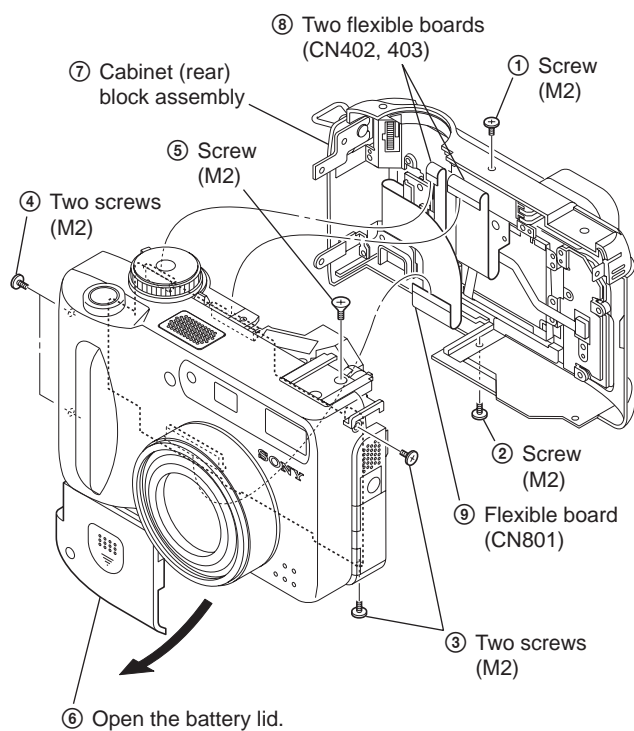

### 2-3. DM-101 BOARD

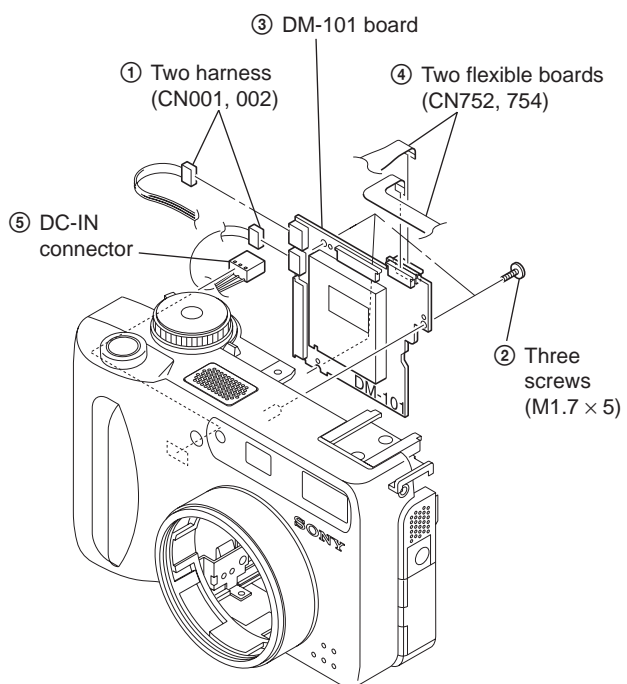

### 2-5. CONTROL SWITCH BLOCK (ZOOM), LCD PANEL (CHARACTER DISPLAY)

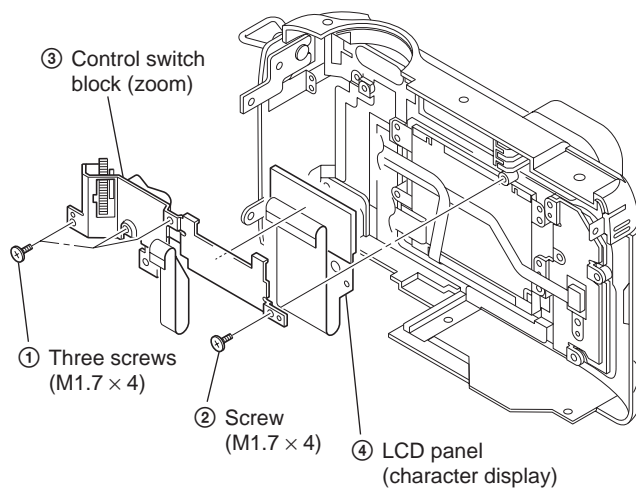

### 2-4. CK-103 BOARD

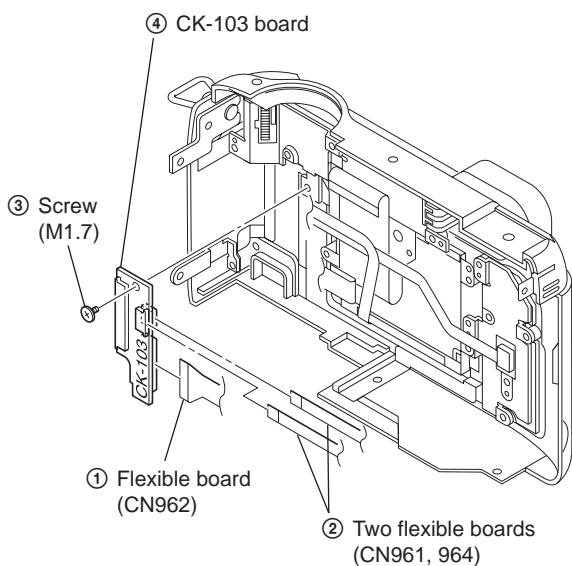

### 2-6. LCD MODULE

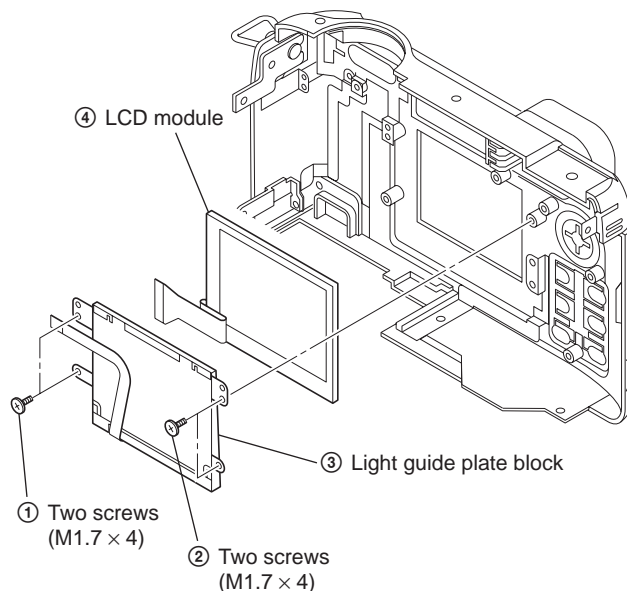

## [SERVICE POSITION (SY-68 BOARD)]

Note: Don't use 12 pin flexible board of CPC-9 jig.  
It causes damage to the unit.

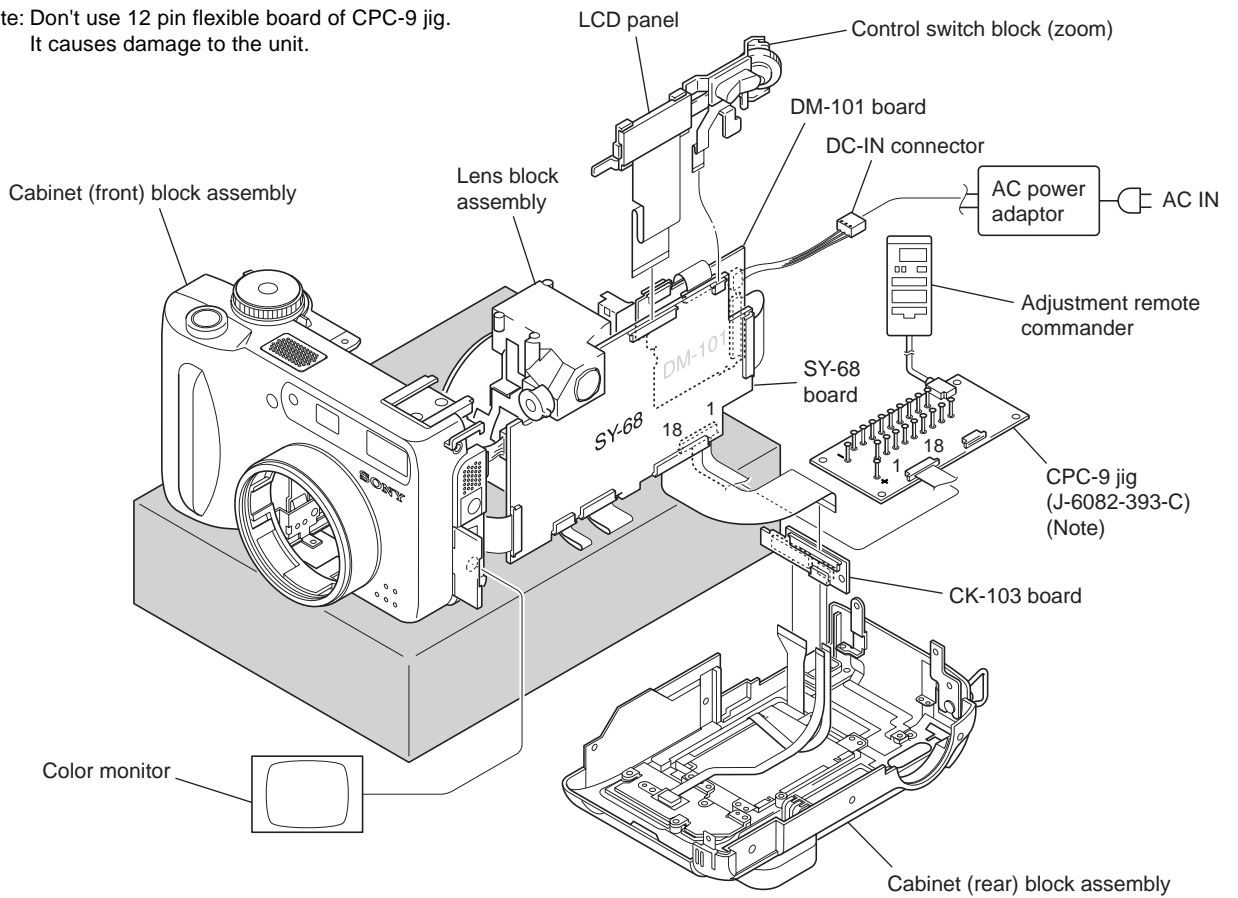

## [SERVICE POSITION (DM-101 BOARD)]

Note: Don't use 12 pin flexible board of CPC-9 jig.  
It causes damage to the unit.

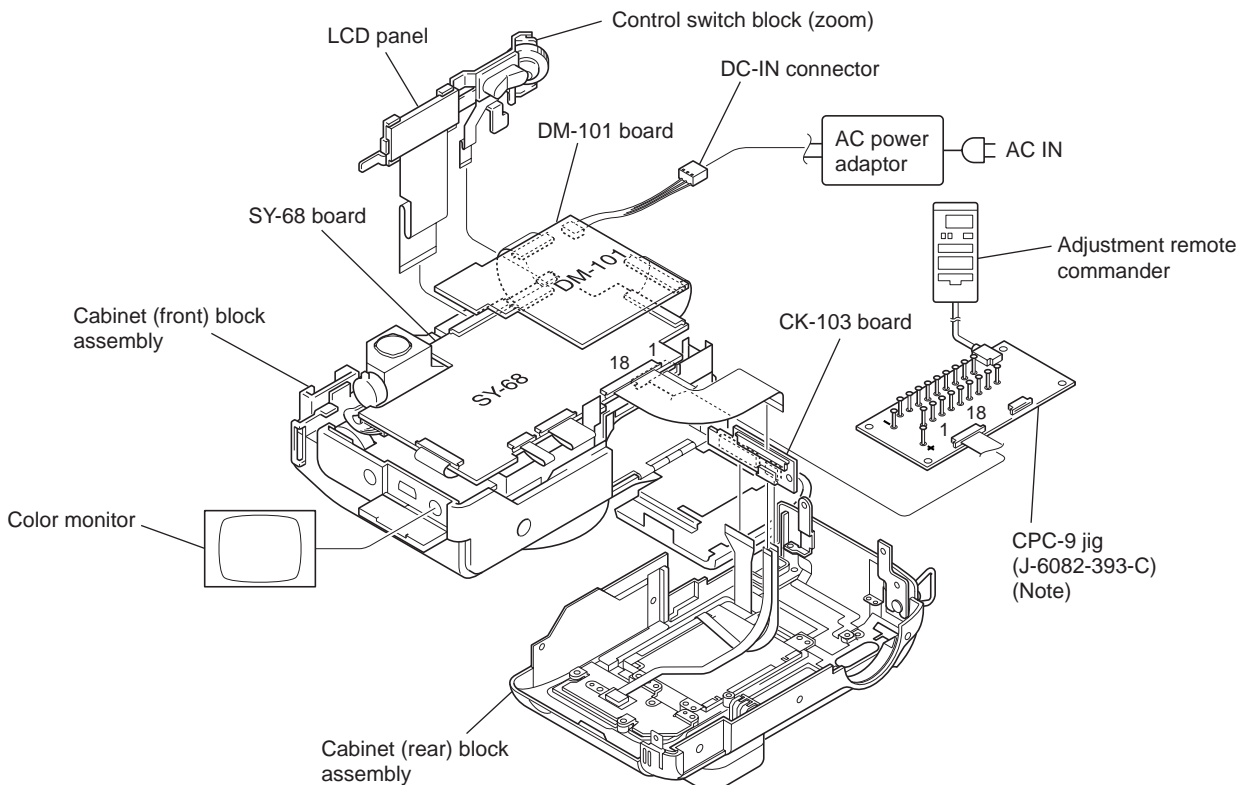

## 2-7. CIRCUIT BOARDS LOCATION

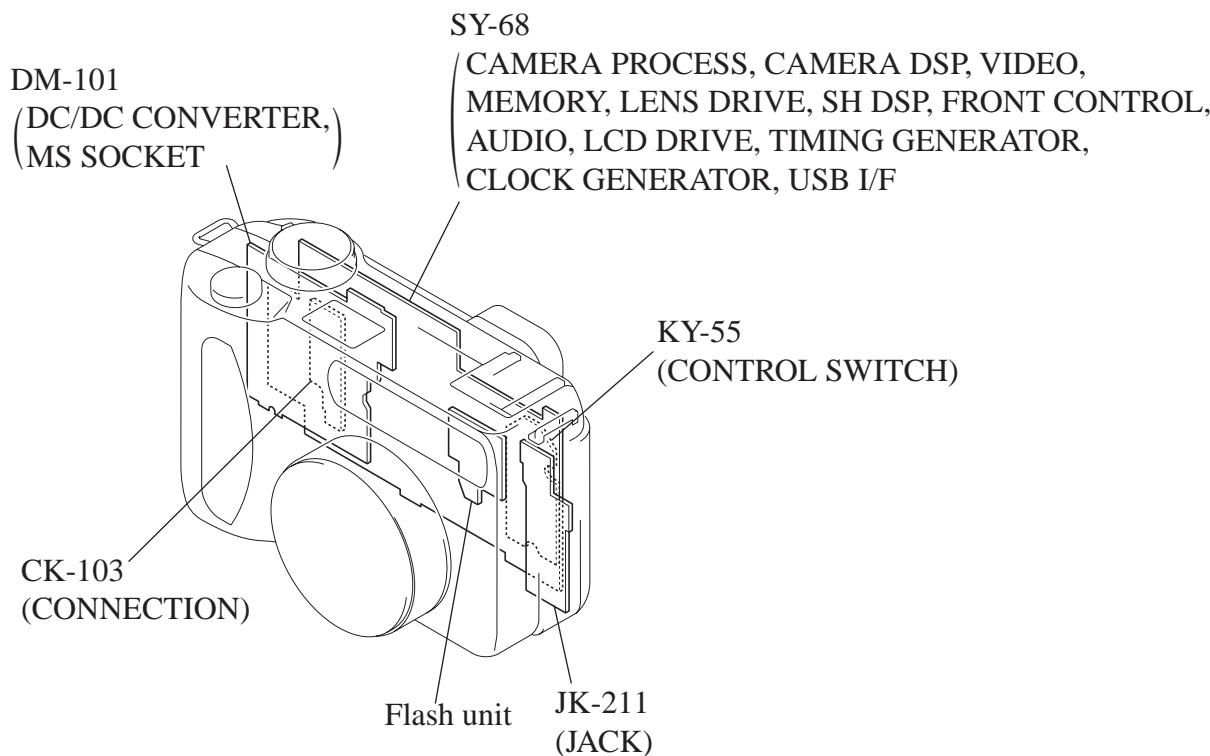

## 2-8. FLEXIBLE BOARDS LOCATION

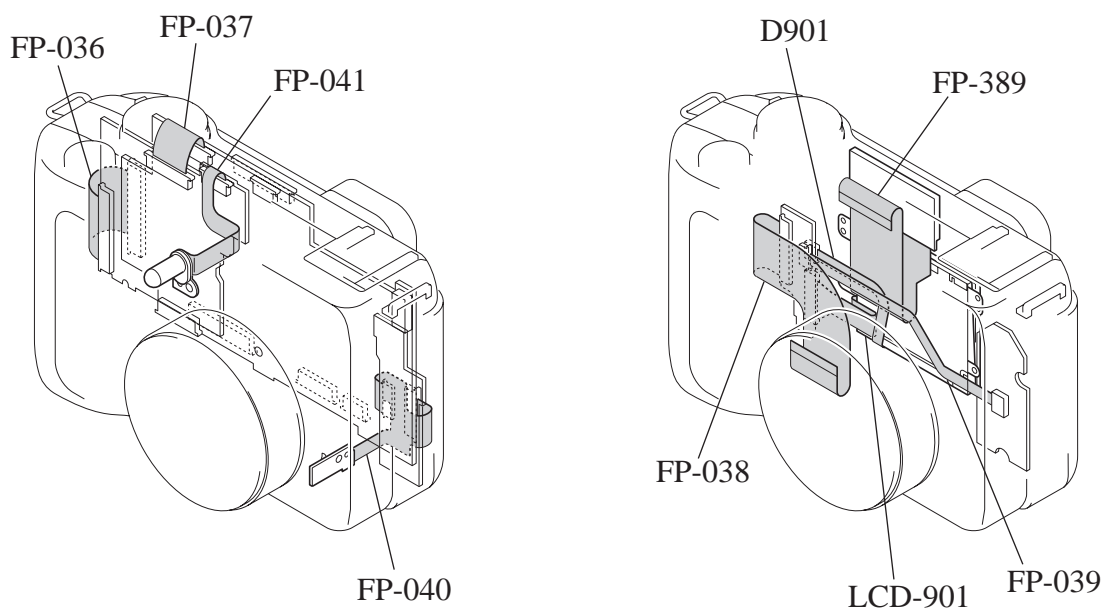

### SECTION 3 BLOCK DIAGRAMS

#### 3-1. OVERALL BLOCK DIAGRAM

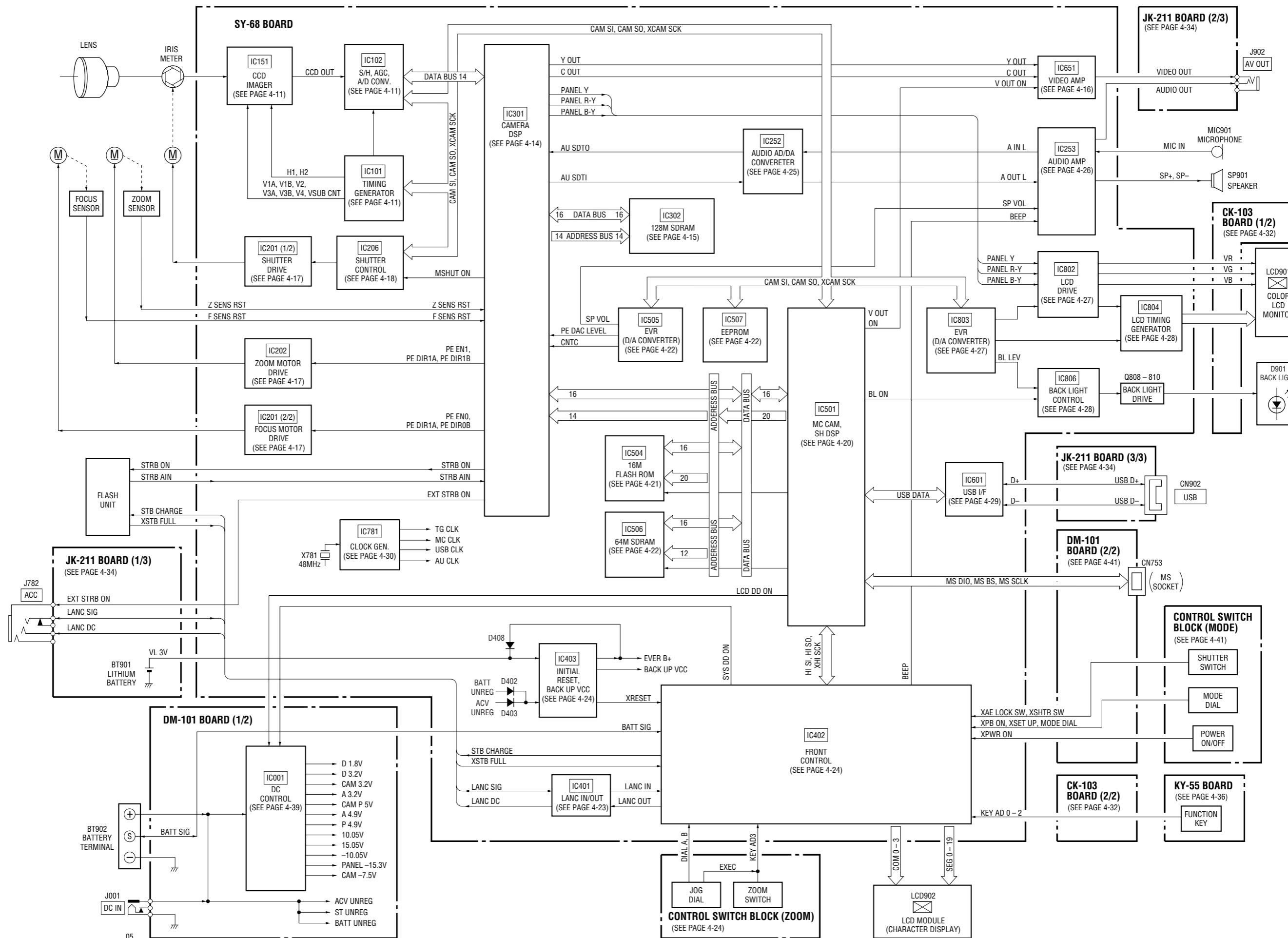

3-8. POWER BLOCK DIAGRAM 1

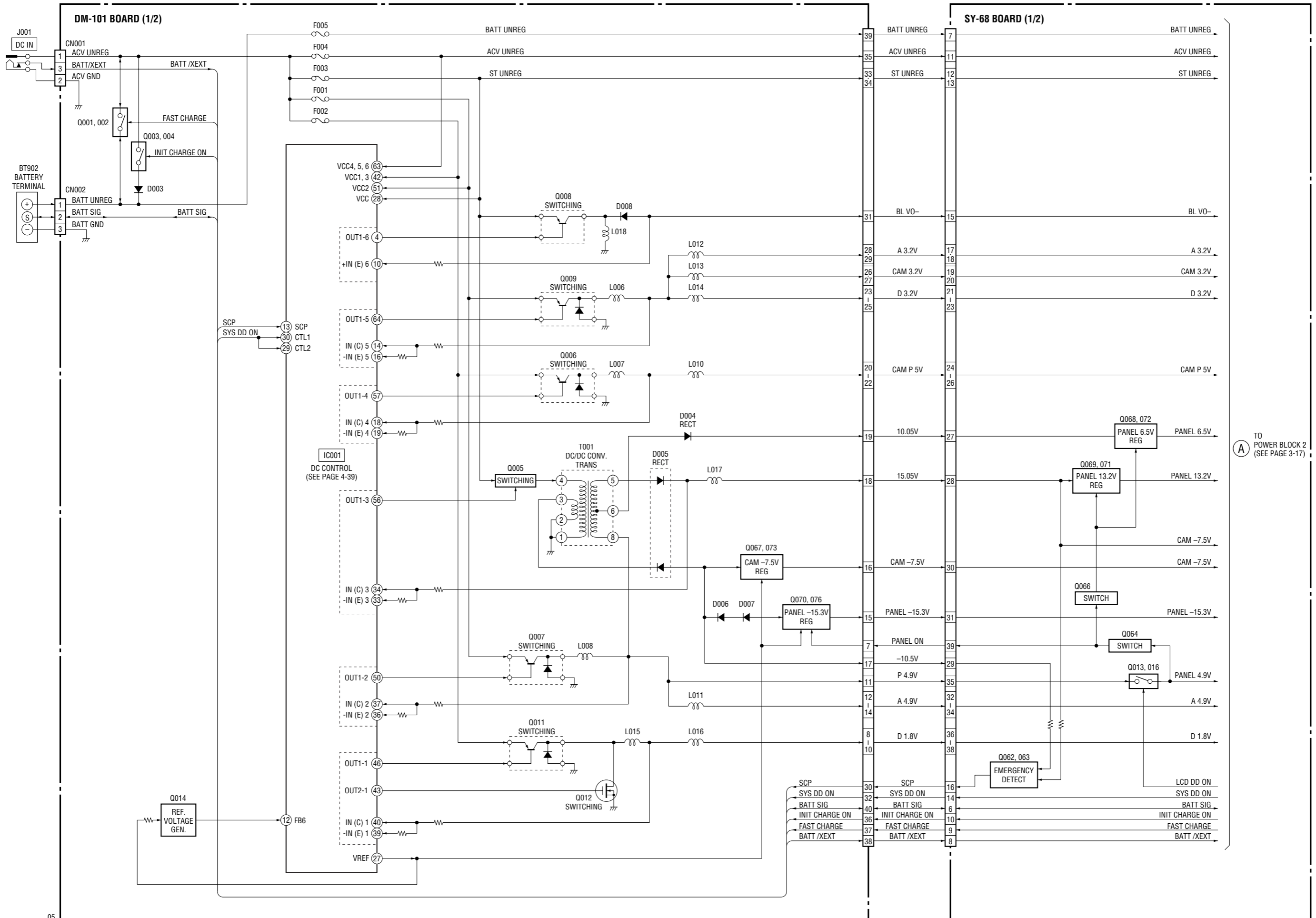

TO POWER BLOCK 2 (SEE PAGE 3-17)

3-9. POWER BLOCK DIAGRAM 2

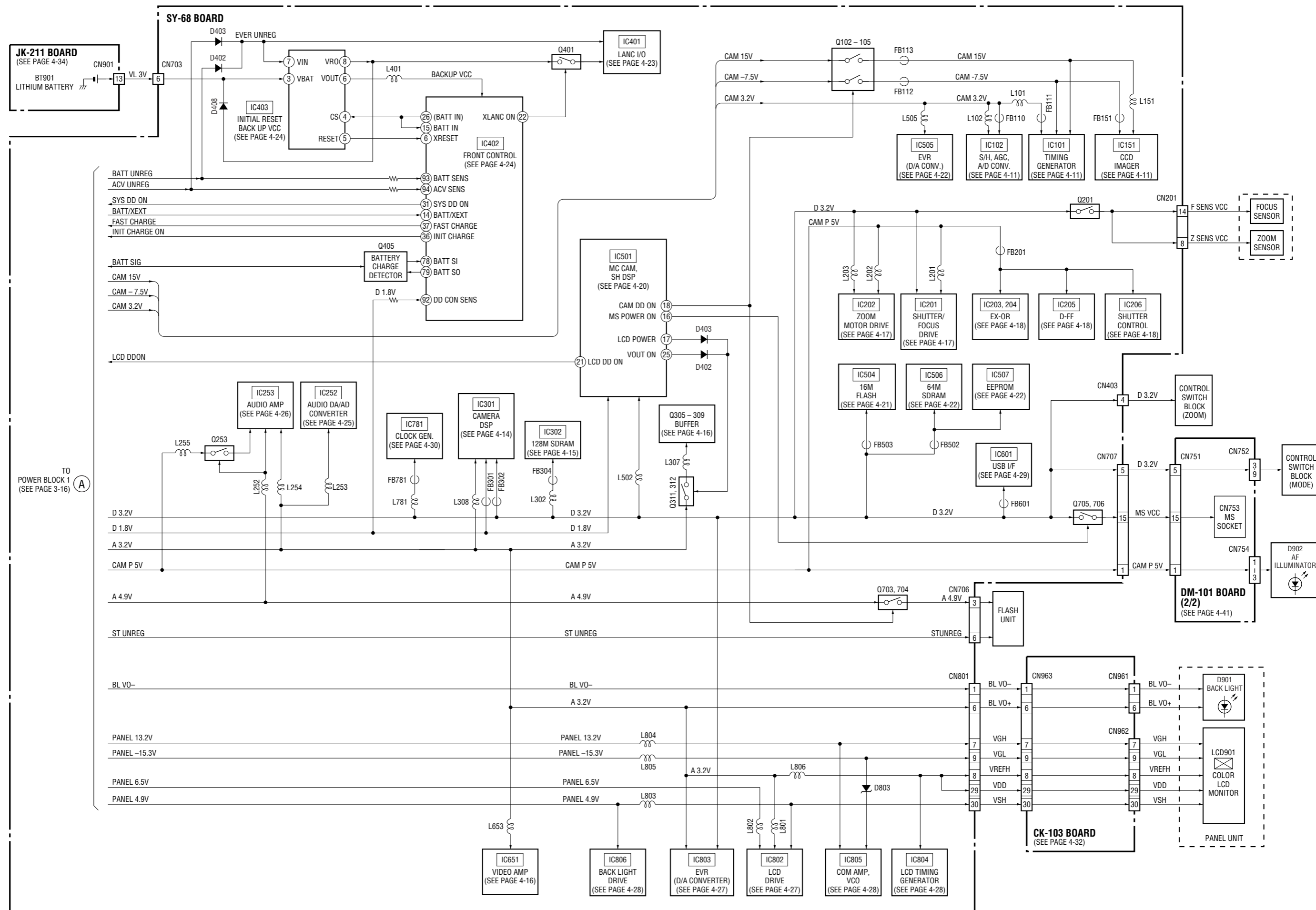



## SECTION 4 PRINTED WIRING BOARDS AND SCHEMATIC DIAGRAMS

### THIS NOTE IS COMMON FOR WIRING BOARDS AND SCHEMATIC DIAGRAMS

(In addition to this, the necessary note is printed in each block)

#### (For printed wiring boards)



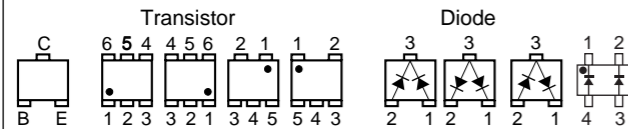



-  : Uses unleaded solder.
-  : Pattern from the side which enables seeing.  
(The other layers' patterns are not indicated)
- Through hole is omitted.
- Circled numbers refer to waveforms.
- There are a few cases that the part printed on diagram isn't mounted in this model.
- Chip parts.

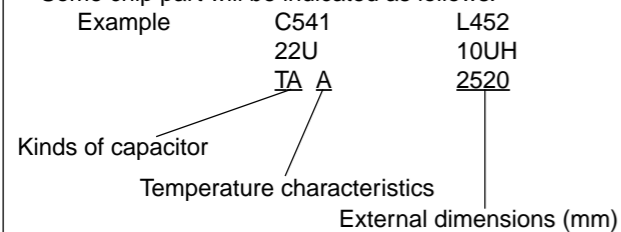

#### (For schematic diagrams)

- All capacitors are in  $\mu\text{F}$  unless otherwise noted.  $\text{pF} : \mu\text{F} : \mu\text{F}$ . 50 V or less are not indicated except for electrolytics and tantalums.
- Chip resistors are 1/10 W unless otherwise noted.  $\text{k}\Omega=1000 \Omega$ ,  $\text{M}\Omega=1000 \text{k}\Omega$ .
- Caution when replacing chip parts.  
New parts must be attached after removal of chip.  
Be careful not to heat the minus side of tantalum capacitor, Because it is damaged by the heat.
- Some chip part will be indicated as follows.



- Constants of resistors, capacitors, ICs and etc with XX indicate that they are not used.  
In such cases, the unused circuits may be indicated.
- Parts with  $\star$  differ according to the model/destination.  
Refer to the mount table for each function.
- All variable and adjustable resistors have characteristic curve B, unless otherwise noted.
- Signal name  
XEDIT  $\rightarrow$  EDIT    PB/XREC  $\rightarrow$  PB/REC
-  : non flammable resistor
-  : fusible resistor
-  : panel designation
-  : B+ Line \*
-  : B- Line \*
-  : IN/OUT direction of (+,-) B LINE. \*
-  : adjustment for repair. \*
- Circled numbers refer to waveforms. \*
- \* Indicated by the color red.

**Note :** The components identified by mark  $\triangle$  or dotted line with mark  $\triangle$  are critical for safety. Replace only with part number specified.

**Note :** Les composants identifiés par une marque  $\triangle$  sont critiques pour la sécurité. Ne les remplacer que par une pièce portant le numéro spécifié.

#### (Measuring conditions voltage and waveform)

- Voltages and waveforms are measured between the measurement points and ground when camera shoots color bar chart of pattern box. They are reference values and reference waveforms. \*
- (VOM of DC 10 M $\Omega$  input impedance is used)
- Voltage values change depending upon input impedance of VOM used.)

#### 1. Connection

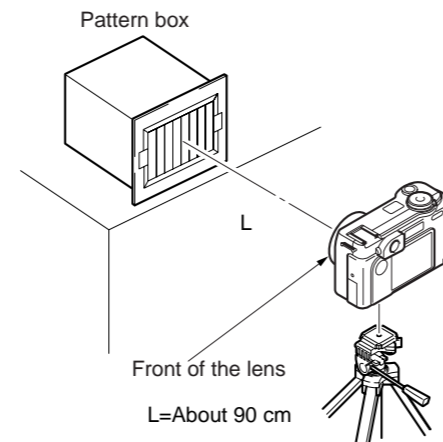

- Adjust the distance so that the output waveform of Fig. a and the Fig. b can be obtain.

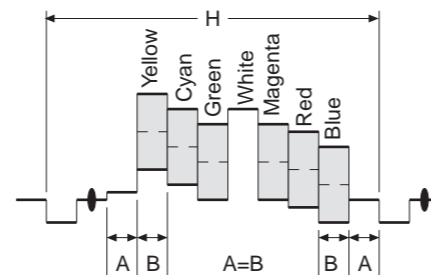

Fig. a (Video output terminal waveform)

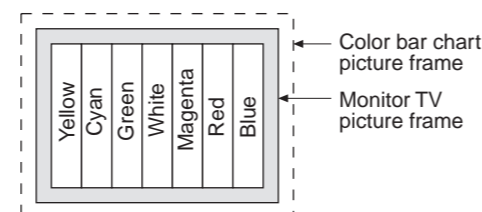
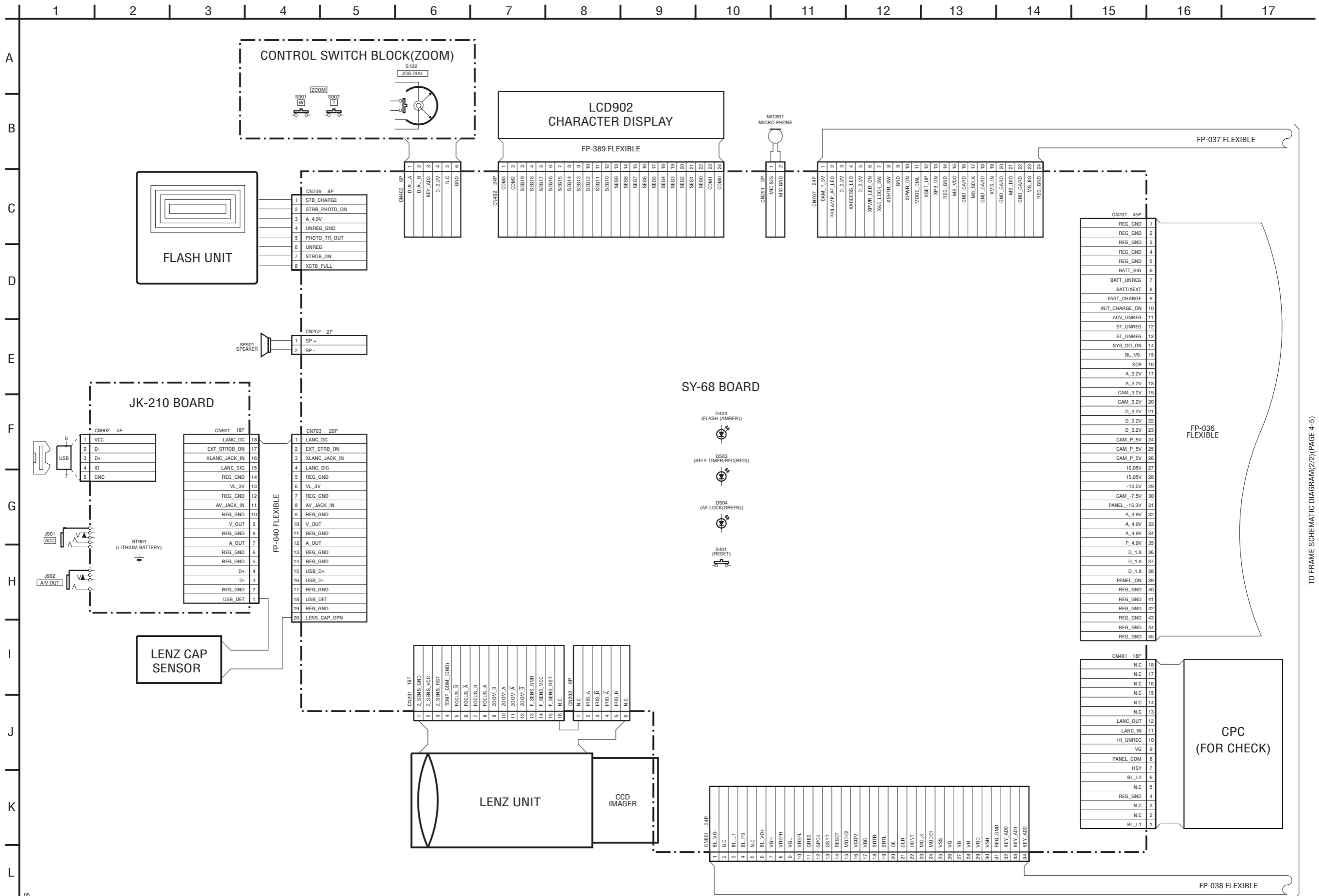

Fig.b (Picture on monitor TV)

When indicating parts by reference number, please include the board name.

4-1. FRAME SCHEMATIC DIAGRAMS

FRAME SCHEMATIC DIAGRAM (1/2)



TO FRAME SCHEMATIC DIAGRAM(2/2)(PAGE 4-5)

FRAME SCHEMATIC DIAGRAM (2/2)

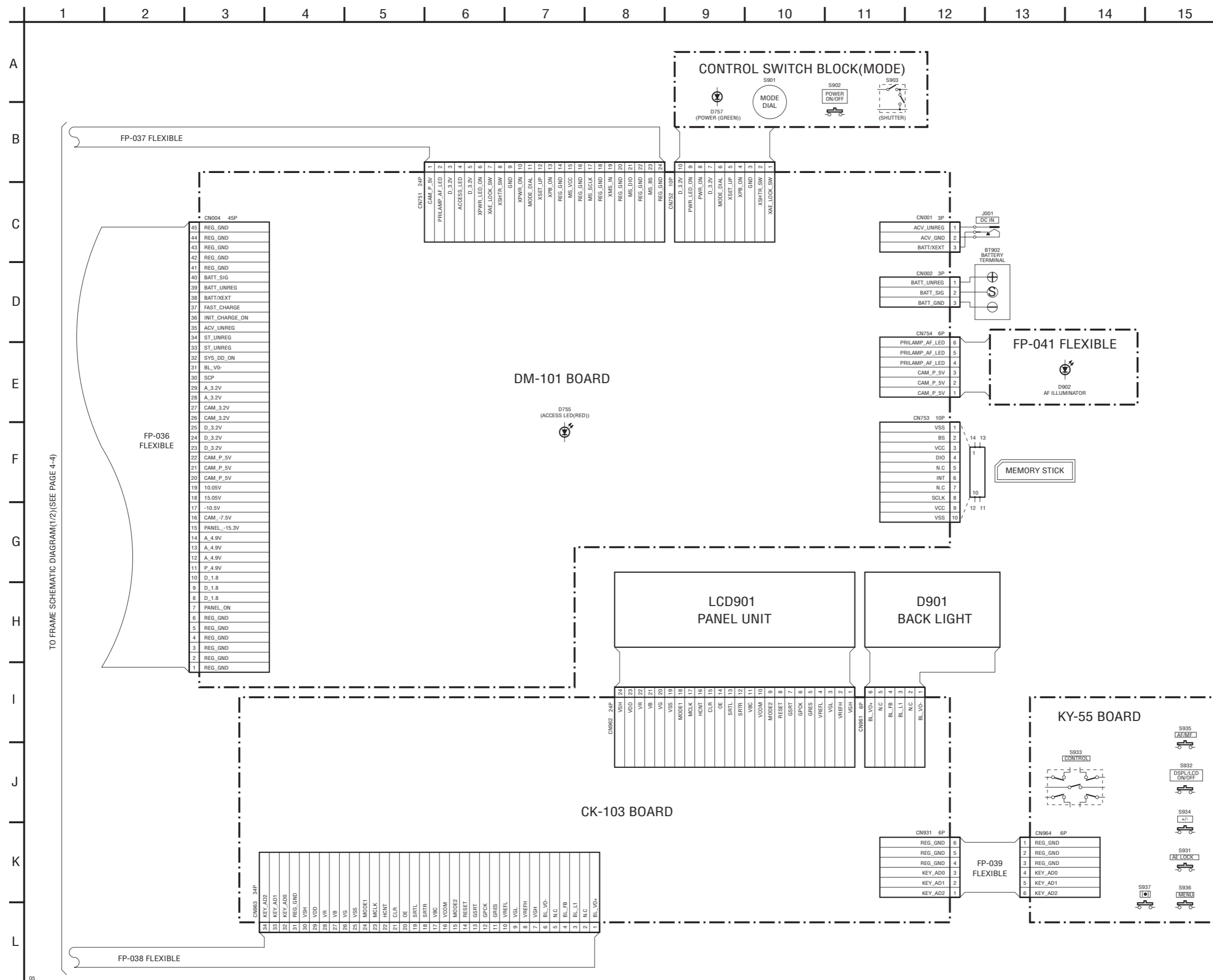

4-2. PRINTED WIRING BOARDS AND SCHEMATIC DIAGRAMS

CK-103 (CONNECTION) PRINTED WIRING BOARD AND SCHEMATIC DIAGRAM

- Ref. No.: CK-103 board; 2,000 series -

• For Printed Wiring Board.

-  : Uses unleaded solder.
- CK-103 board is four-layer print board. However, the patterns of layers 2 to 3 have not been included in the diagram.
- There are a few cases that the part isn't mounted in this model is printed on this diagram.

CK-103 BOARD (SIDE A)

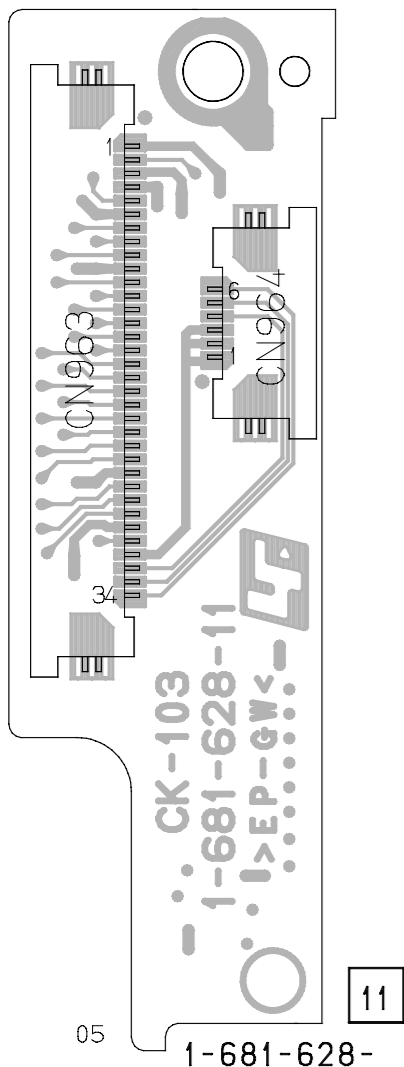

CK-103 BOARD (SIDE B)

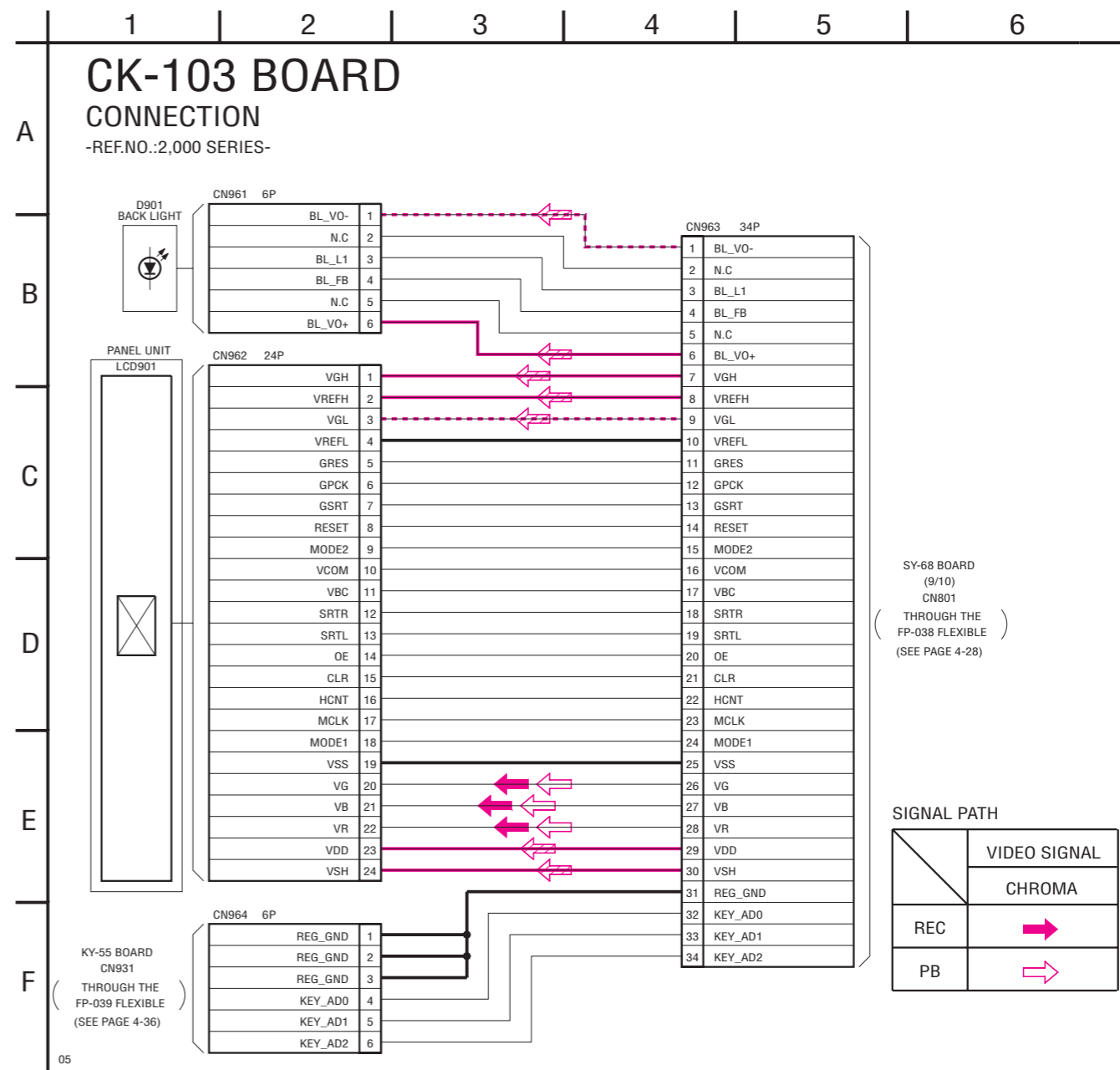
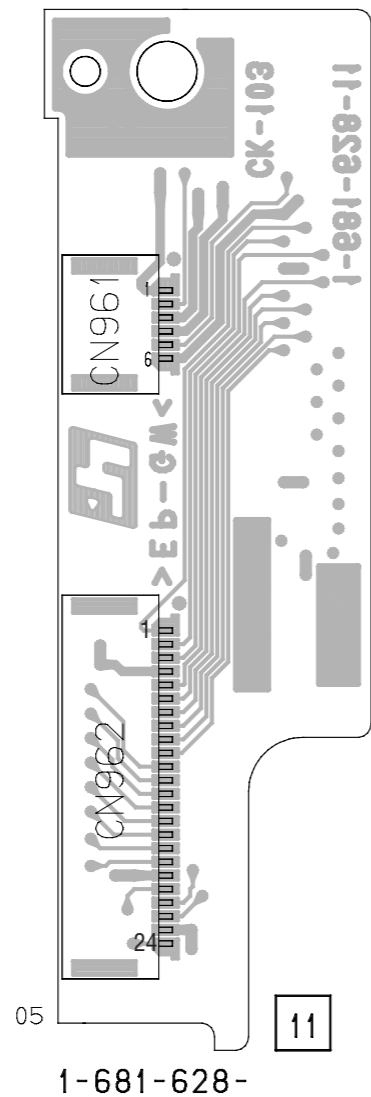

JK-211 (JACK) PRINTED WIRING BOARD AND SCHEMATIC DIAGRAM

- For Printed Wiring Board.
-  :Uses unleaded solder.
- JK-211 board is four-layer print board. However, the patterns of layers 2 to 3 have not been included in the diagram.
- There are a few cases that the part isn't mounted in this model is printed on this diagram.
- See page 4-46 for printed parts location.

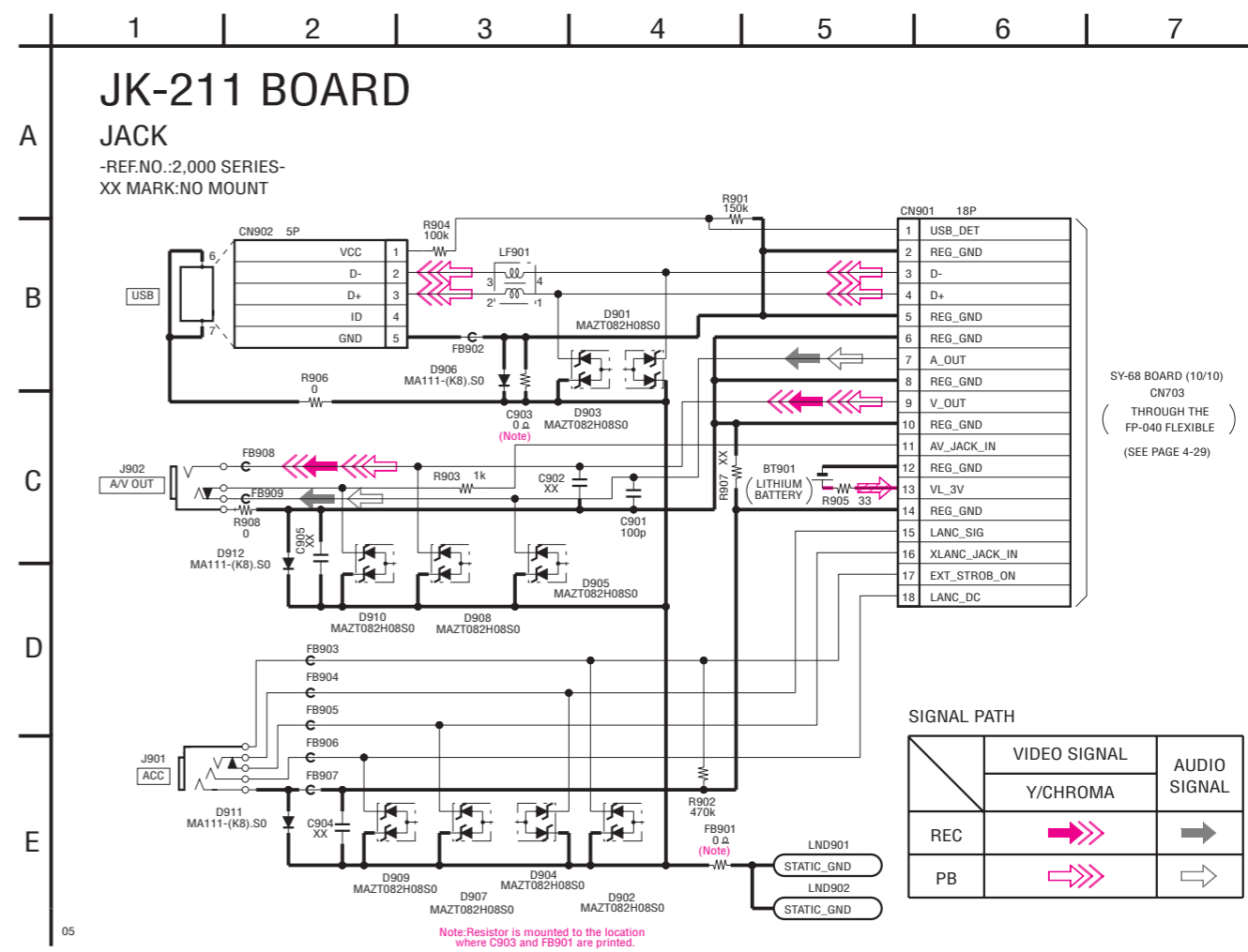
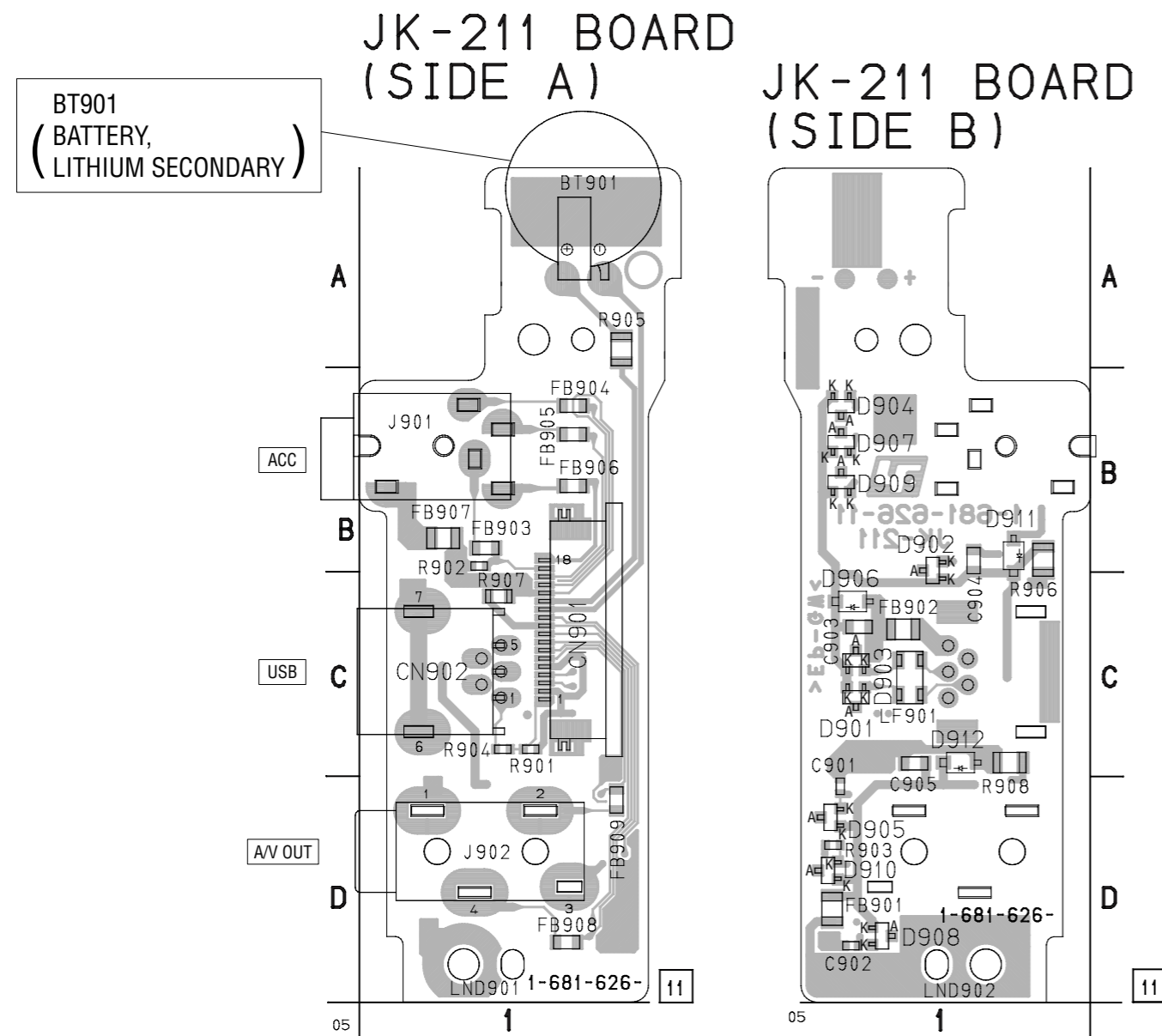

**KY-55 (CONTROL SWITCH) PRINTED WIRING BOARD AND SCHEMATIC DIAGRAM**

– Ref. No.: KY-55 board; 2,000 series –

• **For Printed Wiring Board.**

-  : Uses unleaded solder.
- KY-55 board is four-layer print board. However, the patterns of layers 2 to 3 have not been included in the diagram.
- There are a few cases that the part isn't mounted in this model is printed on this diagram.
- See page 4-46 for printed parts location.

**KY-55 BOARD  
(SIDE A)**

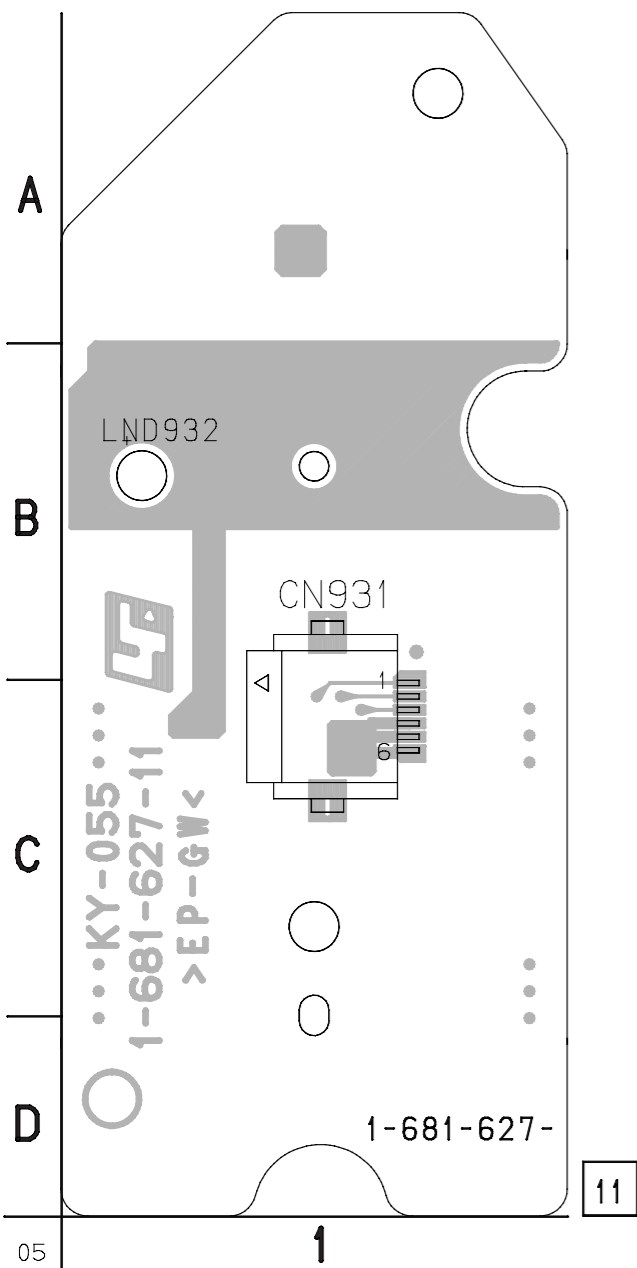

**KY-55 BOARD  
(SIDE B)**

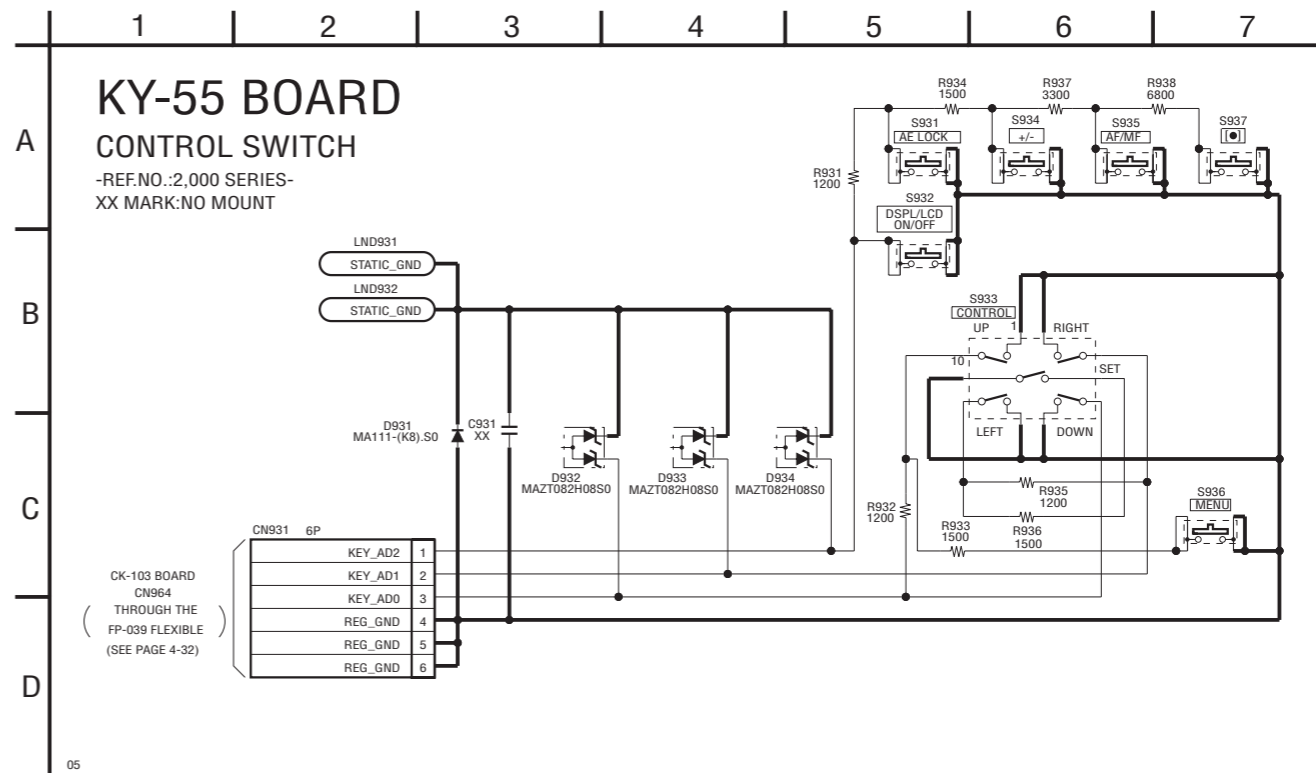
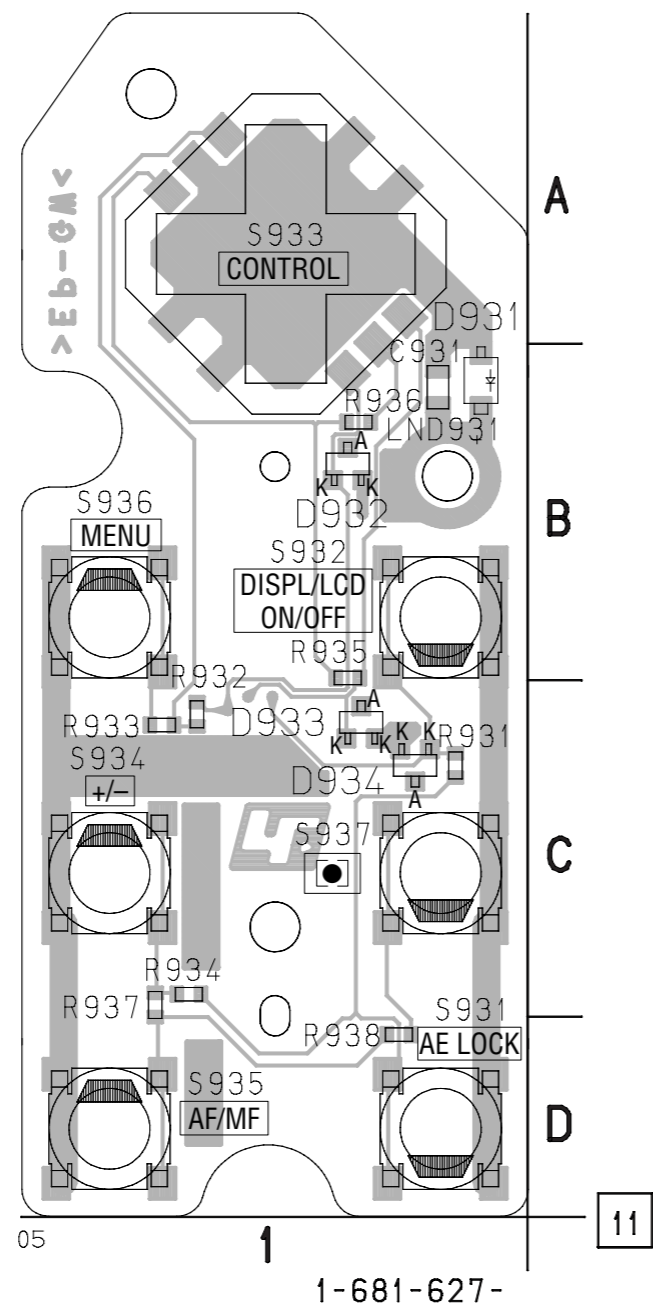

**DM-101 (DC/DC CONVERTER, MS SOCKET) PRINTED WIRING BOARD**

– Ref. No.: DM-101 board; 2,000 series –

• **For Printed Wiring Board.**

-  : Uses unleaded solder.
- DM-101 board is four-layer print board. However, the patterns of layers 2 to 3 have not been included in the diagram.
- There are a few cases that the part isn't mounted in this model is printed on this diagram.
- See page 4-46 for printed parts location.
- Chip parts

Transistor

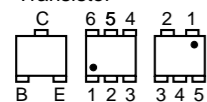

Diode

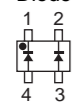

DM-101 BOARD (SIDE A)

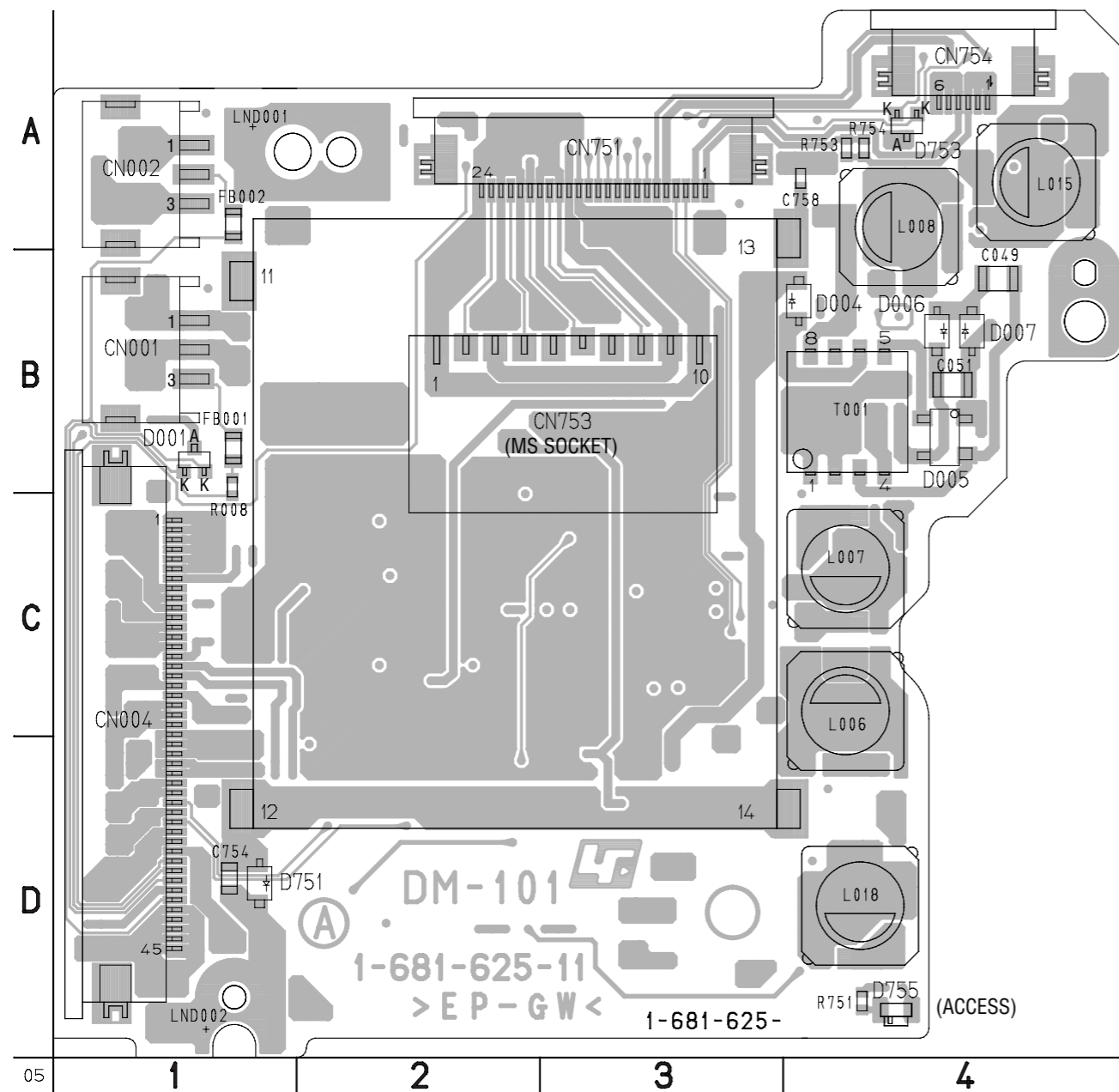

DM-101 BOARD (SIDE B)

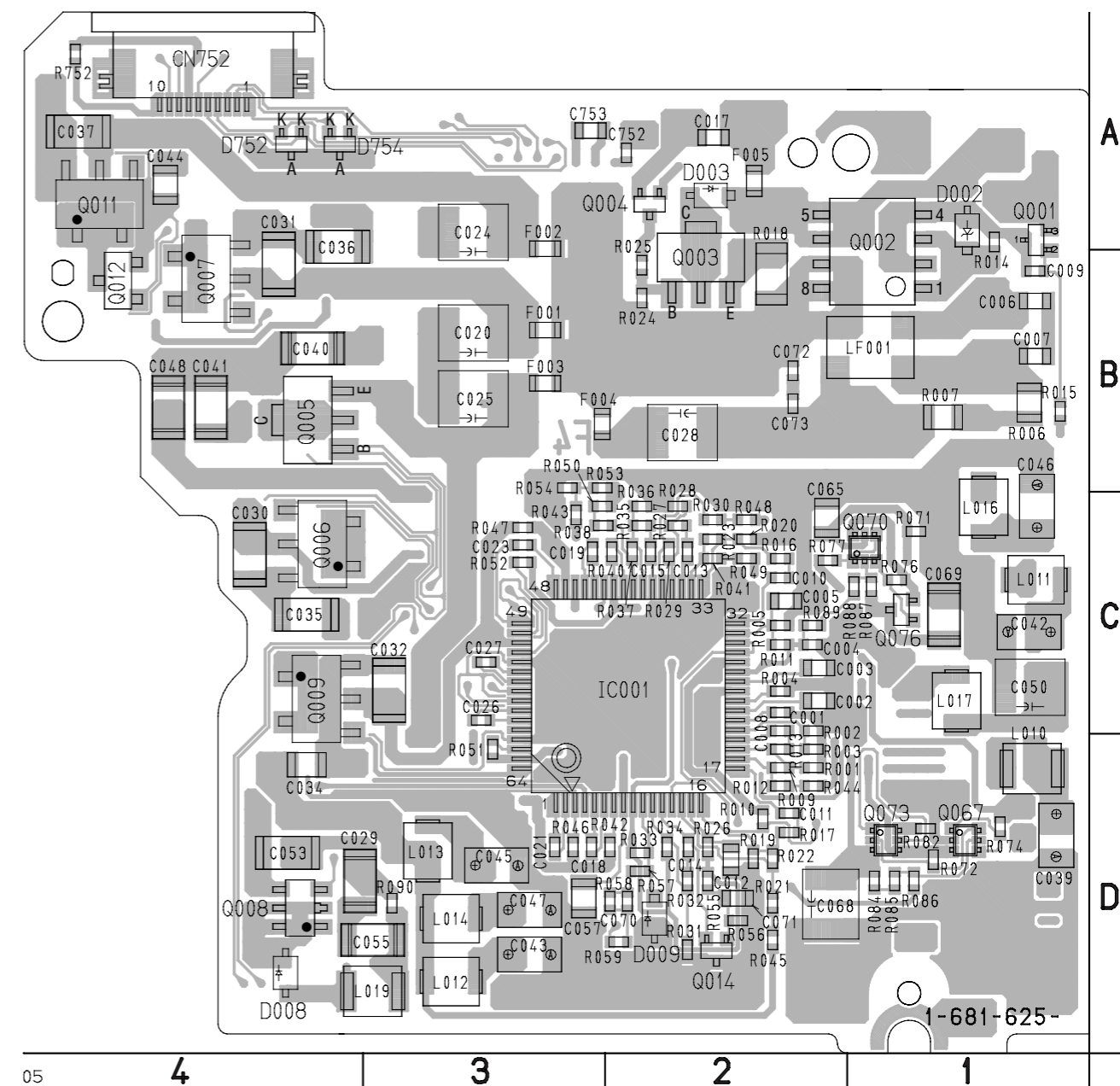

DM-101 (DC/DC CONVERTER) SCHEMATIC DIAGRAM • See page 4-37 for DM-101 printed wiring board.

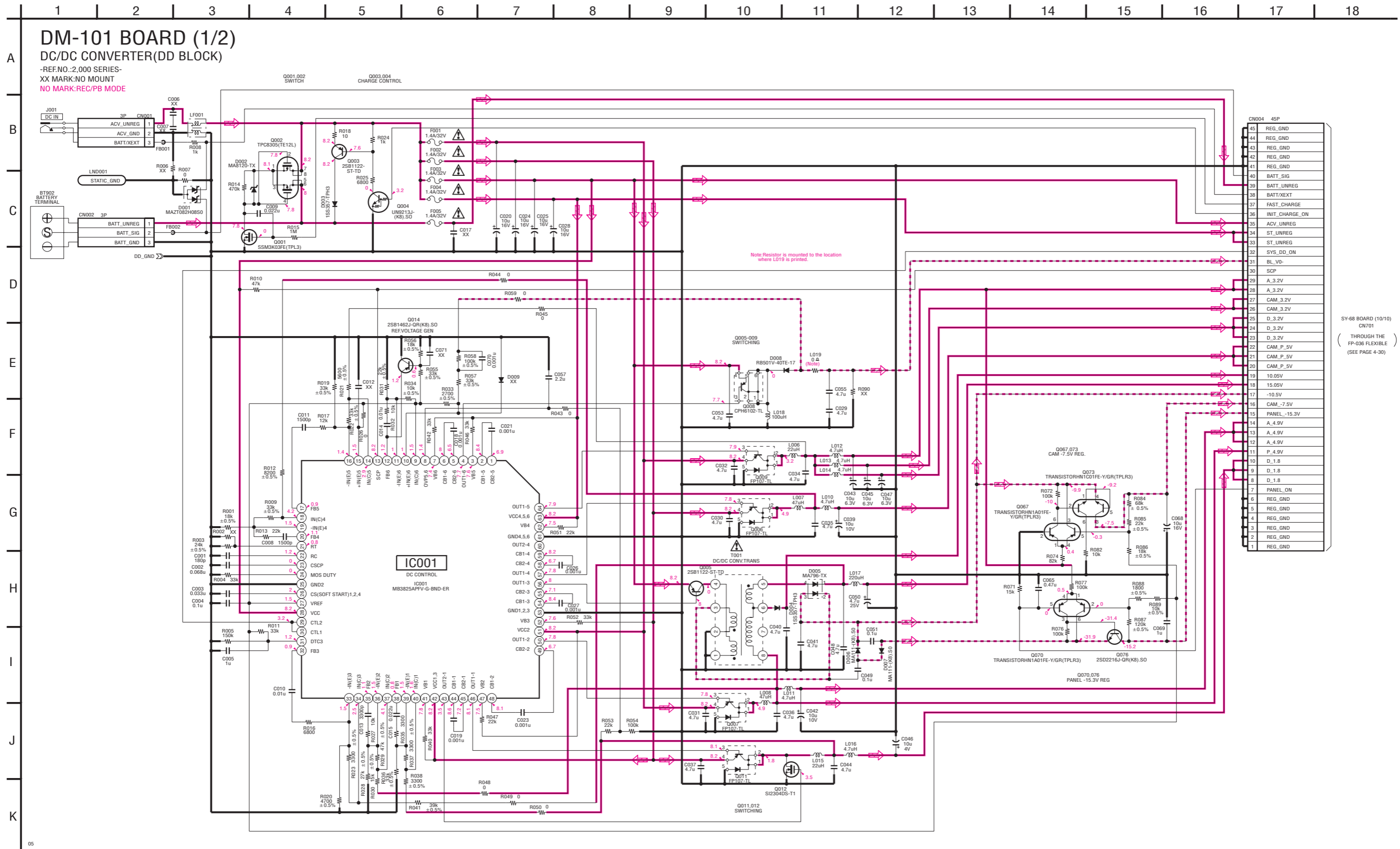

CN004 45P	45	REG_GND
	44	REG_GND
	43	REG_GND
	42	REG_GND
	41	REG_GND
	40	BATT_SIG
	39	BATT_UNREG
	38	BATT/TEXT
	37	FAST_CHARGE
	36	INIT_CHARGE_ON
	35	ACV_UNREG
	34	ST_UNREG
	33	ST_UNREG
	32	SYS_DD_ON
	31	BL_V0
	30	SCP
	29	A_3.2V
	28	A_3.2V
	27	CAM_3.2V
	26	CAM_3.2V
	25	D_3.2V
	24	D_3.2V
	23	D_3.2V
	22	CAM_P_5V
	21	CAM_P_5V
	20	CAM_P_5V
	19	10.05V
	18	15.05V
	17	-10.5V
	16	CAM_-7.5V
	15	PANEL_-15.3V
	14	A_4.9V
	13	A_4.9V
	12	A_4.9V
	11	P_4.9V
	10	D_1.8
	9	D_1.8
	8	D_1.8
	7	PANEL_ON
	6	REG_GND
	5	REG_GND
	4	REG_GND
	3	REG_GND
	2	REG_GND
	1	REG_GND

SY-68 BOARD (10/10)  
 CN701  
 THROUGH THE  
 FP-036 FLEXIBLE  
 (SEE PAGE 4-30)

The components identified by mark  $\Delta$  or dotted line with mark  $\Delta$  are critical for safety. Replace only with part number specified.

Les composants identifiés par une marque  $\Delta$  sont critiques pour la sécurité. Ne les remplacer que par une pièce portant le numéro spécifié.

DM-101 (MS SOCKET) SCHEMATIC DIAGRAM • See page 4-37 for DM-101 printed wiring board.

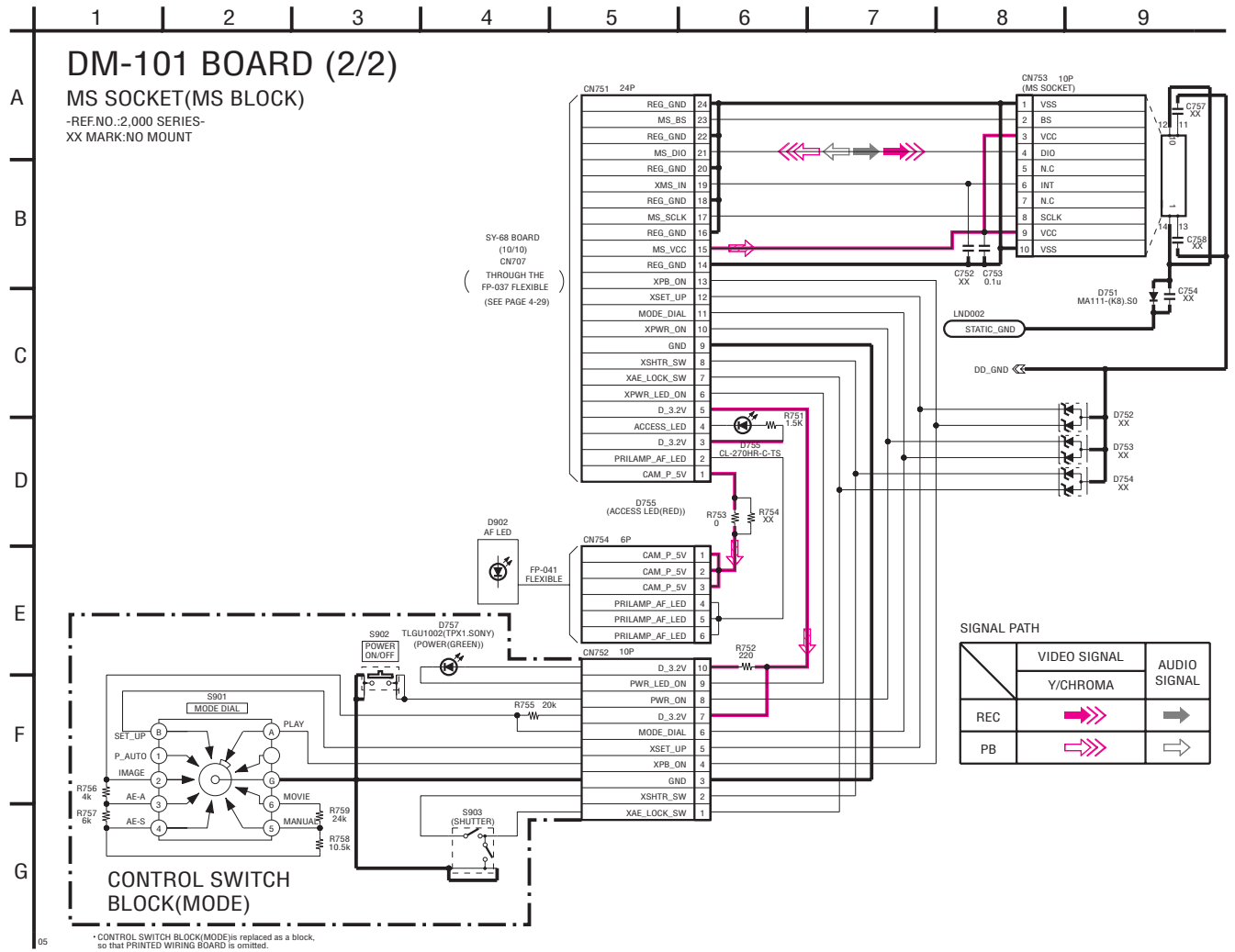

## 4-4. PARTS LOCATION

no mark: SIDE A

\* mark : SIDE B

JK-211 BOARD		KY-55 BOARD		DM-101 BOARD					
BT901	A-1	CN931	C-1	* C001	C-2	* D003	A-2	* R014	A-1
				* C002	C-2	D004	B-4	* R015	B-1
* C901	D-1	* D931	B-1	* C003	C-2	D005	B-4	* R016	C-2
* C903	C-1	* D932	B-1	* C004	C-2	D006	B-4	* R017	D-2
		* D933	C-1	* C005	C-2	D007	B-4	* R018	B-2
CN901	C-1	* D934	C-1	* C008	C-2	* D008	D-4	* R019	D-2
CN902	C-1			* C009	B-1	D751	D-1	* R020	C-2
		* R931	C-1	* C010	C-2	D755	D-4	* R021	D-2
* D901	C-1	* R932	C-1	* C011	D-2			* R022	D-2
* D902	B-1	* R933	C-1	* C013	C-2	* F001	B-3	* R023	C-2
* D903	C-1	* R934	C-1	* C014	D-2	* F002	A-3	* R024	B-2
* D904	B-1	* R935	B-1	* C015	C-2	* F003	B-3	* R025	B-2
* D905	D-1	* R936	B-1	* C018	D-3	* F004	B-3	* R026	D-2
* D906	C-1	* R937	C-1	* C019	C-3	* F005	A-2	* R027	C-2
* D907	B-1	* R938	D-1	* C020	B-3			* R028	C-2
* D908	D-1			* C021	D-3	FB001	B-1	* R029	C-2
* D909	B-1	* S931	D-1	* C023	C-3	FB002	A-1	* R030	C-2
* D910	D-1	* S932	B-1	* C024	A-3			* R031	D-2
* D911	B-1	* S933	A-1	* C025	B-3	* IC001	C-2	* R032	D-2
* D912	C-1	* S934	C-1	* C026	C-3			* R033	D-2
		* S935	D-1	* C027	C-3	L006	C-4	* R034	D-2
* FB901	D-1	* S936	B-1	* C028	B-2	* L010	D-1	* R035	C-2
* FB902	C-1	* S937	C-1	* C029	D-4	* L011	C-1	* R036	C-2
FB903	B-1			* C030	C-4	* L012	D-3	* R037	C-2
FB904	B-1			* C031	B-4	* L013	D-3	* R038	C-3
FB905	B-1			* C032	C-3	* L014	D-3	* R040	C-2
FB906	B-1			* C034	D-4	L015	A-4	* R041	C-2
FB907	B-1			* C035	C-4	* L016	C-1	* R042	D-2
FB908	D-1			* C036	A-4	* L017	C-1	* R043	C-3
FB909	D-1			* C037	A-4	L018	D-4	* R044	D-2
				* C039	D-1	* L019	D-3	* R045	D-2
J901	B-1			* C040	B-4			* R046	D-3
J902	D-1			* C041	B-4	* LF001	B-1	* R047	C-3
				* C042	C-1			* R048	C-2
* LF901	C-1			* C043	D-3	* Q001	A-1	* R049	C-2
				* C044	A-4	* Q002	A-1	* R050	C-3
R901	C-1			* C045	D-3	* Q003	B-2	* R051	D-3
R902	B-1			* C046	C-1	* Q004	A-2	* R052	C-3
* R903	D-1			* C047	D-3	* Q005	B-4	* R053	B-3
R904	C-1			* C048	B-4	* Q006	C-4	* R054	B-3
R905	A-1			C049	B-4	* Q007	B-4	* R055	D-2
* R906	C-1			* C050	C-1	* Q008	D-4	* R056	D-2
* R908	C-1			C051	B-4	* Q009	C-4	* R057	D-2
				* C053	D-4	* Q011	A-4	* R058	D-2
				* C055	D-3	* Q012	B-4	* R059	D-2
				* C057	D-3	* Q014	D-2	* R071	C-1
				* C065	C-2	* Q067	D-1	* R072	D-1
				* C068	D-2	* Q070	C-1	* R074	D-1
				* C069	C-1	* Q073	D-1	* R076	C-1
				* C070	D-2	* Q076	C-1	* R077	C-2
				* C753	A-3			* R082	D-1
				CN001	B-1	* R001	D-2	* R084	D-1
				CN002	A-1	* R003	D-2	* R085	D-1
				CN004	C-1	* R004	C-2	* R086	D-1
				CN751	A-3	* R005	C-2	* R087	C-1
				* CN752	A-4	* R007	B-1	* R088	C-1
				CN753	B-3	R008	B-1	* R089	C-2
				CN754	A-4	* R009	D-2	R751	D-4
						* R010	D-2	* R752	A-4
						* R011	C-2	R753	A-4
				D001	B-1	* R012	D-2		
				* D002	A-1	* R013	D-2	T001	B-4

## SECTION 5 ADJUSTMENTS

### Before starting adjustment

#### EVR Data Re-writing Procedure When Replacing Board

The data that is stored in the repair board, is not necessarily correct.  
Perform either procedure 1 or procedure 2 or procedure 3 when replacing board.

#### Procedure 1

Save the EVR data of the machine in which a board is going to be replaced. Download the saved data after a board is replaced.

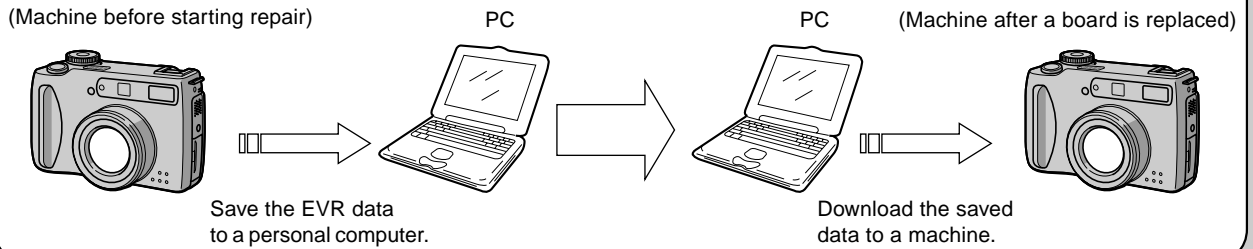

#### Procedure 2

Remove the EEPROM from the board of the machine that is going to be repaired. Install the removed EEPROM to the replaced board.

Remove the EEPROM and install it.

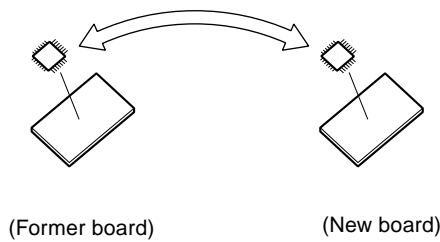

#### Procedure 3

When the data cannot be saved due to defective EEPROM, or when the EEPROM cannot be removed or installed, save the data from the same model of the same destination, and download it.

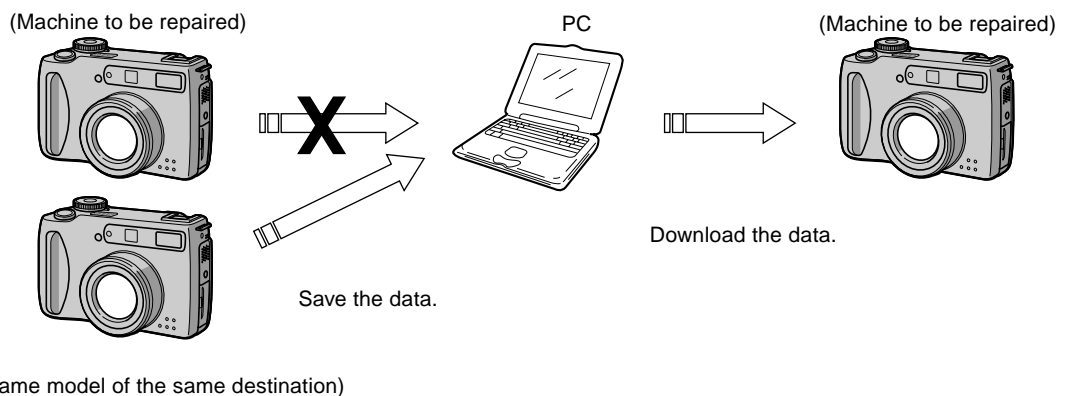

After the EVR data is saved and downloaded, check the respective items of the EVR data.  
(Refer to page 5-2 for the items to be checked.)

### 1-1. Adjusting items when replacing main parts and boards

When replacing main parts and boards, adjust the items indicated by ● in the following table.

Adjustment section	Adjustment	Replaced parts											
		Block replacement				Mounted parts replacement							
		Lens device	Flash unit	LCD block	LCD block	SY-68 board	SY-68 board	SY-68 board	SY-68 board	SY-68 board	SY-68 board		
		LCD901 (LCD panel)	D9001 (Back light unit)	IC151 (CCD imager)	IC102 (S/H, AGC, A/D)	IC505 (EVR)	IC651 (VIDEO AMP)	IC802 (LCD drive)	IC804 (LCD Timing generator)	IC803 (EVR)	SY-68 board (COMPLETE)	SY-68 board	EEPROM
Initialization of 7, 9, B, D, E, F, page data	Initialization of D page data											●	●
	Initialization of 7, 9, B, E, F page data											●	●
Video	Video sync level adj.						●	●				●	●
	Video burst level adj.						●	●				●	●
Camera	Flange back adj.	●				●						●	●
	F No. standard data input	●				●						●	●
	Mechanical shutter adjustment	●				●						●	●
	Light level adj.	●				●	●					●	●
	Mixed color cancel adj.	●				●	●					●	●
	Auto white balance standard data input	●				●	●					●	●
	Auto white balance adj.	●				●	●					●	●
	Color reproduction adj.	●				●	●					●	●
	CCD (white and black) defect compensation					●						●	●
Strobe white balance adj.		●			●	●	●				●	●	
LCD	LCD initial data input											●	●
	VCO adj.									●		●	●
	D range adj.								●			●	●
	Bright adj.								●			●	●
	Contrast adj.								●			●	●
	Color adj.								●			●	●
	V-COM level adj.								●			●	●
	V-COM adj.			●					●			●	●
	White balance adj.			●	●				●			●	●

Table 5-1-1

## 5-1. CAMERA SECTION ADJUSTMENT

### 1-1. PREPARATIONS BEFORE ADJUSTMENT

#### 1-1-1. List of Service Tools

- Oscilloscope
- Color monitor
- Vectorscope
- Regulated power supply
- Digital voltmeter

Ref. No.	Name	Parts Code	Usage
J-1	Filter for color temperature correction (C14)	J-6080-058-A	Auto white balance adjustment/check White balance adjustment/check
J-2	Pattern box PTB-450	J-6082-200-A	
J-3	Color bar chart for pattern box	J-6020-250-A	
J-4	Adjusting remote commander (RM-95 upgraded). (Note 1)	J-6082-053-B	
J-5	Siemens star chart	J-6080-875-A	For checking the flange back
J-6	Clear chart for pattern box	J-6080-621-A	
J-7	CPC-9 jig (Note 2)	J-6082-393-C	For connecting the adjusting remote commander For adjusting the LCD block
J-8	Minipattern box	J-6082-353-B	For adjusting the flange back
J-9	Back ground paper	J-2501-130-A	For adjusting the strobe

**Note 1:** If the micro processor IC in the adjusting remote commander is not the new micro processor (UPD7503G-C56-12), The pages cannot be switched. In this case, replace with the new micro processor (8-759-148-35).

**Note 2:** The old CPC-9 jig (Parts code: J-6082-393-B) cannot be used, because it cannot operate the adjusting remote commander.

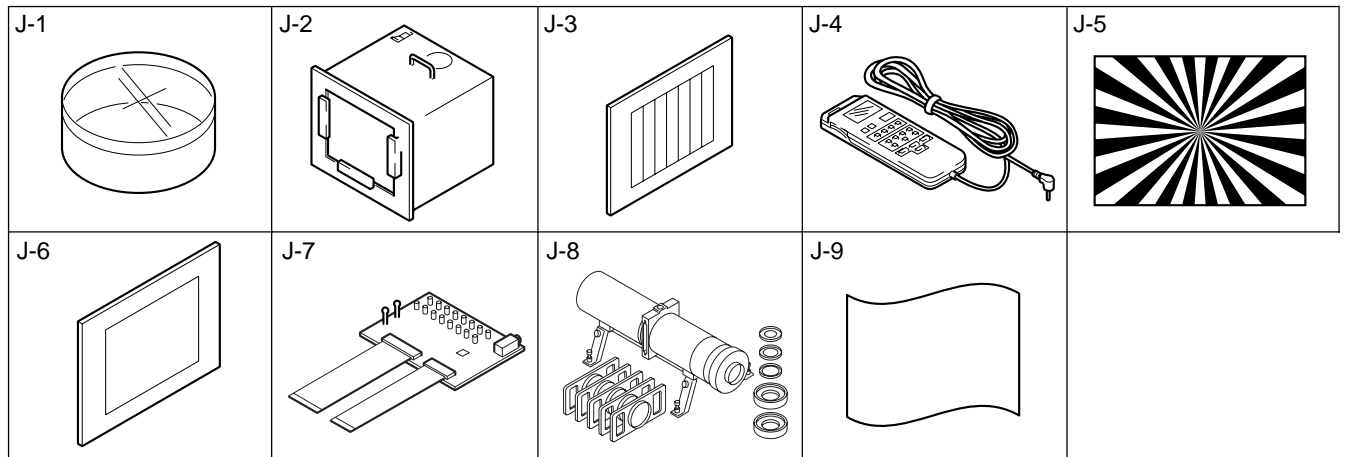

Fig. 5-1-1

### 1-1-2. Preparations

**Note 1:** For details of how remove the cabinet and boards, refer to “2. DISASSEMBLY”.

**Note 2:** When performing only the adjustments, the lens block and boards need not be disassemble.

- 1) Connect the equipment for adjustments according to Fig. 5-1-5.
- 2) Connect the Adjusting remote commander to SY-68 board CN401 via CPC-9 jig (J-6082-393-C). (See Fig. 5-1-3)

**Note 3:** Setting the “Forced CAMERA mode power ON” Mode

- 1) Select page: 0, address: 01, and set data: 01.
- 2) Select page: D, address: 10, set data: 01, and press the PAUSE button of the adjusting remote commander.

The above procedure will enable the camera power to be turned on. After completing adjustments, be sure to exit the “Forced CAMERA mode power ON Mode”.

**Note 4:** Exiting the “Forced CAMERA mode power ON Mode”

- 1) Select page: 0, address: 01, and set data: 01.
- 2) Select page: D, address: 10, set data: 00, and press the PAUSE button of the adjusting remote commander.
- 3) Select page: 0, address: 01, and set data: 00.

### 1-1-3. Discharging of the Flashlight Power Supply

The capacitor which is used as power supply of flashlight is charged with 200 V to 300 V voltage. Discharge this voltage before starting adjustments in order to protect service engineers from electric shock during adjustment.

#### Discharge procedure

1. Press the FLASH button (KY-55 board S933 (CONTROL UP)) and turn off the FLASH LED (SY-68 board D404).
2. Fabricate the discharging jig as shown in Fig. 5-1-5 locally by yourself. Connect the discharging jig to the positive (+) and negative (-) terminal of the flash voltage charge capacitor. Allow ten seconds to discharge the voltage.

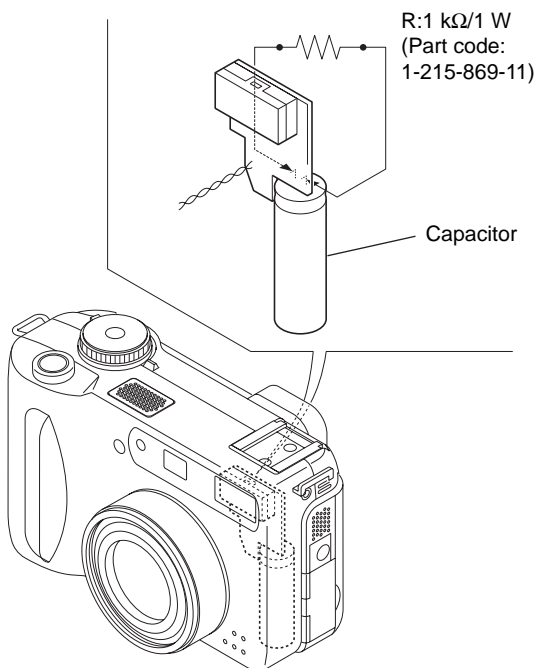

Fig. 5-1-4

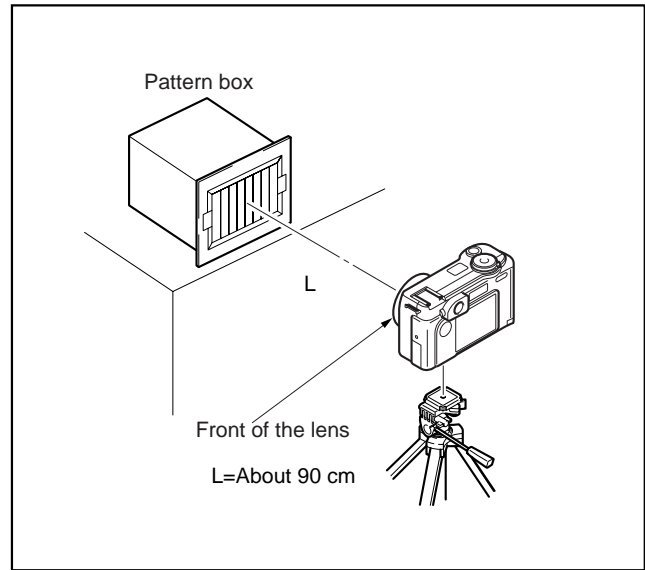
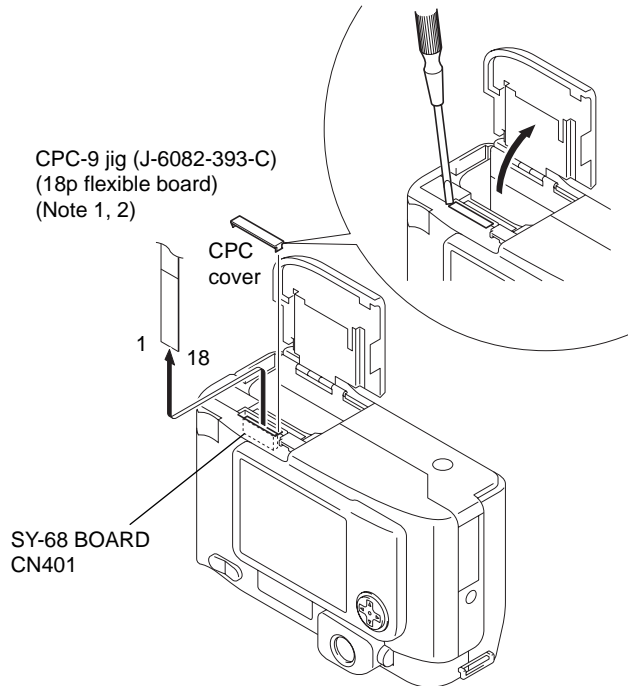

Fig. 5-1-2



**Note 1:** Don t use the 12 pin flexible board of CPC-9 jig. It causes damage to the unit.

**Note 2:** The old CPC-9 jig (Parts code: J-6082-393-B) cannot be used, because it cannot operate the adjusting remote commander.

Fig. 5-1-3

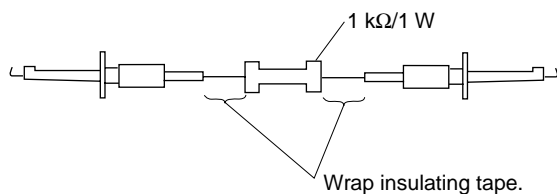

Fig. 5-1-5

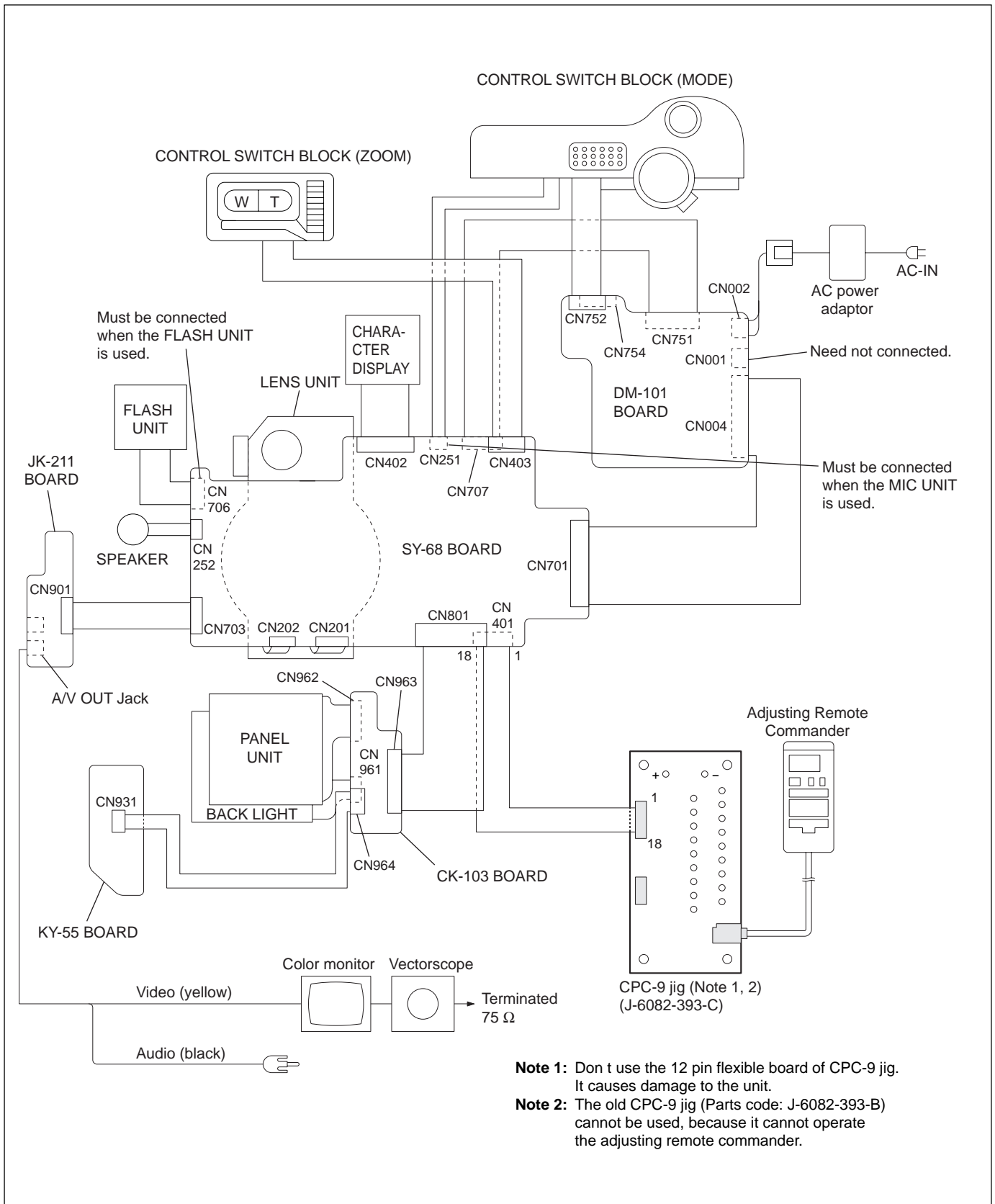

Fig. 5-1-6

### 1-1-4. Precautions

#### 1. Setting the Switch

Unless otherwise specified, set the switches as follows and perform adjustments.

1. PLAY/CAMERA/MOVIE switch  
(Mode Dial) ..... CAMERA
2. FOCUS switch  
(KY-55 board S935) ..... MF (MANUAL FOCUS)
3. EXPOSURE button (KY-55 board S934) 0EV
4. DSPL/LCD ON/OFF button  
(KY-55 board S932) ..... OSD OFF
5. WB (WHITE BALANCE)  
(Menu display) ..... AUTO
6. PEFFECT (Menu display) ..... OFF
7. DEMO (Menu display) ..... OFF
8. VIDEO OUT (Menu display) ..... NTSC

#### 2. Order of Adjustments

Basically carry out adjustments in the order given.

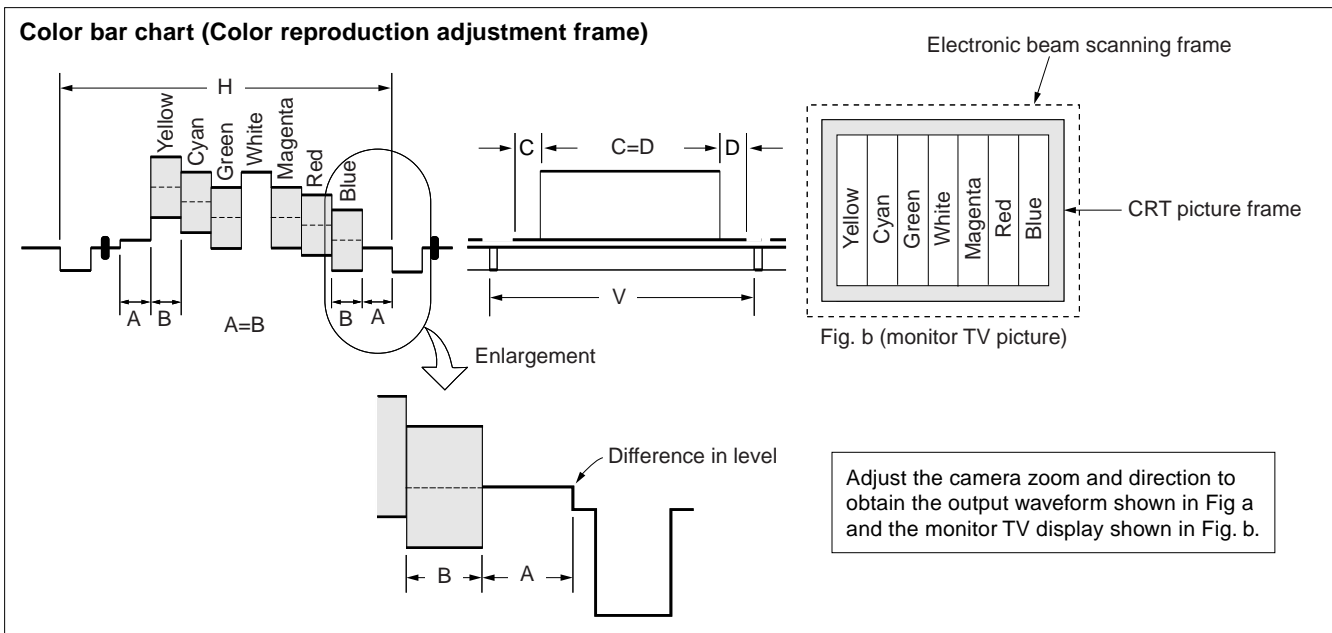

Fig. 5-1-7

### 3. Subjects

- 1) Color bar chart (Standard picture frame).  
When performing adjustments using the color bar chart, adjust the picture frame as shown in Fig. 5-1-7. (Standard picture frame)
- 2) Clear chart (Standard picture frame)  
Remove the color bar chart from the pattern box and insert a clear chart in its place. (Do not perform zoom operations during this time)
- 3) Chart for flange back adjustment  
Join together a piece of white A0 size paper (1189mm × 841 mm) and a piece of black paper to make the chart shown in Fig. 5-1-8.

**Note:** Use a non-reflecting and non-glazing vellum paper. The size must be A0 or larger and the joint between the white and black paper must not have any undulations.

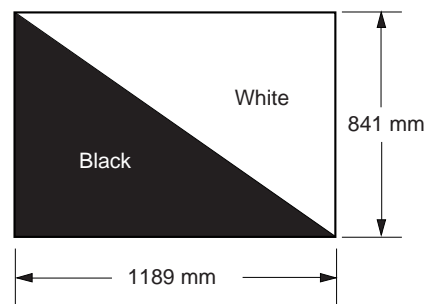
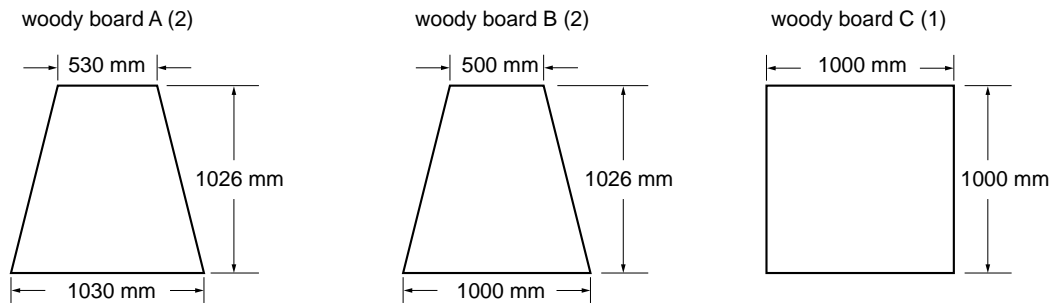

Fig. 5-1-8

#### 4. Preparing the Flash Adjustment Box

A dark room is required to provide an accurate flash adjustment.  
If it is not available, prepare the flash adjustment box as given below;

- 1) Provide woody board A, B and C of 15 mm thickness.



**Fig. 5-1-9**

- 2) Apply black mat paint to one side of woody board A and B.
- 3) Attach background paper (J-2501-130-A) to woody board C.
- 4) Assemble so that the black sides and the background paper side of woody board A, B and C are internal. (Fig 5-1-10)

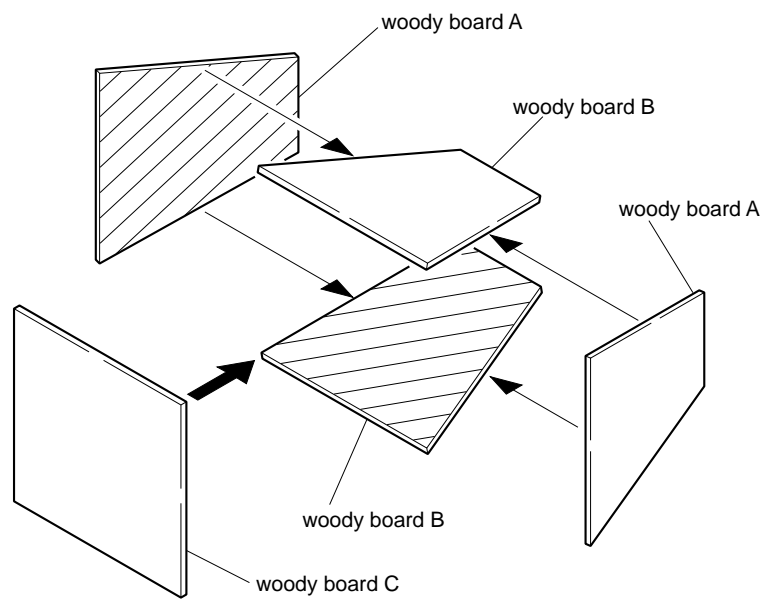

**Fig. 5-1-10**

## 1-2. INITIALIZATION OF B, D, E, F, 7, 9 PAGE DATA

### 1-2-1. Initialization of D Page Data

#### 1. Initializing D Page Data

**Note:** If the D page data has been initialized, the following adjustments need to be performed again.

- 1) Modification of D page data
- 2) LCD system adjustments

Adjusting page	D
Adjusting Address	10 to EF

#### Initializing Method:

Order	Page	Address	Data	Procedure
1	0	01	01	
2	4	03	0B	
3	4	00	2D	
4	4	01	2D	Press PAUSE button.
5	4	02		Check the data changes to "01".
6				Perform "Modification of D page Data".

#### 2. Modification of D Page Data

If the D page data has been initialized, change the data of the "Fixed data-2" address shown in the following table by manual input.

#### Modifying Method:

- 1) Before changing the data, select page: 0, address: 01, and set data: 01.
- 2) New data for changing are not shown in the tables because they are different in destination. When changing the data, copy the data built in the same model.

**Note:** If copy the data built in the different model, the camcorder may not operate.

- 3) When changing the data, press the PAUSE button of the adjusting remote commander each time when setting new data to write the data in the non-volatile memory.
- 4) Check that the data of adjustment addresses is the initial value. If not, change the data to the initial value.

#### Processing after Completing Modification of D Page Data:

Order	Page	Address	Data	Procedure
1	2	00	29	
2	2	01	29	Press PAUSE button.

## 3. D Page Table

**Note 1:** Fixed data-1: Initialized data.

(Refer to "1. Initializing of D Page Data")

**Note 2:** Fixed data-2: Modified data.

(Refer to "2. Modification of D Page Data")

Address	Initial value	Remark
10	00	Test mode
11 to 4E		Fixed data-1 (Initialized data)
4F		Fixed data-2
50 to C5		Fixed data-1 (Initialized data)
C6	5A	Video sync level adj.
C7	61	Video burst level adj.
C8 to CF		Fixed data-1 (Initialized data)
D0	AD	Bright adj.
D1	7E	Color adj.
D2	99	White balance adj.
D3	75	
D4	B7	Contrast adj.
D5	3C	D range adj.
D6	6E	V-COM level adj.
D7	93	VCO adj. (NTSC)
D8	61	V-COM adj.
D9 to DC		Fixed data-1 (Initialized data)
DD	6F	VCO adj. (PAL)
DE		Fixed data-2
DF to EF		Fixed data-1 (Initialized data)

## 1-2-2. Initialization of B, E, F, 7, 9 Page Data

### 1. Initializing B, E, F, 7, 9 Page Data

**Note:** If the B, E, F, 7, 9 Page data has been initialized, “Modification of B, E, F, 7, 9 Page Data” and following adjustments need to be performed again.

- 1) Modification of B, E, F, 7, 9 page data
- 2) Video system adjustments
- 3) Camera system adjustments

Adjusting page	F
Adjusting Address	10 to FF
Adjusting page	E
Adjusting Address	00 to FF
Adjusting page	B
Adjusting Address	00 to FF
Adjusting page	7
Adjusting Address	00 to FF
Adjusting page	9
Adjusting Address	00 to FF

#### Initializing Method:

Order	Page	Address	Data	Procedure
1	0	01	01	
2	6	03	0B	
3	6	00	2D	
4	6	01	2D	Press PAUSE button.
5	6	02		Check the data changes to “01”.
6				Perform “Modification of B, E, F, 7, 9 page Data”.

### 2. Modification of B, E, F, 7, 9 Page Data

If the B, E, F, 7, 9 Page data has been initialized, change the data of the “Fixed data-2” address shown in the following tables by manual input.

#### Modifying Method:

- 1) Before changing the data, select page: 0, address: 01, and set data: 01.
- 2) New data for changing are not shown in the tables because they are different in destination. When changing the data, copy the data built in the same model.  
**Note:** If copy the data built in the different model, the camcorder may not operate.
- 3) When changing the data, press the PAUSE button of the adjusting remote commander each time when setting new data to write the data in the non-volatile memory.
- 4) Check that the data of adjustment addresses is the initial value. If not, change the data to the initial value.

#### Processing after Completing Modification of B, E, F, 7, 9 Page data

Order	Page	Address	Data	Procedure
1	2	00	29	
2	2	01	29	Press PAUSE button.

### 3. B Page Table

**Note 1:** Fixed data-1: Initialized data.

(Refer to “1. Initializing B, E, F, 7, 9 Page Data”)

**Note 2:** Fixed data-2: Modified data.

(Refer to “2. Modification of B, E, F, 7, 9 Page Data”)

Address	Initial value	Remark
00 to FF		Fixed data-1 (Initialized data)

### 4. E Page Table

**Note 1:** Fixed data-1: Initialized data.

(Refer to “1. Initializing B, E, F, 7, 9 Page Data”)

**Note 2:** Fixed data-2: Modified data.

(Refer to “2. Modification of B, E, F, 7, 9 Page Data”)

Address	Initial value	Remark
00 to FF		Fixed data-1 (Initialized data)

## 5. F Page Table

**Note 1:** Fixed data-1: Initialized data. (Refer to “1.Initializing of B, E, F, 7, 9 Page Data”)

**Note 2:** Fixed data-2: Modified data. (Refer to “2.Modification of B, E, F, 7, 9 Page Data”)

Address	Initial value	Remark
10 to 13	Fixed data-1 (Initialized data)	
14	33	Flange back adj.
15	48	
16	DA	
17	DF	
18	13	
19	C0	
1A	00	
1B	00	
1C	00	
1D	00	
1E	00	
1F	00	
20	20	
21	20	
22	BA	
23	46	
24	0A	
25	00	
26	85	Light level adj.
27	B0	
28	94	
29	00	F No. standard data input
2A	00	
2B	00	
2C	00	
2D	00	
2E to 39	Fixed data-1 (Initialized data)	
3A	2F	Auto white balance standard data input
3B	37	
3C	40	
3D	D0	
3E	Fixed data-1 (Initialized data)	
3F	B5	Auto white balance adj.
40	43	Color reproduction adj.
41	03	
42	E9	
43	63	
44	83	
45	D5	
46	FE	
47	73	
48	45	
49 to 4C	Fixed data-1 (Initialized data)	
4D	28	Strobe white balance adj.
4E	6E	
4F to 58	Fixed data-1 (Initialized data)	

Address	Initial value	Remark
59	00	Auto white balance standard data input
5A	14	Mechanical shutter adj.
5B	Fixed data-1 (Initialized data)	
5C	63	Color reproduction adj.
5D	83	
5E	03	
5F	E9	
60 to 63	Fixed data-1 (Initialized data)	
64	10	Strobe white balance adj.
65 to 68	Fixed data-1 (Initialized data)	
69	00	Strobe white balance adj.
6A	C0	
6B	B4	Mechanical shutter adj.
6C	10	
6D	05	
6E	09	
6F	B5	
70	07	
71	C4	
72	07	
73	48	
74	06	
75	CB	
76	01	
77	01	
78	01	
79	01	
7A	01	
7B	2C	
7C	3A	
7D	2E	
7E	2D	
7F	2D	
80	00	Auto white balance adj.
81 to 86	Fixed data-1 (Initialized data)	
87	FF	Flange back adj.
88	00	
89	00	
8A	00	
8B	00	
8C	00	
8D	00	
8E	00	
8F	00	
90	00	
91	00	
92	00	

Address	Initial value	Remark
93	00	Flange back adj.
94	00	
95	00	
96	00	
97	00	
98	00	
99	00	
9A	00	
9B	00	
9C to 9F	Fixed data-1 (Initialized data)	
A0	00	Mixed color cancel adj.
A1	00	
A2	00	
A3	00	
A4 to A8	Fixed data-1 (Initialized data)	
A9	0F	Auto white balance adj.
AA	05	
AB to D3	Fixed data-1 (Initialized data)	
D4	80	Mechanical shutter adj.
D5	8A	
D6	8A	
D7	8A	
D8	8A	
D9 to FF	Fixed data-1 (Initialized data)	

**6. 7 Page Table**

**Note 1:** Fixed data-1: Initialized data. (Refer to “1. Initializing B, E, F, 7, 9 Page Data”)

**Note 2:** Fixed data-2: Modified data. (Refer to “2. Modification of B, E, F, 7, 9 Page Data”)

Address	Initial value	Remark
00 to 5F	Fixed data-1 (Initialized data)	
60	0F	CCD black defect compensation
61	FF	
62	0F	
63	FF	
64	0F	
65	FF	
66	0F	
67	FF	
68	0F	
69	FF	
6A	0F	
6B	FF	
6C	0F	
6D	FF	
6E	0F	
6F	FF	
70	0F	
71	FF	
72	0F	
73	FF	
74	0F	
75	FF	
76	0F	
77	FF	
78	0F	
79	FF	
7A	0F	
7B	FF	
7C	0F	
7D	FF	
7E	0F	
7F	FF	
80	0F	
81	FF	
82	0F	
83	FF	
84	0F	
85	FF	
86	0F	
87	FF	
88	0F	
89	FF	
8A	0F	
8B	FF	
8C	0F	
8D	FF	
		CCD white defect compensation

Address	Initial value	Remark
8E	0F	CCD white defect compensation
8F	FF	
90	0F	
91	FF	
92	0F	
93	FF	
94	0F	
95	FF	
96	0F	
97	FF	
98	0F	
99	FF	
9A	0F	
9B	FF	
9C	0F	
9D	FF	
9E	0F	
9F	FF	
A0	0F	
A1	FF	
A2	0F	
A3	FF	
A4 to FF	Fixed data-1 (Initialized data)	

**7. 9 Page Table**

**Note 1:** Fixed data-1: Initialized data.

(Refer to “1. Initializing B, E, F, 7, 9 Page Data”)

**Note 2:** Fixed data-2: Modified data.

(Refer to “2. Modification of B, E, F, 7, 9 Page Data”)

Address	Initial value	Remark
00 to FF	Fixed data-1 (Initialized data)	

### 1-3. VIDEO SYSTEM ADJUSTMENTS

#### 1. Video Sync Level Adjustment

Adjust the sync level of the composite video signal output.

Mode	PLAY
Signal	Arbitrary
Measurement Point	Video terminal of A/V OUT jack (75 Ω terminated)
Measuring Instrument	Oscilloscope
Adjustment Page	D
Adjustment Address	C6
Specified Value	A = 286 ± 5 mVp-p (NTSC) A = 300 ± 5 mVp-p (PAL)

#### Adjusting method:

Order	Page	Address	Data	Procedure
1	0	01	01	
2	4	F1	04	
3	D	C6		Change the data and set the sync level (A) to the specified value.
4	D	C6		Press PAUSE button

#### Processing after Completing Adjustments:

Order	Page	Address	Data	Procedure
1	4	F1	00	
2	0	01	00	

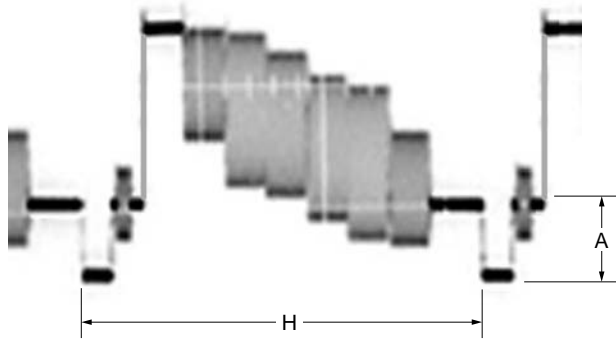

Fig. 5-1-11

#### 2. Video Burst Level Adjustment

Adjust the burst level of the composite video signal output.

Mode	PLAY
Signal	Arbitrary
Measurement Point	Video terminal of A/V OUT jack (75 Ω terminated)
Measuring Instrument	Oscilloscope
Adjustment Page	D
Adjustment Address	C7
Specified Value	A = 286 ± 5 mVp-p (NTSC) A = 300 ± 5 mVp-p (PAL)

#### Adjusting method:

Order	Page	Address	Data	Procedure
1	0	01	01	
2	4	F1	04	
3	D	C7		Change the data and set the burst level (A) to the specified value.
4	D	C7		Press PAUSE button

#### Processing after Completing Adjustments:

Order	Page	Address	Data	Procedure
1	4	F1	00	
2	0	01	00	

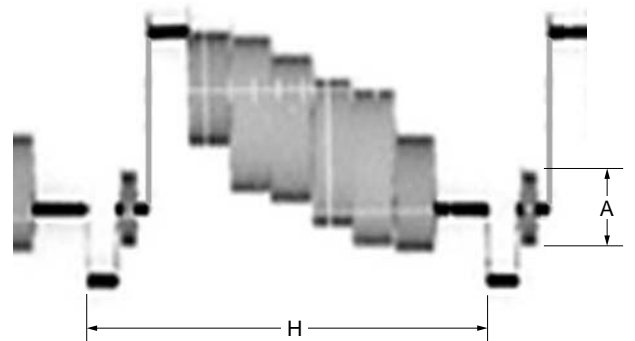

Fig. 5-1-12

**1-4. CAMERA SYSTEM ADJUSTMENTS**

Before perform the camera system adjustments, check that the specified values of “VIDEO SYSTEM ADJUSTMENTS” are satisfied.

**Note:** For “CAMERA SYSTEM ADJUSTMENTS”, perform in order of item numbers.

**Data setting during camera system adjustments**

Perform the following data setting before the camera system adjustments.

**Menu setting:**

- 1) VIDEO OUT of SET UP menu..... NTSC (NTSC mode)  
(This adjustment must be performed in NTSC mode, so don't set the menu setting to “PAL”)

**Data setting method:**

Order	Page	Address	Data	Procedure
1	0	01	01	
2	D	10	80	Press PAUSE button.
3	2	10		Check the bit values of bit3, bit4 and bit5 are “1”. (Note 1, 2)
4	D	11	40	Press PAUSE button.
5	D	10	81	Press PAUSE button.
5	6	C1		Check the data changes to “02”.
6	4	06	01	
7	6	6C	01	
8				Wait for 1 second.
9	B	75	00	Press PAUSE button.

**Note 1:** For the bit values, refer to “5-2. SERVICE MODE”, “2-3. 2. Bit value discrimination”.

**Note 2:** In case of wrong data, select page: 2, address: 0A and set data: 02.

Set the adjusting remote commander to normal LANC, and the power will be turned off and on automatically. Wait for more than 0.167 second after the power on, and set the adjusting remote commander to the service LANC. Then, retry from the step 1.

**Note 3:** Repeat the “Data setting method”, if the power was turned off and on during the “CAMERA SYSTEM ADJUSTMENTS”.

**After completing the camera system adjustments, release the data setting:**

Order	Page	Address	Data	Procedure
1	4	06	00	
2	6	6C	00	
3	B	75	10	Press PAUSE button.
4	D	11	00	Press PAUSE button.
5	D	10	00	Press PAUSE button.
6	0	01	00	

### 1. Flange Back Adjustment (Using the minipattern box)

The flange back of inner focus lens is adjusted automatically. If shifted, the auto focus is disordered.

Mode	CAMERA
Subject	Siemens star chart with ND filter for minipattern box (Note 1)
Measurement Point	Check operation on the LCD screen
Measuring Instrument	
Adjustment Page	F
Adjustment Address	14 to 25, 87 to 9B

**Note 1:** Dark Siemens star chart.

**Note 2:** Check that the data of page: 6, address: 02 is "00".  
If not, turn the power of unit OFF/ON.

#### Preparations before adjustments:

1) The minipattern box is installed as shown in the following figure.

**Note 3:** The attachment lenses are not used.

**Note 4:** Take care not to hit the mini-pattern box when extending the lens.

- Install the minipattern box so that the distance between it and the front of lens of camera is less than 3 cm.
- Make the height of minipattern box and the camera equal.
- Check the output voltage of the regulated power supply is the specified voltage  $\pm 0.01$  Vdc.
- Check that the center of Siemens star chart meets the center of shot image screen with the zoom lens at TELE end and WIDE end respectively.
- Check that the data on page: F, address: 14 to 25 and 87 to 9B are initial value (See table below).

Address	Data	Address	Data	Address	Data
14	33	21	20	8F	00
15	48	22	BA	90	00
16	DA	23	46	91	00
17	DF	24	0A	92	00
18	13	25	00	93	00
19	C0	87	FF	94	00
1A	00	88	00	95	00
1B	00	89	00	96	00
1C	00	8A	00	97	00
1D	00	8B	00	98	00
1E	00	8C	00	99	00
1F	00	8D	00	9A	00
20	20	8E	00	9B	00

Specified voltage: The specified voltage varies according to the minipattern box, so adjustment the power supply output voltage to the specified voltage written on the sheet which is supplied with the minipattern box.

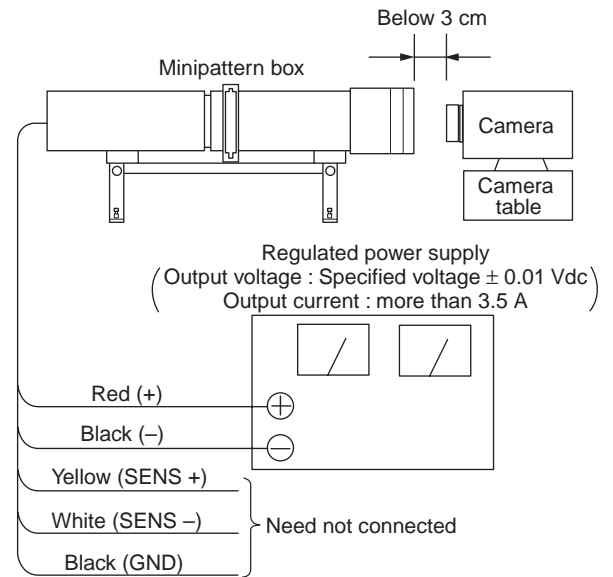

**Fig. 5-1-13**

#### Adjusting method:

Order	Page	Address	Data	Procedure
1	0	01	01	
2				Perform "Data setting during camera system adjustments". (Refer to page 5-14)
3	6	01	13	Press PAUSE button.
4	6	01	27	Press PAUSE button. (Note 5)
5	6	02		Check the data changes to "01".
6	F	87		Check the data changes to "00".

**Note 5:** The adjustment data will be automatically input to page: F, address: 14 to 25 and 87 to 9B.

#### Processing after Completing Adjustment:

Order	Page	Address	Data	Procedure
1	6	01	00	Press PAUSE button.
2				Release the data setting performed at step 2. (Refer to page 5-14)
3	0	01	00	
4				Perform "Flange Back Check".

## 2. Flange Back Adjustment (Using the flange back adjustment chart)

The flange back of inner focus lens is adjusted automatically. If shifted, the auto focus is disordered.

Mode	CAMERA
Subject	Flange back adjustment chart (2.0 m from the front of the lens) (Luminance: 300 to 400 lux)
Measurement Point	Check operation on the LCD screen
Measuring Instrument	
Adjustment Page	F
Adjustment Address	14 to 25, 87 to 9B

**Note 1:** Check that the data of page: 6, address: 02 is "00".  
If not, turn the power of unit OFF/ON.

### Preparations before adjustments:

- 1) Place the Flange back adjustment chart 2.0 m from the front of the lens.
- 2) Check that the center of Flange back adjustment chart meets the center of shot image screen with the zoom lens at TELE end and WIDE end respectively.
- 3) Check that the data on page: F, address: 14 to 25 and 87 to 9B are initial value (See table below).

Address	Data	Address	Data	Address	Data
14	33	21	20	8F	00
15	48	22	BA	90	00
16	DA	23	46	91	00
17	DF	24	0A	92	00
18	13	25	00	93	00
19	C0	87	FF	94	00
1A	00	88	00	95	00
1B	00	89	00	96	00
1C	00	8A	00	97	00
1D	00	8B	00	98	00
1E	00	8C	00	99	00
1F	00	8D	00	9A	00
20	20	8E	00	9B	00

### Adjusting method:

Order	Page	Address	Data	Procedure
1	0	01	01	
2				Perform "Data setting during camera system adjustments". (Refer to page 5-14)
3	6	01	13	Press PAUSE button.
4	6	01	15	Press PAUSE button. (Note 2)
5	6	02		Check the data changes to "01".
6	F	87		Check the data changes to "00".

**Note 2:** The adjustment data will be automatically input to page: F, address: 14 to 25 and 87 to 9B.

### Processing after Completing Adjustment:

Order	Page	Address	Data	Procedure
1	6	01	00	Press PAUSE button.
2				Release the data setting performed at step 2. (Refer to page 5-14)
3	0	01	00	
4				Perform "Flange Back Check".

### 3. Flange Back Check

Mode	CAMERA
Subject	Siemens star chart (1.0 m from the front of the lens) (Luminance: 200 to 400 lux)
Measurement Point	Check operation on the LCD screen
Measuring Instrument	
Specified value	Focused at the TELE end and WIDE end

#### Checking method:

Order	Page	Address	Data	Procedure
1				Place the Siemens star 1.0 m from the front of the lens. To open the IRIS , decrease the luminous intensity to the Siemens star up to a point before noise appear on the image.
2	0	01	01	
3				Perform “Data setting during camera system adjustments”. (Refer to page 5-14)
4				Shoot the Siemens star chart with the zoom TELE end. At this time, the center of Siemens star chart should be in the center of the LCD screen.
5				Check that the lens is focused.
6	6	2C	01	
7				While observe the LCD screen, change the zoom to the WIDE end and check that the lens is focused.

#### Processing after Completing Adjustment:

Order	Page	Address	Data	Procedure
1	6	2C	00	
2				Release the data setting performed at step 3. (Refer to page 5-14)
3	0	01	00	

#### 4. Picture Frame Setting

Mode	CAMERA
Subject	Color bar chart (Color reproduction adjustment frame with the zoom lens at WIDE end)
Measurement Point	Video terminal of A/V OUT jack (75 Ω terminated)
Measuring Instrument	Oscilloscope and TV monitor
Specified Value	A=B, C=D, E=F

**Note 1:** Displayed data of the page 1 of adjusting remote commander.

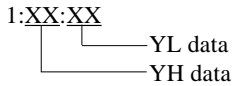

#### Switch setting:

- 1) FOCUS ..... AF (AUTO FOCUS)

#### Setting method:

Order	Page	Address	Data	Procedure
1	0	01	01	
2				Perform "Data setting during camera system adjustments". (Refer to page 5-14)
3				Shoot the color bar chart with the zoom WIDE end.
4				Enter the output of VIDEO OUT to the TV monitor, and move to the position as shown in Fig. 5-1-16.
5				Horizontal width of one color (B, C) and that of black (A, D) on the color bar chart should be same. (See Fig. 5-1-14)
6				With vertical width of black (E, F) set in same, the color bar chart should come to the center of TV monitor. (See Fig. 5-1-15)
7				Check that the color bar on the TV monitor is focused.
8	0	03	22	
9	1			Note down the YH and YL data. (Note 1)

#### Processing after Completing Adjustment:

Order	Page	Address	Data	Procedure
1	0	03	00	
2				Release the data setting performed at step 2. (Refer to page 5-14)
3	0	01	00	

#### How to reset the zoom and focus when they deviated:

Order	Page	Address	Data	Procedure
1	6	2C	01	
2	6	90	00	
3	6	91	00	
4	6	92	YL	(Note 2)
5	6	93	YH	(Note 2)
6	6	01	79	Press PAUSE button.
7	6	07		Check the data changes to "01".
8	6	01	00	Press PAUSE button.

**Note 2:** The data noted down at step 9 of "Setting method".

#### Check on the oscilloscope

##### 1. Horizontal period

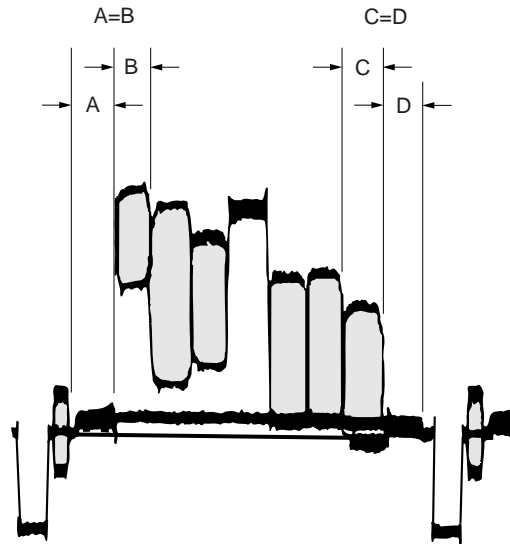

Fig. 5-1-14

##### 2. Vertical period

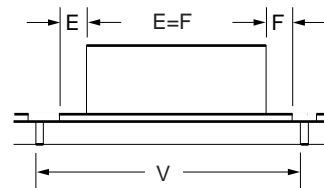

Fig. 5-1-15

#### Check on the TV monitor

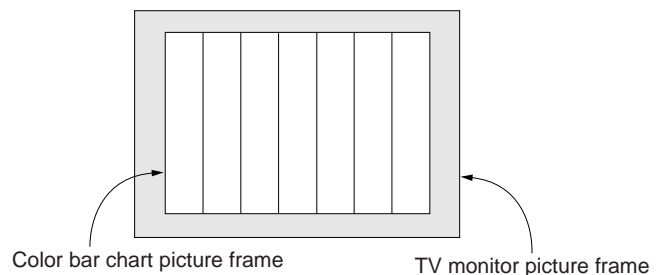

Fig. 5-1-16

### 5. F No. Standard Data Input

Compensate the unevenness of the iris meter sensitivity.

Mode	CAMERA
Subject	Clear chart (Color reproduction adjustment frame with the zoom lens at WIDE end)
Adjustment Page	F
Adjustment Address	29 to 2D

**Note 1:** Check that the data of page: 6, address: 02 is "00".

If not, turn the power of unit OFF/ON.

**Note 2:** Refer to "Picture Frame Setting" for YH and YL.

#### Adjusting method:

Order	Page	Address	Data	Procedure
1	0	01	01	
2				Perform "Data setting during camera system adjustments". (Refer to page 5-14)
3	6	2C	01	
4	6	90	00	
5	6	91	00	
6	6	92	YL	(Note 2)
7	6	93	YH	(Note 2)
8	6	01	79	Press PAUSE button.
9	6	07		Check the data changes to "01".
10	6	01	00	Press PAUSE button.
11	6	01	BB	Press PAUSE button. (Note 3)
12	6	02		Check the data changes to "01".

**Note 3:** The adjustment data will be automatically input to page: F, address: 29 to 2D.

#### Processing after Completing Adjustment:

Order	Page	Address	Data	Procedure
1	6	01	00	Press PAUSE button.
2	6	2C	00	
3	6	92	00	
4	6	93	00	
5				Release the data setting performed at step 2 . (Refer to page 5-14)
6	0	01	00	

### 6. Mechanical Shutter Adjustment

Adjust the period which the mechanical shutter is closed, and compensate the exposure.

Mode	CAMERA
Subject	Clear chart (Color reproduction adjustment frame with the zoom lens at WIDE end)
Adjustment Page	F
Adjustment Address	5A, 6C to 7F, D4 to D8

**Note 1:** Check that the data of page: 6, address: 02 is "00".

If not, turn the power of unit OFF/ON.

**Note 2:** Refer to "Picture Frame Setting" for YH and YL.

#### Adjusting method:

Order	Page	Address	Data	Procedure
1	0	01	01	
2				Perform "Data setting during camera system adjustments". (Refer to page 5-14)
3	6	2C	01	
4	6	90	00	
5	6	91	00	
6	6	92	YL	(Note 2)
7	6	93	YH	(Note 2)
8	6	01	79	Press PAUSE button.
9	6	07		Check the data changes to "01".
10	6	01	00	Press PAUSE button.
11	6	01	AD	Press PAUSE button. (Note 3)
12	6	02		Check the data changes to "01".
13	6	AB		Check the data changes to "00".

**Note 3:** The adjustment data will be automatically input to page: F, address: 5A, 6C to 7F and D4 to D8.

#### Processing after Completing Adjustment:

Order	Page	Address	Data	Procedure
1	6	01	00	Press PAUSE button.
2	6	2C	00	
3	6	92	00	
4	6	93	00	
5				Release the data setting performed at step 2 . (Refer to page 5-14)
6	0	01	00	

### 7. Light Level Adjustment

Adjust the standard LV value.

Mode	CAMERA
Subject	Clear chart (Color reproduction adjustment frame with the zoom lens at WIDE end)
Measurement Point	Displayed data of page: 1 (Note 3)
Measuring Instrument	Adjusting remote commander
Adjustment Page	F
Adjustment Address	26 to 28
Specified Value	AE level: 0FC0 to 1040

**Note 1:** Check that the data of page: 6, address: 02 is "00".  
If not, turn the power of the unit OFF/ON.

**Note 2:** Refer to "Picture Frame Setting" for YH and YL.

**Note 3:** The right 4 digits of the page: 1 displayed data of the adjusting remote commander.

1:XX:XX

└───Displayed data

#### Adjusting method:

Order	Page	Address	Data	Procedure
1	0	01	01	
2				Perform "Data setting during camera system adjustments". (Refer to page 5-14)
3	6	2C	01	
4	6	90	00	
5	6	91	00	
6	6	92	YL	(Note 2)
7	6	93	YH	(Note 2)
8	6	01	79	Press PAUSE button.
9	6	07		Check the data changes to "01".
10	6	01	00	Press PAUSE button.
11	6	01	0D	Press PAUSE button. (Note 4)
12	6	02		Check the data changes to "01".
13	0	03	06	
14	1			Check that the displayed data (Note 3) satisfies the AE level specified value.

**Note 4:** The adjustment data will be automatically input to page: F, address: 26 to 28.

#### Processing after Completing Adjustment:

Order	Page	Address	Data	Procedure
1	0	03	00	
2	6	01	00	Press PAUSE button.
3	6	2C	00	
4	6	92	00	
5	6	93	00	
6				Release the data setting performed at step 2. (Refer to page 5-14)
7	0	01	00	

### 8. Mixed Color Cancel Adjustment

To perform mixed color cancel adjustment based on data of each color in color bar.

Mode	CAMERA
Subject	Color bar chart (Color reproduction adjustment frame with the zoom lens at WIDE end)
Adjustment Page	F
Adjustment Address	A0 to A3

**Note 1:** Check that the data of page: 6, address: 02 is "00".  
If not, turn the power of the unit OFF/ON.

**Note 2:** Refer to "Picture Frame Setting" for YH and YL.

#### Adjusting method:

Order	Page	Address	Data	Procedure
1	0	01	01	
2				Perform "Data setting during camera system adjustments". (Refer to page 5-14)
3	6	2C	01	
4	6	90	00	
5	6	91	00	
6	6	92	YL	(Note 2)
7	6	93	YH	(Note 2)
8	6	01	79	Press PAUSE button.
9	6	07		Check the data changes to "01".
10	6	01	00	Press PAUSE button.
11	6	01	D7	Press PAUSE button.
12	6	01	D5	Press PAUSE button. (Note 3)
13	6	02		Check the data changes to "01".

**Note 3:** The adjustment data will be automatically input to page: F, address: A0 to A3.

#### Processing after Completing Adjustment:

Order	Page	Address	Data	Procedure
1	6	01	00	Press PAUSE button.
2	6	2C	00	
3	6	92	00	
4	6	93	00	
5				Release the data setting performed at step 2. (Refer to page 5-14)
6	0	01	00	

### 9. Auto White Balance Standard Data Input

Adjust the white balance standard data at 3200K.

Mode	CAMERA
Subject	Clear chart (Color reproduction adjustment frame with the zoom lens at WIDE end)
Adjustment Page	F
Adjustment Address	3A to 3D, 59

**Note 1:** Check that the data of page: 6, address: 02 is "00".

If not, turn the power of unit OFF/ON.

**Note 2:** Refer to "Picture Frame Setting" for YH and YL.

**Note 3:** "Auto White Balance Standard Data Input" is available only once after the power is turned on. Turn the power off, then on again if the adjustment is retried.

#### Adjusting method:

Order	Page	Address	Data	Procedure
1	0	01	01	
2				Perform "Data setting during camera system adjustments". (Refer to page 5-14)
3	6	2C	01	
4	6	90	00	
5	6	91	00	
6	6	92	YL	(Note 2)
7	6	93	YH	(Note 2)
8	6	01	79	Press PAUSE button.
9	6	07		Check the data changes to "01".
10	6	01	00	Press PAUSE button.
11	6	01	11	Press PAUSE button.
12	6	01	0B	Press PAUSE button. (Note 4)
13	6	02		Check the data changes to "01".

**Note 4:** The adjustment data will be automatically input to page: F, address: 3A to 3D and 59.

#### Processing after Completing Adjustment:

Order	Page	Address	Data	Procedure
1	6	01	00	Press PAUSE button.
2	6	2C	00	
3	6	92	00	
4	6	93	00	
5				Release the data setting performed at step 2 . (Refer to page 5-14)
6	0	01	00	

**10. Auto White Balance Adjustment**

Adjust to the proper auto white balance output data.  
If it is not correct, auto white balance and color reproducibility will be poor.

Mode	CAMERA
Subject	Clear chart (Color reproduction adjustment frame with the zoom lens at WIDE end)
Filter	Filter C14 for color temperature correction
Measurement Point	Displayed data of page: 1 (Note 3)
Measuring Instrument	Adjusting remote commander
Adjustment Page	F
Adjustment Address	3F, 40, 80, A9, AA
Specified Value	R ratio: 2720 to 2860 B ratio: 6060 to 61A0

**Note 1:** Check that the data of page: 6, address: 02 is "00".  
If not, turn the power of unit OFF/ON.

**Note 2:** Refer to "Picture Frame Setting" for YH and YL.

**Note 3:** The right 4 digits of the page: 1 displayed data of the adjusting remote commander.

1:XX:XX  
└──────────┘ Displayed data

**Note 4:** "Auto White Balance Adjustment" is available only once after the power is turned on. Turn the power off, then on again if the adjustment is retried.

**Adjusting method:**

Order	Page	Address	Data	Procedure
1				Place the C14 filter on the lens.
2	0	01	01	
3				Perform "Data setting during camera system adjustments". (Refer to page 5-14)
4	6	2C	01	
5	6	90	00	
6	6	91	00	
7	6	92	YL	(Note 2)
8	6	93	YH	(Note 2)
9	6	01	79	Press PAUSE button.
10	6	07		Check the data changes to "01".
11	6	01	00	Press PAUSE button.
12	6	01	A7	Press PAUSE button.
13	F	49 4A 4B 4C		Note down the data.
14	F	49 4A 4B 4C	27 C0 61 00	Press PAUSE button.
15	6	01	A5	Press PAUSE button. (Note 5)
16	6	02		Check the data changes to "01".
17	6	01	3F	Press PAUSE button.
18	0	03	04	

Order	Page	Address	Data	Procedure
19	1			Check that the displayed data (Note 3) satisfies the R ratio specified value.
20	0	03	05	
21	1			Check that the displayed data (Note 3) satisfies the B ratio specified value.

**Note 5:** The adjustment data will be automatically input to page: F, address: 3F, 40, 80, A9 and AA.

**Processing after Completing Adjustment:**

Order	Page	Address	Data	Procedure
1	0	03	00	
2	6	01	00	Press PAUSE button.
3	6	2C	00	
4	6	92	00	
5	6	93	00	
6	F	49 4A 4B 4C		Set the data noted down at step 13, and press PAUSE button.
7				Release the data setting performed at step 3 . (Refer to page 5-14)
8	0	01	00	
9				Remove the C14 filter on the lens.

**11. Color Reproduction Adjustment**

Adjust the color separation matrix coefficient so that proper color reproduction is produced.

Mode	CAMERA
Subject	Color bar chart (Color reproduction adjustment frame with the zoom lens at WIDE end)
Adjustment Page	F
Adjustment Address	41 to 48, 5C to 5F

**Note 1:** Check that the data of page: 6, address: 02 is "00".  
If not, turn the power of the unit OFF/ON.

**Note 2:** Refer to "Picture Frame Setting" for YH and YL.

**Note 3:** "Color Reproduction Adjustment" is available only once after the power is turned on. Turn the power off, then on again if the adjustment is retried.

**Adjusting method:**

Order	Page	Address	Data	Procedure
1	0	01	01	
2				Perform "Data setting during camera system adjustments". (Refer to page 5-14)
3	6	2C	01	
4	6	90	00	
5	6	91	00	
6	6	92	YL	(Note 2)
7	6	93	YH	(Note 2)
8	6	01	79	Press PAUSE button.
9	6	07		Check the data changes to "01".
10	6	01	00	Press PAUSE button.
11	6	01	AB	Press PAUSE button.
12	6	12	80	
13				Wait for 1 second.
14	6	12	00	
15				Wait for 2 seconds.
16	6	01	A9	Press PAUSE button. (Note 4)
17	6	02		Check the data changes to "01".

**Note 4:** The adjustment data will be automatically input to page: F, address: 41 to 48 and 5C to 5F.

**Processing after Completing Adjustment:**

Order	Page	Address	Data	Procedure
1	6	01	00	Press PAUSE button.
2	6	2C	00	
3	6	92	00	
4	6	93	00	
5				Release the data setting performed at step 2 . (Refer to page 5-14)
6	0	01	00	
7				Perform "Color Reproduction Check".

12. Color Reproduction Check

Mode	CAMERA
Subject	Color bar chart (Color reproduction adjustment frame with the zoom lens at WIDE end)
Measurement Point	Video terminal of A/V OUT jack (75 Ω terminated)
Measuring Instrument	Vectorscope
Specified Value	All color luminance points should settle within each color reproduction frame.

**Note 1:** Check that the data of page: 6, address: 02 is "00".  
If not, turn the power of the unit OFF/ON.

**Note 2:** Refer to "Picture Frame Setting" for YH and YL.

Adjusting method:

Order	Page	Address	Data	Procedure
1	0	01	01	
2				Perform "Data setting during camera system adjustments". (Refer to page 5-14)
3	6	2C	01	
4	6	90	00	
5	6	91	00	
6	6	92	YL	(Note 2)
7	6	93	YH	(Note 2)
8	6	01	79	Press PAUSE button.
9	6	07		Check the data changes to "01".
10	6	01	00	Press PAUSE button.
11	6	10	01	
12	E	52		Note down the data.
13	E	52	09	Press PAUSE button.
14	6	01	0F	Press PAUSE button.
15	6	12	80	
16				Wait for 1 second.
17	6	12	00	
18				Wait for 2 seconds.
19				Check the each color luminance point is in each color reproduction frame.

Processing after Completing Adjustment:

Order	Page	Address	Data	Procedure
1	6	01	00	Press PAUSE button.
2	6	10	00	
3	6	2C	00	
4	6	92	00	
5	6	93	00	
6	E	52		Set the data noted down at step 12, and press PAUSE button.
7				Release the data setting performed at step 2. (Refer to page 5-14)
8	0	01	00	

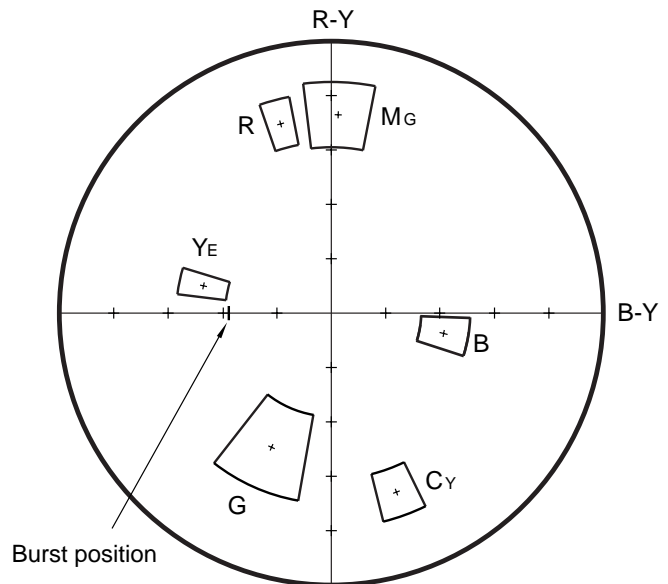

Fig. 5-1-17

**13. Auto White Balance Check**

Mode	CAMERA	
Subject	Clear chart (Color reproduction adjustment frame with the zoom lens at WIDE end)	
Measurement Point	Displayed data of Page: 1 (Note 3)	Video terminal A/V OUT jack (75 Ω terminated)
Measuring Instrument	Adjusting remote commander	Vectorscope
Specified Value	R ratio: 3E00 to 4200 B ratio: 3E00 to 4200	Fig. 5-1-18 (A) and (B)

**Note 1:** Check that the data of page: 6, address: 02 is "00".  
If not, turn the power of unit OFF/ON.

**Note 2:** Refer to "Picture Frame Setting" for YH and YL.

**Note 3:** The right 4 digits of the page: 1 displayed data of the adjusting remote commander.

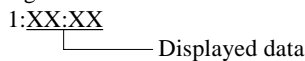

**Checking method:**

Order	Page	Address	Data	Procedure
1				Check that the lens is not covered with either filter.
2	0	01	01	
3				Perform "Data setting during camera system adjustments". (Refer to page 5-14)
4	6	2C	01	
5	6	90	00	
6	6	91	00	
7	6	92	YL (Note 2)	
8	6	93	YH (Note 2)	
9	6	01	79	Press PAUSE button.
10	6	07		Check the data changes to "01".
11	6	01	00	Press PAUSE button.
INDOOR data check (without ND filter)				
12	E	52		Note down the data.
13	E	52	0E	Press PAUSE button.
14	6	01	0F	Press PAUSE button.
15	0	03	04	
16	1			Check that the displayed data (Note 3) satisfied the R ratio specified value.
17	0	03	05	
18	1			Check that the displayed data (Note 3) satisfied the B ratio specified value.
INDOOR luminance point check				
19				Check that the center of the white luminance point within the circle shown Fig. 5-1-18 (A).

OUTDOOR luminance check				
20				Place the C14 filter on the lens.
21	E	4B		Note down the data.
22	E	4B	20	Press PAUSE button.
23	6	01	3F	Press PAUSE button.
24				Check that the center of the white luminance point settles in the circle shown Fig. 5-1-18 (B).

**Processing after Completing Adjustment:**

Order	Page	Address	Data	Procedure
1	0	03	00	
2	6	01	00	Press PAUSE button.
3	6	2C	00	
4	6	92	00	
5	6	93	00	
6	E	4B		Set the data noted down at step 21, and press PAUSE button.
7	E	52		Set the data noted down at step 12, and press PAUSE button.
8				Release the data setting performed at step 3 . (Refer to page 5-14)
9	0	01	00	
10				Remove the C14 filter on the lens.

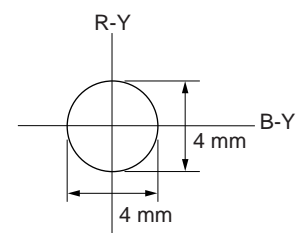

**Fig. 5-1-18 (A)**

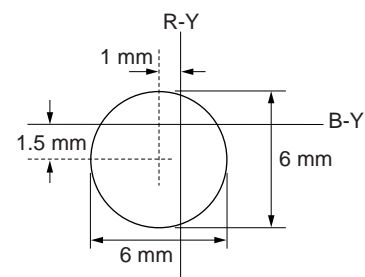

**Fig. 5-1-18 (B)**

**14. CCD White Defect Compensation**

Mode	CAMERA
Subject	Not required
Measurement Point	Displayed data of page: 6, address: 55
Measuring Instrument	Adjusting remote commander
Adjustment Page	7
Adjustment Address	88 to A3

**Note 1:** Check that the data of page: 6, address: 02 is "00".  
If not, turn the power of unit OFF/ON.

**Adjusting method:**

Order	Page	Address	Data	Procedure
1	0	01	01	
2				Perform "Data setting during camera system adjustments". (Refer to page 5-14)
3	F	DE		Note down the data.
4	F	DE	1E	Press PAUSE button.
5	F	E3		Note down the data.
6	F	E3	0E	Press PAUSE button.
7	6	01	8B	Press PAUSE button. (Note 2)
8	6	02		Check the data changes to "01".
9	6	55		Check the data. 00 to 7F: Normal 80 to FF: Defective
10	6	01	00	Press PAUSE button.
11	F	DE	0F	Press PAUSE button.
12	F	E3	60	Press PAUSE button.
13	6	01	87	Press PAUSE button.
14	6	02		Check the data changes to "01".
15	6	55		Check the data changes to "00".

**Note 2:** The adjustment data will be automatically input to  
page: 7, address: 88 to A3.

**Processing after Completing Adjustment:**

Order	Page	Address	Data	Procedure
1	6	01	00	Press PAUSE button.
2	F	E3		Set the data noted down at step 5, and press PAUSE button.
3	F	DE		Set the data noted down at step 3, and press PAUSE button.
4				Release the data setting performed at step 2 . (Refer to page 5-14)
5	0	01	00	

### 15. CCD Black Defect Compensation

Mode	CAMERA
Subject	Clear chart (Color reproduction adjustment frame)
Measurement Point	Displayed data of page: 6, address: 55
Measuring Instrument	Adjusting remote commander
Adjustment Page	7
Adjustment Address	60 to 87

**Note 1:** Check that the data of page: 6, address: 02 is "00".  
If not, turn the power of unit OFF/ON.

**Note 2:** Check that there are no dust, no dirt and reflection of the clear chart.

**Note 3:** Any subject other than the clear chart should be in the screen.

#### Adjusting method:

Order	Page	Address	Data	Procedure
1	0	01	01	
2				Perform "Data setting during camera system adjustments". (Refer to page 5-14)
3	F	DF		Note down the data.
4	F	DF	4C	Press PAUSE button.
5	6	2C	01	
6	6	90	00	
7	6	91	03	
8	6	92	00	
9	6	93	00	
10	6	01	79	Press PAUSE button.
11	6	30	01	
12	6	07		Check the data changes to "01".
13	6	01	8D	Press PAUSE button. (Note 4)
14	6	02		Check the data changes to "01".
15	6	55		Check the data. 00 to 0A: Normal 0B to FF: Defective
16	6	01	00	Press PAUSE button.
17	F	DF	5A	Press PAUSE button.
18	6	01	89	Press PAUSE button.
19	6	02		Check the data changes to "01".
20	6	55		Check the data changes to "00".

**Note 4:** The adjustment data will be automatically input to page: 7, address: 60 to 87.

#### Processing after Completing Adjustment:

Order	Page	Address	Data	Procedure
1	6	01	00	Press PAUSE button.
2	6	2C	00	
3	6	30	00	
4	6	91	00	
5	F	DF		Set the data noted down at step 3, and press PAUSE button.
6				Release the data setting performed at step 2 . (Refer to page 5-14)
7	0	01	00	

## 16. Strobe White Balance Adjustment

Adjust the white balance when the strobe light flashed.

Mode	CAMERA
Subject	Flash adjustment box (Note 3) (1.0 m from the front of the lens)
Adjustment Page	F
Adjustment Address	4D, 4E, 64, 69 to 6B
Specified Value	Y level data: 60 to 94 (Note 4) R-Y level data: FA to FF or 00 to 06 (Note 5) B-Y level data: FA to FF or 00 to 06 (Note 5)

**Note 1:** Check that the data of page: 6, address: 02 is "00".

If not, turn the power of unit OFF/ON.

**Note 2:** Perform this adjustment in the Flash adjustment box.

**Note 3:** Refer to "4. Preparing the Flash adjustment box". (See page 5-7)

**Note 4:** Displayed data of page: F, address: 64, of the adjusting remote commander.

F:XX:64

Y level data

**Note 5:** The right four digits of the page: 1 displayed data of the adjusting remote commander.

1:XX:XX

B-Y level data

R-Y level data

**Note 6:** "Strobe White Balance Adjustment" is available only once after the power is turned on. Turn the power off, then on again if the adjustment is retried.

### Switch setting:

1) FLASH ..... ON

### Adjusting method:

Order	Page	Address	Data	Procedure
1	0	01	01	
2				Perform "Data setting during camera system adjustments". (Refer to page 5-14)
3	6	90	00	
4	6	91	00	
5	6	92	FF	
6	6	93	FF	
7	6	2C	01	
8	6	01	79	Press PAUSE button.
9	6	07		Check the data changes to "01".
10	6	01	67	Press PAUSE button.
11				Check the flashing of strobe light.
12	6	02		Check the data changes to "01".
13	6	01	00	Press PAUSE button.
14	6	01	67	Press PAUSE button.
15				Check the flashing of strobe light.
16	6	02		Check the data changes to "01".
17	6	01	00	Press PAUSE button.
18	6	01	B9	Press PAUSE button. (Note 7)
19				Check the flashing of strobe light.
20	6	02		Check the data changes to "01".
21	6	01	00	Press PAUSE button.
22	6	01	67	Press PAUSE button.
23				Check the flashing of strobe light.
24	6	02		Check the data changes to "01".
25	F	64		Check that the data satisfies the Y level data satisfied value. (Note 4)
26	0	03	02	
27	1			Check the R-Y and B-Y level data (Note 5) satisfies the specified value.

**Note 7:** The adjustment data will be automatically input to page: F, address: 4D, 4E, 64 and 69 to 6B.

### Processing after Completing Adjustment:

Order	Page	Address	Data	Procedure
1	0	03	00	
2	6	01	00	Press PAUSE button.
3	6	2C	00	
4	6	92	00	
5	6	93	00	
6				Release the data setting performed at step 2. (Refer to page 5-14)
7	0	01	00	

### 1-5. LCD SYSTEM ADJUSTMENTS

Before perform the LCD system adjustments, check that the specified values of “VIDEO SYSTEM ADJUSTMENTS” are satisfied.

**Note 1:** The back light (fluorescent tube) is driven with high voltage AC power. Therefore, do not touch the back light directly, otherwise you will feel an electric shock.

**Note 2:** Taken an extreme care not to destroy the liquid crystal display module by static electricity when replacing it.

**Note 3:** Set the LCD BRIGHT (Menu display) to the center.

### [Adjusting connector]

Most of the measuring points for adjusting the LCD system are concentrated in CN401 of the SY-68 board.

Connect the Measuring Instruments via the CPC-9 jig (J-6082-393-C).

The following table shows the Pin No. and signal name of CN401.

Pin No.	Signal Name	Pin No.	Signal Name
1	BL-L1	10	HL_UNREG
2	N.C.	11	LANC_IN
3	N.C	12	LANC_OUT
4	REG_GND	13	N.C.
5	N. C.	14	N.C.
6	BL_L2	15	N.C.
7	HSY	16	N.C.
8	PANEL_COM	17	N.C.
9	VG	18	N.C

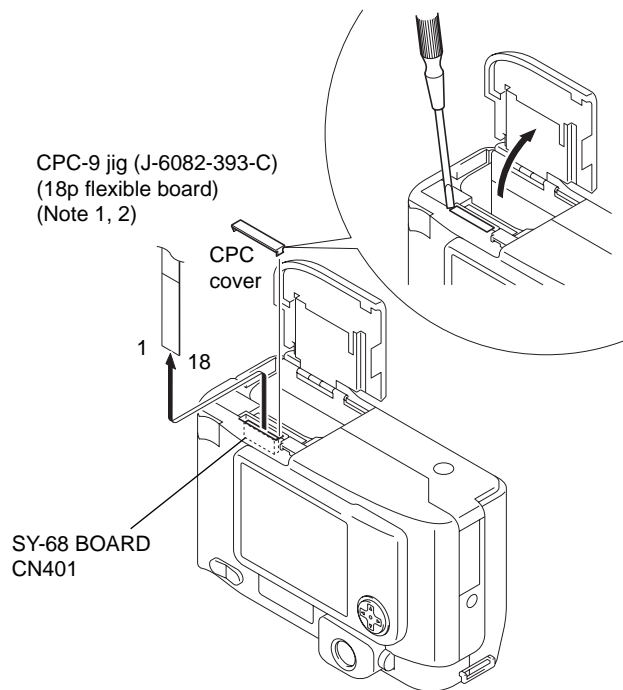

**Note 1:** Don t use the 12 pin flexible board of CPC-9 jig. It causes damage to the unit.

**Note 2:** The old CPC-9 jig (Parts code: J-6082-393-B) cannot be used, because it cannot operate the adjusting remote commander.

**Fig. 5-1-19**

**1. LCD Initial Data Input (1)**

Mode	PLAY
Signal	Arbitrary
Adjustment Page	B
Adjustment Address	3A to 3F

**Adjusting method:**

- 1) Select page: 0, address: 01, and set data: 01.
- 2) Select page: B, and enter the data given in the following table.

**Note:** Press the PAUSE button each time the data are set, as the data are written to non-volatile memory (EEPROM).

Address	Data	Remark
3A	59	Fixed data
3B	00	
3C	04	
3D	5B	
3E	00	
3F	02	

**Processing after Completing Adjustments:**

- 1) Select page: 0, address: 01, and set data: 00.

**2. LCD Initial Data Input (2)**

Mode	PLAY
Signal	Arbitrary
Adjustment Page	D
Adjustment Address	CE to D9, DC to DF

**Adjusting method:**

- 1) Select page: 0, address: 01, and set data: 01.
- 2) Select page: D, and enter the data given in the following table.

**Note:** Press the PAUSE button each time the data are set, as the data are written to non-volatile memory (EEPROM).

Address	Data	Remark
CE	A2	Fixed value
CF	B7	
D0	AD	Bright adjustment
D1	7E	Color adjustment
D2	99	White blance adjustment
D3	75	
D4	B7	Contrast adjustment
D5	3C	D range adjustment
D6	6E	V-COM level adjustment
D7	93	VCO adjustment (NTSC)
D8	61	V-COM adjustment
D9	97	Fixed value
DC	46	
DD	6F	VCO adjustment (PAL)
DE	C6	Fixed value
DF	B7	

**Processing after Completing Adjustments:**

- 1) Select page: 0, address: 01, and set data: 00.

### 3. VCO Adjustment (SY-68 Board)

Set the VCO free-run frequency. If deviated, the LCD screen will be blurred.

Mode	PLAY
Signal	Arbitrary
Measurement Point	Pin ⑦ of CN401 (HSY)
Measuring Instrument	Frequency counter
Adjustment Page	D
Specified Value	D7 (NTSC) DD (PAL)
Specified Value	f = 15734 ± 30 Hz (NTSC) f = 16175 ± 30 Hz (PAL)

#### Menu setting:

- 1) VIDEO OUT of SET UP menu..... NTSC (NTSC mode)  
(This adjustment must be performed in NTSC mode, so don't set the menu setting to "PAL")

#### Adjusting method:

Order	Page	Address	Data	Procedure
1	0	01	01	
2	5	F0	01	
3	D	D7		Change the data and set the frequency (f) to the NTSC specified value.
4	D	D7		Press PAUSE button.
4	D	DD		Change the data and set the frequency (f) to the PAL specified value.
5	D	DD		Press PAUSE button.

#### Processing after Completing Adjustment:

Order	Page	Address	Data	Procedure
1	5	F0	00	
2	0	01	00	

### 4. D Range Adjustment (SY-68 Board)

Set the D range of the LCD driver to the specified value. If deviated, the LCD screen will become blackish or saturated (whitish)

Mode	PLAY
Signal	Arbitrary
Measurement Point	Pin ⑨ of CN401 (VG) External trigger: Pin ⑧ of CN401 (PANEL_COM)
Measuring Instrument	Oscilloscope
Adjustment Page	D
Adjustment Address	D5
Specified Value	A = 2.52 ± 0.05 Vp-p

#### Adjusting method:

Order	Page	Address	Data	Procedure
1	0	01	01	
2	4	F1	03	
3	D	D5		Change the data and set the voltage (A) to the specified value.
4	D	D5		Press PAUSE button.

#### Processing after Completing Adjustment:

Order	Page	Address	Data	Procedure
1	4	F1	00	
2	0	01	00	

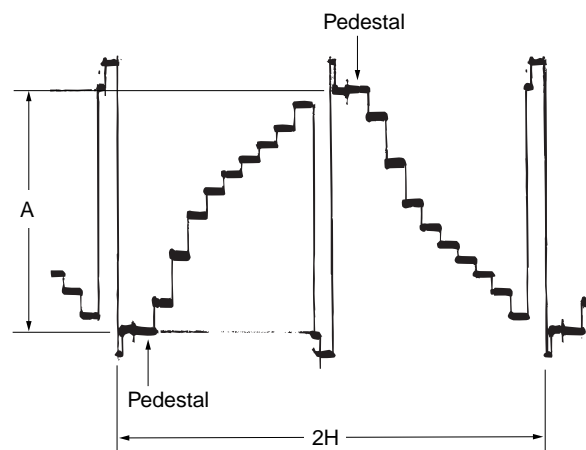

A: Pedestal level difference between 1H period and previous 1H period.

Fig. 5-1-20

## 5. Bright Adjustment (SY-68 Board)

Set the level of the VIDEO signal for driving the LCD to the specified value.

If deviated, the LCD screen image will be blackish or saturated (whitish).

Mode	PLAY
Signal	Arbitrary
Measurement Point	Pin ⑨ of CN401 (VG) External trigger: Pin ⑩ of CN401 (PANEL_COM)
Measuring Instrument	Oscilloscope
Adjustment Page	D
Adjustment Address	D0
Specified Value	$A = 1.32 \pm 0.05 V_{p-p}$

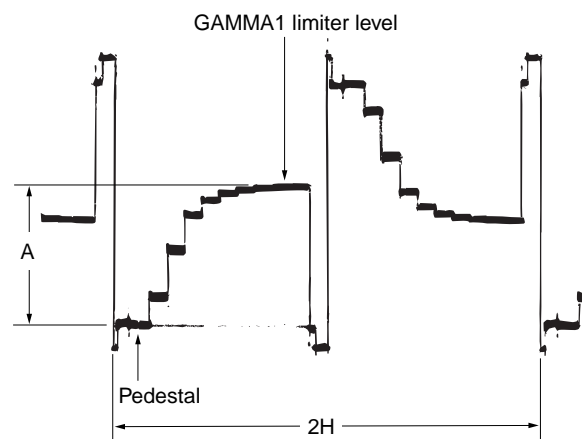

A: Between the pedestal and GAMMA1 limiter level

**Fig. 5-1-21**

### Adjusting method:

Order	Page	Address	Data	Procedure
1	0	01	01	
2	4	10	01	
3	4	F1	03	
4	D	D0		Change the data and set the voltage (A) to the specified value.
5	D	D0		Press PAUSE button.
6	D	D0		Read the data and this data is named Dref.
7				Convert Dref to decimal notation, and obtain Dref'. (Note)
8				Calculate $D_{CE}'$ and $D_{DE}'$ using following equations. (decimal calculation) $D_{CE}' = D_{ref}' - 11$ $D_{DE}' = D_{ref}' + 24$
9				Convert $D_{CE}'$ and $D_{DE}'$ to hexadecimal numbers, and obtain $D_{CE}$ and $D_{DE}$ . (Note)
10	D	CE	$D_{CE}$	Press PAUSE button.
11	D	DE	$D_{DE}$	Press PAUSE button.

**Note:** Refer to table 5-2-2. "Hexadecimal-decimal conversion table".

### Processing after Completing Adjustment:

Order	Page	Address	Data	Procedure
1	4	F1	00	
2	4	10	00	
3	0	01	00	

### 6. Contrast Adjustment (SY-68 Board)

Set the level of the VIDEO signal for driving the LCD to the specified value.

If deviated, the LCD screen image will be blackish or saturated (whitish).

Mode	PLAY
Signal	Arbitrary
Measurement Point	Pin ⑨ of CN401 (VG) External trigger: Pin ⑧ of CN401 (PANEL_COM)
Measuring Instrument	Oscilloscope
Adjustment Page	D
Adjustment Address	D4
Specified Value	$A = 2.35 \pm 0.07 \text{ Vp-p}$

#### Adjusting method:

Order	Page	Address	Data	Procedure
1	0	01	01	
2	4	F1	03	
3	D	D4		Change the data and set the voltage (A) to the specified value.
4	D	D4		Press PAUSE button.
5	D	D4		Read the data and this data is named Dref.
6	D	CF	Dref	Press PAUSE button.
7	D	DF	Dref	Press PAUSE button.

#### Processing after Completing Adjustment:

Order	Page	Address	Data	Procedure
1	4	F1	00	
2	0	01	00	

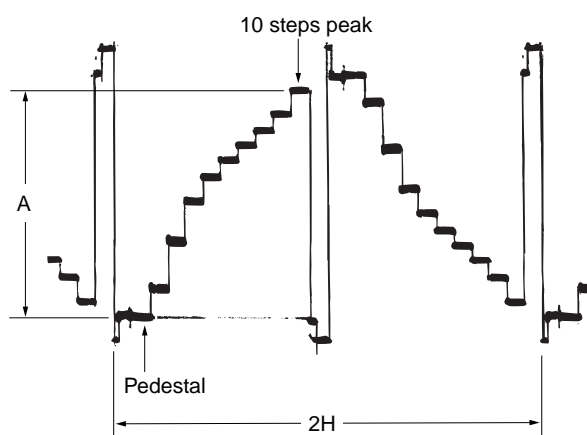

A: Between the pedestal and 10 steps peak

Fig. 5-1-22

### 7. Color Adjustment (SY-68 Board)

Set the color saturation to the standard value.

If, deviated, the color will be dark or light.

Mode	PLAY
Signal	Arbitrary
Measurement Point	Pin ⑨ of CN401 (VG) External trigger: Pin ⑧ of CN401 (PANEL_COM)
Measuring Instrument	Oscilloscope
Adjustment Page	D
Adjustment Address	D1
Specified Value	$A = 348 \pm 50 \text{ mVp-p}$

#### Adjusting method:

Order	Page	Address	Data	Procedure
1	0	01	01	
2	4	F1	04	
3	D	D1		Change the data and set the voltage (A) to the specified value.
4	D	D1		Press PAUSE button.

#### Processing after Completing Adjustment:

Order	Page	Address	Data	Procedure
1	4	F1	00	
2	0	01	00	

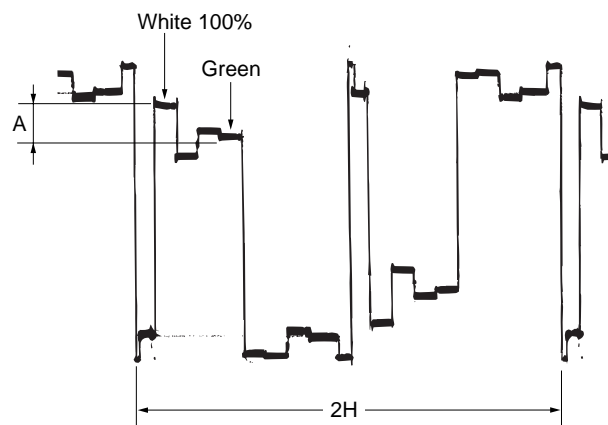

A: Between the white 100% (Reference level) and green

Fig. 5-1-23

**8. V-COM Level Adjustment (SY-68 Board)**

Set the common electrode drive signal level of LCD to the specified value.

Mode	PLAY
Signal	Arbitrary
Measurement Point	Pin ③ of CN401 (PANEL_COM)
Measuring Instrument	Oscilloscope
Adjustment Page	D
Adjustment Address	D6
Specified Value	$A = 5.42 \pm 0.05 \text{ Vp-p}$

**Adjusting method:**

Order	Page	Address	Data	Procedure
1	0	01	01	
2	D	D6		Change the data and set the VCOM signal level (A) to the specified value.
3	D	D6		Press PAUSE button.

**Processing after Completing Adjustment:**

Order	Page	Address	Data	Procedure
1	0	01	00	

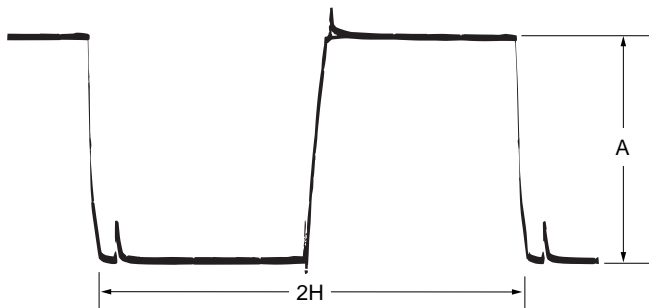

Fig. 5-1-24

**9. V-COM Adjustment (SY-68 Board)**

Set the DC bias of the common electrode drive signal of LCD to the specified value.

If deviated, the LCD display will be move, producing flicker and conspicuous vertical lines.

Mode	PLAY
Signal	Arbitrary
Measurement Point	Check on the LCD screen
Measuring Instrument	
Adjustment Page	D
Adjustment Address	D8
Specified Value	The brightness difference between the section-A and section-B is minimum

**Note:** Perform “Bright Adjustment” and “Contrast Adjustment” before this adjustment.

**Adjusting method:**

Order	Page	Address	Data	Procedure
1	0	01	01	
2	4	F1	01	
3	4	10	02	
4	D	D8		Change the data so that the brightness of the section A and section B is equal.
5	D	D8		Press PAUSE button.

**Processing after Completing Adjustment:**

Order	Page	Address	Data	Procedure
1	4	F1	00	
2	4	10	00	
3	0	01	00	

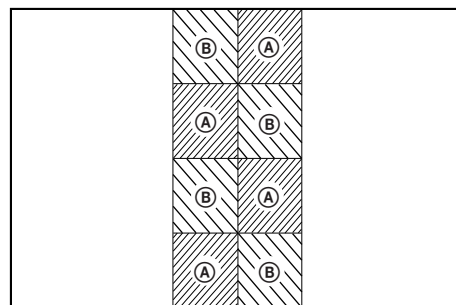

Fig. 5-1-25

### 10. White Balance Adjustment (SY-68 Board)

Correct the white balance.

If deviated, the LCD screen color cannot be reproduced.

Mode	PLAY
Signal	Arbitrary
Measurement Point	Check on the LCD screen
Measuring Instrument	
Adjustment Page	D
Adjustment Address	D2, D3
Specified Value	LCD screen must not be colored

**Note:** Check the white balance only when replacing the following parts.

If necessary, adjust them.

1. LCD panel
2. Light induction plate
3. IC802

#### Adjusting method:

Order	Page	Address	Data	Procedure
1	0	01	01	
2	4	F1	02	
3	D	D2 D3	99 75	Press PAUSE button. (Initial value) (Note 2)
4				Check that the LCD screen is not colored. If not colored, proceed to "Processing after Completing Adjustments".
5	D	D2 D3		Change the data and so that the LCD screen is not colored. (Note 2)

**Note 2:** To write in the non-volatile memory (EEPROM), press the PAUSE button each time to set the data.

#### Processing after Completing Adjustment:

Order	Page	Address	Data	Procedure
1	4	F1	00	
2	0	01	00	

## 5-2. SERVICE MODE

### 2-1. ADJUSTING REMOTE COMMANDER

The adjusting remote commander is used for changing the calculation coefficient in signal processing, EVR data, etc. The adjusting remote commander performs bi-directional communication with the unit using the remote commander signal line (LANC). The resultant data of this bi-directional communication is written in the non-volatile memory.

#### 1. Used the Adjusting Remote Commander

- 1) Connect the adjusting remote commander to the CN401 on the SY-68 board via CPC-9 jig (J-6082-393-C).
  - 2) Adjust the HOLD switch of the adjusting remote commander to "HOLD" (SERVICE position).
  - 3) Turn on the power with the POWER switch of the unit.
- If it has been properly connected, the LCD on the adjusting remote commander will display as shown in Fig. 5-2-1.

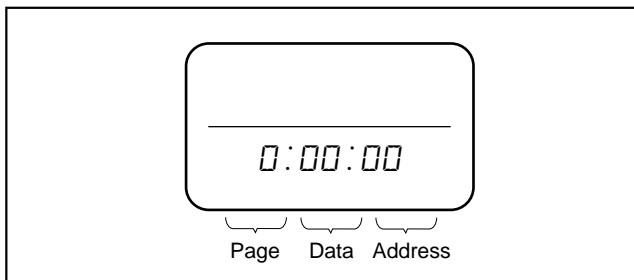

**Fig. 5-2-1**

- 4) Operate the adjusting remote commander as follows.
  - Changing the page
 

The page increases when the EDIT SEARCH + button is pressed, and decreases when the EDIT SEARCH – button is pressed. There are altogether 16 pages, from 0 to F.

Hexadecimal notation	0 1 2 3 4 5 6 7 8 9 A B C D E F
LCD Display	0 1 2 3 4 5 6 7 8 9 A b c d E F
Decimal notation conversion value	0 1 2 3 4 5 6 7 8 9 10 11 12 13 14 15

**Table 5-2-1**

- Changing the address
 

The address increases when the FF (▶▶) button is pressed, and decreases when the REW (▶▶) button is pressed. There are altogether 256 addresses, from 00 to FF.
- Changing the data (Data setting)
 

The data increases when the PLAY (▶) button is pressed, and decreases when the STOP (■) button is pressed. There are altogether 256 data, from 00 to FF.
- Writing the adjustment data
 

The PAUSE button must be pressed to write the adjustment data in the nonvolatile memory. (The new adjustment data will not be recorded in the nonvolatile memory if this step is not performed)

#### 2. Precautions upon Using the Adjusting Remote Commander

Mishandling of the adjusting remote commander may erase the correct adjustment data at times. To prevent this, it is recommended that all adjustment data be noted down before beginning adjustments and new adjustment data after each adjustment.

## 2-2. DATA PROCESS

The calculation of the adjusting remote commander display data (hexadecimal notation) are required for obtaining the adjustment data of some adjustment items. In this case, after converting the hexadecimal notation to decimal notation, calculate and convert the result to hexadecimal notation, and use it as the adjustment data. Table 5-2-2. indicates the hexadecimal notation- the decimal notation, calculation table.

Hexadecimal notation-Decimal notation																
The lower digits of the hexadecimal notation The upper digits of the hexadecimal notation	0	1	2	3	4	5	6	7	8	9	A	B	C	D	E	F
											(A)	(B)	(C)	(D)	(E)	(F)
0	0	1	2	3	4	5	6	7	8	9	10	11	12	13	14	15
1	16	17	18	19	20	21	22	23	24	25	26	27	28	29	30	31
2	32	33	34	35	36	37	38	39	40	41	42	43	44	45	46	47
3	48	49	50	51	52	53	54	55	56	57	58	59	60	61	62	63
4	64	65	66	67	68	69	70	71	72	73	74	75	76	77	78	79
5	80	81	82	83	84	85	86	87	88	89	90	91	92	93	94	95
6	96	97	98	99	100	101	102	103	104	105	106	107	108	109	110	111
7	112	113	114	115	116	117	118	119	120	121	122	123	124	125	126	127
8	128	129	130	131	132	133	134	135	136	137	138	139	140	141	142	143
9	144	145	146	147	148	149	150	151	152	153	154	155	156	157	158	159
A (A)	160	161	162	163	164	165	166	167	168	169	170	171	172	173	174	175
①→ B (B)	176	177	178	179	180	181	182	183	184	185	186	187	188	189	190	191
C (C)	192	193	194	195	196	197	198	199	200	201	202	203	204	205	206	207
D (D)	208	209	210	211	212	213	214	215	216	217	218	219	220	221	222	223
E (E)	224	225	226	227	228	229	230	231	232	233	234	235	236	237	238	239
F (F)	240	241	242	243	244	245	246	247	248	249	250	251	252	253	254	255

②  
↓

①→

**Note :** ( ) indicate the adjusting remote control unit display.

**(Example)** In the case that the adjusting remote control unit display are BD (BD).  
As the upper digit of the hexadecimal notation is B (B), and the lower digit is D (D), the intersection “189” of the ① and ② in the above table is the decimal notation to be calculated.

Table 5-2-2

## 2-3. SERVICE MODE

### 1. Setting the Test Mode

Page D	Address 10
--------	------------

Data	Function
00	Normal
01	Forced CAMERA mode power ON
02	Forced PLAY mode power ON
03	Forced MOVIE mode power ON

- Before setting the data, select page: 0, address: 01, and set data: 01.
- For page D, the data set is recorded in the non-volatile memory by pressing the PAUSE button of the adjusting remote commander. In this case, take note that the test mode will not be exited even when the main power is turned off.
- After completing adjustments/repairs, be sure to return the data of this address to "00", and press the PAUSE button of the adjusting remote commander.  
Select page: 0, address: 01, and set data: 00.

### 2. Bit Value Discrimination

Bit values must be discriminated using the display data of the adjusting remote commander for following items. Use the table below to discriminate if the bit value is "1" or "0".

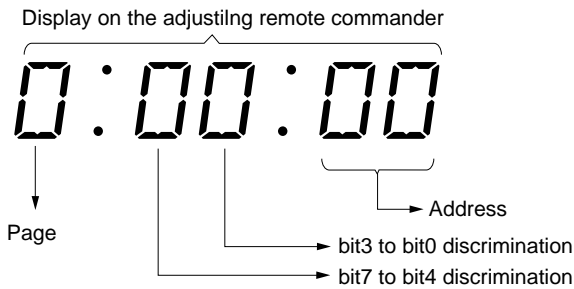

Display on the Adjusting remote commander	Bit values			
	bit3 or bit7	bit2 or bit6	bit1 or bit5	bit0 or bit4
0	0	0	0	0
1	0	0	0	1
2	0	0	1	0
3	0	0	1	1
4	0	1	0	0
5	0	1	0	1
6	0	1	1	0
7	0	1	1	1
Ⓐ 8	1	0	0	0
9	1	0	0	1
A (H)	1	0	1	0
B (b)	1	0	1	1
C (c)	1	1	0	0
D (d)	1	1	0	1
Ⓑ E (É)	1	1	1	0
F (F)	1	1	1	1

**Example:** If "8E" is displayed on the adjusting remote commander, the bit values for bit7 to bit4 are shown in the Ⓐ column, and the bit values for bit3 to bit0 are shown in the Ⓑ column.

### 3. Mode Dial Check (1)

Page 2	Address 94
--------	------------

Data	Function
00 to 14	S
15 to 3D	A
3E to 67	M
68 to A0	SCN
A1 to D0	MOVIE
D1 to FF	CAMERA

**Using method:**

- 1) Select page: 2, address: 94.
- 2) By discriminating the bit value of display data, the state of the switches can be discriminated.

### 4. Mode Dial Check (2)

Page 2	Address 80, 86
--------	----------------

Address	Bit	Function	When bit value=1	When bit value=0
80	1	PLAY	others	PLAY
86	6	SET UP	others	SET UP

**Using method:**

- 1) Select page: 2, address: 80 and 86.
- 2) By discriminating the bit value of display data, the state of the switches can be discriminated.

### 5. Jog Dial Check

Page 2	Address 84
--------	------------

**Using method:**

- 1) Select page: 2, address: 84.
- 2) Turn down the dial and check that number of units of the data is changed as  
0 → 8 → C → 4 → .....
- 3) Turn up the dial and check that number of unit of the data is changed as  
0 → 4 → C → 8 → .....

### 6. Switch Check (1)

Page 2	Address 80
--------	------------

Bit	Function	When bit value=1	When bit value=0
0	POWER SW	OFF	ON
1	PLAY (Mode Dial)	others	PLAY
2			
3	SHUTTR SW (CONTROL SWITCH BLOCK (SHUTTER))	OFF	ON
4	XSHUTTERLOCK SW (CONTROL SWITCH BLOCK (SHUTTER))	OFF	ON

**Using method:**

- 1) Select page: 2, address: 80.
- 2) By discriminating the bit value of display data, the state of the switches can be discriminated.

## 7. Switch Check (2)

Page 2	Address 90 to 93
--------	------------------

### Using method:

- 1) Select page: 2, addresses: 90 to 93.
- 2) By discriminating the display data, the pressed key can be discriminated.

Address	Data						
	00 to 0C	0D to 27	28 to 48	49 to 74	75 to A6	A7 to DD	DE to FF
90 (KEY AD0) (IC402 ㉔)	CONTROL DOWN (KY-55 board) (S933)	CONTROL UP (KY-55 board) (S933)	MENU (KY-55 board) (S936)				
91 (KEY AD1) (IC402 ㉕)	CONTROL RIGHT (KY-55 board) (S933)	CONTROL LEFT (KY-55 board) (S933)	CONTROL SET (KY-55 board) (S933)				
92 (KEY AD2) (IC402 ㉖)	DSPL/LCD ON/OFF (KY-55 board) (S932)	AE LOCK (KY-55 board) (S931)	EXPOSURE (KY-55 board) (S934)	FOCUS (KY-55 board) (S935)	SPOT METER (KY-55 board) (S937)		
93 (KEY AD3) (IC402 ㉗)	ZOOM (W) (CONTROL SWITCH BLOCK (ZOOM))	ZOOM (T) (CONTROL SWITCH BLOCK (ZOOM))	JOG DIAL (CONTROL SWITCH BLOCK (ZOOM))				

## 8. LED, LCD Check

Page 2	Address 04	Data 01
--------	------------	---------

### Using method:

- 1) Select page: 2, address: 04, and set data: 01.
- 2) Check that all LED except for the ACCESS LED are lit and all segments of LCD (display window) are lit.
- 3) Select page: 2, address: 04, and set data: 00.

## 9. Self Diagnosis Code

Display Code	Countermeasure	Cause	Caution Display During Error
C:32:□□	Turn the power off and on again.	Trouble with hardware.	SYSTEM ERROR
C:13:□□	Format the "Memory stick".	Unformatted memory stick is inserted.	FORMAT ERROR
	Insert a new "Memory Stick".	Memory stick is broken.	MEMORY STICK ERROR
E:61:□□	Checking of lens drive circuit.	When failed in the focus and zoom initialization.	—
E:91:□□	Checking of flash unit or replacement of flash unit.	Abnormality when flash is being charged.	

## SECTION 6 REPAIR PARTS LIST

### 6-1. EXPLODED VIEWS

**NOTE:**

- -XX and -X mean standardized parts, so they may have some difference from the original one.
- Items marked "\*" are not stocked since they are seldom required for routine service. Some delay should be anticipated when ordering these items.
- The mechanical parts with no reference number in the exploded views are not supplied.
- Accessories are given in the last of the electrical parts list.

The components identified by mark  $\Delta$  or dotted line with mark  $\Delta$  are critical for safety. Replace only with part number specified.

Les composants identifiés par une marque  $\Delta$  sont critiques pour la sécurité. Ne les remplacer que par une pièce portant le numéro spécifié.

### 6-1-1. MAIN SECTION

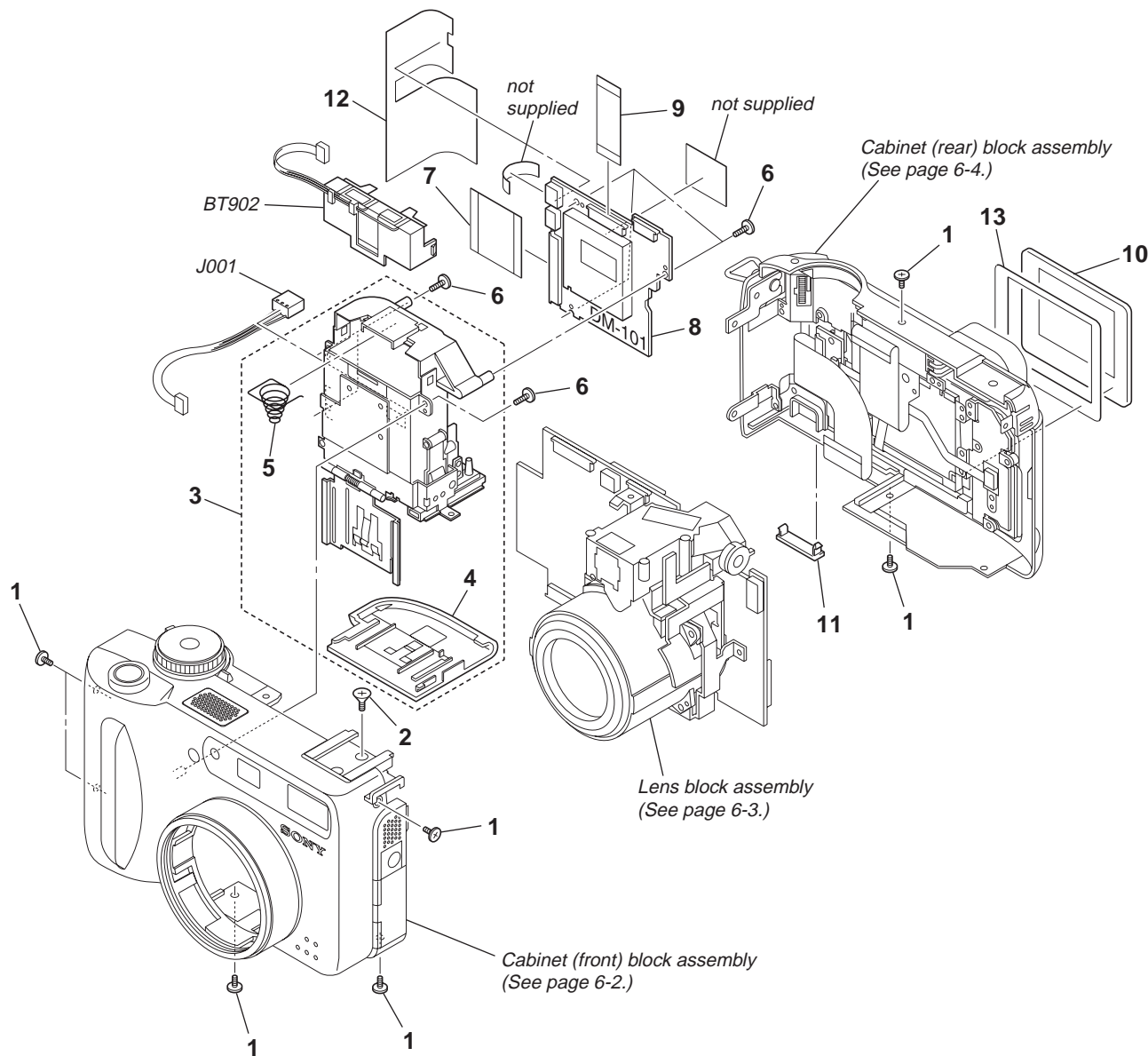

Ref. No.	Part No.	Description	Remark	Ref. No.	Part No.	Description	Remark
1	3-069-158-01	PROCESS, (M2) INTERIOR LOCK		9	1-681-658-11	FP-037 FLEXIBLE BOARD	
2	3-069-159-01	PROCESS, (M2) INTERIOR LOCK		10	3-068-646-01	LCD WINDOW	
3	X-3951-668-1	HOLDER ASSY, BATTERY		11	3-068-652-01	CPC LID	
4	3-068-640-01	LID, BATTERY		12	3-068-691-01	TAPE MS	
5	3-969-380-01	SPRING, BATTERY		13	3-068-658-01	SHEET, WINDOW ADHESIVE	
6	3-713-791-11	SCREW (M1.7X5), TAPPING, P2		BT902	1-694-816-11	TERMINAL BOARD, BATTERY	
7	1-681-657-11	FP-036 FLEXIBLE BOARD		J001	1-794-045-61	CONNECTOR, DC-IN	
8	A-7074-849-A	DM-101 BOARD, COMPLETE					

## 6-1-2. CABINET (FRONT) BLOCK ASSEMBLY

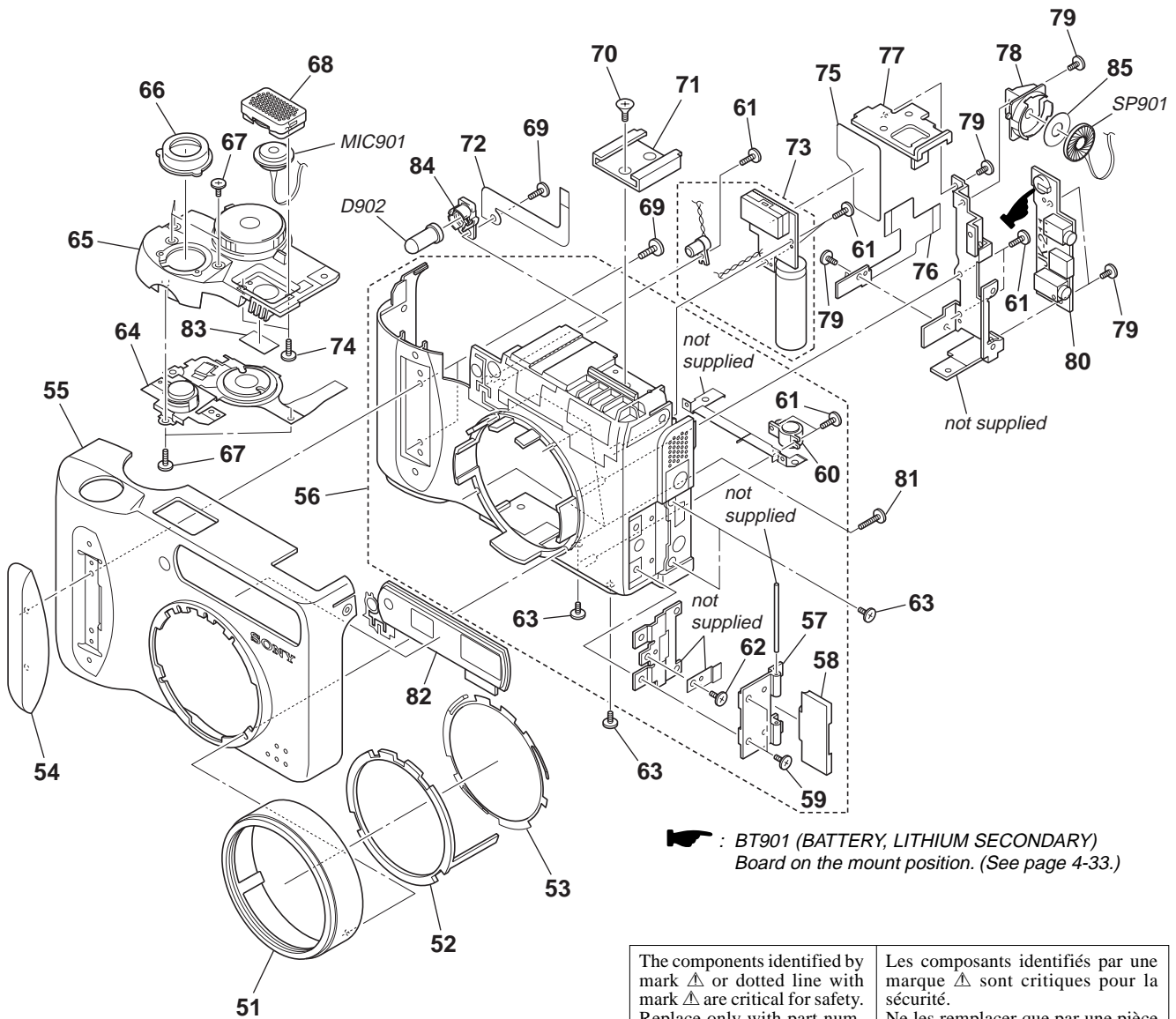

 : BT901 (BATTERY, LITHIUM SECONDARY)  
Board on the mount position. (See page 4-33.)

The components identified by mark  $\triangle$  or dotted line with mark  $\triangle$  are critical for safety. Replace only with part number specified.

Les composants identifiés par une marque  $\triangle$  sont critiques pour la sécurité. Ne les remplacer que par une pièce portant le numéro spécifié.

Ref. No.	Part No.	Description	Remark	Ref. No.	Part No.	Description	Remark
51	3-068-605-01	SCREW, FILTER		70	3-069-159-01	PROCESS, (M2) INTERIOR LOCK	
52	3-068-609-01	RING, SENSOR		71	3-067-469-11	SHOE, ACCESSORY	
53	3-068-610-01	SPRING, SENSOR		72	1-681-662-11	FP-041 FLEXIBLE BOARD	
54	3-068-608-01	GRIP		$\triangle$ 73	1-476-673-11	FLASH UNIT	
55	3-068-603-01	COVER, CABINET (FRONT)		74	3-713-791-71	SCREW (M1.7X4)	
56	X-3951-665-1	CABINET (FRONT) ASSY		75	3-068-614-01	ST INSULATING SHEET	
57	3-068-688-01	RETAINER, COVER SHAFT		76	1-681-661-21	FP-040 FLEXIBLE BOARD	
58	3-068-611-01	COVER, JACK		77	3-068-659-01	PLATE, SHOE FIXED	
59	3-968-729-51	SCREW (M2), LOCK ACE, P2		78	3-068-660-01	HOLDER (A), SP	
60	3-060-274-01	SCREW, TRIPOD		79	3-056-030-31	ACE (M1.7), 0 PLATE 2 MAIN LOCK	
61	3-713-791-11	SCREW (M1.7X5), TAPPING, P2		80	A-7074-850-A	JK-211 BOARD, COMPLETE	
62	3-056-233-11	SCREW (M2), LOCK ACE, P2		81	3-069-160-01	PROCESS, (M1.7) INTERIOR LOCK	
63	3-069-158-11	PROCESS, (M2) INTERIOR LOCK		82	X-3951-666-1	WINDOW ASSY	
64	1-476-666-11	SWITCH BLOCK, CONTROL (MODE)		83	3-062-299-01	SHEET, MICROPHONE	
65	X-3951-667-1	CABINET ASSY, UPPER		84	3-068-693-01	LED HOLDER	
66	3-068-631-01	ESCUTCHEON, RELEASE		85	3-069-404-01	SPACER, SP	
67	3-061-216-01	ACE (M1.7), SPECIAL HEAD LOCK		D902	8-719-084-32	DIODE (LED) TLOH20TP	
68	X-3951-670-1	GRILLE ASSY, MICROPHONE		MIC901	1-542-428-21	MICROPHONE	
69	3-948-339-61	TAPPING		SP901	1-529-857-21	SPEAKER (1.6cm)	

### 6-1-3. LENS BLOCK ASSEMBLY

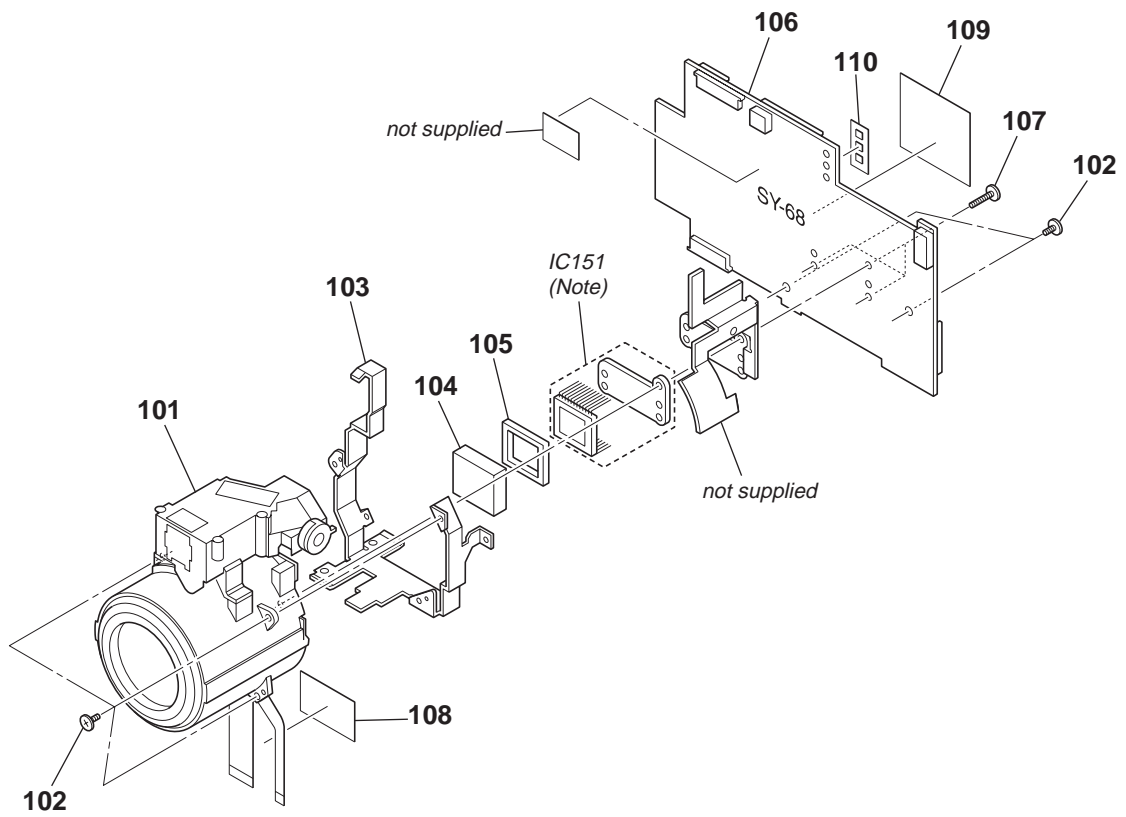

(Note) Be sure to read "Precautions for Replacement of CCD Imager" on page 4-11 when changing the CCD imager.

Ref. No.	Part No.	Description	Remark	Ref. No.	Part No.	Description	Remark
101	A-7031-248-A	LENS ASSY		107	3-318-203-11	SCREW (B1.7X6), TAPPING	
102	3-056-030-31	ACE (M1.7), O PLATE 2 MAIN LOCK		108	3-069-236-01	TAPE (LE)	
103	3-068-643-01	FRAME, LENS		109	3-068-601-01	DDC RADIATION SHEET	
104	1-758-437-11	FILTER BLOCK, OPTICAL		110	3-069-176-01	SHEET, LIGHT INTERCEPTION	
105	3-067-751-01	RUBBER (N), SEAL		IC151	A-7031-268-A	CCD BLOCK ASSY (CCD IMAGER)(Note)	
106	A-7074-888-A	SY-68 BOARD, COMPLETE (SERVICE)					

## 6-1-4. CABINET (REAR) BLOCK ASSEMBLY

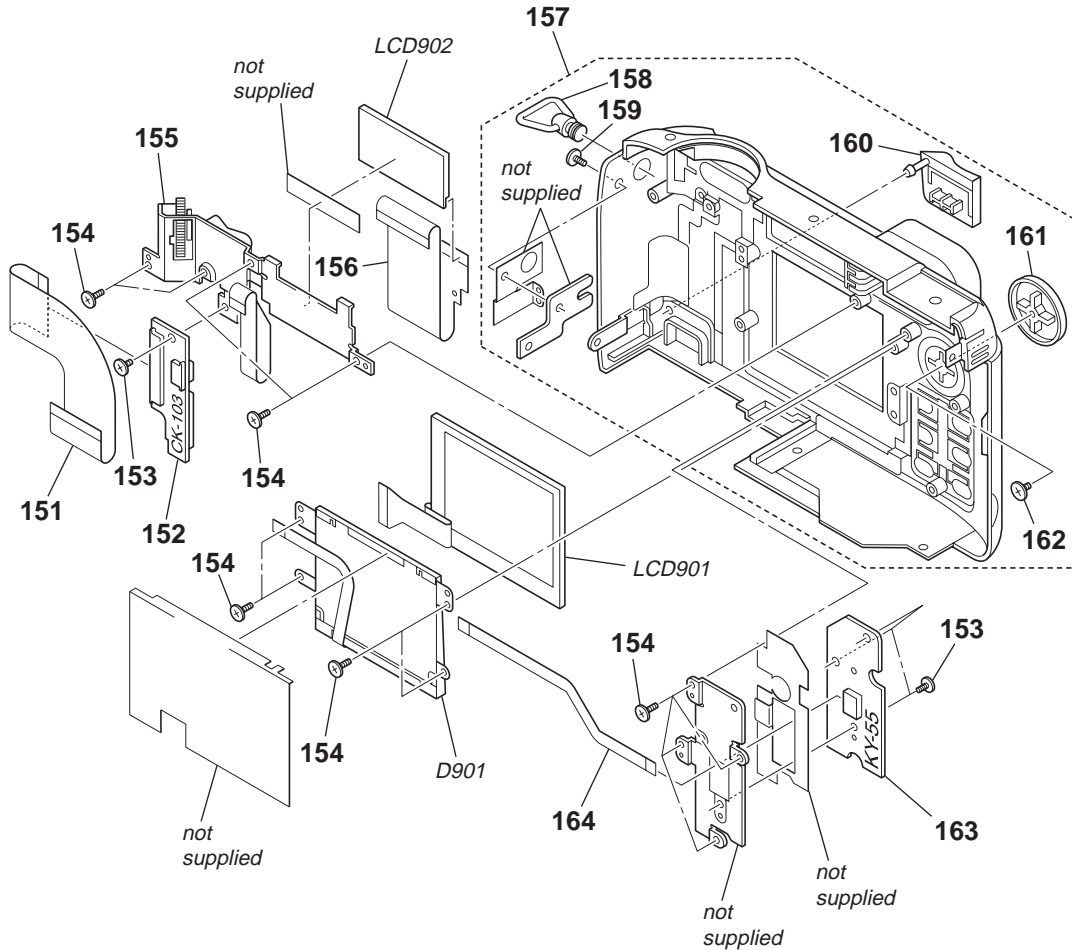

The components identified by mark  $\Delta$  or dotted line with mark  $\Delta$  are critical for safety. Replace only with part number specified.

Les composants identifiés par une marque  $\Delta$  sont critiques pour la sécurité. Ne les remplacer que par une pièce portant le numéro spécifié.

Ref. No.	Part No.	Description	Remark	Ref. No.	Part No.	Description	Remark
151	1-681-659-11	FP-038 FLEXIBLE BOARD		160	3-068-654-01	COVER, DC (IN)	
152	A-7074-852-A	CK-103 BOARD, COMPLETE		161	3-068-678-01	BUTTON, FUNCTION	
153	3-056-030-31	ACE (M1.7), O PLATE 2 MAIN LOCK		162	3-065-177-01	SCREW (1.7X3)	
154	3-713-791-71	SCREW (M1.7X4)		163	A-7074-851-A	KY-55 BOARD, COMPLETE	
155	1-476-667-11	SWITCH BLOCK, CONTROL (ZOOM)		164	1-681-660-11	FP-039 FLEXIBLE BOARD	
156	1-681-822-11	FP-389 FLEXIBLE BOARD		$\Delta$ D901	1-476-708-11	BLOCK, LIGHT GUIDE PLATE (1.8)	
157	X-3951-671-1	CABINET (REAR) ASSY		LCD901	1-804-337-21	INDICATOR MODULE, LIQUID CRYSTAL	
158	3-068-615-01	SHAFT (S), STRAP		LCD902	1-804-377-11	DISPLAY PANEL, LIQUID CRYSTAL	
159	3-069-158-11	PROCESS, (M2) INTERIOR LOCK				(CHARACTER DISPLAY)	

### 6-2. ELECTRICAL PARTS LIST

NOTE:

- Due to standardization, replacements in the parts list may be different from the parts specified in the diagrams or the components used on the set.
- -XX and -X mean standardized parts, so they may have some difference from the original one.
- RESISTORS  
All resistors are in ohms.  
METAL: Metal-film resistor.  
METAL OXIDE: Metal oxide-film resistor.  
F: nonflammable
- Abbreviation  
AUS : Australian model      J : Japanese model  
CN : Chinese model      JE : Tourist model  
CND : Canadian model      KR : Korea model  
HK : Hong Kong model

- Items marked “\*” are not stocked since they are seldom required for routine service. Some delay should be anticipated when ordering these items.
- SEMICONDUCTORS  
In each case, u:  $\mu$ , for example:  
uA. . :  $\mu$ A. .      uPA. . :  $\mu$ PA. .  
uPB. . :  $\mu$ PB. .      uPC. . :  $\mu$ PC. .  
uPD. . :  $\mu$ PD. .
- CAPACITORS  
uF:  $\mu$ F  
• COILS  
uH:  $\mu$ H

The components identified by mark  $\Delta$  or dotted line with mark  $\Delta$  are critical for safety. Replace only with part number specified.

Les composants identifiés par une marque  $\Delta$  sont critiques pour la sécurité. Ne les remplacer que par une pièce portant le numéro spécifié.

When indicating parts by reference number, please include the board.

Ref. No.	Part No.	Description	Remark	Ref. No.	Part No.	Description	Remark
	A-7074-852-A	CK-103 BOARD, COMPLETE ***** (Ref.No.: 2,000 Series)		C036	1-115-566-11	CERAMIC CHIP 4.7uF 10%	10V
		< CONNECTOR >		C037	1-115-566-11	CERAMIC CHIP 4.7uF 10%	10V
CN961	1-794-766-21	CONNECTOR, FFC/FPC (LIF) 6P		C039	1-104-851-11	TANTAL. CHIP 10uF 20%	10V
CN962	1-794-770-21	CONNECTOR, FFC/FPC (LIF) 24P		C040	1-164-506-11	CERAMIC CHIP 4.7uF	16V
CN963	1-815-598-11	CONNECTOR, FFC/FPC (ZIF) 34P		C041	1-164-506-11	CERAMIC CHIP 4.7uF	16V
CN964	1-794-322-11	CONNECTOR, FFC/FPC (ZIF) 6P		C042	1-104-851-11	TANTAL. CHIP 10uF 20%	10V
				C043	1-135-259-11	TANTAL. CHIP 10uF 20%	6.3V
	A-7074-849-A	DM-101 BOARD, COMPLETE ***** (Ref.No.: 2,000 Series)		C044	1-127-760-11	CERAMIC CHIP 4.7uF 10%	6.3V
		< CAPACITOR >		C045	1-135-259-11	TANTAL. CHIP 10uF 20%	6.3V
C001	1-164-880-11	CERAMIC CHIP 180PF 5% 16V		C046	1-135-201-11	TANTALUM CHIP 10uF 20%	4V
C002	1-110-563-11	CERAMIC CHIP 0.068uF 10% 16V		C047	1-135-259-11	TANTAL. CHIP 10uF 20%	6.3V
C003	1-164-677-11	CERAMIC CHIP 0.033uF 10% 16V		C048	1-164-506-11	CERAMIC CHIP 4.7uF	16V
C004	1-125-777-11	CERAMIC CHIP 0.1uF 10% 10V		C049	1-165-319-11	CERAMIC CHIP 0.1uF	50V
C005	1-125-837-91	CERAMIC CHIP 1uF 10% 6.3V		C050	1-113-987-11	TANTAL. CHIP 4.7uF 20%	25V
C008	1-164-938-11	CERAMIC CHIP 0.0015uF 10% 16V		C051	1-165-319-11	CERAMIC CHIP 0.1uF	50V
C009	1-107-819-11	CERAMIC CHIP 0.022uF 10% 16V		C053	1-115-566-11	CERAMIC CHIP 4.7uF 10%	10V
C010	1-164-943-11	CERAMIC CHIP 0.01uF 10% 16V		C055	1-128-643-11	CERAMIC CHIP 4.7uF (3216)	
C011	1-164-938-11	CERAMIC CHIP 0.0015uF 10% 16V		C057	1-125-838-11	CERAMIC CHIP 2.2uF 10%	6.3V
C013	1-164-940-11	CERAMIC CHIP 0.0033uF 10% 16V		C065	1-107-823-11	CERAMIC CHIP 0.47uF 10%	16V
C014	1-164-943-11	CERAMIC CHIP 0.01uF 10% 16V		C068	1-104-913-11	TANTAL. CHIP 10uF 20%	16V
C015	1-107-819-11	CERAMIC CHIP 0.022uF 10% 16V		C069	1-107-682-11	CERAMIC CHIP 1uF 10%	16V
C018	1-164-937-11	CERAMIC CHIP 0.001uF 10% 16V		C070	1-164-937-11	CERAMIC CHIP 0.001uF 10%	16V
C019	1-164-937-11	CERAMIC CHIP 0.001uF 10% 16V		C753	1-107-826-11	CERAMIC CHIP 0.1uF 10%	16V
C020	1-104-913-11	TANTAL. CHIP 10uF 20% 16V				< CONNECTOR >	
C021	1-164-937-11	CERAMIC CHIP 0.001uF 10% 16V		* CN001	1-580-056-21	PIN, CONNECTOR (SMD) 3P	
C023	1-164-937-11	CERAMIC CHIP 0.001uF 10% 16V		* CN002	1-580-056-21	PIN, CONNECTOR (SMD) 3P	
C024	1-104-913-11	TANTAL. CHIP 10uF 20% 16V		CN004	1-774-054-21	CONNECTOR, FFC/FPC (ZIF) 45P	
C025	1-104-913-11	TANTAL. CHIP 10uF 20% 16V		CN751	1-766-354-21	CONNECTOR, FFC/FPC 24P	
C026	1-164-937-11	CERAMIC CHIP 0.001uF 10% 16V		CN752	1-766-340-21	CONNECTOR, FFC/FPC 10P	
C027	1-164-937-11	CERAMIC CHIP 0.001uF 10% 16V		CN753	1-815-572-11	CONNECTOR, MEMORY STICK (MS SOCKET)	
C028	1-104-913-11	TANTAL. CHIP 10uF 20% 16V		CN754	1-766-336-21	CONNECTOR, FFC/FPC 6P	
C029	1-128-643-11	CERAMIC CHIP 4.7uF (3216)				< DIODE >	
C030	1-115-566-11	CERAMIC CHIP 4.7uF 10% 10V		D001	8-719-075-15	DIODE MAZT082H08S0	
C031	1-115-566-11	CERAMIC CHIP 4.7uF 10% 10V		D002	8-719-158-49	DIODE MA8120-TX	
C032	1-115-566-11	CERAMIC CHIP 4.7uF 10% 10V		D003	8-719-027-76	DIODE 1SS357-TPH3	
C034	1-127-760-11	CERAMIC CHIP 4.7uF 10% 6.3V		D004	8-719-027-76	DIODE 1SS357-TPH3	
C035	1-115-566-11	CERAMIC CHIP 4.7uF 10% 10V		D005	8-719-027-77	DIODE MA796-TX	
				D006	8-719-073-01	DIODE MA111- (K8).S0	
				D007	8-719-073-01	DIODE MA111- (K8).S0	
				D008	8-719-058-24	DIODE RB501V-40TE-17	

# DM-101

Ref. No.	Part No.	Description	Remark	Ref. No.	Part No.	Description	Remark
D751	8-719-073-01	DIODE MA111- (K8).SO		R008	1-218-953-11	RES-CHIP 1K	5% 1/16W
D755	8-719-066-44	DIODE CL-270HR-C-TS (ACCESS)		R009	1-208-719-11	METAL CHIP 33K	0.5% 1/16W
		< FUSE >		R010	1-218-973-11	RES-CHIP 47K	5% 1/16W
△ F001	1-576-406-11	FUSE, MICRO (1608) (1.4A/32V)		R011	1-218-971-11	RES-CHIP 33K	5% 1/16W
△ F002	1-576-406-11	FUSE, MICRO (1608) (1.4A/32V)		R012	1-208-909-11	METAL CHIP 8.2K	0.5% 1/16W
△ F003	1-576-406-11	FUSE, MICRO (1608) (1.4A/32V)		R013	1-218-969-11	RES-CHIP 22K	5% 1/16W
△ F004	1-576-406-11	FUSE, MICRO (1608) (1.4A/32V)		R014	1-218-985-11	RES-CHIP 470K	5% 1/16W
△ F005	1-576-406-11	FUSE, MICRO (1608) (1.4A/32V)		R015	1-218-989-11	RES-CHIP 1M	5% 1/16W
		< FERRITE BEAD >		R016	1-218-963-11	RES-CHIP 6.8K	5% 1/16W
FB001	1-414-228-11	FERRITE 0uH		R017	1-218-966-11	RES-CHIP 12K	5% 1/16W
FB002	1-414-228-11	FERRITE 0uH		R018	1-216-150-91	RES-CHIP 10	5% 1/8W
		< IC >		R019	1-208-719-11	METAL CHIP 33K	0.5% 1/16W
IC001	8-759-491-22	IC MB3825APFV-G-BND-ER		R020	1-208-699-11	METAL CHIP 4.7K	0.5% 1/16W
		< COIL >		R021	1-208-701-11	METAL CHIP 5.6K	0.5% 1/16W
L006	1-416-669-11	INDUCTOR 22uH		R022	1-208-719-11	METAL CHIP 33K	0.5% 1/16W
L010	1-412-056-11	INDUCTOR 4.7uH		R023	1-208-695-11	METAL CHIP 3.3K	0.5% 1/16W
L011	1-412-056-11	INDUCTOR 4.7uH		R024	1-218-953-11	RES-CHIP 1K	5% 1/16W
L012	1-412-056-11	INDUCTOR 4.7uH		R025	1-218-963-11	RES-CHIP 6.8K	5% 1/16W
L013	1-412-056-11	INDUCTOR 4.7uH		R026	1-218-990-11	SHORT 0	
L014	1-412-056-11	INDUCTOR 4.7uH		R027	1-208-707-11	METAL CHIP 10K	0.5% 1/16W
L015	1-416-669-11	INDUCTOR 22uH		R028	1-218-970-11	METAL CHIP 27K	0.5% 1/16W
L016	1-412-056-11	INDUCTOR 4.7uH		R029	1-208-927-11	METAL CHIP 47K	0.5% 1/16W
L017	1-414-406-41	INDUCTOR 220uH		R030	1-208-711-11	METAL CHIP 15K	0.5% 1/16W
L018	1-419-387-11	INDUCTOR 100uH		R031	1-208-715-11	METAL CHIP 22K	0.5% 1/16W
L019	1-216-296-11	SHORT 0 (Note)		R032	1-218-965-11	RES-CHIP 10K	5% 1/16W
		< LINE FILTER >		R033	1-218-958-11	METAL CHIP 2.7K	0.5% 1/16W
LF001	1-411-957-11	FILTER, COMMON MODE		R034	1-208-707-11	METAL CHIP 10K	0.5% 1/16W
		< TRANSISTOR >		R035	1-218-959-11	RES-CHIP 3.3K	5% 1/16W
Q001	8-729-047-68	TRANSISTOR SSM3K03FE (TPL3)		R036	1-208-719-11	METAL CHIP 33K	0.5% 1/16W
Q002	8-729-051-49	TRANSISTOR TPC8305 (TE12L)		R037	1-208-695-11	METAL CHIP 3.3K	0.5% 1/16W
Q003	8-729-804-41	TRANSISTOR 2SB1122-ST-TD		R038	1-208-695-11	METAL CHIP 3.3K	0.5% 1/16W
Q004	8-729-037-74	TRANSISTOR UN9213J- (K8).SO		R040	1-218-971-11	RES-CHIP 33K	5% 1/16W
Q005	8-729-804-41	TRANSISTOR 2SB1122-ST-TD		R041	1-208-721-11	METAL CHIP 39K	0.5% 1/16W
Q006	8-729-033-14	TRANSISTOR FP107-TL		R042	1-218-971-11	RES-CHIP 33K	5% 1/16W
Q007	8-729-033-14	TRANSISTOR FP107-TL		R043	1-218-990-11	SHORT 0	
Q008	8-729-043-60	TRANSISTOR CPH6102-TL		R044	1-218-990-11	SHORT 0	
Q009	8-729-033-14	TRANSISTOR FP107-TL		R045	1-218-990-11	SHORT 0	
Q011	8-729-033-14	TRANSISTOR FP107-TL		R046	1-218-971-11	RES-CHIP 33K	5% 1/16W
Q012	8-729-044-58	TRANSISTOR SI2304DS-T1		R047	1-218-969-11	RES-CHIP 22K	5% 1/16W
Q014	8-729-042-26	TRANSISTOR 2SB1462J-QR (K8).SO		R048	1-218-990-11	SHORT 0	
Q067	8-729-053-54	TRANSISTOR N1A01FE-Y/GR (TPLR3)		R049	1-218-990-11	SHORT 0	
Q070	8-729-053-54	TRANSISTOR N1A01FE-Y/GR (TPLR3)		R050	1-218-990-11	SHORT 0	
Q073	8-729-053-52	TRANSISTOR N1C01FE-Y/GR (TPLR3)		R051	1-218-969-11	RES-CHIP 22K	5% 1/16W
Q076	8-729-037-52	TRANSISTOR 2SD2216J-QR (K8).SO		R052	1-218-971-11	RES-CHIP 33K	5% 1/16W
		< RESISTOR >		R053	1-218-969-11	RES-CHIP 22K	5% 1/16W
R001	1-208-713-11	METAL CHIP 18K	0.5% 1/16W	R054	1-218-977-11	RES-CHIP 100K	5% 1/16W
R003	1-208-920-81	METAL CHIP 24K	0.5% 1/16W	R055	1-208-719-11	METAL CHIP 33K	0.5% 1/16W
R004	1-218-971-11	RES-CHIP 33K	5% 1/16W	R056	1-208-713-11	METAL CHIP 18K	0.5% 1/16W
R005	1-218-979-11	RES-CHIP 150K	5% 1/16W	R057	1-208-719-11	METAL CHIP 33K	0.5% 1/16W
R007	1-216-295-11	SHORT 0		R058	1-208-935-11	METAL CHIP 100K	0.5% 1/16W
				R059	1-218-990-11	SHORT 0	
				R071	1-218-967-11	RES-CHIP 15K	5% 1/16W
				R072	1-218-977-11	RES-CHIP 100K	5% 1/16W
				R074	1-208-933-11	METAL CHIP 82K	0.5% 1/16W
				R076	1-218-977-11	RES-CHIP 100K	5% 1/16W
				R077	1-218-977-11	RES-CHIP 100K	5% 1/16W
				R082	1-218-965-11	RES-CHIP 10K	5% 1/16W
				R084	1-208-931-11	METAL CHIP 68K	0.5% 1/16W

Note: Resistor is mounted to the location where L019 is printed.

The components identified by mark △ or dotted line with mark △ are critical for safety. Replace only with part number specified.

Les composants identifiés par une marque △ sont critiques pour la sécurité. Ne les remplacer que par une pièce portant le numéro spécifié.

Ref. No.	Part No.	Description	Remark
R085	1-208-715-11	METAL CHIP 22K	0.5% 1/16W
R086	1-208-713-11	METAL CHIP 18K	0.5% 1/16W
R087	1-218-978-11	METAL CHIP 120K	0.5% 1/16W
R088	1-208-689-11	METAL CHIP 1.8K	0.5% 1/16W
R089	1-208-707-11	METAL CHIP 10K	0.5% 1/16W
R751	1-218-955-11	RES-CHIP 1.5K	5% 1/16W
R752	1-218-945-11	RES-CHIP 220	5% 1/16W
R753	1-218-990-11	SHORT 0	
< TRANSFORMER >			
$\Delta$ T001	1-429-565-21	TRANSFORMER, CONVERTER	

## A-7074-850-A JK-211 BOARD, COMPLETE

\*\*\*\*\*

(Ref.No.: 2,000 Series)

&lt; BATTERY &gt;

BT901 1-756-191-11 BATTERY, LITHIUM (SECONDARY)

&lt; CAPACITOR &gt;

C901 1-164-874-11 CERAMIC CHIP 100PF 5% 16V  
C903 1-216-864-91 SHORT 0 (Note)

&lt; CONNECTOR &gt;

CN901 1-766-348-21 CONNECTOR, FFC/FPC 18P  
CN902 1-794-962-11 CONNECTOR, SQUARE TYPE (USB 5P) (USB)

&lt; DIODE &gt;

D901 8-719-075-15 DIODE MAZT082H08S0  
D902 8-719-075-15 DIODE MAZT082H08S0  
D903 8-719-075-15 DIODE MAZT082H08S0  
D904 8-719-075-15 DIODE MAZT082H08S0  
D905 8-719-075-15 DIODE MAZT082H08S0  
D907 8-719-075-15 DIODE MAZT082H08S0  
D908 8-719-075-15 DIODE MAZT082H08S0  
D909 8-719-075-15 DIODE MAZT082H08S0  
D910 8-719-075-15 DIODE MAZT082H08S0  
D911 8-719-073-01 DIODE MA111- (K8).S0  
D912 8-719-073-01 DIODE MA111- (K8).S0

&lt; FERRITE BEAD &gt;

FB901 1-216-864-91 SHORT 0 (Note)  
FB902 1-469-324-21 FERRITE 0uH  
FB903 1-469-179-21 FERRITE 0uH  
FB904 1-469-179-21 FERRITE 0uH  
FB905 1-469-179-21 FERRITE 0uH  
FB906 1-469-179-21 FERRITE 0uH  
FB907 1-469-324-21 FERRITE 0uH  
FB908 1-500-284-21 FERRITE 0uH  
FB909 1-500-284-21 FERRITE 0uH

&lt; JACK &gt;

J901 1-793-995-21 JACK, SUPER SMALL TYPE (ACC)  
J902 1-569-950-31 JACK (SMALL TYPE) (A/V OUT)

Ref. No.	Part No.	Description	Remark
< LINE FILTER >			
LF901	1-419-100-21	COIL, COMMON-MODE CHOKE	
< RESISTOR >			
R901	1-218-979-11	RES-CHIP 150K	5% 1/16W
R902	1-218-985-11	RES-CHIP 470K	5% 1/16W
R903	1-218-953-11	RES-CHIP 1K	5% 1/16W
R904	1-218-977-11	RES-CHIP 100K	5% 1/16W
R905	1-216-013-00	METAL CHIP 33	5% 1/10W
R906	1-216-295-11	SHORT 0	
R908	1-216-295-11	SHORT 0	

## A-7074-851-A KY-55 BOARD, COMPLETE

\*\*\*\*\*

(Ref.No.: 2,000 Series)

&lt; CONNECTOR &gt;

CN931 1-815-597-11 CONNECTOR, FFC (ZIF) 6P

&lt; DIODE &gt;

D931 8-719-073-01 DIODE MA111- (K8).S0  
D932 8-719-075-15 DIODE MAZT082H08S0  
D933 8-719-075-15 DIODE MAZT082H08S0  
D934 8-719-075-15 DIODE MAZT082H08S0

&lt; RESISTOR &gt;

R931 1-218-954-11 RES-CHIP 1.2K 5% 1/16W  
R932 1-218-954-11 RES-CHIP 1.2K 5% 1/16W  
R933 1-218-955-11 RES-CHIP 1.5K 5% 1/16W  
R934 1-218-955-11 RES-CHIP 1.5K 5% 1/16W  
R935 1-218-954-11 RES-CHIP 1.2K 5% 1/16W  
R936 1-218-955-11 RES-CHIP 1.5K 5% 1/16W  
R937 1-218-959-11 RES-CHIP 3.3K 5% 1/16W  
R938 1-218-963-11 RES-CHIP 6.8K 5% 1/16W

&lt; SWITCH &gt;

S931 1-771-138-82 SWITCH, KEY BOARD (AE LOCK)  
S932 1-771-138-82 SWITCH, KEY BOARD (DSPL/LCD ON/OFF)  
S933 1-786-039-21 SWITCH, TACTILE (CONTROL)  
S934 1-771-138-82 SWITCH, KEY BOARD (  $\pm$  )  
S935 1-771-138-82 SWITCH, KEY BOARD (AF/MF)  
S936 1-771-138-82 SWITCH, KEY BOARD (MENU)  
S937 1-771-138-82 SWITCH, KEY BOARD (  $\bullet$  )

Electrical parts list of the SY-68 board is not shown.

Pages 6-8 to 6-13 are not shown.

Note: Resistor is mounted to the location where C903 and FB901 are printed.

The components identified by mark  $\Delta$  or dotted line with mark  $\Delta$  are critical for safety. Replace only with part number specified.Les composants identifiés par une marque  $\Delta$  sont critiques pour la sécurité. Ne les remplacer que par une pièce portant le numéro spécifié.

<u>Ref. No.</u>	<u>Part No.</u>	<u>Description</u>	<u>Remark</u>
		ACCESSORIES *****	
△	1-475-599-11	ADAPTOR, AC (AC-L10) (EXCEPT CN, KR)	
△	1-475-599-71	ADAPTOR, AC (AC-L10) (KR)	
△	1-475-599-81	ADAPTOR, AC (AC-L10) (CN)	
△	1-569-007-11	ADAPTOR, CONVERSION 2P (E, JE)	
△	1-569-008-21	ADAPTOR, CONVERSION 2P (E)	
△	1-696-819-11	CORD, POWER (AUS)	
	1-757-293-11	CORD, CONNECTION (USB 5P)	
△	1-769-608-11	CORD, POWER (AEP, E)	
△	1-776-985-11	CORD, POWER (KR)	
△	1-782-476-11	CORD, POWER (CN)	
△	1-783-374-11	CORD, POWER (UK, HK)	
	1-783-738-31	CORD, CONNECTION (AV CONNECTING 1.5m)	
△	1-790-073-11	CORD, POWER 2P (JE)	
△	1-790-107-22	CORD, POWER (US, CND)	
△	1-790-732-11	CORD, POWER (J)	
	3-065-665-01	MANUAL, INSTRUCTION (for SAFETY) (JAPANESE) (J)	
	3-066-676-01	SPVD-004 (P) (CD-ROM) (EXCEPT US, CND, J)	
	3-066-677-01	SPVD-004 (I) (CD-ROM) (US, CND, J)	
	3-067-652-01	REGISTRATION (CD-ROM) (J)	
	3-067-797-01	STRING (T), CAP	
	3-068-121-01	CLUB (J), PICTURE PARADISE (CD-ROM) (J)	
	3-068-187-01	MANUAL, INSTRUCTION (JAPANESE) (J)	
	3-068-187-11	MANUAL, INSTRUCTION (ENGLISH) (US, CND, AEP, UK, E, AUS, CN, HK, JE)	
	3-068-187-21	MANUAL, INSTRUCTION (FRENCH, GERMAN) (CND, AEP, JE)	
	3-068-187-31	MANUAL, INSTRUCTION (SPANISH, PORTUGUESE) (AEP, E, JE)	
	3-068-187-41	MANUAL, INSTRUCTION (DUTCH, ITALIAN) (AEP)	
	3-068-187-51	MANUAL, INSTRUCTION (TRADITIONAL CHINESE, SIMPLIFIED CHINESE) (E, CN, HK, JE)	
	3-068-187-61	MANUAL, INSTRUCTION (SWEDISH, RUSSIAN) (AEP, JE)	
	3-068-187-71	MANUAL, INSTRUCTION (ARABIC) (E)	
	3-068-187-81	MANUAL, INSTRUCTION (KOREAN) (KR, JE)	
	3-068-191-01	PC INSTRUCTION MANUAL (JAPANESE) (J)	
	3-987-015-01	BELT (S), SHOULDER	
	X-3951-672-1	CAP ASSY, LENS	

# FOR CAMERA COLOR REPRODUCTION ADJUSTMENT

Take a copy of CAMERA COLOR REPRODUCTION FRAME with a clear sheet for use.

For NTSC mode

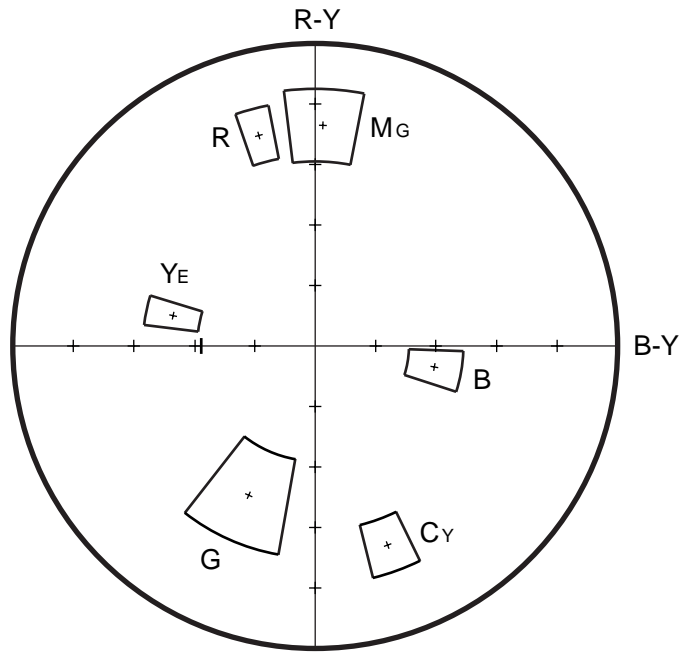

DSC-S75





# DSC-S75

**SONY®**

## **SERVICE MANUAL**

Level 2

2001. 11

*US Model*  
*Canadian Model*  
*AEP Model*  
*UK Model*  
*E Model*  
*Hong Kong Model*  
*Australian Model*  
*Chinese Model*  
*Korea Model*  
*Tourist Model*  
*Japanese Model*

## **SUPPLEMENT-1**

File this supplement with the service manual.  
(PV01-024)

• Change of Service Parts.



