

# DSC-S730

## SERVICE MANUAL

Ver. 1.0 2007.11

Revision History

Internal memory  
ON BOARD



*US Model  
Canadian Model  
AEP Model  
UK Model  
E Model  
Australian Model  
Hong Kong Model  
Chinese Model  
Korea Model  
Tourist Model*

### Link

• SPECIFICATIONS

• DISASSEMBLY

• REPAIR PARTS LIST

• SERVICE NOTE

• BLOCK DIAGRAM

The components identified by mark  $\triangle$  or dotted line with mark  $\triangle$  are critical for safety. Replace only with part number specified.

Les composants identifiés par une marque  $\triangle$  sont critiques pour la sécurité. Ne les remplacer que par une pièce portant le numéro spécifié.

In case of the lens block assy, main board, or main frame assembly failure, contact your local Sony Service Headquarter for the measures.

DIGITAL STILL CAMERA

**SONY**<sup>®</sup>

Cyber-shot



## SPECIFICATIONS

### [System]

Image device: 7.20 mm (1/2.5 type) color CCD,  
Primary color filter  
Total pixel number of camera:  
Approx. 7 410 000 pixels  
Effective pixel number of camera:  
Approx. 7 201 000 pixels  
Lens: 3× zoom lens  $f = 5.8 - 17.4$  mm (35 –  
105 mm when converted to a 35 mm still  
camera) F2.8 (W) – 4.8 (T)  
Exposure control: Automatic exposure, Scene  
Selection (7 modes)  
White balance: Automatic, Daylight, Cloudy,  
Fluorescent, Incandescent, Flash  
File format (DCF compliant):  
Still images: Exif Ver. 2.21 JPEG compliant,  
DPOF compatible  
Movies: AVI (Motion JPEG)  
Recording media: Internal Memory (approx.  
22 MB), "Memory Stick Duo"  
Flash: Flash range (ISO sensitivity  
(Recommended Exposure Index) set to Auto):  
approx. 0.5 to 3.5 m (1 feet 7 3/4 inches to 11  
feet 5 7/8 inches) (W)/approx. 0.5 to 2.0 m (1  
feet 7 3/4 inches to 6 feet 6 3/4 inches) (T)

### [Input and Output connectors]

• (USB) • A/V OUT terminal:  
Video, Audio (Monaural), USB  
communication  
USB communication:  
Hi-Speed USB (USB 2.0 compliant)

### [LCD screen]

LCD panel: 6.0 cm (2.4 type) TFT drive  
Total number of dots: 112 320 (480×234) dots

### [Power, general]

Power: LR6 (size AA) Alkaline batteries (2), 3 V  
HR15/51:HR6 (size AA) Nickel-Metal  
Hydride batteries (2) (not supplied), 2.4 V  
ZR6 (size AA) Oxy Nickel Primary Battery  
(2) (not supplied), 3 V  
AC-LS5K AC Adaptor (not supplied), 4.2 V  
Power consumption (during shooting): 1.2 W  
Operating temperature: 0 to 40°C (32 to 104°F)  
Storage temperature: -20 to +60°C (-4 to +140°F)  
Dimensions: 91.4×61.0×29.1 mm (3 5/8×2 1/2×  
1 3/16 inches) (W/H/D, excluding  
protrusions)  
Mass: Approx. 189 g (6.7 oz) (including two  
batteries and strap, etc.)  
Microphone: Monaural  
Buzzer  
Exif Print: Compatible  
PRINT Image Matching III: Compatible  
PictBridge: Compatible

Design and specifications are subject to change  
without notice.

**CAUTION**

Danger of explosion if battery is incorrectly replaced.  
Replace only with the same or equivalent type.

**SAFETY-RELATED COMPONENT WARNING!!**

**COMPONENTS IDENTIFIED BY MARK  $\triangle$  OR DOTTED LINE WITH MARK  $\triangle$  ON THE SCHEMATIC DIAGRAMS AND IN THE PARTS LIST ARE CRITICAL TO SAFE OPERATION. REPLACE THESE COMPONENTS WITH SONY PARTS WHOSE PART NUMBERS APPEAR AS SHOWN IN THIS MANUAL OR IN SUPPLEMENTS PUBLISHED BY SONY.**

**ATTENTION AU COMPOSANT AYANT RAPPORT  
À LA SÉCURITÉ!**

**LES COMPOSANTS IDENTIFIÉS PAR UNE MARQUE  $\triangle$  SUR LES DIAGRAMMES SCHÉMATIQUES ET LA LISTE DES PIÈCES SONT CRITIQUES POUR LA SÉCURITÉ DE FONCTIONNEMENT. NE REMPLACER CES COMPOSANTS QUE PAR DES PIÈSES SONY DONT LES NUMÉROS SONT DONNÉS DANS CE MANUEL OU DANS LES SUPPLÉMENTS PUBLIÉS PAR SONY.**

## SAFETY CHECK-OUT

After correcting the original service problem, perform the following safety checks before releasing the set to the customer.

1. Check the area of your repair for unsoldered or poorly-soldered connections. Check the entire board surface for solder splashes and bridges.
2. Check the interboard wiring to ensure that no wires are "pinched" or contact high-wattage resistors.
3. Look for unauthorized replacement parts, particularly transistors, that were installed during a previous repair. Point them out to the customer and recommend their replacement.
4. Look for parts which, through functioning, show obvious signs of deterioration. Point them out to the customer and recommend their replacement.
5. Check the B+ voltage to see it is at the values specified.
6. FLEXIBLE Circuit Board Repairing
  - Keep the temperature of the soldering iron around 270°C during repairing.
  - Do not touch the soldering iron on the same conductor of the circuit board (within 3 times).
  - Be careful not to apply force on the conductor when soldering or unsoldering.

### Unleaded solder

Boards requiring use of unleaded solder are printed with the lead-free mark (LF) indicating the solder contains no lead.  
(Caution: Some printed circuit boards may not come printed with the lead free mark due to their particular size.)



### **LF : LEAD FREE MARK**

Unleaded solder has the following characteristics.

- Unleaded solder melts at a temperature about 40°C higher than ordinary solder.  
Ordinary soldering irons can be used but the iron tip has to be applied to the solder joint for a slightly longer time.  
Soldering irons using a temperature regulator should be set to about 350°C.  
Caution: The printed pattern (copper foil) may peel away if the heated tip is applied for too long, so be careful!
- Strong viscosity  
Unleaded solder is more viscous (sticky, less prone to flow) than ordinary solder so use caution not to let solder bridges occur such as on IC pins, etc.
- Usable with ordinary solder  
It is best to use only unleaded solder but unleaded solder may also be added to ordinary solder.

## TABLE OF CONTENTS

<i>Section</i>	<i>Title</i>	<i>Page</i>
<b>1. SERVICE NOTE</b>		
1-1.	Process After Fixing Flash Error .....	1-1
1-2.	Method for Copying or Erasing the Data in Internal Memory .....	1-1
<b>2. DISASSEMBLY</b>		
2-1.	Disassembly .....	2-1
<b>3. BLOCK DIAGRAM</b>		
3-1.	Overall Block Diagram .....	3-1
<b>4. REPAIR PARTS LIST</b>		
4-1.	Exploded Views .....	4-1
4-1-1.	Overall Section .....	4-1
4-1-2.	Main Frame Block .....	4-2
4-2.	Accessories .....	4-3

# 1. SERVICE NOTE

## 1-1. PROCESS AFTER FIXING FLASH ERROR

### Method for Initializing the Flash Error

#### Initialize

Initializes the setting to the default setting.

Even if you execute this function, the images stored in the internal memory are retained.

- ① Select [OK] with ▲ on the control button, then press ●.  
The message "Initialize all settings Ready?" appears.
- ② Select [OK] with ▲, then press ●.  
The settings are reset to the default setting.

#### To cancel initializing

Select [Cancel] in step ① or ②, then press ●.

- Be sure not to power off the camera while initializing.

## 1-2. METHOD FOR COPYING OR ERASING THE DATA IN INTERNAL MEMORY

The data can be copied/erased by the operations on the Setup screen. (When erasing the data, execute formatting the internal memory.)

**Note:** When replacing the camera, erase the data in internal memory of the board before replacement.

### Method for Copying the Data in Internal Memory

#### Copy

Copies all images in the internal memory to a "Memory Stick Duo".

- ① Insert a "Memory Stick Duo" having sufficient free capacity.
- ② Select [OK] with ▲ on the control button, then press ●.  
The message "All data in internal memory will be copied Ready?" appears.
- ③ Select [OK] with ▲, then press ●.  
Copying starts.

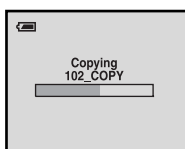

#### To cancel copying

Select [Cancel] in step ② or ③, then press ●.

- Use batteries with enough power remaining. If you attempt to copy image files using batteries with little remaining charge, the batteries may run out, causing copying to fail or possibly corrupting the data.
- You cannot select images to copy.
- The original images in the internal memory are retained even after copying. To delete the contents of the internal memory, remove the "Memory Stick Duo" after copying, then format the internal memory ([Format] in [Internal Memory Tool]).
- A new folder is created on the "Memory Stick Duo" and all the data will be copied to it. You cannot choose a specific folder and copy images to it.
- The  (Print order) marks on the images are not copied.

### Method for Formatting the Internal Memory

This item does not appear when a "Memory Stick Duo" is inserted in the camera.

#### Format

Formats the internal memory.

- Note that formatting permanently erases all data in the internal memory, including even protected images.

- ① Select [OK] with ▲ on the control button, then press ●.  
The message "All data in internal memory will be erased Ready?" appears.
- ② Select [OK] with ▲, then press ●.  
The format is complete.

#### To cancel formatting

Select [Cancel] in step ① or ②, then press ●.

## 2. DISASSEMBLY

The following flow chart shows the disassembly procedure.

### 2-1. DISASSEMBLY

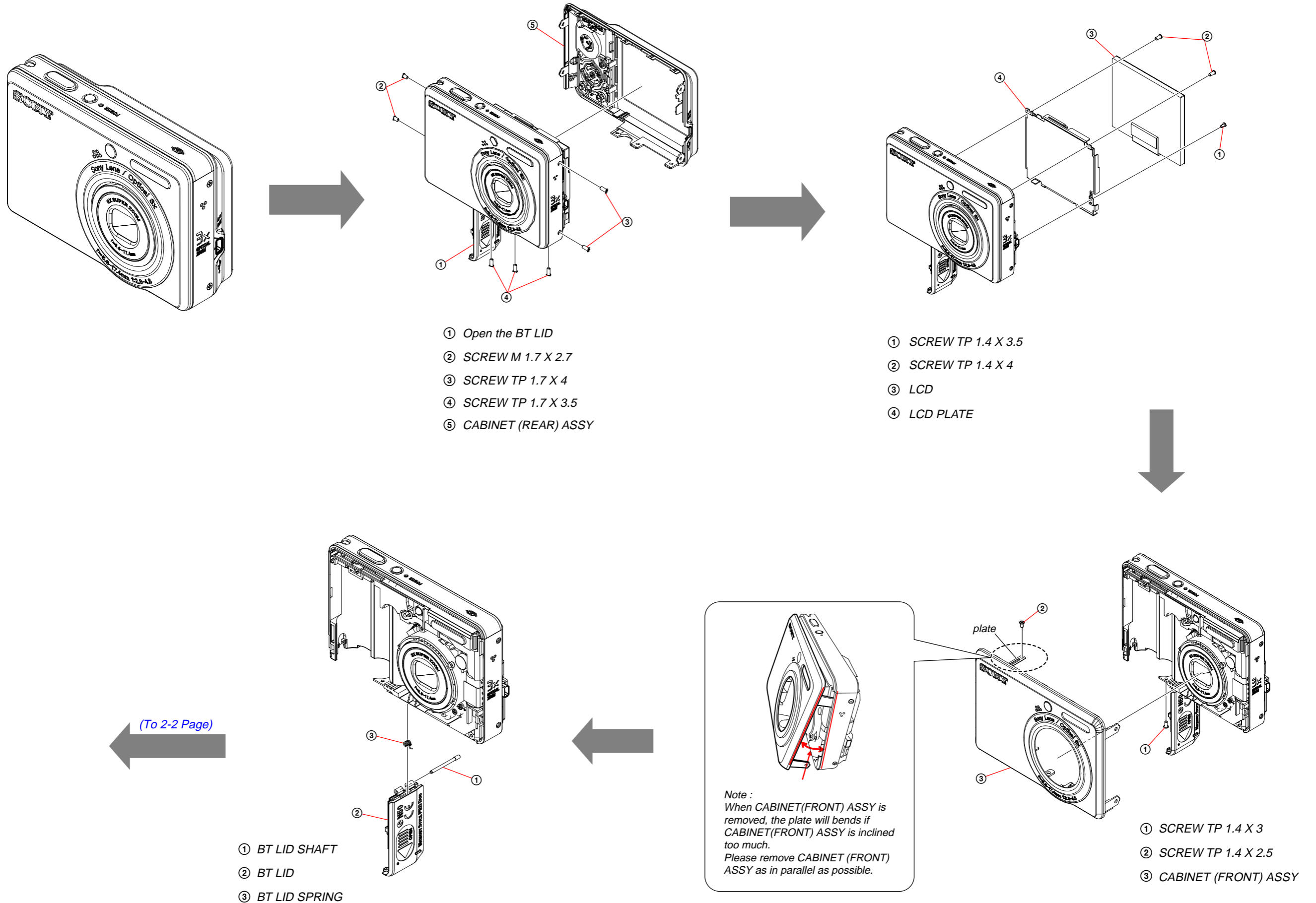

(From 2-1 Page)



**Caution**

Shorting jig  
(1kΩ / 1W)

Note :  
After discharged, a transparent seal is put again.  
Do not lose the transparent seal removed when discharged.

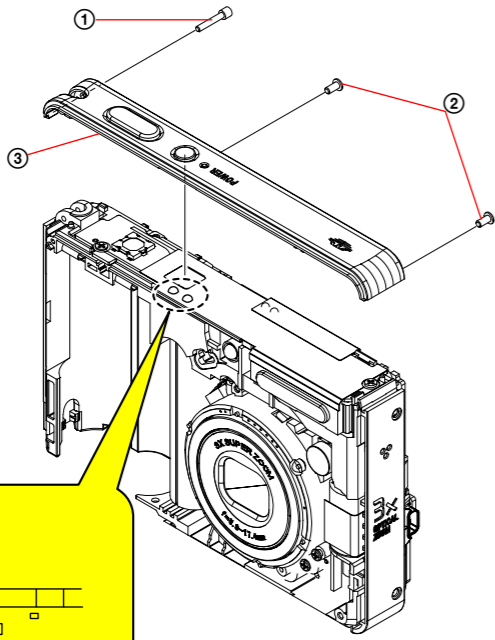

- ① STRAP SHAFT
- ② SCREW TP 1.4 X 3
- ③ RL BLOCK

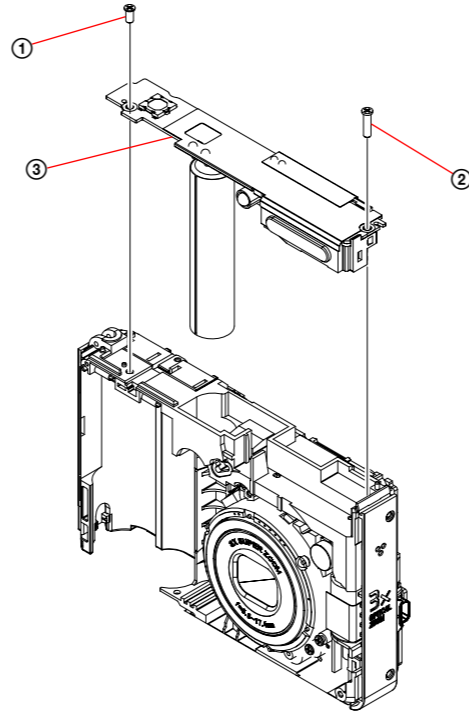

- ① SCREW TP 1.7 X 3.5
- ② SCREW TP 1.7 X 6.5
- ③ ST BLOCK ASSY

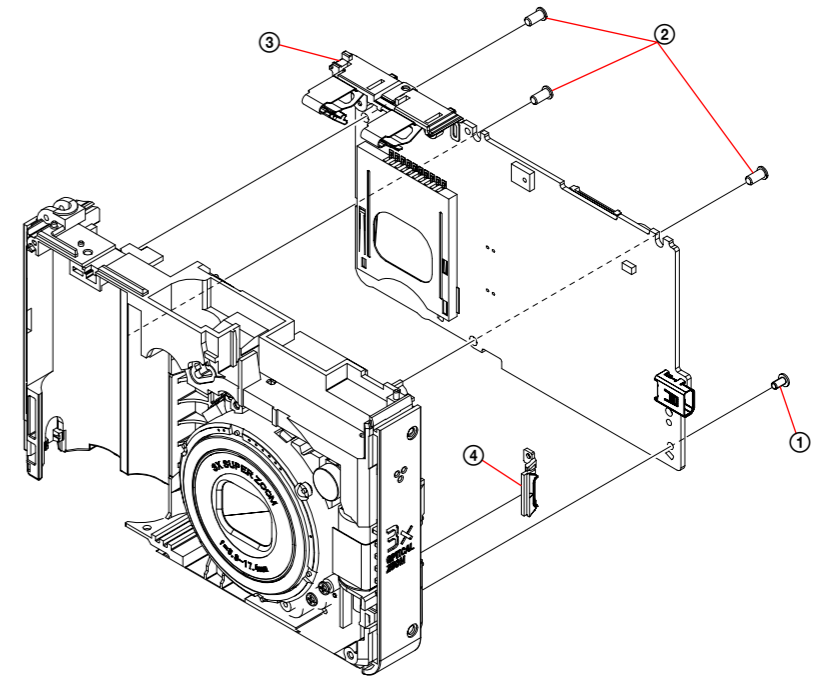

- ① SCREW TP 1.4 X 2.5
- ② SCREW TP 1.7 X 3.5
- ③ MAIN MOUNT
- ④ SUPPORT (JACK)

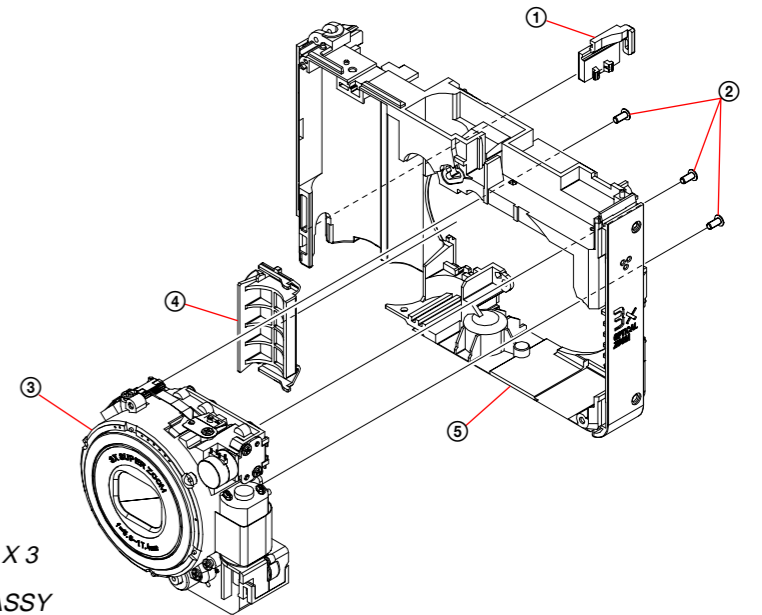

- ① JACK LID
- ② SCREW TP 1.4 X 3
- ③ LENS BLOCK ASSY
- ④ LID
- ⑤ MAIN FRAME

### 3. BLOCK DIAGRAM

#### 3-1. OVERALL BLOCK DIAGRAM

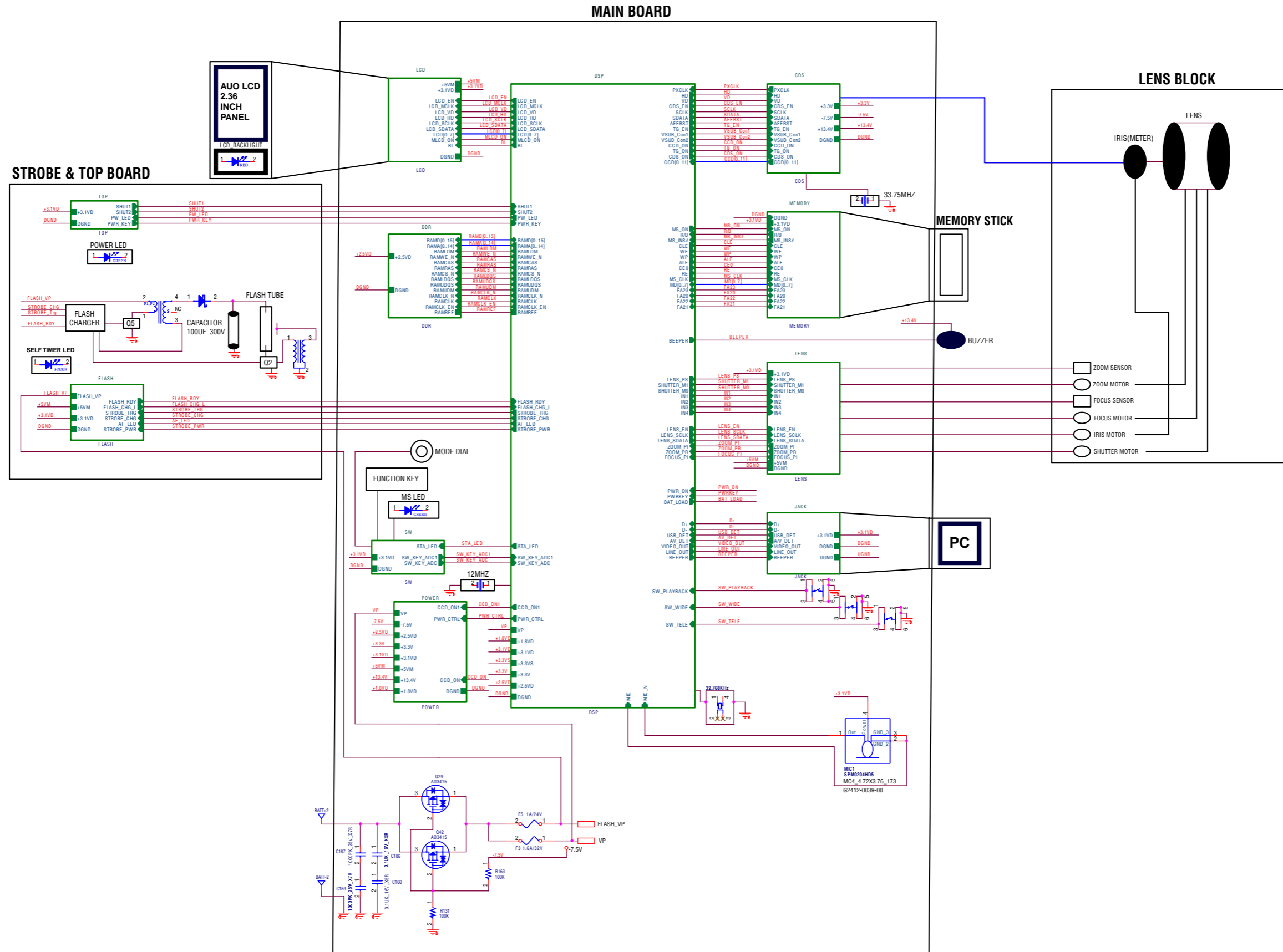

## 4. REPAIR PARTS LIST

### 4-1. EXPLODED VIEWS

#### 4-1-1. OVERALL SECTION

ns: not supplied

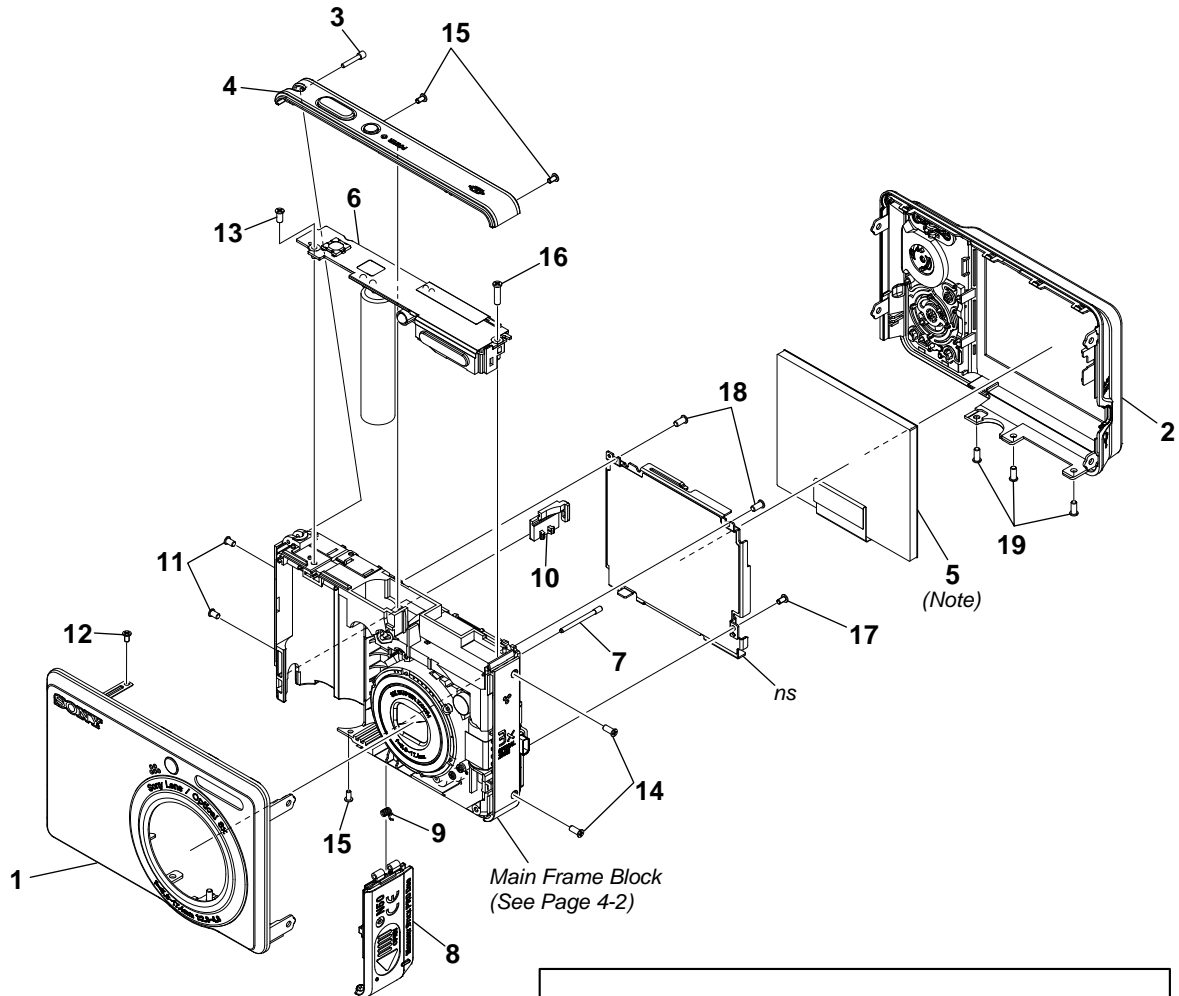

Note : The adjustment is not required after replacing the LCD

- Refer to cover for mark △.

Ref. No.	Part No.	Description	Ref. No.	Part No.	Description
1	X-2188-411-1	CABINET (FRONT) ASSY	11	3-287-023-11	SCREW M1.7 X 2.7
2	X-2188-412-1	CABINET (REAR) ASSY	12	3-287-026-01	SCREW TP1.4 X 2.5
3	3-286-696-01	SHAFT, STRAP	13	3-287-028-01	SCREW TP1.7 X 3.5
4	3-286-697-01	BLOCK, RL	14	3-287-027-01	SCREW TP1.7 X 4
5	3-286-698-01	LCD	15	3-287-025-01	SCREW TP1.4 X 3
△6	A-1444-049-A	ST BLOCK ASSY	16	3-287-032-01	SCREW TP1.7 X 6.5
7	3-286-700-01	SHAFT, BT LID	17	3-296-920-01	SCREW TP1.4 X 3.5
8	3-286-701-01	LID, BT	18	3-296-921-01	SCREW TP1.4 X 4
9	3-286-702-01	SPRING, BT LID	19	3-299-366-01	SCREW TP1.7 X 3.5
10	3-286-703-01	LID, JACK			

## 4. REPAIR PARTS LIST

### 4-1-2. MAIN FRAME BLOCK

ns: not supplied

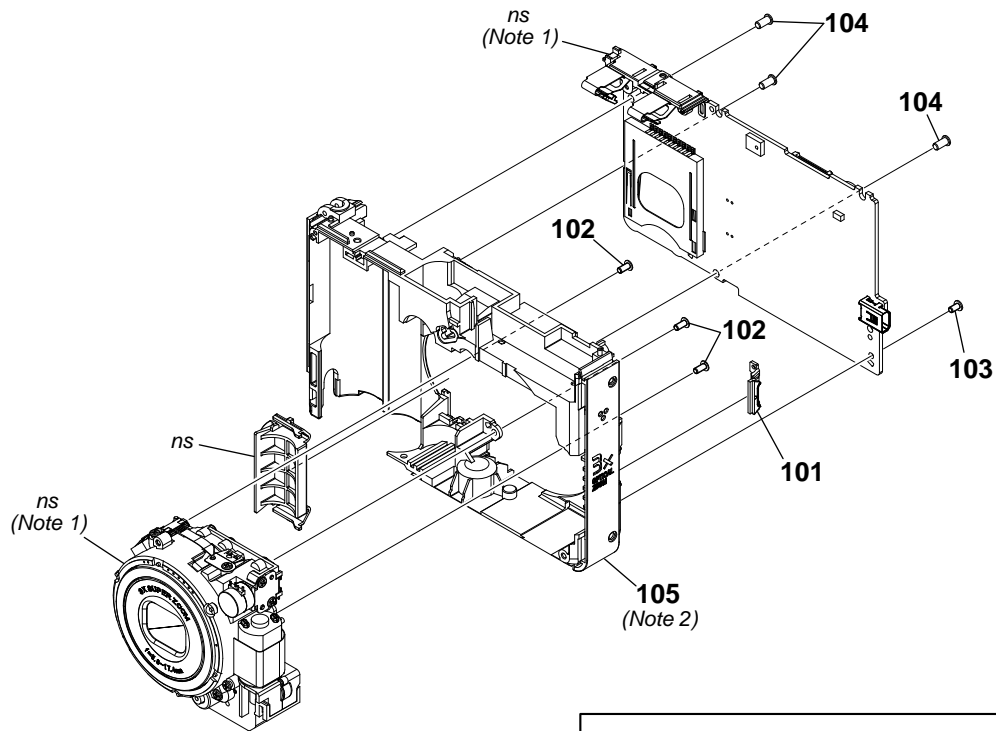

Note 1 : In case of the lens block assy or main board failure, contact your local Sony service Headquarter for the measures.

Note 2 : When separate lens block assy and main board for main frame replacement, assemble original lens block assy and main board back after reparaire.

Ref. No.	Part No.	Description
101	3-286-699-01	SUPPORT (JACK)
102	3-287-024-01	SCREW TP1.4 X 3
103	3-287-026-01	SCREW TP1.4 X 2.5
104	3-287-028-01	SCREW TP1.7 X 3.5
105	3-286-704-01	FRAME, MAIN

## 4. REPAIR PARTS LIST

### 4-2. ACCESSORIES

#### Checking supplied accessories.

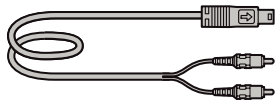

A/V cable  
3-196-980-01

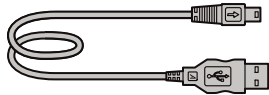

USB cable  
3-196-981-01

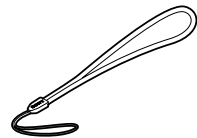

Wrist strap  
2-050-981-01

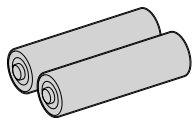

LR6 (size AA) Alkaline Battery  
(Note 1)

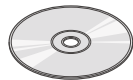

CD-ROM  
(Cyber-shot application software/  
"Cyber-shot Handbook"/  
"Cyber-shot Step-up Guide")  
\*3-281-189-01

Note 1: This item is supplied with the unit as an accessory, but is not prepared as a service part.



Instruction Manual

3-281-198-11	(ENGLISH) (CND, AEP, UK, E, AUS, HK, JE)
3-281-198-21	(FRENCH, ITALIAN) (CND, AEP)
3-281-198-31	(SPANISH, PORTUGUESE) (AEP, E, JE)
3-281-198-41	(GERMAN, DUTCH) (AEP)
3-281-198-51	(TRADITIONAL CHINESE, SIMPLIFIED CHINESE) (E, HK, JE)
3-281-198-61	(RUSSIAN, UKRAINIAN) (AEP)
3-281-198-71	(ARABIC, PERSIAN) (E)
3-281-198-81	(KOREAN) (KR, JE)
3-281-198-91	(POLISH, CZECH) (AEP)
3-281-199-11	(HUNGARIAN, SLOVAK) (AEP)
3-281-199-21	(SWEDISH, FINNISH) (AEP)
3-281-199-31	(NORWEGIAN, DANISH)(AEP)
3-281-199-41	(THAI, MALAYSIAN) (E)
3-281-199-51	(TURKISH, GREEK) (AEP)
3-281-199-61	(ENGLISH, SPANISH) (US)
3-281-199-71	(SIMPLIFIED CHINESE) (CH)



Cyber-shot Handbook(PDF)

The CD-ROM supplied contains all of language version of the Instruction Manual in pdf (Cyber-shot Handbook.pdf) for printing.

- The printed matter is not supplied. If required, please order it with the part number below.

* 3-281-190-11	(ENGLISH)	* 3-281-191-51	(POLISH)
* 3-281-190-21	(FRENCH)	* 3-281-191-61	(CZECH)
* 3-281-190-31	(ITALIAN)	* 3-281-191-71	(HUNGARIAN)
* 3-281-190-41	(SPANISH)	* 3-281-191-81	(SLOVAK)
* 3-281-190-51	(PORTUGUESE)	* 3-281-191-91	(SWEDISH)
* 3-281-190-61	(GERMAN)	* 3-281-192-11	(FINNISH)
* 3-281-190-71	(DUTCH)	* 3-281-192-21	(NORWEGIAN)
* 3-281-190-81	(TRADITIONAL CHINESE)	* 3-281-192-31	(DANISH)
* 3-281-190-91	(SIMPLIFIED CHINESE)	* 3-281-192-41	(THAI)
* 3-281-191-11	(RUSSIAN)	* 3-281-192-51	(MALAYSIAN)
* 3-281-191-21	(ARABIC)	* 3-281-192-61	(TURKISH)
* 3-281-191-31	(PERSIAN)	* 3-281-192-71	(GREEK)
* 3-281-191-41	(KOREAN)	* 3-281-192-81	(UKRAINIAN)

#### NOTE:

- Items marked "\*" are not stocked since they are seldom required for routine service. Some delay should be anticipated when ordering these items.
- Abbreviation  
 AUS : Australian model  
 CH : Chinese model  
 CND : Canadian model  
 HK : Hong Kong model  
 JE : Tourist model  
 KR : Korea model

## 【Regarding Fuse】

•MAIN BOARD

