

DSC-S45

SERVICE MANUAL

US Model

Ver 1.1 2006.05

Revision History

How to use
Acrobat Reader

Internal memory
ON BOARD



Link

• SPECIFICATIONS

• DISASSEMBLY

• REPAIR PARTS LIST

• SERVICE NOTE

• BLOCK DIAGRAMS

The components identified by mark Δ or dotted line with mark Δ are critical for safety. Replace only with part number specified.

Les composants identifiés par une marque Δ sont critiques pour la sécurité. Ne les remplacer que par une pièce portant le numéro spécifié.

In case of the lens, main board, or main frame failure, contact your local Sony Service Headquarter for the measures.

DIGITAL STILL CAMERA

SONY[®]

SPECIFICATIONS

[System]

Image device

7.17 mm (1/2.5 type) color CCD, Primary color filter

Total pixel number of camera

Approx. 5 255 000 pixels

Effective pixel number of camera

Approx. 5 090 000 pixels

Lens

3× zoom lens
f = 5.4 - 16.2 mm (32 - 96 mm when converted to a 35 mm still camera)
F2.8 - 4.8

Exposure control

Automatic exposure, Scene Selection (6 modes)

White balance

Automatic, Daylight, Cloudy, Fluorescent, Incandescent

File format (DCF compliant)

Still images: Exif Ver. 2.2
JPEG compliant, DPOF compatible
Movies: AVI (Motion JPEG)

Recording media

Internal memory (10 MB)
“Memory Stick Duo (with MagicGate/without MagicGate)”
“Memory Stick PRO Duo”
“MagicGate Memory Stick Duo”

Flash

Recommended distance (ISO set to Auto):
Approx. 0.5 m to 2.5 m
(19 3/4 inches to 98 1/2 inches) (W)/
Approx. 0.5 m to 2.0 m
(19 3/4 inches to 78 3/4 inches) (T)

[Input and Output connectors]

A/V OUT jack

Mini-jack
Video signal : 1 V_{p-p}, 75 Ω (ohms), unbalanced, sync negative
Audio signal : 2 V (at load impedance more than 47 k Ω (kilohms))
Output impedance with less than 2.2 k Ω (kilohms)

USB jack

mini-B

USB communication

Full-Speed USB (USB 2.0 compliant)

[LCD screen]

LCD panel

6.2 cm (2.4 type) TFT drive

Total number of dots

110 000 (480 × 234) dots

[Power, general]

Power

LR6 (size AA) Alkaline batteries (2), 3 V
HR15/51:HR6 (Size AA) Nickel-Metal Hydride batteries (not supplied) (2), 2.4 V
ZR6 (size AA) Oxy Nickel Primary Battery (2) (not supplied), 3 V
AC-LS5K AC Adaptor (not supplied), 4.2V

Power consumption

(during shooting with the LCD screen on)

1.65 W

Operating temperature

0 to 40°C (32 to 104°F)

Storage temperature

-20 to +60°C (-4 to +140°F)

Dimensions

92 × 62 × 31 mm
(3 3/4 × 2 1/2 × 1 1/4 inches)
(W/H/D, excluding protrusions)

Mass

Approx. 198 g (7.0 oz) (including two batteries and wrist strap, etc.)

Microphone

Electret condenser microphone

Buzzer

Piezo-electric buzzer

Exif Print

Compatible

PRINT Image Matching III

Compatible

PictBridge

Compatible

Design and specification are subject to change without notice.

CAUTION

Danger of explosion if battery is incorrectly replaced.
Replace only with the same or equivalent type.

SAFETY-RELATED COMPONENT WARNING!!

COMPONENTS IDENTIFIED BY MARK \triangle OR DOTTED LINE WITH MARK \triangle ON THE SCHEMATIC DIAGRAMS AND IN THE PARTS LIST ARE CRITICAL TO SAFE OPERATION. REPLACE THESE COMPONENTS WITH SONY PARTS WHOSE PART NUMBERS APPEAR AS SHOWN IN THIS MANUAL OR IN SUPPLEMENTS PUBLISHED BY SONY.

ATTENTION AU COMPOSANT AYANT RAPPORT À LA SÉCURITÉ!

LES COMPOSANTS IDENTIFIÉS PAR UNE MARQUE \triangle SUR LES DIAGRAMMES SCHÉMATIQUES ET LA LISTE DES PIÈCES SONT CRITIQUES POUR LA SÉCURITÉ DE FONCTIONNEMENT. NE REMPLACER CES COMPOSANTS QUE PAR DES PIÈCES SONY DONT LES NUMÉROS SONT DONNÉS DANS CE MANUEL OU DANS LES SUPPLÉMENTS PUBLIÉS PAR SONY.

SAFETY CHECK-OUT

After correcting the original service problem, perform the following safety checks before releasing the set to the customer.

1. Check the area of your repair for unsoldered or poorly-soldered connections. Check the entire board surface for solder splashes and bridges.
2. Check the interboard wiring to ensure that no wires are "pinched" or contact high-wattage resistors.
3. Look for unauthorized replacement parts, particularly transistors, that were installed during a previous repair. Point them out to the customer and recommend their replacement.
4. Look for parts which, through functioning, show obvious signs of deterioration. Point them out to the customer and recommend their replacement.
5. Check the B+ voltage to see it is at the values specified.
6. FLEXIBLE Circuit Board Repairing
 - Keep the temperature of the soldering iron around 270°C during repairing.
 - Do not touch the soldering iron on the same conductor of the circuit board (within 3 times).
 - Be careful not to apply force on the conductor when soldering or unsoldering.

Unleaded solder

Boards requiring use of unleaded solder are printed with the lead-free mark (LF) indicating the solder contains no lead. (Caution: Some printed circuit boards may not come printed with the lead free mark due to their particular size.)



: LEAD FREE MARK

Unleaded solder has the following characteristics.

- Unleaded solder melts at a temperature about 40°C higher than ordinary solder.
Ordinary soldering irons can be used but the iron tip has to be applied to the solder joint for a slightly longer time.
Soldering irons using a temperature regulator should be set to about 350°C.
Caution: The printed pattern (copper foil) may peel away if the heated tip is applied for too long, so be careful!
- Strong viscosity
Unleaded solder is more viscous (sticky, less prone to flow) than ordinary solder so use caution not to let solder bridges occur such as on IC pins, etc.
- Usable with ordinary solder
It is best to use only unleaded solder but unleaded solder may also be added to ordinary solder.

TABLE OF CONTENTS

<i>Section</i>	<i>Title</i>	<i>Page</i>
1. SERVICE NOTE		
1-1.	Process After Fixing Flash Error	1-1
1-2.	Method for Copying or Erasing the Data in Internal Memory	1-1
2. DISASSEMBLY		
2-1.	Disassembly	2-1
3. BLOCK DIAGRAMS		
3-1.	Overall Block Diagram	3-1
3-2.	Power Block Diagram	3-2
4. REPAIR PARTS LIST		
4-1.	Exploded Views	4-1
4-1-1.	Overall Section	4-1
4-1-2.	Front Block	4-2
4-1-3.	Main Frame Block	4-3
4-2.	Accessories	4-4

1. SERVICE NOTE

1-1. PROCESS AFTER FIXING FLASH ERROR

Method for Initializing the Flash Error

Initialize

Initializes the setting to the default setting.

	OK	See the following procedure.
✓	Cancel	Cancels the resetting.

- ① Select [OK] with ▲ on the control button, then press ●.
The message "Initialize all settings Ready?" appears.
 - ② Select [OK] with ▲, then press ●.
The settings are reset to the default setting.
- Make sure that the power is not disconnected during resetting.

1-2. METHOD FOR COPYING OR ERASING THE DATA IN INTERNAL MEMORY

The data can be copied/erased by the operations on the Setup screen. (When erasing the data, execute formatting the internal memory.)

Note: When replacing the camera, erase the data in internal memory of the board before replacement.

Method for Copying the Data in Internal Memory

Copy

Copies all images in the internal memory to a "Memory Stick Duo".

	OK	See the following procedure.
✓	Cancel	Cancels the copying.

- ① Insert a "Memory Stick Duo" having 16 MB or larger capacity.
- ② Select [OK] with ▲ on the control button, then press ●.
The message "All data in internal memory will be copied Ready?" appears.
- ③ Select [OK] with v, then press ●.
Copying starts.

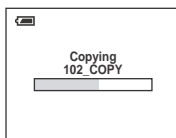

- Use batteries with enough capacity or the AC Adaptor (not supplied). If you attempt to copy image files using batteries with little remaining charge, the batteries may run out, causing copying to fail or possibly corrupting the data.
- You cannot copy individual images.
- The original images in the internal memory are retained even after copying. To delete the contents of the internal memory, remove the "Memory Stick Duo" after copying, then execute the [Format] command in Internal Memory Tool.
- You cannot select a folder copied on a "Memory Stick Duo".
- The setting of  (Print order)marks is not copied even when you copy data.

Method for Formatting the Internal Memory

This item does not appear when a "Memory Stick Duo" is inserted in the camera.
The default settings are marked with ✓.

Format

Formats the internal memory.

- Note that formatting irrevocably erases all data in the internal memory, including even protected images.

	OK	See the following procedure.
✓	Cancel	Cancels the formatting.

- ① Select [OK] with ▲ on the control button, then press ●.
The message "All data in internal memory will be erased Ready?" appears.
- ② Select [OK] with ▲, then press ●.
The format is complete.

2. DISASSEMBLY

The following flow chart shows the disassembly procedure.

2-1. DISASSEMBLY

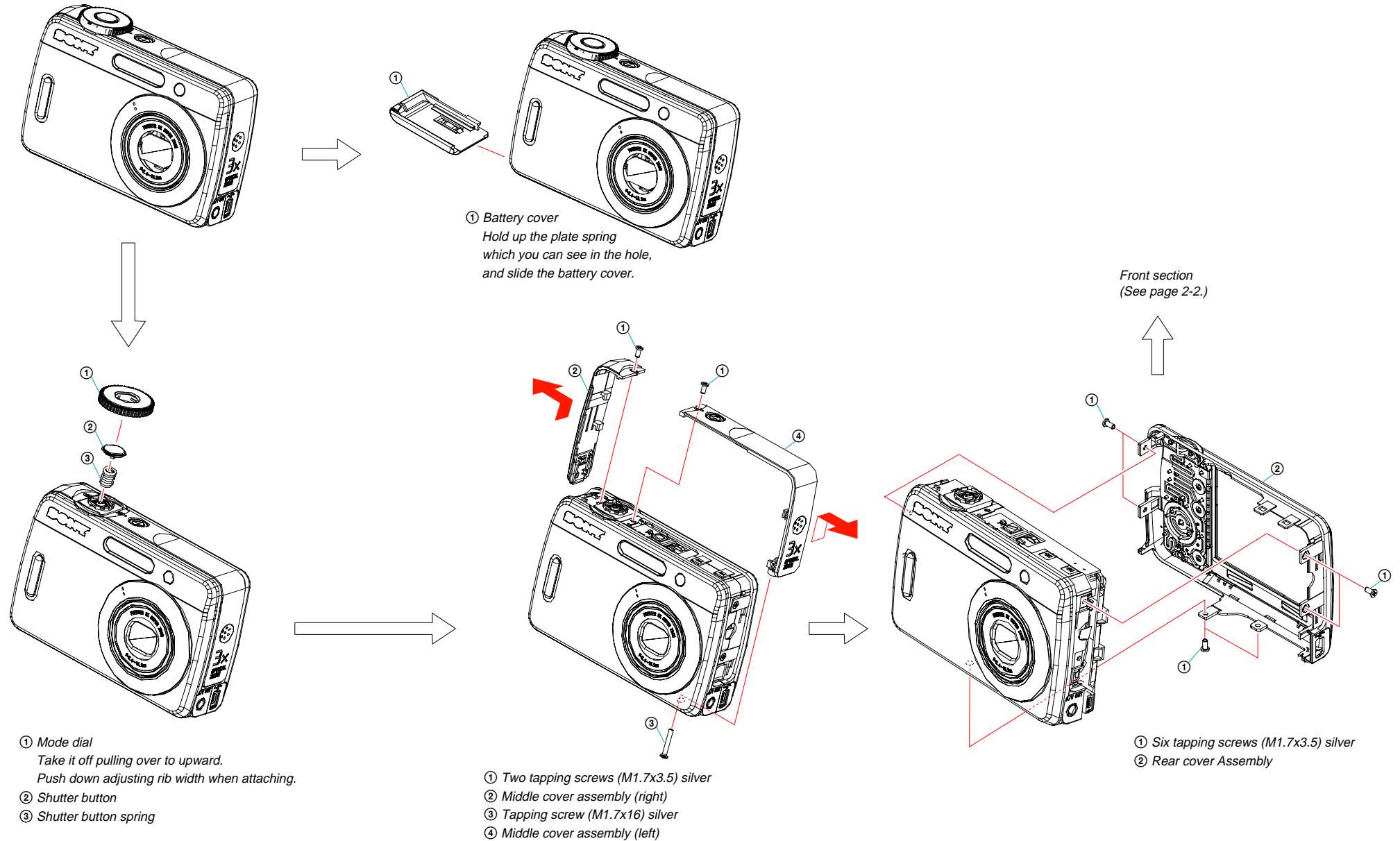

2. DISASSEMBLY

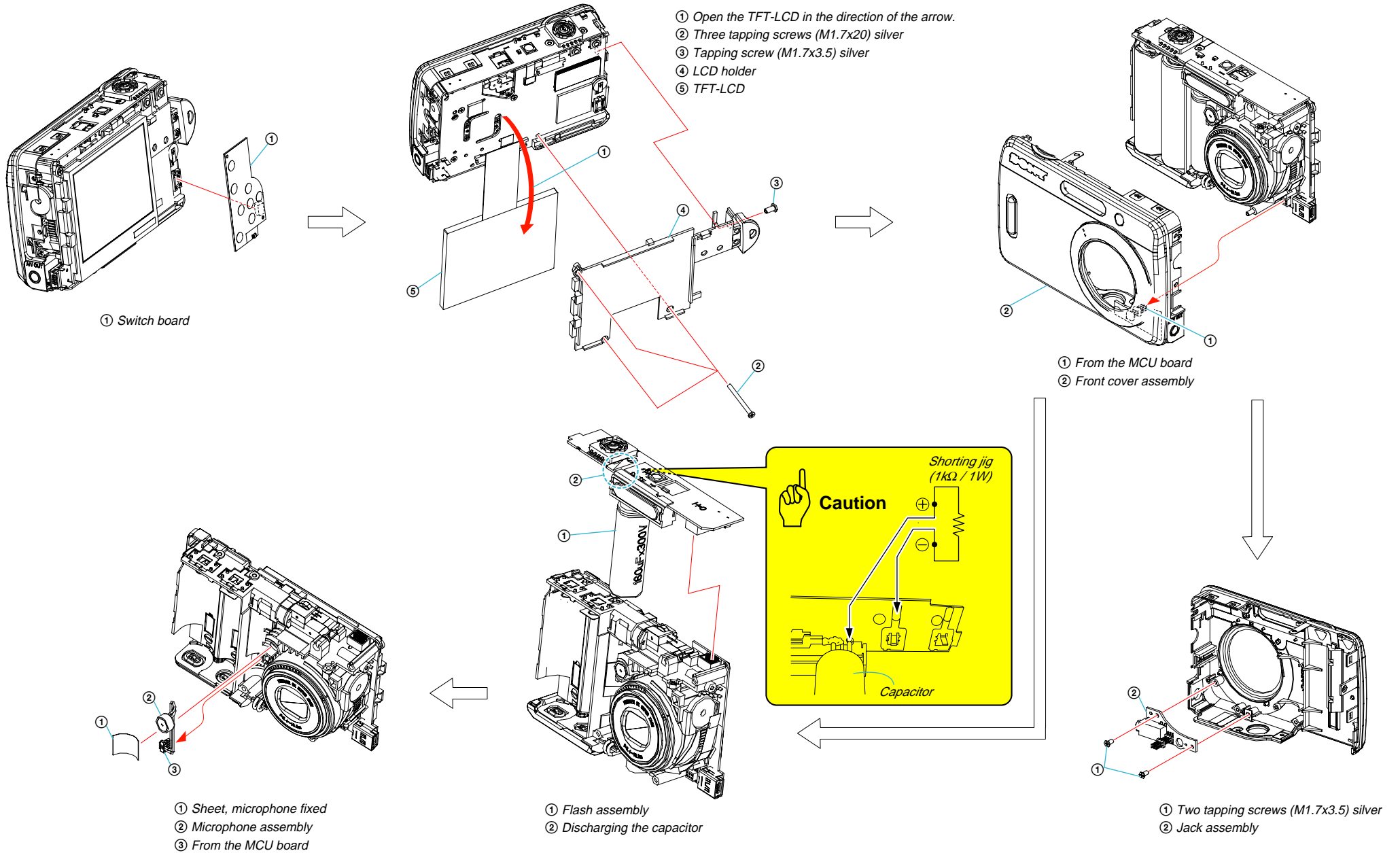

3. BLOCK DIAGRAMS

3-1. OVERALL BLOCK DIAGRAM

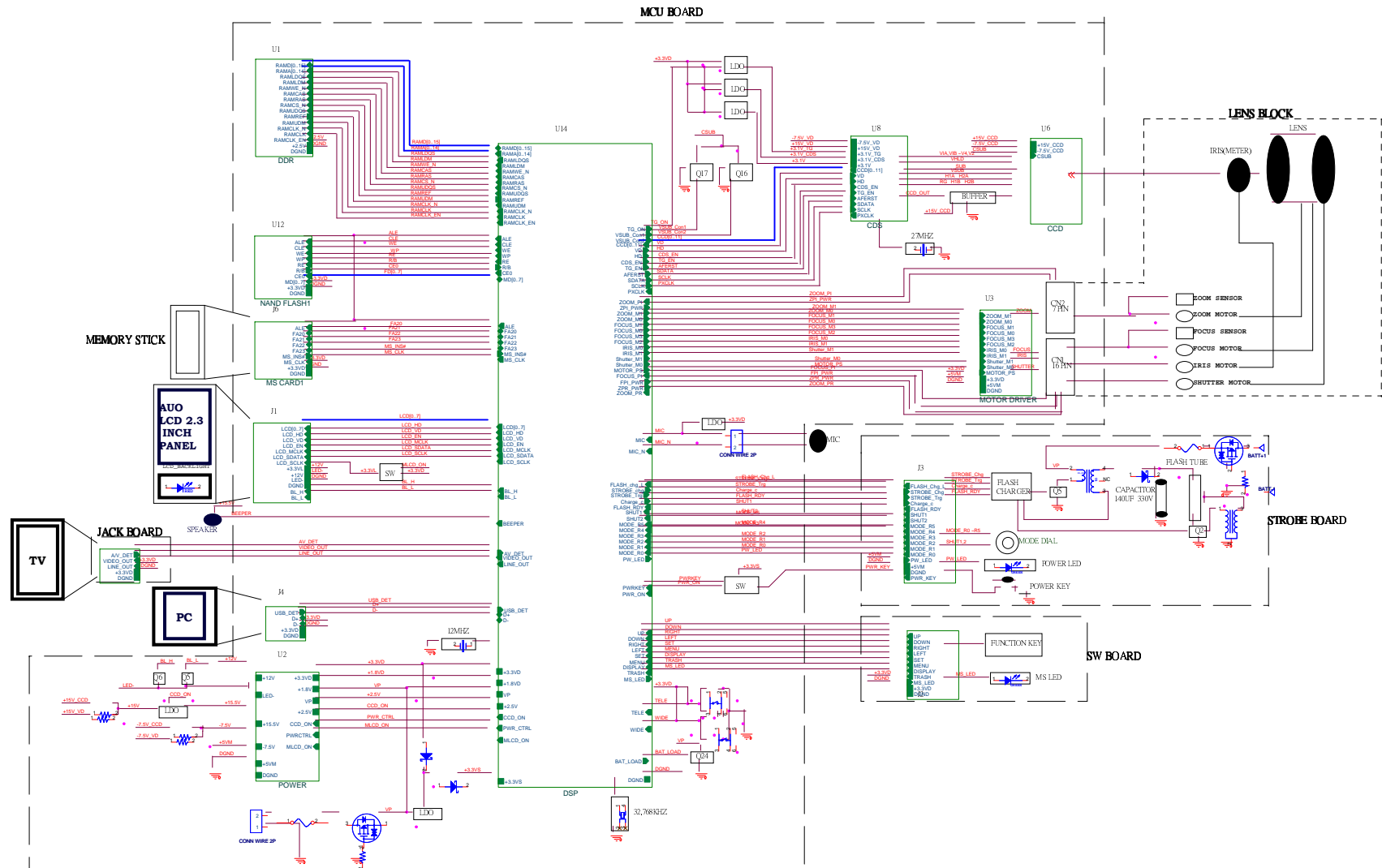

4. REPAIR PARTS LIST

4-1. EXPLODED VIEWS

4-1-1. OVERALL SECTION

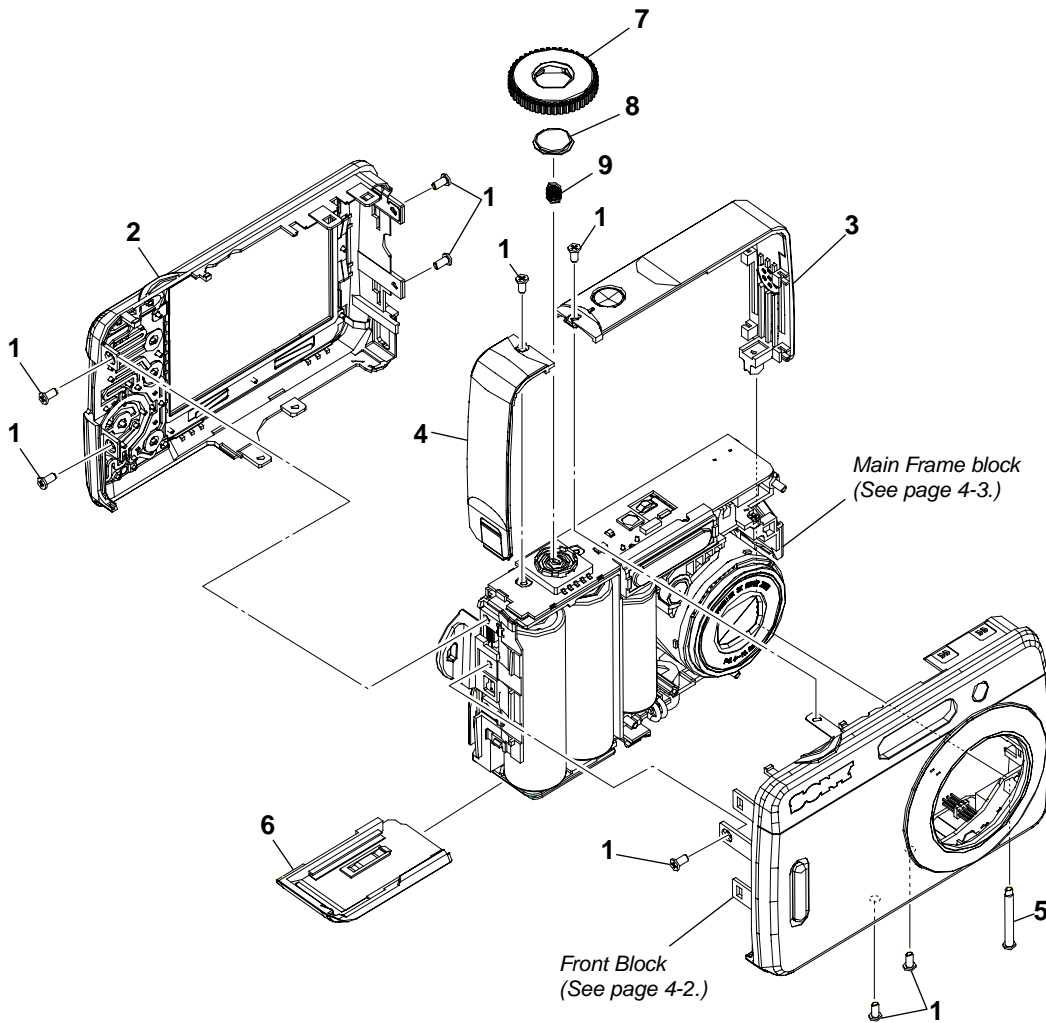

Ref. No.	Part No.	Description
1	2-682-984-01	Screw TP1.7*3.5
2	X-2109-749-1	Rear Cover Assy
3	X-2109-764-1	Middle Cover Assy (left)
4	X-2109-765-1	Middle Cover Assy (right)
5	2-694-421-01	Screw TP1.7*16

Ref. No.	Part No.	Description
6	2-682-971-01	Battery Cover
7	2-682-974-01	Mode Dial
8	2-682-975-01	Shutter Button
9	2-682-976-01	Shutter Button Spring

4. REPAIR PARTS LIST

4-1-2. FRONT BLOCK

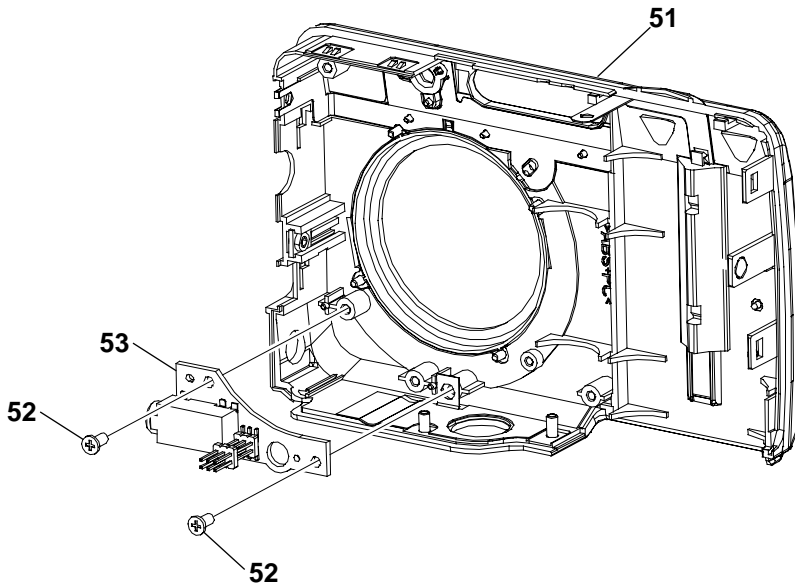

<u>Ref. No.</u>	<u>Part No.</u>	<u>Description</u>
51	X-2109-748-1	Front Cover Assy
52	2-682-984-01	Screw TP1.7*3.5
53	A-1188-384-A	Jack Assy

4. REPAIR PARTS LIST

4-1-3. MAIN FRAME BLOCK

ns: not supplied

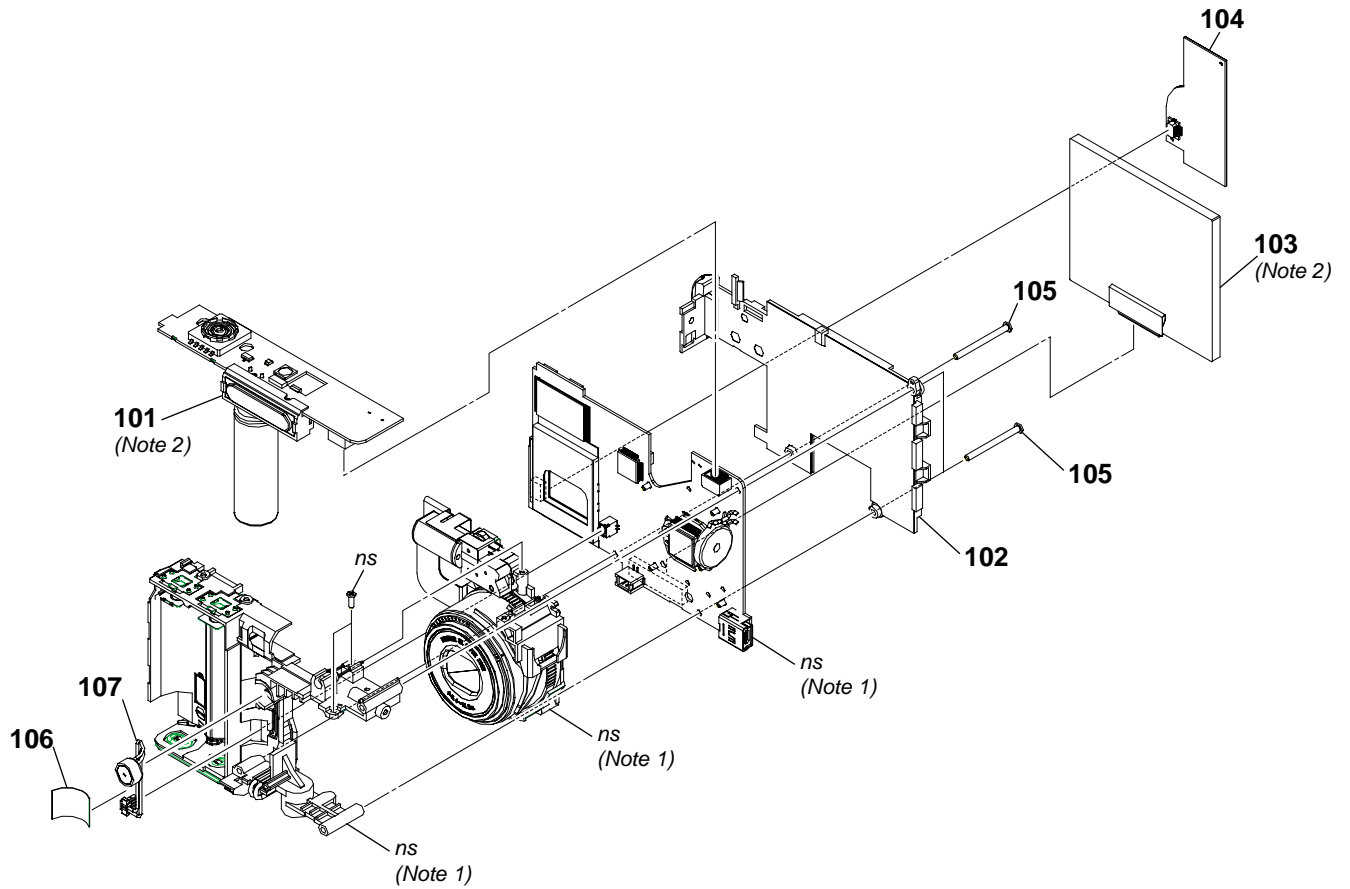

(Note 1) In case of the lens, main board, or main frame failure, contact your local Sony Service Headquarter for the measures.

(Note 2) The adjustment is not required after replacing the flash assy or LCD.

Ref. No.	Part No.	Description
101	A-1188-387-A	Flash Assy (Note 2)
102	2-682-972-01	LCD Holder
103	A-1188-385-A	TFT-LCD (Note 2)
104	A-1188-386-A	Switch Board

Ref. No.	Part No.	Description
105	2-682-983-01	Screw TP1.7*20
106	2-682-993-01	Sheet, Microphone Fixed
107	A-1188-556-A	Microphone Assy

4. REPAIR PARTS LIST

4-2. ACCESSORIES

Checking supplied accessories.

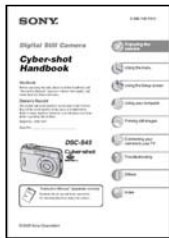
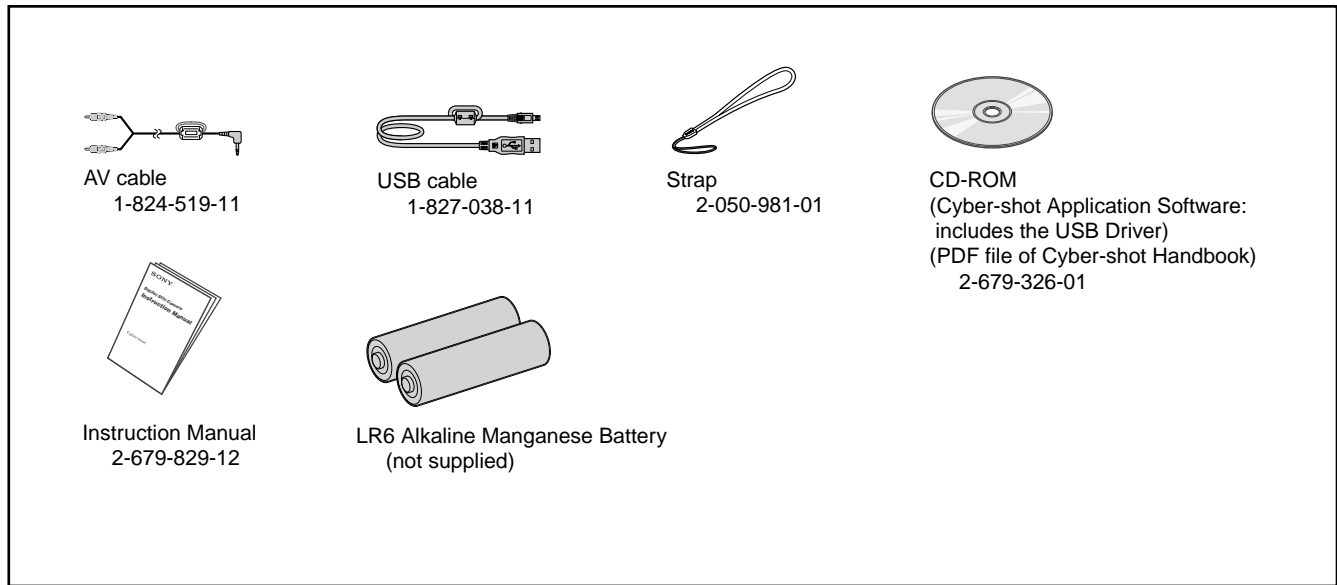

Cyber-shot Handbook
(not supplied with DSC-S45)
2-680-136-11

[Description of main button functions on toolbar of the Adobe Acrobat Reader Ver5.0 (for Windows)]

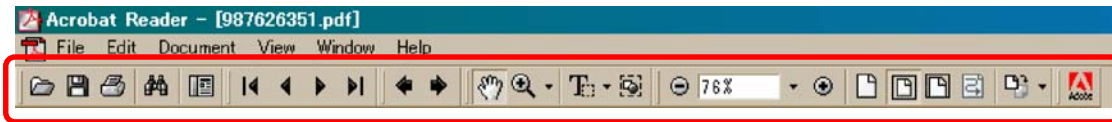

Toolbar



Printing a text

1. Click the Print button .
2. Specify a printer, print range, number of copies, and other options, and then click [OK].

Application of printing:

To set a range to be printed within a page, select the graphic selection tool  and drag on the page to enclose a range to be printed, and then click the Print button.

Reversing the screens displayed once

- To reverse the previous screens (operation) one by one, click the .
- To advance the reversed screens (operation) one by one, click the .

Application to the Service Manual:

This function allows you to go and back between circuit diagram and printed circuit board diagram, and accordingly it will be convenient for the voltage check.

Finding a text

1. Click the Find button .
2. Enter a character string to be found into a text box, and click the [Find]. (Specify the find options as necessary)

Application to the Service Manual:

To execute “find” from current page toward the previous pages, select the check box “Find Backward” and then click the “Find”.

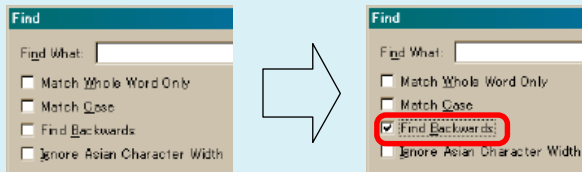





3. Open the find dialog box again, and click the [Find Again] and you can find the matched character strings displayed next. (Character strings entered previously are displayed as they are in the text box.)

Application to the Service Manual:

The parts on the drawing pages (block diagrams, circuit diagrams, printed circuit boards) and parts list pages in a text can be found using this find function. For example, find a Ref. No. of IC on the block diagram, and click the [Find Again] continuously, so that you can move to the Ref. No. of IC on the circuit diagram or printed circuit board diagram successively.

Note: The find function may not be applied to the Service Manual depending on the date of issue.

Moving with link

1. Select either palm tool , zoom tool , text selection tool , or graphic selection tool .
2. Place the pointer in the position in a text where the link exists (such as a button on cover and the table of contents page, or blue characters on the removal flowchart page or drawing page), and the pointer will change to the forefinger form .
3. Then, click the link. (You will go to the link destination.)

Moving with bookmark:

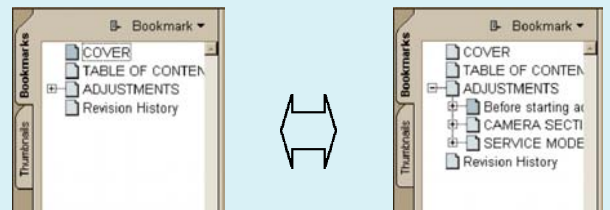

Click an item (text) on the bookmark pallet. and you can move to the link destination. Also, clicking  can display the hidden items.

(To go back to original state, click )



Zooming or rotating the screen display

“Zoom in/out”

- Click the triangle button in the zoom control box to select the display magnification. Or, you may click  or  for zooming in or out.

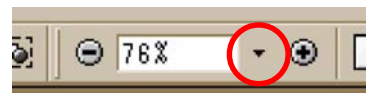





“Rotate”

- Click rotate tool , and the page then rotates 90 degrees each.

Application to the Service Manual:

The printed circuit board diagram you see now can be changed to the same direction as the set.

Switching a page

- To move to the first page, click the .
- To move to the last page, click the .
- To move to the previous page, click the .
- To move to the next page, click the .

