

DSC-P93

SERVICE MANUAL

LEVEL 2

Ver 1.1 2004.10

Revision History

How to use
Acrobat Reader



US Model
Canadian Model
AEP Model
UK Model
E Model
Hong Kong Model
Australian Model
Chinese Model
Korea Model
Argentine Model
Brazilian Model
Tourist Model

Link

SPECIFICATIONS	BLOCK DIAGRAMS	PRINTED WIRING BOARDS
SERVICE NOTE	FRAME SCHEMATIC DIAGRAM	REPAIR PARTS LIST
DISASSEMBLY	SCHEMATIC DIAGRAMS	

- For ADJUSTMENTS (SECTION 6), refer to SERVICE MANUAL, ADJ (987672551.pdf).
- For INSTRUCTION MANUAL, refer to SERVICE MANUAL, LEVEL 1 (987672541.pdf).
- **Reference No. search on printed wiring boards is available.**
- [Note in Lens Frame Installation](#)
- [HELP: Sheet attachment positions and procedures of processing the flexible boards/harnesses are shown.](#)

On the CH-146 and SY-100 boards

This service manual provides the information that is premised the circuit board replacement service and not intended repair inside the CH-146 and SY-100 boards.

Therefore, schematic diagram, printed wiring board and electrical parts list of the CH-146 and SY-100 boards are not shown.

The following pages are not shown.

Schematic diagram Pages 4-9 to 4-26
Printed wiring board Pages 4-39 to 4-42
Mounted parts location Pages 4-50
Electrical parts list Pages 5-7 and 5-10 to 5-13

The above-described information is shown in service manual Level 3.

DIGITAL STILL CAMERA

SONY®



Cyber-shot



SPECIFICATIONS

■ Camera

[System]

Image device	9.04 mm (1/1.8 type) color CCD Primary color filter
Total pixels number of camera	Approx. 5 255 000 pixels
Effective pixels number of camera	Approx. 5 090 000 pixels
Lens	3× zoom lens f=7.9 to 23.7 mm (35 mm camera conversion: 38 to 114 mm) F2.8-5.2
Exposure control	Automatic, Manual exposure, Twilight, Twilight portrait, Candle, Landscape, Beach, Soft snap
White balance	Automatic, Daylight, Cloudy, Fluorescent, Incandescent
File format (DCF compliant)	Still images: Exif Ver. 2.2, JPEG compliant, DPOF compatible Movies: MPEG1 compliant (Monaural)
Recording medium	"Memory Stick"
Flash	Recommended distance (when ISO sensitivity is set to Auto) 0.2 to 3.5 m (7 ⁷ / ₈ inches to 11 feet 5 ⁷ / ₈ inches) (W) 0.6 to 2.5 m (23 ⁵ / ₈ inches to 8 feet 2 ¹ / ₂ inches) (T)

[Output connectors]

A/V OUT (MONO) jack (Monaural)	Minijack Video: 1 V _{p-p} , 75 Ω, unbalanced, sync negative Audio: 327 mV (at a 47 kΩ load) Output impedance 2.2 kΩ
USB jack	mini-B
USB communication	Hi-Speed USB (USB 2.0 compliant)

[LCD screen]

LCD panel used	3.8 cm (1.5 type) TFT drive
Total number of dots	134 400 (560×240) dots

[Power, general]

Power	AA nickel hydride batteries (2) 2.4 V AC-LS5 AC Adaptor (not supplied), 4.2 V
Power consumption (during shooting with LCD screen on)	1.2 W
Operating temperature range	0° to +40°C (32° to +104°F)
Storage temperature range	-20° to +60°C (-4° to +140°F)
Dimensions	117.2 × 53.7 × 35.8 mm (4 ⁵ / ₈ × 2 ¹ / ₈ × 1 ⁷ / ₁₆ inches) (W/H/D, protruding portions not included)
Mass	Approx. 236 g (0.5 lb 8.3 oz) (two batteries, "Memory Stick," wrist strap, and so on included)
Microphone	Electret condenser microphone
Speaker	Dynamic speaker
Exif Print	Compatible
PRINT Image	Matching II Compatible
PictBridge	Compatible

■ BC-CS2A/CS2B Ni-MH battery charger

Power requirements	AC 100 to 240V 50/60Hz 3 W
Output voltage	AA : DC 1.4 V 400 mA × 2 AAA : DC 1.4 V 160 mA × 2
Operating temperature range	0° to +40°C (32° to +104°F)
Storage temperature range	-20° to +60°C (-4° to +140°F)
Dimensions	71 × 30 × 91 mm (2 ⁷ / ₈ × 1 ³ / ₁₆ × 3 ⁵ / ₈ inches) (W/H/D)
Mass	Approx. 90 g (3 oz)

■ AC-LS5 AC Adaptor (not supplied)

Input rating	AC 100 to 240 V, 50/60 Hz 11 W, 0.16 to 0.09 A
Output rating	DC 4.2 V, 1.5 A
Operating temperature range	0° to +40°C (32° to +104°F)
Storage temperature range	-20° to +60°C (-4° to +140°F)
Maximum dimensions	Approx. 48 × 29 × 81 mm (1 ¹⁵ / ₁₆ × 1 ³ / ₁₆ × 3 ¹ / ₄ inches) (W/H/D)
Mass	Approx. 130 g (5 oz)

Accessories

- HR6 (size AA) Ni-MH batteries (2)
 - Battery case (1)
 - BC-CS2A/CS2B Ni-MH Battery charger (1)
 - Power cord (mains lead) (1)
 - USB cable (1)
 - A/V connecting cable (1)
 - Wrist strap (1)
 - "Memory Stick" (32MB) (1)
 - CD-ROM (USB driver: SPVD-012) (1)
 - Operating Instructions (1)
- See page 5-14.

Design and specifications are subject to change without notice.

SAFETY-RELATED COMPONENT WARNING!!

COMPONENTS IDENTIFIED BY MARK \triangle OR DOTTED LINE WITH MARK \triangle ON THE SCHEMATIC DIAGRAMS AND IN THE PARTS LIST ARE CRITICAL TO SAFE OPERATION. REPLACE THESE COMPONENTS WITH SONY PARTS WHOSE PART NUMBERS APPEAR AS SHOWN IN THIS MANUAL OR IN SUPPLEMENTS PUBLISHED BY SONY.

ATTENTION AU COMPOSANT AYANT RAPPORT À LA SÉCURITÉ!

LES COMPOSANTS IDENTIFIÉS PAR UNE MARQUE \triangle SUR LES DIAGRAMMES SCHÉMATIQUES ET LA LISTE DES PIÈCES SONT CRITIQUES POUR LA SÉCURITÉ DE FONCTIONNEMENT. NE REMPLACER CES COMPOSANTS QUE PAR DES PIÈCES SONY DONT LES NUMÉROS SONT DONNÉS DANS CE MANUEL OU DANS LES SUPPLÉMENTS PUBLIÉS PAR SONY.

SAFETY CHECK-OUT

After correcting the original service problem, perform the following safety checks before releasing the set to the customer.

1. Check the area of your repair for unsoldered or poorly-soldered connections. Check the entire board surface for solder splashes and bridges.
2. Check the interboard wiring to ensure that no wires are "pinched" or contact high-wattage resistors.
3. Look for unauthorized replacement parts, particularly transistors, that were installed during a previous repair. Point them out to the customer and recommend their replacement.
4. Look for parts which, through functioning, show obvious signs of deterioration. Point them out to the customer and recommend their replacement.
5. Check the B+ voltage to see it is at the values specified.
6. Flexible Circuit Board Repairing
 - Keep the temperature of the soldering iron around 270°C during repairing.
 - Do not touch the soldering iron on the same conductor of the circuit board (within 3 times).
 - Be careful not to apply force on the conductor when soldering or unsoldering.

Unleaded solder

Boards requiring use of unleaded solder are printed with the lead-free mark (LF) indicating the solder contains no lead. (Caution: Some printed circuit boards may not come printed with the lead free mark due to their particular size.)

**: LEAD FREE MARK**

Unleaded solder has the following characteristics.

- Unleaded solder melts at a temperature about 40°C higher than ordinary solder. Ordinary soldering irons can be used but the iron tip has to be applied to the solder joint for a slightly longer time. Soldering irons using a temperature regulator should be set to about 350°C. Caution: The printed pattern (copper foil) may peel away if the heated tip is applied for too long, so be careful!
- Strong viscosity. Unleaded solder is more viscous (sticky, less prone to flow) than ordinary solder so use caution not to let solder bridges occur such as on IC pins, etc.
- Usable with ordinary solder. It is best to use only unleaded solder but unleaded solder may also be added to ordinary solder.

TABLE OF CONTENTS

<u>Section</u>	<u>Title</u>	<u>Page</u>
1.	SERVICE NOTE	
1-1.	Note for Repair	1-1
1-2.	Discharging of the ST-095 Board's Charging Capacitor (C852)	1-1
1-3.	Note in Lens Frame Installation	1-2
1-4.	Description on Self-diagnosis Display	1-2
2.	DISASSEMBLY	
2-1.	Flow Chart	2-1
2-2.	SY-100 Board Service Position	2-3
2-3.	Circuit Boards Location	2-5
2-4.	Flexible Boards Location	2-5
3.	BLOCK DIAGRAMS	
3-1.	Overall Block Diagram (1/2)	3-1
3-2.	Overall Block Diagram (2/2)	3-3
3-3.	Power Block Diagram (1/2)	3-5
3-4.	Power Block Diagram (2/2)	3-7
4.	PRINTED WIRING BOARDS AND SCHEMATIC DIAGRAMS	
4-1.	Frame Schematic Diagram	4-1
4-2.	Schematic Diagrams	4-5
	CD-498 (CCD IMAGER)	4-7
	SW-417 (CONTROL SWITCH, LCD DRIVE)	4-27
	ST-095 (FLASH DRIVE)	4-29
	MS (FP-861 FLEXIBLE) (MEMORY STICK CONNECTOR)	4-31
	FP-860 FLEXIBLE (JACK)	4-32
	MIC UNIT (MA-002)	4-33
	CONTROL SWITCH BLOCK (RL530TT)	4-34
4-3.	Printed Wiring Boards	4-35
	CD-498	4-37
	SW-417	4-43
	ST-095	4-45
	MS (FP-861 FLEXIBLE)	4-47
	FP-860 FLEXIBLE	4-48
4-4.	Mounted Parts Location	4-49
5.	REPAIR PARTS LIST	
5-1.	Exploded Views	5-2
5-1-1.	Front Cabinet Block Section	5-2
5-1-2.	Lens Block Section	5-3
5-1-3.	BT Holder Block Section	5-4
5-1-4.	Rear Cabinet Block Section	5-5
5-2.	Electrical Parts List	5-6

SECTION 1 SERVICE NOTE

1-1. NOTE FOR REPAIR

Make sure that the flat cable and flexible board are not cracked or bent at the terminal.
Do not insert the cable insufficiently nor crookedly.

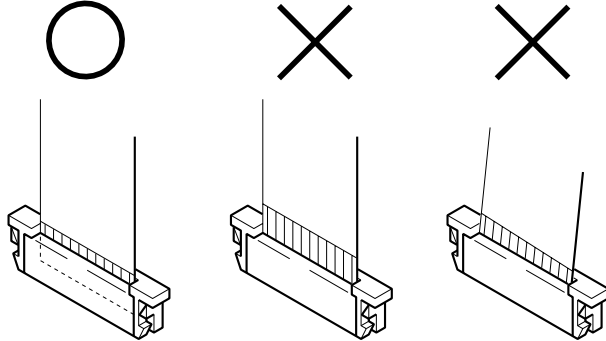

Cut and remove the part of gilt which comes off at the point.
(Be careful or some pieces of gilt may be left inside)

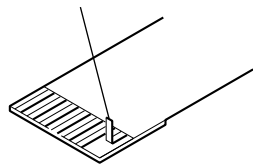

When remove a connector, don't pull at wire of connector.
It is possible that a wire is snapped.

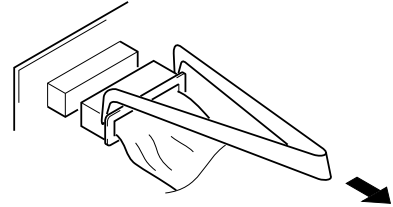

When installing a connector, don't press down at wire of connector.
It is possible that a wire is snapped.

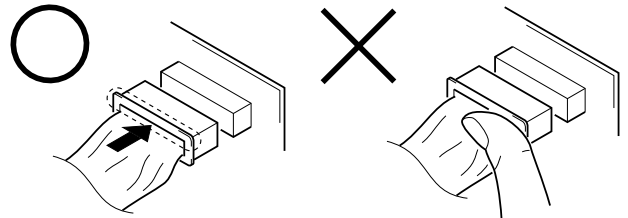

1-2. DISCHARGING OF THE ST-095 BOARD'S CHARGING CAPACITOR (C852)

The charging capacitor (C852) of the ST-095 board is charged up to the maximum 300 V potential.

There is a danger of electric shock by this high voltage when the capacitor is handled by hand. The electric shock is caused by the charged voltage which is kept without discharging when the main power of the unit is simply turned off. Therefore, the remaining voltage must be discharged as described below.

Preparing the Short Jig

To preparing the short jig, a small clip is attached to each end of a resistor of 1 k Ω / 1 W (1-215-869-11).
Wrap insulating tape fully around the leads of the resistor to prevent electrical shock.

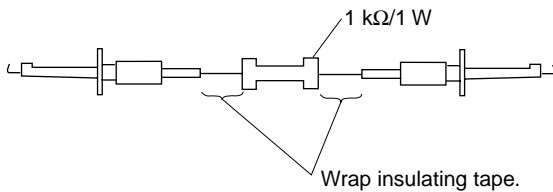

Discharging the Capacitor

Short-circuit between the positive and the negative terminals of charged capacitor with the short jig about 10 seconds.

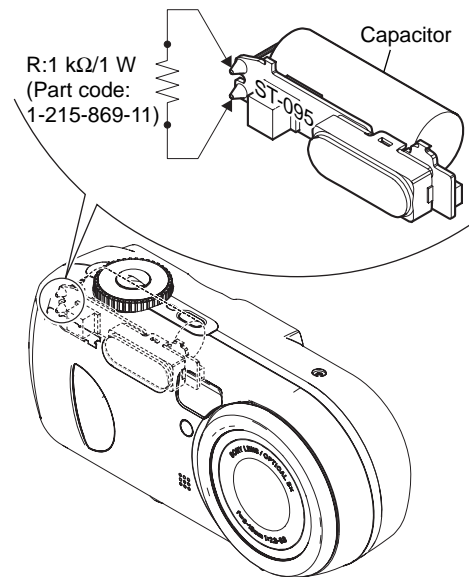

1-3. NOTE IN LENS FRAME INSTALLATION

When tightening a screw, have both sides of the lens block assembly so as not for the load to depend.

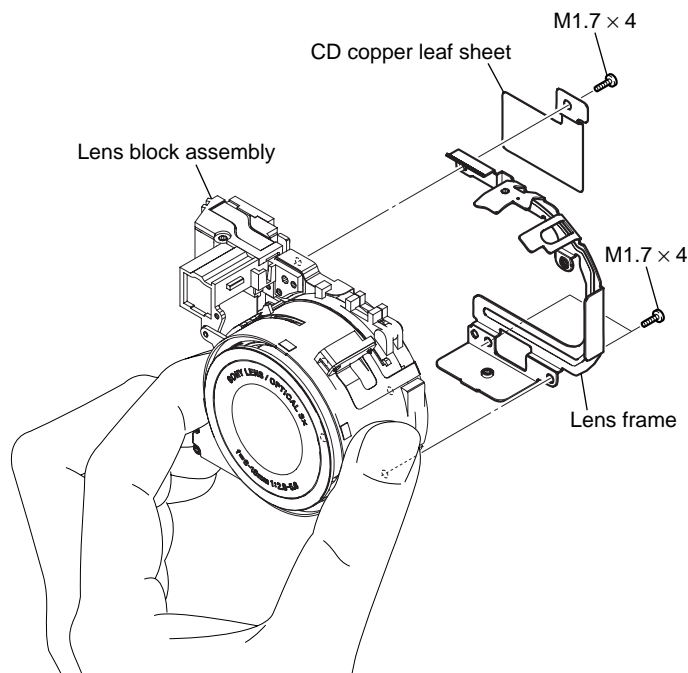

1-4. DESCRIPTION ON SELF-DIAGNOSIS DISPLAY

Self-diagnosis display

The camera has a self-diagnosis display. This function displays the camera condition with five-digits (a combination of a letter and figures) on the LCD screen. If this occurs check the following code chart. The five-digits display informs you of the camera's current condition. The last two digits (indicated by □□) will differ depending on the state of the camera.

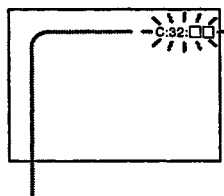

Self-diagnosis display

- C: □□: □□
You can reverse the camera malfunction yourself. (However, contact your Sony dealer or local authorized Sony service facility when you cannot recover from the camera malfunction.)
- E: □□: □□
Contact your Sony dealer or local authorized Sony service facility.

Display Code	Countermeasure	Cause	Caution Display During Error
C:32:□□	Turn the power off and on again.	Trouble with hardware.	SYSTEM ERROR
C:13:□□	Format the "Memory stick".	Unformatted memory stick is inserted.	FORMAT ERROR
	Insert a new "Memory Stick".	Memory stick is broken.	MEMORY STICK ERROR
E:61:□□	Checking of lens drive circuit.	When failed in the focus and zoom initialization.	—
E:91:□□	Checking of flash unit or replacement of flash unit.	Abnormality when flash is being charged.	
E:92:□□	Insert batteries correctly.	Batteries are not inserted correctly.	
	Turn the power off and on again.	Batteries were installed or removed when using the AC adaptor.	

SECTION 2
DISASSEMBLY

2-1. FLOW CHART

The following flow chart shows the disassembly procedure.

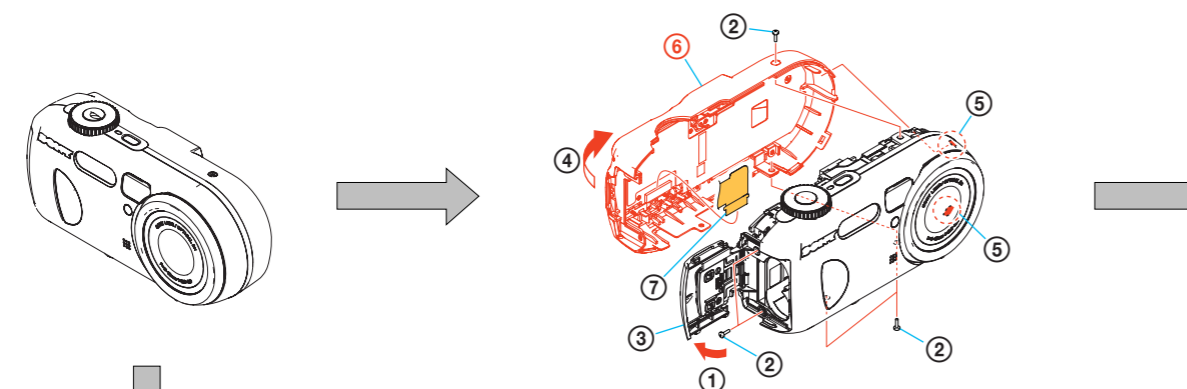

- ① Open the BT lid.
- ② Screw (M1.7) x5
- ③ Close the BT lid.
- ④ Open rear cabinet in the direction of arrow.
- ⑤ Claw x2
- ⑥ Rear cabinet
- ⑦ FP-859: CN201

Note: Flexible board is connected.

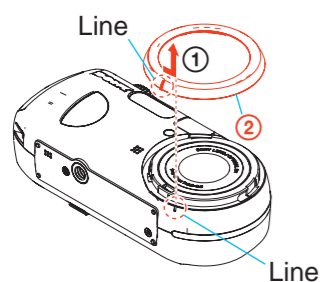

- ① Turn Lens ring to the position which the line of Lens ring and the line of Front cabinet suit.

② Lens ring

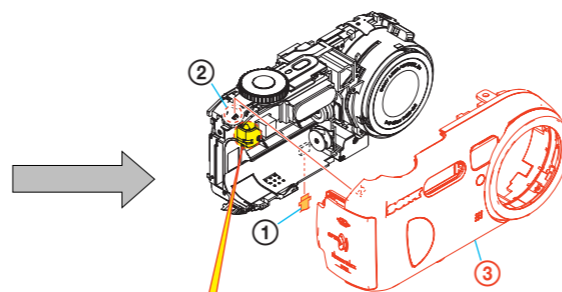

- ① Mic unit flexible: CN707
- ② Claw
- ③ Front cabinet

Note: High-voltage cautions

Discharging the Capacitor
Short-circuit between the two points with the short jig about 10 seconds.

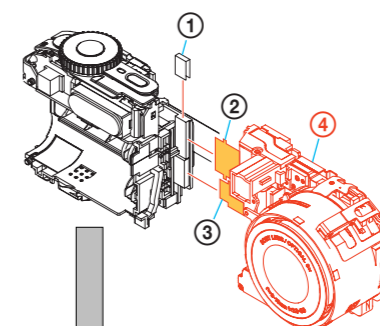
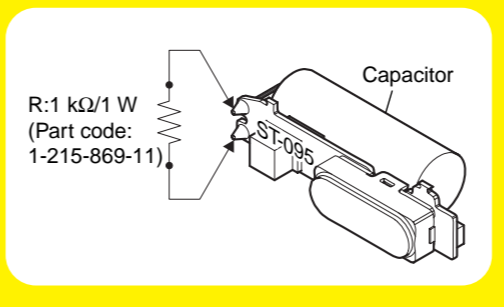

- ① Tape (A) **HELP**
- ② FP-854: CN702
- ③ Lens block flexible:601
- ④ Lens block

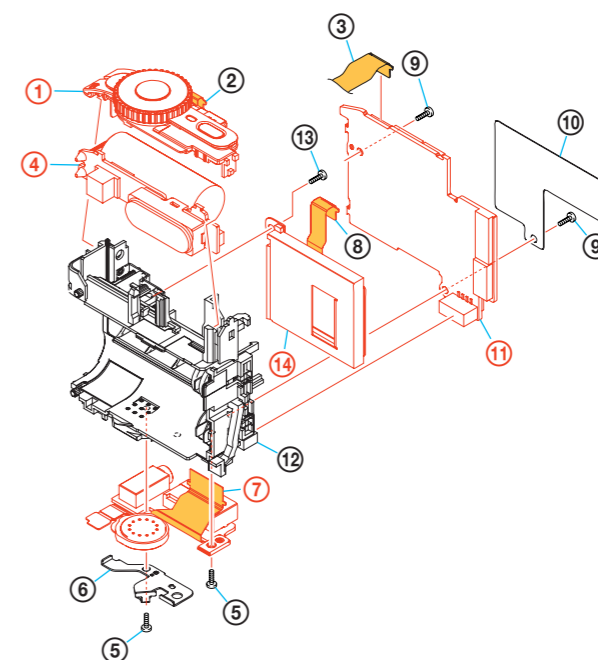

- ① Control switch block
- ② Control switch block flexible: CN706
- ③ FP-852: CN703
- ④ ST-095
- ⑤ Tapping screw x2
- ⑥ SP retainer plate
- ⑦ FP-860: CN751
- ⑧ FP-861: CN705
- ⑨ Tapping screw x2
- ⑩ SY copper leaf sheet
- ⑪ SY-100
- ⑫ BT harness: CN001
- ⑬ Tapping screw x1
- ⑭ MS

Refer to "5-1-3. BT HOLDER BLOCK SECTION" (Page 5-4) for details.

2-2. SY-100 BOARD SERVICE POSITION

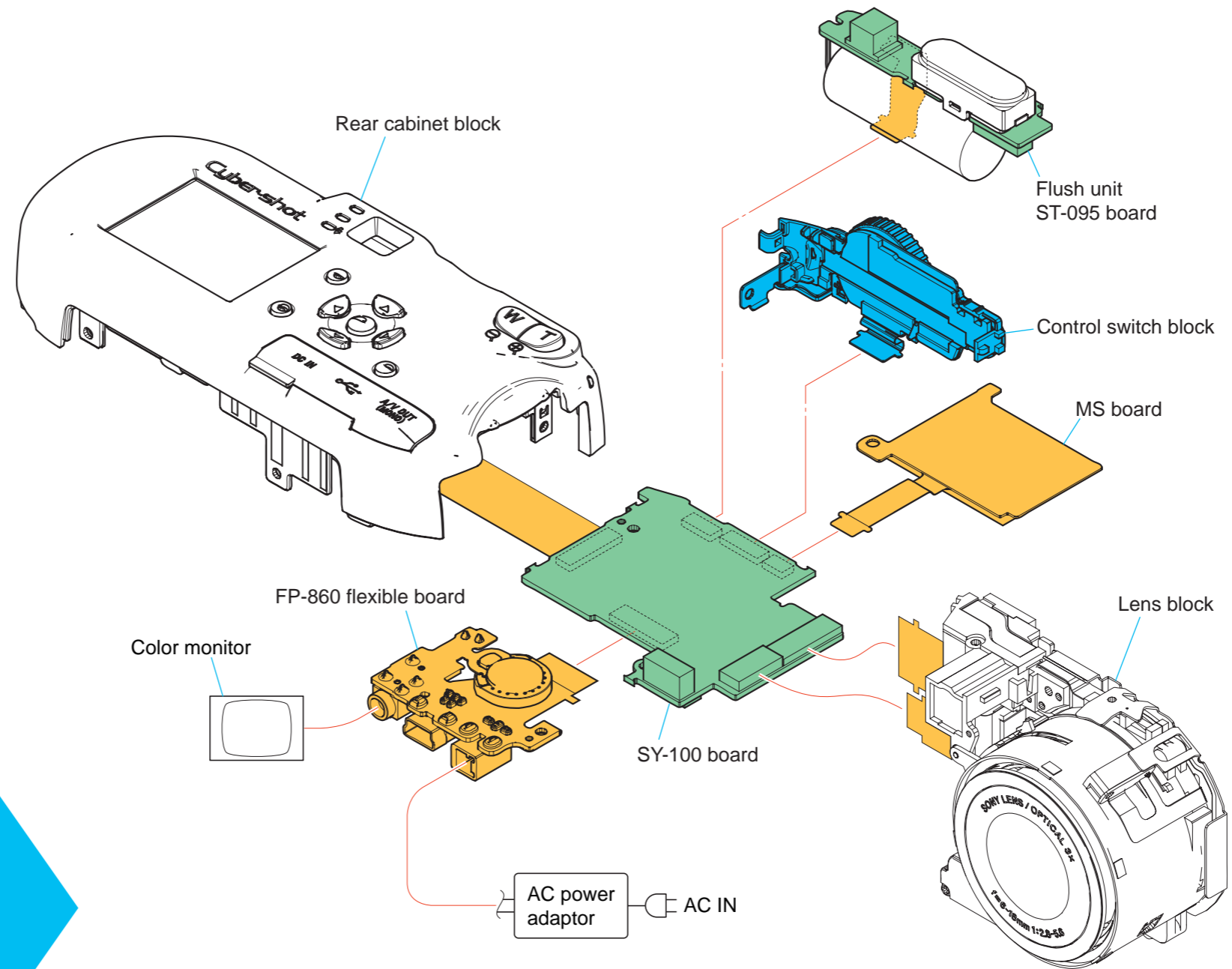
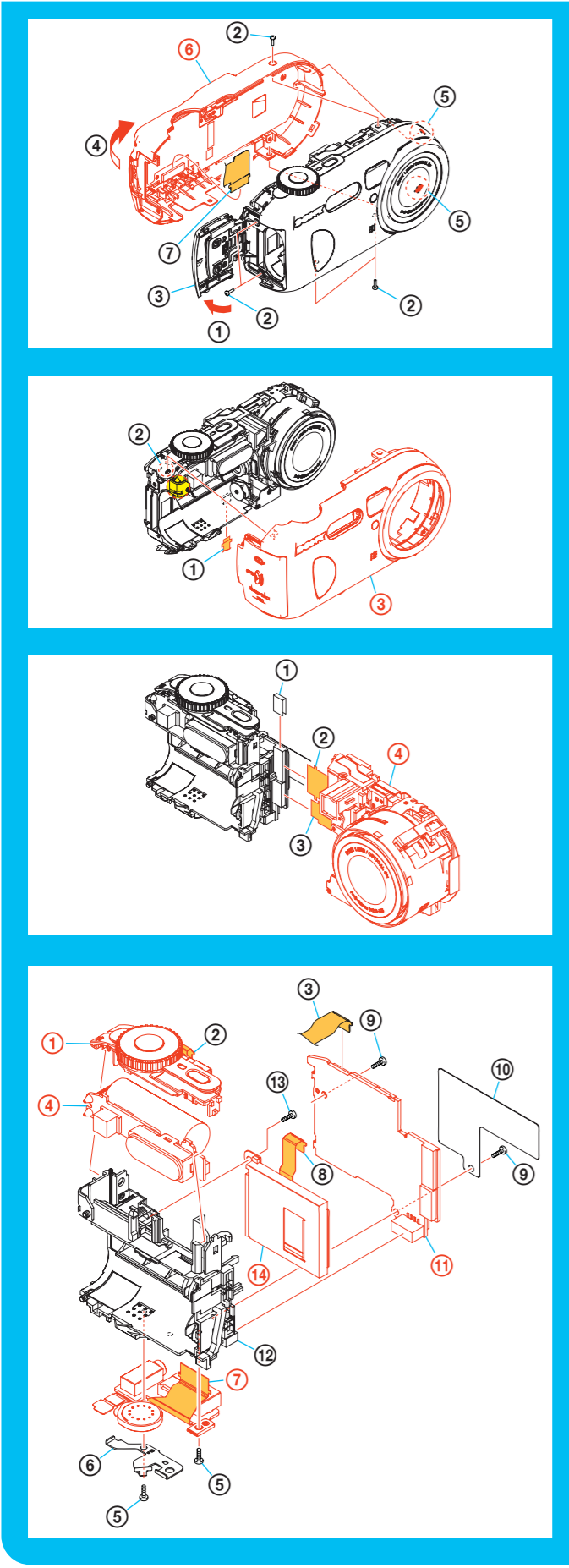

2-3. CIRCUIT BOARDS LOCATION

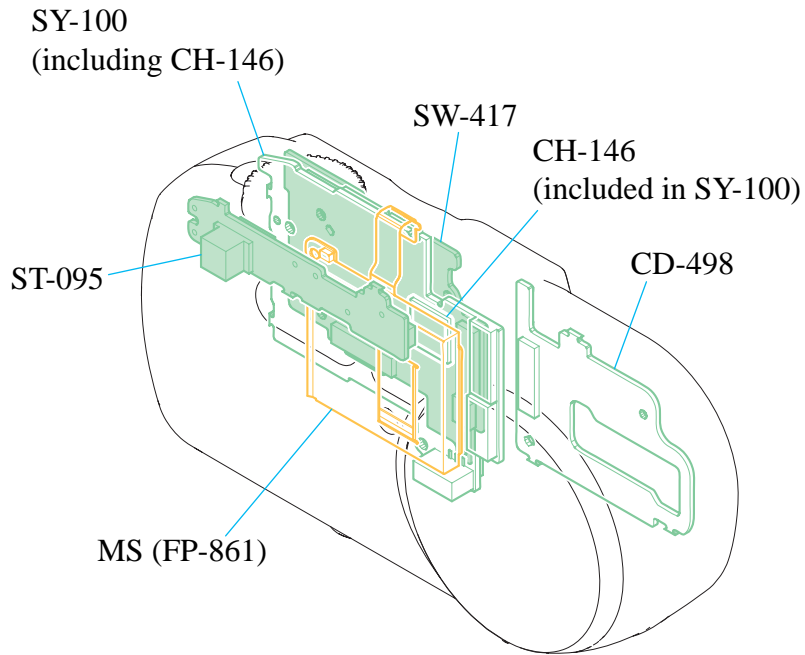

Board Name	Function
CD-498	CCD IMAGER
CH-146 (included in SY-100)	CCD SIGNAL PROCESS
MS (FP-861)	MEMORY STICK CONNECTOR
ST-095	FLASH DRIVE
SW-417	CONTROL SWITCH, LCD DRIVE
SY-100 (Including CH-146)	CAMERA MODULE, CAMERA DSP, LENS DRIVE, SH DSP, FRONT CONTROL, AUDIO, DC/DC CONVERTER

2-4. FLEXIBLE BOARDS LOCATION

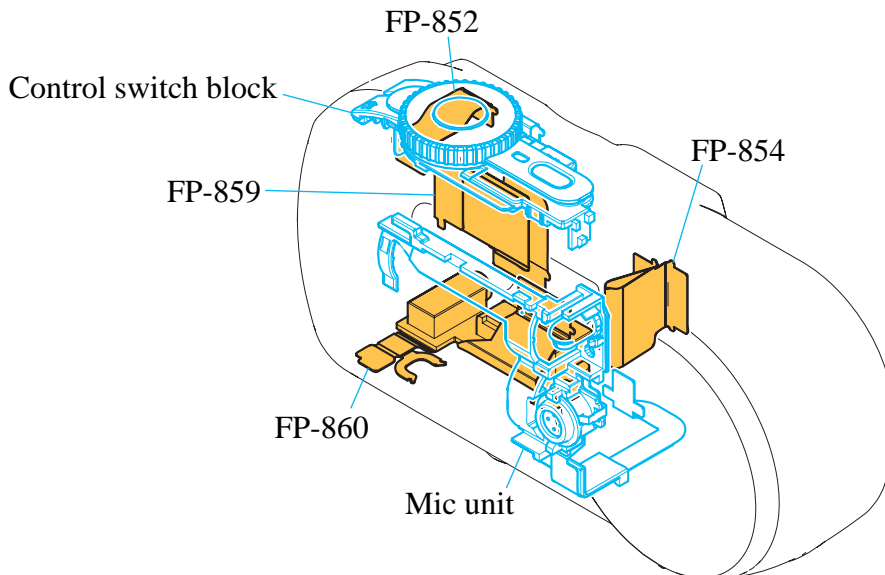

HELP

Sheet attachment positions and procedures of processing the flexible boards/harnesses are shown.

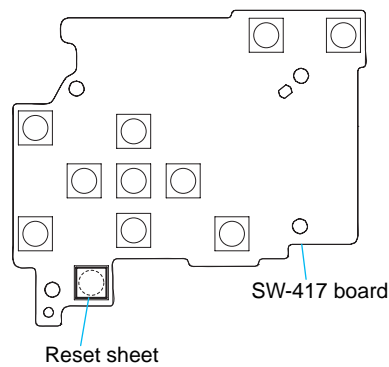
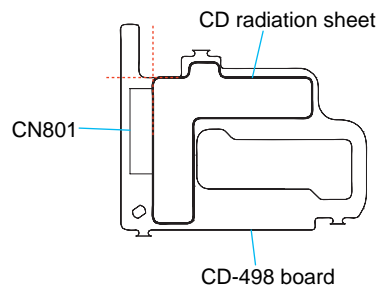
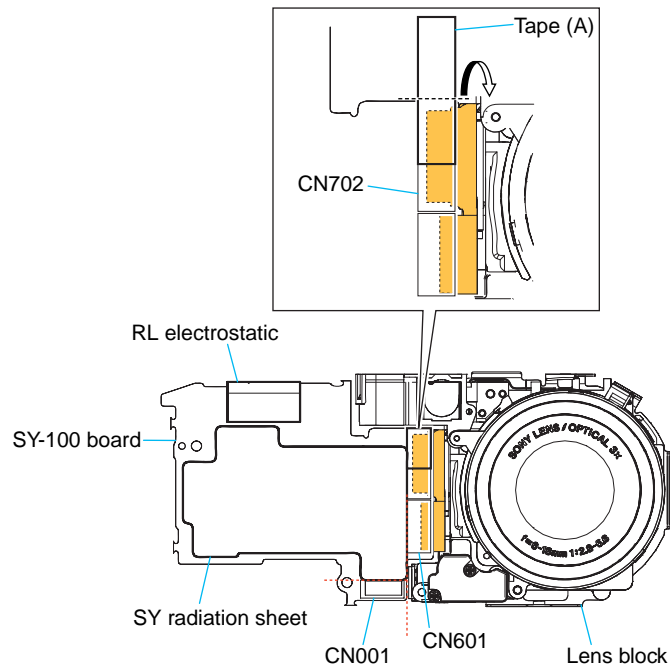

3. BLOCK DIAGRAMS

Link

• [OVERALL BLOCK DIAGRAM \(1/2\)](#)

• [POWER BLOCK DIAGRAM \(1/2\)](#)

• [OVERALL BLOCK DIAGRAM \(2/2\)](#)

• [POWER BLOCK DIAGRAM \(2/2\)](#)

SECTION 3
BLOCK DIAGRAMS

3. BLOCK DIAGRAMS

3-1. OVERALL BLOCK DIAGRAM (1/2) () : Number in parenthesis () indicates the division number of schematic diagram where the component is located.

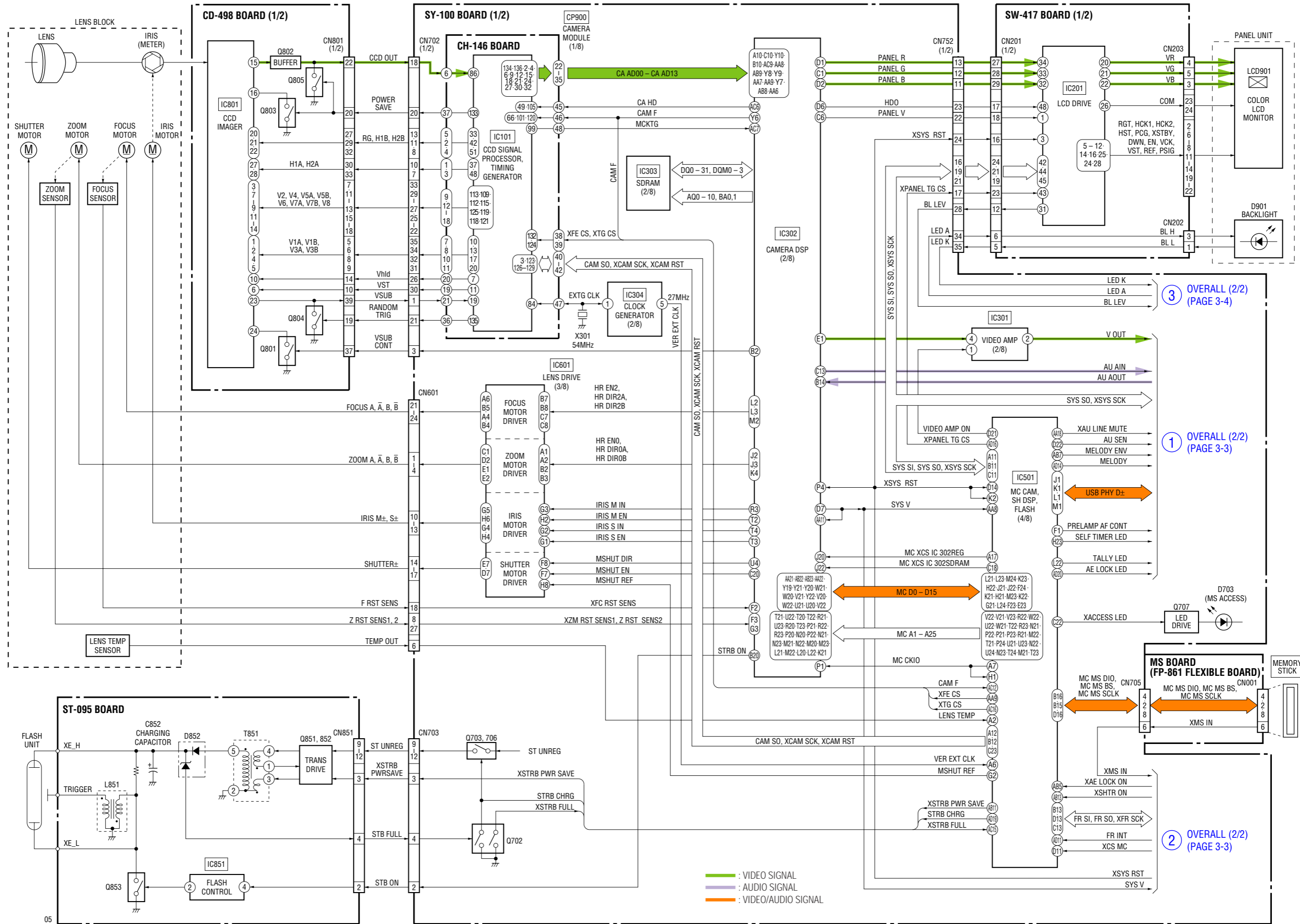

3. BLOCK DIAGRAMS

3-2. OVERALL BLOCK DIAGRAM (2/2) () : Number in parenthesis () indicates the division number of schematic diagram where the component is located.

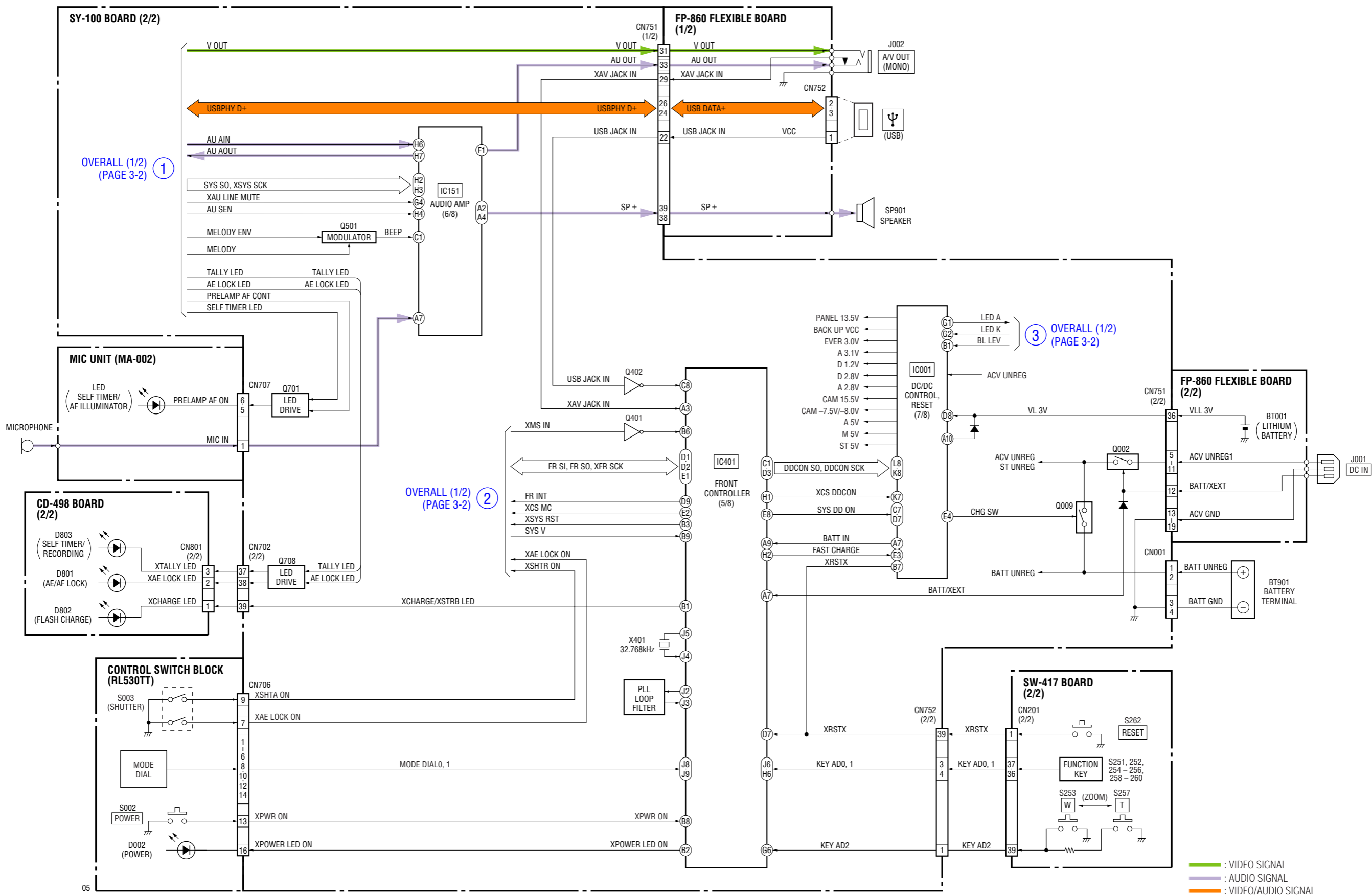

3. BLOCK DIAGRAMS

3-3. POWER BLOCK DIAGRAM (1/2) () : Number in parenthesis () indicates the division number of schematic diagram where the component is located.

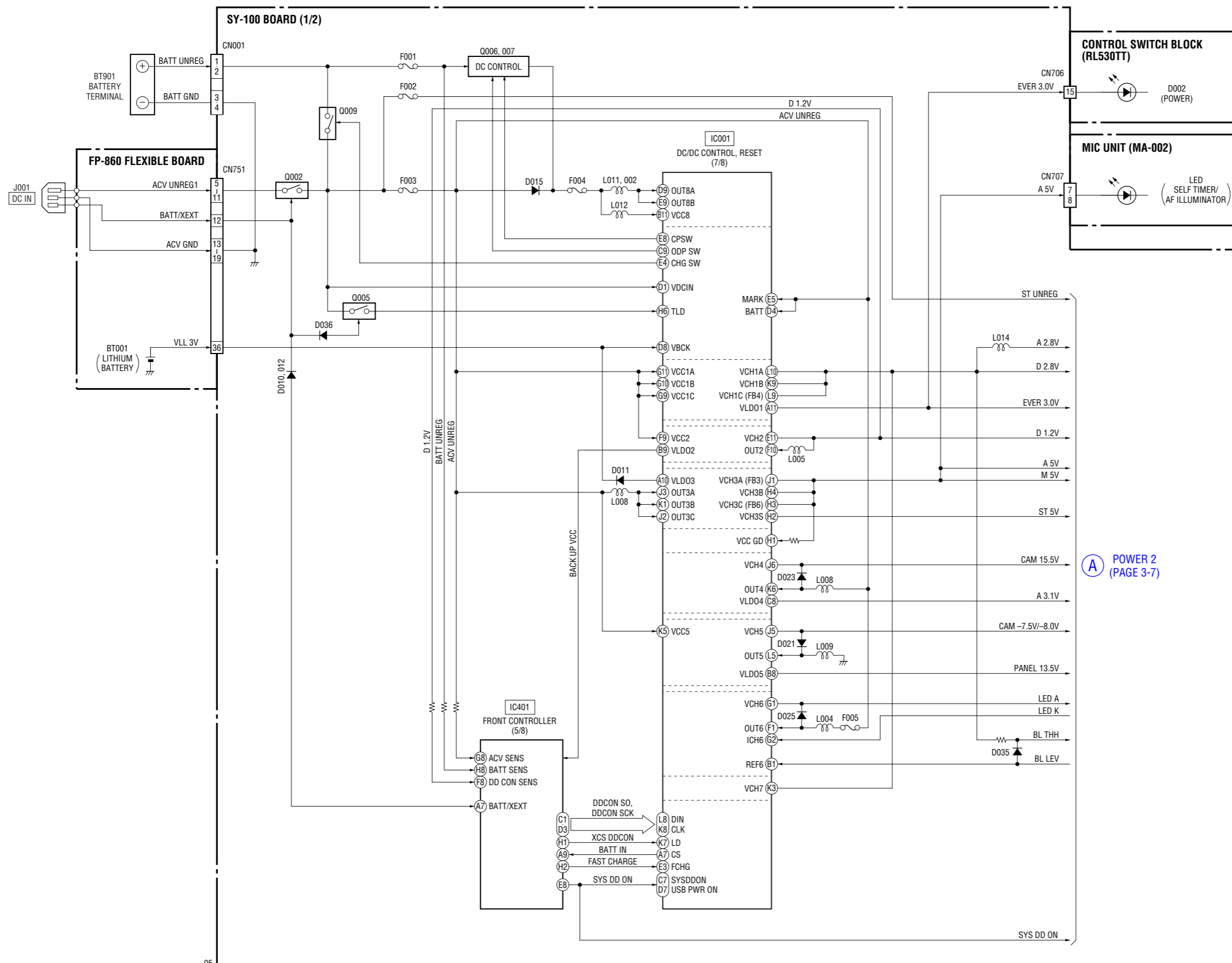

A POWER 2 (PAGE 3-7)

3. BLOCK DIAGRAMS

3-4. POWER BLOCK DIAGRAM (2/2) () : Number in parenthesis () indicates the division number of schematic diagram where the component is located.

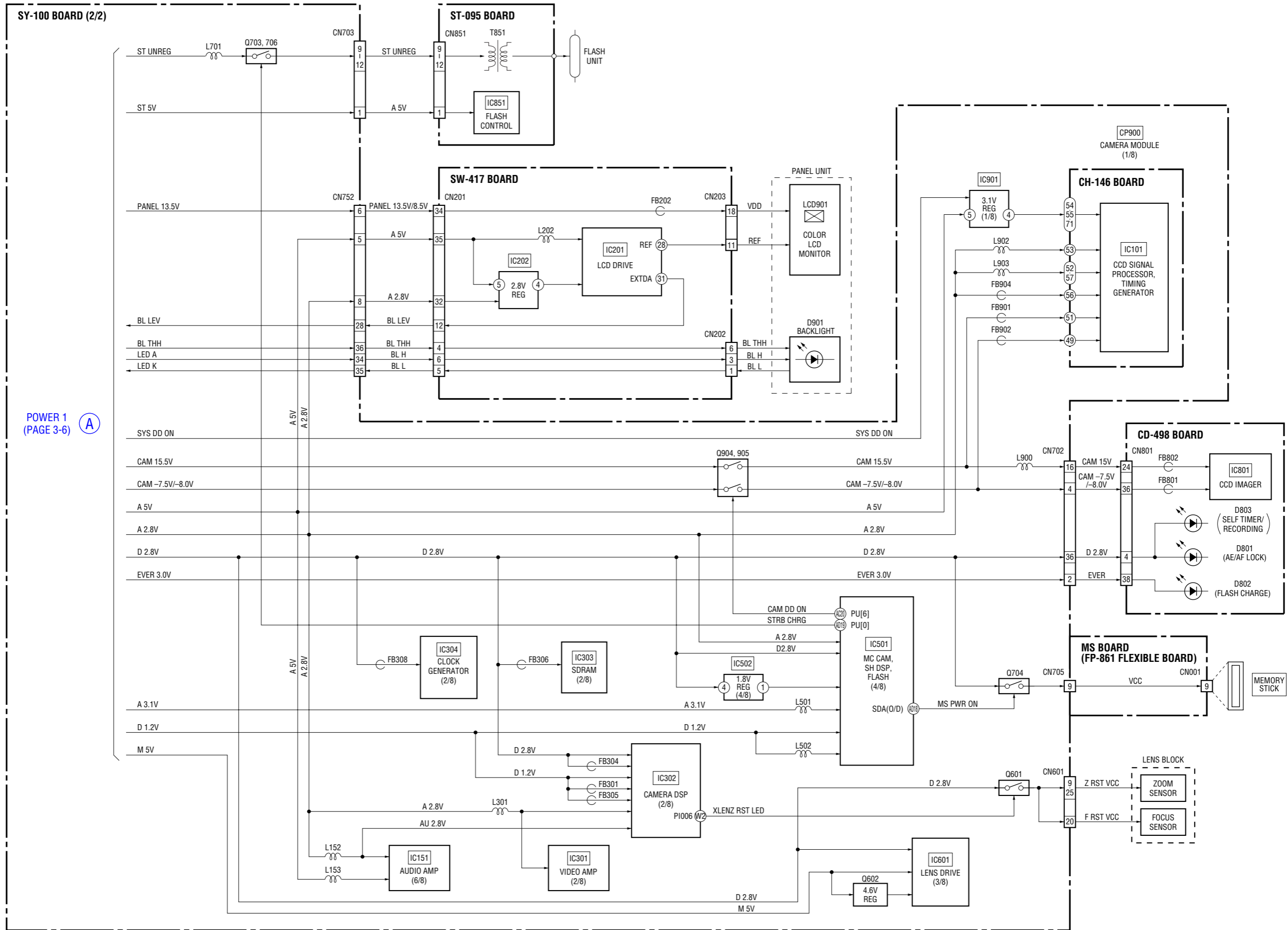

POWER 1 (PAGE 3-6) (A)

SECTION 4

PRINTED WIRING BOARDS AND SCHEMATIC DIAGRAMS

4-1. FRAME SCHEMATIC DIAGRAM

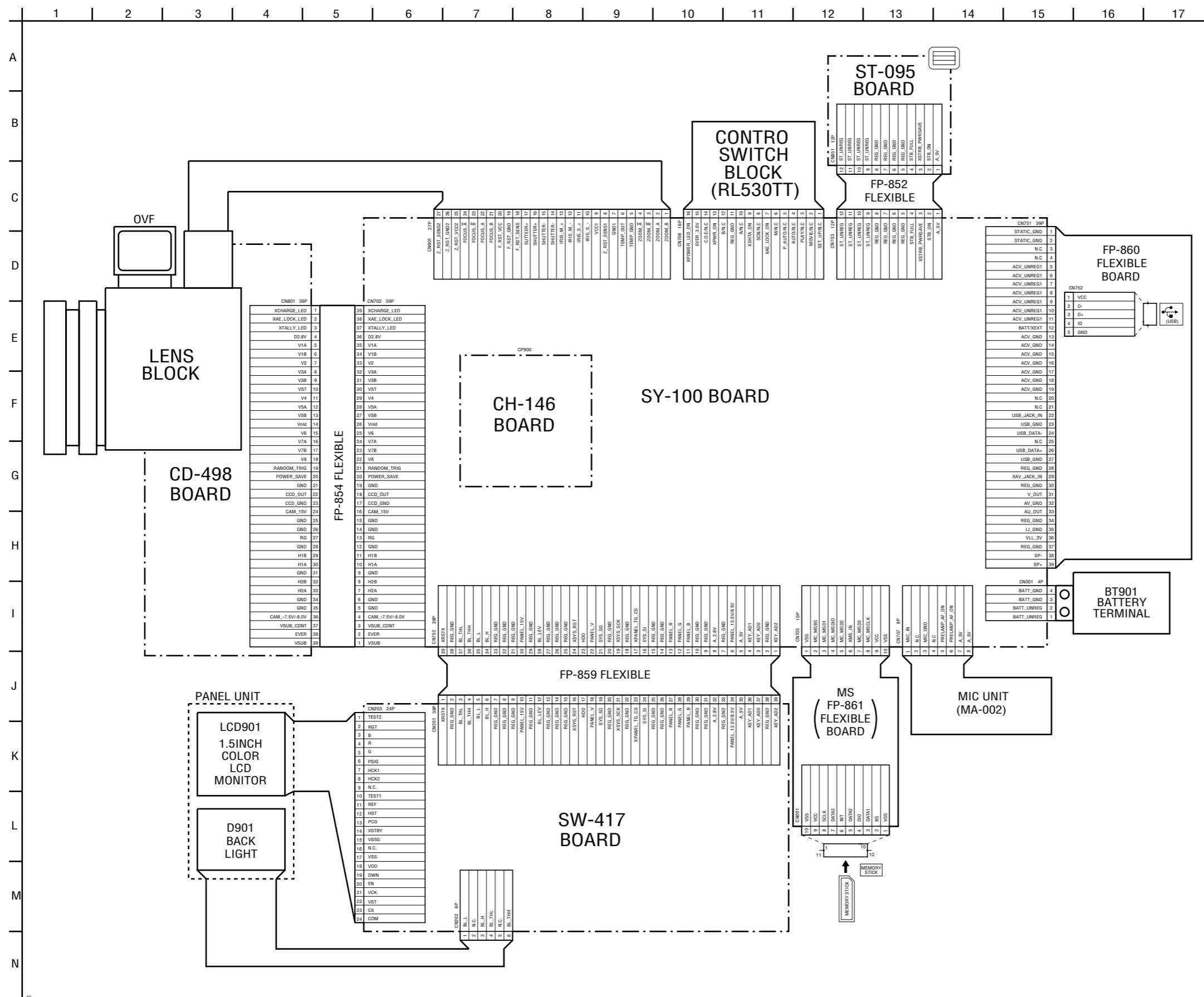

4-2. SCHEMATIC DIAGRAMS

Link

<ul style="list-style-type: none">• CD-498 BOARD (CCD IMAGER)	<ul style="list-style-type: none">• FP-860 FLEXIBLE BOARD (JACK)
<ul style="list-style-type: none">• SW-417 BOARD (CONTROL SWITCH, LCD DRIVE)	<ul style="list-style-type: none">• MIC UNIT (MA-002)
<ul style="list-style-type: none">• ST-095 BOARD (FLASH DRIVE)	<ul style="list-style-type: none">• CONTROL SWITCH BLOCK (RL530TT)
<ul style="list-style-type: none">• MS BOARD (FP-861 FLEXIBLE BOARD) (MEMORY STICK CONNECTOR)	
<ul style="list-style-type: none">• COMMON NOTE FOR SCHEMATIC DIAGRAMS	

4-2. SCHEMATIC DIAGRAMS

4-2. SCHEMATIC DIAGRAMS

THIS NOTE IS COMMON FOR SCHEMATIC DIAGRAMS
 (In addition to this, the necessary note is printed in each block)

(For schematic diagrams)

- All capacitors are in μF unless otherwise noted. $\text{pF} : \mu\text{F} : 50\text{V}$ or less are not indicated except for electrolytics and tantalums.
- Chip resistors are $1/10\text{W}$ unless otherwise noted. $\text{k}\Omega=1000\ \Omega$, $\text{M}\Omega=1000\ \text{k}\Omega$.
- Caution when replacing chip parts. New parts must be attached after removal of chip. Be careful not to heat the minus side of tantalum capacitor, Because it is damaged by the heat.
- Some chip part will be indicated as follows.

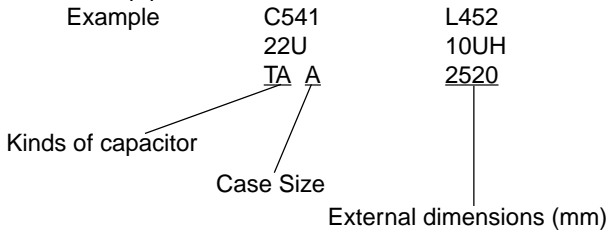

- Constants of resistors, capacitors, ICs and etc with XX indicate that they are not used. In such cases, the unused circuits may be indicated.
- Parts with ★ differ according to the model/destination. Refer to the mount table for each function.
- All variable and adjustable resistors have characteristic curve B, unless otherwise noted.
- Signal name
 $\text{XEDIT} \rightarrow \text{EDIT}$ $\text{PB/XREC} \rightarrow \text{PB/REC}$
- : non flammable resistor
- : fusible resistor
- : panel designation
- : B+ Line
- : B- Line
- : IN/OUT direction of (+,-) B LINE.
- : adjustment for repair.
- : VIDEO SIGNAL (ANALOG)
- : AUDIO SIGNAL (ANALOG)
- : VIDEO/AUDIO SIGNAL
- : VIDEO/AUDIO/SERVO SIGNAL
- : SERVO SIGNAL
- Circled numbers refer to waveforms.

(Measuring conditions voltage and waveform)

- Voltages and waveforms are measured between the measurement points and ground when camera shoots color bar chart of pattern box. They are reference values and reference waveforms. (VOM of DC $10\text{M}\Omega$ input impedance is used)
- Voltage values change depending upon input impedance of VOM used.)

Note : The components identified by mark Δ or dotted line with mark Δ are critical for safety. Replace only with part number specified.

1. Connection

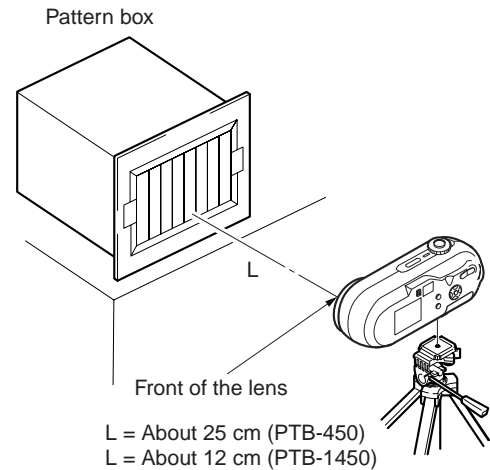

2. Adjust the distance so that the output waveform of Fig. a and the Fig. b can be obtain.

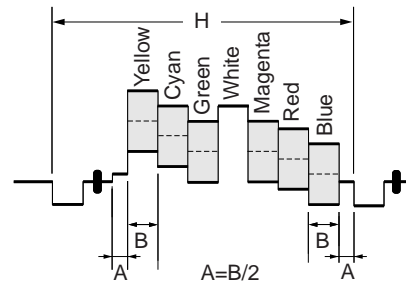

Fig. a (Video output terminal output waveform)

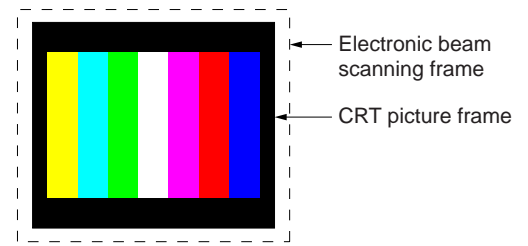

Fig.b (Picture on monitor TV)

When indicating parts by reference number, please include the board name.

Note : Les composants identifiés par une marque Δ sont critiques pour la sécurité. Ne les remplacer que par une pièce portant le numéro spécifiée.

4-2. SCHEMATIC DIAGRAMS CD-498 BOARD

For Schematic Diagram

• Refer to page 4-37 for printed wiring board.

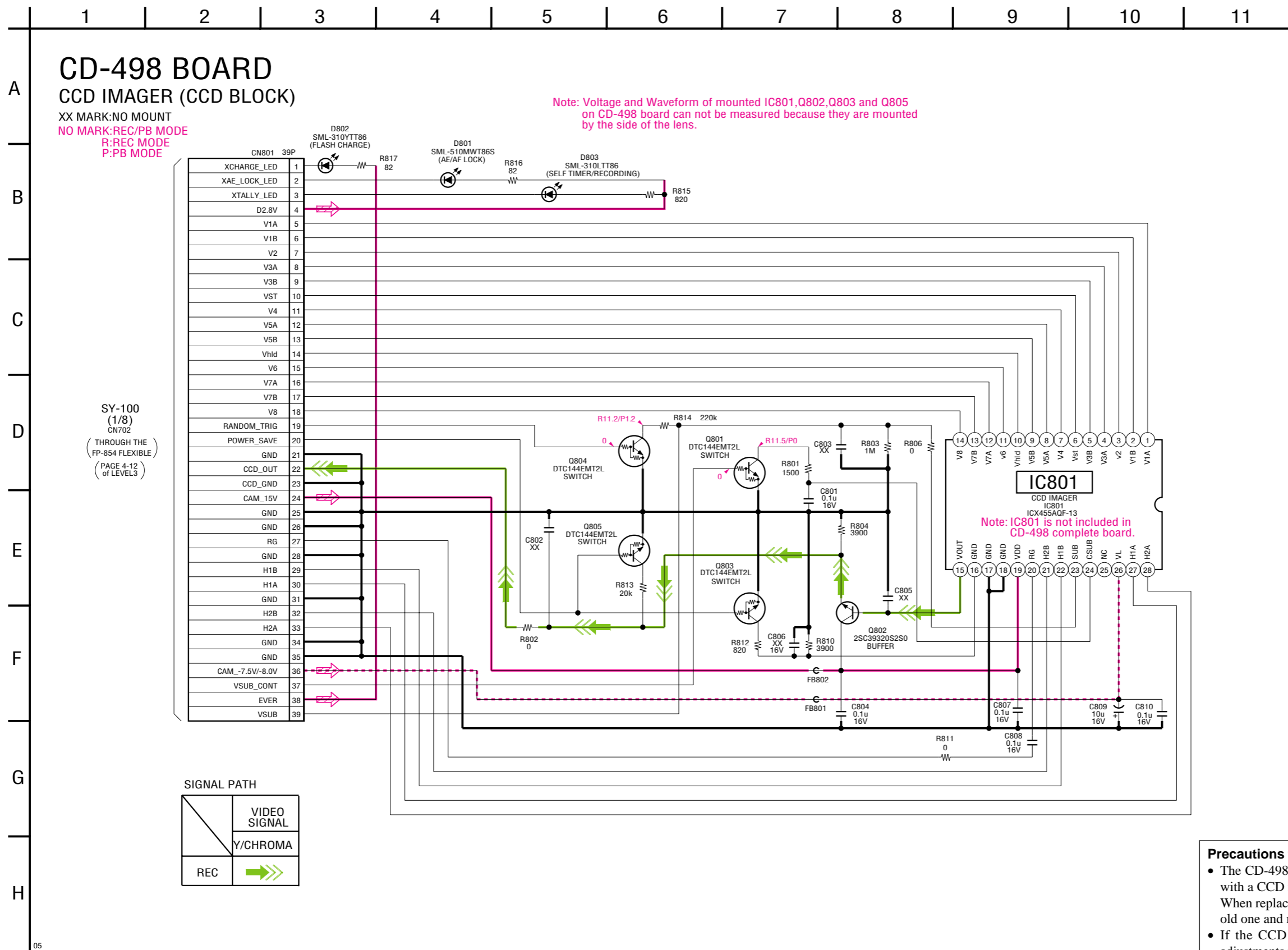

Precautions for Replacement of CCD Imager

- The CD-498 board mounted as a repair part is not equipped with a CCD imager. When replacing this board, remove the CCD imager from the old one and mount it onto the new one.
- If the CCD imager has been replaced, carry out all the adjustments for the camera section.
- As the CCD imager may be damaged by static electricity from its structure, handle it carefully like for the MOS IC. In addition, ensure that the receiver is not covered with dusts nor exposed to strong light.

Schematic diagrams of the CH-146 and SY-100 boards are not shown.
Pages from 4-9 to 4-26 are not shown.

4-2. SCHEMATIC DIAGRAMS SW-417 BOARD

For Schematic Diagram
 • Refer to page 4-43 for printed wiring board.

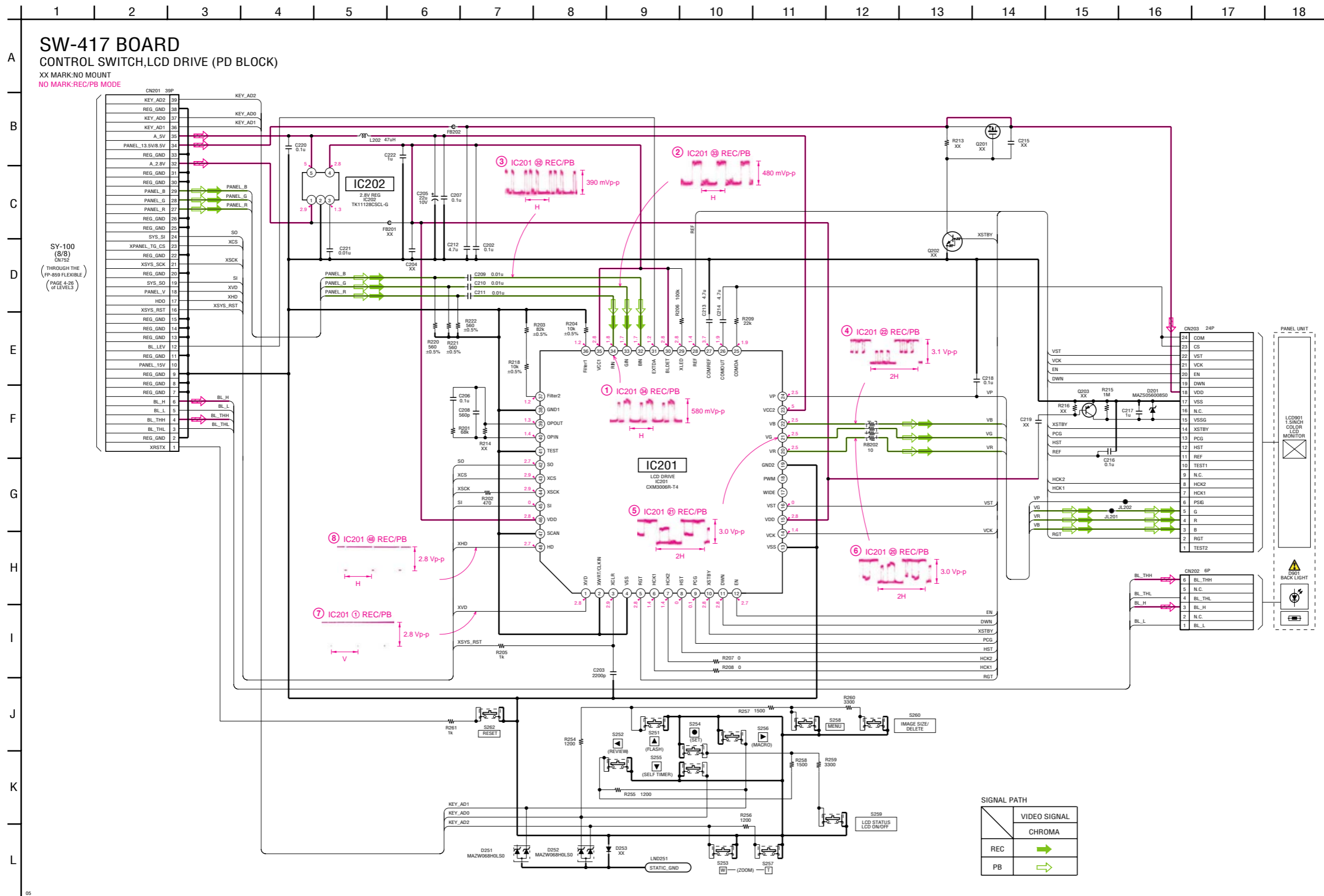

The components identified by mark Δ or dotted line with mark Δ are critical for safety. Replace only with part number specified.

Les composants identifiés par une marque Δ sont critiques pour la sécurité. Ne les remplacer que par une pièce portant le numéro spécifié.

4-2. SCHEMATIC DIAGRAMS ST-095 BOARD

For Schematic Diagram
 • Refer to page 4-45 for printed wiring board.

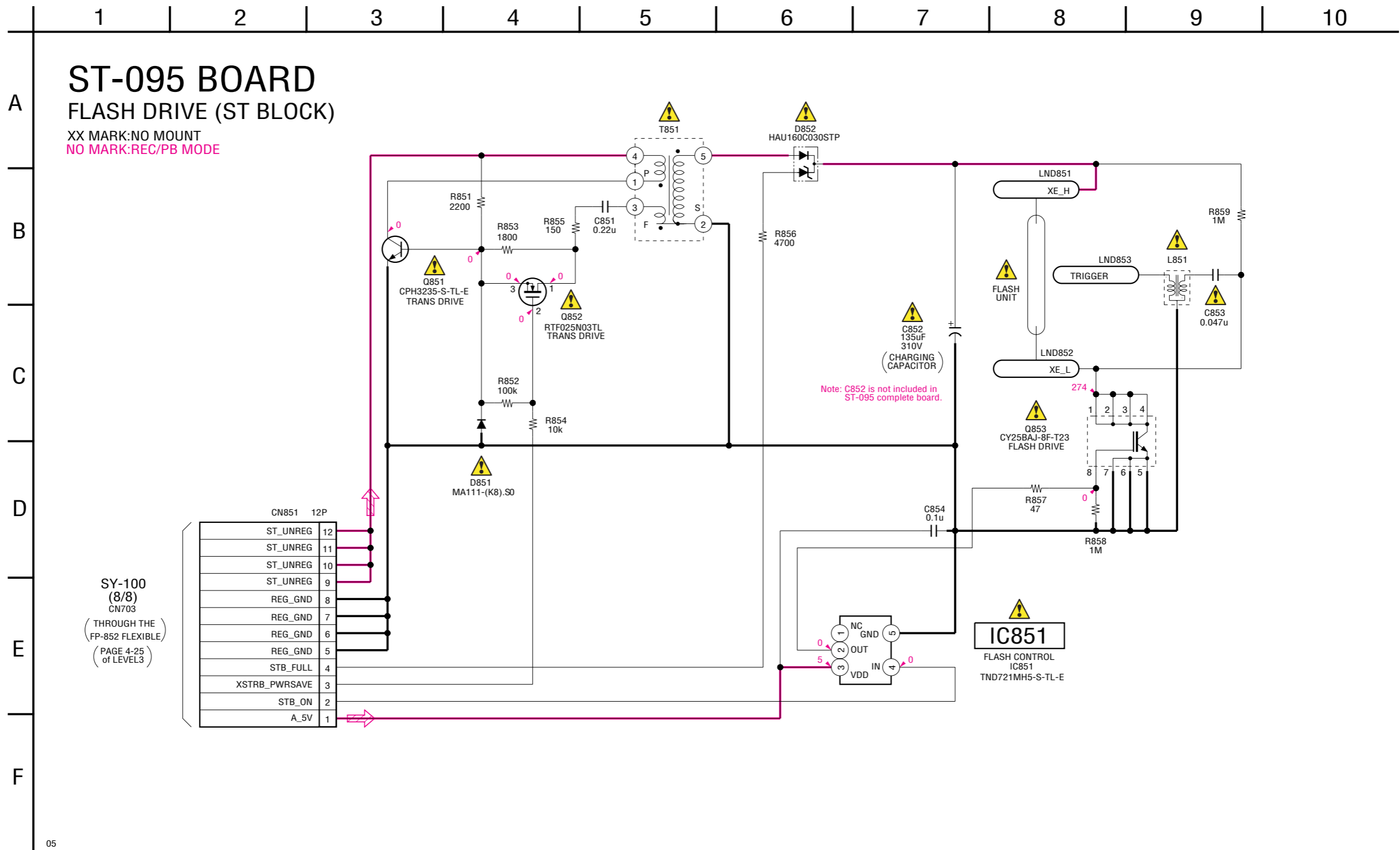

The components identified by mark \triangle or dotted line with mark \triangle are critical for safety. Replace only with part number specified.

Les composants identifiés par une marque \triangle sont critiques pour la sécurité. Ne les remplacer que par une pièce portant le numéro spécifié.

4-2. SCHEMATIC DIAGRAMS

MS BOARD

FP-860 FLEXIBLE BOARD

For Schematic Diagram

• Refer to page 4-47 for printed wiring board.

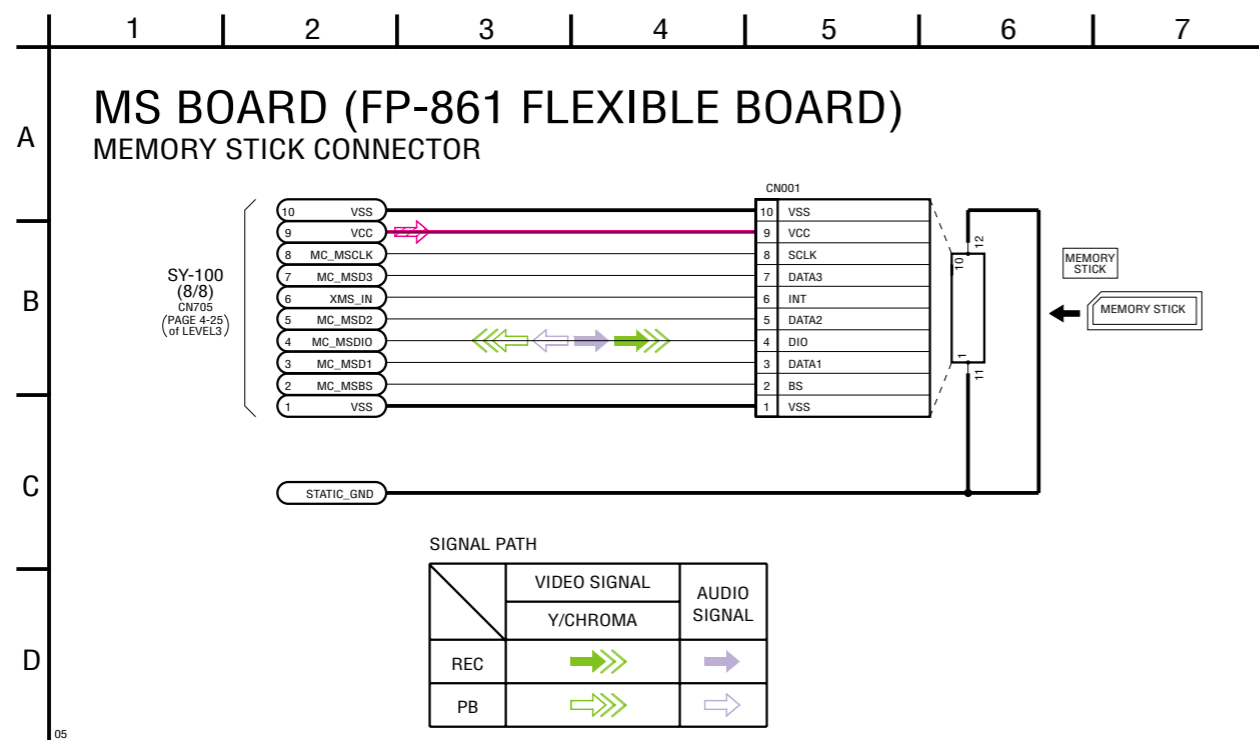

For Schematic Diagram

• Refer to page 4-48 for printed wiring board.

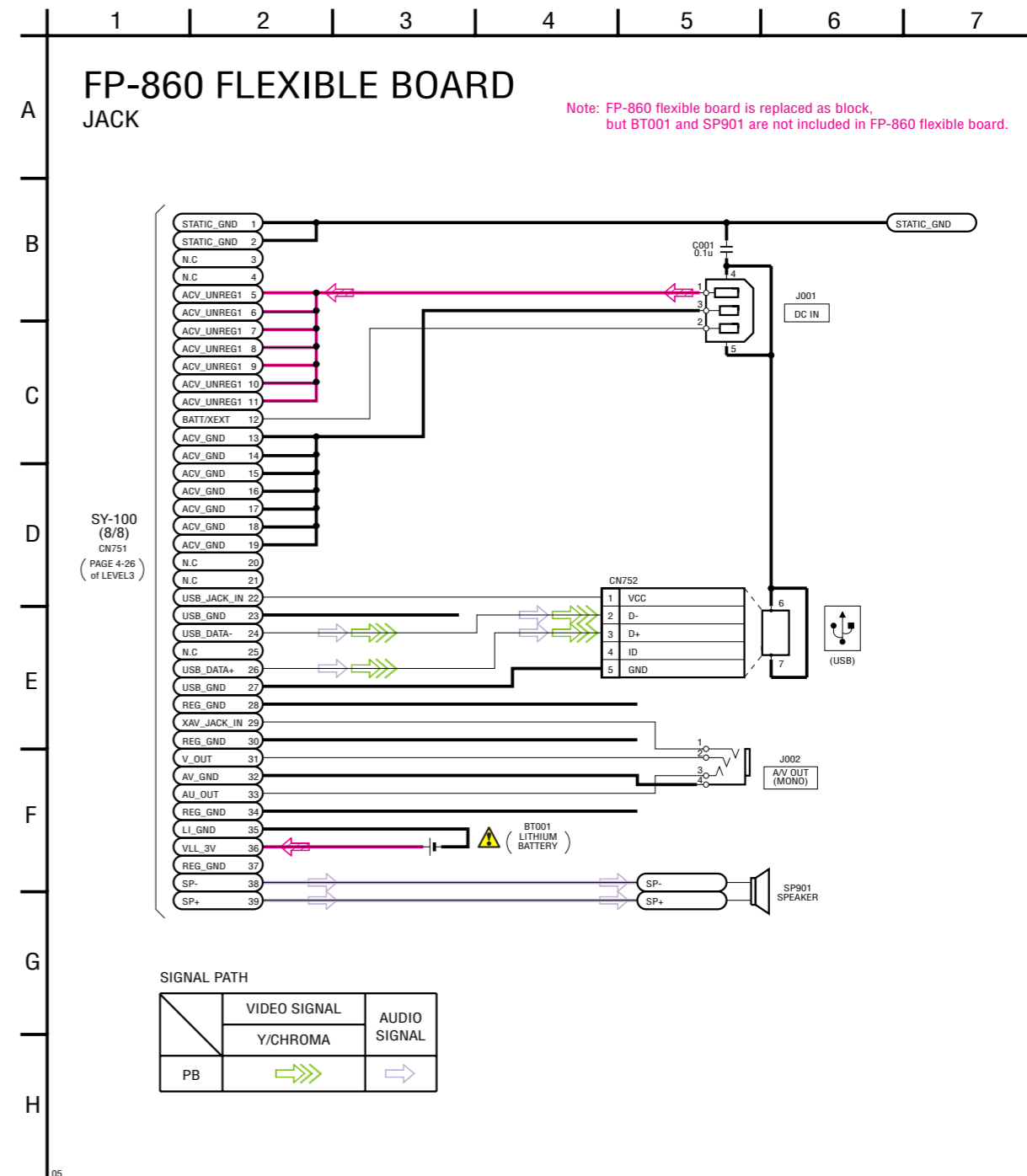

Note: FP-860 flexible board is replaced as block, but BT001 and SP901 are not included in FP-860 flexible board.

The components identified by mark \triangle or dotted line with mark \triangle are critical for safety. Replace only with part number specified.

Les composants identifiés par une marque \triangle sont critiques pour la sécurité. Ne les remplacer que par une pièce portant le numéro spécifié.

4-2. SCHEMATIC DIAGRAMS

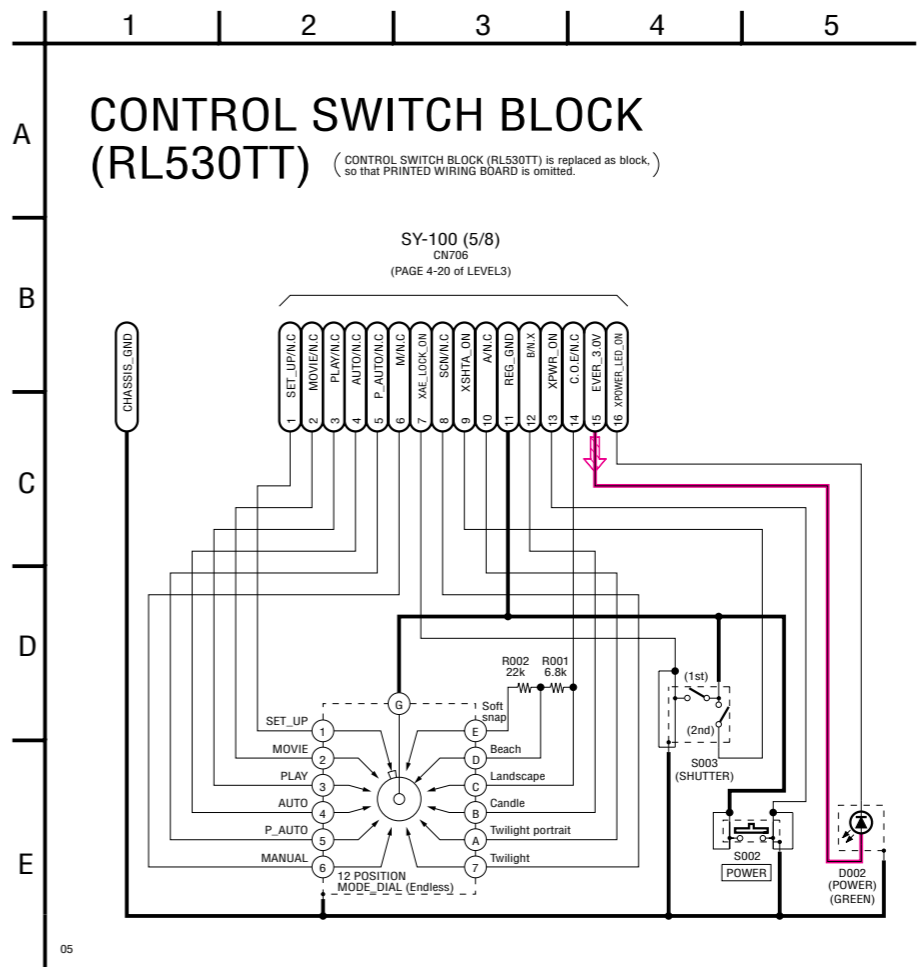
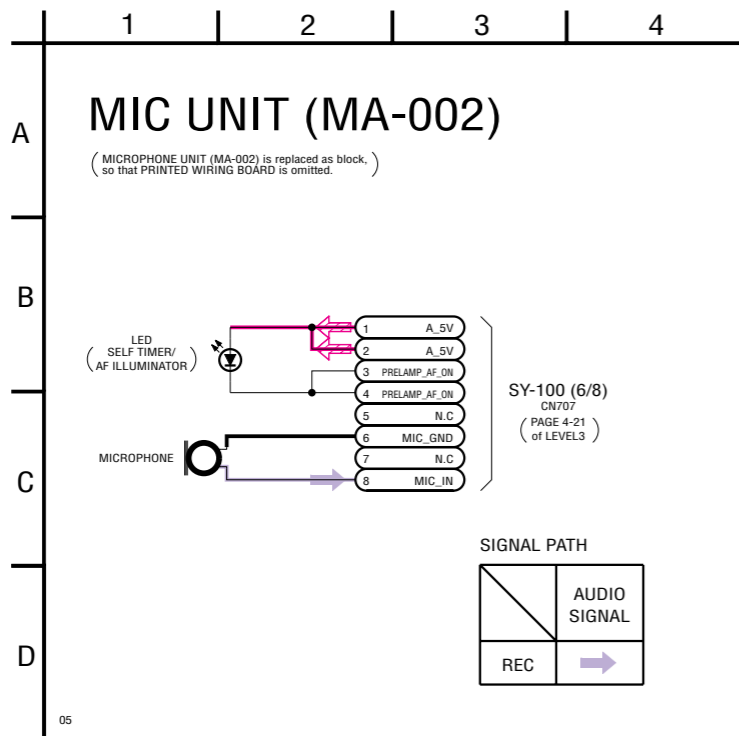

4-3. PRINTED WIRING BOARDS

Link

• CD-498 BOARD	• MS BOARD (FP-861 FLEXIBLE BOARD)
• SW-417 BOARD	• FP-860 FLEXIBLE BOARD
• ST-095 BOARD	

• COMMON NOTE FOR PRINTED WIRING BOARDS		
• MOUNTED PARTS LOCATION	• CIRCUIT BOARDS LOCATION	• FLEXIBLE BOARDS LOCATION

Board Name	Function
CD-498	CCD IMAGER
SW-417	CONTROL SWITCH, LCD DRIVE
ST-095	FLASH DRIVE
MS (FP-861)	MEMORY STICK CONNECTOR

CD-498

Note for Printed Wiring Board (See page 4-35).

 : Uses unleaded solder.

CD-498 BOARD (SIDE A)

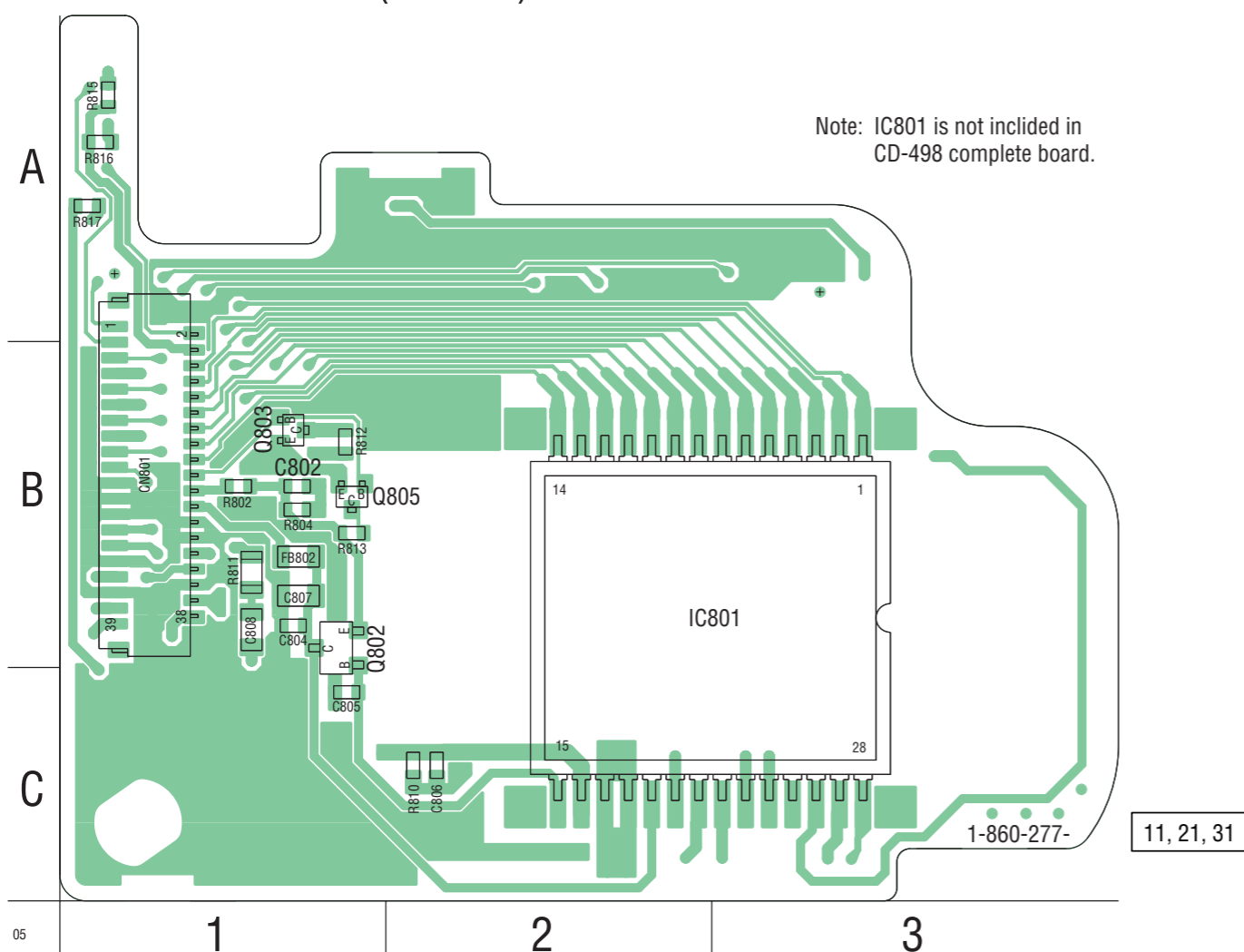

CD-498 BOARD (SIDE B)

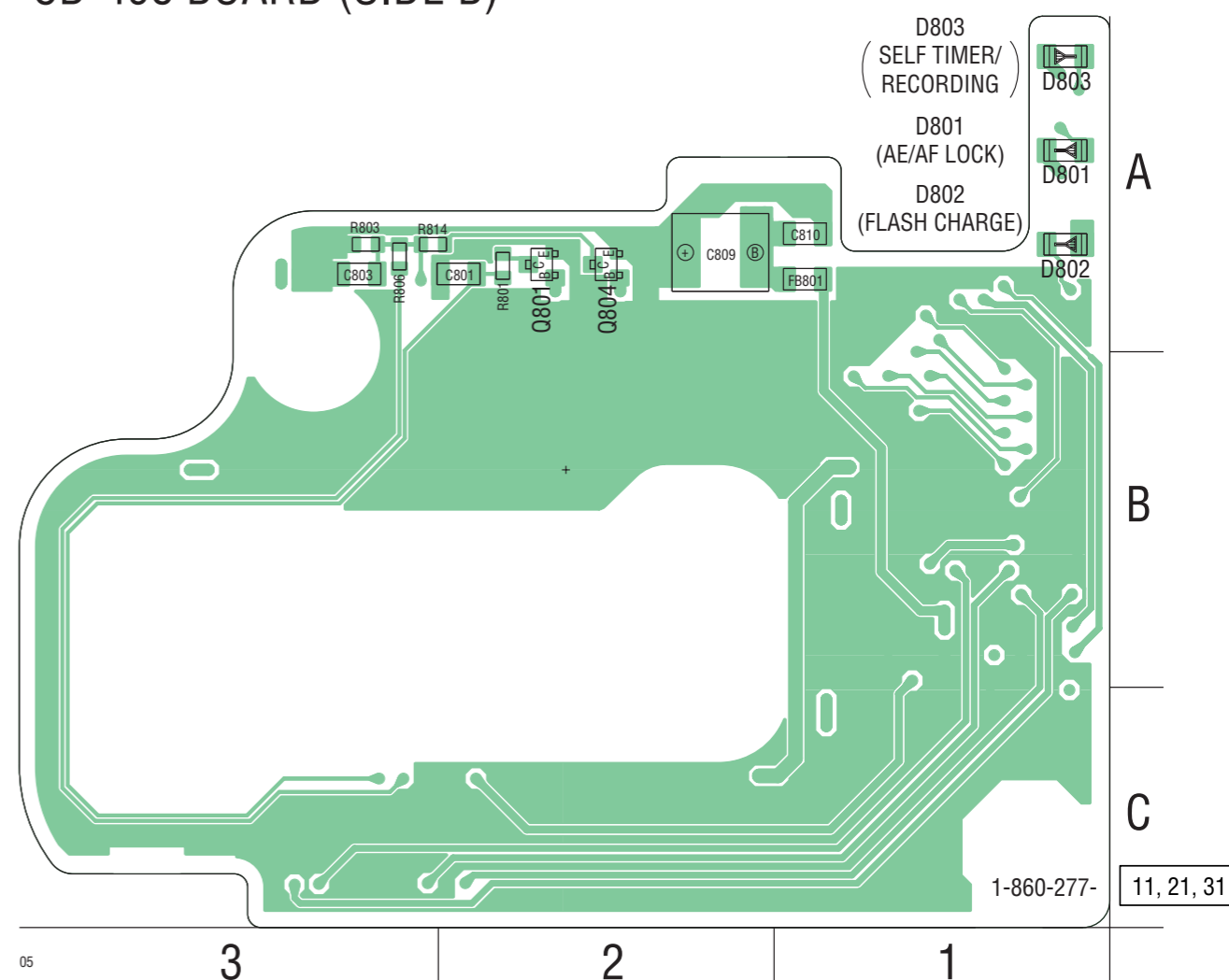

Printed wiring boards of the CH-146 and SY-100 boards are not shown.
Pages from 4-39 to 4-42 are not shown.

SW-417

Note for Printed Wiring Board (See page 4-35).

 : Uses unleaded solder.

SW-417 BOARD (SIDE A)

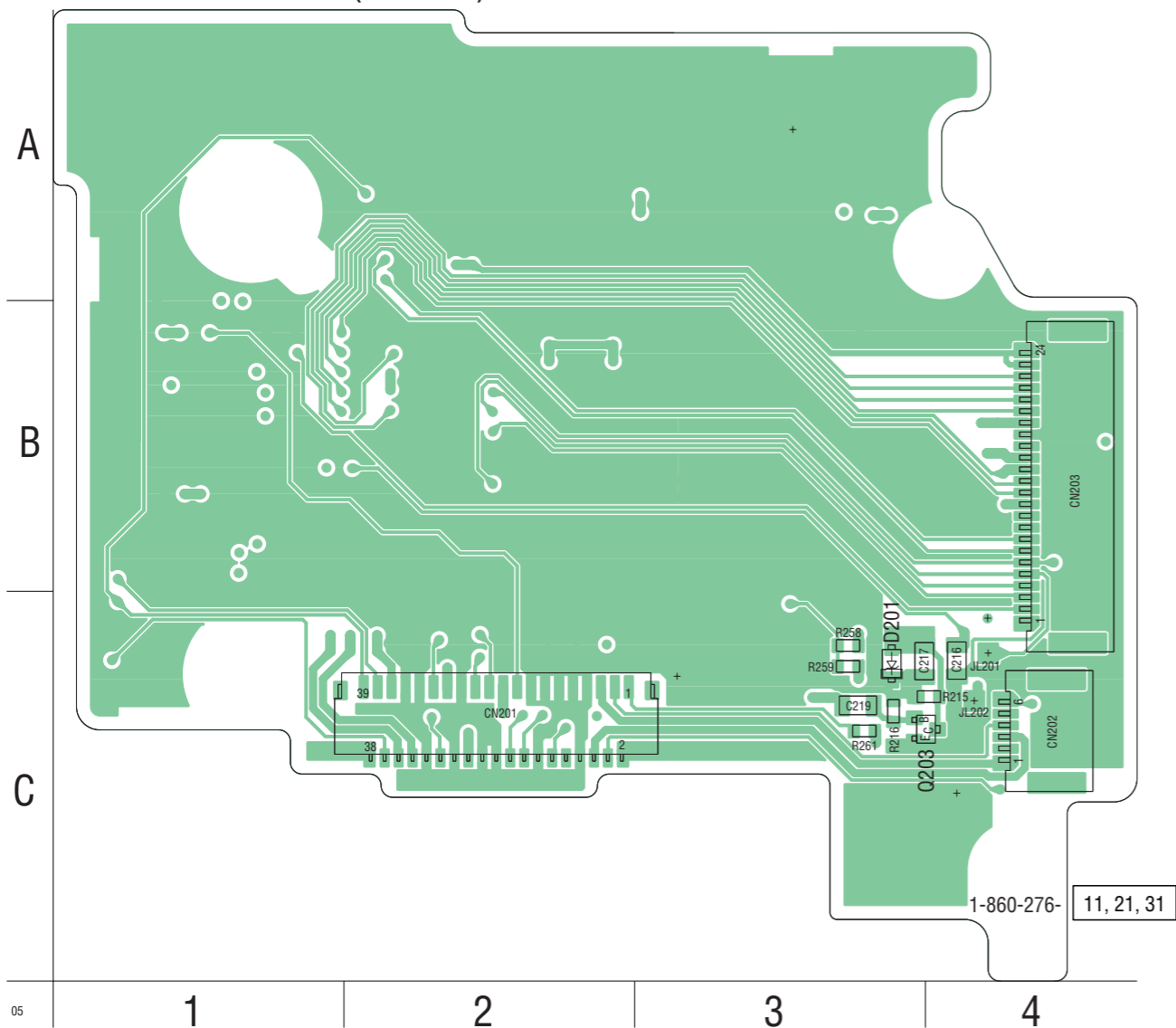

SW-417 BOARD (SIDE B)

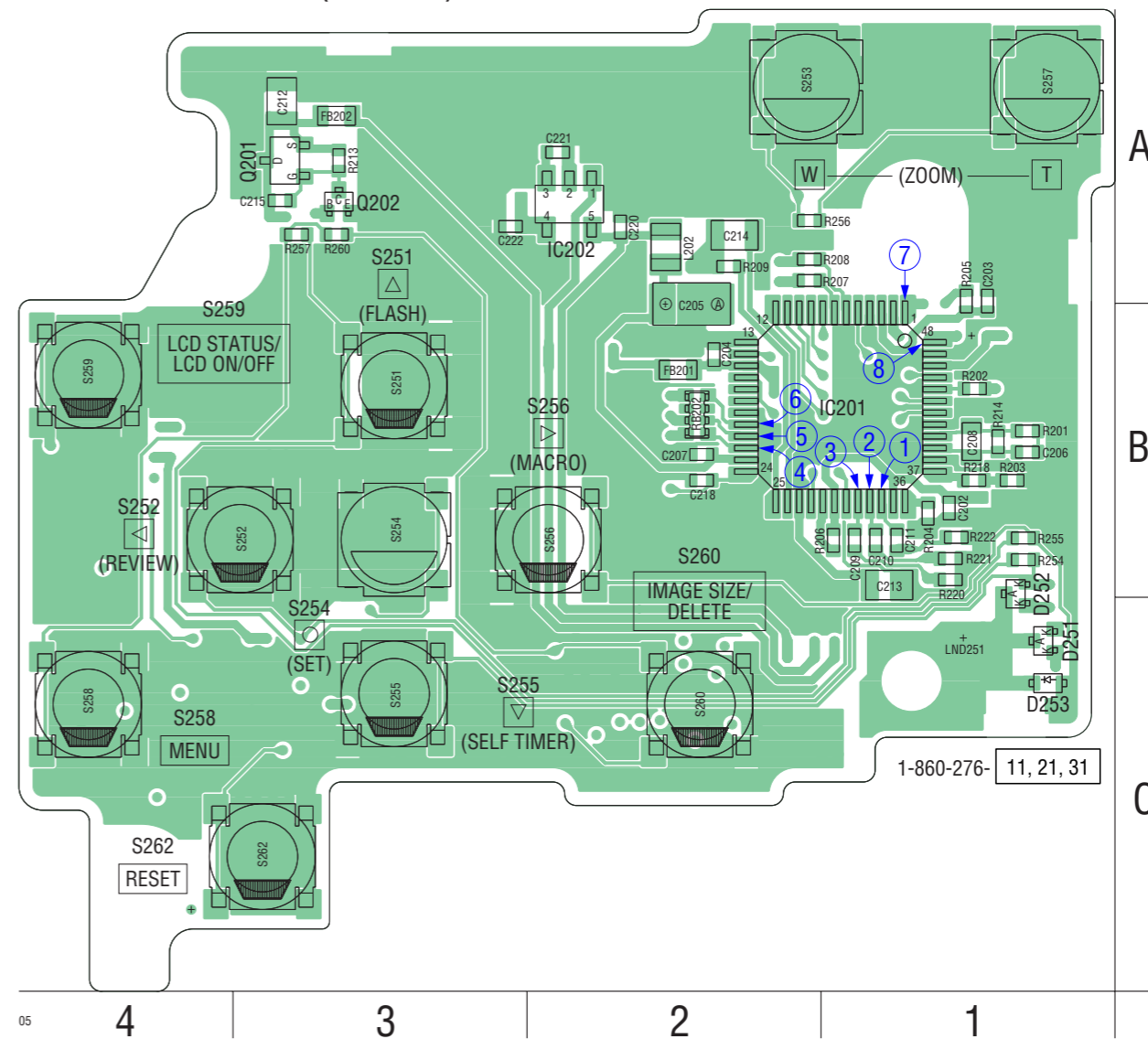

ST-095

Note for Printed Wiring Board (See page 4-35).

 : Uses unleaded solder.

ST-095 BOARD (SIDE A)

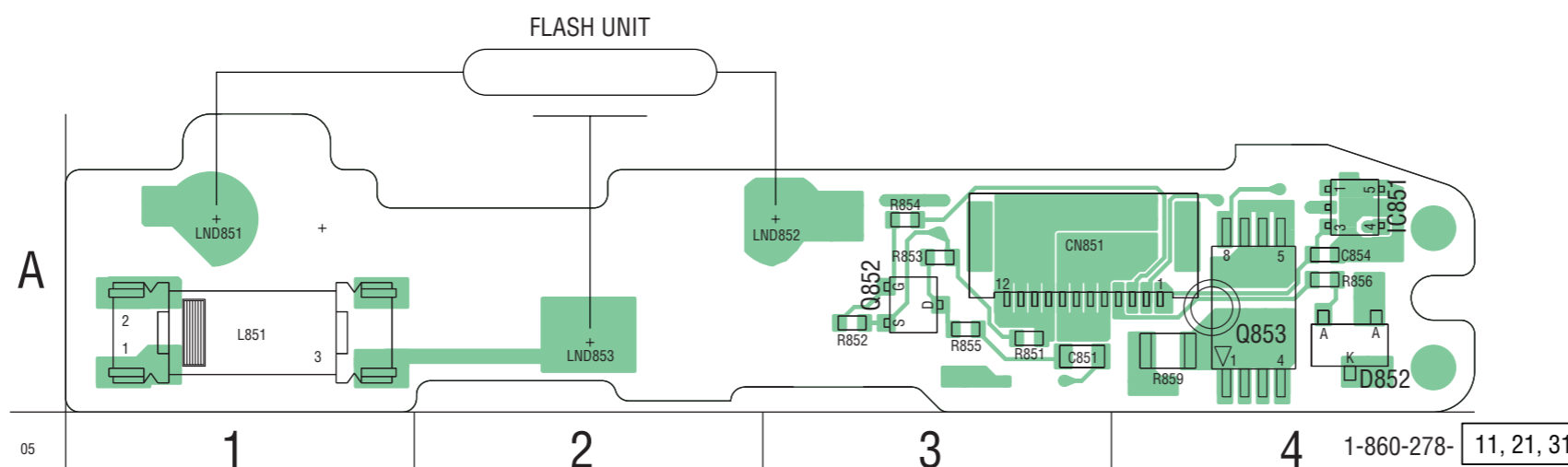

ST-095 BOARD (SIDE B)

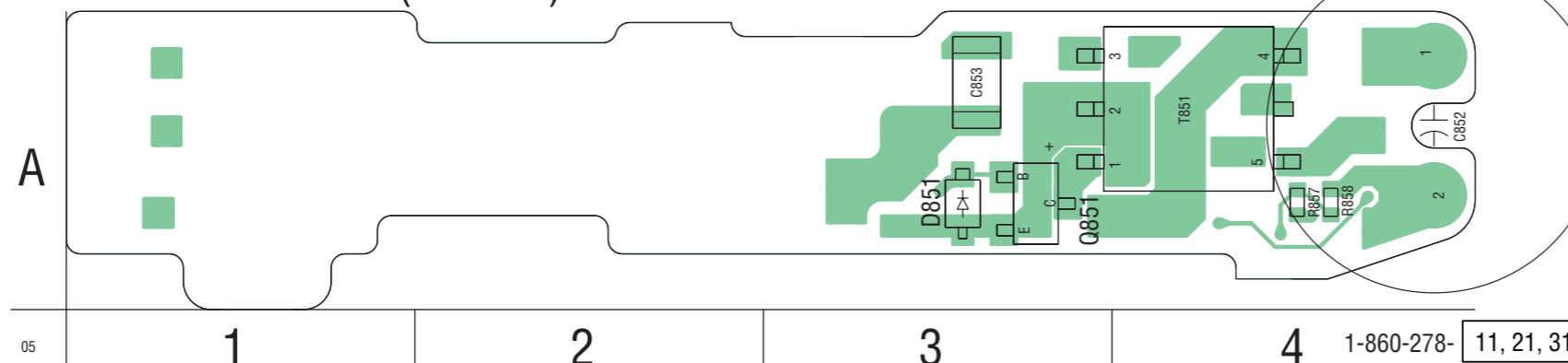

Note: C852 is not included in ST-095 complete board.

MS (FP-861 FLEXIBLE)

Note for Printed Wiring Board (See page 4-35).

 : Uses unleaded solder.

MS BOARD
(FP-861 FLEXIBLE BOARD)

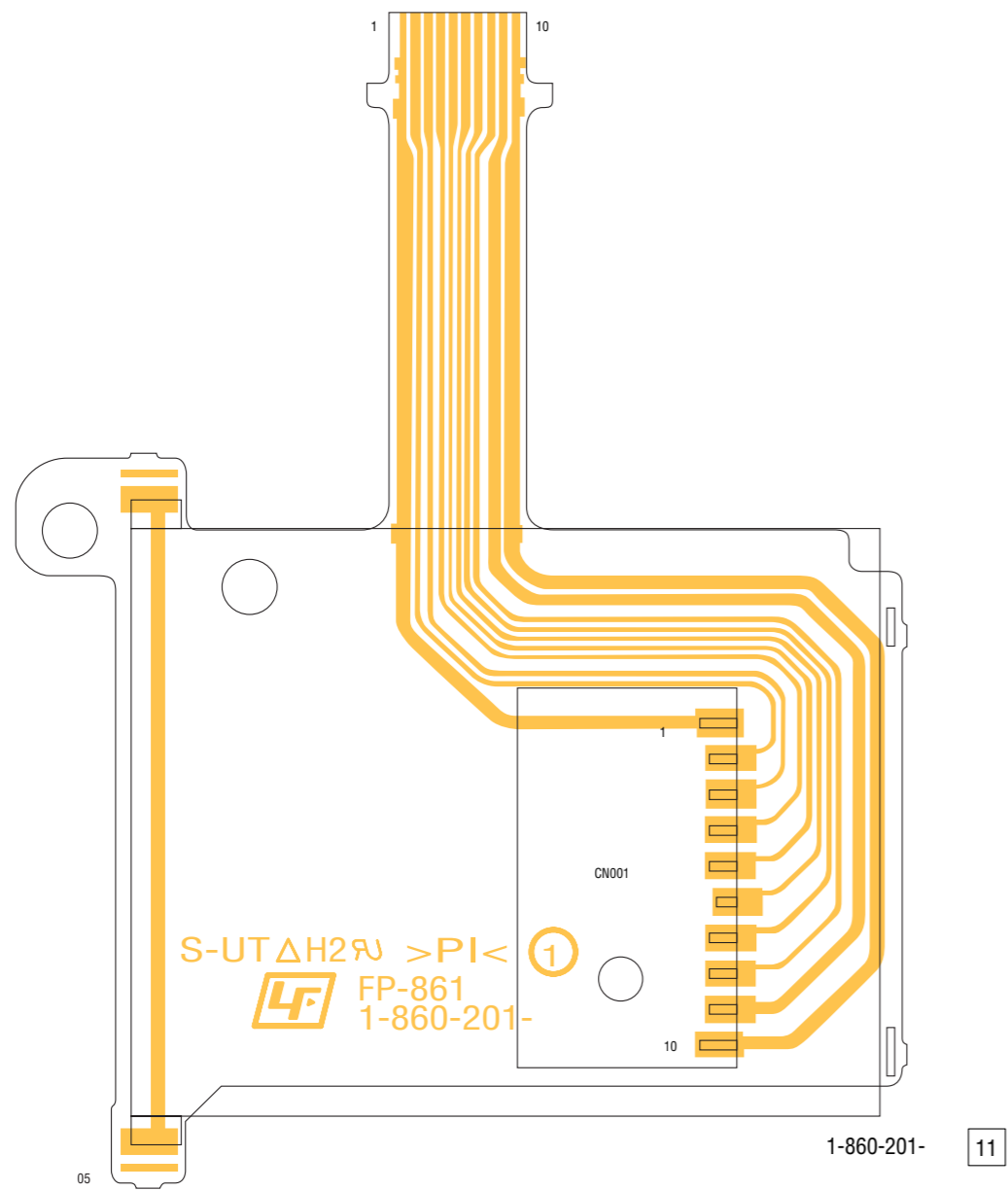

FP-860 FLEXIBLE

Note for Printed Wiring Board (See page 4-35).

 : Uses unleaded solder.

FP-860 FLEXIBLE BOARD

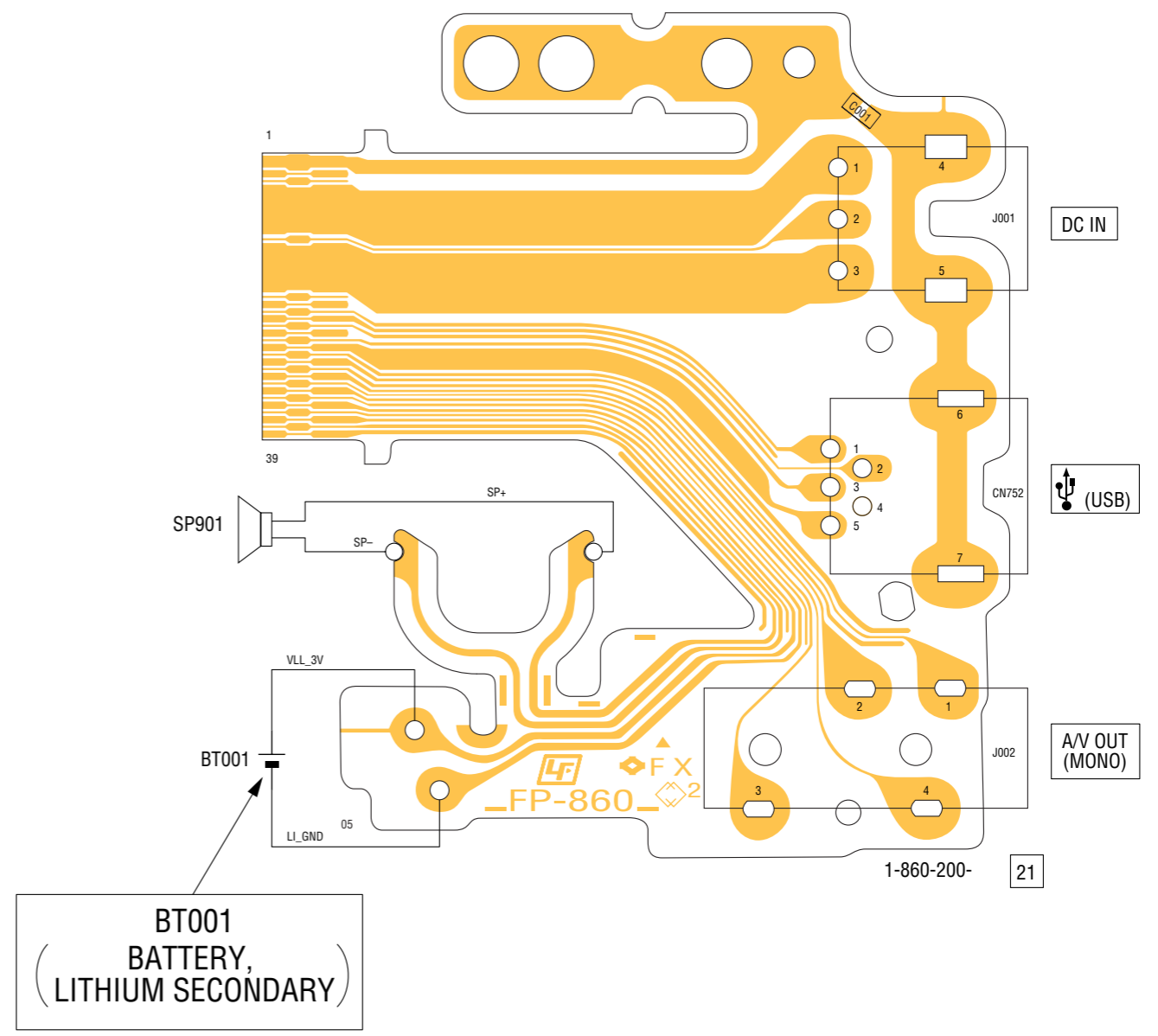

4-3. PRINTED WIRING BOARDS

4-4. MOUNTED PARTS LOCATION

no mark : side A

* mark : side B

CD-498 BOARD

* C801	C-1
C804	B-1
C807	B-1
C808	B-1
* C809	A-2
* C810	A-1
CN801	B-1
* D801	A-1
* D802	A-1
* D803	A-1
* FB801	A-1
FB802	B-1
* Q801	A-2
Q802	B-1
Q803	B-1
* Q804	A-2
Q805	B-1
* R801	A-2
R802	B-1
* R803	A-3
R804	B-1
* R806	A-3
R810	C-2
R811	B-1
R812	B-1
R813	B-1
* R814	A-3
R815	A-1
R816	A-1
R817	A-1

Mounted parts location of the CH-146 and SY-100 boards are not shown.
Page 4-50 is not shown.

4-3. PRINTED WIRING BOARDS

no mark : side A
 * mark : side B

SW-417 BOARD

ST-095 BOARD

* C202	B-1	C851	A-3
* C203	A-1	* C853	A-3
* C205	A-2	C854	A-4
* C206	B-1		
* C207	B-2	CN851	A-3
* C208	B-1		
* C209	B-1	* D851	A-3
* C210	B-1	D852	A-4
* C211	B-1		
* C212	A-3	IC851	A-4
* C213	B-1		
* C214	A-2	L851	A-1
C216	C-4		
C217	C-4	* Q851	A-3
* C218	B-2	Q852	A-3
* C220	A-2	Q853	A-4
* C221	A-2		
* C222	A-3	R851	A-3
		R852	A-3
CN201	C-2	R853	A-3
CN202	C-4	R854	A-3
CN203	B-4	R855	A-3
		R856	A-4
D201	C-3	* R857	A-4
* D251	C-1	* R858	A-4
* D252	C-1	R859	A-4
* FB202	A-3	* T851	A-4
* IC201	B-1		
* IC202	A-2		
* L202	A-2		
* R201	B-1		
* R202	B-1		
* R203	B-1		
* R204	B-1		
* R205	A-1		
* R206	B-1		
* R207	A-1		
* R208	A-1		
* R209	A-2		
R215	C-4		
* R218	B-1		
* R220	B-1		
* R221	B-1		
* R222	B-1		
* R254	B-1		
* R255	B-1		
* R256	A-1		
* R257	A-3		
R258	C-3		
R259	C-3		
* R260	A-3		
R261	C-3		
* RB202	B-2		
* S251	A-3		
* S252	B-4		
* S253	A-2		
* S254	C-3		
* S255	C-3		
* S256	B-2		
* S257	A-1		
* S258	C-4		
* S259	B-4		
* S260	B-2		
* S262	C-4		

NOTE

5. REPAIR PARTS LIST

NOTE: Characters **A** to **Z** of the electrical parts list indicate location of exploded views in which the desired part is shown.

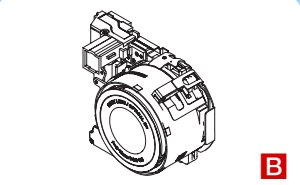
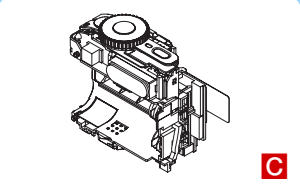
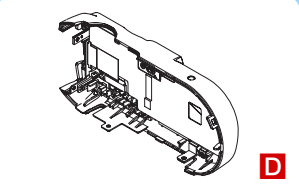
Link	EXPLODED VIEWS			
				
FRONT CABINET BLOCK SECTION	LENS BLOCK SECTION	BT HOLDER BLOCK SECTION	REAR CABINET BLOCK SECTION	

Link	ELECTRICAL PARTS LIST		ACCESSORIES
CD-498 BOARD B	ST-095 BOARD C		
MS BOARD C	SW-417 BOARD D		

5. REPAIR PARTS LIST

SECTION 5 REPAIR PARTS LIST

NOTE:

- -XX, -X mean standardized parts, so they may have some differences from the original one.
- Items marked "*" are not stocked since they are seldom required for routine service. Some delay should be anticipated when ordering these items.
- The mechanical parts with no reference number in the exploded views are not supplied.
- Due to standardization, replacements in the parts list may be different from the parts specified in the diagrams or the components used on the set.
- CAPACITORS:
uF: μ F
- COILS
uH: μ H
- RESISTORS
All resistors are in ohms.
METAL: metal-film resistor
METAL OXIDE: Metal Oxide-film resistor
F: nonflammable
- SEMICONDUCTORS
In each case, u: μ , for example:
uA...: μ A... , uPA... , μ PA... ,
uPB... , μ PB... , μ PC... , μ PC... ,
uPD... , μ PD...
- Abbreviation
AR : Argentine model
AUS : Australian model
BR : Brazilian model
CH : Chinese model
CND : Canadian model
HK : Hong Kong model
JE : Tourist model
KR : Korean model

When indicating parts by reference number, please include the board name.

The components identified by mark \triangle or dotted line with mark \triangle are critical for safety. Replace only with part number specified.

Les composants identifiés par une marque \triangle sont critiques pour la sécurité. Ne les remplacer que par une pièce portant le numéro spécifié.

5. REPAIR PARTS LIST

5-1. EXPLODED VIEWS

5-1-1. FRONT CABINET BLOCK SECTION

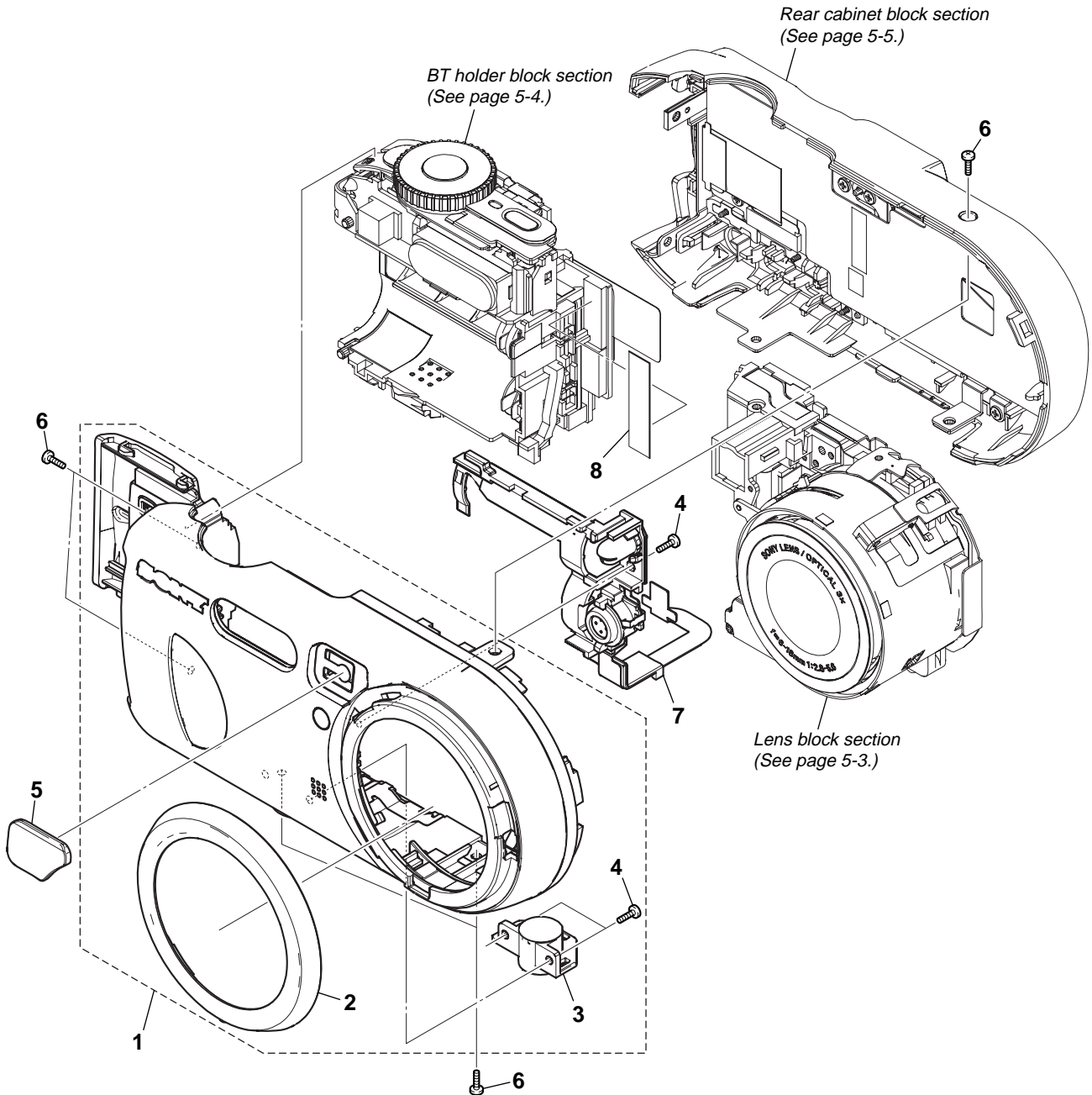

Ref. No.	Part No.	Description	Ref. No.	Part No.	Description
1	X-3954-367-1	CABINET (FRONT) ASSY (530)	5	3-090-799-01	WINDOW (530), OVF
2	3-090-770-01	RING (530), LENS	6	2-025-236-31	SCREW (M1.7)
3	3-080-977-01	TRIPOD	7	1-478-386-11	MIC UNIT (MA-002)
4	3-080-204-21	SCREW, TAPPING, P2	8	3-941-343-21	TAPE (A)

5. REPAIR PARTS LIST

5-1-2. LENS BLOCK SECTION

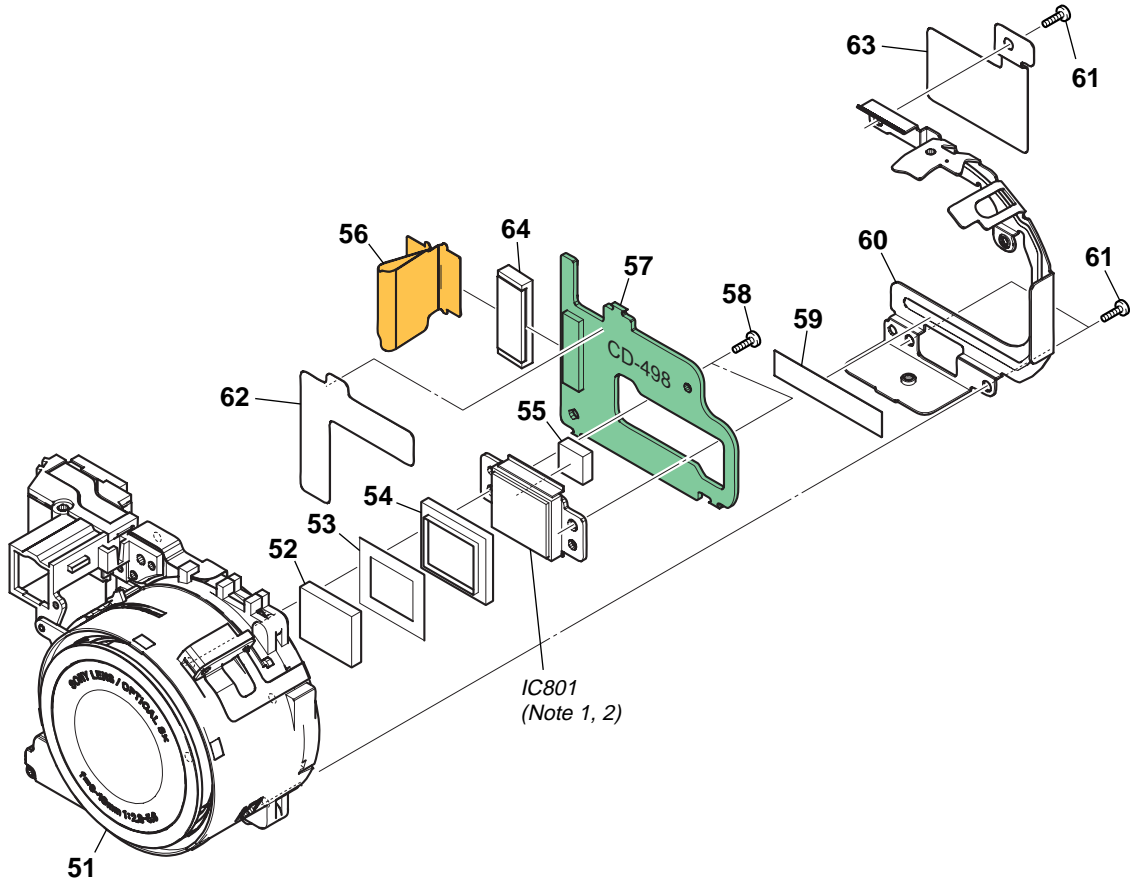

(Note 1) IC801 is not included in CD-498 complete board.

(Note 2) Be sure to read "Precautions for Replacement of CCD Imager" on page 4-8 when changing the CCD imager.

Ref. No.	Part No.	Description
51	1-758-913-21	LENS, VIDEO (CE01C)
52	1-758-915-11	FILTER BLOCK, OPTICAL
53	3-070-143-01	PLATE, LIGHT INTERCEPTION
54	3-054-555-01	RUBBER (K), SEAL
55	3-091-448-01	SHEET (530), CCD RADIATION
56	1-860-194-11	FP-854 FLEXIBLE BOARD
57	A-7113-089-A	CD-498 BOARD, COMPLETE
58	3-080-204-21	SCREW, TAPPING, P2

Ref. No.	Part No.	Description
59	3-091-943-01	SHEET (530), INSULATING, LENS
60	3-090-795-01	FRAME (530), LENS
61	3-078-890-11	SCREW, TAPPING
62	2-050-568-01	SHEET, CD RADIATION
63	2-050-570-01	SHEET, CD COPPER LEAF
64	1-400-769-11	CORE, FERRITE
IC801	A-7016-178-A	CCD BLOCK ASSY (CCD IMAGER) (Note 1, 2)

5. REPAIR PARTS LIST

5-1-3. BT HOLDER BLOCK SECTION

ns: not supplied

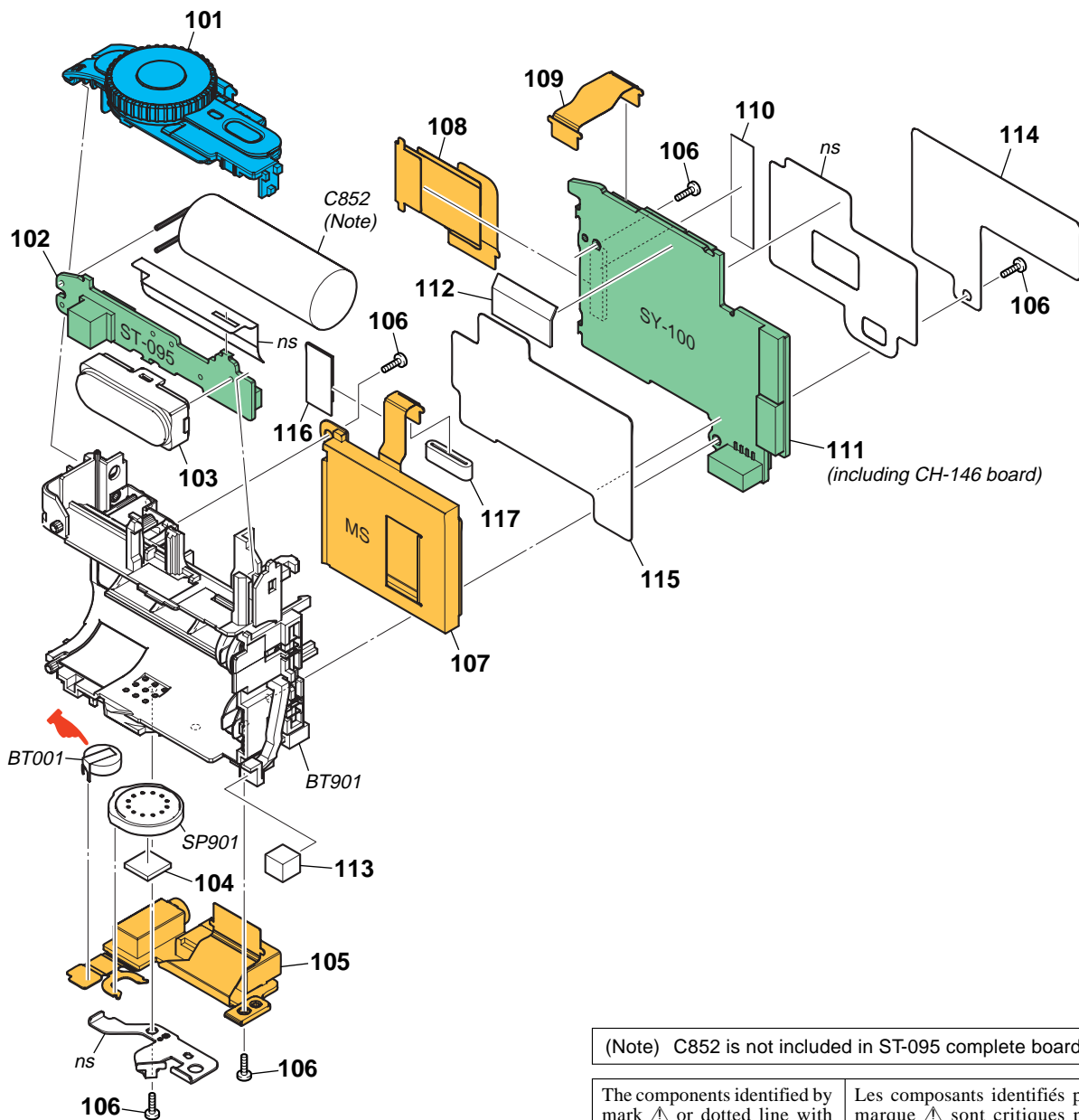

: **BT001 (BATTERY, LITHIUM SECONDARY)**
(Refer to page 4-48.)

(Note) C852 is not included in ST-095 complete board.

The components identified by mark \triangle or dotted line with mark \triangle are critical for safety. Replace only with part number specified.	Les composants identifiés par une marque \triangle sont critiques pour la sécurité. Ne les remplacer que par une pièce portant le numéro spécifié.
--	--

Ref. No.	Part No.	Description
101	1-478-384-11	SWITCH BLOCK, CONTROL
102	A-7113-088-A	ST-095 BOARD, COMPLETE
\triangle 103	1-478-349-11	FLASH UNIT
104	3-090-797-01	CUSHION, SP
105	1-860-200-21	FP-860 FLEXIBLE BOARD
106	3-080-204-21	SCREW, TAPPING, P2
107	A-7113-208-A	MS BOARD, COMPLETE
108	1-860-199-11	FP-859 FLEXIBLE BOARD
109	1-860-192-11	FP-852 FLEXIBLE BOARD
110	3-941-343-21	TAPE (A)
111	A-1059-791-A	SY-100 BOARD, COMPLETE (SERVICE) (including CH-146 board)

Ref. No.	Part No.	Description
112	2-050-462-01	SHEET (530), RL ELECTROSTATIC
113	2-050-219-01	CUSHION, MA RETAINER
114	2-050-569-01	SHEET, SY COPPER LEAF
115	2-050-567-01	SHEET, SY RADIATION
116	2-050-538-01	SHEET, MS RADIATION
117	1-400-770-11	CORE, FERRITE
\triangle BT001	1-528-999-51	BATTERY, LITHIUM SECONDARY
BT901	1-756-421-11	HOLDER, BATTERY (WITH TERMINAL)
\triangle C852	1-100-737-11	CAP, ELECT 135MF (Note)
SP901	1-825-665-11	SPEAKER (1.3CM)

5. REPAIR PARTS LIST

5-1-4. REAR CABINET BLOCK SECTION

ns: not supplied

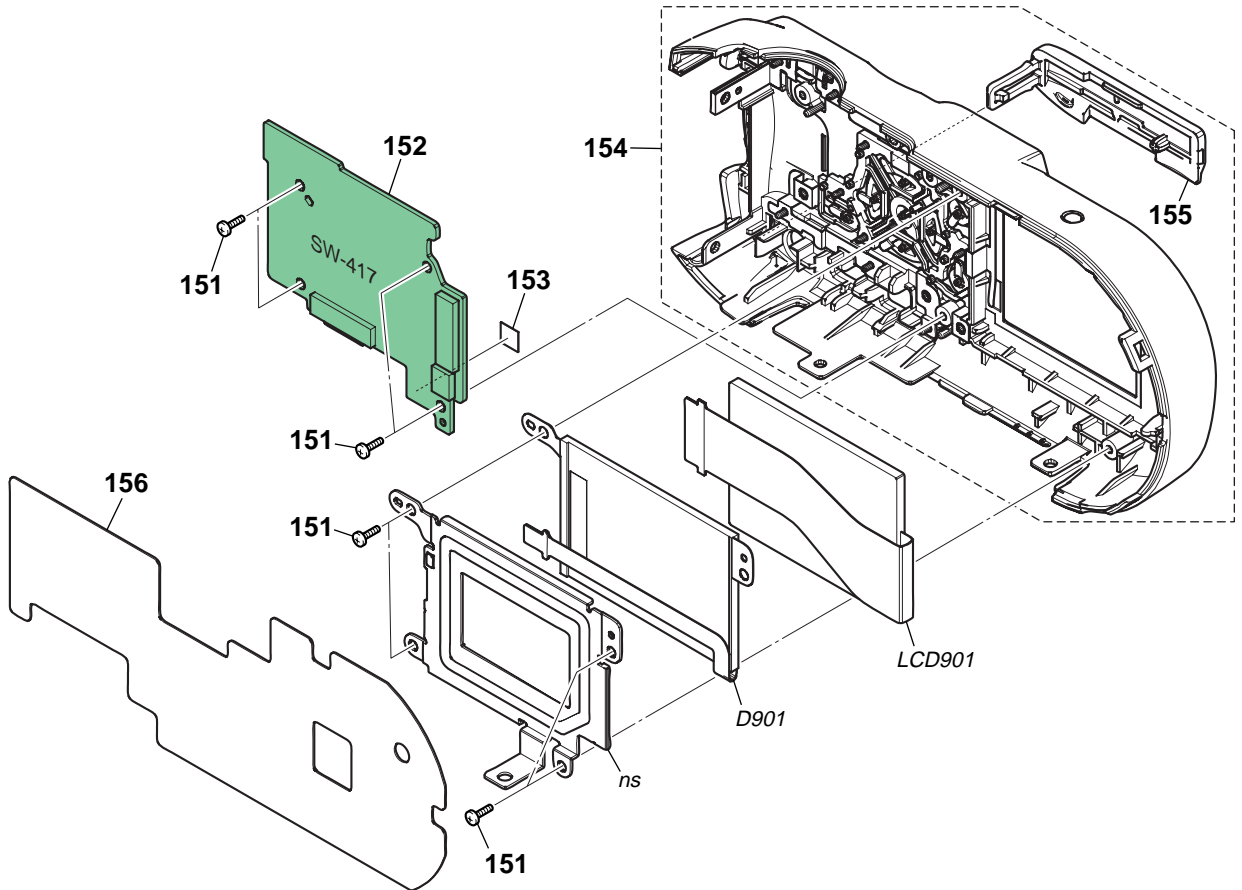

<p>The components identified by mark \triangle or dotted line with mark \triangle are critical for safety. Replace only with part number specified.</p>	<p>Les composants identifiés par une marque \triangle sont critiques pour la sécurité. Ne les remplacer que par une pièce portant le numéro spécifié.</p>
---	--

Ref. No.	Part No.	Description
151	3-078-890-11	SCREW, TAPPING
152	A-7113-087-A	SW-417 BOARD, COMPLETE
153	3-090-794-01	SHEET, RESET
154	X-3954-368-1	CABINET (REAR) ASSY (530)

Ref. No.	Part No.	Description
155	3-090-789-01	COVER, JK
156	2-050-571-01	SHEET, CABINET (REAR RADIATION)
\triangle D901	1-478-464-21	BLOCK, LIGHT GUIDE PLATE (1.5)
LCD901	8-753-205-42	ACX328AK-J

5-2. ELECTRICAL PARTS LIST

Ref. No.	Part No.	Description			
	A-7113-089-A	CD-498 BOARD, COMPLETE			

		(IC801 is not included in this complete board.)			
		< CAPACITOR >			
C801	1-107-826-11	CERAMIC CHIP	0.1uF	10%	16V
C804	1-100-505-11	CERAMIC CHIP	0.1uF	20%	16V
C807	1-107-826-11	CERAMIC CHIP	0.1uF	10%	16V
C808	1-107-826-11	CERAMIC CHIP	0.1uF	10%	16V
C809	1-135-957-91	TANTAL. CHIP	10uF	20%	16V
C810	1-107-826-11	CERAMIC CHIP	0.1uF	10%	16V
		< CONNECTOR >			
CN801	1-817-942-11	CONNECTOR, FPC (ZIF) 39P			
		< DIODE >			
D801	8-719-075-29	DIODE SML-510MWT86S (AE/AF LOCK)			
D802	8-719-077-34	DIODE SML-310YTT86 (FLASH CHARGE)			
D803	8-719-064-07	DIODE SML-310LTT86			
		(SELF TIMER/RECORDING)			
		< FERRITE BEAD >			
FB801	1-414-228-11	INDUCTOR, FERRITE BEAD			
FB802	1-414-228-11	INDUCTOR, FERRITE BEAD			
		< IC >			
IC801	A-7016-178-A	CCD BLOCK ASSY (CCD IMAGER) (Note)			
		< TRANSISTOR >			
Q801	6-550-119-01	TRANSISTOR	DTC144EMT2L		
Q802	6-550-885-01	TRANSISTOR	2SC39320S2S0		
Q803	6-550-119-01	TRANSISTOR	DTC144EMT2L		
Q804	6-550-119-01	TRANSISTOR	DTC144EMT2L		
Q805	6-550-119-01	TRANSISTOR	DTC144EMT2L		
		< RESISTOR >			
R801	1-218-955-11	RES-CHIP	1.5K	5%	1/16W
R802	1-218-990-11	SHORT CHIP	0		
R803	1-218-989-11	RES-CHIP	1M	5%	1/16W
R804	1-218-960-11	RES-CHIP	3.9K	5%	1/16W
R806	1-218-990-11	SHORT CHIP	0		
R810	1-218-960-11	RES-CHIP	3.9K	5%	1/16W
R811	1-216-864-11	SHORT CHIP	0		
R812	1-218-952-11	RES-CHIP	820	5%	1/16W
R813	1-220-198-11	RES-CHIP	20K	5%	1/16W
R814	1-218-981-11	RES-CHIP	220K	5%	1/16W
R815	1-218-952-11	RES-CHIP	820	5%	1/16W
R816	1-218-940-11	RES-CHIP	82	5%	1/16W
R817	1-218-940-11	RES-CHIP	82	5%	1/16W

Electrical parts list of the CH-146 board is not shown.
Pages 5-7 is not shown.

(Note) Be sure to read "Precautions for Replacement of CCD Imager" on page 4-8 when changing the CCD imager.

DSC-P93

MS

ST-095

SW-417

Ref. No.	Part No.	Description
	A-7113-208-A	MS BOARD, COMPLETE *****
		< CONNECTOR >
CN001	1-815-572-61	CONNECTOR, MEMORY STICK
	A-7113-088-A	ST-095 BOARD, COMPLETE ***** (C852 is not included in this complete board.)
		< CAPACITOR >
C851	1-127-715-91	CERAMIC CHIP 0.22uF 10% 16V
△ C852	1-100-737-11	CAP, ELECT 135uF 310V
△ C853	1-100-758-11	CERAMIC CHIP 0.047uF 10% 250V
C854	1-125-777-11	CERAMIC CHIP 0.1uF 10% 10V
		< CONNECTOR >
CN851	1-816-644-31	FFC/FPC CONNECTOR (LIF) 12P
		< DIODE >
△ D851	8-719-073-01	DIODE MA111-(K8) .S0
△ D852	6-500-962-01	DIODE HAU160C030STP
		< IC >
△ IC851	6-703-635-01	IC TND721MH5-S-TL-E
		< COIL >
△ L851	1-456-193-11	COIL, TRIGGER
		< TRANSISTOR >
△ Q851	6-550-759-01	TRANSISTOR CPH3235-S-TL-E
△ Q852	6-550-887-01	TRANSISTOR RTF025N03TL
△ Q853	6-550-656-01	TRANSISTOR CY25BAJ-8F-T23
		< RESISTOR >
R851	1-218-957-11	RES-CHIP 2.2K 5% 1/16W
R852	1-218-977-11	RES-CHIP 100K 5% 1/16W
R853	1-218-956-11	RES-CHIP 1.8K 5% 1/16W
R854	1-218-965-11	RES-CHIP 10K 5% 1/16W
R855	1-218-943-11	RES-CHIP 150 5% 1/16W
R856	1-218-961-11	RES-CHIP 4.7K 5% 1/16W
R857	1-218-937-11	RES-CHIP 47 5% 1/16W
R858	1-218-989-11	RES-CHIP 1M 5% 1/16W
R859	1-216-121-11	RES-CHIP 1M 5% 1/10W
		< TRANSFORMER >
△ T851	1-437-737-11	TRANSFORMER, DC-DC CONVERTER
	A-7113-087-A	SW-417 BOARD, COMPLETE *****
		< CAPACITOR >
C202	1-125-777-11	CERAMIC CHIP 0.1uF 10% 10V
C203	1-164-939-11	CERAMIC CHIP 0.0022uF 10% 50V
C205	1-165-897-11	TANTAL. CHIP 22uF 20% 10V
C206	1-125-777-11	CERAMIC CHIP 0.1uF 10% 10V

Ref. No.	Part No.	Description
C207	1-125-777-11	CERAMIC CHIP 0.1uF 10% 10V
C208	1-164-739-11	CERAMIC CHIP 560PF 5% 50V
C209	1-164-943-11	CERAMIC CHIP 0.01uF 10% 16V
C210	1-164-943-11	CERAMIC CHIP 0.01uF 10% 16V
C211	1-164-943-11	CERAMIC CHIP 0.01uF 10% 16V
C212	1-100-670-11	CERAMIC CHIP 4.7uF 20% 16V
C213	1-127-760-11	CERAMIC CHIP 4.7uF 10% 6.3V
C214	1-127-760-11	CERAMIC CHIP 4.7uF 10% 6.3V
C216	1-107-826-11	CERAMIC CHIP 0.1uF 10% 16V
C217	1-165-908-11	CERAMIC CHIP 1uF 10% 10V
C218	1-125-777-11	CERAMIC CHIP 0.1uF 10% 10V
C220	1-125-777-11	CERAMIC CHIP 0.1uF 10% 10V
C221	1-164-943-11	CERAMIC CHIP 0.01uF 10% 16V
C222	1-100-506-91	CERAMIC CHIP 1uF 20% 6.3V
		< CONNECTOR >
CN201	1-817-942-11	CONNECTOR, FPC (ZIF) 39P
CN202	1-816-654-31	FFC/FPC CONNECTOR (LIF) 6P
CN203	1-816-650-31	FFC/FPC CONNECTOR (LIF) 24P
		< DIODE >
D201	6-500-941-01	DIODE MAZS056008S0
D251	6-500-776-01	DIODE MAZW068H0LS0
D252	6-500-776-01	DIODE MAZW068H0LS0
		< FERRITE BEAD >
FB202	1-414-760-21	BEAD, FERRITE (CHIP) (1608)
		< IC >
IC201	8-752-109-72	IC CXM3006R
IC202	6-704-149-01	IC TK11128CSCL-G
		< COIL >
L202	1-469-846-11	INDUCTOR 47uH
		< RESISTOR >
R201	1-218-975-11	RES-CHIP 68K 5% 1/16W
R202	1-218-949-11	RES-CHIP 470 5% 1/16W
R203	1-208-933-11	METAL CHIP 82K 0.5% 1/16W
R204	1-208-707-11	METAL CHIP 10K 0.5% 1/16W
R205	1-218-953-11	RES-CHIP 1K 5% 1/16W
R206	1-218-977-11	RES-CHIP 100K 5% 1/16W
R207	1-218-990-11	SHORT CHIP 0
R208	1-218-990-11	SHORT CHIP 0
R209	1-218-969-11	RES-CHIP 22K 5% 1/16W
R215	1-218-989-11	RES-CHIP 1M 5% 1/16W
R218	1-208-707-11	METAL CHIP 10K 0.5% 1/16W
R220	1-208-677-11	METAL CHIP 560 0.5% 1/16W
R221	1-208-677-11	METAL CHIP 560 0.5% 1/16W
R222	1-208-677-11	METAL CHIP 560 0.5% 1/16W
R254	1-218-954-11	RES-CHIP 1.2K 5% 1/16W
R255	1-218-954-11	RES-CHIP 1.2K 5% 1/16W
R256	1-218-954-11	RES-CHIP 1.2K 5% 1/16W
R257	1-218-955-11	RES-CHIP 1.5K 5% 1/16W
R258	1-218-955-11	RES-CHIP 1.5K 5% 1/16W
R259	1-218-959-11	RES-CHIP 3.3K 5% 1/16W

The components identified by mark △ or dotted line with mark △ are critical for safety. Replace only with part number specified.

Les composants identifiés par une marque △ sont critiques pour la sécurité. Ne les remplacer que par une pièce portant le numéro spécifié.

Ref. No.	Part No.	Description
R260	1-218-959-11	RES-CHIP 3.3K 5% 1/16W
R261	1-218-953-11	RES-CHIP 1K 5% 1/16W
< NETWORK RESISTOR >		
RB202	1-234-369-21	RES, NETWORK 10 x4 (1005)
< SWITCH >		
S251	1-771-138-82	SWITCH, KEY BOARD (Δ (FLASH))
S252	1-771-138-82	SWITCH, KEY BOARD (◀ (REVIEW))
S253	1-786-157-31	TACTILE SWITCH (ZOOM (W))
S254	1-786-157-31	TACTILE SWITCH (○ (SET))
S255	1-771-138-82	SWITCH, KEY BOARD (∇ (SELF TIMER))
S256	1-771-138-82	SWITCH, KEY BOARD (▷ (MACRO))
S257	1-786-157-31	TACTILE SWITCH (ZOOM (T))
S258	1-771-138-82	SWITCH, KEY BOARD (MENU)
S259	1-771-138-82	SWITCH, KEY BOARD (LCD STATUS / LCD ON/OFF)
S260	1-771-138-82	SWITCH, KEY BOARD (IMAGE SIZE/DELETE)
S262	1-771-138-82	SWITCH, KEY BOARD (RESET)

Electrical parts list of the SY-100 board is not shown.
Pages 5-10 to 5-13 are not shown.

Checking supplied accessories.

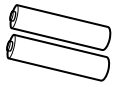

HR6 (size AA) Ni-MH batteries (2)
(not supplied)

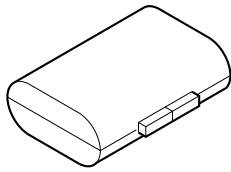

Battery case (1)
3-074-757-01

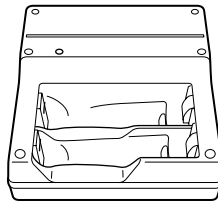

Battery charger (BC-CS2) (1)
△ 1-477-814-12 (US, CND, JE)
△ 1-477-814-22 (AEP, UK, E, HK, AR, AUS)
△ 1-477-814-33 (CH, KR)

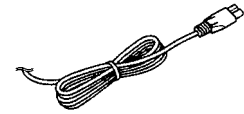

Power cord (1)
△ 1-769-608-11 (AEP, E)
△ 1-776-985-11 (KR)
△ 1-782-476-13 (CH)
△ 1-783-374-11 (UK, HK)
△ 1-783-952-21 (AR)
△ 1-790-107-22 (US, CND)
△ 1-790-732-12 (JE)
△ 1-827-945-11 (AUS)

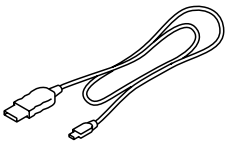

USB cable (1)
1-827-038-11

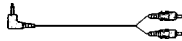

A/V connecting cable (1)
1-824-111-11

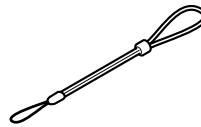

Wrist strap (1)
3-089-555-01

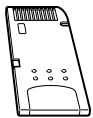

"Memory Stick" (32MB) (1)
(not supplied)

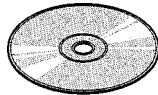

CD-ROM
(SPVD-012 USB driver) (1)
2-022-928-01 (CH)
3-091-338-01 (US, CND)
3-091-339-01 (EXCEPT US, CND, CH)

Other accessories

- 3-091-340-11 MANUAL, INSTRUCTION (ENGLISH)
(US, CND, AEP, UK, E, HK, AUS, CH, JE)
- 3-091-340-21 MANUAL, INSTRUCTION (FRENCH, ITALIAN) (CND, AEP)
- 3-091-340-31 MANUAL, INSTRUCTION (SPANISH, PORTUGUESE)
(AEP, E, AR, JE)
- 3-091-340-41 MANUAL, INSTRUCTION (GERMAN, DUTCH) (AEP)
- 3-091-340-51 MANUAL, INSTRUCTION (TRADITIONAL CHINESE,
SIMPLIFIED CHINESE) (E, CH, HK, JE)
- 3-091-340-61 MANUAL, INSTRUCTION (RUSSIAN, SWEDISH) (AEP)
- 3-091-340-71 MANUAL, INSTRUCTION (ARABIC, PERSIAN) (E)
- 3-091-340-81 MANUAL, INSTRUCTION (KOREAN) (KR, JE)
- 3-091-340-91 MANUAL, INSTRUCTION (POLISH, CZECH) (AEP)
- 3-091-341-11 MANUAL, INSTRUCTION (HUNGARIAN, SLOVAK) (AEP)



Conversion Adaptor (1)
△ 1-569-007-11 (E)
△ 1-573-856-12 (JE)



Conversion Adaptor (1)
△ 1-569-008-12 (E)

The components identified by mark △ or dotted line with mark △ are critical for safety. Replace only with part number specified.

Les composants identifiés par une marque △ sont critiques pour la sécurité. Ne les remplacer que par une pièce portant le numéro spécifié.

[Description of main button functions on toolbar of the Adobe Acrobat Reader Ver5.0 (for Windows)]

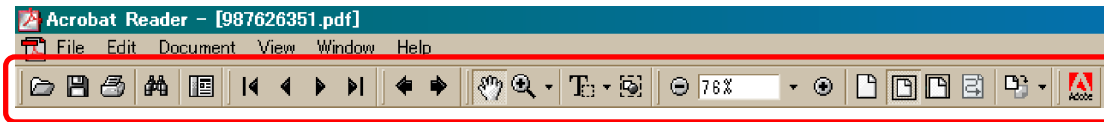

Toolbar



Printing a text

1. Click the Print button .
2. Specify a printer, print range, number of copies, and other options, and then click [OK].

Application of printing:

To set a range to be printed within a page, select the graphic selection tool  and drag on the page to enclose a range to be printed, and then click the Print button.

Reversing the screens displayed once

- To reverse the previous screens (operation) one by one, click the .
- To advance the reversed screens (operation) one by one, click the .

Application to the Service Manual:

This function allows you to go and back between circuit diagram and printed circuit board diagram, and accordingly it will be convenient for the voltage check.

Finding a text

1. Click the Find button .
2. Enter a character string to be found into a text box, and click the [Find]. (Specify the find options as necessary)

Application to the Service Manual:

To execute "find" from current page toward the previous pages, select the check box "Find Backwards" and then click the "Find".

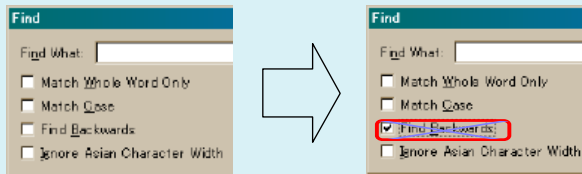





3. Open the find dialog box again, and click the [Find Again] and you can find the matched character strings displayed next. (Character strings entered previously are displayed as they are in the text box.)

Application to the Service Manual:

The parts on the drawing pages (block diagrams, circuit diagrams, printed circuit boards) and parts list pages in a text can be found using this find function. For example, find a Ref. No. of IC on the block diagram, and click the [Find Again] continuously, so that you can move to the Ref. No. of IC on the circuit diagram or printed circuit board diagram successively.

Note: The find function may not be applied to the Service Manual depending on the date of issue.

Moving with link

1. Select either palm tool , zoom tool , text selection tool , or graphic selection tool .
2. Place the pointer in the position in a text where the link exists (such as a button on cover and the table of contents page, or blue characters on the removal flowchart page or drawing page), and the pointer will change to the forefinger form .
3. Then, click the link. (You will go to the link destination.)

Moving with bookmark:

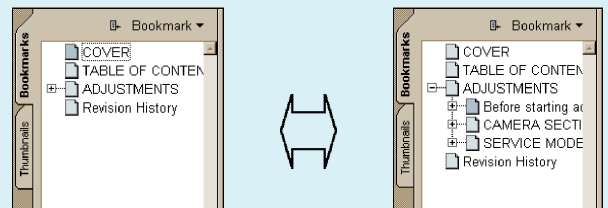

Click an item (text) on the bookmark pallet, and you can move to the link destination. Also, clicking  can display the hidden items.

(To go back to original state, click )



Zooming or rotating the screen display

"Zoom in/out"

- Click the triangle button in the zoom control box to select the display magnification. Or, you may click  or  for zooming in or out.

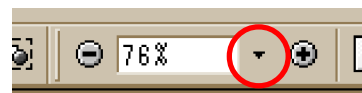





"Rotate"

- Click rotate tool , and the page then rotates 90 degrees each.

Application to the Service Manual:

The printed circuit board diagram you see now can be changed to the same direction as the set.

Switching a page

- To move to the first page, click the .
- To move to the last page, click the .
- To move to the previous page, click the .
- To move to the next page, click the .

Revision History

Ver.	Date	History	Contents	S.M. Rev. issued
1.0	2004.03	Official Release	—	—
1.1	2004.10	Correction-1 (C1)	• Correction of SERVICE NOTE S.M. correction : Page 1-1	Yes