

DSC-P52

SERVICE MANUAL

LEVEL 2

Ver 1.0 2003.03

Revision History



*US Model
Canadian Model
AEP Model
UK Model
E Model
Australian Model
Hong Kong Model
Korea Model
Chinese Model
Tourist Model
Brazilian Model*

Link

SPECIFICATIONS	BLOCK DIAGRAMS	PRINTED WIRING BOARDS
SERVICE NOTE	FRAME SCHEMATIC DIAGRAMS	REPAIR PARTS LIST
DISASSEMBLY	SCHEMATIC DIAGRAMS	

- For INSTRUCTION MANUAL, refer to SERVICE MANUAL, LEVEL 1 (987624841.pdf).
- Reference No. search on printed wiring boards is available.

On the SY-91 board

This service manual provides the information that is premised the circuit board replacement service and not intended repair inside the SY-91 board.

Therefore, schematic diagram, printed wiring board, waveforms, mounted parts location and electrical parts list of the SY-91 board are not shown.

The following pages are not shown.

Schematic diagram Pages 4-7 to 4-26

Printed wiring board Pages 4-39 to 4-42

Waveforms Pages 4-45 to 4-46

Mounted parts location Page 4-48

Electrical parts list Pages 5-7 to 5-13

DIGITAL STILL CAMERA

SONY®



Cyber-shot
Digital Still Camera



SPECIFICATIONS

■ Camera

[System]

Image device	6.67 mm (1/2.7 type) color CCD Primary color filter
Total pixels number of camera	Approx. 3 340 000 pixels
Effective pixels number of camera	Approx. 3 210 000 pixels
Lens	2× zoom lens f=6.3 to 12.6 mm (35 mm camera conversion: 41 to 82 mm (1 5/8 to 3 1/4 inches)) F3.8
Exposure control	Automatic, Program, Twilight, Twilight portrait, Landscape, Snow, Beach
White balance	Automatic, Daylight, Cloudy, Fluorescent, Incandescent
File format (DCF compliant)	Still images: Exif Ver. 2.2, JPEG compliant, GIF (for Clip Motion), DPOF compatible Audio with still image: MPEG1 compliant (Monaural) Movies: MPEG1 compliant (Monaural)
Recording media	"Memory Stick"
Flash	Recommended distance 0.5 to 3.3 m (19 3/4 inches to 10 feet 9 29/32 inches)

[Output connectors]

A/V OUT (MONO) jack (Monaural)	Minijack Video: 1 Vp-p, 75 Ω, unbalanced, sync negative Audio: 327 mV (at a 47 kΩ load) Output impedance 2.2 kΩ
USB jack	mini-B

[LCD screen]

LCD panel used	4.0 cm (1.6 type) TFT drive
Total number of dots	61 600 (280×220) dots

[Power, general]

Power	AA nickel hydride batteries (2) 2.4 V AC-LS5 AC Adaptor (not supplied), 4.2 V
Power consumption (when recording)	1.6W
Operating temperature range	0° to +40°C (32° to +104°F)
Storage temperature range	-20° to +60°C (-4° to +140°F)
Dimensions	123.2 × 57.7 × 52 mm (4 7/8 × 2 3/8 × 2 1/8 inches)
Mass	Approx. 280 g (9.9 oz) (two batteries, "Memory Stick" and wrist strap included)
Microphone	Electret condenser microphone
Speaker	Dynamic speaker

■ BC-CS2A/CS2B Ni-MH battery charger

Power requirements	AC 100 to 240V 50/60Hz 3 W
Output voltage	AA : DC 1.4 V 400 mA × 2 AAA : DC 1.4 V 160 mA × 2
Operating temperature range	0° to +40°C (32° to +104°F)
Dimensions	71 × 30 × 91 mm (2 7/8 × 1 3/16 × 3 5/8 inches) (W/H/D)
Mass	Approx. 90 g (3 oz)

■ AC-LS5 AC Adaptor (not supplied)

Power requirements	AC 100 to 240 V, 50/60 Hz 11 W 0.16 to 0.09 A
Rated output voltage	DC 4.2 V, 1.5 A
Operating temperature range	0° to +40°C (32° to +104°F)
Storage temperature range	-20° to +60°C (-4° to +140°F)
Dimensions	48 × 29 × 81 mm (1 15/16 × 1 3/16 × 3 1/4 inches) (W/H/D, protruding parts not included)
Mass	Approx. 180 g (6 oz) (adaptor only)

Accessories

HR6 (size AA) Ni-MH batteries (2)
Battery case
BC-CS2A/CS2B Ni-MH Battery charger (1)
Power cord (mains lead) (1)
USB cable (1)
A/V connecting cable (1)
Wrist strap (1)
"Memory Stick" (16MB) (1)
CD-ROM (USB driver: SPVD-010) (1)
Operating Instructions (1)

Design and specifications are subject to change without notice.

CAUTION :

Danger of explosion if battery is incorrectly replaced. Replace only with the same or equivalent type.

SAFETY-RELATED COMPONENT WARNING!!

COMPONENTS IDENTIFIED BY MARK \triangle OR DOTTED LINE WITH MARK \triangle ON THE SCHEMATIC DIAGRAMS AND IN THE PARTS LIST ARE CRITICAL TO SAFE OPERATION. REPLACE THESE COMPONENTS WITH SONY PARTS WHOSE PART NUMBERS APPEAR AS SHOWN IN THIS MANUAL OR IN SUPPLEMENTS PUBLISHED BY SONY.

ATTENTION AU COMPOSANT AYANT RAPPORT À LA SÉCURITÉ!

LES COMPOSANTS IDENTIFIÉS PAR UNE MARQUE \triangle SUR LES DIAGRAMMES SCHÉMATIQUES ET LA LISTE DES PIÈCES SONT CRITIQUES POUR LA SÉCURITÉ DE FONCTIONNEMENT. NE REMPLACER CES COMPOSANTS QUE PAR DES PIÈCES SONY DONT LES NUMÉROS SONT DONNÉS DANS CE MANUEL OU DANS LES SUPPLÉMENTS PUBLIÉS PAR SONY.

SAFETY CHECK-OUT

After correcting the original service problem, perform the following safety checks before releasing the set to the customer.

1. Check the area of your repair for unsoldered or poorly-soldered connections. Check the entire board surface for solder splashes and bridges.
2. Check the interboard wiring to ensure that no wires are "pinched" or contact high-wattage resistors.
3. Look for unauthorized replacement parts, particularly transistors, that were installed during a previous repair. Point them out to the customer and recommend their replacement.
4. Look for parts which, through functioning, show obvious signs of deterioration. Point them out to the customer and recommend their replacement.
5. Check the B+ voltage to see it is at the values specified.
6. Flexible Circuit Board Repairing
 - Keep the temperature of the soldering iron around 270°C during repairing.
 - Do not touch the soldering iron on the same conductor of the circuit board (within 3 times).
 - Be careful not to apply force on the conductor when soldering or unsoldering.

Unleaded solder

Boards requiring use of unleaded solder are printed with the lead-free mark (LF) indicating the solder contains no lead.

(Caution: Some printed circuit boards may not come printed with the lead free mark due to their particular size.)



: LEAD FREE MARK

Unleaded solder has the following characteristics.

- Unleaded solder melts at a temperature about 40°C higher than ordinary solder.
Ordinary soldering irons can be used but the iron tip has to be applied to the solder joint for a slightly longer time.
Soldering irons using a temperature regulator should be set to about 350°C.
Caution: The printed pattern (copper foil) may peel away if the heated tip is applied for too long, so be careful!
- Strong viscosity
Unleaded solder is more viscous (sticky, less prone to flow) than ordinary solder so use caution not to let solder bridges occur such as on IC pins, etc.
- Usable with ordinary solder
It is best to use only unleaded solder but unleaded solder may also be added to ordinary solder.

TABLE OF CONTENTS

1. SERVICE NOTE	1-1	4-5. MOUNTED PARTS LOCATION	4-47
2. DISASSEMBLY			
2-1. CABINET (REAR) BLOCK ASSEMBLY	2-2		
2-2. BLOCK LIGHT GUIDE PLATE, LCD MODULE, CONTROL SWITCH BLOCK (SW-392), LITHIUM BATTERY	2-3		
2-3. MAIN BLOCK ASSEMBLY	2-4		
2-4. UNIT PARTS (UA-003), DC 8C-028G MOTOR	2-4		
2-5. OPTICAL FINDER (B148B), VIDEO LENS (B147A), CCD BLOCK ASSEMBLY	2-5		
2-6. CONTROL SWITCH BLOCK (RL-060), ST-82 BOARD	2-5		
2-7. MEMORY STICK CONNECTOR, JK-BLOCK (JK-256)	2-6		
2-8. SY-91 BOARD	2-7		
2-9. OPTICAL FINDER (B148B), VIDEO LENS (B147A) ...	2-9		
2-10. FLASH UNIT	2-9		
2-11. CIRCUIT BOARDS LOCATION	2-10		
2-12. FLEXIBLE BOARDS LOCATION	2-11		
HELP (List of caution points is shown here)			

Mounted parts location of the SY-91 board is not shown.
Page 4-48 is not shown.

3. BLOCK DIAGRAMS

3-1. OVERALL BLOCK DIAGRAM	3-1
3-2. CAMERA BLOCK DIAGRAM	3-3
3-3. FRONT/LCD BLOCK DIAGRAM	3-5
3-4. POWER BLOCK DIAGRAM	3-7

4. PRINTED WIRING BOARDS AND SCHEMATIC DIAGRAMS

4-1. FRAME SCHEMATIC DIAGRAM (1/2)	4-1
FRAME SCHEMATIC DIAGRAM (2/2)	4-3
4-2. SCHEMATIC DIAGRAMS	

Schematic diagram of the SY-91 board are not shown.
Pages from 4-7 to 4-26 are not shown.

- ST-82 (FLASH DRIVE)/FP-643 FLEXIBLE SCHEMATIC DIAGRAM
- JK BLOCK (JK-256) (JACK) SCHEMATIC DIAGRAM
- CONTROL SWITCH BLOCK (SW-392) (LCD, CONTROL SW) SCHEMATIC DIAGRAM
- RL-060 (POWER/SHUTTER SW) SCHEMATIC DIAGRAM
- UA-003 (AF LED, SW) SCHEMATIC DIAGRAM

4-3. PRINTED WIRING BOARDS	
• ST-82 (FLASH DRIVE) PRINTED WIRING BOARD	4-37

Printed wiring board of the SY-91 board are not shown.
Pages from 4-39 to 4-42 are not shown.

- JK BLOCK (JK-256) (JACK) FLEXIBLE BOARD

4-4. WAVEFORMS	4-45
----------------------	------

Waveforms of the SY-91 board are not shown.
Pages 4-45 to 4-46 are not shown.

5. REPAIR PARTS LIST	
5-1. EXPLODED VIEWS	5-1
5-1-1. CABINET (FRONT) SECTION	5-3
5-1-2. CABINET (REAR) BLOCK SECTION	5-4
5-1-3. MAIN BLOCK SECTION-1	5-5
5-1-4. MAIN BLOCK SECTION-2	5-6
5-2. ELECTRICAL PARTS LIST	5-14

Parts list of the SY-91 board are not shown.
Pages from 5-7 to 5-13 are not shown.



SECTION 1 SERVICE NOTE

• NOTE FOR REPAIR

Make sure that the flat cable and flexible board are not cracked or bent at the terminal.
Do not insert the cable insufficiently nor crookedly.

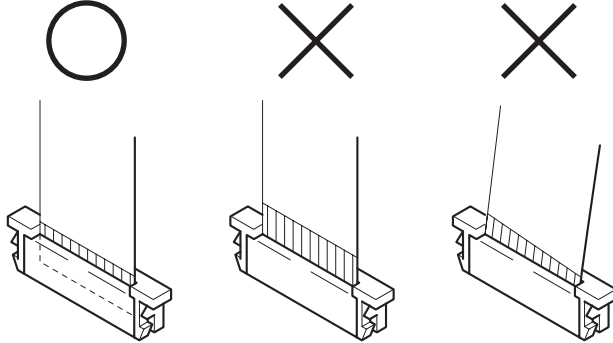

Cut and remove the part of gilt which comes off at the point.
(Take care that there are some pieces of gilt left inside)

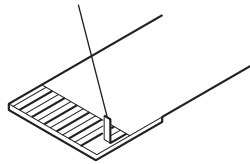

When remove a connector, don't pull at wire of connector.
Be in danger of the snapping of a wire.

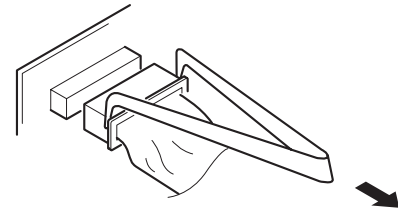

When installing a connector, don't press down at wire of connector.
Be in danger of the snapping of a wire.

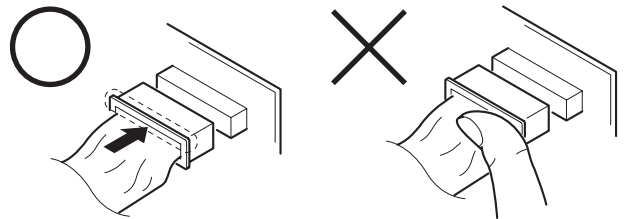

[Discharging of the FLASH unit's charging capacitor]

The charging capacitor of the FLASH unit is charged up to the maximum 300 V potential.

There is a danger of electric shock by this high voltage when the capacitor is handled by hand. The electric shock is caused by the charged voltage which is kept without discharging when the main power of the DSC-P52 is simply turned off. Therefore, the remaining voltage must be discharged as described below.

Preparing the Short Jig

To preparing the short jig, a small clip is attached to each end of a resistor of 1 k Ω / 1 W (1-215-869-11)

Wrap insulating tape fully around the leads of the resistor to prevent electrical shock.

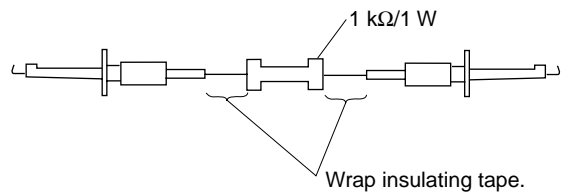

Discharging the Capacitor

Short circuits between the positive and the negative terminals of charged capacitor with the short jig about 10 seconds.

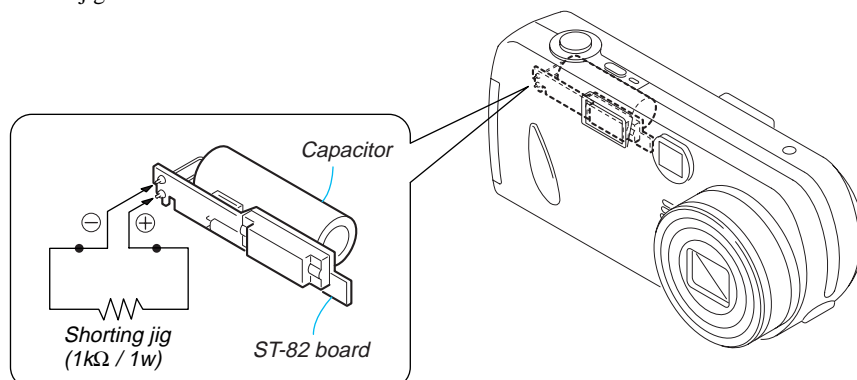

[Description on Self-diagnosis Display]

Self-diagnosis display

The camera has a self-diagnosis display. This function displays the camera condition with five-digits (a combination of a letter and figures) on the LCD screen. If this occurs check the following code chart. The five-digits display informs you of the camera's current condition. The last two digits (indicated by □□) will differ depending on the state of the camera.

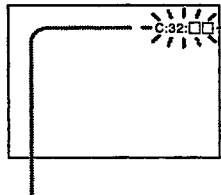

Self-diagnosis display

- C: □□: □□
The contents which can be handled by customer, are displayed.
- E: □□: □□
The contents which can be handled by engineer, are displayed.

Display Code	Countermeasure	Cause	Caution Display During Error
C:32:01	Turn off the main power then back on.	Trouble with hardware.	SYSTEM ERROR
C:13:01	Replace the memory stick. Format the memory stick with the DSC-P52.	<ul style="list-style-type: none"> • The type of memory stick that cannot be used by this machine, is inserted. • Data is damaged. • Unformatted memory stick is inserted. 	MS ERROR
E:91:01	Checking of flash unit or replacement of flash unit.	Abnormality when flash is being charged.	Flash LED Flash display Flashing at 3.2 Hz
E:61:00 *1	Checking of lens drive circuit	When failed in the focus initialization.	—
E61:10 *1			

Note : The error code is cleared if the battery is removed, except defective flash unit.
*1: The error display is given in two ways.



SECTION 2 DISASSEMBLY



The following flow chart shows the disassembly procedure.

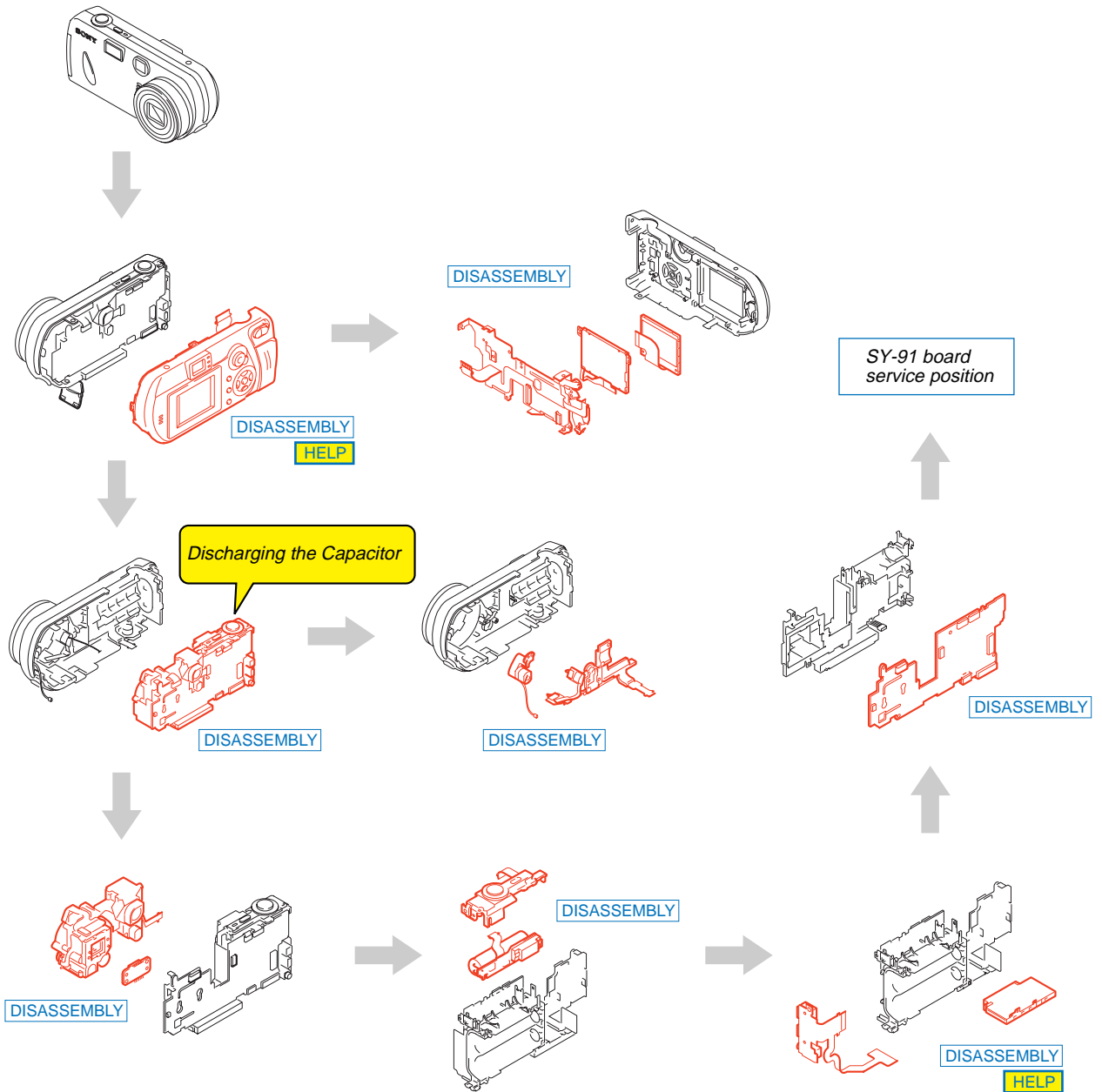

PROCEDURE OF REMOVING THE SY-91 BOARD (SERVICE POSITION)

- ① 2-1. CABINET (REAR) BLOCK ASSEMBLY (page 2-2)
- ② 2-2. BLOCK LIGHT GUIDE PLATE, LCD MODULE, (page 2-3)
CONTROL SWITCH BLOCK (SW-392), LITHIUM BATTERY
- ③ 2-3. MAIN BLOCK ASSEMBLY (page 2-4)
- ④ 2-4. UNIT PARTS (UA-003), DC 8C-028G MOTOR (page 2-4)
- ⑤ 2-5. OPTICAL FINDER (B148B), VIDEO LENS (B147A), CCD BLOCK ASSEMBLY (page 2-5)
- ⑥ 2-6. CONTROL SWITCH BLOCK (RL-060), ST-82 BOARD (page 2-5)
- ⑦ 2-7. MEMORY STICK CONNECTOR, JK BLOCK (JK-256) (page 2-6)
- ⑧ 2-8. SY-91 BOARD (page 2-7)

NOTE: Follow the disassembly procedure in the numerical order given.

2-1. CABINET (REAR) BLOCK ASSEMBLY

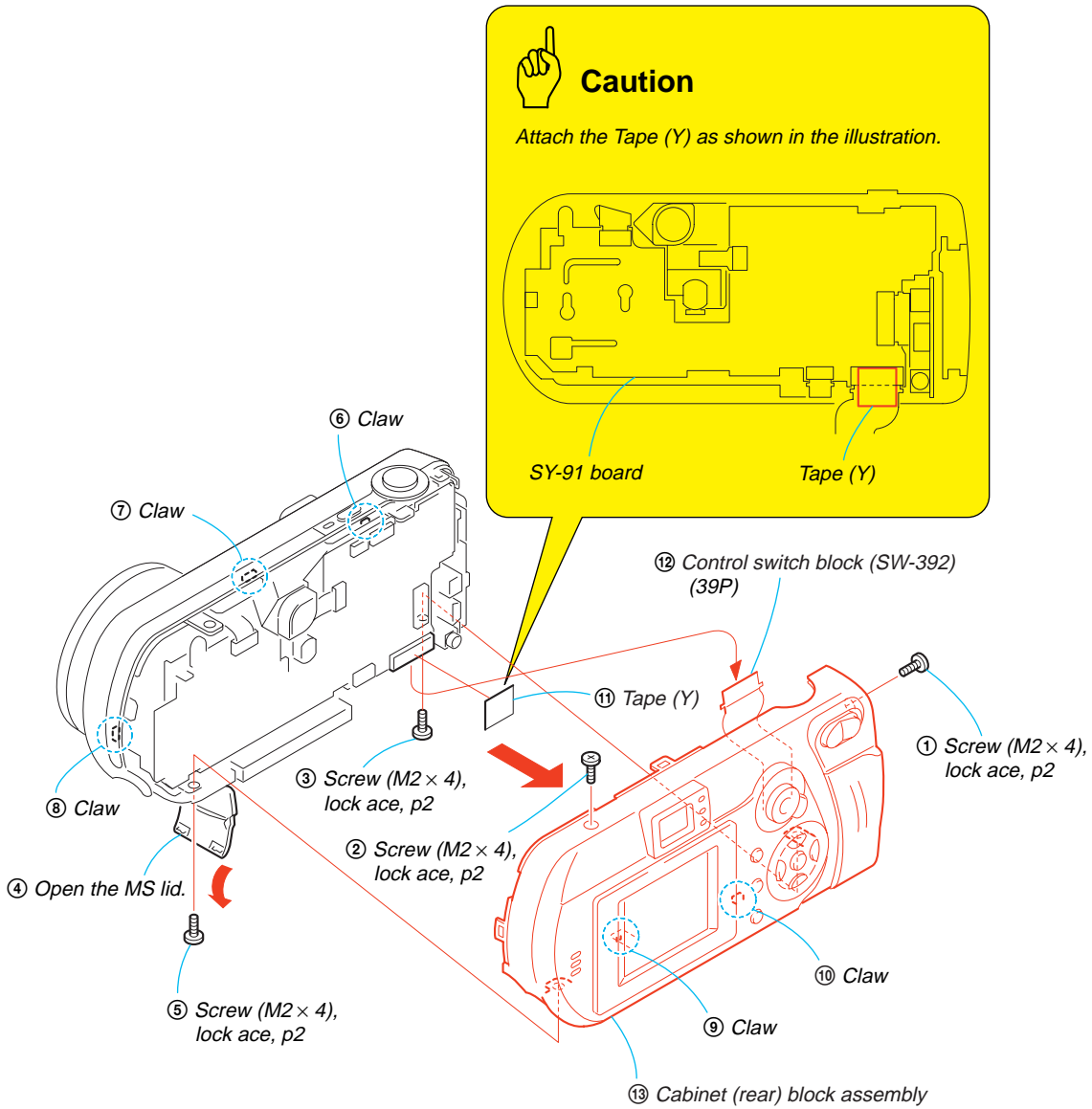

2-2. BLOCK LIGHT GUIDE PLATE, LCD MODULE, CONTROL SWITCH BLOCK (SW-392), LITHIUM BATTERY

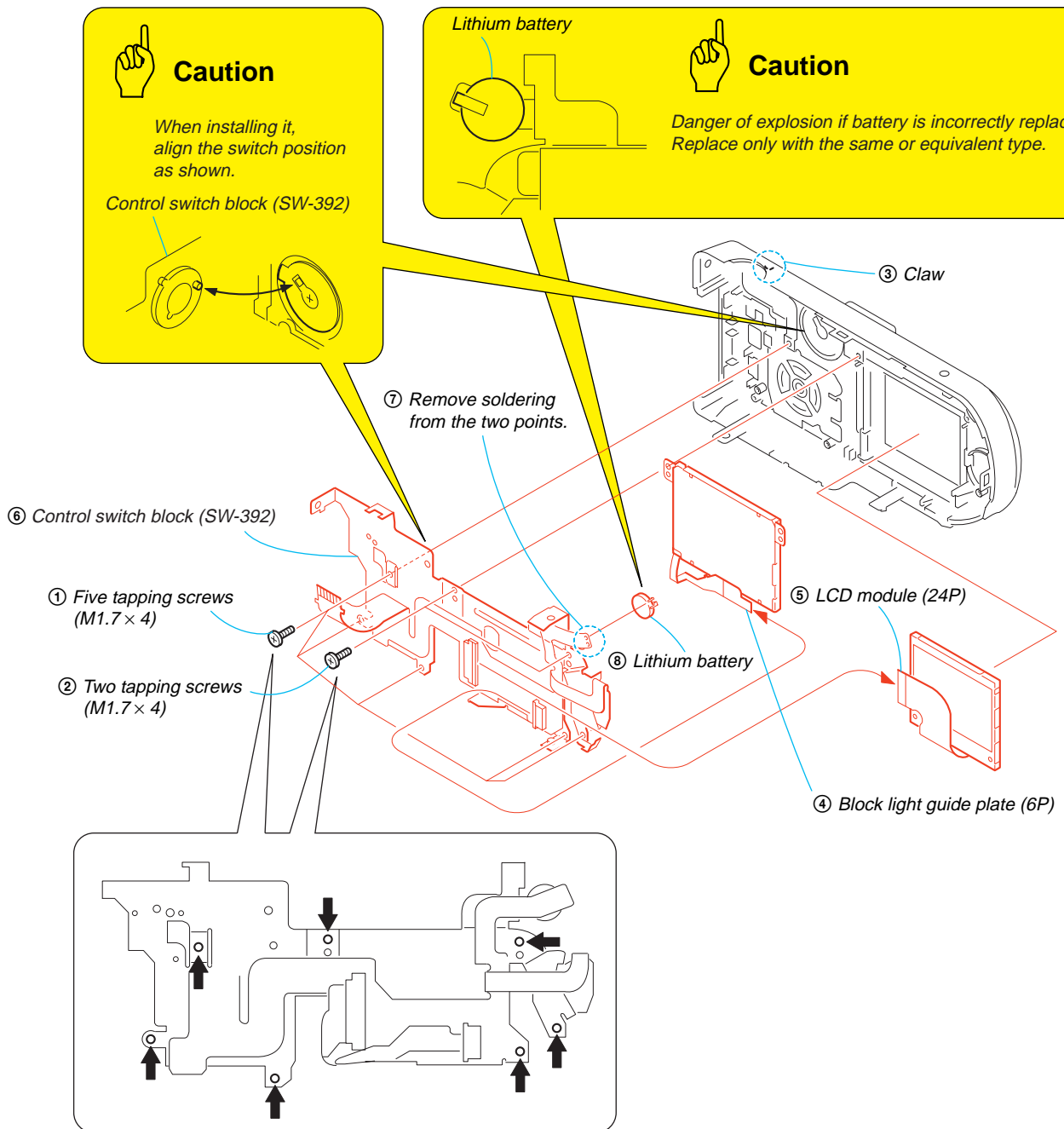

2-3. MAIN BLOCK ASSEMBLY

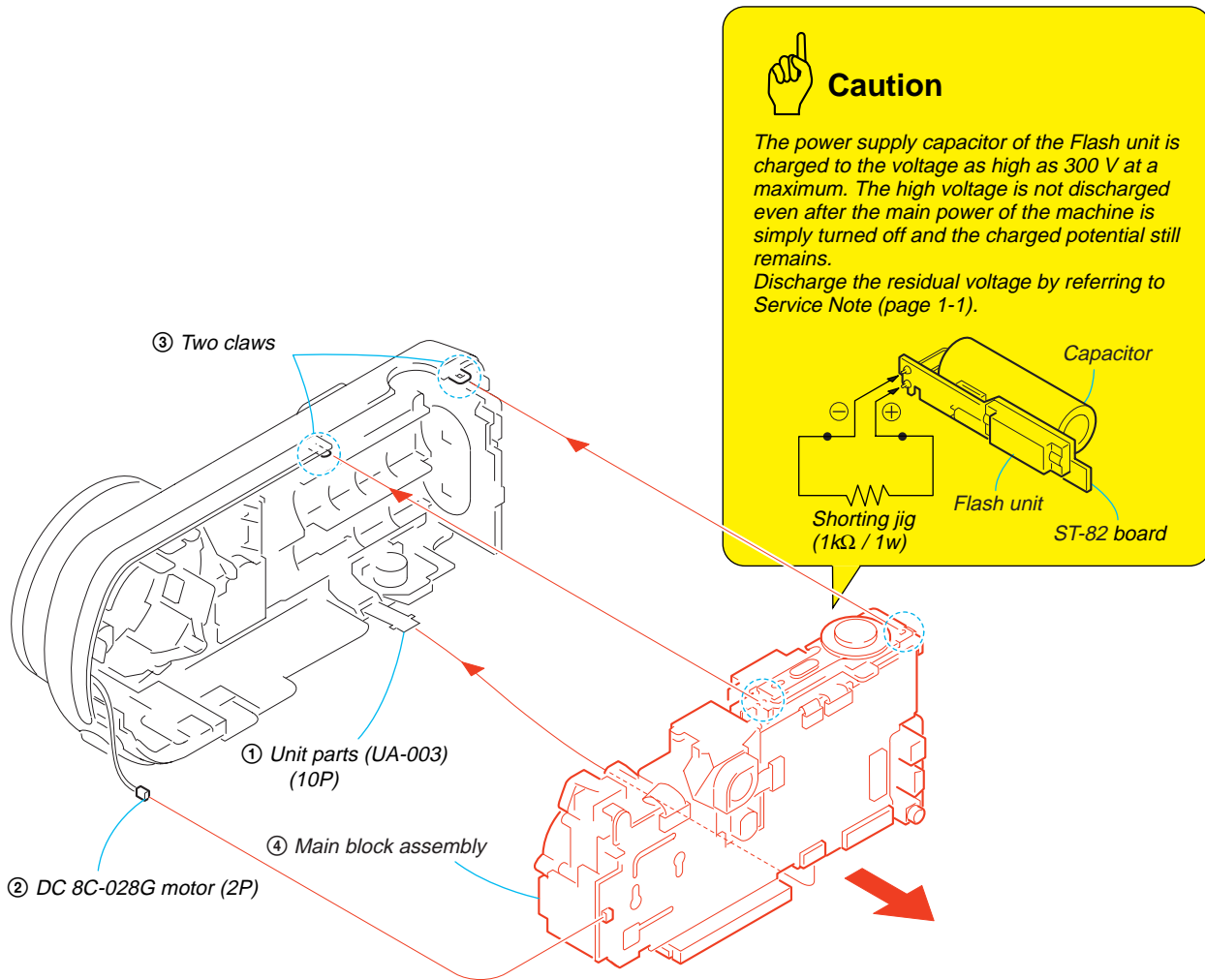

2-4. UNIT PARTS (UA-003), DC 8C-028G MOTOR

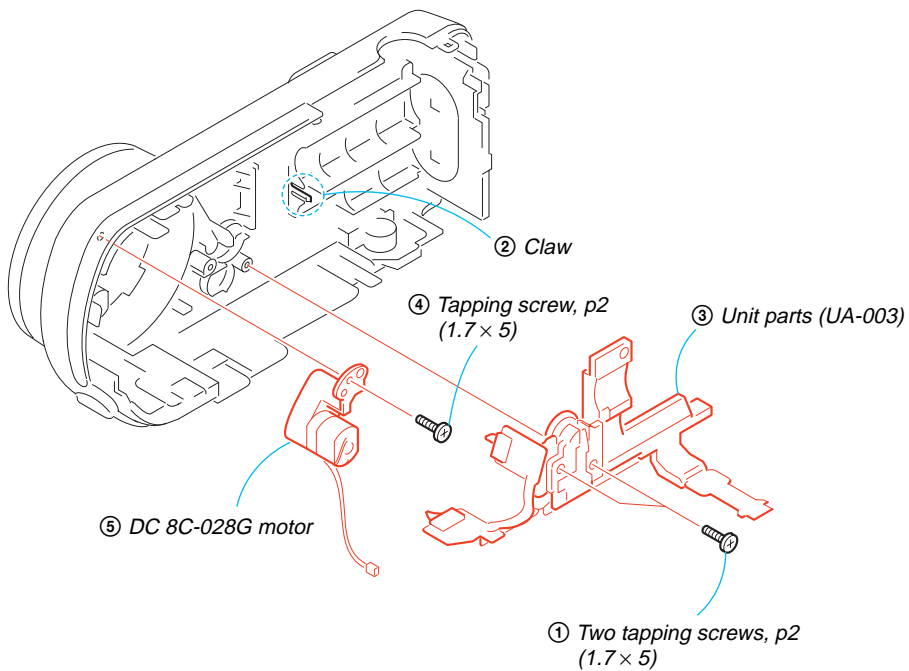

2-5. OPTICAL FINDER (B148B), VIDEO LENS (B147A), CCD BLOCK ASSEMBLY

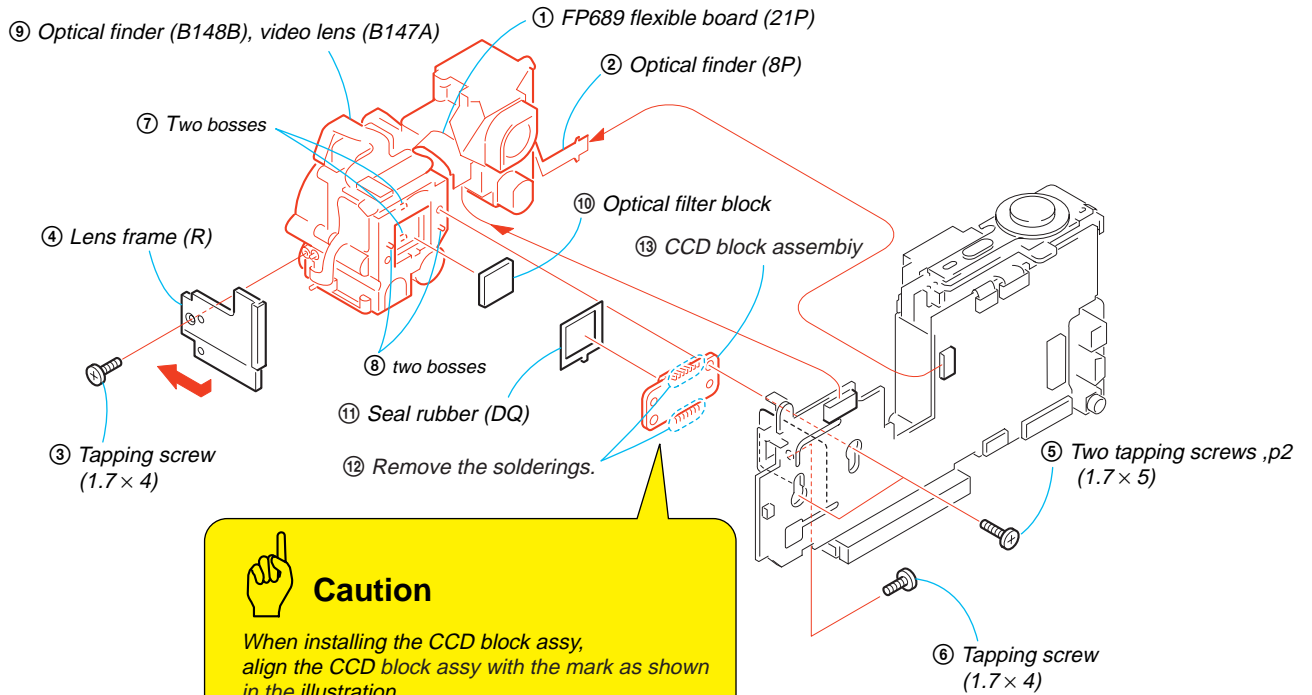

Caution

When installing the CCD block assy, align the CCD block assy with the mark as shown in the illustration.

mark
mark

2-6. CONTROL SWITCH BLOCK (RL-060), ST-82 BOARD

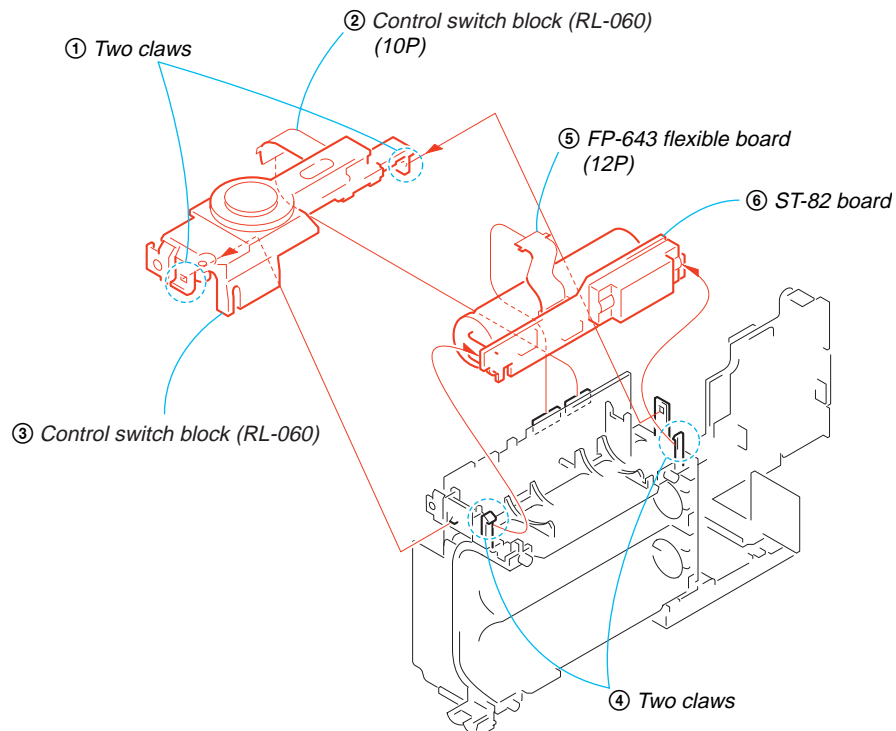

2-7. MEMORY STICK CONNECTOR, JK BLOCK (JK-256)

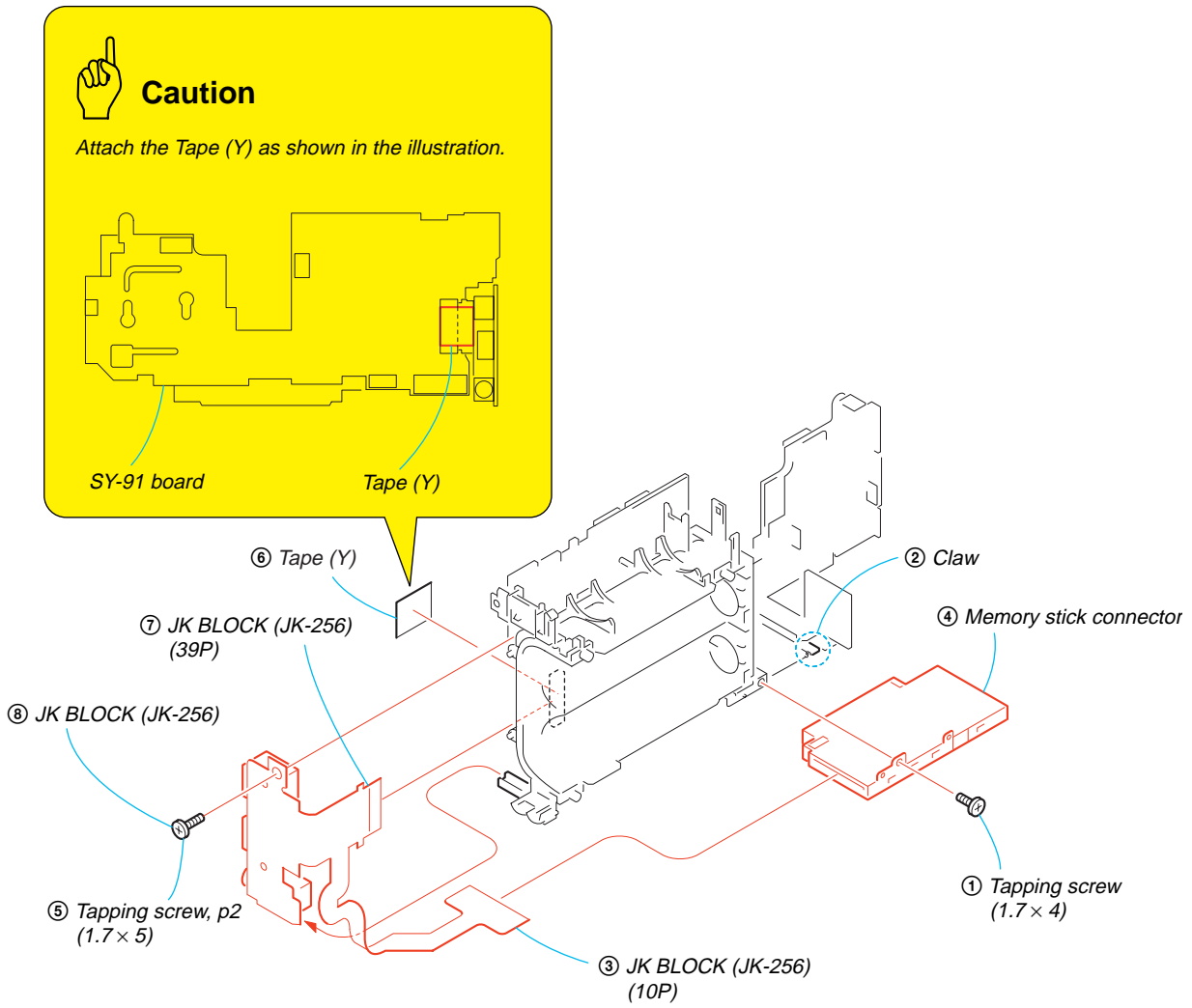

2-8. SY-91 BOARD

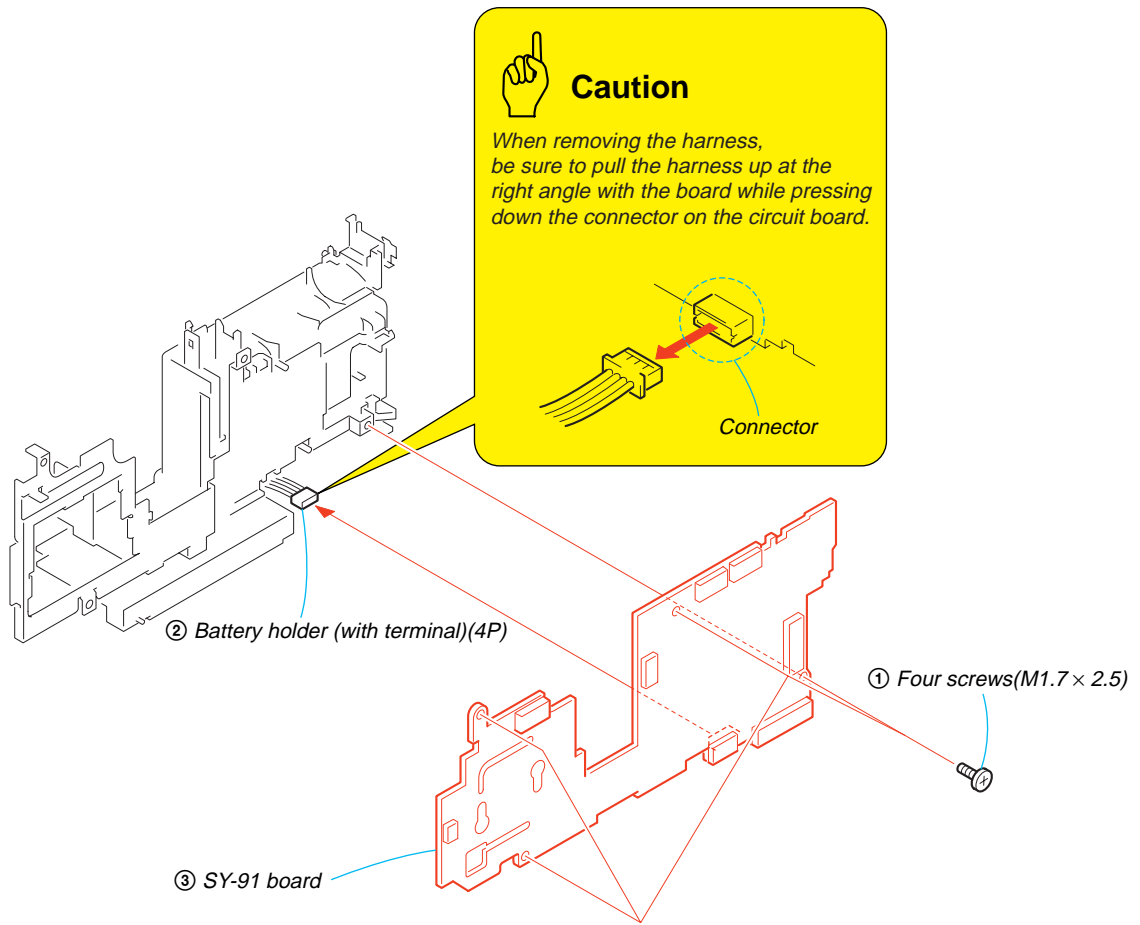

[SERVICE POSITION (SY-91 BOARD)]

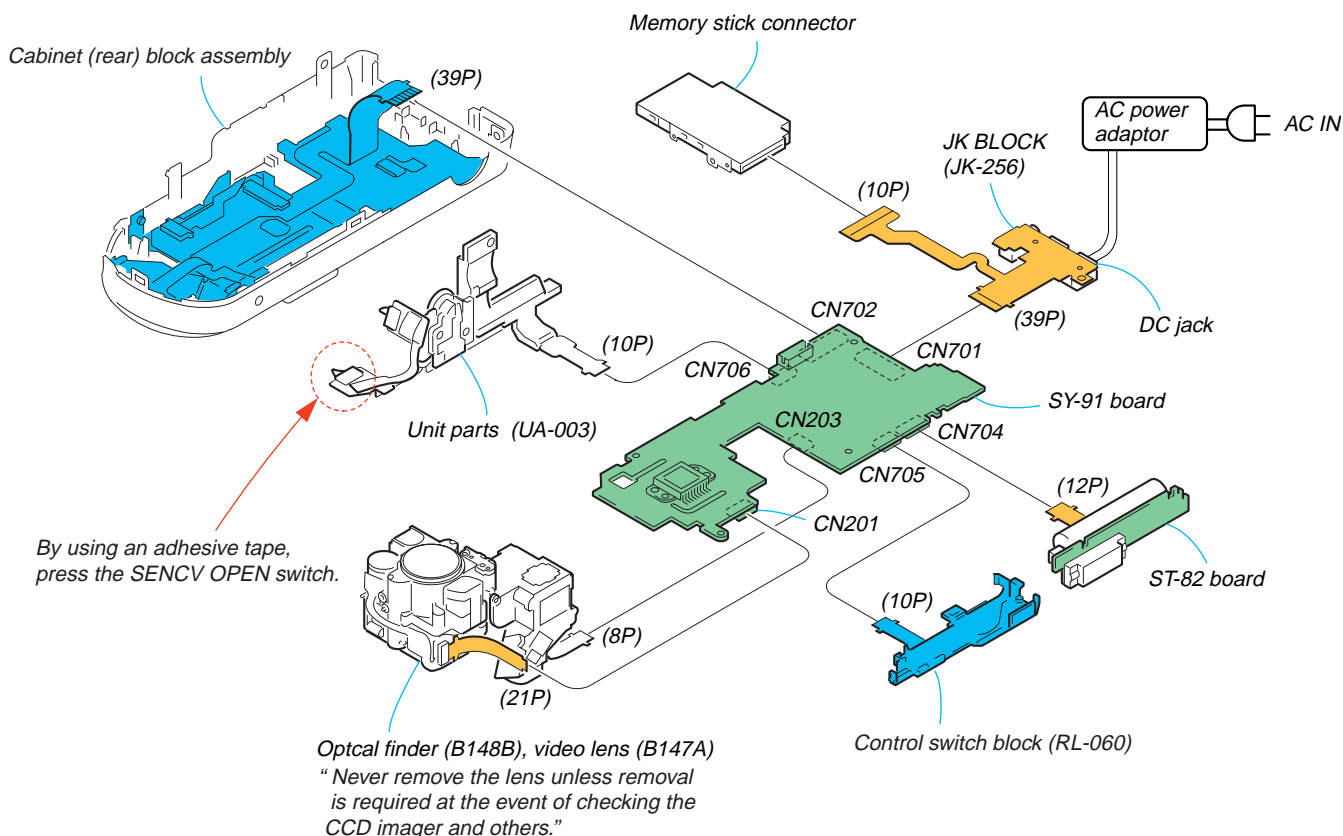

PROCEDURE OF REMOVING THE SY-91 BOARD (SERVICE POSITION)

- ① 2-1. CABINET (REAR) BLOCK ASSEMBLY (page 2-2)
- ② 2-2. BLOCK LIGHT GUIDE PLATE, LCD MODULE, (page 2-3)
 CONTROL SWITCH BLOCK (SW-392), LITHIUM BATTERY
- ③ 2-3. MAIN BLOCK ASSEMBLY (page 2-4)
- ④ 2-4. UNIT PARTS (UA-003), DC 8C-028G MOTOR (page 2-4)
- ⑤ 2-5. OPTICAL FINDER (B148B), VIDEO LENS (B147A), CCD BLOCK ASSEMBLY (page 2-5)
- ⑥ 2-6. CONTROL SWITCH BLOCK (RL-060), ST-82 BOARD (page 2-5)
- ⑦ 2-7. MEMORY STICK CONNECTOR, JK BLOCK (JK-256) (page 2-6)
- ⑧ 2-8. SY-91 BOARD (page 2-7)

2-9. OPTICAL FINDER (B148B), VIDEO LENS (B147A)

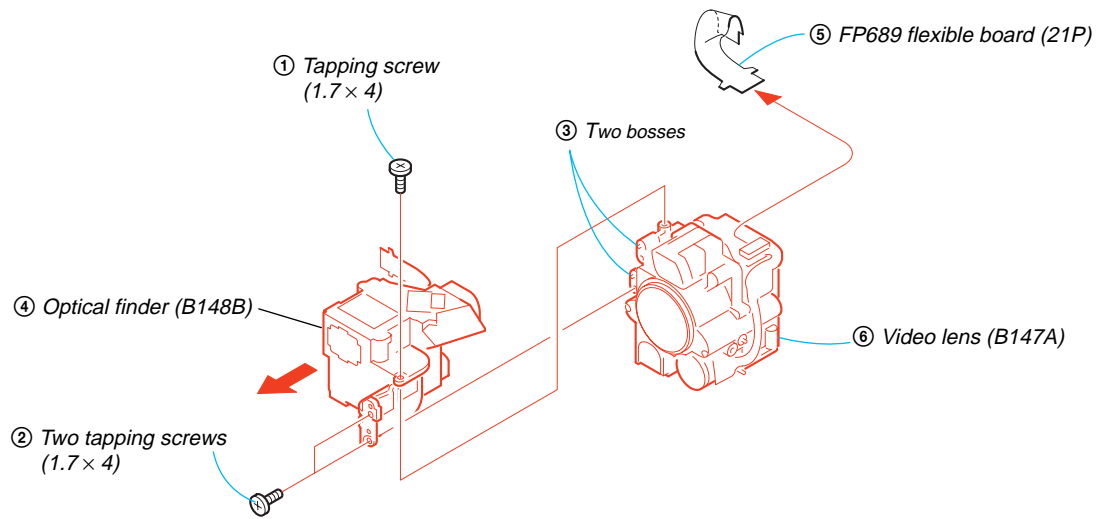

2-10. FLASH UNIT

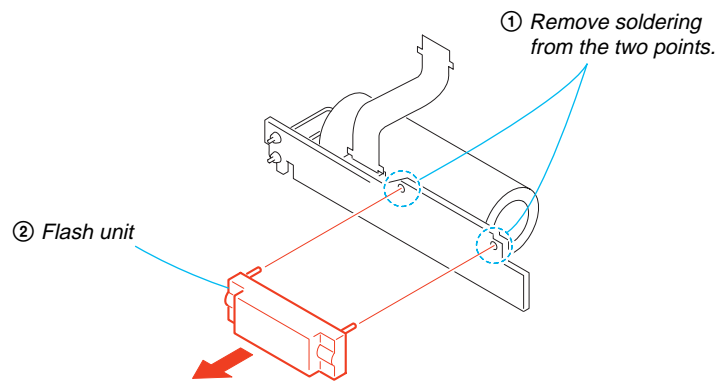



2-11. CIRCUIT BOARDS LOCATION

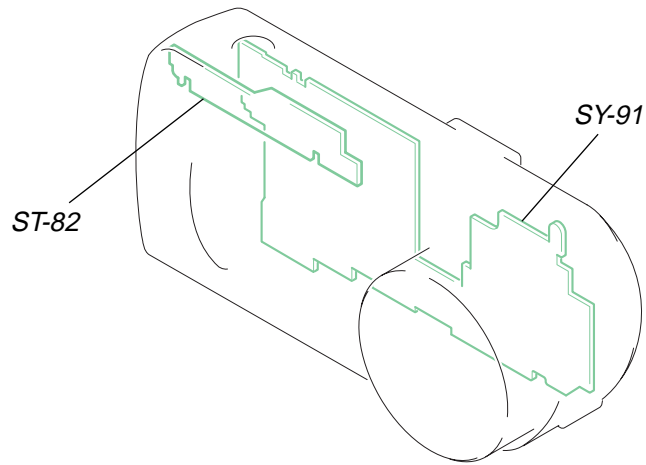

Board Name	Function
SY-91	CCD IMAGER CAMERA A/D CONV., LENS DRIVE, CAMERA DSP, VIDEO AMP, SH DSP, CLK GEN, LCD DRIVE TIMING GENERATOR, FRONT CONTROL, AUDIO I/O, DC IN, DC-DC CONVERTER, CONNECTOR
ST-82	FLASH DRIVE



2-12. FLEXIBLE BOARDS LOCATION

The flexible boards contained in the VIDEO LENS are not shown.

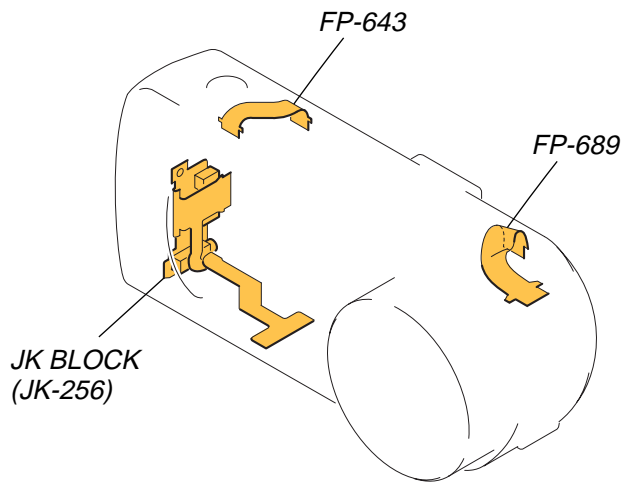
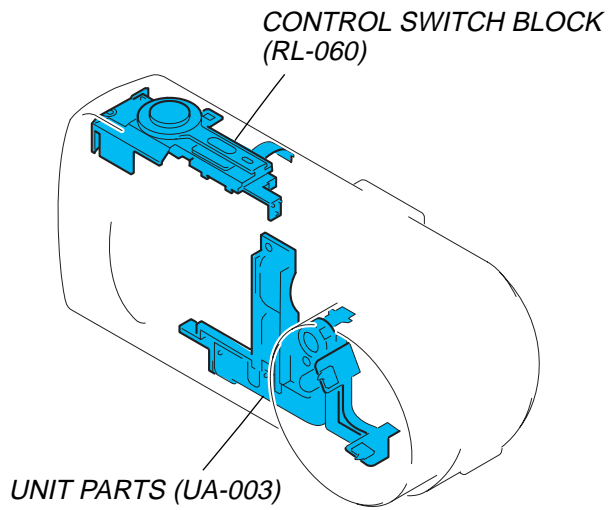
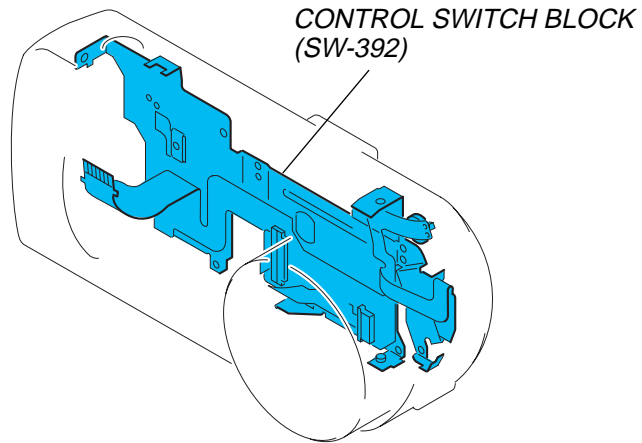



HELP

Sheet attachment positions and procedures of processing the flexible boards/harnesses are shown.

MAIN BLOCK SECTION

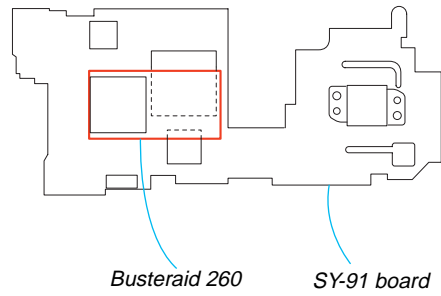
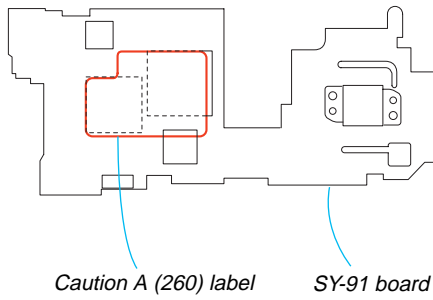
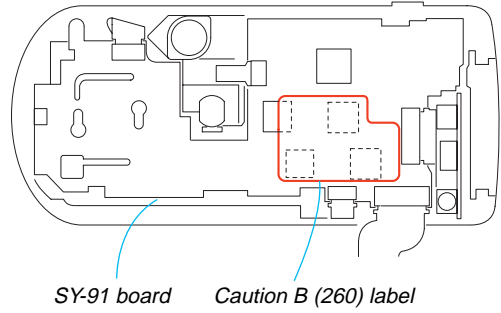
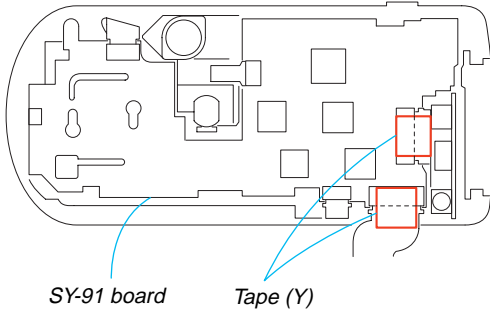



3. BLOCK DIAGRAMS

Link

• [OVERALL BLOCK DIAGRAM](#)

• [FRONT/LCD BLOCK DIAGRAM](#)

• [CAMERA BLOCK DIAGRAM](#)

• [POWER BLOCK DIAGRAM](#)



SECTION 3
BLOCK DIAGRAMS

3. BLOCK DIAGRAMS

3-1. OVERALL BLOCK DIAGRAM () : Number in parenthesis () indicates the division number of schematic diagram where the component is located.

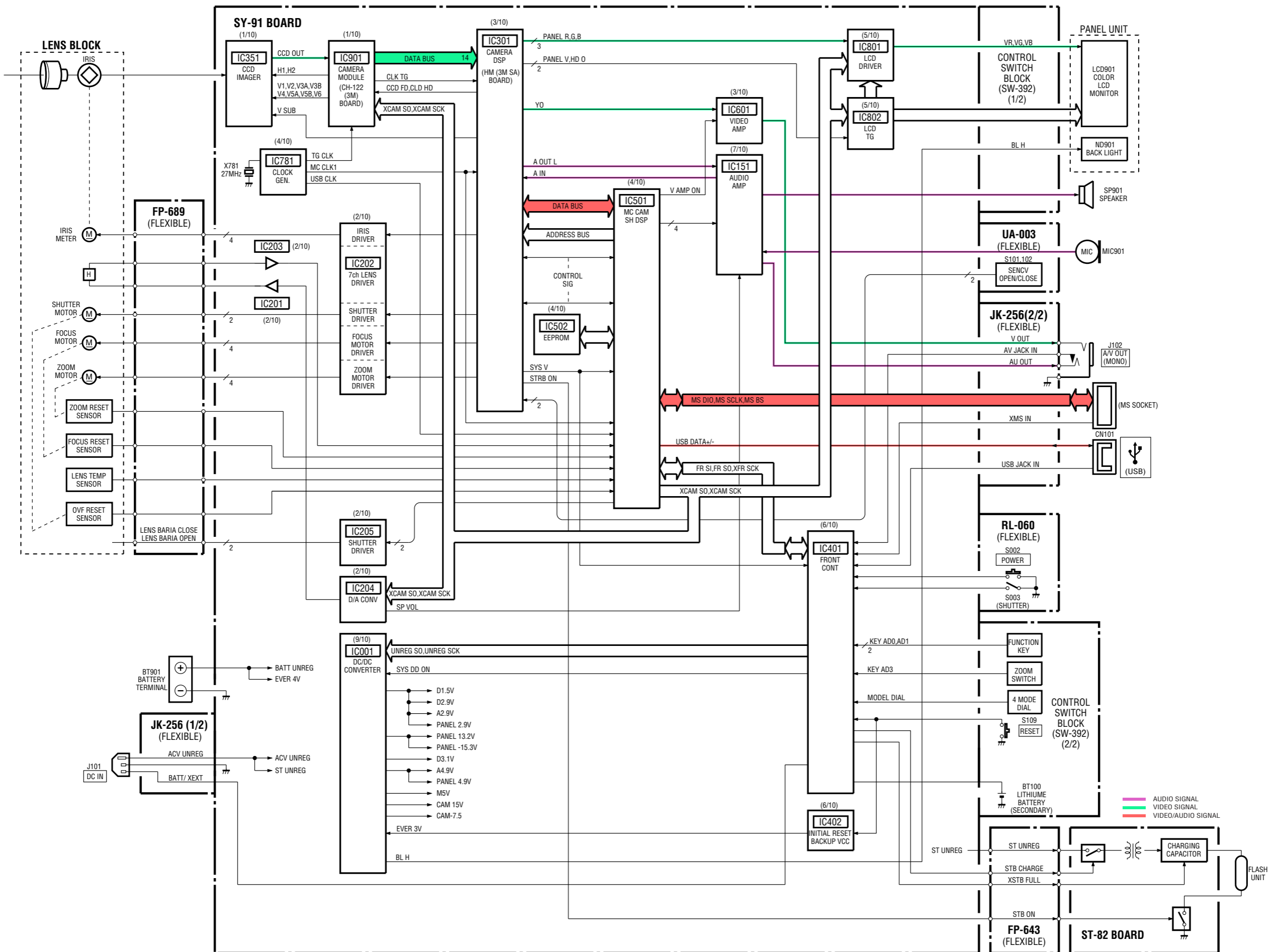



3. BLOCK DIAGRAMS

3-2. CAMERA BLOCK DIAGRAM () : Number in parenthesis () indicates the division number of schematic diagram where the component is located.

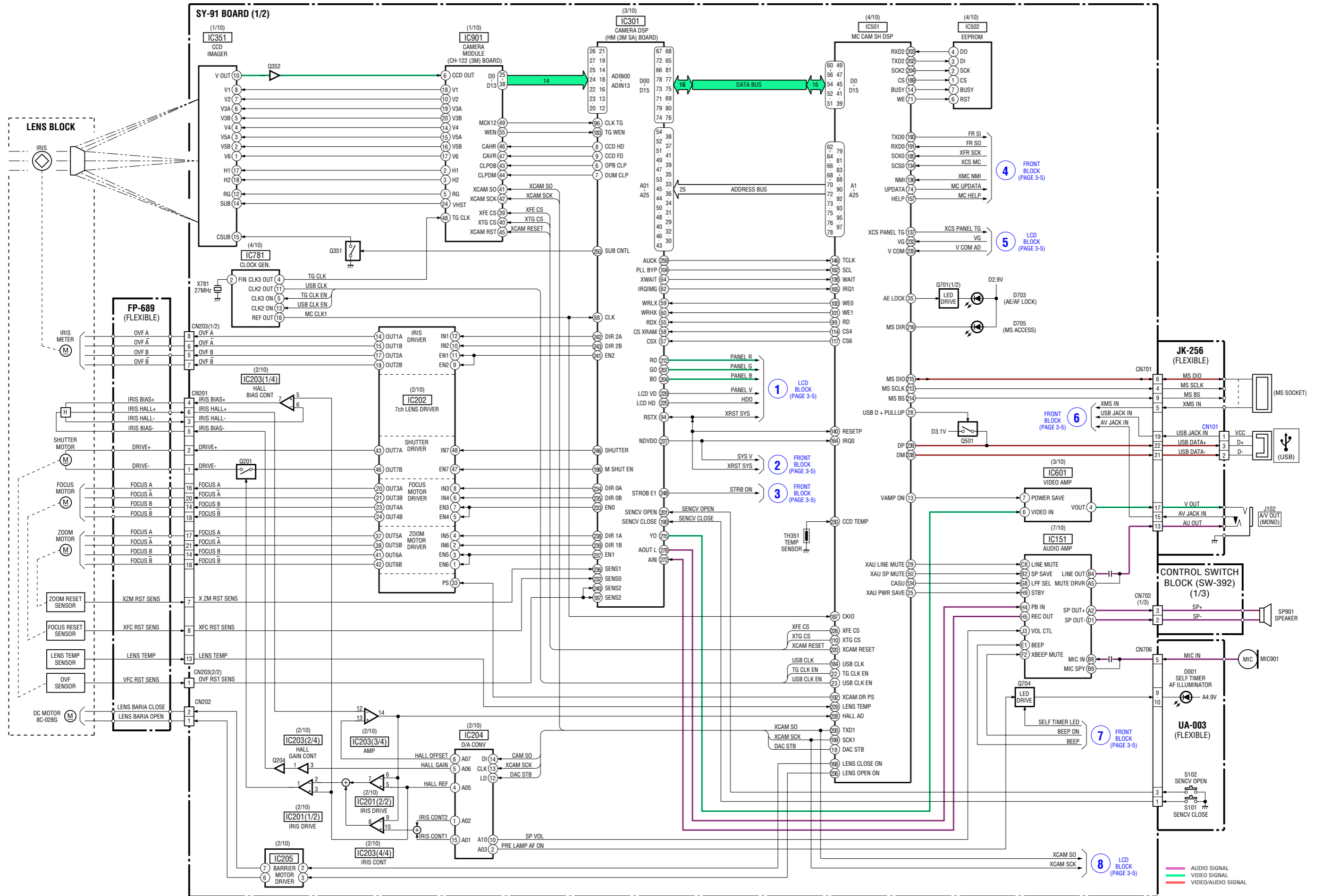



3. BLOCK DIAGRAMS

3-3. FRONT/LCD BLOCK DIAGRAM () : Number in parenthesis () indicates the division number of schematic diagram where the component is located.

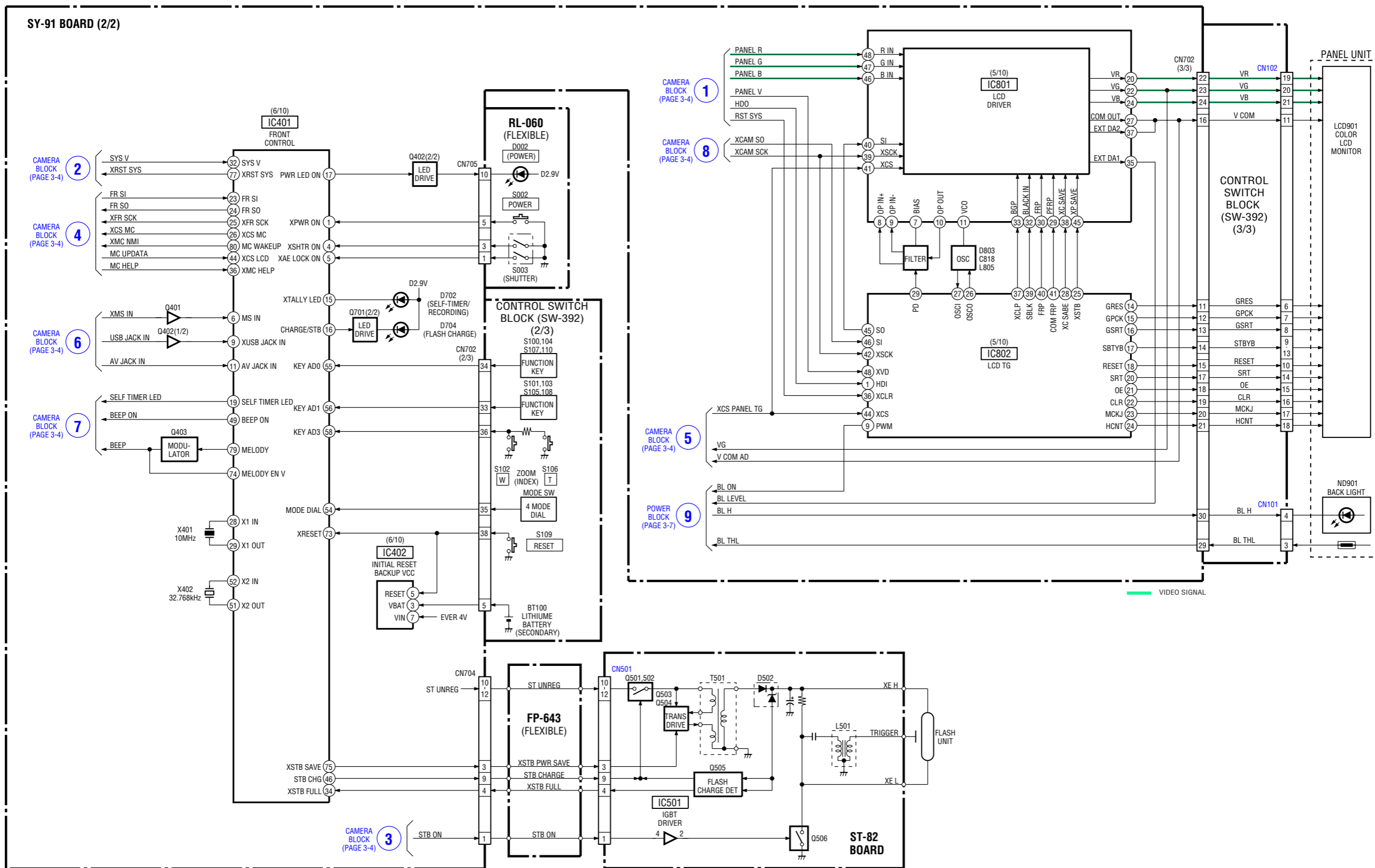



3. BLOCK DIAGRAMS

3-4. POWER BLOCK DIAGRAM () : Number in parenthesis () indicates the division number of schematic diagram where the component is located.

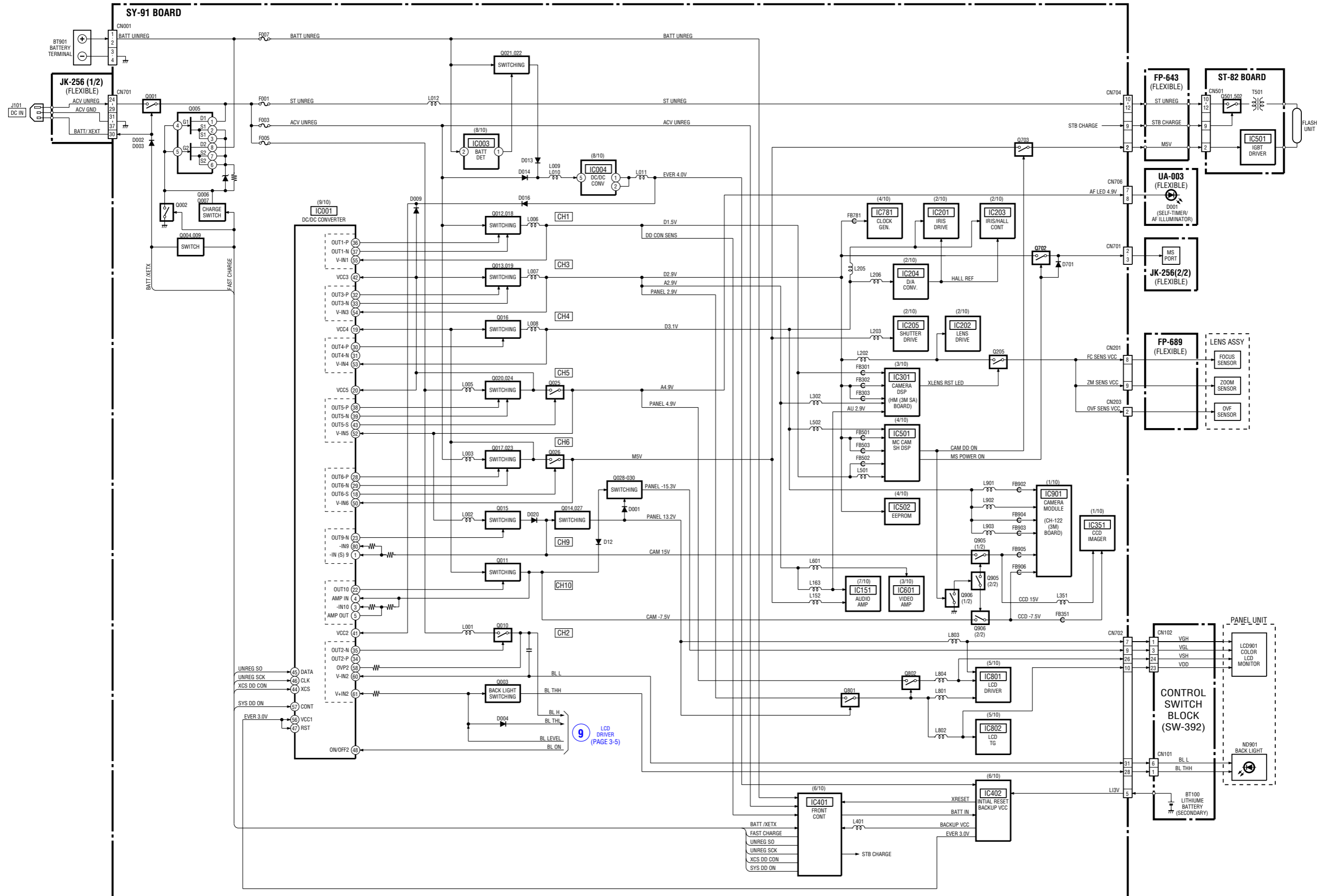



SECTION 4

PRINTED WIRING BOARDS AND SCHEMATIC DIAGRAMS

4-1. FRAME SCHEMATIC DIAGRAM (1/2)

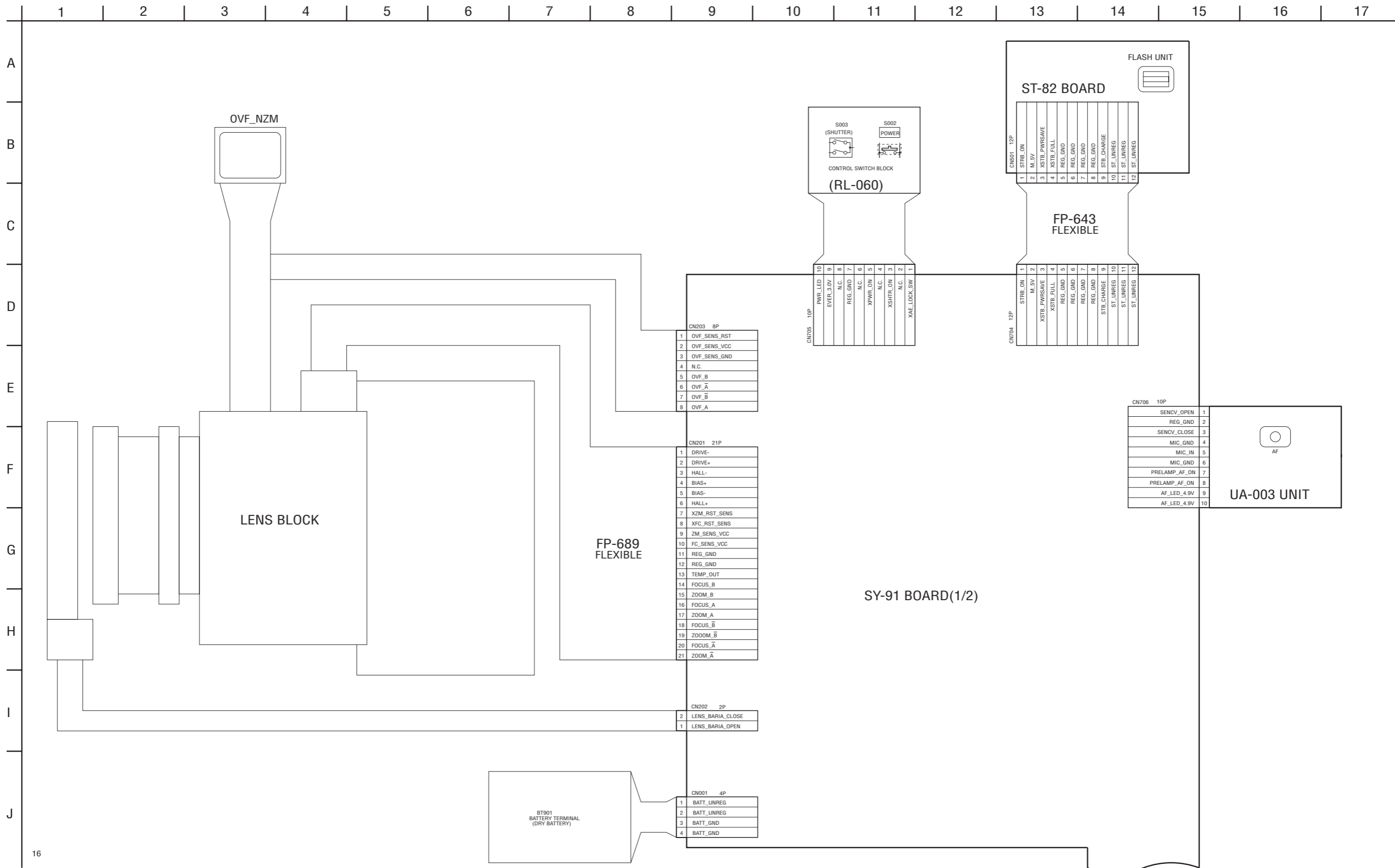

16



FRAME SCHEMATIC DIAGRAM (2/2)

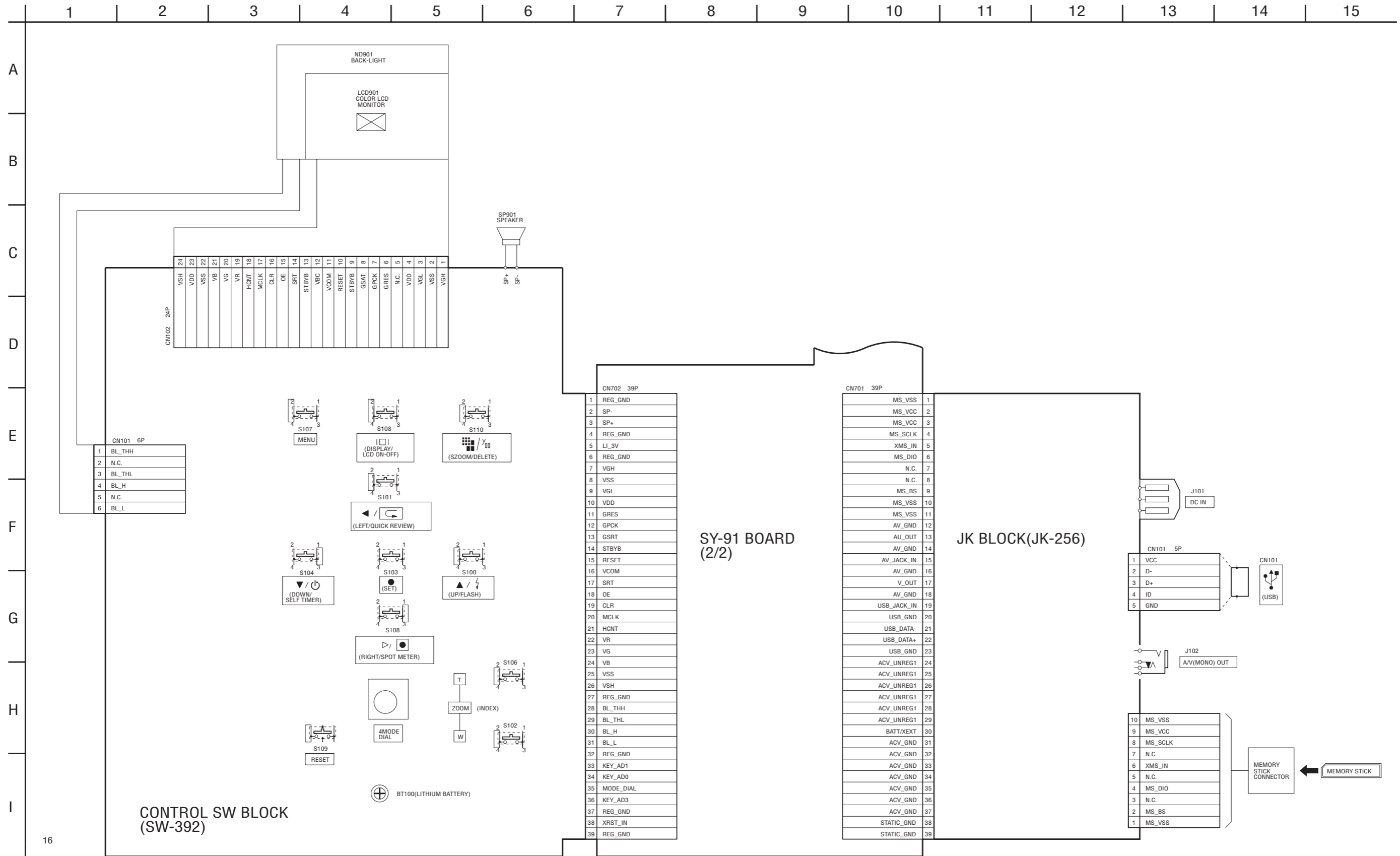



4-2. SCHEMATIC DIAGRAMS

Link

• [ST-82 BOARD \(FLASH DRIVE\)](#)

• [CONTROL SWITCH BLOCK \(SW-392\)](#)

• [FP-643 FLEXIBLE BOARD](#)

• [CONTROL SWITCH BLOCK \(RL-060\)](#)

• [JK BLOCK \(JK-256\) \(JACK\)](#)

• [UA-003 \(AF LED, SW\)](#)

• [COMMON NOTE FOR SCHEMATIC DIAGRAMS](#)



4-2. SCHEMATIC DIAGRAMS

THIS NOTE IS COMMON FOR SCHEMATIC DIAGRAMS
 (In addition to this, the necessary note is printed in each block)

(For schematic diagrams)

- All capacitors are in μF unless otherwise noted. $\text{pF} : \mu\text{F} : 50\text{V}$ or less are not indicated except for electrolytics and tantalums.
- Chip resistors are $1/10\text{W}$ unless otherwise noted. $\text{k}\Omega=1000\ \Omega$, $\text{M}\Omega=1000\ \text{k}\Omega$.
- Caution when replacing chip parts. New parts must be attached after removal of chip. Be careful not to heat the minus side of tantalum capacitor, Because it is damaged by the heat.
- Some chip part will be indicated as follows.

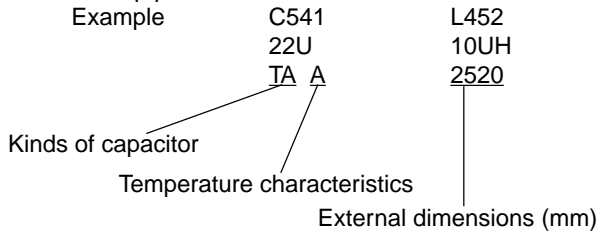

- Constants of resistors, capacitors, ICs and etc with XX indicate that they are not used. In such cases, the unused circuits may be indicated.
- Parts with * differ according to the model/destination. Refer to the mount table for each function.
- All variable and adjustable resistors have characteristic curve B, unless otherwise noted.
- Signal name
 $\text{XEDIT} \rightarrow \text{EDIT}$ $\text{PB/XREC} \rightarrow \text{PB/REC}$
- : non flammable resistor
- : fusible resistor
- : panel designation
- : B+ Line
- : B- Line
- : IN/OUT direction of (+,-) B LINE.
- : adjustment for repair.
- : VIDEO SIGNAL (ANALOG)
- : AUDIO SIGNAL (ANALOG)
- : VIDEO/AUDIO SIGNAL
- : VIDEO/AUDIO/SERVO SIGNAL
- : SERVO SIGNAL
- Circled numbers refer to waveforms.

(Measuring conditions voltage and waveform)

- Voltages and waveforms are measured between the measurement points and ground when camera shoots color bar chart of pattern box. They are reference values and reference waveforms. (VOM of DC $10\ \text{M}\Omega$ input impedance is used)
- Voltage values change depending upon input impedance of VOM used.)

1. Connection

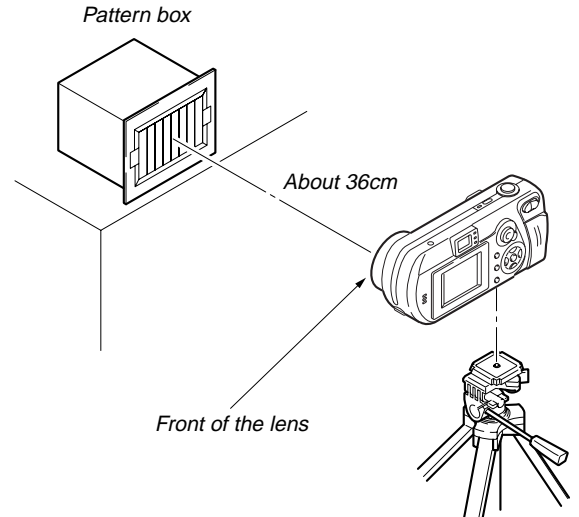

2. Adjust the distance so that the output waveform of Fig. a and the Fig. b can be obtain.

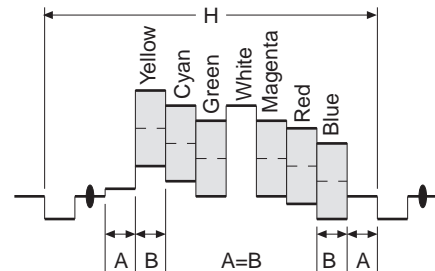

Fig. a (Video output terminal output waveform)

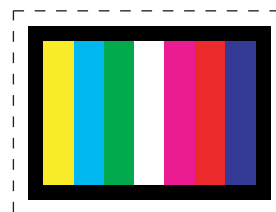

Fig.b (Picture on monitor TV)

When indicating parts by reference number, please include the board name.

Note :
 The components identified by mark Δ or dotted line with mark Δ are critical for safety. Replace only with part number specified.

Note :
 Les composants identifiés par une marque Δ sont critiques pour la sécurité. Ne les remplacer que par une pièce portant le numéro spécifié.



4-2. SCHEMATIC DIAGRAMS

ST-82 PRINTED WIRING BOARD

4-2. SCHEMATIC DIAGRAMS

For Schematic Diagram
 • Refer to page 4-37 for printed wiring board of ST-82 board.

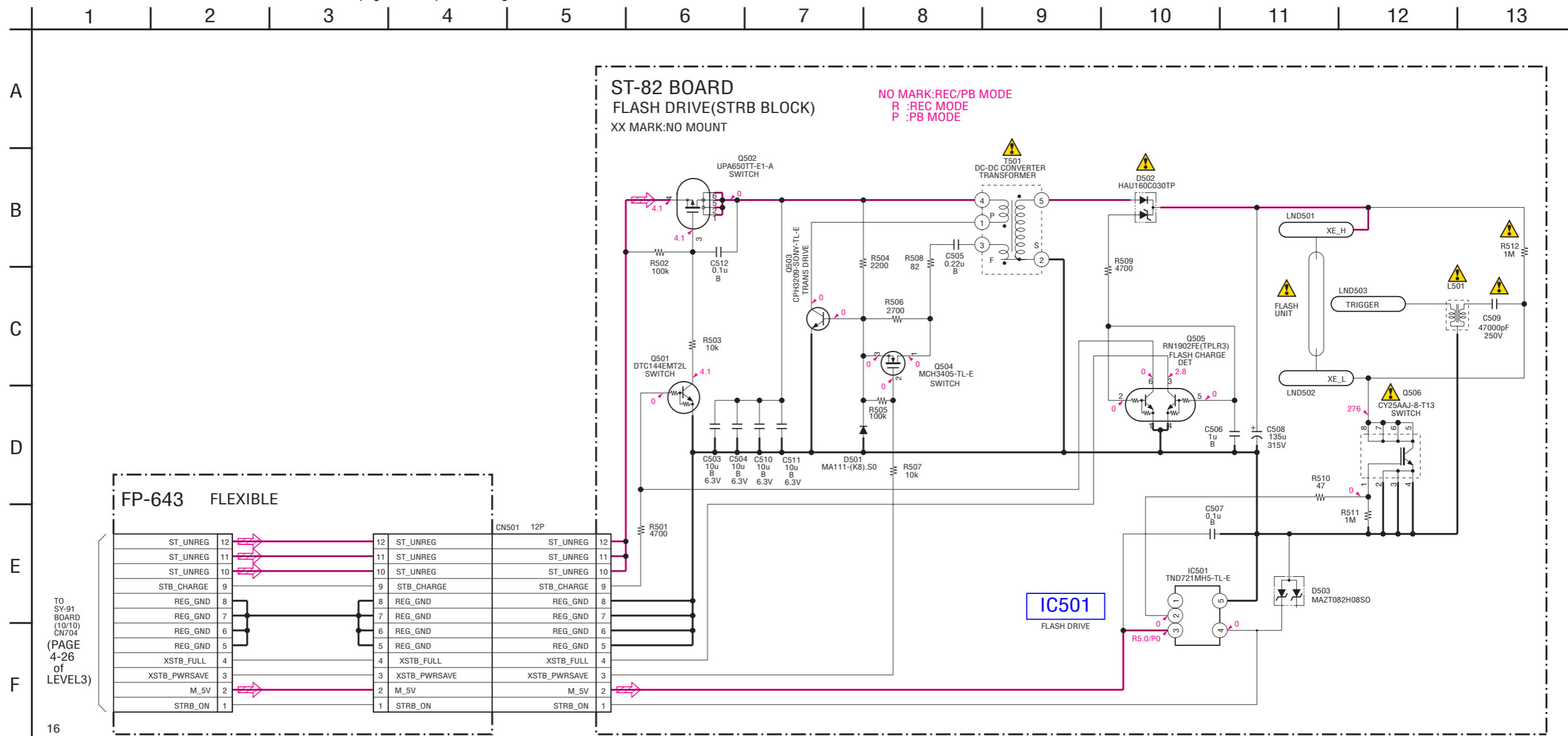

Note :
 The components identified by mark Δ or dotted line with mark Δ are critical for safety. Replace only with part number specified.

Note :
 Les composants identifiés par une marque Δ sont critiques pour la sécurité. Ne les remplacer que par une pièce portant le numéro spécifié.

Schematic diagram of the SY-91 board are not shown. Pages from 4-7 to 4-26 are not shown.

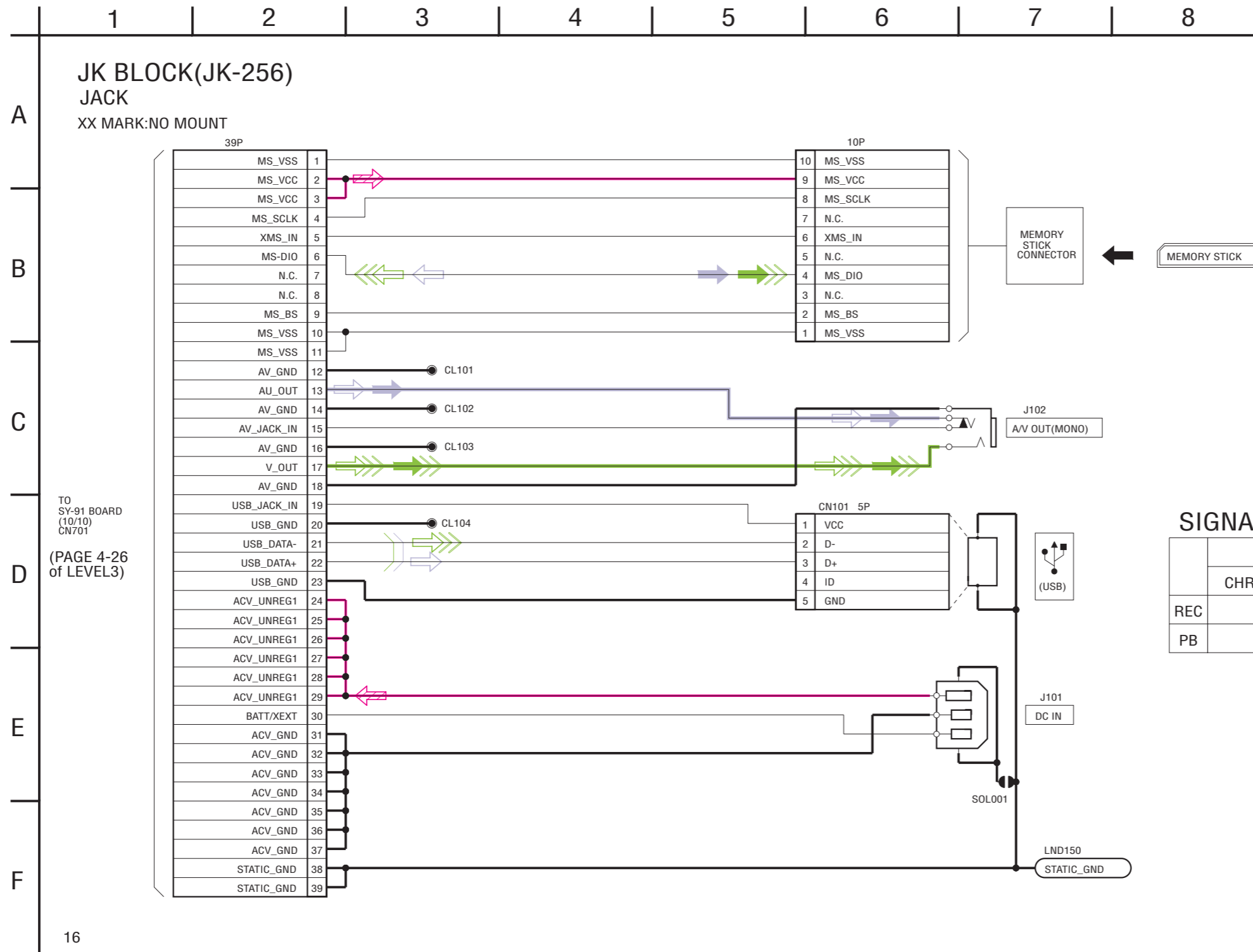

SIGNAL PATH

	VIDEO SIGNAL			AUDIO SIGNAL
	CHROMA	Y	Y/CHROMA	
REC			➡➡➡	➡
PB			➡➡➡	➡



4-2. SCHEMATIC DIAGRAMS

4-3. PRINTED WIRING BOARDS

• CONTROL SWITCH BLOCK (SW-392) is replaced as a block. So that this PRINTED WIRING BOARD is omitted.

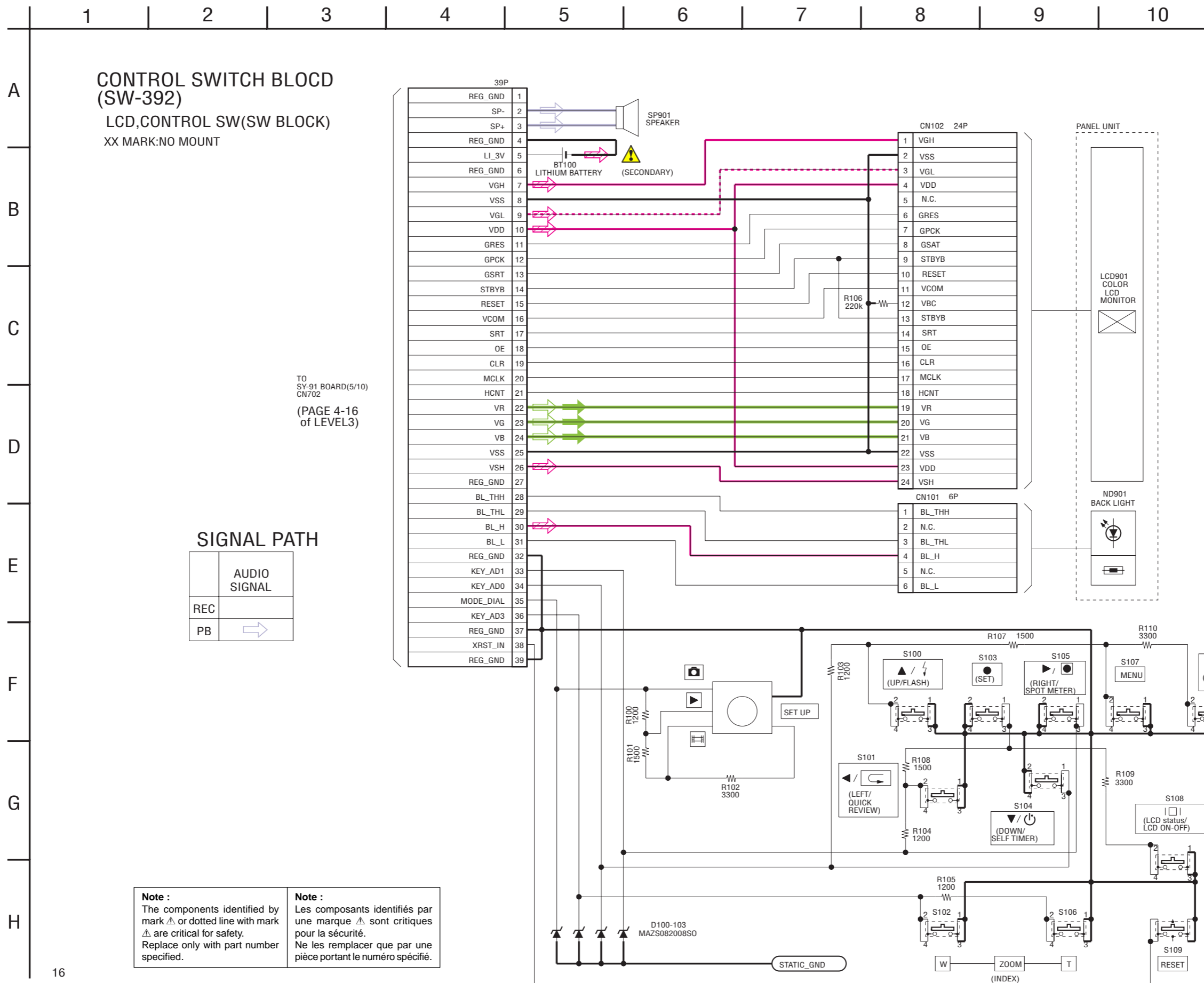



• CONTROL SWITCH BLOCK (RL-060) is replaced as a block. So that this PRINTED WIRING BOARD is omitted.

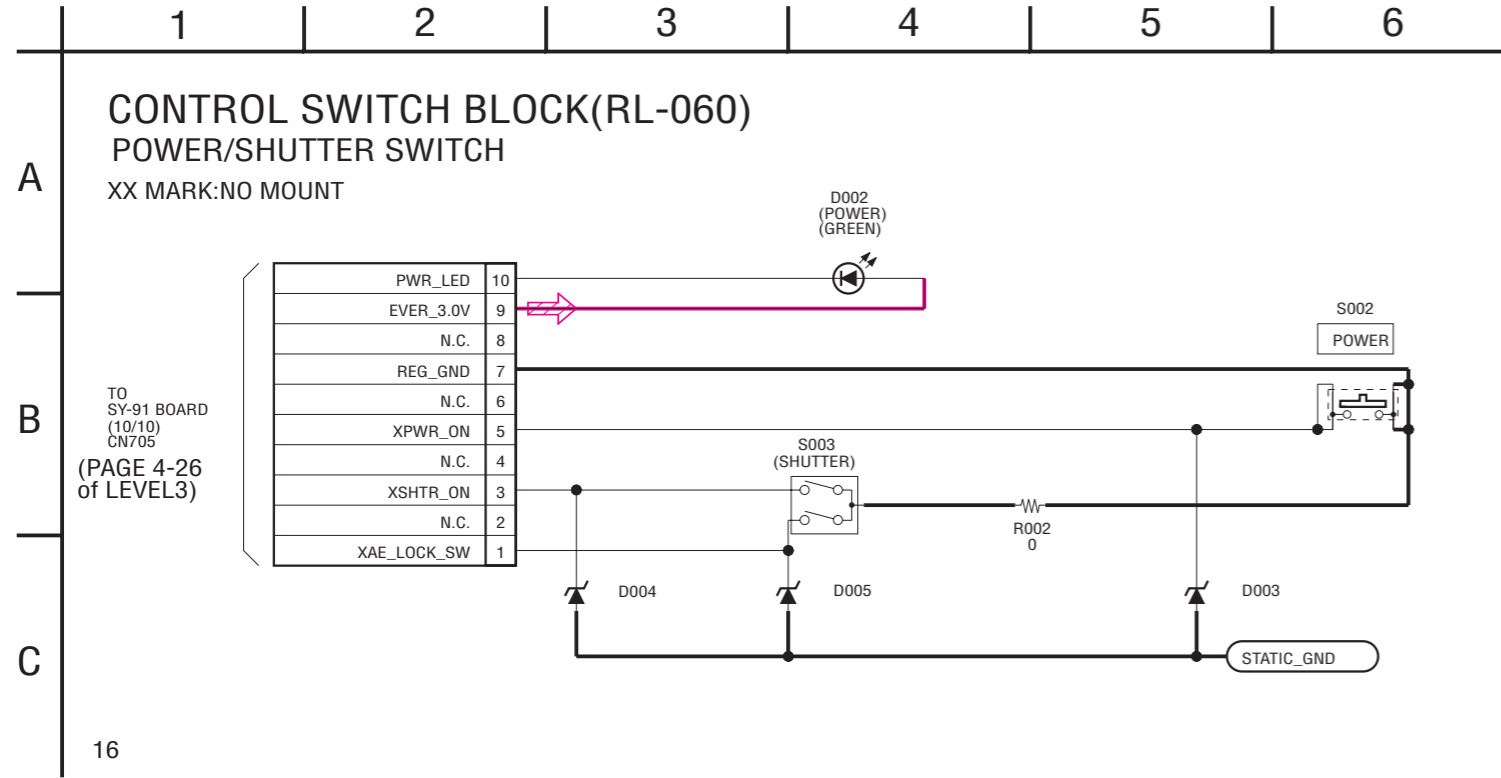

• UA-003 UNIT is replaced as a block. So that this PRINTED WIRING BOARD is omitted.

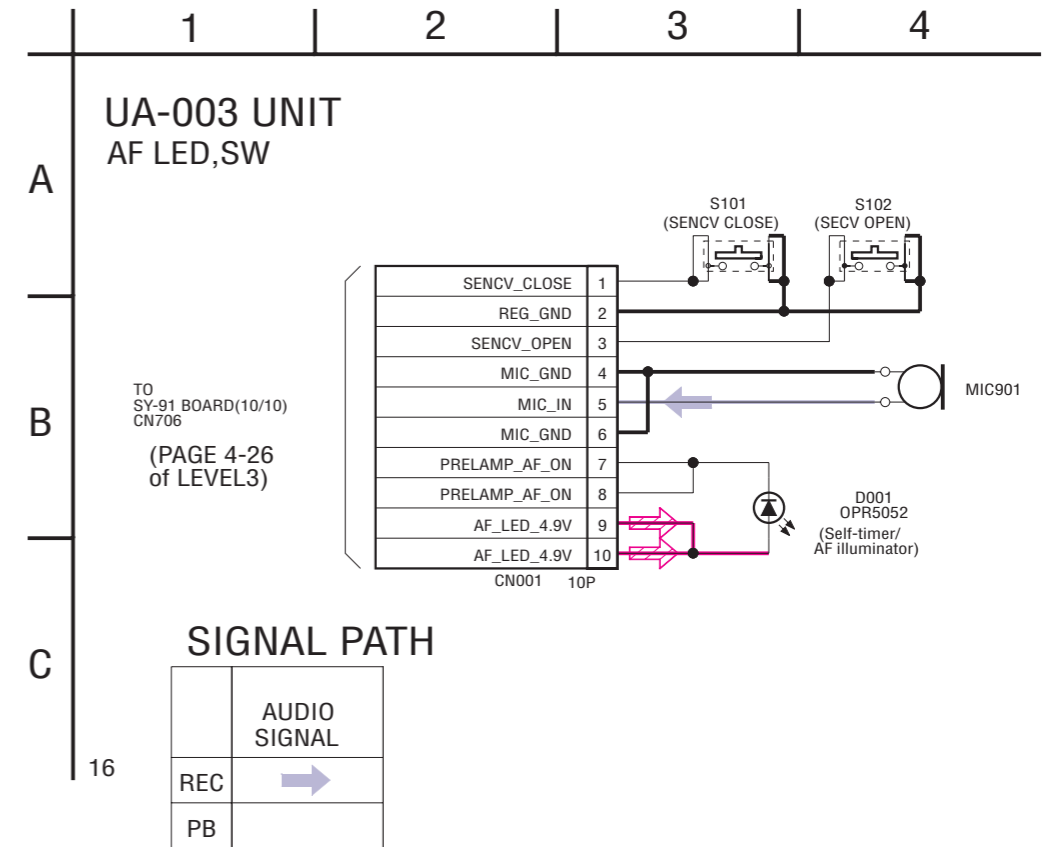



4-3. PRINTED WIRING BOARDS

Link

• [ST-82 BOARD](#)

• [JK BLOCK \(JK-256\)](#)

• [COMMON NOTE FOR PRINTED WIRING BOARDS](#)

• [MOUNTED PARTS LOCATION](#)

• [CIRCUIT BOARDS LOCATION](#)

• [FLEXIBLE BOARDS LOCATION](#)



4-3. PRINTED WIRING BOARDS

THIS NOTE IS COMMON FOR WIRING BOARDS
 (In addition to this, the necessary note is printed in each block)

(For printed wiring boards)

- : Uses unleaded solder.
- : Pattern from the side which enables seeing.
 (The other layers' patterns are not indicated)
- Through hole is omitted.
- Circled numbers refer to waveforms.
- There are a few cases that the part printed on diagram isn't mounted in this model.
- : panel designation

• Chip parts.

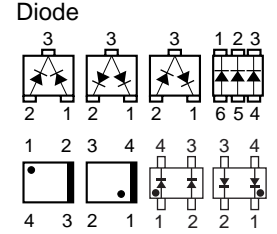
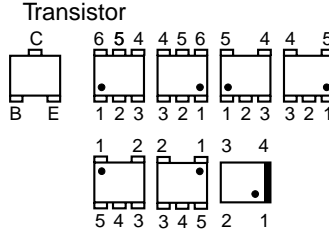

BOARD INFORMATION

board name	parts location (shown on page)	waveform (shown on page)	pattern		CSP IC
			number of layers	layers not shown	
ST-82	4-47	—	4	2 to 3	—
JK BLOCK	—	—	1	—	—
SY-91	4-48	4-45	8	2 to 7	IC151, 401, 501, 001, 301, 901



4-3. PRINTED WIRING BOARDS

ST-82 (FLASH DRIVE) PRINTED WIRING BOARD

• Refer to page 4-35 for common note for printed wiring board.

• : Uses unleaded solder.

ST-82 BOARD(SIDE A)

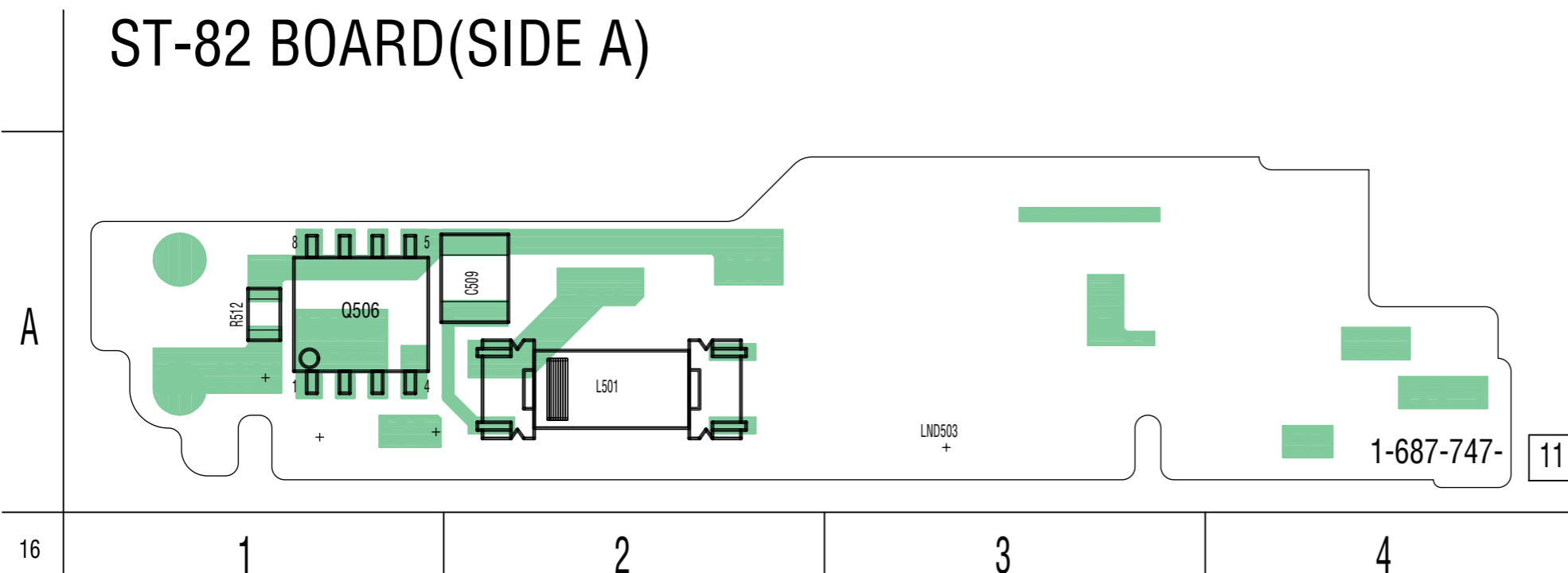

ST-82 BOARD(SIDE B)

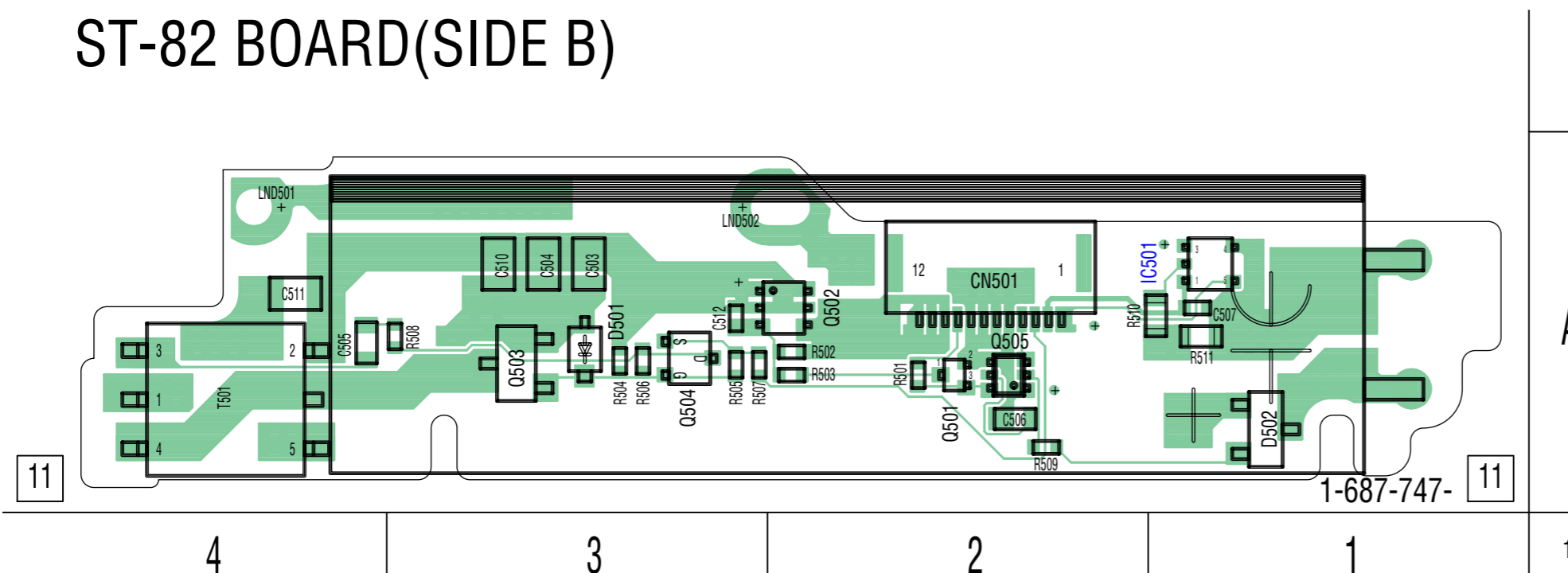

Printed wiring board of the SY-91 board are not shown. Pages from 4-39 to 4-42 are not shown.



JK BLOCK (JK-256) (JACK) FLEXIBLE BOARD

JK BLOCK (JK-256)

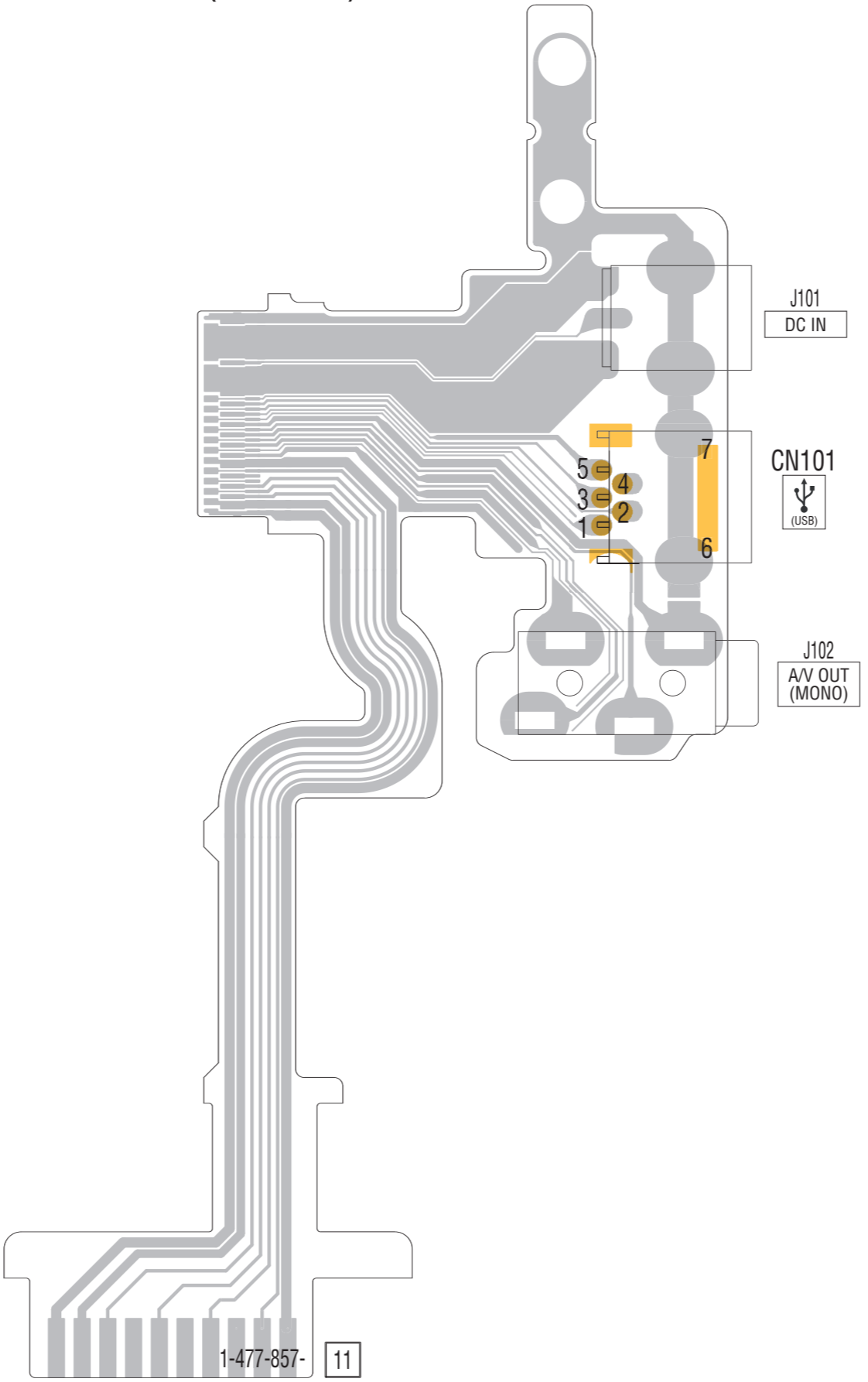

Waveforms of the SY-91 board are not shown. Pages from 4-45 to 4-46 are not shown.



4-3. PRINTED WIRING BOARDS

4-5. MOUNTED PARTS LOCATION

no mark : side A

* mark : side B

ST-82 BOARD

* C503 A-3
 * C504 A-3
 * C505 A-4
 * C506 A-2
 * C507 A-1
 C509 A-1
 * C510 A-3
 * C511 A-4
 * C512 A-3

 * CN501 A-2

 * D502 A-1

 * IC501 A-1

 L501 A-1

 * Q502 A-3
 * Q503 A-3
 * Q504 A-3
 * Q505 A-2
 Q506 A-1

 * R501 A-2
 * R502 A-3
 * R503 A-3
 * R504 A-3
 * R505 A-3
 * R506 A-3
 * R508 A-4
 * R509 A-2
 * R510 A-1
 * R511 A-1
 R512 A-1

 * T501 A-4

Mounted parts location of the SY-91 board
 is not shown.
 Page 4-48 is not shown.



5. REPAIR PARTS LIST

NOTE: Characters **A** to **Z** of the electrical parts list indicate location of exploded views in which the desired part is shown.

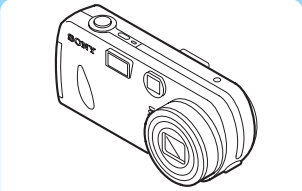
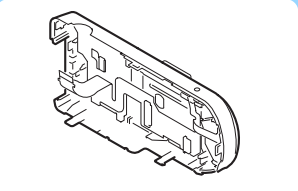
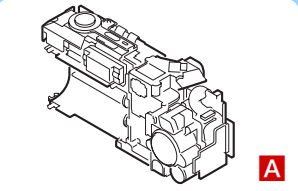
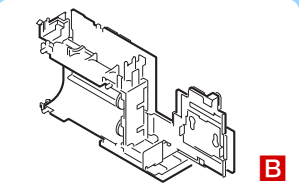
Link	EXPLODED VIEWS		
			
CABINET (FRONT) SECTION	CABINET (REAR) BLOCK SECTION	MAIN BLOCK SECTION-1 A	MAIN BLOCK SECTION-2 B

Link	ELECTRICAL PARTS LIST		ACCESSORIES
SY-91 BOARD A	ST-82 BOARD B		



5. REPAIR PARTS LIST

NOTE:

- -XX, -X mean standardized parts, so they may have some differences from the original one.
- Items marked "*" are not stocked since they are seldom required for routine service. Some delay should be anticipated when ordering these items.
- The mechanical parts with no reference number in the exploded views are not supplied.
- Due to standardization, replacements in the parts list may be different from the parts specified in the diagrams or the components used on the set.
- CAPACITORS:
uF: μ F
- COILS
uH: μ H
- RESISTORS
All resistors are in ohms.
METAL: metal-film resistor
METAL OXIDE: Metal Oxide-film resistor
F: nonflammable
- SEMICONDUCTORS
In each case, u: μ , for example:
uA...: μ A... , uPA... , μ PA... ,
uPB... , μ PB... , uPC... , μ PC... ,
uPD... , μ PD...
- Abbreviation
CND : Canadian model
AUS : Australian model
JE : Tourist model
CH : Chinese model
KR : Korea model
HK : Hong Kong model
BR : Brazilian model

When indicating parts by reference number, please include the board name.

The components identified by mark \triangle or dotted line with mark \triangle are critical for safety. Replace only with part number specified.

Les composants identifiés par une marque \triangle sont critiques pour la sécurité. Ne les remplacer que par une pièce portant le numéro spécifié.



5. REPAIR PARTS LIST

5-1. EXPLODED VIEWS

5-1-1. CABINET (FRONT) SECTION

ns : not supplied

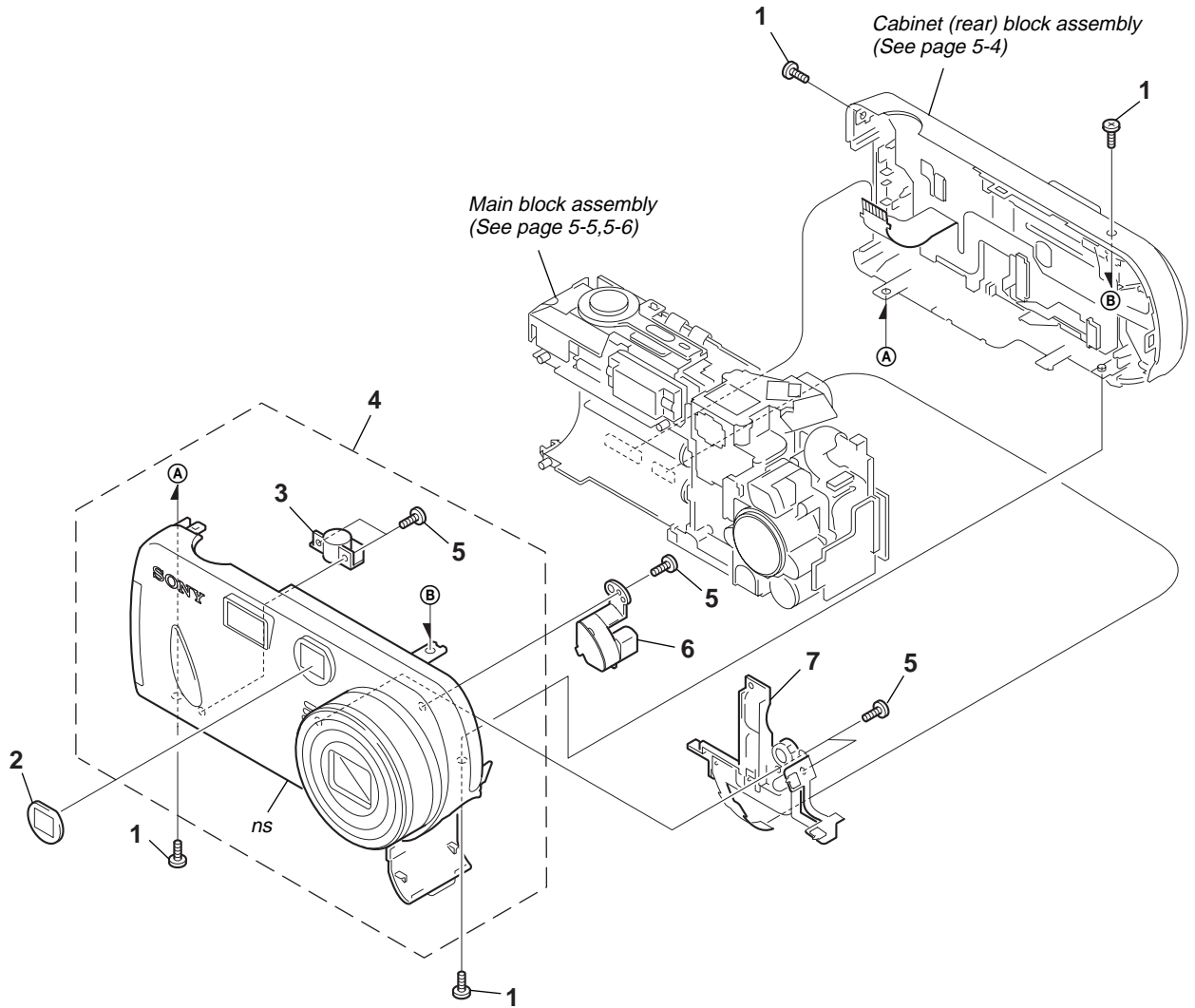

Ref. No.	Part No.	Description	Remarks	Ref. No.	Part No.	Description	Remarks
1	3-968-729-71	SCREW (M2), LOCK ACE, P2		5	3-080-204-21	SCREW, TAPPING, P2	
2	3-082-151-01	OVF, WINDOW		6	1-763-818-31	DC MOTOR 8C-028G	
3	3-080-977-01	TRIPOD		7	1-477-908-11	UNIT PARTS (UA-003)	
4	X-3953-322-1	CABINET (FRONT) ASSY					



5. REPAIR PARTS LIST

5-1-2. CABINET (REAR) BLOCK SECTION

ns : not supplied

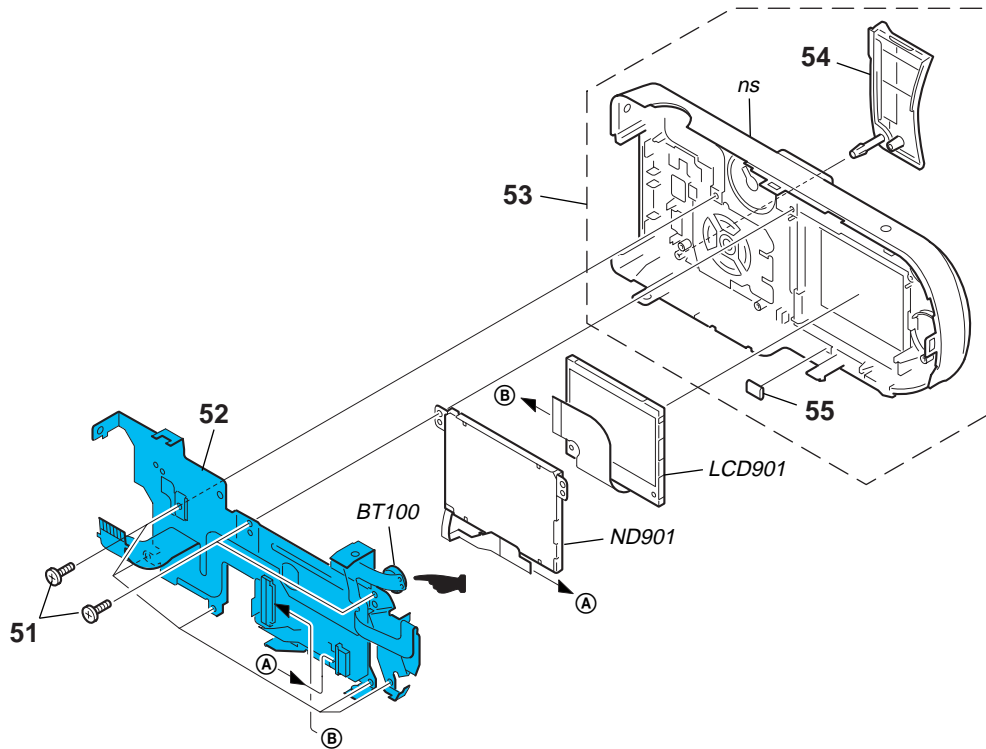

: For the installation position of BT100 (Lithium battery), refer to page 2-3

CAUTION :

Danger of explosion if battery is incorrectly replaced.
Replace only with the same or equivalent type.

Ref. No.	Part No.	Description	Remarks	Ref. No.	Part No.	Description	Remarks
51	3-078-890-11	SCREW, TAPPING		55	3-083-057-01	CUSHION (ISB), ELECTROSTATIC	
52	1-477-906-11	CONTROL SWITCH BLOCK (SW-392)		△ND901	1-477-761-11	BLOCK LIGHT GUIDE PLATE (1.5)	
53	X-3953-323-1	CABINET (REAR) ASSY		LCD901	1-805-168-21	INDICATOR MODULE LIQUID CRYST	
54	3-080-985-01	COVER, JACK					

Note :

The components identified by mark △ or dotted line with mark △ are critical for safety.
Replace only with part number specified.

Note :

Les composants identifiés par une marque △ sont critiques pour la sécurité.
Ne les remplacer que par une pièce portant le numéro spécifié.



5. REPAIR PARTS LIST

5-1-3. MAIN BLOCK SECTION-1

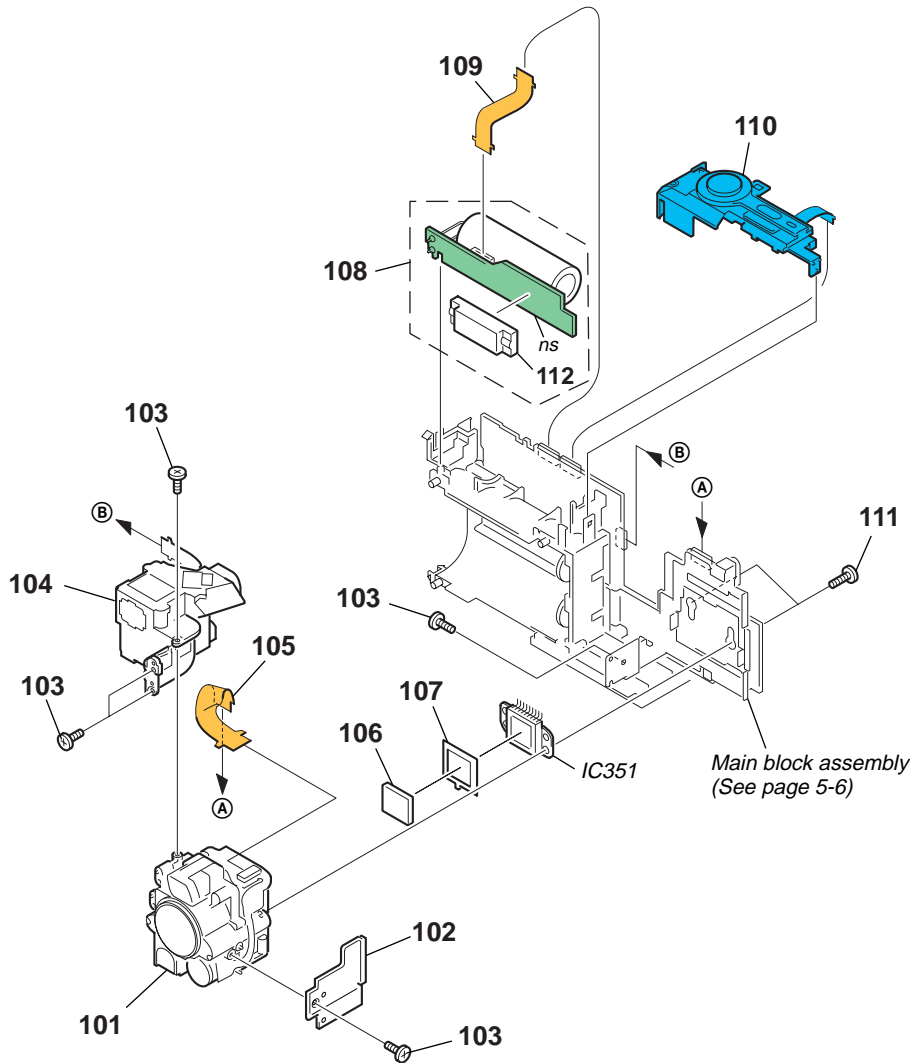

Be sure to read "Precautions upon replacing CCD imager" on page 4-8 when changing the CCD imager.

Ref. No.	Part No.	Description	Remarks	Ref. No.	Part No.	Description	Remarks
101	1-758-754-11	LENS, VIDEO (B147A)		108	A-7078-675-A	ST-82 (SL) BOARD, COMPLETE	
102	3-082-165-01	FRAME (R), LENS		109	1-687-751-11	FP-643 FLEXIBLE BOARD	
103	3-078-890-11	SCREW, TAPPING		110	1-477-907-11	CONTROL SWITCH BLOCK (RL-060)	
104	1-758-923-11	FINDER, OPTICAL (B148B)		111	3-080-204-21	SCREW, TAPPING, P2	
105	1-688-214-11	FP-689 FLEXIBLE BOARD		△ 112	1-477-895-11	FLASH UNIT	
106	1-758-916-11	FILTER BLOCK, OPTICAL		IC351	A-7016-308-A	CCD BLOCK ASSY (CCD IMAGER)	
107	3-075-085-01	RUBBER (DQ), SEAL					

<p>Note : The components identified by mark △ or dotted line with mark △ are critical for safety. Replace only with part number specified.</p>	<p>Note : Les composants identifiés par une marque △ sont critiques pour la sécurité. Ne les remplacer que par une pièce portant le numéro spécifié.</p>
---	---



5. REPAIR PARTS LIST

5-1-4. MAIN BLOCK SECTION-2

ns : not supplied

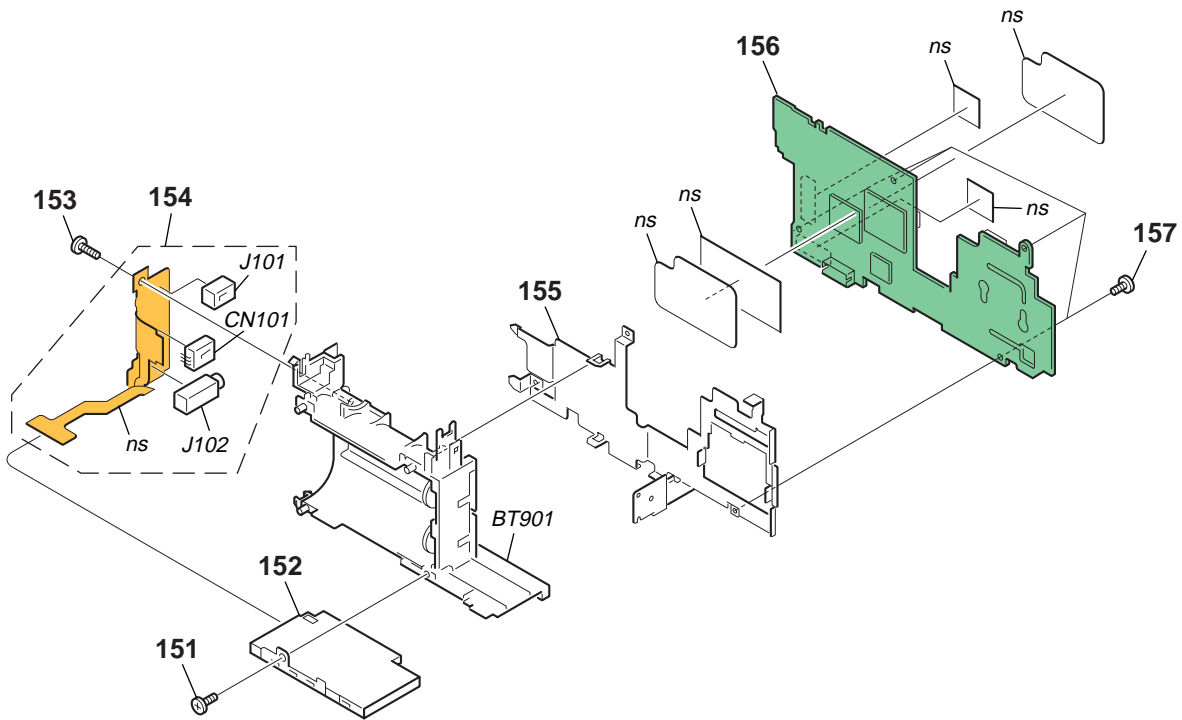

<u>Ref. No.</u>	<u>Part No.</u>	<u>Description</u>	<u>Remarks</u>	<u>Ref. No.</u>	<u>Part No.</u>	<u>Description</u>	<u>Remarks</u>
151	3-078-890-11	SCREW, TAPPING		157	3-078-889-11	SCREW (M1.7)	
152	1-815-853-21	MEMORY STICK CONNECTOR		BT901	1-756-358-11	BATTERY HOLDER (WITH TERMINAL)	
153	3-080-204-21	SCREW, TAPPING, P2		CN101	1-794-962-11	CONNECTOR, SQUARE TYPE(USB 5P)	
154	1-477-857-11	JK BLOCK (JK-256)		J101	1-817-331-11	DC JACK 5P (DC IN)	
155	3-082-162-01	FRAME, LENS		J102	1-569-950-31	JACK (SMALL TYPE) (A/V OUT (MONO))	
156	A-7078-686-A	SY-91 BOARD, COMPLETE (SERVICE)					

SY-91

ST-82

5-2. ELECTRICAL PARTS LIST

Ref. No.	Part No.	Description
	A-7078-686-A	SY-91 BOARD, COMPLETE *****

**Electrical parts list of the SY-91 board are not shown.
Pages from 5-7 to 5-13 are not shown.**

	A-7078-675-A	ST-82 (SL) BOARD, COMPLETE *****
--	--------------	-------------------------------------

△ 1-477-895-11 FLASH UNIT

< CAPACITOR >

C503	1-137-710-11	CERAMIC CHIP	10uF	20%	6.3V
C504	1-137-710-11	CERAMIC CHIP	10uF	20%	6.3V
C505	1-127-715-91	CERAMIC CHIP	0.22uF	10%	16V
C506	1-125-837-91	CERAMIC CHIP	1uF	10%	6.3V
C507	1-125-777-11	CERAMIC CHIP	0.1uF	10%	10V
C508	1-100-542-11	ELECT	135uF	99%	315V
△ C509	1-137-723-21	CERAMIC CHIP	0.047uF	10%	250V
C510	1-137-710-11	CERAMIC CHIP	10uF	20%	6.3V
C511	1-137-710-11	CERAMIC CHIP	10uF	20%	6.3V
C512	1-125-777-11	CERAMIC CHIP	0.1uF	10%	10V

< CONNECTOR >

CN501 1-816-644-11 FFC/FPC CONNECTOR (LIF) 12P

< DIODE >

D501 8-719-073-01 DIODE MA111-(K8).S0
△ D502 6-500-237-01 DIODE HAU160C030TP
D503 8-719-075-15 DIODE MAZT082H08S0

< IC >

IC501 6-703-635-01 IC TND721MH5-S-TL-E

< COIL >

△ L501 1-456-193-11 COIL, TRIGGER

< TRANSISTOR >

Q501 6-550-119-01 TRANSISTOR DTC144EMT2L
Q502 6-550-528-01 TRANSISTOR UPA650TT-E1-A
Q503 6-550-183-01 TRANSISTOR CPH3209-SONY-TL-E
Q504 8-729-056-01 TRANSISTOR MCH3405-TL-E
Q505 8-729-053-57 TRANSISTOR RN1902FE(TPLR3)

△ Q506 8-729-053-74 TRANSISTOR CY25AAJ-8-T13

< RESISTOR >

R501	1-218-961-11	RES-CHIP	4.7K	5%	1/16W
R502	1-218-977-11	RES-CHIP	100K	5%	1/16W
R503	1-218-965-11	RES-CHIP	10K	5%	1/16W
R504	1-218-957-11	RES-CHIP	2.2K	5%	1/16W
R505	1-218-977-11	RES-CHIP	100K	5%	1/16W

Ref. No.	Part No.	Description				
R506	1-218-958-11	RES-CHIP	2.7K	5%	1/16W	
R507	1-218-965-11	RES-CHIP	10K	5%	1/16W	
R508	1-218-940-11	RES-CHIP	82	5%	1/16W	
R509	1-218-961-11	RES-CHIP	4.7K	5%	1/16W	
R510	1-216-805-11	METAL CHIP	47	5%	1/16W	
R511	1-216-857-11	METAL CHIP	1M	5%	1/16W	
△ R512	1-216-121-11	RES-CHIP	1M	5%	1/10W	

< TRANSFORMER >

△ T501	1-437-737-11	TRANSFORMER, DC-DC CONVERTER
--------	--------------	------------------------------

<p>Note : The components identified by mark △ or dotted line with mark △ are critical for safety. Replace only with part number specified.</p>	<p>Note : Les composants identifiés par une marque △ sont critiques pour la sécurité. Ne les remplacer que par une pièce portant le numéro spécifié.</p>
---	---

Checking supplied accessories.

Make sure that the following accessories are supplied with your camcorder.

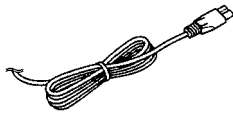

Power cord (1)(AUS model)
 ▲ 1-696-819-21
 Power cord (1)(AEP,E model)
 ▲ 1-769-608-11
 Power cord (1)(CH model)
 ▲ 1-782-476-13
 Power cord (1)(KR model)
 ▲ 1-776-985-11
 Power cord (1)(UK,HK model)
 ▲ 1-783-374-11
 Power cord (1)(US,CND model)
 ▲ 1-790-107-22
 Power cord (1)(JE model)
 ▲ 1-790-732-12

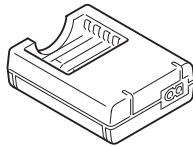

Battery charger (BC-CS2)(1)
 (US,CND,JE model)
 ▲ 1-477-814-11
 Battery charger (BC-CS2)(1)
 (AEP,UK,E,HK,AUS,BR model)
 ▲ 1-477-814-21
 Battery charger (BC-CS2)(1)
 (CH, KR model)
 ▲ 1-477-814-32



Connection cord
 (AV Cable 1.5m)(1)
 1-824-111-11

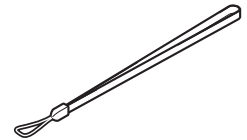

Hand strap (1)
 3-070-841-01

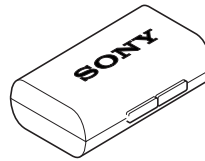

Battery carrying case (1)
 3-074-757-01



Cord with connector (1)
 (USB 5P)
 1-827-038-11

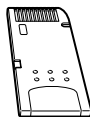

Memory stick (1)
 (MSA-16A)
 (not supplied)

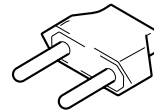

2P conversion adaptor (1)
 (JE model)
 1-569-007-12

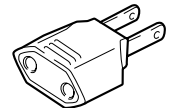

2P conversion adaptor (1)
 (E model)
 1-569-008-12

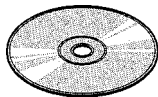

CD-ROM (USB DRIVER) (1)
 (SPVD-010)
 (AEP,UK,E,HK,AUS,
 CH,JE,KR,BR model)
 3-078-942-03
 CD-ROM (USB DRIVER) (1)
 (SPVD-010 (I)) (US,CND model)
 3-078-943-03

HR6 (size AA) Ni-MH
 batteries
 (not supplied)

- Abbreviation
- CND : Canadian model JE : Tourist model
- HK : Hong Kong model KR : Korea model
- AUS : Australian model BR : Brazilian model
- CH : Chinese model

Other accessories

- 3-082-146-11 MANUAL, INSTRUCTION (ENGLISH)
 (US,CND,AEP,UK,E,HK,AUS,CH,JE)
- 3-082-146-21 MANUAL, INSTRUCTION (FRENCH/GERMAN)
 (CND,AEP,JE)
- 3-082-146-31 MANUAL, INSTRUCTION (SPANISH/PORTUGUESE)
 (AEP,E,JE)
- 3-082-146-41 MANUAL, INSTRUCTION (ITALIAN/DUTCH) (AEP)
- 3-082-146-51 MANUAL, INSTRUCTION (CHINESE) (E,HK,CH,JE)
- 3-082-146-61 MANUAL, INSTRUCTION (RUSSIAN/SWEDISH) (AEP,JE)
- 3-082-146-71 MANUAL, INSTRUCTION (ARABIC) (E)
- 3-082-146-81 MANUAL, INSTRUCTION (KOREAN) (KR,JE)

<p>Note : The components identified by mark ▲ or dotted line with mark ▲ are critical for safety. Replace only with part number specified.</p>	<p>Note : Les composants identifiés par une marque ▲ sont critiques pour la sécurité. Ne les remplacer que par une pièce portant le numéro spécifié.</p>
--	--

Revision History

Ver.	Date	History	Contents	S.M. Rev. issued
1.0	2003.03	Official Release	—	—