

DSC-P41/P43

SERVICE MANUAL

LEVEL 2

Ver 1.0 2004.04

Revision History

How to use
Acrobat Reader



Photo: DSC-P43

DSC-P41

US Model

DSC-P43

Hong Kong Model

Tourist Model

Japanese Model

DSC-P41/P43

Canadian Model

AEP Model

UK Model

E Model

Australian Model

Chinese Model

Korea Model

Argentine Model

Brazilian Model

Link

SPECIFICATIONS	BLOCK DIAGRAMS	PRINTED WIRING BOARDS
SERVICE NOTE	FRAME SCHEMATIC DIAGRAM	REPAIR PARTS LIST
DISASSEMBLY	SCHEMATIC DIAGRAMS	

- For ADJUSTMENTS (SECTION 6), refer to SERVICE MANUAL, ADJ (987674351.pdf).
- For INSTRUCTION MANUAL, refer to SERVICE MANUAL, LEVEL 1 (987674341.pdf).
- **Reference No. search on printed wiring boards is available.**
- **HELP: Sheet attachment positions and procedures of processing the flexible boards/harnesses are shown.**

On the CH-146 and SY-101 boards

This service manual provides the information that is premised on the circuit board replacement service and not intended repair inside the CH-146 and SY-101 boards.

Therefore, schematic diagram, printed wiring board and electrical parts list of the CH-146 and SY-101 boards are not shown.

The following pages are not shown.

Schematic diagram	Pages 4-9 to 4-26
Printed wiring board	Pages 4-39 to 4-42
Mounted parts location	Pages 4-50 and 5-51
Electrical parts list	Pages 5-7 and 5-10 to 5-14

The above-described information is shown in service manual Level 3.

DIGITAL STILL CAMERA

SONY®



Cyber-shot



SPECIFICATIONS

■ Camera

[System]

Image device	6.85 mm (1/2.7 type) color CCD Primary color filter
Total pixels number of camera	Approx. 4 231 000 pixels
Effective pixels number of camera	Approx. 4 065 000 pixels
Lens	Fixed focal length lens f=5.0 mm (35 mm camera conversion: 33 mm) F2.8
Exposure control	Automatic, Twilight, Twilight portrait, Candle, Landscape, Beach, Soft snap
White balance	Automatic, Daylight, Cloudy, Fluorescent, Incandescent
File format (DCF compliant)	Still images: Exif Ver. 2.2, JPEG compliant, DPOF compatible Movies: MPEG1 compliant (Monaural)
Recording medium	"Memory Stick"
Flash	Recommended distance (when ISO sensitivity is set to Auto) 0.2 to 3.5 m (7 ⁷ / ₈ inches to 11 feet 5 ⁷ / ₈ inches)

[Input and output connectors]

A/V OUT (MONO) jack (Monaural) (DSC-P43 only)	Minijack Video: 1 Vp-p, 75 Ω, unbalanced, sync negative Audio: 327 mV (at a 47 kΩ load) Output impedance 2.2 kΩ
USB jack	mini-B
USB communication	Hi-Speed USB (USB 2.0 compliant)

[LCD screen]

LCD panel used	3.8 cm (1.5 type) TFT drive
Total number of dots	67 200 (280×240) dots

[Power, general]

Power	AA nickel hydride batteries (2) 2.4 V AA alkaline batteries (2) 3.0 V AC-LS5 AC Adaptor (not supplied), 4.2 V
Power consumption (during shooting with LCD screen on)	1.3 W
Operating temperature range	0° to +40°C (32° to +104°F) (When using alkaline batteries: 5° to +40°C (41° to +104°F))
Storage temperature range	-20° to +60°C (-4° to +140°F)
Dimensions	101.2 × 53.7 × 35.6 mm (4 × 2 ¹ / ₈ × 1 ⁷ / ₁₆ inches) (W/H/D, protruding portions not included)
Mass	Approx. 195 g (0.4 lb 6.9 oz) (two batteries "Memory Stick," wrist strap, and so on included)
Microphone	Electret condenser microphone
Speaker	Dynamic speaker
Exif Print	Compatible
PRINT Image Matching II	Compatible
PictBridge	Compatible

■ BC-CS2A/CS2B Ni-MH battery charger (supplied with the DSC-P43)

Power requirements	AC 100 to 240V 50/60Hz 3 W
Output voltage	AA : DC 1.4 V 400 mA × 2 AAA : DC 1.4 V 160 mA × 2
Operating temperature range	0° to +40°C (32° to +104°F)
Storage temperature range	-20° to +60°C (-4° to +140°F)
Dimensions	71 × 30 × 91 mm (2 ⁷ / ₈ × 1 ³ / ₁₆ × 3 ⁵ / ₈ inches) (W/H/D)
Mass	Approx. 90 g (3 oz)

■ AC-LS5 AC Adaptor (not supplied)

Input rating	AC 100 to 240 V, 50/60 Hz 11 W, 0.16 to 0.09 A
Output rating	DC 4.2 V, 1.5 A
Operating temperature range	0° to +40°C (32° to +104°F)
Storage temperature range	-20° to +60°C (-4° to +140°F)
Dimensions	Approx. 48 × 29 × 81 mm (1 ¹⁵ / ₁₆ × 1 ³ / ₁₆ × 3 ¹ / ₄ inches) (W/H/D, protruding portions not included)
Mass	Approx. 130 g (5 oz)

Accessories

- HR6 (size AA) Ni-MH batteries (2) (DSC-P43 only)
- R6 (size AA) alkaline batteries (2) (DSC-P41 only)
- Battery case (1)
- BC-CS2A/CS2B Ni-MH Battery charger (1) (DSC-P43 only)
- Power cord (mains lead) (1) (DSC-P43 only)
- USB cable (1)
- A/V connecting cable (1) (DSC-P43 only)
- Wrist strap (1)
- "Memory Stick" (16MB) (1)
- CD-ROM (USB driver: SPVD-012) (1)
- Operating Instructions (1)

See page 5-15.

Design and specifications are subject to change without notice.

SAFETY-RELATED COMPONENT WARNING!!

COMPONENTS IDENTIFIED BY MARK \triangle OR DOTTED LINE WITH MARK \triangle ON THE SCHEMATIC DIAGRAMS AND IN THE PARTS LIST ARE CRITICAL TO SAFE OPERATION. REPLACE THESE COMPONENTS WITH SONY PARTS WHOSE PART NUMBERS APPEAR AS SHOWN IN THIS MANUAL OR IN SUPPLEMENTS PUBLISHED BY SONY.

ATTENTION AU COMPOSANT AYANT RAPPORT À LA SÉCURITÉ!

LES COMPOSANTS IDENTIFIÉS PAR UNE MARQUE \triangle SUR LES DIAGRAMMES SCHÉMATIQUES ET LA LISTE DES PIÈCES SONT CRITIQUES POUR LA SÉCURITÉ DE FONCTIONNEMENT. NE REMPLACER CES COMPOSANTS QUE PAR DES PIÈCES SONY DONT LES NUMÉROS SONT DONNÉS DANS CE MANUEL OU DANS LES SUPPLÉMENTS PUBLIÉS PAR SONY.

SAFETY CHECK-OUT

After correcting the original service problem, perform the following safety checks before releasing the set to the customer.

1. Check the area of your repair for unsoldered or poorly-soldered connections. Check the entire board surface for solder splashes and bridges.
2. Check the interboard wiring to ensure that no wires are "pinched" or contact high-wattage resistors.
3. Look for unauthorized replacement parts, particularly transistors, that were installed during a previous repair. Point them out to the customer and recommend their replacement.
4. Look for parts which, through functioning, show obvious signs of deterioration. Point them out to the customer and recommend their replacement.
5. Check the B+ voltage to see it is at the values specified.
6. Flexible Circuit Board Repairing
 - Keep the temperature of the soldering iron around 270°C during repairing.
 - Do not touch the soldering iron on the same conductor of the circuit board (within 3 times).
 - Be careful not to apply force on the conductor when soldering or unsoldering.

Unleaded solder

Boards requiring use of unleaded solder are printed with the lead-free mark (LF) indicating the solder contains no lead. (Caution: Some printed circuit boards may not come printed with the lead free mark due to their particular size.)

**: LEAD FREE MARK**

Unleaded solder has the following characteristics.

- Unleaded solder melts at a temperature about 40°C higher than ordinary solder. Ordinary soldering irons can be used but the iron tip has to be applied to the solder joint for a slightly longer time. Soldering irons using a temperature regulator should be set to about 350°C. Caution: The printed pattern (copper foil) may peel away if the heated tip is applied for too long, so be careful!
- Strong viscosity. Unleaded solder is more viscous (sticky, less prone to flow) than ordinary solder so use caution not to let solder bridges occur such as on IC pins, etc.
- Usable with ordinary solder. It is best to use only unleaded solder but unleaded solder may also be added to ordinary solder.

TABLE OF CONTENTS

<u>Section</u>	<u>Title</u>	<u>Page</u>
1.	SERVICE NOTE	
1-1.	Note for Repair	1-1
1-2.	Discharging of the ST-098 Board's Charging Capacitor (C852)	1-1
1-3.	Description on Self-diagnosis Display	1-2
2.	DISASSEMBLY	
2-1.	Flow Chart	2-1
2-2.	SY-101 Board Service Position	2-3
2-3.	Circuit Boards Location	2-5
2-4.	Flexible Boards Location	2-5
3.	BLOCK DIAGRAMS	
3-1.	Overall Block Diagram (1/2)	3-1
3-2.	Overall Block Diagram (2/2)	3-3
3-3.	Power Block Diagram (1/2)	3-5
3-4.	Power Block Diagram (2/2)	3-7
4.	PRINTED WIRING BOARDS AND SCHEMATIC DIAGRAMS	
4-1.	Frame Schematic Diagram	4-1
4-2.	Schematic Diagrams	4-5
	CD-501 (CCD IMAGER)	4-7
	SW-420 (CONTROL SWITCH, LCD DRIVE)	4-27
	ST-098 (FLASH DRIVE)	4-29
	MS (FP-861 FLEXIBLE) (MEMORY STICK CONNECTOR)	4-31
	FP-860 FLEXIBLE (JACK)	4-32
	MICROPHONE UNIT (MA-001)	4-33
	CONTROL SWITCH BLOCK (RL51510)	4-34
4-3.	Printed Wiring Boards	4-35
	CD-501	4-37
	SW-420	4-43
	ST-098	4-45
	MS (FP-861 FLEXIBLE)	4-47
	FP-860 FLEXIBLE	4-48
4-4.	Mounted Parts Location	4-49
5.	REPAIR PARTS LIST	
5-1.	Exploded Views	5-2
5-1-1.	Front Cabinet Block Section	5-2
5-1-2.	Lens Block Section	5-3
5-1-3.	BT Holder Block Section	5-4
5-1-4.	Rear Cabinet Block Section	5-5
5-2.	Electrical Parts List	5-6

SECTION 1 SERVICE NOTE

1-1. NOTE FOR REPAIR

Make sure that the flat cable and flexible board are not cracked or bent at the terminal.
Do not insert the cable insufficiently nor crookedly.

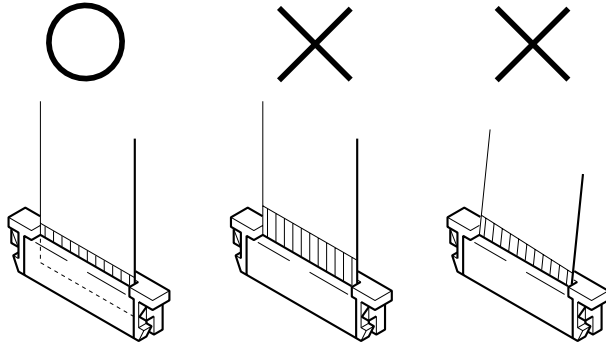

When remove a connector, don't pull at wire of connector.
It is possible that a wire is snapped.

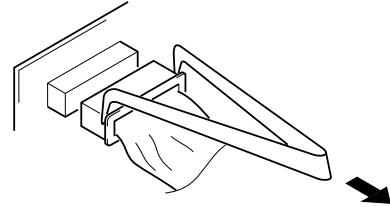

When installing a connector, don't press down at wire of connector.
It is possible that a wire is snapped.

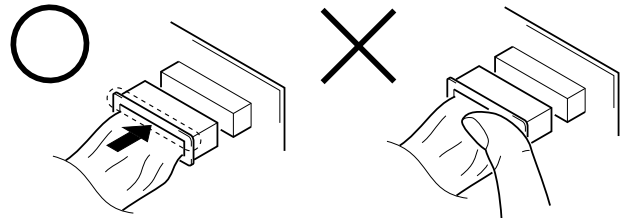

Cut and remove the part of gilt which comes off at the point.
(Be careful or some pieces of gilt may be left inside)

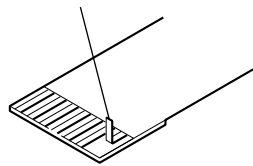

1-2. DISCHARGING OF THE ST-098 BOARD'S CHARGING CAPACITOR (C852)

The charging capacitor (C852) of the ST-098 board is charged up to the maximum 300 V potential.

There is a danger of electric shock by this high voltage when the capacitor is handled by hand. The electric shock is caused by the charged voltage which is kept without discharging when the main power of the unit is simply turned off. Therefore, the remaining voltage must be discharged as described below.

Preparing the Short Jig

To preparing the short jig, a small clip is attached to each end of a resistor of 1 k Ω / 1 W (1-215-869-11).
Wrap insulating tape fully around the leads of the resistor to prevent electrical shock.

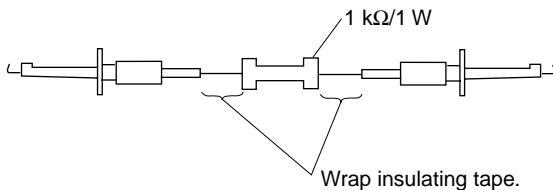

Discharging the Capacitor

Short-circuit between the positive and the negative terminals of charged capacitor with the short jig about 10 seconds.

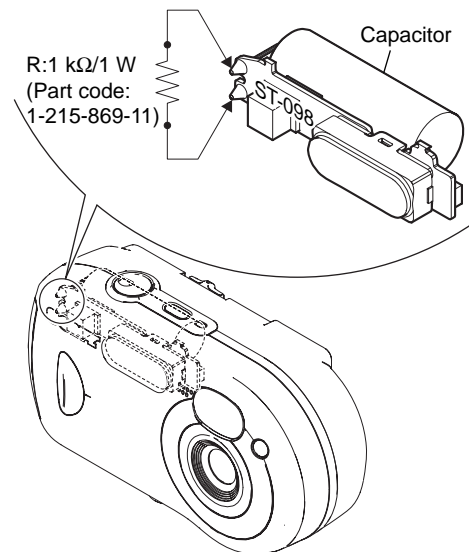

1-3. DESCRIPTION ON SELF-DIAGNOSIS DISPLAY

Self-diagnosis display

The camera has a self-diagnosis display. This function displays the camera condition with five-digits (a combination of a letter and figures) on the LCD screen. If this occurs check the following code chart. The five-digits display informs you of the camera's current condition. The last two digits (indicated by □□) will differ depending on the state of the camera.

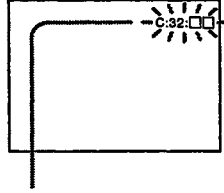

Self-diagnosis display

- C: □□: □□

You can reverse the camera malfunction yourself. (However, contact your Sony dealer or local authorized Sony service facility when you cannot recover from the camera malfunction.)

- E: □□: □□

Contact your Sony dealer or local authorized Sony service facility.

Display Code	Countermeasure	Cause	Caution Display During Error
C:32:□□	Turn the power off and on again.	Trouble with hardware.	SYSTEM ERROR
C:13:□□	Format the "Memory stick".	Unformatted memory stick is inserted.	FORMAT ERROR
	Insert a new "Memory Stick".	Memory stick is broken.	MEMORY STICK ERROR
E:61:□□	Checking of lens drive circuit.	When failed in the focus and zoom initialization.	—
E:91:□□	Checking of flash unit or replacement of flash unit.	Abnormality when flash is being charged.	
E:92:□□	Insert batteries correctly.	Batteries are not inserted correctly.	
	Turn the power off and on again.	Batteries were installed or removed when using the AC adaptor.	



SECTION 2 DISASSEMBLY

2-1. FLOW CHART

The following flow chart shows the disassembly procedure.

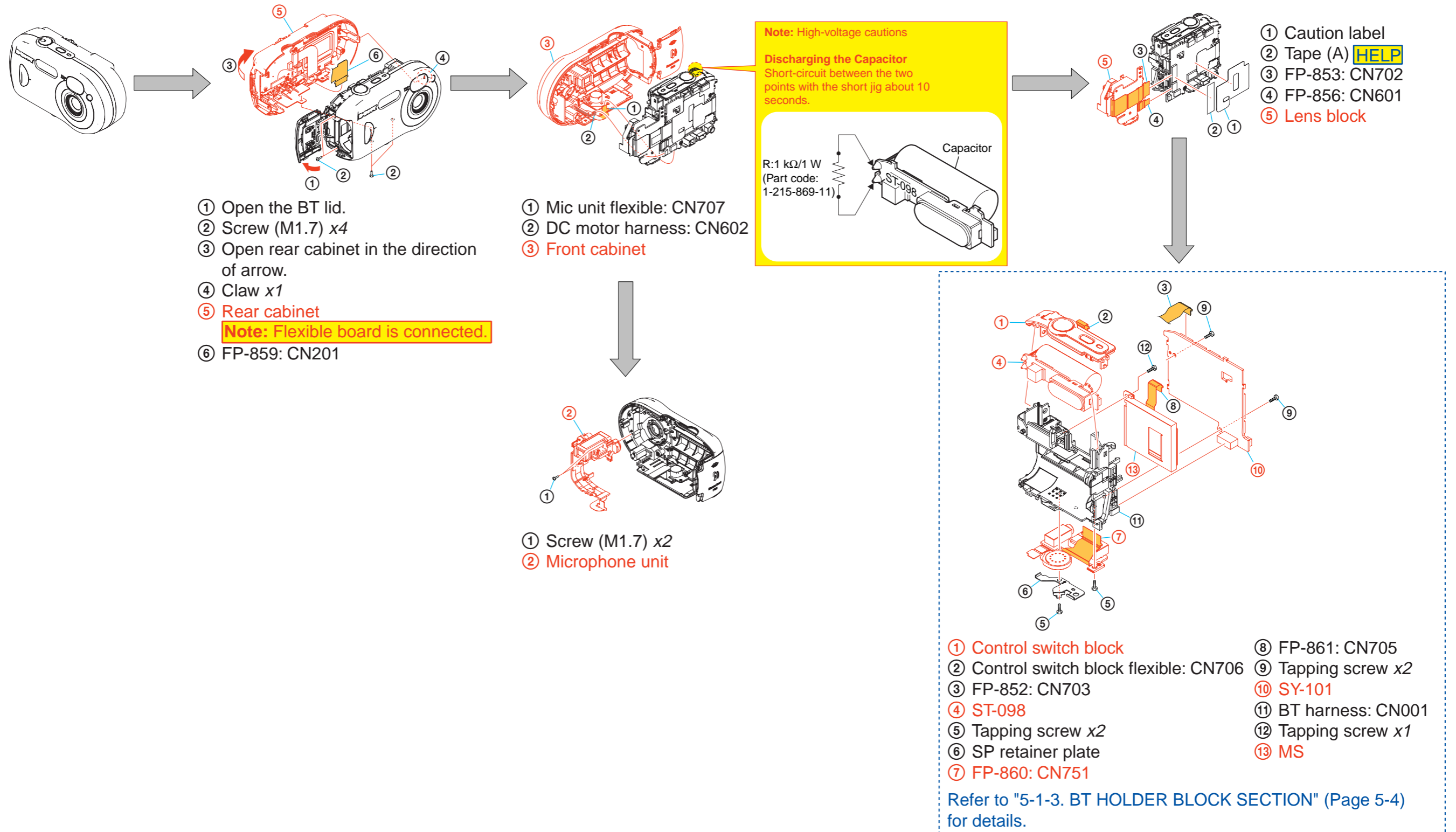

2-2. SY-101 BOARD SERVICE POSITION

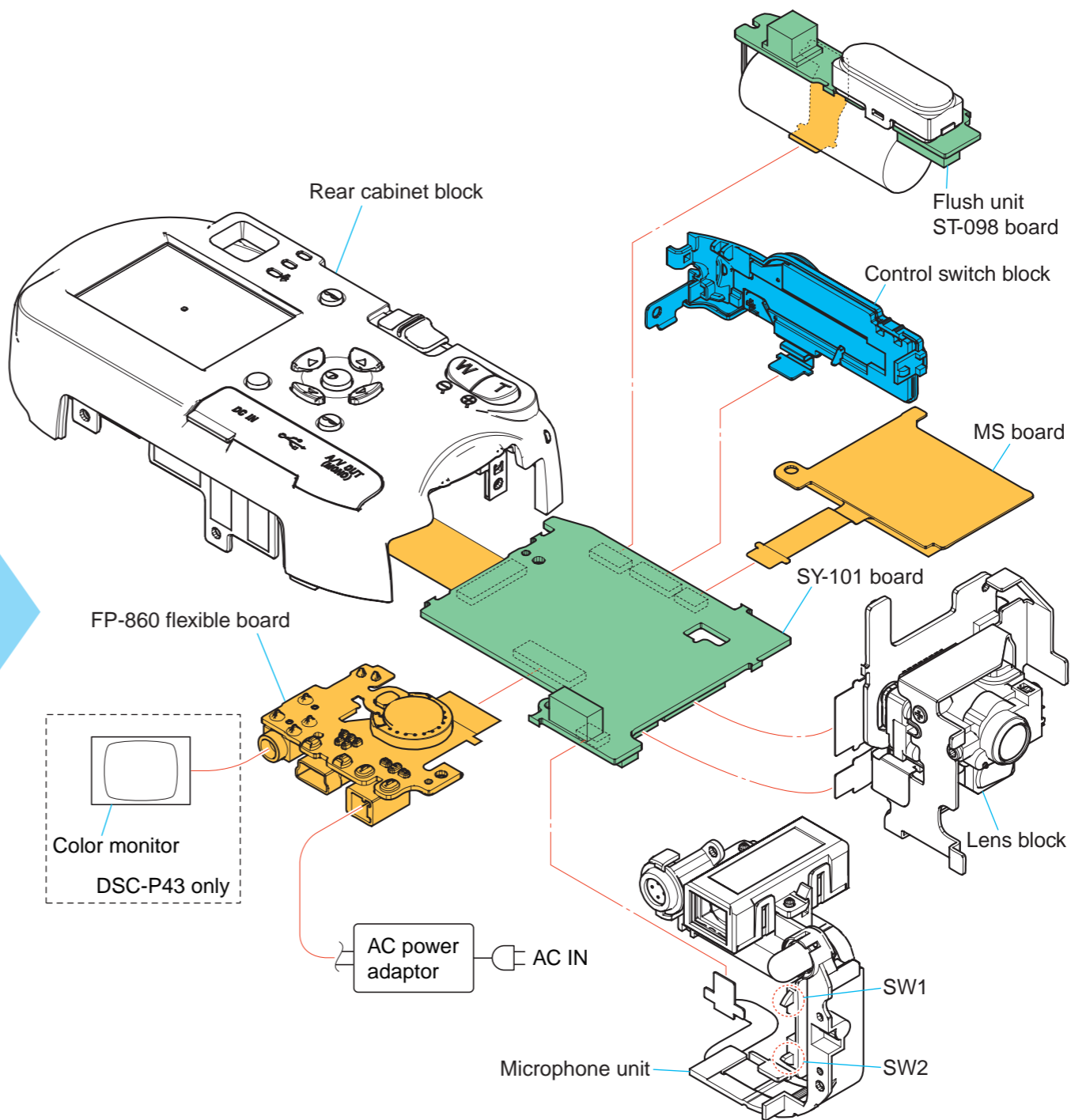
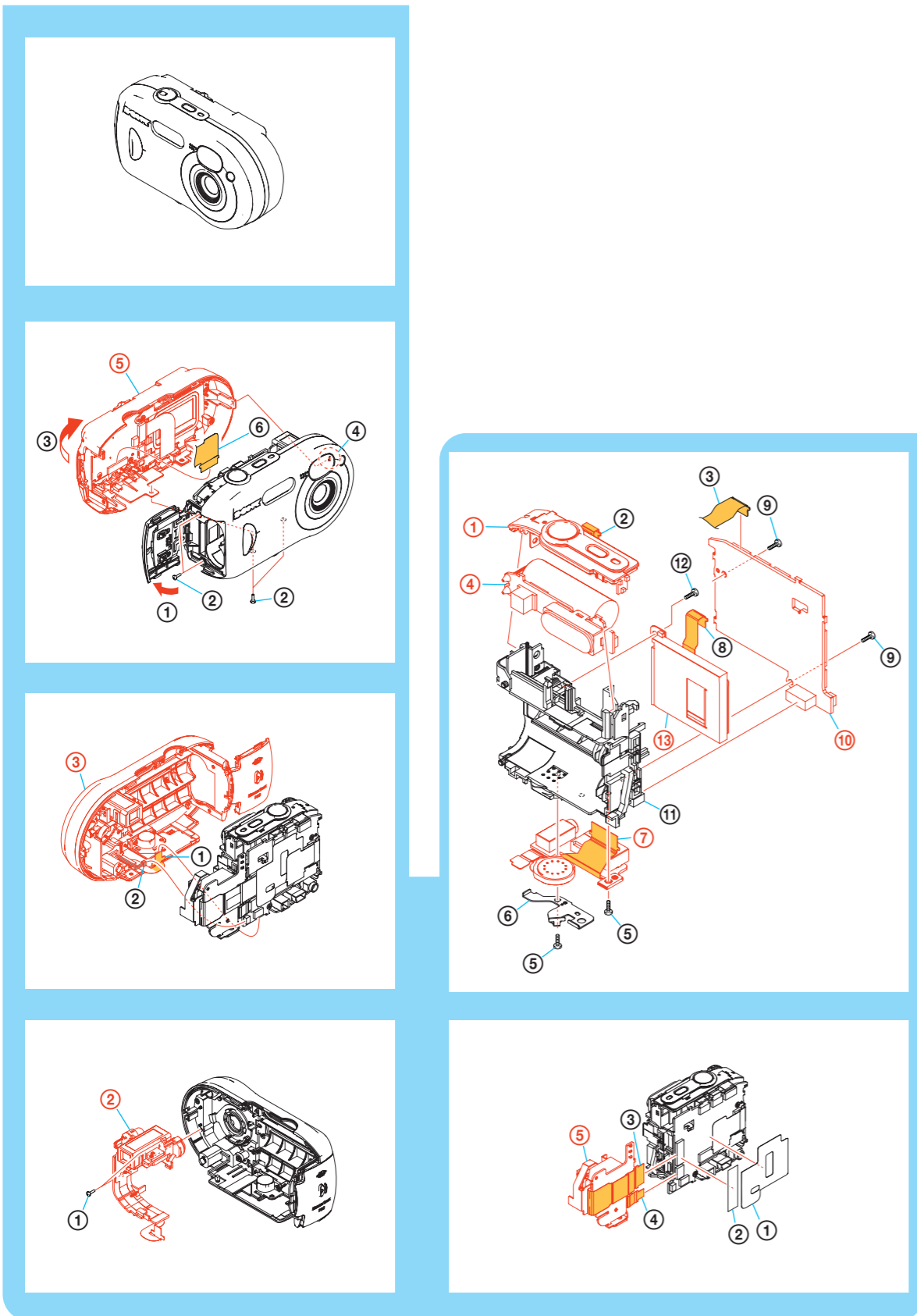

Setting the "STILL" or "MOVIE" mode

Before turn on the power, you have to keep a switch (SW1) pushed in order to maintain the "STILL" or "MOVIE" mode.

Setting the "VIEW" mode

Before turn on the power, you have to keep a switch (SW2) pushed in order to maintain the "VIEW" mode.

2-3. CIRCUIT BOARDS LOCATION

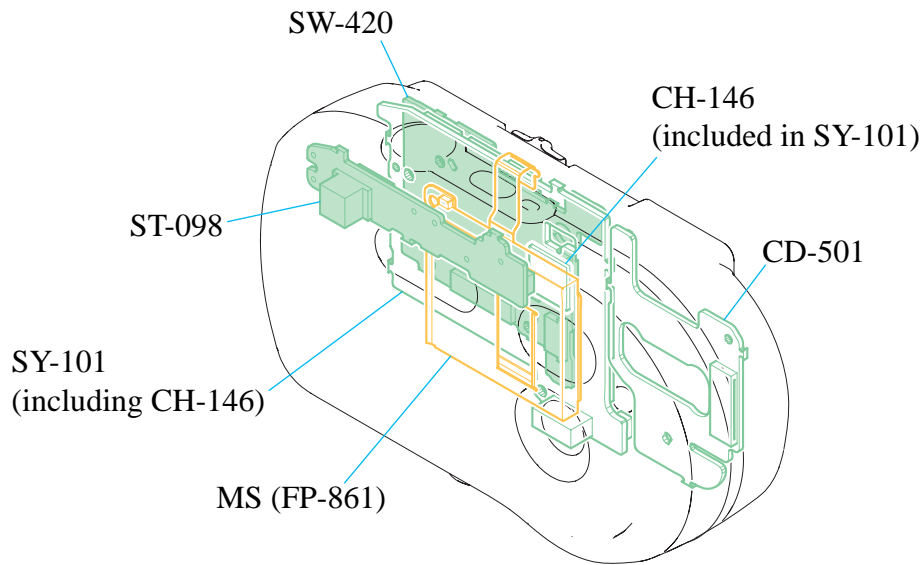

Board Name	Function
CD-501	CCD IMAGER
CH-146 (included in SY-101)	CCD SIGNAL PROCESS
MS (FP-861)	MEMORY STICK CONNECTOR
ST-098	FLASH DRIVE
SW-420	CONTROL SWITCH, LCD DRIVE
SY-101 (Including CH-146)	CAMERA MODULE, CAMERA DSP, LENS DRIVE, SH DSP, FRONT CONTROL, AUDIO, DC/DC CONVERTER

2-4. FLEXIBLE BOARDS LOCATION

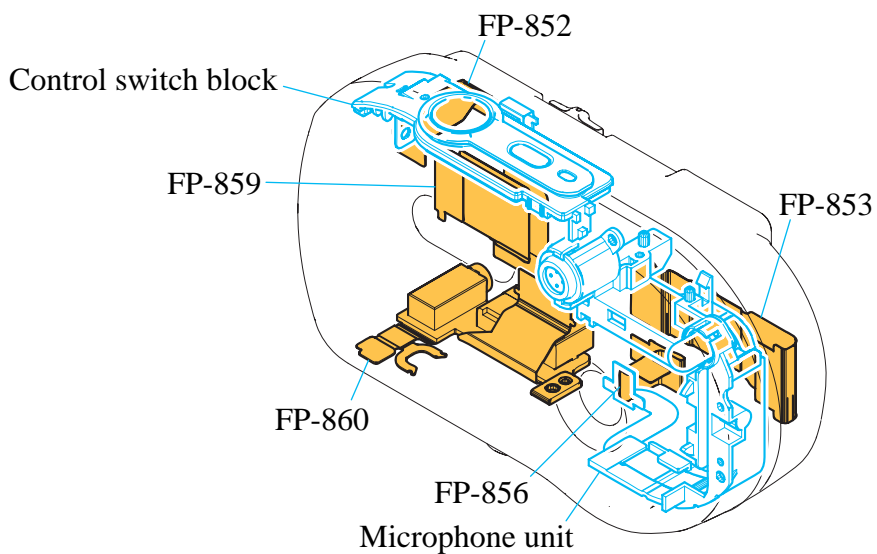

HELP

Sheet attachment positions and procedures of processing the flexible boards/harnesses are shown.

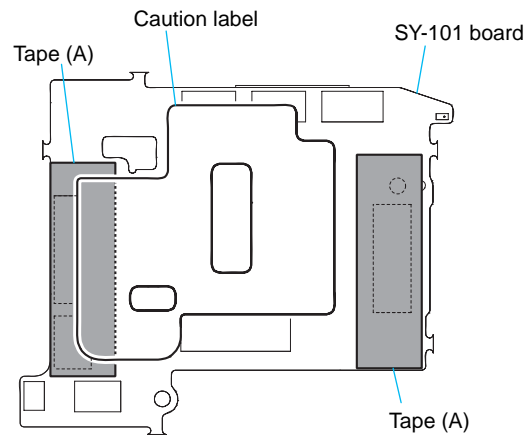

3. BLOCK DIAGRAMS

Link

• [OVERALL BLOCK DIAGRAM \(1/2\)](#)

• [POWER BLOCK DIAGRAM \(1/2\)](#)

• [OVERALL BLOCK DIAGRAM \(2/2\)](#)

• [POWER BLOCK DIAGRAM \(2/2\)](#)

3. BLOCK DIAGRAMS

3-2. OVERALL BLOCK DIAGRAM (2/2) () : Number in parenthesis () indicates the division number of schematic diagram where the component is located.

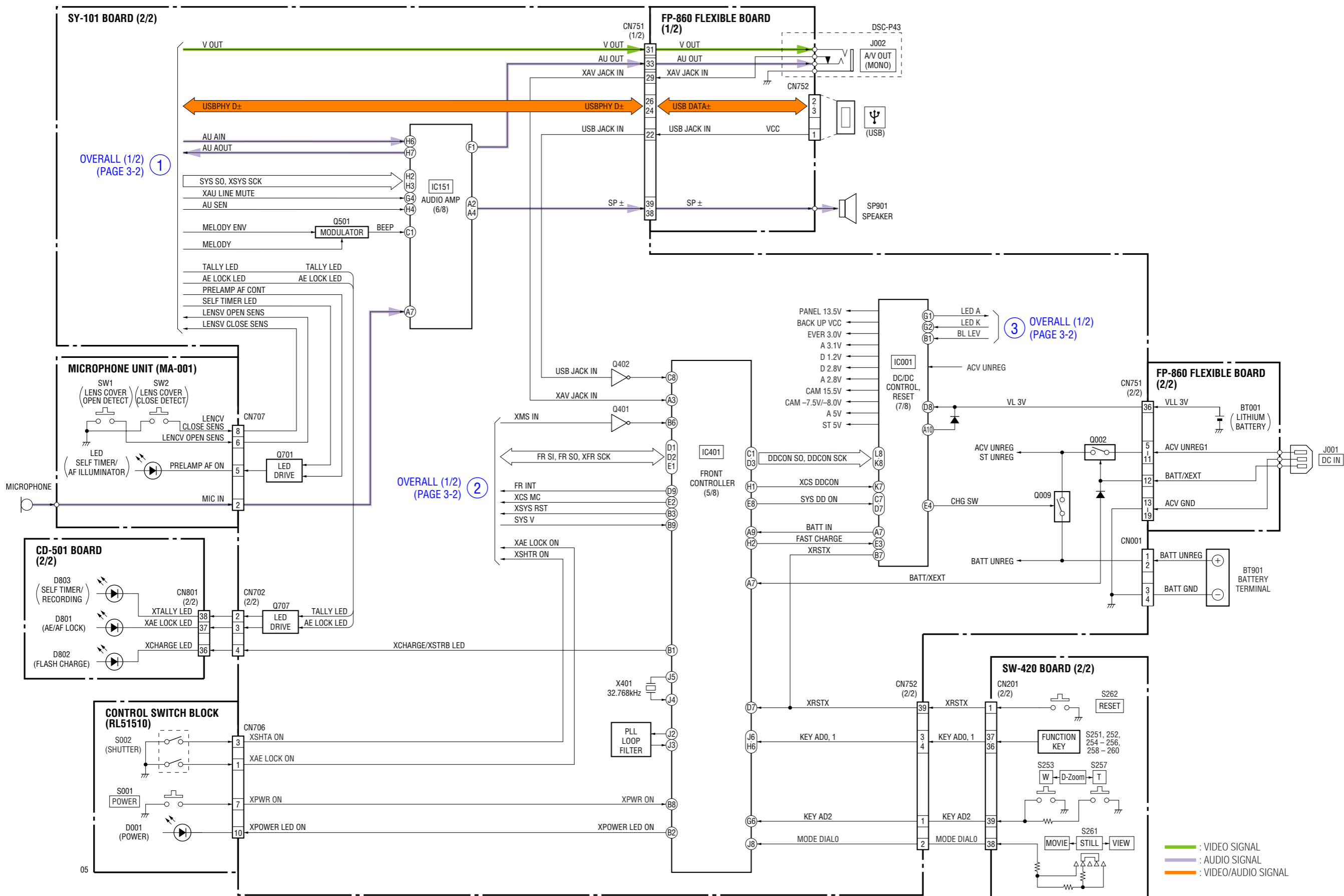

3. BLOCK DIAGRAMS

3-3. POWER BLOCK DIAGRAM (1/2) () : Number in parenthesis () indicates the division number of schematic diagram where the component is located.

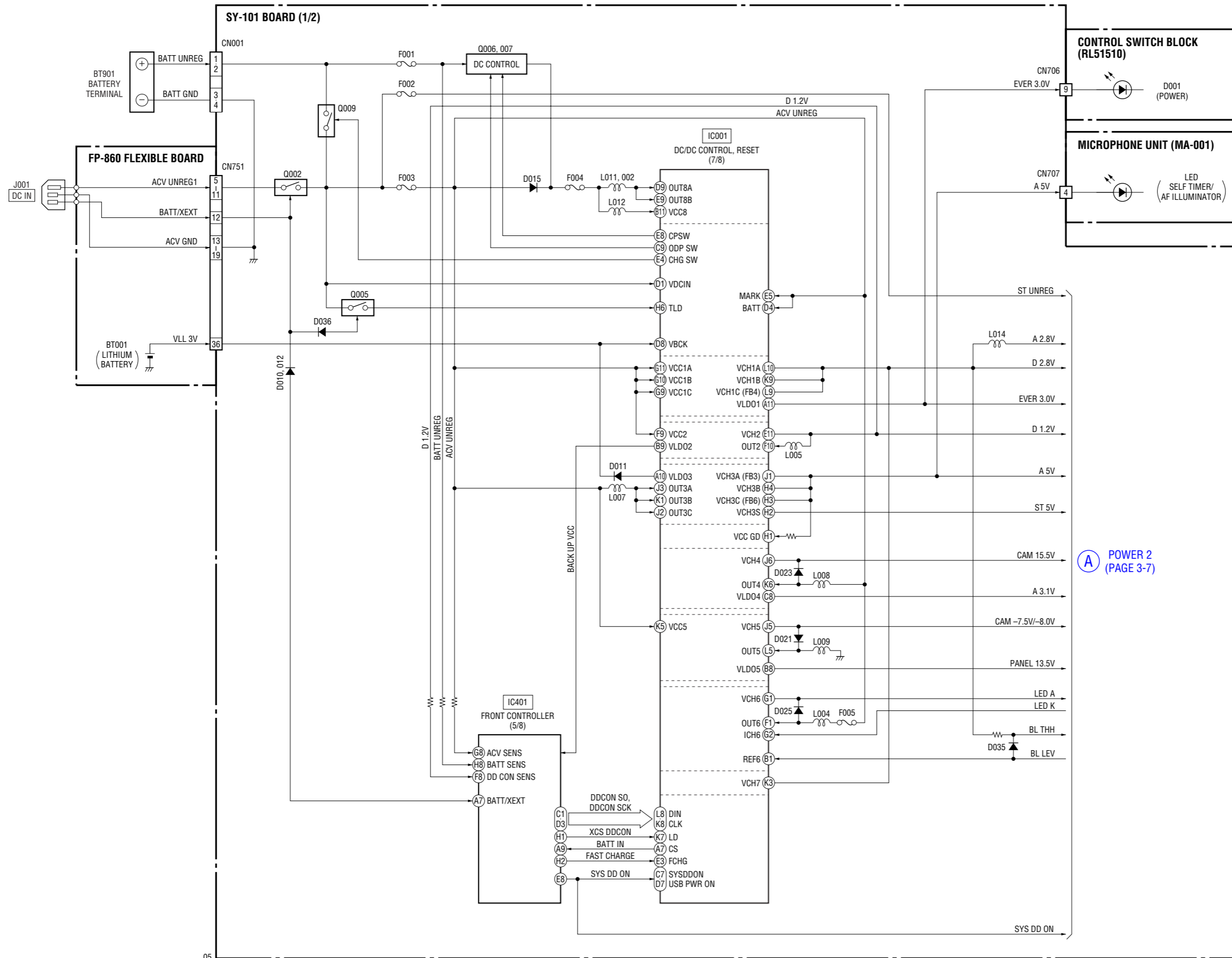

(A) POWER 2 (PAGE 3-7)

3. BLOCK DIAGRAMS

3-4. POWER BLOCK DIAGRAM (2/2) () : Number in parenthesis () indicates the division number of schematic diagram where the component is located.

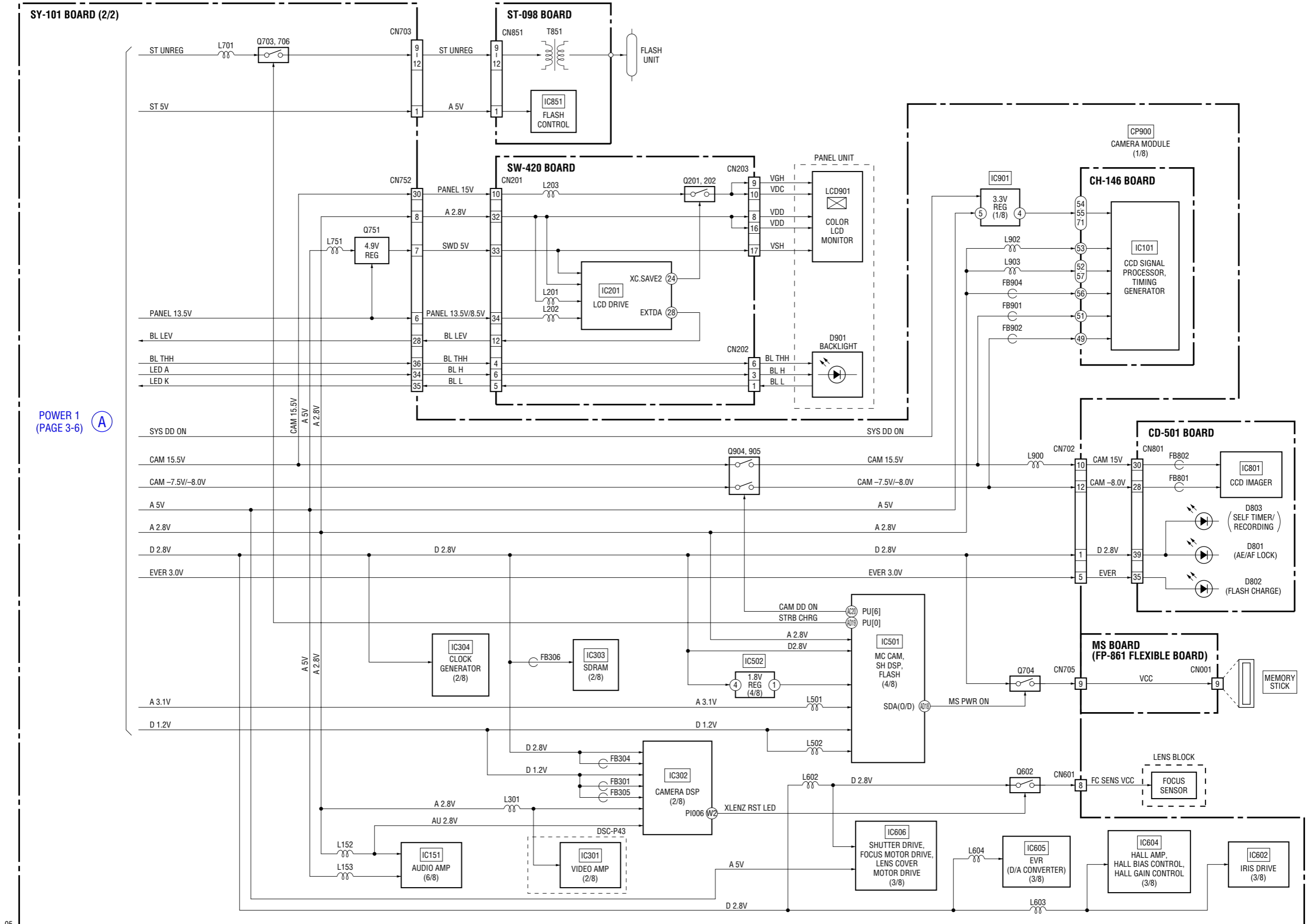

POWER 1 (PAGE 3-6) (A)

SECTION 4

PRINTED WIRING BOARDS AND SCHEMATIC DIAGRAMS

4-1. FRAME SCHEMATIC DIAGRAM

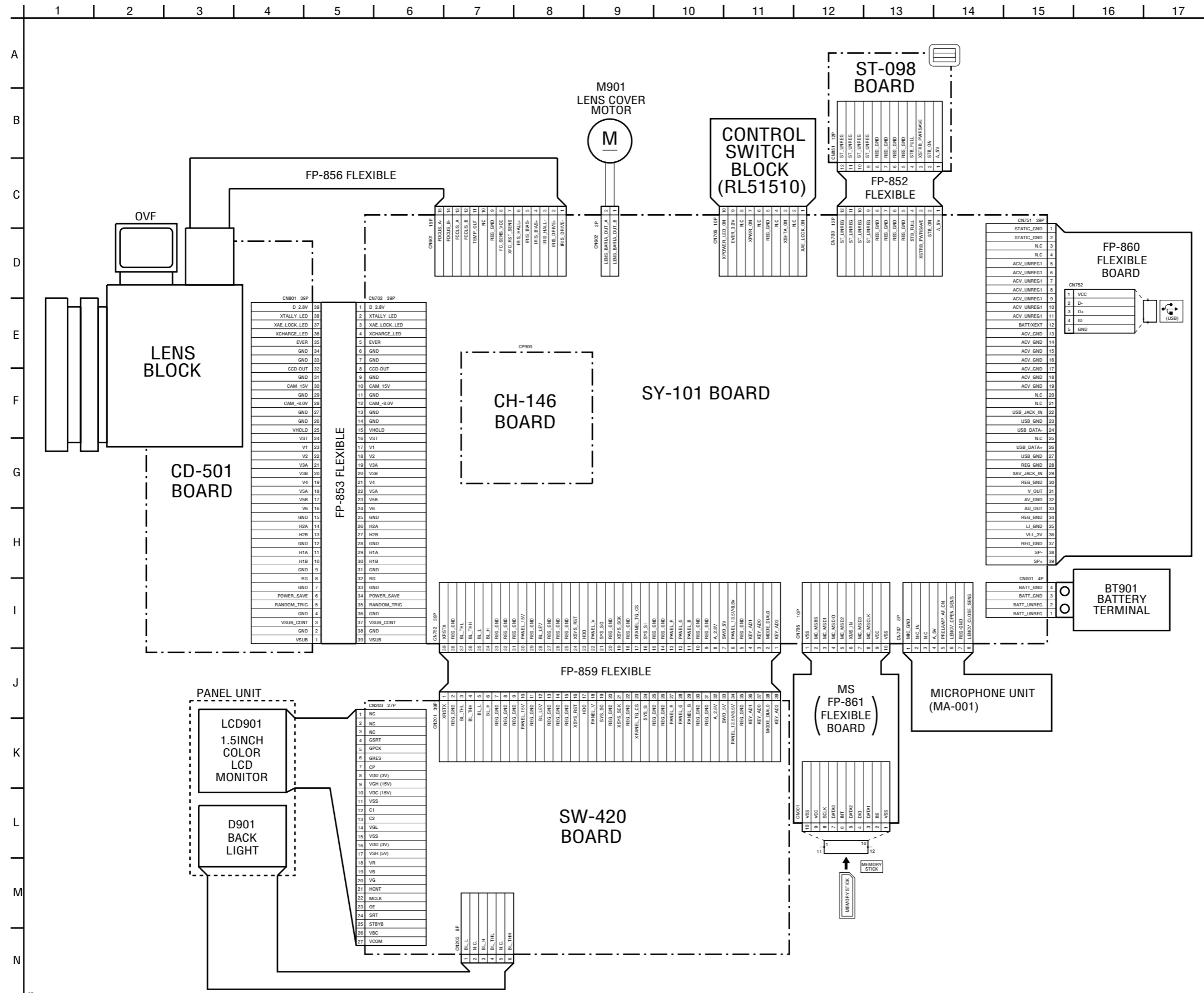

4-2. SCHEMATIC DIAGRAMS

Link

<ul style="list-style-type: none">• CD-501 BOARD (CCD IMAGER)	<ul style="list-style-type: none">• FP-860 FLEXIBLE BOARD (JACK)
<ul style="list-style-type: none">• SW-420 BOARD (CONTROL SWITCH, LCD DRIVE)	<ul style="list-style-type: none">• MICROPHONE UNIT (MA-001)
<ul style="list-style-type: none">• ST-098 BOARD (FLASH DRIVE)	<ul style="list-style-type: none">• CONTROL SWITCH BLOCK (RL51510)
<ul style="list-style-type: none">• MS BOARD (FP-861 FLEXIBLE BOARD) (MEMORY STICK CONNECTOR)	
<ul style="list-style-type: none">• COMMON NOTE FOR SCHEMATIC DIAGRAMS	

4-2. SCHEMATIC DIAGRAMS









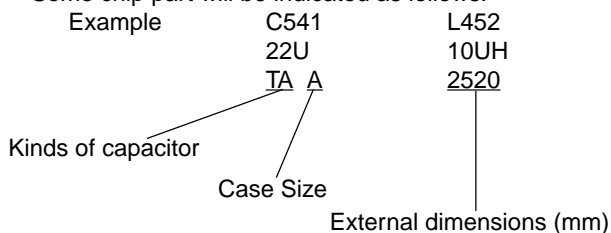



4-2. SCHEMATIC DIAGRAMS

THIS NOTE IS COMMON FOR SCHEMATIC DIAGRAMS
 (In addition to this, the necessary note is printed in each block)

(For schematic diagrams)

- All capacitors are in μF unless otherwise noted. pF : μ μF . 50 V or less are not indicated except for electrolytics and tantalums.
- Chip resistors are 1/10 W unless otherwise noted. $\text{k}\Omega=1000 \Omega$, $\text{M}\Omega=1000 \text{k}\Omega$.
- Caution when replacing chip parts. New parts must be attached after removal of chip. Be careful not to heat the minus side of tantalum capacitor, Because it is damaged by the heat.
- Some chip part will be indicated as follows.



- Constants of resistors, capacitors, ICs and etc with XX indicate that they are not used. In such cases, the unused circuits may be indicated.
- Parts with \star differ according to the model/destination. Refer to the mount table for each function.
- All variable and adjustable resistors have characteristic curve B, unless otherwise noted.
- Signal name
 $\text{XEDIT} \rightarrow \overline{\text{EDIT}}$ $\text{PB/XREC} \rightarrow \overline{\text{PB/REC}}$
-  : non flammable resistor
-  : fusible resistor
-  : panel designation
-  : B+ Line
-  : B- Line
-  : IN/OUT direction of (+,-) B LINE.
-  : adjustment for repair.
-  : VIDEO SIGNAL (ANALOG)
-  : AUDIO SIGNAL (ANALOG)
-  : VIDEO/AUDIO SIGNAL
-  : VIDEO/AUDIO/SERVO SIGNAL
-  : SERVO SIGNAL
- Circled numbers refer to waveforms.

(Measuring conditions voltage and waveform)

- Voltages and waveforms are measured between the measurement points and ground when camera shoots color bar chart of pattern box. They are reference values and reference waveforms.
 (VOM of DC 10 $\text{M}\Omega$ input impedance is used)
- Voltage values change depending upon input impedance of VOM used.)

Note : The components identified by mark \triangle or dotted line with mark \triangle are critical for safety. Replace only with part number specified.

1. Connection

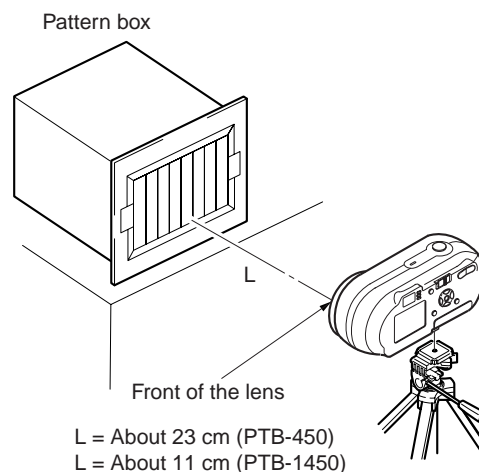

2. Adjust the distance so that the display of Fig. a can be obtain.

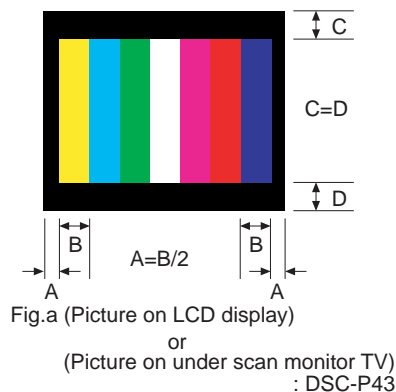

When indicating parts by reference number, please include the board name.

Note : Les composants identifiés par une marque \triangle sont critiques pour la sécurité. Ne les remplacer que par une pièce portant le numéro spécifiée.

For Schematic Diagram

• Refer to page 4-37 for printed wiring board.

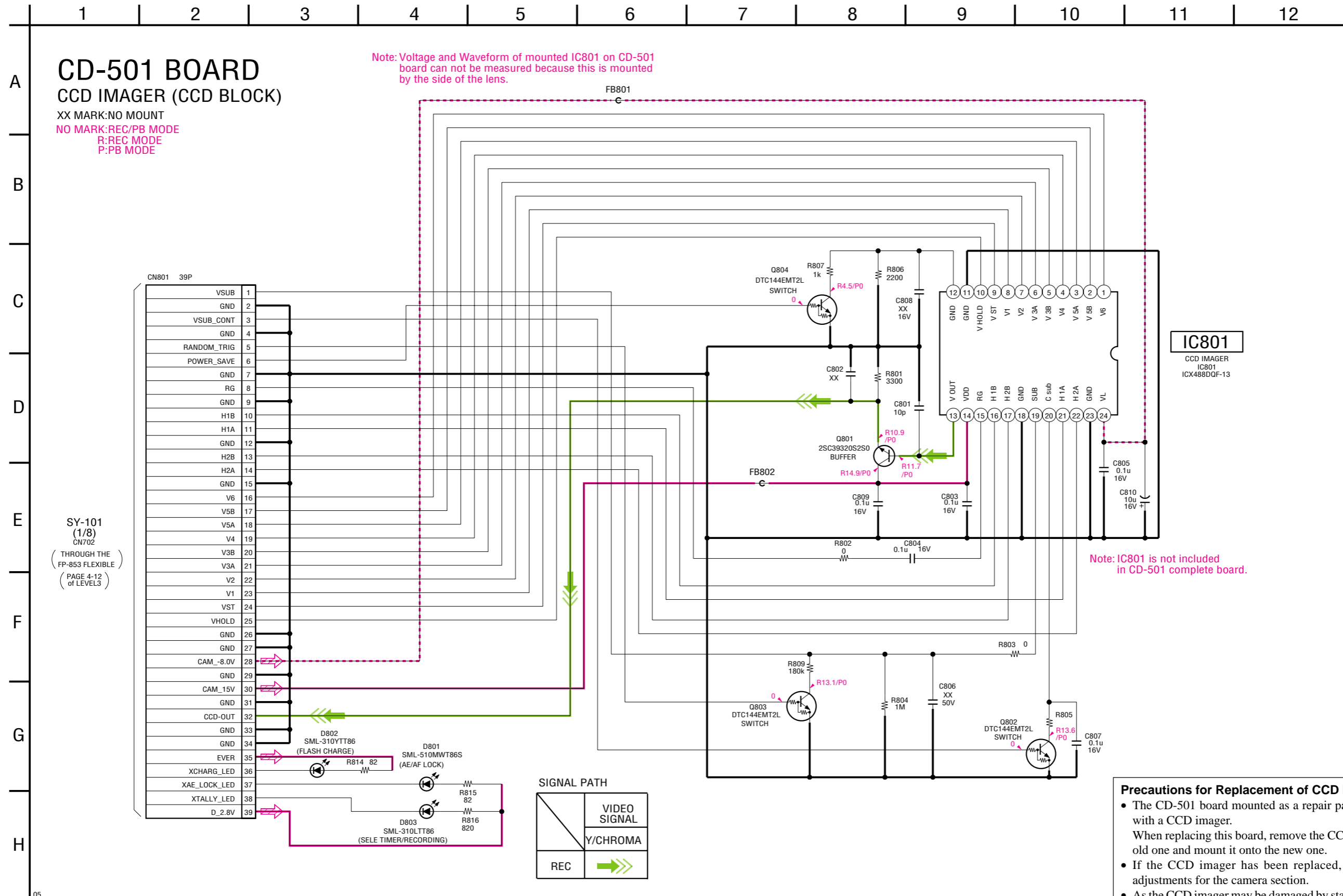

Precautions for Replacement of CCD Imager

- The CD-501 board mounted as a repair part is not equipped with a CCD imager. When replacing this board, remove the CCD imager from the old one and mount it onto the new one.
- If the CCD imager has been replaced, carry out all the adjustments for the camera section.
- As the CCD imager may be damaged by static electricity from its structure, handle it carefully like for the MOS IC. In addition, ensure that the receiver is not covered with dusts nor exposed to strong light.

Schematic diagrams of the CH-146 and SY-101 boards are not shown.
Pages from 4-9 to 4-26 are not shown.

4-2. SCHEMATIC DIAGRAMS SW-420 BOARD

For Schematic Diagram
 • Refer to page 4-43 for printed wiring board.

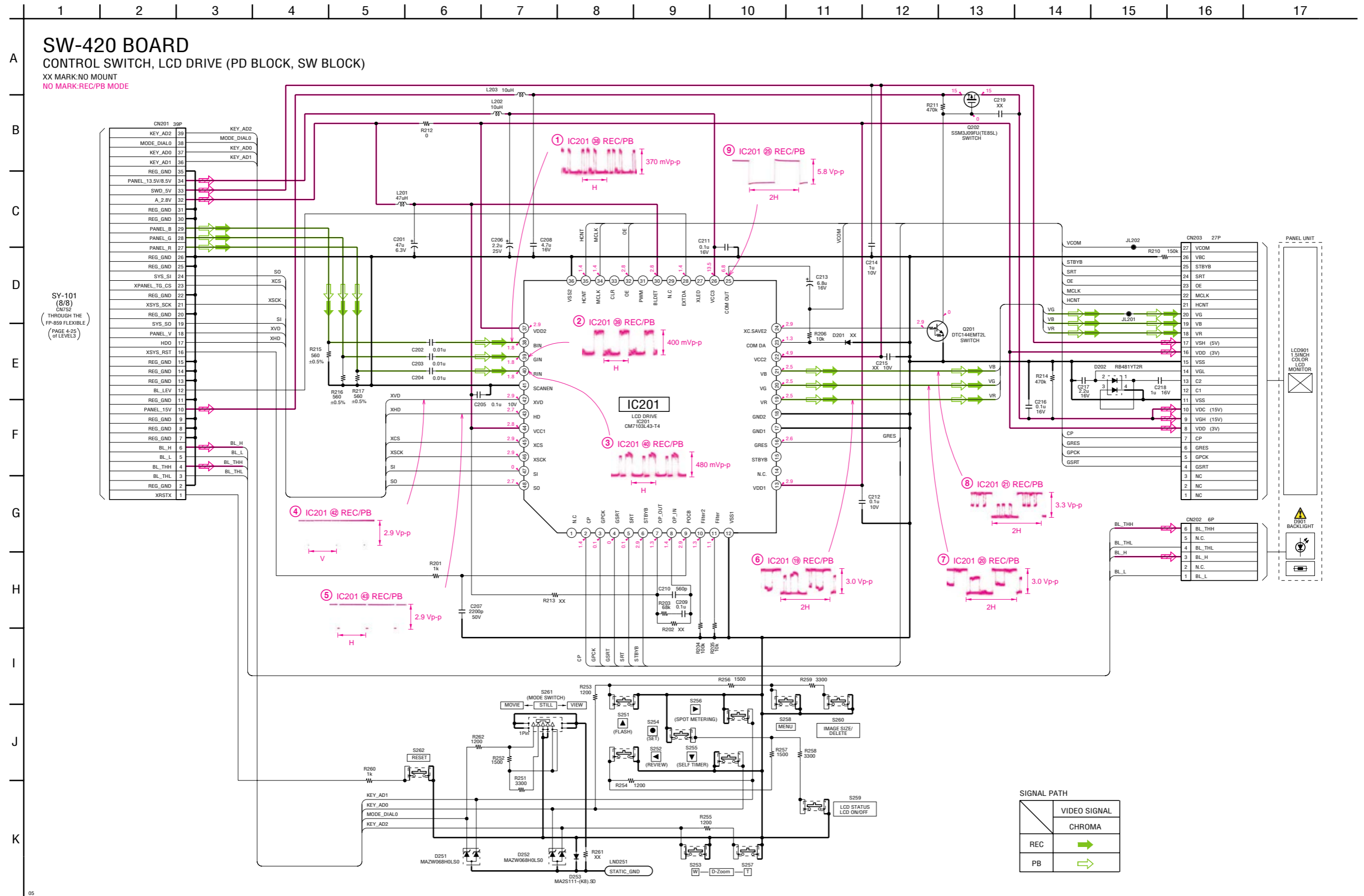

The components identified by mark Δ or dotted line with mark Δ are critical for safety. Replace only with part number specified.

Les composants identifiés par une marque Δ sont critiques pour la sécurité. Ne les remplacer que par une pièce portant le numéro spécifié.

4-2. SCHEMATIC DIAGRAMS ST-098 BOARD

For Schematic Diagram
 • Refer to page 4-45 for printed wiring board.

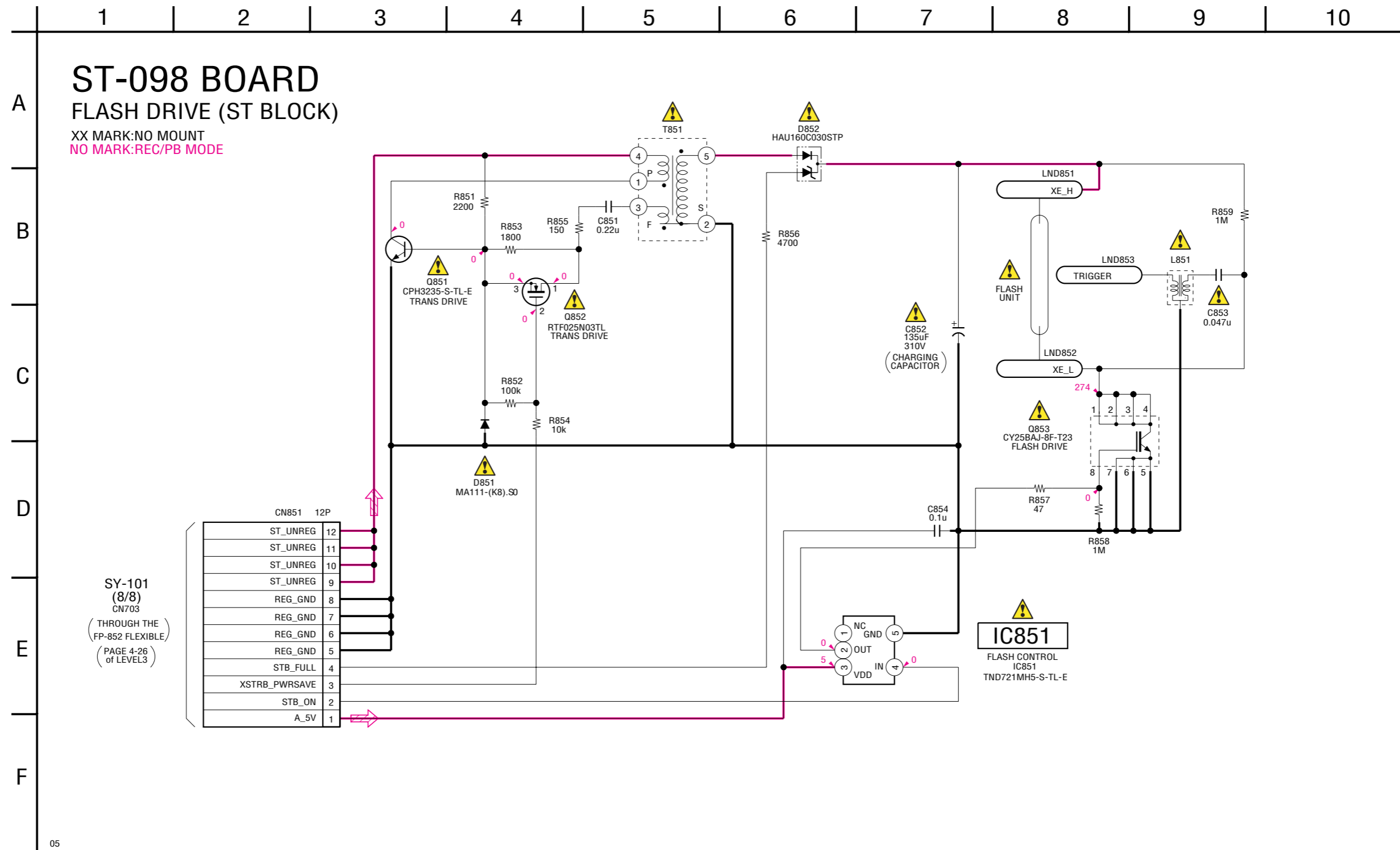

The components identified by mark \triangle or dotted line with mark \triangle are critical for safety. Replace only with part number specified.

Les composants identifiés par une marque \triangle sont critiques pour la sécurité. Ne les remplacer que par une pièce portant le numéro spécifié.

For Schematic Diagram

• Refer to page 4-47 for printed wiring board.

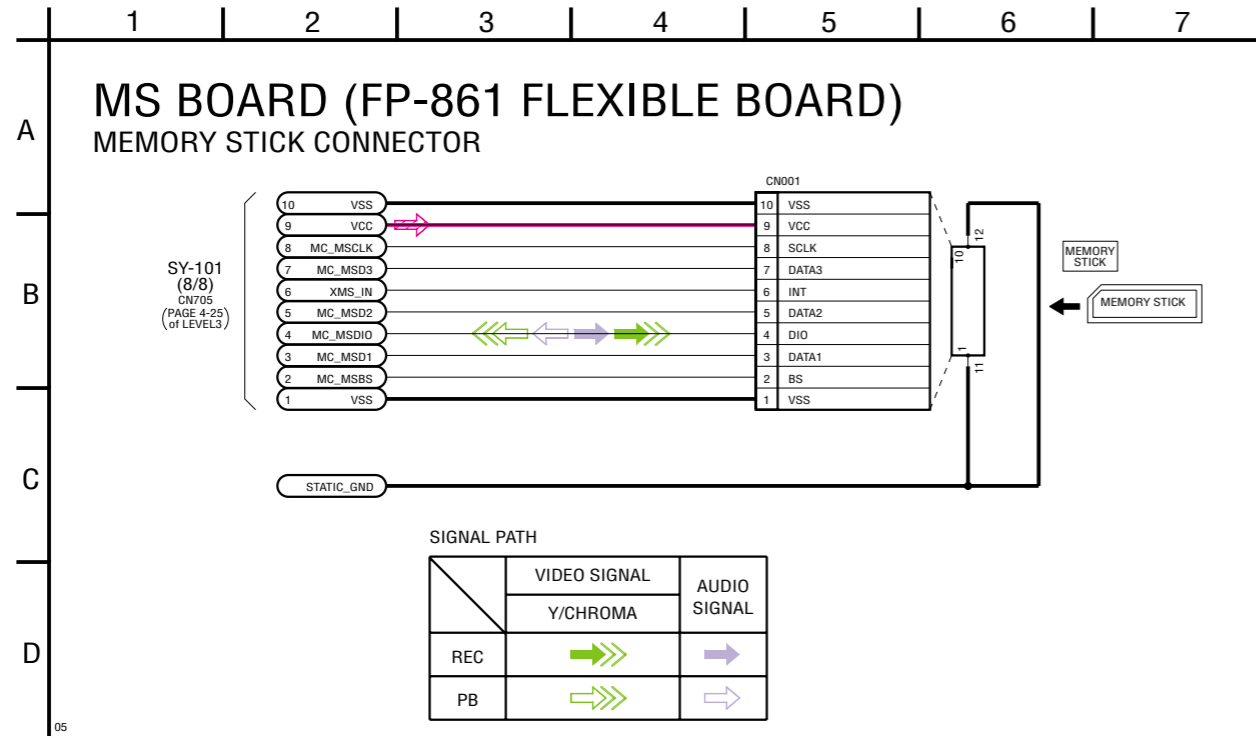

For Schematic Diagram

• Refer to page 4-48 for printed wiring board.

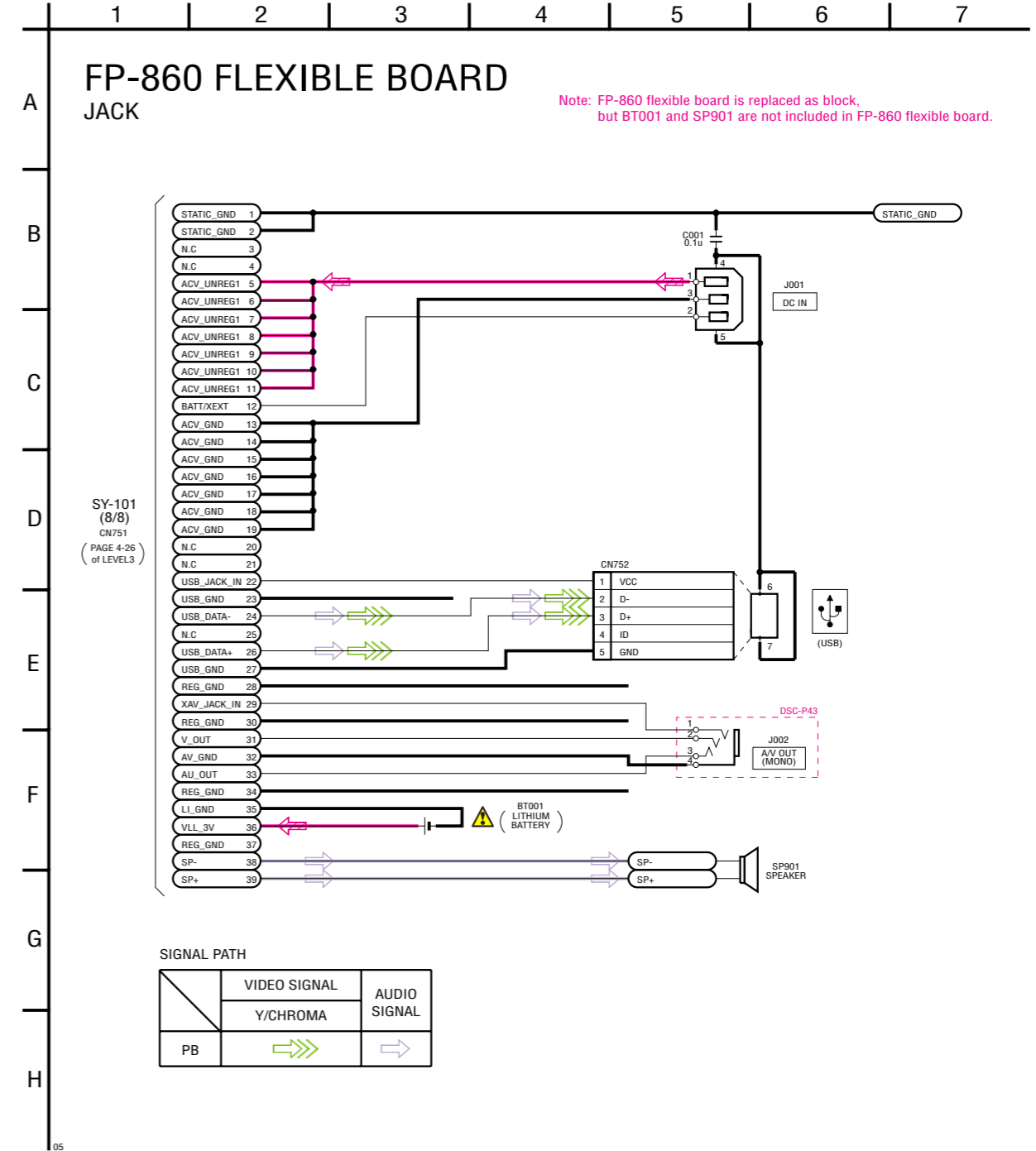

The components identified by mark \triangle or dotted line with mark \triangle are critical for safety. Replace only with part number specified.

Les composants identifiés par une marque \triangle sont critiques pour la sécurité. Ne les remplacer que par une pièce portant le numéro spécifié.

4-2. SCHEMATIC DIAGRAMS

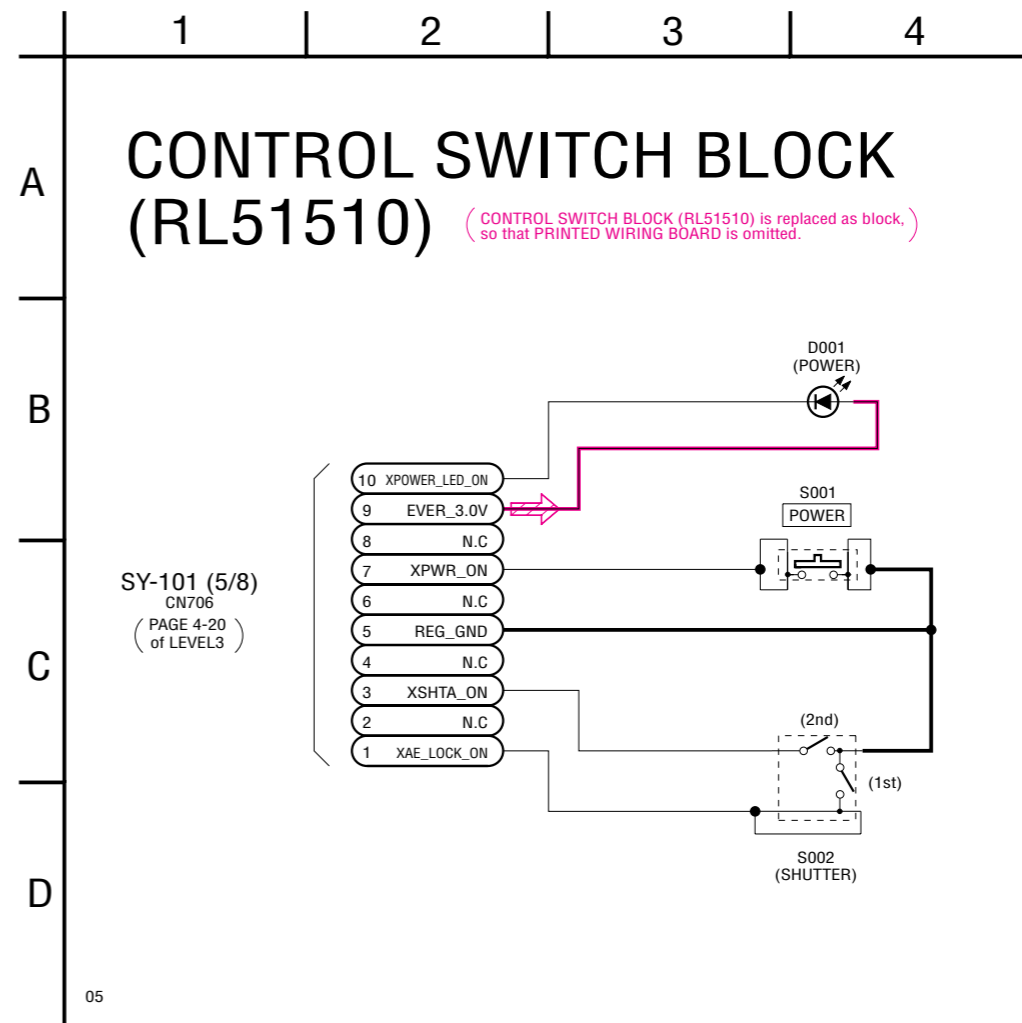
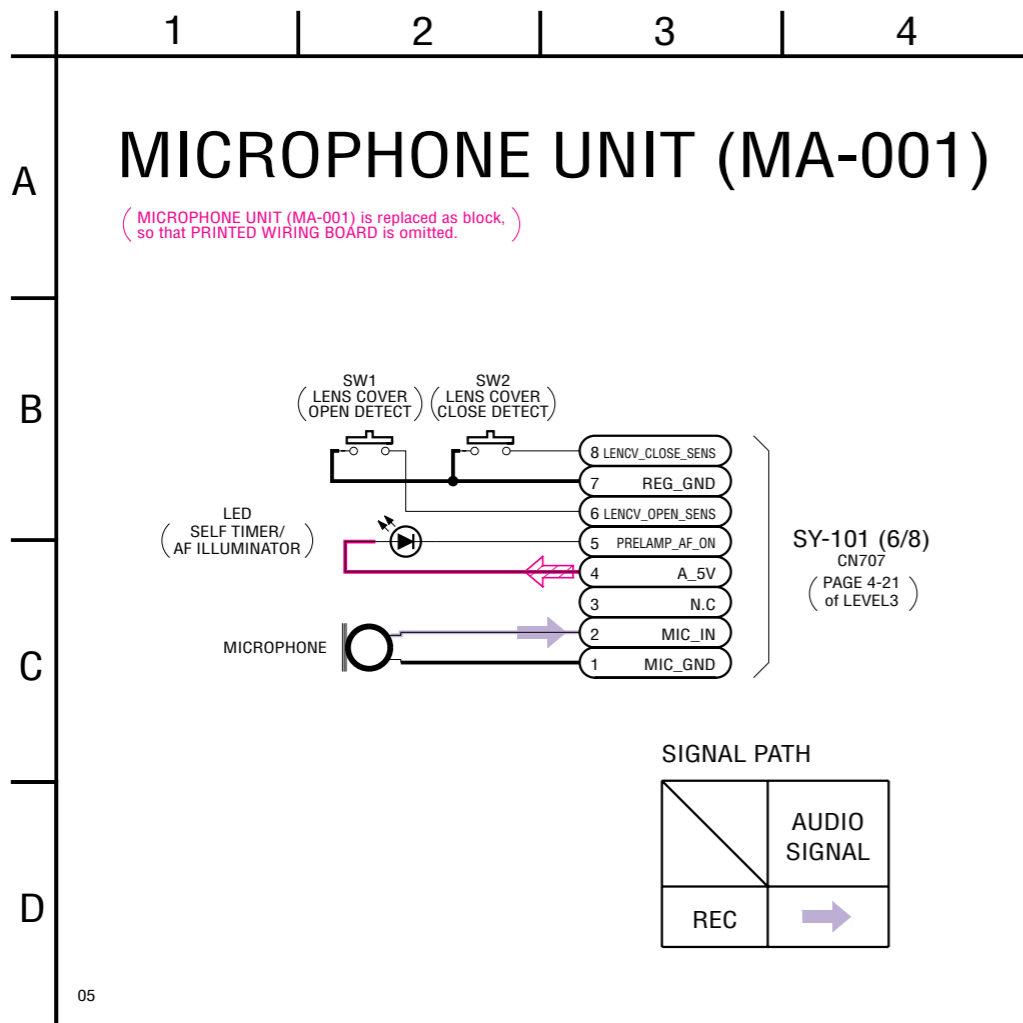

4-3. PRINTED WIRING BOARDS

Link

• CD-501 BOARD	• MS BOARD (FP-861 FLEXIBLE BOARD)
• SW-420 BOARD	• FP-860 FLEXIBLE BOARD
• ST-098 BOARD	







• COMMON NOTE FOR PRINTED WIRING BOARDS		
• MOUNTED PARTS LOCATION	• CIRCUIT BOARDS LOCATION	• FLEXIBLE BOARDS LOCATION

Board Name	Function
CD-501	CCD IMAGER
SW-420	CONTROL SWITCH, LCD DRIVE
ST-098	FLASH DRIVE
MS (FP-861)	MEMORY STICK CONNECTOR

4-3. PRINTED WIRING BOARDS

4-3. PRINTED WIRING BOARDS

THIS NOTE IS COMMON FOR PRINTED WIRING BOARDS

-  : Uses unleaded solder.
-  : Circuit board
-  : Flexible board
-  : Pattern from the side which enables seeing.
-  : pattern of the rear side
(The other layers' patterns are not indicated)
- Through hole is omitted.
- Circled numbers refer to waveforms.
- There are a few cases that the part printed on diagram isn't mounted in this model.
-  : panel designation

- Chip parts.
Transistor

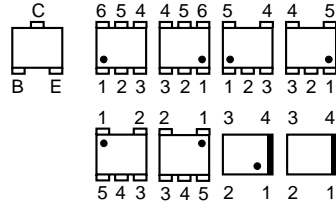

- Diode

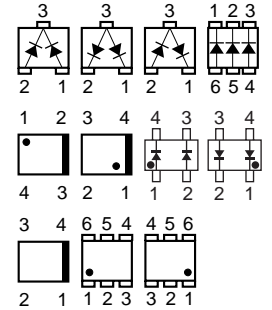

Board Name	Parts Location	Pattern	
		Total Number of Layers	Layers Not Indicated
CD-501	4-49	4 layers	2 and 3 layers
SW-420	4-52	4 layers	2 and 3 layers
ST-098	4-52	4 layers	2 and 3 layers
MS	-	1 layer	-

CD-501

Note for Printed Wiring Board (See page 4-35).

 : Uses unleaded solder.

CD-501 BOARD (SIDE A)

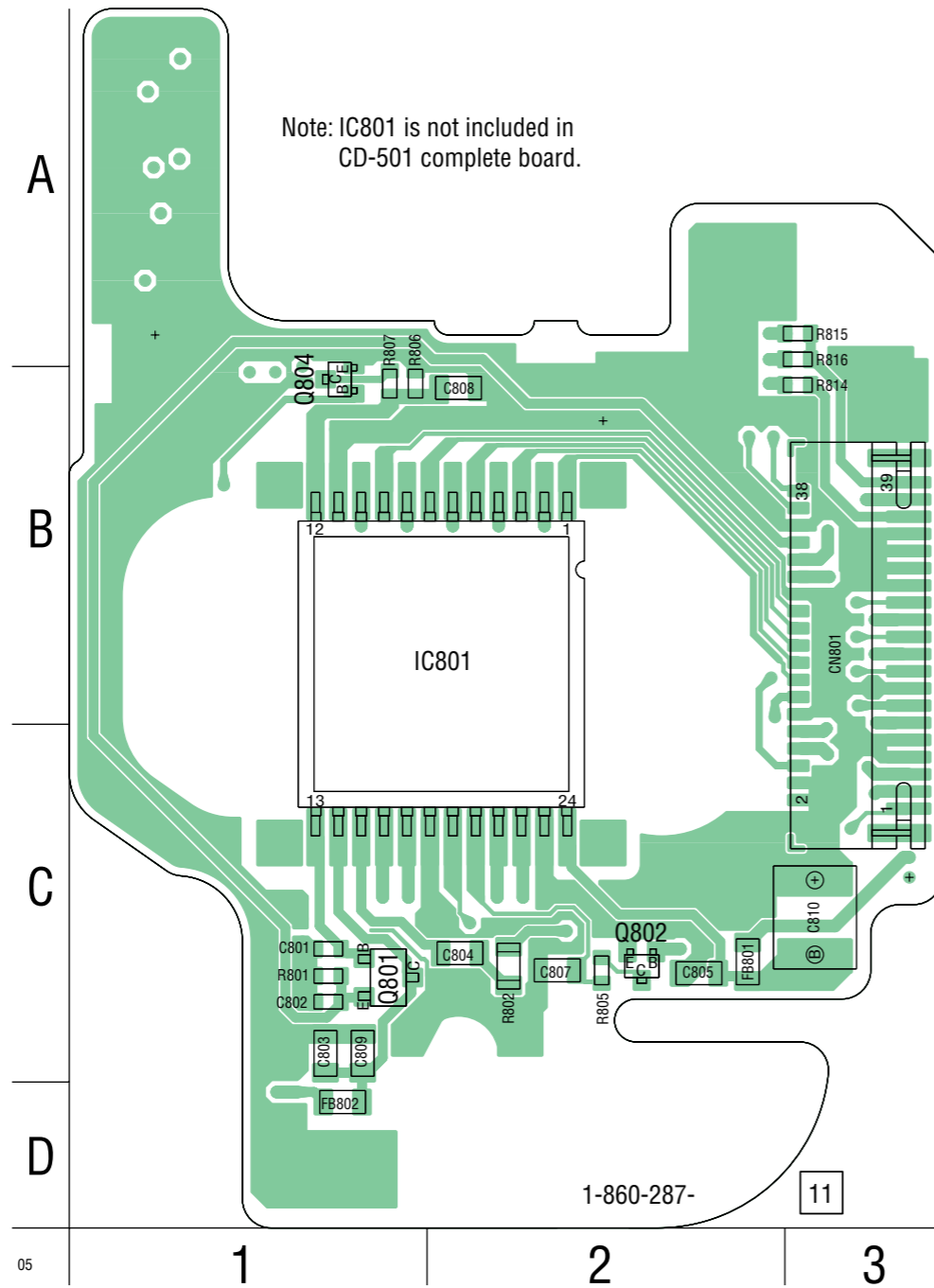

CD-501 BOARD (SIDE B)

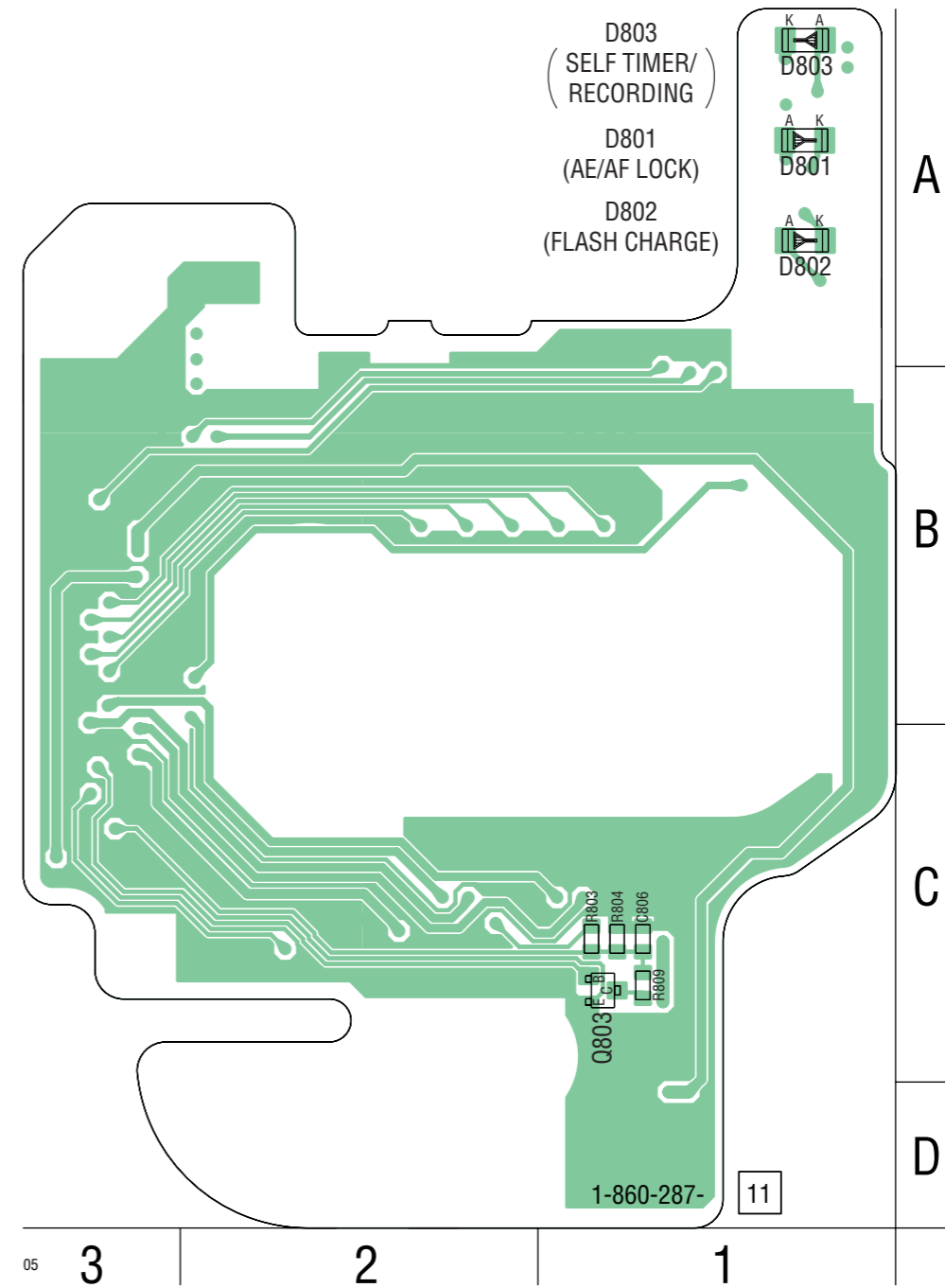

Printed wiring boards of the CH-146 and SY-101 boards are not shown.
Pages from 4-39 to 4-42 are not shown.

SW-420

Note for Printed Wiring Board (See page 4-35).

 : Uses unleaded solder.

SW-420 BOARD (SIDE A)

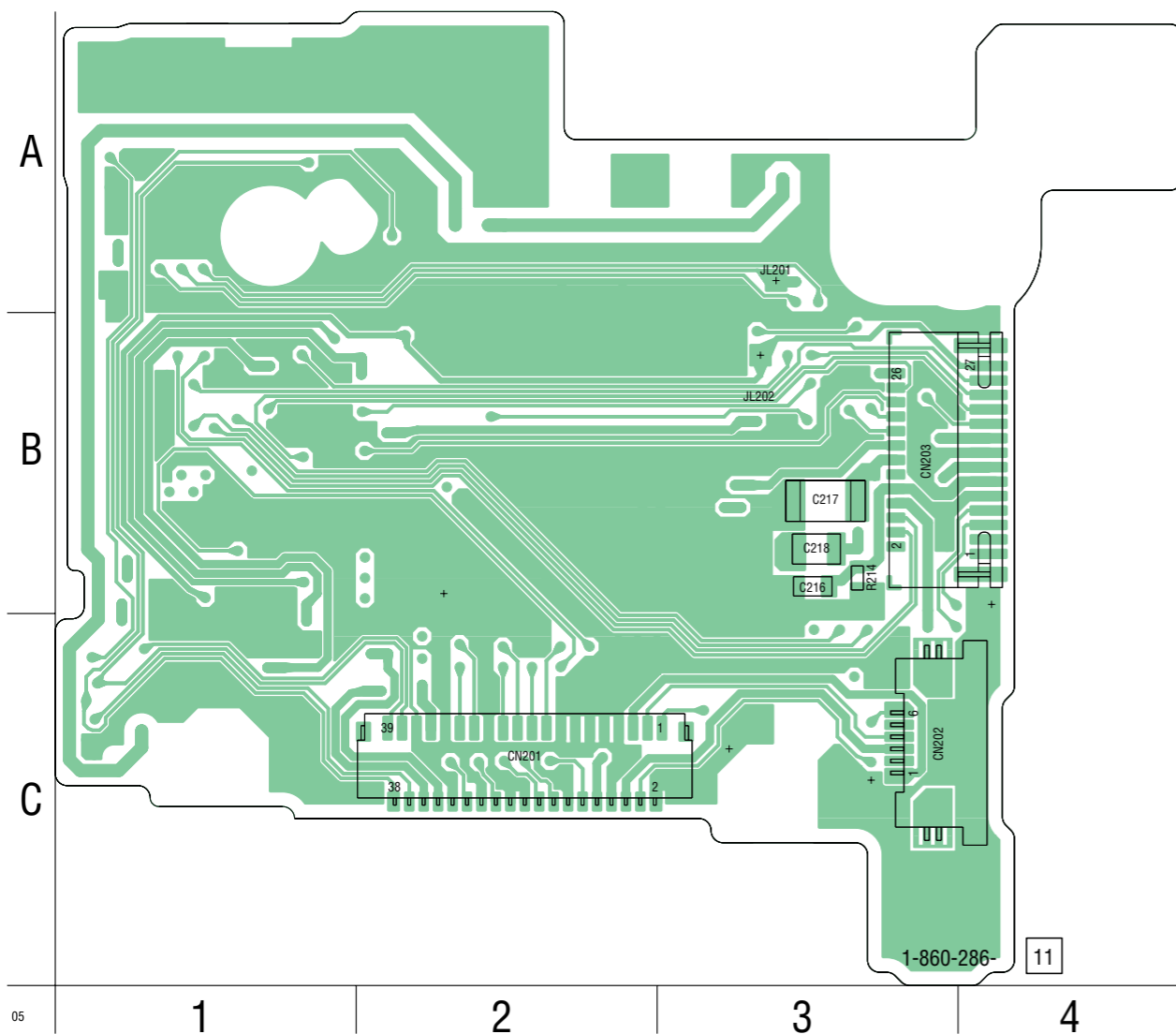

SW-420 BOARD (SIDE B)

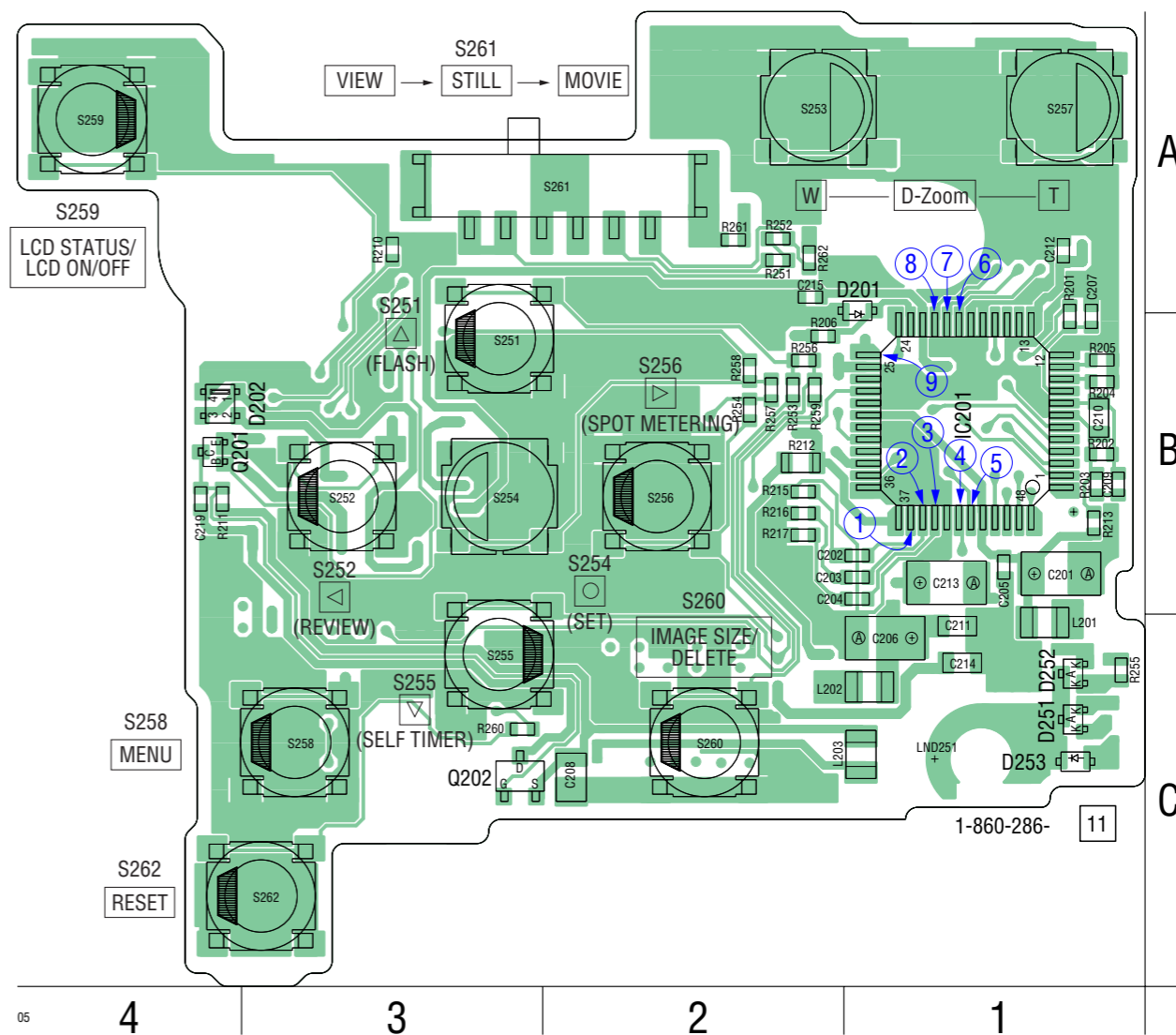

ST-098

Note for Printed Wiring Board (See page 4-35).

 : Uses unleaded solder.

ST-098 BOARD (SIDE A)

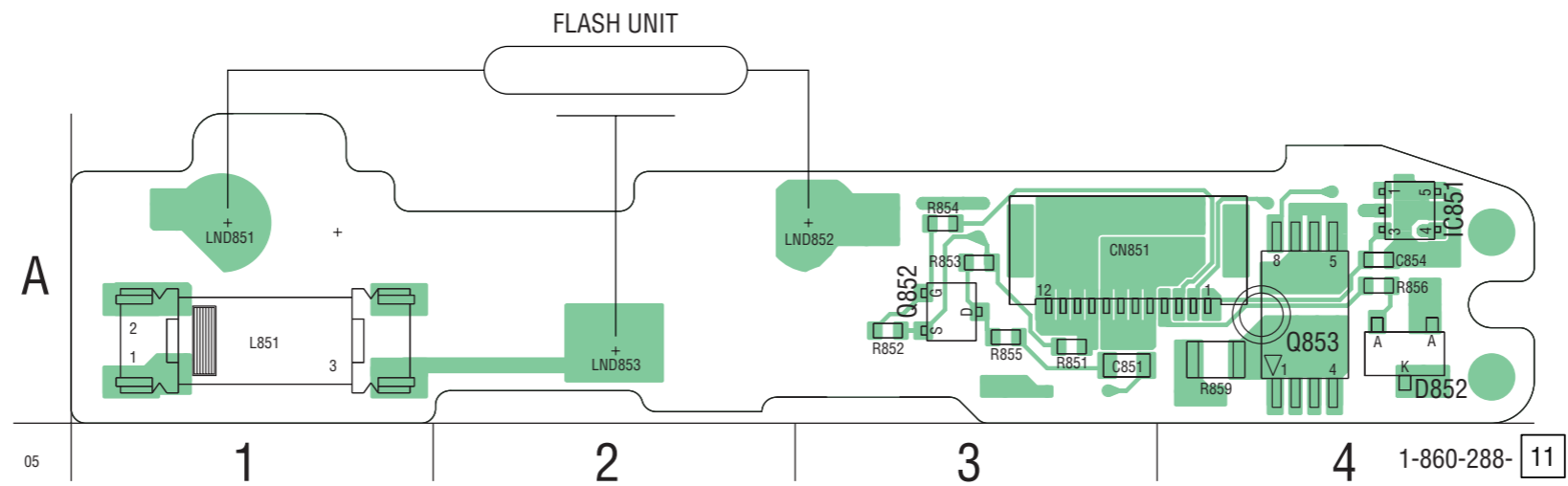

ST-098 BOARD (SIDE B)

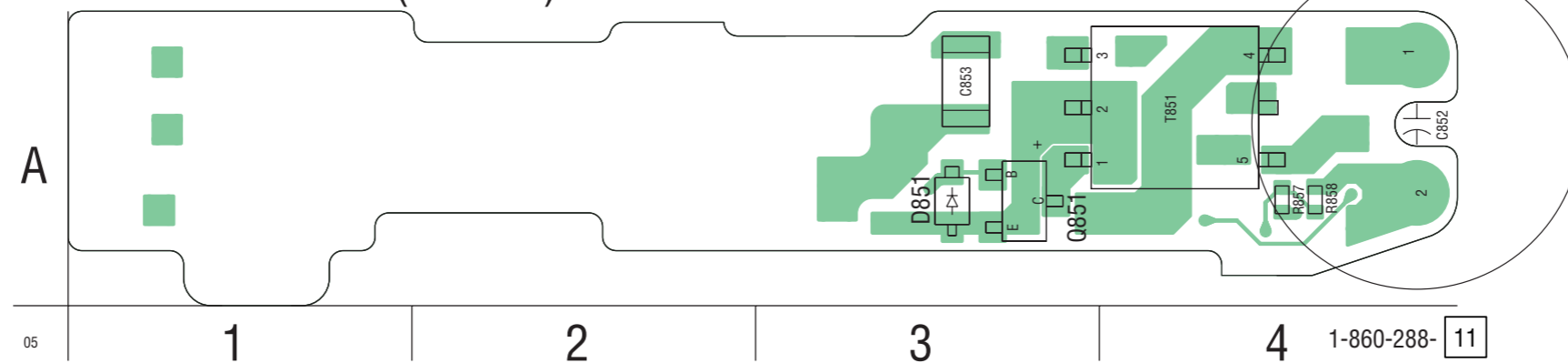

MS (FP-861 FLEXIBLE)

Note for Printed Wiring Board (See page 4-35).

 : Uses unleaded solder.

MS BOARD
(FP-861 FLEXIBLE BOARD)

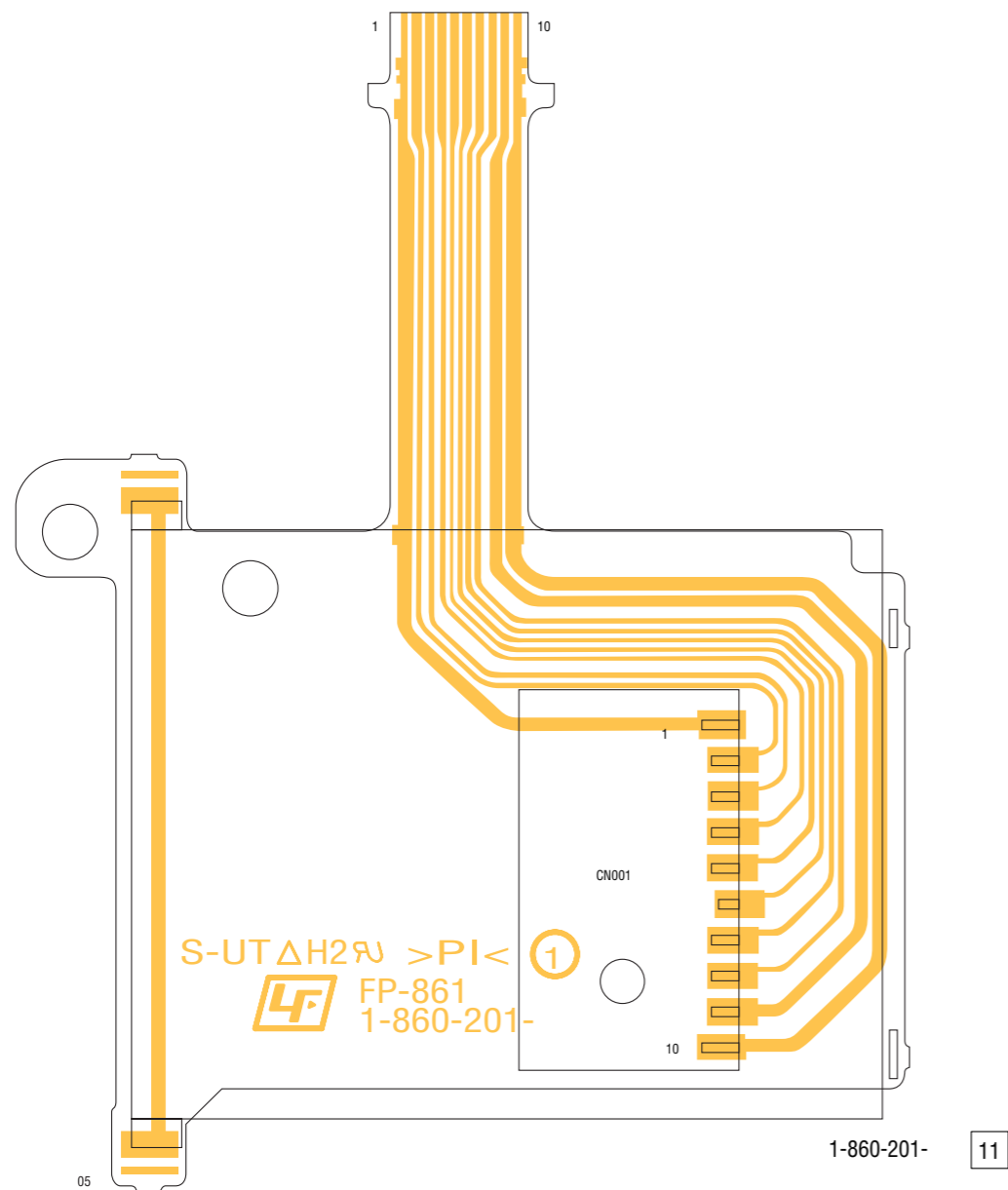

FP-860 FLEXIBLE

Note for Printed Wiring Board (See page 4-35).

 : Uses unleaded solder.

FP-860 FLEXIBLE BOARD

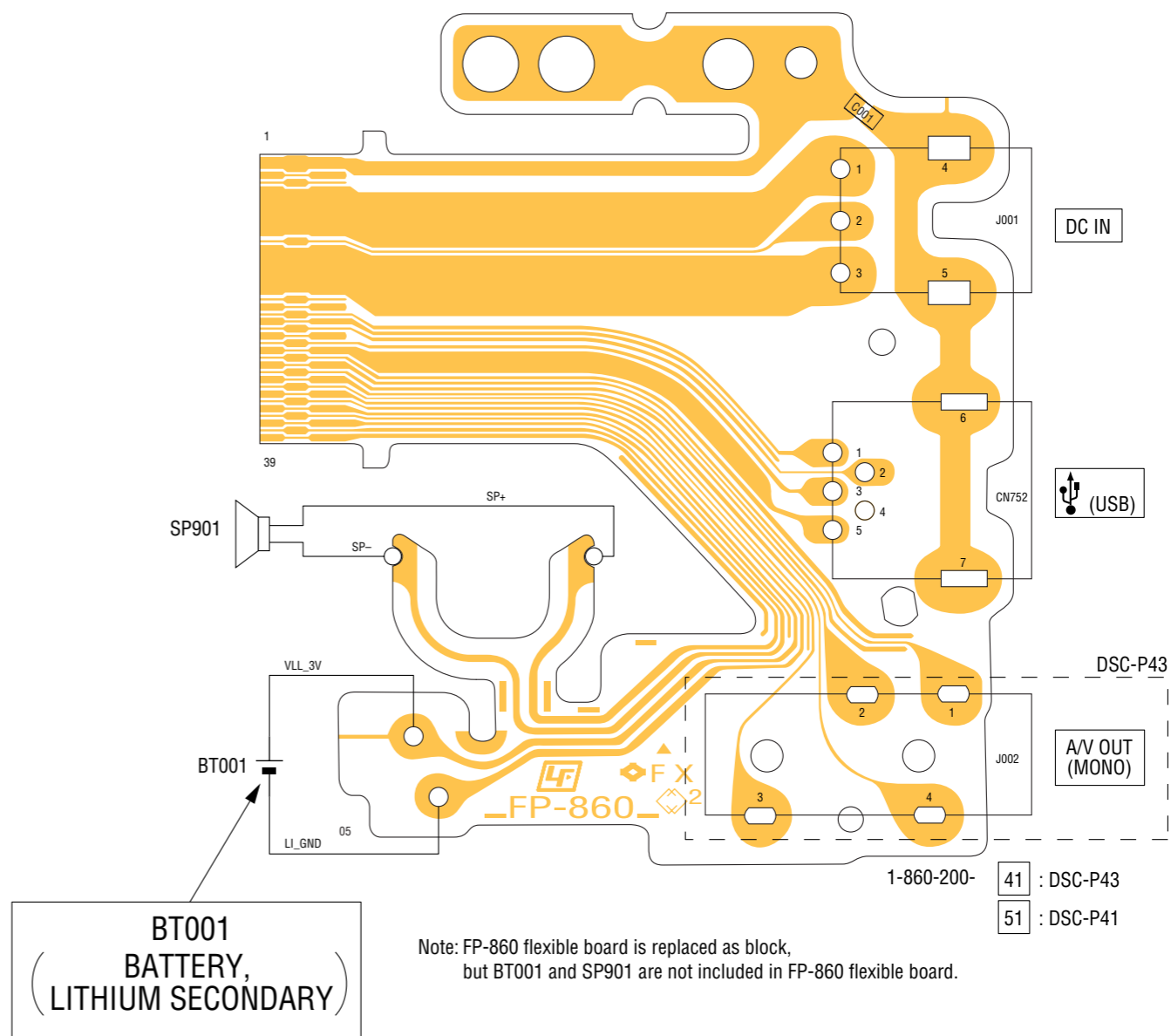

4-3. PRINTED WIRING BOARDS

4-4. MOUNTED PARTS LOCATION

no mark : side A

* mark : side B

CD-501 BOARD

C801 C-1
 C803 C-1
 C804 C-2
 C805 C-2
 C807 C-2
 C809 C-1
 C810 C-3

CN801 B-3

* D801 A-1
 * D802 A-1
 * D803 A-1

FB801 C-2
 FB802 D-1

IC801 B-2

Q801 C-1
 Q802 C-2
 * Q803 C-1
 Q804 B-1

R801 C-1
 R802 C-2
 * R803 C-1
 * R804 C-1
 R805 C-2
 R806 A-1
 R807 A-1
 * R809 C-1
 R814 B-3
 R815 A-3
 R816 A-3

Mounted parts location of the CH-146 and SY-101 boards are not shown.
Pages 4-50 and 4-51 are not shown.

4-3. PRINTED WIRING BOARDS

no mark : side A

* mark : side B

SW-420 BOARD

ST-098 BOARD





* C201	B-1	C851	A-3
* C202	B-2	* C853	A-3
* C203	B-2	C854	A-4
* C204	B-2		
* C205	B-1	CN851	A-3
* C206	C-1		
* C207	A-1	* D851	A-3
* C208	C-2	D852	A-4
* C209	B-1		
* C210	B-1	IC851	A-4
* C211	C-1		
* C212	A-1	L851	A-1
* C213	B-1		
* C214	C-1	* Q851	A-3
C216	B-3	Q852	A-3
C217	B-3	Q853	A-4
C218	B-3		
CN201	C-2	R851	A-3
CN202	C-3	R852	A-3
CN203	B-3	R853	A-3
		R854	A-3
		R855	A-3
* D202	B-3	R856	A-4
* D251	C-1	* R857	A-4
* D252	C-1	* R858	A-4
* D253	C-1	R859	A-4
* IC201	B-1	* T851	A-4
* L201	C-1		
* L202	C-2		
* L203	C-2		
* Q201	B-4		
* Q202	C-3		
* R201	A-1		
* R203	B-1		
* R204	B-1		
* R205	B-1		
* R206	B-2		
* R210	A-3		
* R211	B-4		
* R212	B-2		
R214	B-3		
* R215	B-2		
* R216	B-2		
* R217	B-2		
* R251	A-2		
* R252	A-2		
* R253	B-2		
* R254	B-2		
* R255	C-1		
* R256	B-2		
* R257	B-2		
* R258	B-2		
* R259	B-2		
* R260	C-3		
* R262	A-2		
* S251	B-3		
* S252	B-3		
* S253	A-2		
* S254	B-3		
* S255	C-3		
* S256	B-2		
* S257	A-1		
* S258	C-3		
* S259	A-4		
* S260	C-2		
* S261	A-2		
* S262	C-3		

NOTE

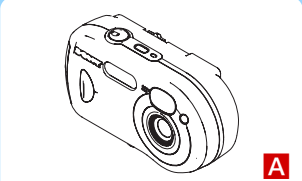
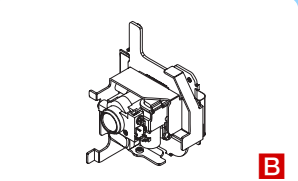
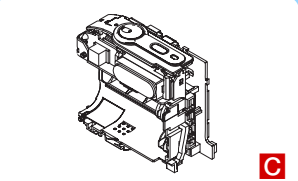
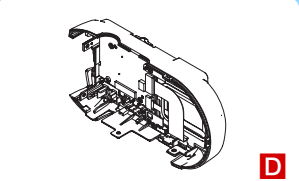
5. REPAIR PARTS LIST

NOTE: Characters **A** to **Z** of the electrical parts list indicate location of exploded views in which the desired part is shown.

Link	EXPLODED VIEWS			
				
FRONT CABINET BLOCK SECTION	LENS BLOCK SECTION	BT HOLDER BLOCK SECTION	REAR CABINET BLOCK SECTION	

Link	ELECTRICAL PARTS LIST				ACCESSORIES
 CD-501 BOARD	B	 ST-098 BOARD	C		
 MS BOARD	C	 SW-420 BOARD	D		

5. REPAIR PARTS LIST

SECTION 5 REPAIR PARTS LIST

NOTE:

- -XX, -X mean standardized parts, so they may have some differences from the original one.
- Items marked "*" are not stocked since they are seldom required for routine service. Some delay should be anticipated when ordering these items.
- The mechanical parts with no reference number in the exploded views are not supplied.
- Due to standardization, replacements in the parts list may be different from the parts specified in the diagrams or the components used on the set.
- CAPACITORS:
uF: μ F
- COILS
uH: μ H
- RESISTORS
All resistors are in ohms.
METAL: metal-film resistor
METAL OXIDE: Metal Oxide-film resistor
F: nonflammable
- SEMICONDUCTORS
In each case, u: μ , for example:
uA...: μ A... , uPA... , μ PA... ,
uPB... , μ PB... , μ PC... , μ PC... ,
uPD... , μ PD...
- Abbreviation
AR : Argentine model
AUS : Australian model
BR : Brazilian model
CH : Chinese model
CND : Canadian model
HK : Hong Kong model
J : Japanese model
JE : Tourist model
KR : Korean model

When indicating parts by reference number, please include the board name.

The components identified by mark \triangle or dotted line with mark \triangle are critical for safety. Replace only with part number specified.

Les composants identifiés par une marque \triangle sont critiques pour la sécurité. Ne les remplacer que par une pièce portant le numéro spécifié.

5. REPAIR PARTS LIST

5-1. EXPLODED VIEWS

5-1-1. FRONT CABINET BLOCK SECTION

ns: not supplied

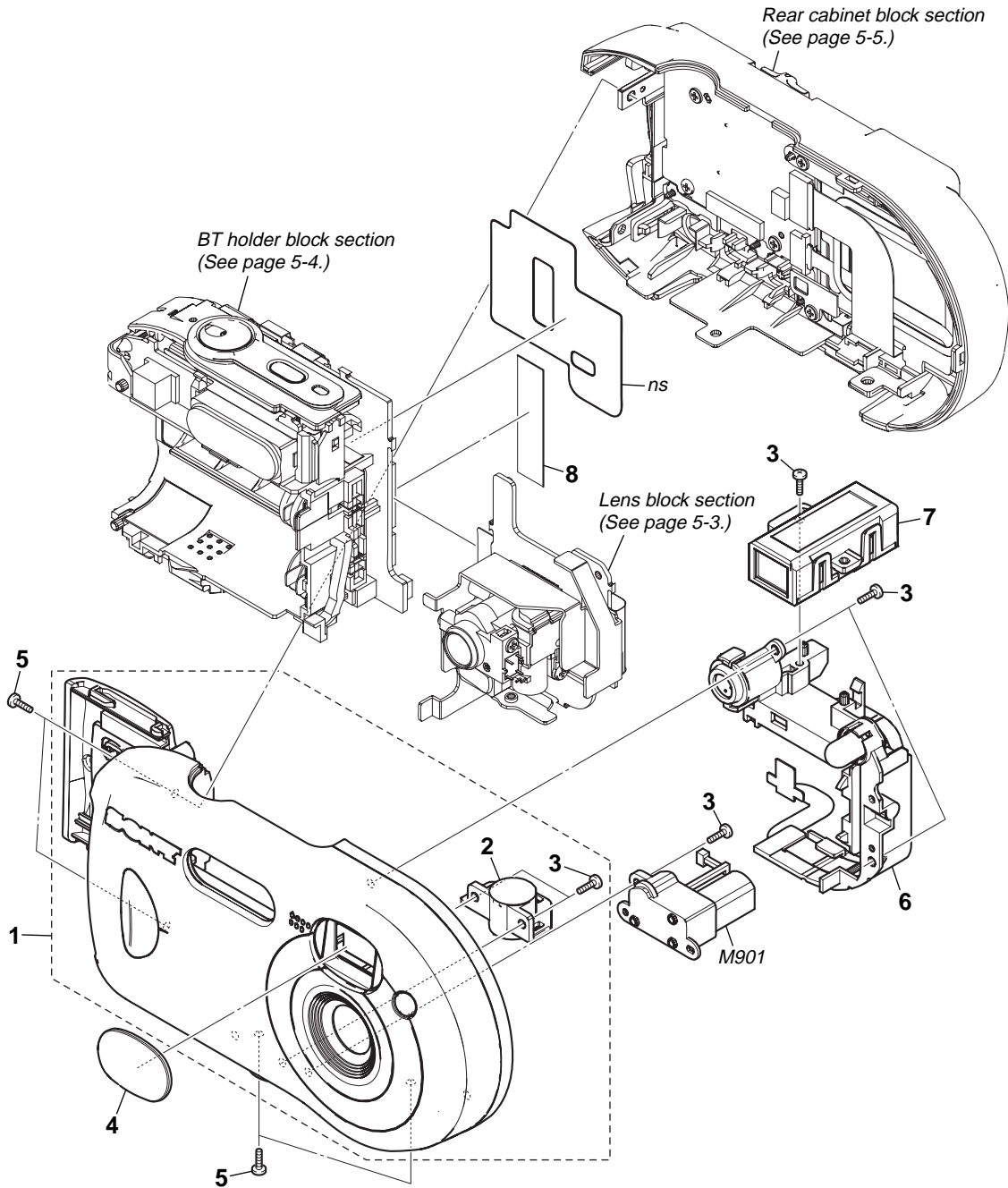

Ref. No.	Part No.	Description
1	X-2021-517-1	CABINET (FRONT) ASSY (450) (P41)
1	X-3954-373-1	CABINET (FRONT) ASSY (510) (P43)
2	3-080-977-01	TRIPOD
3	3-080-204-21	SCREW, TAPPING, P2
4	3-090-844-01	WINDOW (510), OVF

Ref. No.	Part No.	Description
5	2-025-236-31	SCREW (M1.7)
6	1-478-387-11	MICROPHONE UNIT (MA-001)
7	1-758-897-11	FINDER, OPTICAL (LSV-860A)
8	3-941-343-21	TAPE (A)
M901	1-763-818-21	MOTOR, DC 8C-027G

5. REPAIR PARTS LIST

5-1-2. LENS BLOCK SECTION

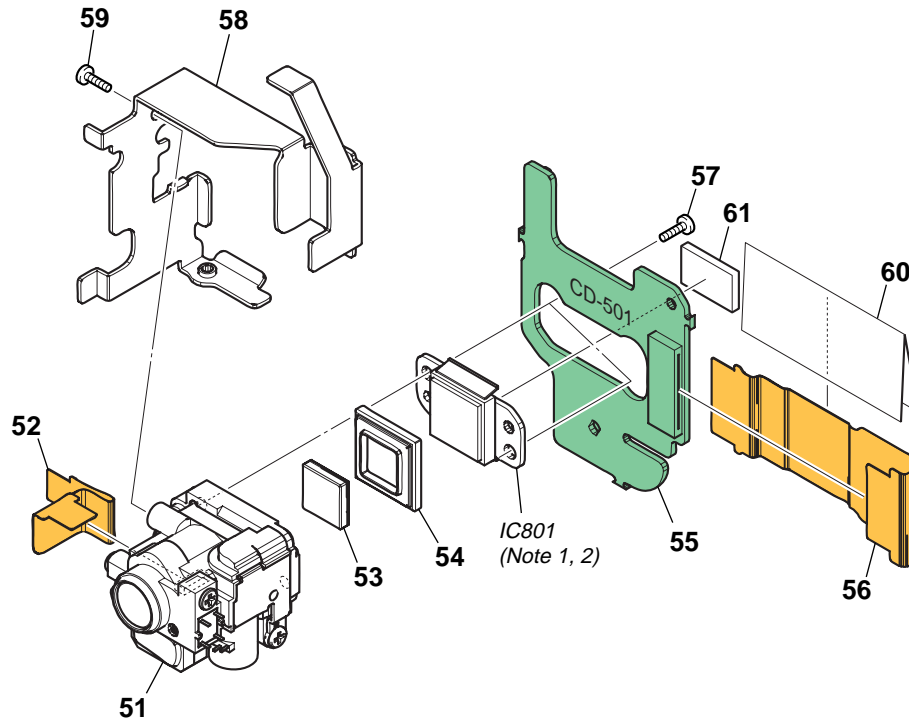

(Note 1) IC801 is not included in CD-501 complete board.

(Note 2) Be sure to read "Precautions for Replacement of CCD Imager" on page 4-8 when changing the CCD imager.

Ref. No.	Part No.	Description
51	8-848-757-01	LSV-780A
52	1-860-196-21	FP-856 FLEXIBLE BOARD
53	1-788-102-11	OPTICAL FILTER BLOCK
54	3-074-038-01	RUBBER (MM), CCD SEAL
55	A-7113-099-A	CD-501 BOARD, COMPLETE
56	1-860-193-21	FP-853 FLEXIBLE BOARD

Ref. No.	Part No.	Description
57	3-078-890-11	SCREW, TAPPING
58	3-090-843-01	FRAME (510), LENS
59	3-080-204-21	SCREW, TAPPING, P2
60	2-109-447-01	SHEET (510), CD
61	2-109-995-01	SHEET (510), LCD
IC801	A-7112-263-A	CCD BLOCK ASSY (CCD IMAGER) (Note 1, 2)

5. REPAIR PARTS LIST

5-1-3. BT HOLDER BLOCK SECTION

ns: not supplied

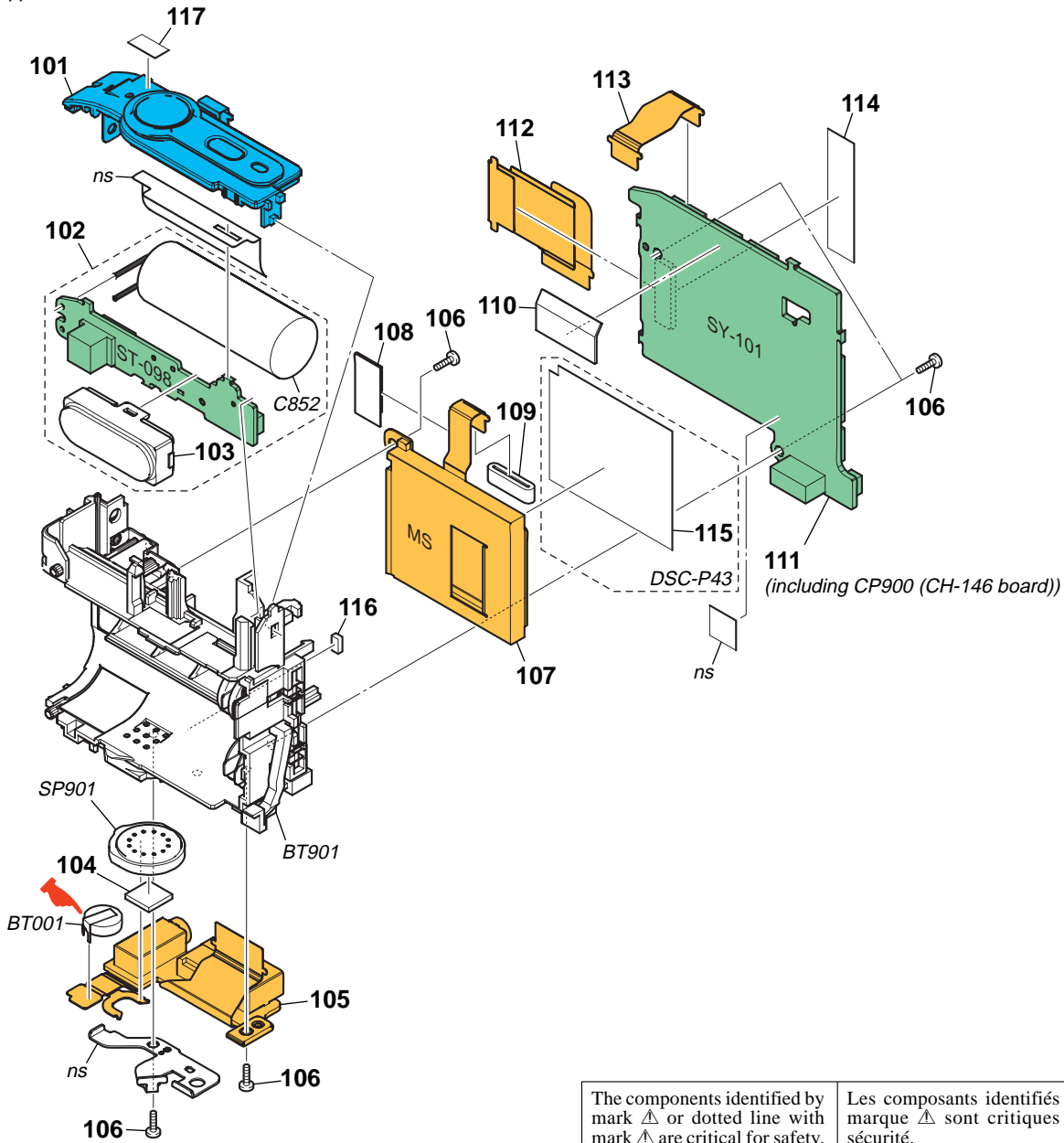

: BT001 (BATTERY, LITHIUM SECONDARY)
(Refer to page 4-48.)

The components identified by mark Δ or dotted line with mark Δ are critical for safety. Replace only with part number specified.	Les composants identifiés par une marque Δ sont critiques pour la sécurité. Ne les remplacer que par une pièce portant le numéro spécifié.
--	---

Ref. No.	Part No.	Description
101	1-478-302-11	SWITCH BLOCK, CONTROL
102	A-7113-098-A	ST-098 BOARD, COMPLETE
Δ 103	1-478-348-11	FLASH UNIT
104	3-090-797-01	CUSHION, SP
105	1-860-200-41	FP-860 FLEXIBLE BOARD (P43)
105	1-860-200-51	FP-860 FLEXIBLE BOARD (P41)
106	3-080-204-21	SCREW, TAPPING, P2
107	A-7113-208-A	MS BOARD, COMPLETE
108	2-050-538-01	SHEET, MS RADIATION
109	1-400-770-11	FERRITE CORE
110	2-050-462-01	SHEET (530), RL ELECTROSTATIC
111	A-1059-807-A	SY-101 BOARD, COMPLETE (SERVICE) (including CP900 (CH-146 board)) (P43)

Ref. No.	Part No.	Description
111	A-1059-808-A	SY-101 BOARD, COMPLETE (SERVICE) (including CP900 (CH-146 board)) (P41)
112	1-860-199-11	FP-859 FLEXIBLE BOARD
113	1-860-192-11	FP-852 FLEXIBLE BOARD
114	3-941-343-21	TAPE (A)
115	2-067-931-01	SHEET, MS SHEET METAL (P43)
116	2-067-932-01	CUSHION, MS CONDUCTIVE
117	2-109-666-01	SHEET (510), RL COPPER LEAF
Δ BT001	1-528-999-51	BATTERY, LITHIUM SECONDARY
BT901	1-756-421-11	BATTERY HOLDER (WITH TERMINAL)
Δ C852	1-100-737-11	CAP, ELECT 135uF 310V
SP901	1-825-665-11	SPEAKER (1.3CM)

5. REPAIR PARTS LIST

5-1-4. REAR CABINET BLOCK SECTION

ns: not supplied

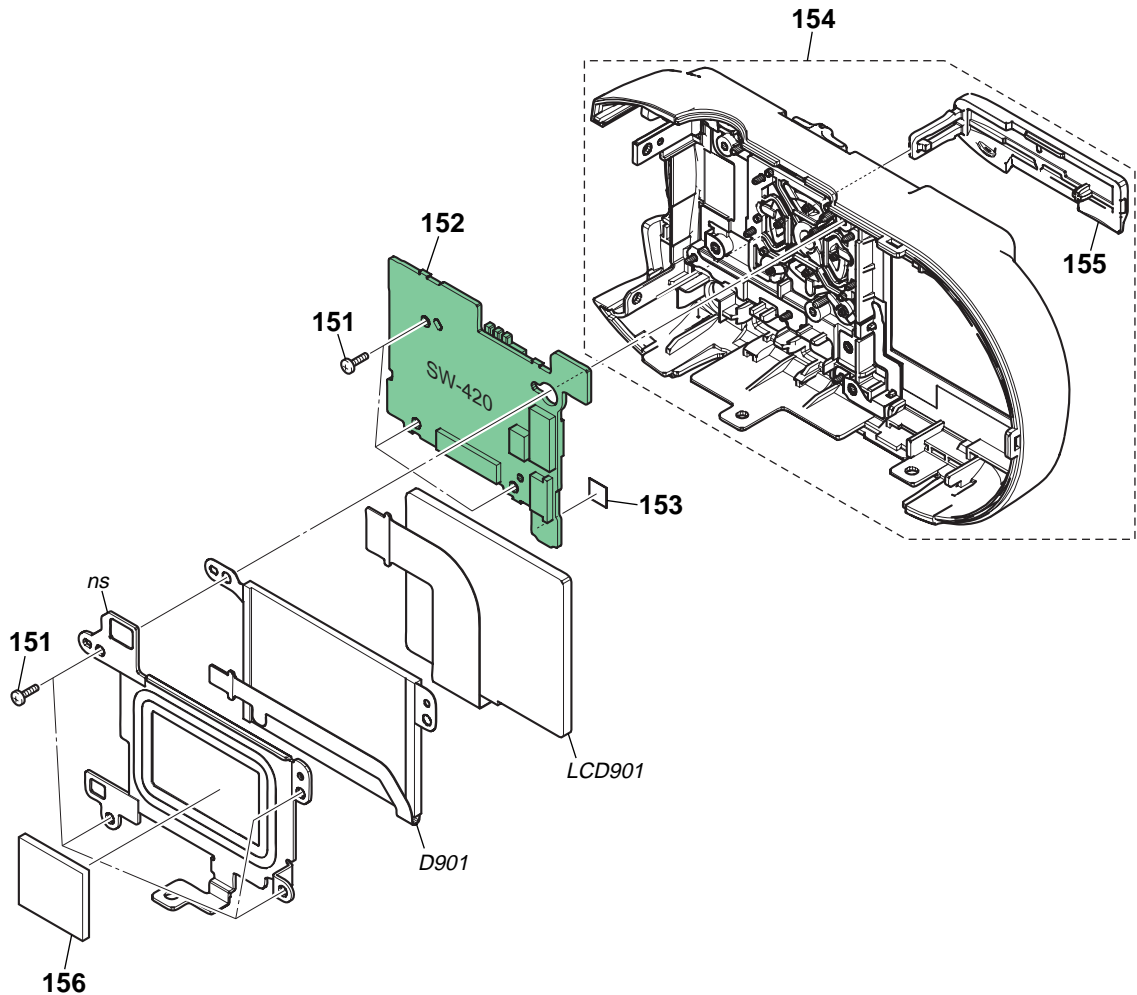

<p>The components identified by mark Δ or dotted line with mark Δ are critical for safety. Replace only with part number specified.</p>	<p>Les composants identifiés par une marque Δ sont critiques pour la sécurité. Ne les remplacer que par une pièce portant le numéro spécifié.</p>
---	---

Ref. No.	Part No.	Description
151	3-078-890-11	SCREW, TAPPING
152	A-7113-097-A	SW-420 BOARD, COMPLETE
153	3-090-794-01	SHEET, RESET
154	X-2021-518-1	CABINET (REAR) ASSY (450) (P41)
154	X-3954-374-1	CABINET (REAR) ASSY (510) (P43)
155	3-090-789-21	COVER, JK (P41)

Ref. No.	Part No.	Description
155	3-090-789-11	COVER, JK (P43)
156	2-022-234-01	SHEET (510), CCD RADIATION
Δ D901	1-478-465-21	BLOCK, LIGHT GUIDE PLATE (1.5) (P41)
Δ D901	1-478-465-11	BLOCK, LIGHT GUIDE PLATE (1.5) (P43)
LCD901	1-805-500-21	LCD MODULE (COD15T1506E)

CD-501

5-2. ELECTRICAL PARTS LIST

Ref. No.	Part No.	Description
	A-7113-099-A	CD-501 BOARD, COMPLETE ***** (IC801 is not included in this complete board.)
< CAPACITOR >		
C801	1-164-850-11	CERAMIC CHIP 10PF 0.5PF 50V
C803	1-107-826-11	CERAMIC CHIP 0.1uF 10% 16V
C804	1-107-826-11	CERAMIC CHIP 0.1uF 10% 16V
C805	1-107-826-11	CERAMIC CHIP 0.1uF 10% 16V
C807	1-107-826-11	CERAMIC CHIP 0.1uF 10% 16V
C809	1-107-826-11	CERAMIC CHIP 0.1uF 10% 16V
C810	1-135-957-91	TANTAL. CHIP 10uF 20% 16V
< CONNECTOR >		
CN801	1-816-057-11	CONNECTOR, FPC (ZIF) 39P
< DIODE >		
D801	8-719-075-29	DIODE SML-510MWT86S (AE/AF LOCK)
D802	8-719-077-34	DIODE SML-310YTT86 (FLASH CHARGE)
D803	8-719-064-07	DIODE SML-310LTT86 (SELF TIMER/RECORDING)
< FERRITE BEAD >		
FB801	1-414-228-11	INDUCTOR, FERRITE BEAD
FB802	1-414-228-11	INDUCTOR, FERRITE BEAD
< IC >		
IC801	A-7112-263-A	CCD BLOCK ASSY (CCD IMAGER) (Note)
< TRANSISTOR >		
Q801	6-550-885-01	TRANSISTOR 2SC39320S2S0
Q802	6-550-119-01	TRANSISTOR DTC144EMT2L
Q803	6-550-119-01	TRANSISTOR DTC144EMT2L
Q804	6-550-119-01	TRANSISTOR DTC144EMT2L
< RESISTOR >		
R801	1-218-959-11	RES-CHIP 3.3K 5% 1/16W
R802	1-216-864-11	SHORT CHIP 0
R803	1-218-990-11	SHORT CHIP 0
R804	1-218-989-11	RES-CHIP 1M 5% 1/16W
R805	1-220-184-11	RES-CHIP 1.3K 5% 1/16W
R806	1-218-957-11	RES-CHIP 2.2K 5% 1/16W
R807	1-218-953-11	RES-CHIP 1K 5% 1/16W
R809	1-218-980-11	RES-CHIP 180K 5% 1/16W
R814	1-218-940-11	RES-CHIP 82 5% 1/16W
R815	1-218-940-11	RES-CHIP 82 5% 1/16W
R816	1-218-952-11	RES-CHIP 820 5% 1/16W

Electrical parts list of the CH-146 board is not shown.
Pages 5-7 is not shown.

(Note) Be sure to read "Precautions for Replacement of CCD Imager" on page 4-8 when changing the CCD imager.

DSC-P41/P43

MS **ST-098** **SW-420**

Ref. No.	Part No.	Description
	A-7113-208-A	MS BOARD, COMPLETE *****
		< CONNECTOR >
CN001	1-815-572-61	CONNECTOR, MEMORY STICK
	A-7113-098-A	ST-098 BOARD, COMPLETE *****
△	1-478-348-11	FLASH UNIT < CAPACITOR >
C851	1-127-715-91	CERAMIC CHIP 0.22uF 10% 16V
△ C852	1-100-737-11	CAP, ELECT 135uF 310V
△ C853	1-100-758-11	CERAMIC CHIP 0.047uF 10% 250V
C854	1-125-777-11	CERAMIC CHIP 0.1uF 10% 10V
		< CONNECTOR >
CN851	1-816-644-31	FFC/FPC CONNECTOR (LIF) 12P < DIODE >
△ D851	8-719-073-01	DIODE MA111-(K8).SO
△ D852	6-500-962-01	DIODE HAU160C030STP < IC >
△ IC851	6-703-635-01	IC TND721MH5-S-TL-E < COIL >
△ L851	1-456-193-11	COIL, TRIGGER < TRANSISTOR >
△ Q851	6-550-759-01	TRANSISTOR CPH3235-S-TL-E
△ Q852	6-550-887-01	TRANSISTOR RTF025N03TL
△ Q853	6-550-656-01	TRANSISTOR CY25BAJ-8F-T23 < RESISTOR >
R851	1-218-957-11	RES-CHIP 2.2K 5% 1/16W
R852	1-218-977-11	RES-CHIP 100K 5% 1/16W
R853	1-218-956-11	RES-CHIP 1.8K 5% 1/16W
R854	1-218-965-11	RES-CHIP 10K 5% 1/16W
R855	1-218-943-11	RES-CHIP 150 5% 1/16W
R856	1-218-961-11	RES-CHIP 4.7K 5% 1/16W
R857	1-218-937-11	RES-CHIP 47 5% 1/16W
R858	1-218-989-11	RES-CHIP 1M 5% 1/16W
R859	1-216-121-11	RES-CHIP 1M 5% 1/10W < TRANSFORMER >
△ T851	1-437-737-11	TRANSFORMER, DC-DC CONVERTER
	A-7113-097-A	SW-420 BOARD, COMPLETE *****
		< CAPACITOR >
C201	1-100-539-91	TANTAL. CHIP 47uF 20% 6.3V
C202	1-164-943-11	CERAMIC CHIP 0.01uF 10% 16V
C203	1-164-943-11	CERAMIC CHIP 0.01uF 10% 16V

Ref. No.	Part No.	Description
C204	1-164-943-11	CERAMIC CHIP 0.01uF 10% 16V
C205	1-125-777-11	CERAMIC CHIP 0.1uF 10% 10V
C206	1-113-986-11	TANTAL. CHIP 2.2uF 20% 25V
C207	1-164-939-11	CERAMIC CHIP 0.0022uF 10% 50V
C208	1-100-670-11	CERAMIC CHIP 4.7uF 20% 16V
C209	1-125-777-11	CERAMIC CHIP 0.1uF 10% 10V
C210	1-164-739-11	CERAMIC CHIP 560PF 5% 50V
C211	1-107-826-11	CERAMIC CHIP 0.1uF 10% 16V
C212	1-125-777-11	CERAMIC CHIP 0.1uF 10% 10V
C213	1-113-994-11	TANTAL. CHIP 6.8uF 20% 16V
C214	1-165-908-11	CERAMIC CHIP 1uF 10% 10V
C216	1-107-826-11	CERAMIC CHIP 0.1uF 10% 16V
C217	1-127-861-11	CERAMIC CHIP 2.2uF 10% 16V
C218	1-127-573-11	CERAMIC CHIP 1uF 10% 16V
		< CONNECTOR >
CN201	1-817-942-11	CONNECTOR, FPC (ZIF) 39P
CN202	1-794-322-11	CONNECTOR, FFC/FPC (ZIF) 6P
CN203	1-794-410-11	CONNECTOR, FPC (ZIF) 27P < DIODE >
D202	6-500-054-01	DIODE RB481YT2R
D251	6-500-776-01	DIODE MAZW068H0LS0
D252	6-500-776-01	DIODE MAZW068H0LS0
D253	8-719-056-23	DIODE MA2S111-(K8).SO < IC >
IC201	6-705-547-01	IC CM7103L43-T4 < COIL >
L201	1-469-846-11	INDUCTOR 47uH
L202	1-400-588-11	INDUCTOR, LAMINATE CHIP 10uH
L203	1-400-588-11	INDUCTOR, LAMINATE CHIP 10uH < TRANSISTOR >
Q201	6-550-119-01	TRANSISTOR DTC144EMT2L
Q202	6-550-150-01	TRANSISTOR SSM3J09FU (TE85L) < RESISTOR >
R201	1-218-953-11	RES-CHIP 1K 5% 1/16W
R203	1-218-975-11	RES-CHIP 68K 5% 1/16W
R204	1-208-935-11	METAL CHIP 100K 0.5% 1/16W
R205	1-208-707-11	METAL CHIP 10K 0.5% 1/16W
R206	1-218-965-11	RES-CHIP 10K 5% 1/16W
R210	1-218-979-11	RES-CHIP 150K 5% 1/16W
R211	1-218-985-11	RES-CHIP 470K 5% 1/16W
R212	1-216-864-11	SHORT CHIP 0
R214	1-218-985-11	RES-CHIP 470K 5% 1/16W
R215	1-208-677-11	METAL CHIP 560 0.5% 1/16W
R216	1-208-677-11	METAL CHIP 560 0.5% 1/16W
R217	1-208-677-11	METAL CHIP 560 0.5% 1/16W
R251	1-218-959-11	RES-CHIP 3.3K 5% 1/16W
R252	1-218-955-11	RES-CHIP 1.5K 5% 1/16W
R253	1-218-954-11	RES-CHIP 1.2K 5% 1/16W
R254	1-218-954-11	RES-CHIP 1.2K 5% 1/16W
R255	1-218-954-11	RES-CHIP 1.2K 5% 1/16W
R256	1-218-955-11	RES-CHIP 1.5K 5% 1/16W

The components identified by mark △ or dotted line with mark △ are critical for safety. Replace only with part number specified.	Les composants identifiés par une marque △ sont critiques pour la sécurité. Ne les remplacer que par une pièce portant le numéro spécifié.
--	--

Ref. No.	Part No.	Description			
R257	1-218-955-11	RES-CHIP	1.5K	5%	1/16W
R258	1-218-959-11	RES-CHIP	3.3K	5%	1/16W
R259	1-218-959-11	RES-CHIP	3.3K	5%	1/16W
R260	1-218-953-11	RES-CHIP	1K	5%	1/16W
R262	1-218-954-11	RES-CHIP	1.2K	5%	1/16W

< SWITCH >

S251	1-771-138-82	SWITCH, KEY BOARD (▲ (FLASH))
S252	1-771-138-82	SWITCH, KEY BOARD (◀ (REVIEW))
S253	1-786-157-31	TACTILE SWITCH (D-Zoom (W))
S254	1-786-157-31	TACTILE SWITCH (● (SET))
S255	1-771-138-82	SWITCH, KEY BOARD (▼ (SELF TIMER))
S256	1-771-138-82	SWITCH, KEY BOARD (▶ (SPOT METERING))
S257	1-786-157-31	TACTILE SWITCH (D-Zoom (T))
S258	1-771-138-82	SWITCH, KEY BOARD (MENU)
S259	1-771-138-82	SWITCH, KEY BOARD (LCD STATUS / LCD ON/OFF)
S260	1-771-138-82	SWITCH, KEY BOARD (IMAGE SIZE/DELETE)
S261	1-771-487-21	SWITCH, SLIDE (VIEW/STILL/MOVIE (MODE SWITCH))
S262	1-771-138-82	SWITCH, KEY BOARD (RESET)

Electrical parts list of the SY-101 board is not shown.
Pages 5-10 to 5-14 are not shown.

Checking supplied accessories.

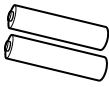

R6 (size AA) alkaline batteries (2)
(P41 only)
HR6 (size AA) Ni-MH batteries (2)
(P43 only)
(not supplied)

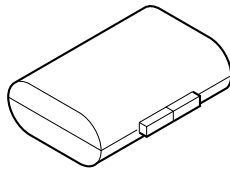

Battery case (1)
3-074-757-01

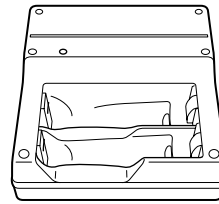

Battery charger (BC-CS2) (1)
(P43 only)
△ 1-477-814-11 (CND, JE, J)
△ 1-477-814-21
(AEP, UK, E, HK, AR, AUS)
△ 1-477-814-31 (CH, KR)

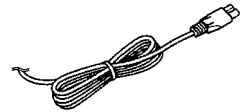

Power cord (1)
(P43 only)
△ 1-769-608-11 (AEP, E)
△ 1-776-985-11 (KR)
△ 1-782-476-13 (CH)
△ 1-783-374-11 (UK, HK)
△ 1-783-952-21 (AR)
△ 1-790-107-22 (CND)
△ 1-790-732-12 (JE, J)
△ 1-827-945-11 (AUS)

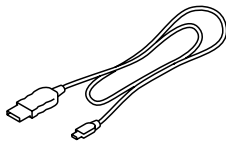

USB cable (1)
1-827-038-11

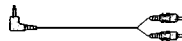

A/V connecting cable (1)
(P43 only)
1-824-111-11

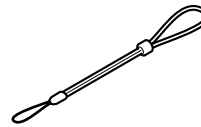

Wrist strap (1)
3-089-555-01

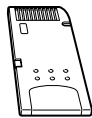

"Memory Stick" (16MB) (1)
(not supplied)

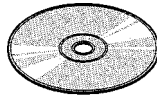

CD-ROM
(SPVD-012 USB driver) (1)
3-091-338-01 (US, J)
3-091-339-01
(EXCEPT US, J)

Other accessories

- 3-091-349-01 MANUAL, INSTRUCTION (for BASIC) (JAPANESE) (J)
- 3-091-349-11 MANUAL, INSTRUCTION (ENGLISH)
(US, CND, AEP, UK, E, HK, AUS, CH, JE)
- 3-091-349-21 MANUAL, INSTRUCTION (FRENCH, ITALIAN) (CND, AEP)
- 3-091-349-31 MANUAL, INSTRUCTION (SPANISH, PORTUGUESE)
(AEP, E, AR, JE)
- 3-091-349-41 MANUAL, INSTRUCTION (GERMAN, DUTCH) (AEP)
- 3-091-349-51 MANUAL, INSTRUCTION (TRADITIONAL CHINESE,
SIMPLIFIED CHINESE) (E, HK, CH, JE)
- 3-091-349-61 MANUAL, INSTRUCTION (RUSSIAN, SWEDISH) (AEP)
- 3-091-349-71 MANUAL, INSTRUCTION (ARABIC, PERSIAN) (E)
- 3-091-349-81 MANUAL, INSTRUCTION (KOREAN) (KR, JE)
- 3-091-349-91 MANUAL, INSTRUCTION (POLISH, CZECH) (AEP)
- 3-091-350-11 MANUAL, INSTRUCTION (HUNGARIAN, SLOVAK) (AEP)
- 3-091-351-01 MANUAL, INSTRUCTION (for APPLICATION) (J)



Conversion Adaptor (1)
(P43 only)
△ 1-569-007-11 (E)
△ 1-573-856-12 (JE)

The components identified by mark △ or dotted line with mark △ are critical for safety. Replace only with part number specified.

Les composants identifiés par une marque △ sont critiques pour la sécurité. Ne les remplacer que par une pièce portant le numéro spécifié.

[Description of main button functions on toolbar of the Adobe Acrobat Reader Ver5.0 (for Windows)]

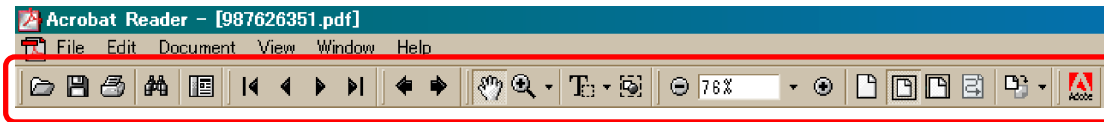

Toolbar



Printing a text

1. Click the Print button .
2. Specify a printer, print range, number of copies, and other options, and then click [OK].

Application of printing:

To set a range to be printed within a page, select the graphic selection tool  and drag on the page to enclose a range to be printed, and then click the Print button.

Reversing the screens displayed once

- To reverse the previous screens (operation) one by one, click the .
- To advance the reversed screens (operation) one by one, click the .

Application to the Service Manual:

This function allows you to go and back between circuit diagram and printed circuit board diagram, and accordingly it will be convenient for the voltage check.

Finding a text

1. Click the Find button .
2. Enter a character string to be found into a text box, and click the [Find]. (Specify the find options as necessary)

Application to the Service Manual:

To execute "find" from current page toward the previous pages, select the check box "Find Backwards" and then click the "Find".

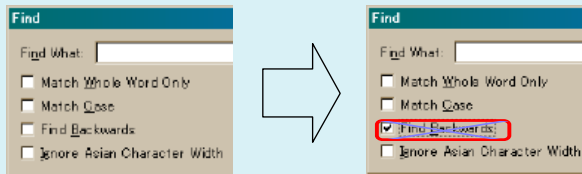





3. Open the find dialog box again, and click the [Find Again] and you can find the matched character strings displayed next. (Character strings entered previously are displayed as they are in the text box.)

Application to the Service Manual:

The parts on the drawing pages (block diagrams, circuit diagrams, printed circuit boards) and parts list pages in a text can be found using this find function. For example, find a Ref. No. of IC on the block diagram, and click the [Find Again] continuously, so that you can move to the Ref. No. of IC on the circuit diagram or printed circuit board diagram successively.

Note: The find function may not be applied to the Service Manual depending on the date of issue.

Moving with link

1. Select either palm tool , zoom tool , text selection tool , or graphic selection tool .
2. Place the pointer in the position in a text where the link exists (such as a button on cover and the table of contents page, or blue characters on the removal flowchart page or drawing page), and the pointer will change to the forefinger form .
3. Then, click the link. (You will go to the link destination.)

Moving with bookmark:

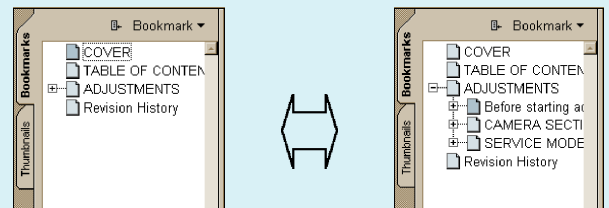

Click an item (text) on the bookmark pallet, and you can move to the link destination. Also, clicking  can display the hidden items.

(To go back to original state, click )



Zooming or rotating the screen display

"Zoom in/out"

- Click the triangle button in the zoom control box to select the display magnification. Or, you may click  or  for zooming in or out.

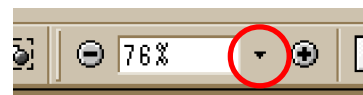





"Rotate"

- Click rotate tool , and the page then rotates 90 degrees each.

Application to the Service Manual:

The printed circuit board diagram you see now can be changed to the same direction as the set.

Switching a page

- To move to the first page, click the .
- To move to the last page, click the .
- To move to the previous page, click the .
- To move to the next page, click the .

Revision History

Ver.	Date	History	Contents	S.M. Rev. issued
1.0	2004.04	Official Release	—	—