

DSC-P200

SERVICE MANUAL

LEVEL 2

Ver 1.0 2005.01

Revision History

How to use
Acrobat Reader



Photo: Silver

US Model
Canadian Model
AEP Model
UK Model
E Model
Hong Kong Model
Australian Model
Chinese Model
Korea Model
Tourist Model

Link

SPECIFICATIONS	BLOCK DIAGRAMS	PRINTED WIRING BOARDS
SERVICE NOTE	FRAME SCHEMATIC DIAGRAM	REPAIR PARTS LIST
DISASSEMBLY	SCHEMATIC DIAGRAMS	

- For ADJUSTMENTS (SECTION 6), refer to SERVICE MANUAL, ADJ (9-876-854-51).
- For INSTRUCTION MANUAL, refer to SERVICE MANUAL, LEVEL 1 (9-876-854-41).
- **Reference No. search on printed wiring boards is available.**
- [Note in Lens Frame Installation](#)
- [Exchange Method of Barrier Assy](#)

On the CH-146, SY-123 boards

This service manual provides the information that is premised the circuit board replacement service and not intended repair inside the CH-146, SY-123 boards.

Therefore, schematic diagram, printed wiring board and electrical parts list of the CH-146, SY-123 boards are not shown.

The following pages are not shown.

Schematic diagrams	Pages 4-9 to 4-28
Printed wiring boards	Pages 4-39 to 4-42
Waveforms	Pages 4-45 and 4-46
Mounted parts location	Page 4-48 and 49
Electrical parts list	Pages 5-7 to 5-11

The above-described information is shown in service manual Level 3.

DIGITAL STILL CAMERA

SONY®



Cyber-shot



SPECIFICATIONS

Camera

[System]

Image device	9.11 mm (1/1.8 type) color CCD, Primary color filter
Total pixel number of camera	Approx. 7 410 000 pixels
Effective pixel number of camera	Approx. 7 201 000 pixels
Lens	Carl Zeiss Vario-Tessar 3× zoom lens f = 7.9 - 23.7 mm (38 - 114 mm when converted to a 35 mm still camera) F2.8 - 5.2
Exposure control	Automatic exposure, Manual exposure, Scene Selection (9 modes)
White balance	Automatic, Daylight, Cloudy, Fluorescent, Incandescent, Flash, One push
File format (DCF compliant)	Still images: Exif Ver. 2.2 JPEG compliant, DPOF compatible Movies: MPEG1 compliant (Monaural)
Recording media	"Memory Stick"
Flash	Recommended distance (ISO set to Auto): 0.2 m to 3.5 m (7 7/8 inches to 11 feet 5 3/4 inches) (W)/0.3 m to 2.5 m (11 7/8 inches to 8 feet 2 3/8 inches) (T)

[Input and Output connectors]

Multi connector	
USB communication	Hi-Speed USB (USB 2.0 compliant)

[LCD screen]

LCD panel	5.1 cm (2.0 type) TFT drive
Total number of dots	134 000 (560×240) dots

[Power, general]

Battery pack used	NP-FR1
Power requirements	3.6 V
Power consumption (during shooting with the LCD screen on)	1.2 W
Operating temperature	0°C to +40°C (+32°F to +104°F)
Storage temperature	-20°C to +60°C (-4°F to +140°F)
Dimensions	104.5×51.5×27.9 mm (4 1/8×2 1/8×1 1/8 inches) (W/H/D, excluding maximum protrusions)
Mass	Approx. 180 g (6.3 oz) (including NP-FR1 battery pack, "Memory Stick", and wrist strap)
Microphone	Electret condenser microphone
Speaker	Dynamic speaker
Exif Print	Compatible
PRINT Image Matching II	Compatible
PictBridge	Compatible

AC-LS5/LS5B AC Adaptor

Input rating	100 V to 240 V AC, 50/60 Hz, 11 W
Output rating	4.2 V DC* * See the label on the AC Adaptor for other specifications.
Operating temperature	0°C to +40°C (+32°F to +104°F)
Storage temperature	-20°C to +60°C (-4°F to +140°F)
Dimensions	Approx. 48×29×81 mm (1 15/16×1 3/16×3 1/4 inches) (W/H/D, excluding projecting parts)
Mass	Approx. 130 g (5 oz) excluding power cord (mains lead)

NP-FR1 battery pack

Battery used	Lithium-ion battery
Maximum voltage	DC 4.2 V
Nominal voltage	DC 3.6 V
Capacity	4.4 Wh (1 220 mAh)

Design and specifications are subject to change without notice.

CAUTION

Danger of explosion if battery is incorrectly replaced.
Replace only with the same or equivalent type.

SAFETY-RELATED COMPONENT WARNING!!

COMPONENTS IDENTIFIED BY MARK \triangle OR DOTTED LINE WITH MARK \triangle ON THE SCHEMATIC DIAGRAMS AND IN THE PARTS LIST ARE CRITICAL TO SAFE OPERATION. REPLACE THESE COMPONENTS WITH SONY PARTS WHOSE PART NUMBERS APPEAR AS SHOWN IN THIS MANUAL OR IN SUPPLEMENTS PUBLISHED BY SONY.

ATTENTION AU COMPOSANT AYANT RAPPORT À LA SÉCURITÉ!

LES COMPOSANTS IDENTIFÉS PAR UNE MARQUE \triangle SUR LES DIAGRAMMES SCHÉMATIQUES ET LA LISTE DES PIÈCES SONT CRITIQUES POUR LA SÉCURITÉ DE FONCTIONNEMENT. NE REMPLACER CES COMPOSANTS QUE PAR DES PIÈSES SONY DONT LES NUMÉROS SONT DONNÉS DANS CE MANUEL OU DANS LES SUPPLÉMENTS PUBLIÉS PAR SONY.

SAFETY CHECK-OUT

After correcting the original service problem, perform the following safety checks before releasing the set to the customer.

1. Check the area of your repair for unsoldered or poorly-soldered connections. Check the entire board surface for solder splashes and bridges.
2. Check the interboard wiring to ensure that no wires are "pinched" or contact high-wattage resistors.
3. Look for unauthorized replacement parts, particularly transistors, that were installed during a previous repair. Point them out to the customer and recommend their replacement.
4. Look for parts which, through functioning, show obvious signs of deterioration. Point them out to the customer and recommend their replacement.
5. Check the B+ voltage to see it is at the values specified.
6. Flexible Circuit Board Repairing
 - Keep the temperature of the soldering iron around 270°C during repairing.
 - Do not touch the soldering iron on the same conductor of the circuit board (within 3 times).
 - Be careful not to apply force on the conductor when soldering or unsoldering.

Unleaded solder

Boards requiring use of unleaded solder are printed with the lead-free mark (LF) indicating the solder contains no lead. (Caution: Some printed circuit boards may not come printed with the lead free mark due to their particular size.)



: LEAD FREE MARK

Unleaded solder has the following characteristics.

- Unleaded solder melts at a temperature about 40°C higher than ordinary solder.
Ordinary soldering irons can be used but the iron tip has to be applied to the solder joint for a slightly longer time.
Soldering irons using a temperature regulator should be set to about 350°C.
Caution: The printed pattern (copper foil) may peel away if the heated tip is applied for too long, so be careful!
- Strong viscosity
Unleaded solder is more viscous (sticky, less prone to flow) than ordinary solder so use caution not to let solder bridges occur such as on IC pins, etc.
- Usable with ordinary solder
It is best to use only unleaded solder but unleaded solder may also be added to ordinary solder.

TABLE OF CONTENTS

<u>Section</u>	<u>Title</u>	<u>Page</u>
1. SERVICE NOTE		
1-1.	Note for Repair	1-1
1-2.	Discharging of the FP-163 Flexible Board's Charging Capacitor (C601)	1-1
1-3.	Note in Lens Frame Installation	1-2
1-4.	Description on Self-diagnosis Display	1-2
2. DISASSEMBLY		
2-1.	Disassembly	2-1
2-2.	SY-123 Board Service Position	2-5
2-3.	Exchange Method of Barrier Assy	2-7
2-3-1.	Peel Off Old Ornamental Ring A	2-7
2-3-2.	Remove Old Barrier Assy	2-8
2-3-3.	Install New Barrier Assy	2-8
2-3-4.	Adhere the Ornamental Ring A	2-9
2-4.	Circuit Boards Location	2-10
3. BLOCK DIAGRAMS		
3-1.	Overall Block Diagram (1/2)	3-1
3-2.	Overall Block Diagram (2/2)	3-3
3-3.	Power Block Diagram (1/2)	3-5
3-4.	Power Block Diagram (2/2)	3-7
4. PRINTED WIRING BOARDS AND SCHEMATIC DIAGRAMS		
4-1.	Frame Schematic Diagram	4-1
4-2.	Schematic Diagrams	4-5
	CD-517 FLEXIBLE (CCD IMAGER)	4-7
	FP-162 FLEXIBLE (DC IN, MULTI CONNECTOR)	4-29
	FP-163 FLEXIBLE (FLASH)	4-30
	MEMORY STICK CONNECTOR (FP-161 FLEXIBLE)	4-30
	CONTROL SWITCH BLOCK (SW51740), (RL)	4-31
4-3.	Printed Wiring Boards	4-35
	CD-517 FLEXIBLE	4-37
	FP-162 FLEXIBLE	4-43
	FP-163 FLEXIBLE	4-44
4-5.	Mounted Parts Location	4-47
5. REPAIR PARTS LIST		
5-1.	Exploded Views	5-2
5-1-1.	Overall Assembly	5-2
5-1-2.	Lens Block Assembly	5-3
5-1-3.	Main Block Assembly	5-4
5-1-4.	BT Block Assembly	5-5
5-2.	Electrical Parts List	5-6

1. SERVICE NOTE

1-1. NOTE FOR REPAIR

Make sure that the flat cable and flexible board are not cracked or bent at the terminal.
Do not insert the cable insufficiently nor crookedly.

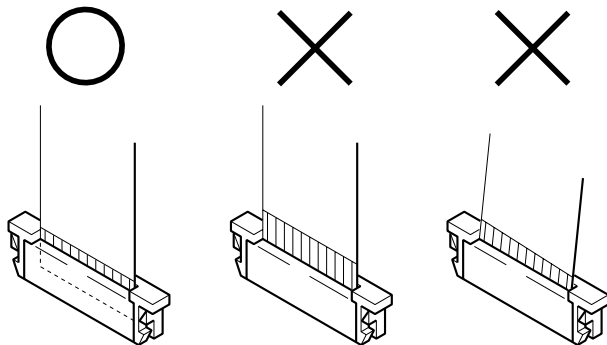

When remove a connector, don't pull at wire of connector.
It is possible that a wire is snapped.

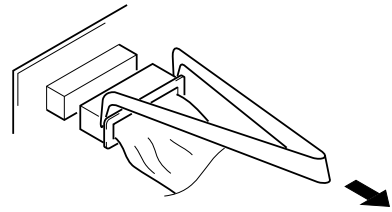

When installing a connector, don't press down at wire of connector.
It is possible that a wire is snapped.

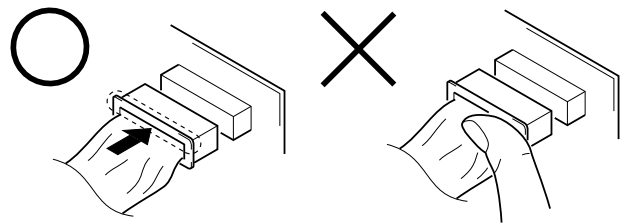

Cut and remove the part of gilt which comes off at the point.
(Be careful or some pieces of gilt may be left inside)

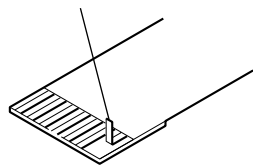

1-2. DISCHARGING OF THE FP-163 FLEXIBLE BOARD'S CHARGING CAPACITOR (C601)

The charging capacitor (C601) of the FP-163 flexible board is charged up to the maximum 300 V potential.
There is a danger of electric shock by this high voltage when the capacitor is handled by hand. The electric shock is caused by the charged voltage which is kept without discharging when the main power of the unit is simply turned off. Therefore, the remaining voltage must be discharged as described below.

Preparing the Short Jig

To preparing the short jig, a small clip is attached to each end of a resistor of 1 k Ω / 1 W (1-215-869-11).
Wrap insulating tape fully around the leads of the resistor to prevent electrical shock.

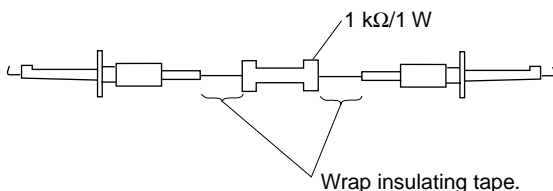

Discharging the Capacitor

Short-circuit between the positive and the negative terminals of charged capacitor with the short jig about 10 seconds.

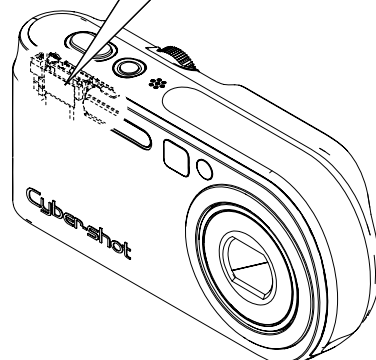
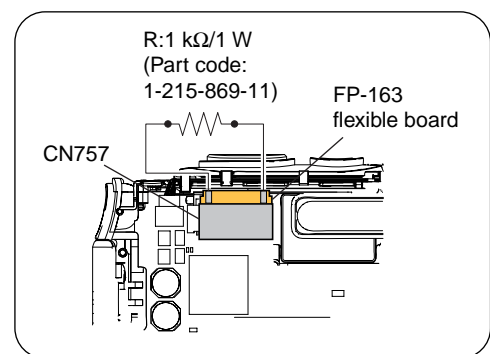

1-3. NOTE IN LENS FRAME INSTALLATION

When tightening a screw, have both sides of the lens block assembly so as not for the load to depend.

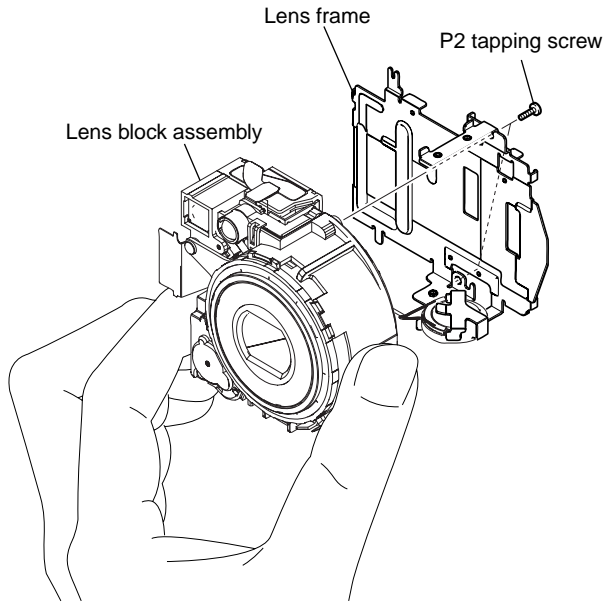

1-4. DESCRIPTION ON SELF-DIAGNOSIS DISPLAY

Self-diagnosis display

The camera has a self-diagnosis display. This function displays the camera condition with five-digits (a combination of a letter and figures) on the LCD screen. If this occurs check the following code chart. The five-digits display informs you of the camera's current condition. The last two digits (indicated by □□) will differ depending on the state of the camera.

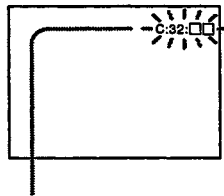

Self-diagnosis display

- C: □□: □□
You can reverse the camera malfunction yourself. (However, contact your Sony dealer or local authorized Sony service facility when you cannot recover from the camera malfunction.)
- E: □□: □□
Contact your Sony dealer or local authorized Sony service facility.

Display Code	Countermeasure	Cause	Caution Display During Error
C:32:□□	Turn the power off and on again.	Trouble with hardware.	SYSTEM ERROR
C:13:□□	Format the "Memory stick".	Unformatted memory stick is inserted.	FORMAT ERROR
	Insert a new "Memory Stick".	Memory stick is broken.	MEMORY STICK ERROR
E:61:□□	Checking of lens drive circuit.	When failed in the focus and zoom initialization.	—
E:91:□□	Checking of flash unit or replacement of flash unit.	Abnormality when flash is being charged.	

2. DISASSEMBLY

The following flow chart shows the disassembly procedure.

2-1. DISASSEMBLY

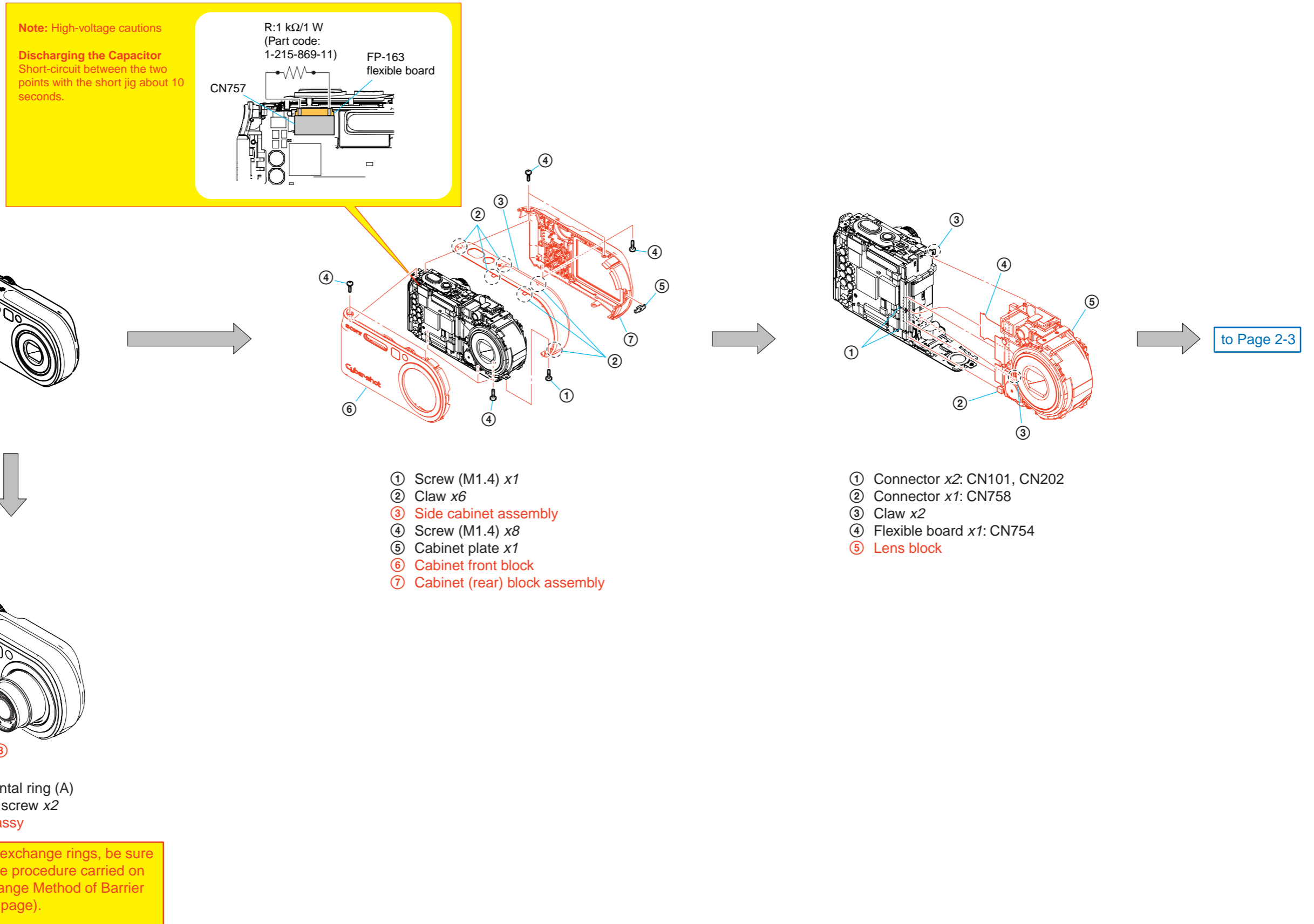

from Page 2-2

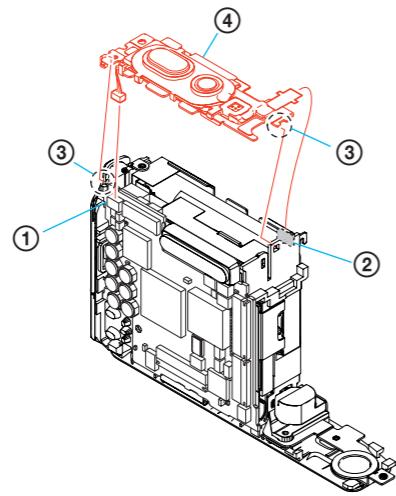
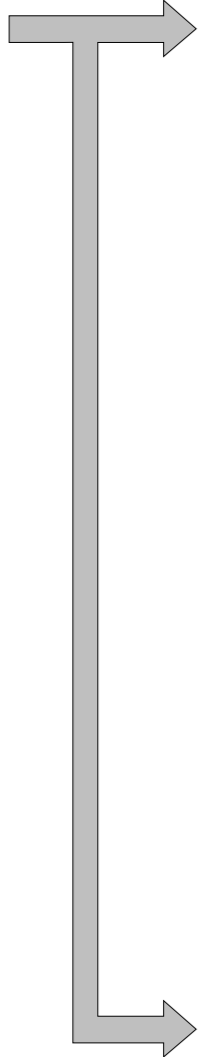

- ① Connector x1: CN707
- ② Connector x1: CN003
- ③ Claw x2
- ④ Control switch block

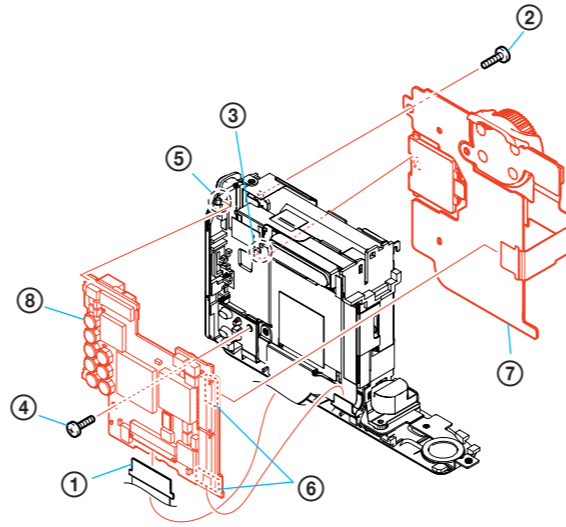

- ① Flexible board x1: CN704
- ② P2 tapping screw x1
- ③ Claw x1
- ④ P2 tapping screw (M1.7) x1
- ⑤ Claw x1
- ⑥ Connector x2: CN751, 756
- ⑦ Control SW block (SW51740)
- ⑧ SY-123 board

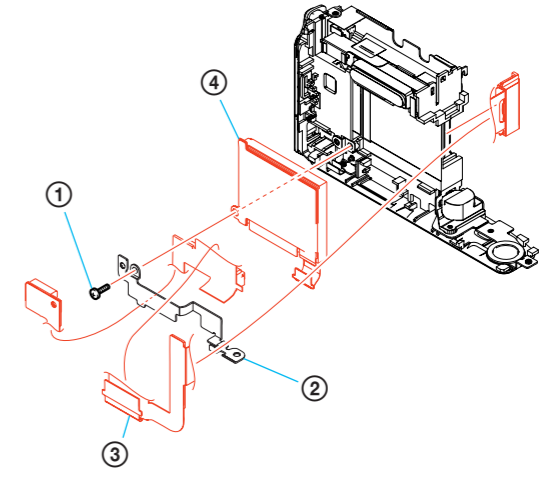

- ① P2 tapping screw x1
- ② Multi fixed plate x1
- ③ FP-162 flexible board
- ④ Memory stick connector

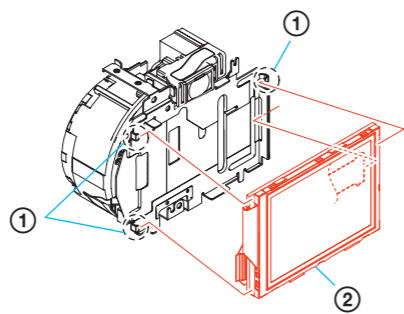

- ① Claw x3
- ② D901, LCD901

2-2. SY-123 BOARD SERVICE POSITION

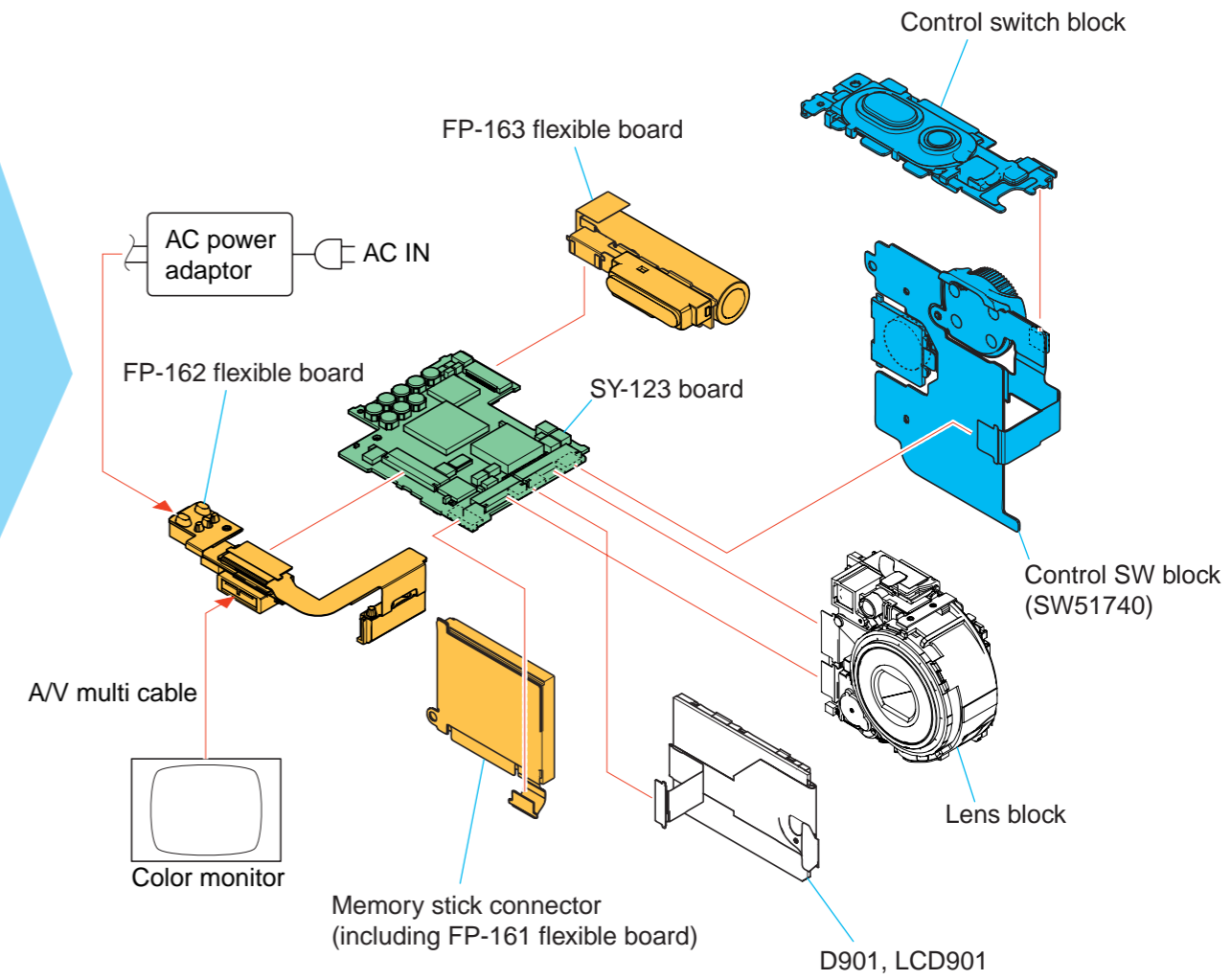
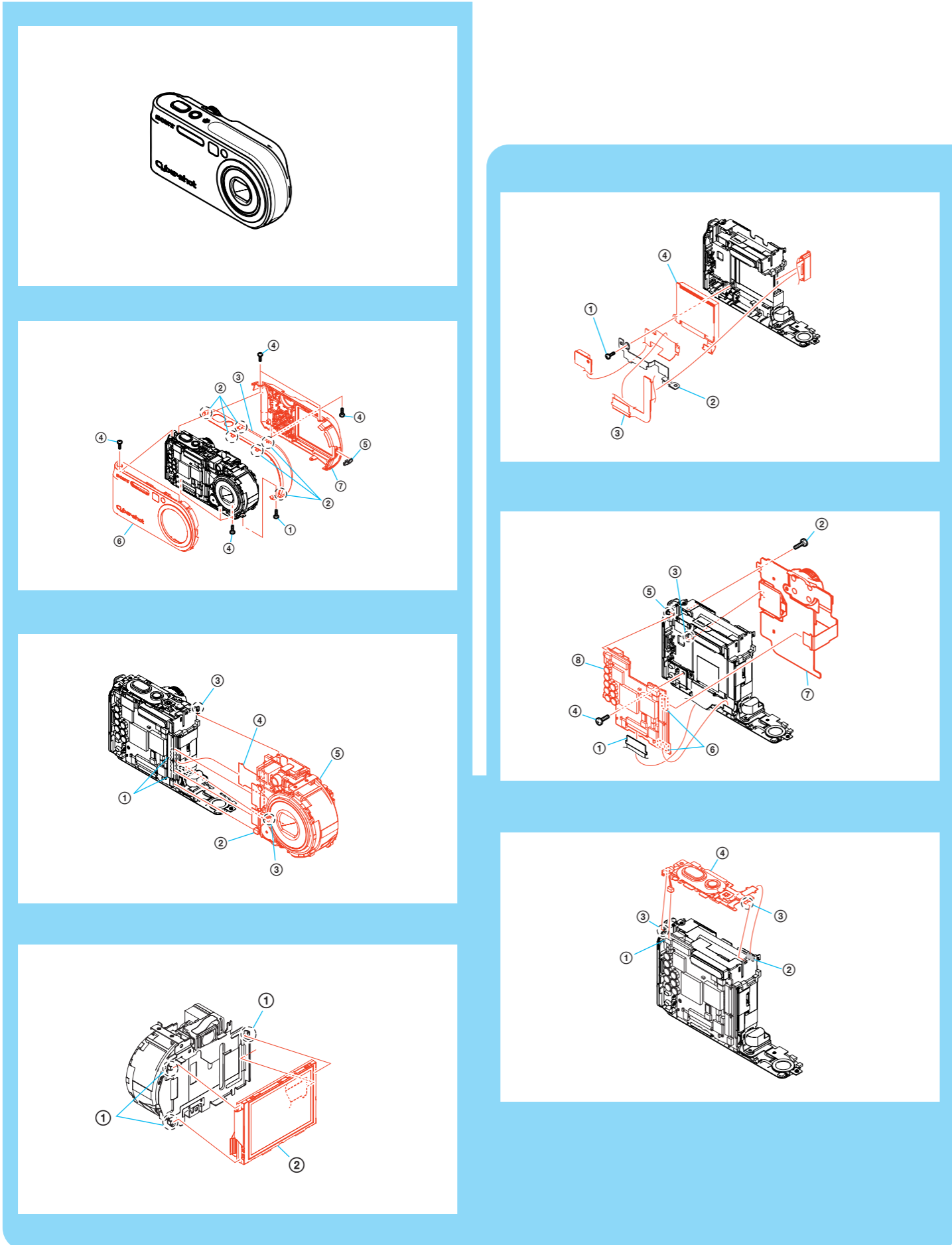

2-3. EXCHANGE METHOD OF BARRIER ASSY

Service parts

	Part Number	Part Name	Quantity
1	3-091-427-01	Ring (A), Ornamental	1
2	X-3954-476-1	Barrier Assy	1
3	3-086-156-31	Tapping screw (P2)	2

Tools used

Torque driver

Soldering iron

Weight about 60g

Adhesive (Super X) (Note)

Note: Use adhesive (Super X) or an equivalent article.

Don't use what becomes white after drying like a quick-drying glue.

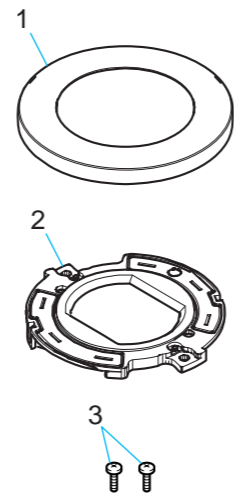

2-3-1. PEEL OFF OLD ORNAMENTAL RING A

The Ornamental Ring A has adhered to the Barrier Assy strongly and accordingly, use a soldering iron to weaken the adhesive force.

Heat four circled portions with the soldering iron.

Heating temperature is about 300°C.

Beware of a burn since the entire Ornamental Ring becomes hot.

* As the adhesive force of Ornamental Ring A is considerably large, the forced peeling will damage the group-1 frame.

Insert the tip of tweezers, etc. into a notch of the group-1 frame and prize the ring.

* Take extreme care so as not to damage the coated surface of the group-1 frame.

In case of difficult peeling, heat the ring again with the soldering iron.

If this re-heating failed, it may be advisable that the ring be peeled while heating the portions ① → ② → ③ → ④ in the under figure one by one sequentially.

* Discard the removed Ornamental Ring A.

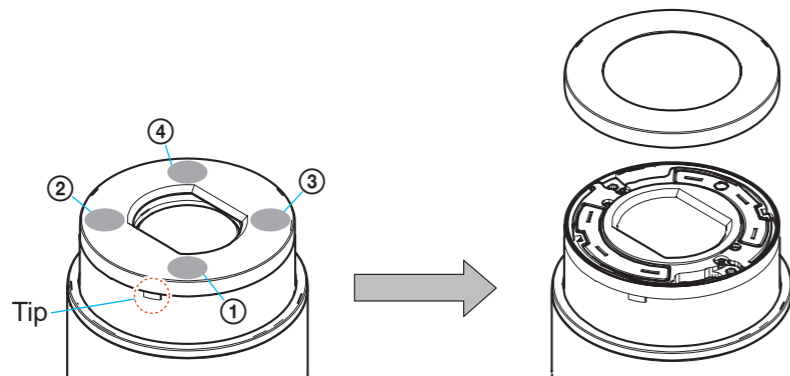

2-3-2. REMOVE OLD BARRIER ASSY

① Remove two screws.

* Discard the removed screws.

② Remove the Barrier Assy.

* Discard the removed Barrier Assy.

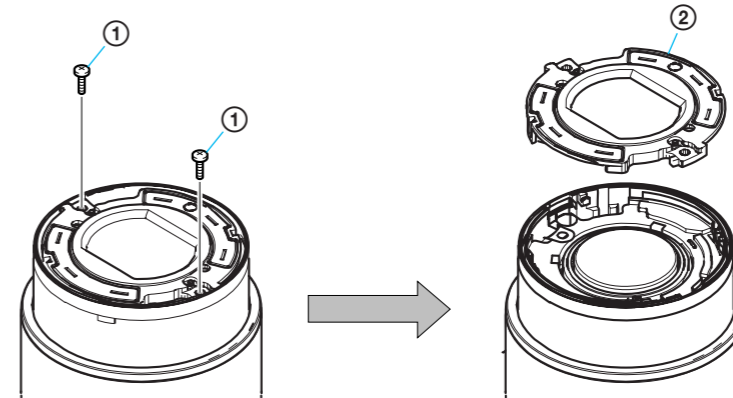

* After removing the Barrier Assy, if the "G1 Dust-Proof Ring" was removed, it must be returned to the home position.

In returning the ring, adjust the location of a projection to the lens direction.

This is an important part to prevent the dust and light from coming in.

* After removing the Barrier Assy, take extreme care not to drop dust or foreign substances in the lens barrel.

2-3-3. INSTALL NEW BARRIER ASSY

① Install new Barrier Assy by paying attention to the projection of the Barrier Assy in relation to the position shown in the under figure.

② Tighten two screws.

* Tightening torque = 0.5 kgf (4.9 N)

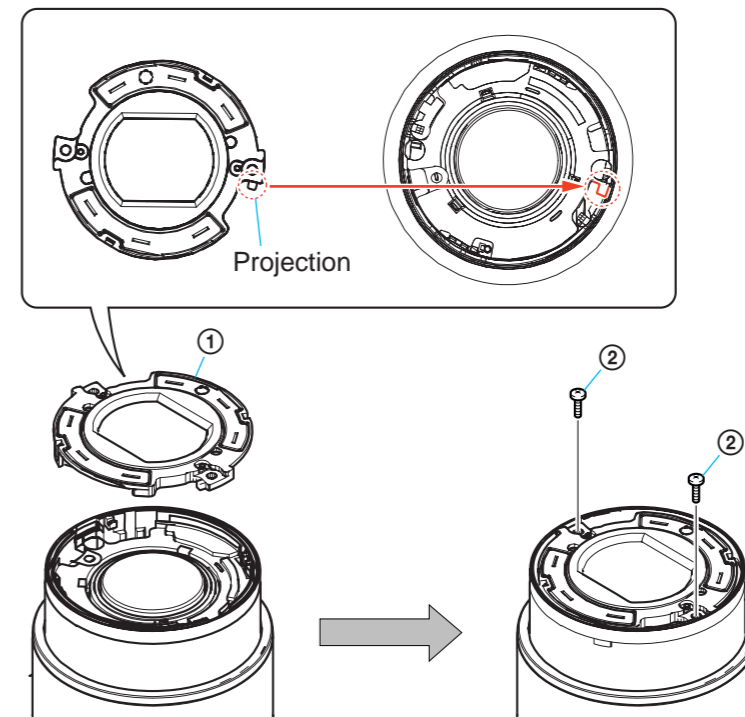

2-3-4. ADHERE THE ORNAMENTAL RING A

Apply an adhesive to four recesses on the top surface of the Barrier Assy.

* Do not apply too much adhesive. (Make quantity of adhesives into the quantity in which a groove hides.)

Meeting a "notch" of the Ornamental Ring A with a "projection" of the group-1 frame, push the Ornamental Ring A into the group-1 frame.

* The projection of the spring for preventing static electricity must be tilted.

Put the 60g weight on the Ornamental Ring A so that the Ornamental Ring A does not float up until the adhesive hardens.

Note: Be careful not to give a shock.

* After the weight was put, no gap must be present in full circumference between Ornamental Ring A and group-1 frame.

A gap, if present, causes the crackle sound NG.

* The weight must push in the Ornamental Ring A only.

If the weight is put on the mold part of the Barrier Assy, the Ornamental Ring A will float up.

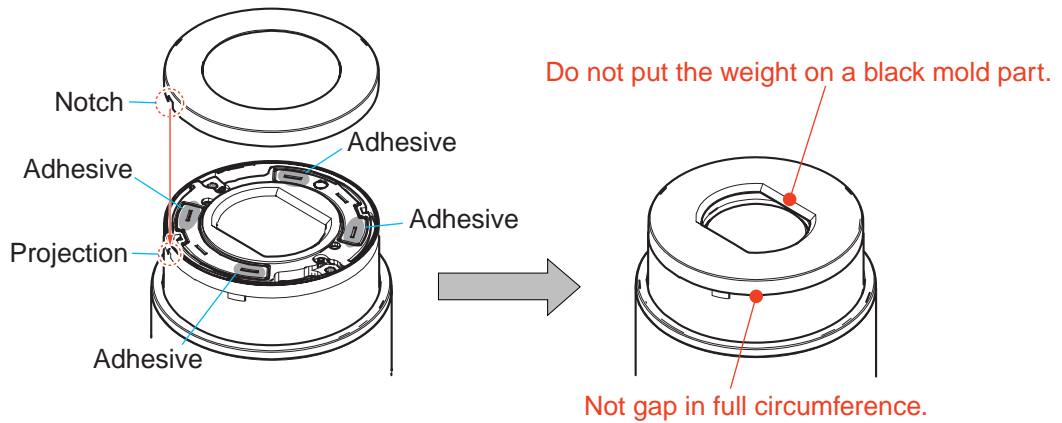

Completion after 30 minutes.

2-4. CIRCUIT BOARDS LOCATION

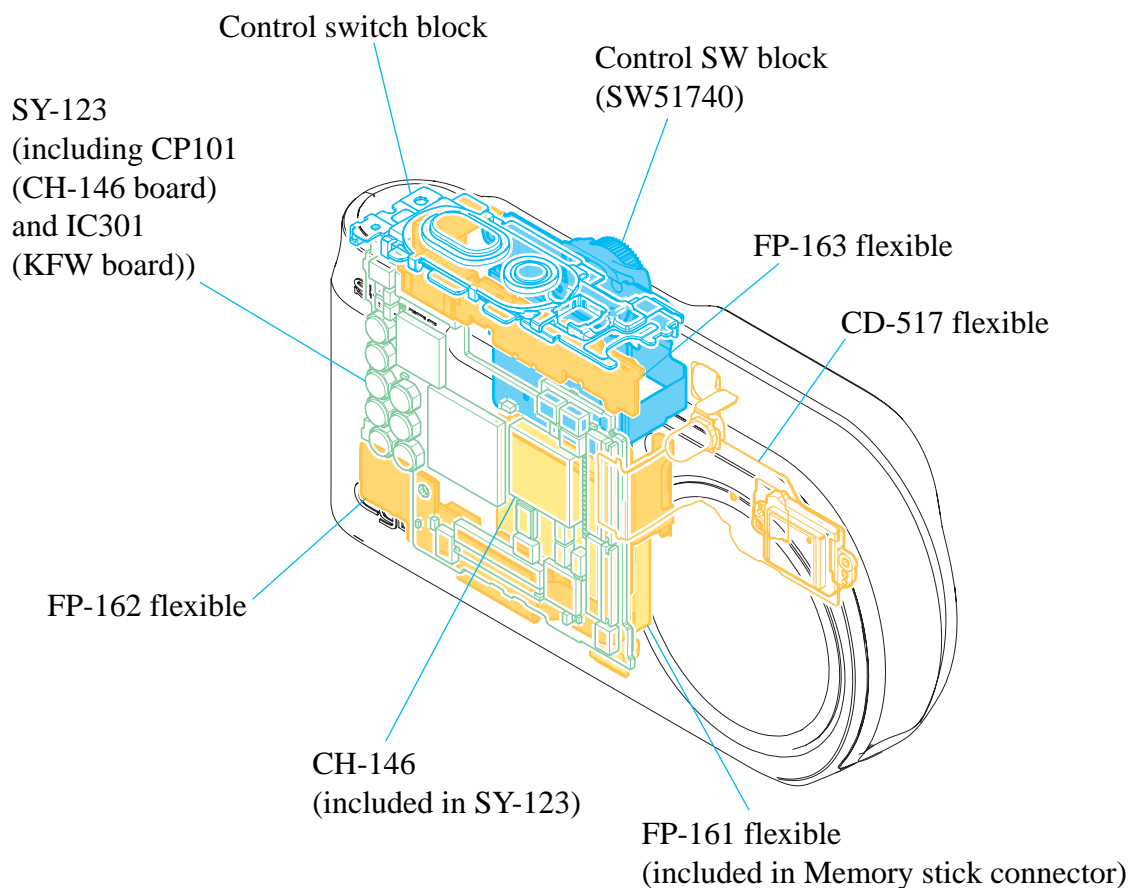

Board Name	Function
CD-517 flexible	CCD IMAGER
CH-146 (included in SY-123)	CCD SIGNAL PROCESS
FP-161 flexible (included in Memory stick connector)	MEMORY STICK CONNECTOR
FP-162 flexible	DC IN, MULTI CONNECTOR
FP-163 flexible	FLASH
SY-123 (including CP-101 (CH-146 board) and IC301 (KFW board))	CAMERA MODULE, CAMERA DSP, LENS DRIVE, SH DSP, FRONT CONTROL, LCD DRIVE, AUDIO, DC/DC CONVERTER, CONNECTOR

3. BLOCK DIAGRAMS

Link

• [OVERALL BLOCK DIAGRAM \(1/2\)](#)

• [POWER BLOCK DIAGRAM \(1/2\)](#)

• [OVERALL BLOCK DIAGRAM \(2/2\)](#)

• [POWER BLOCK DIAGRAM \(2/2\)](#)

3. BLOCK DIAGRAMS

3-1. OVERALL BLOCK DIAGRAM (1/2) () : Number in parenthesis () indicates the division number of schematic diagram where the component is located.

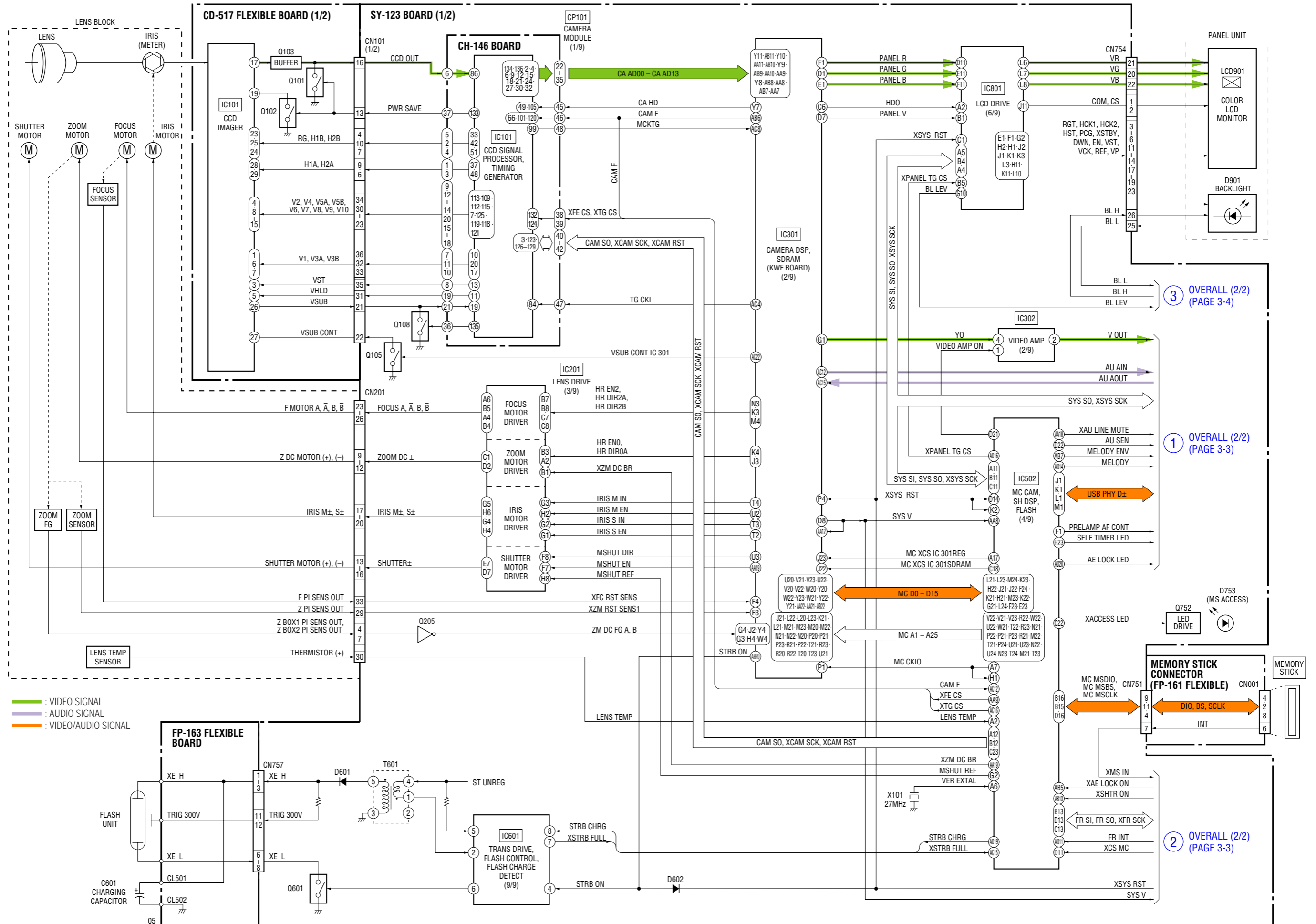

3-2. OVERALL BLOCK DIAGRAM (2/2) () : Number in parenthesis () indicates the division number of schematic diagram where the component is located.

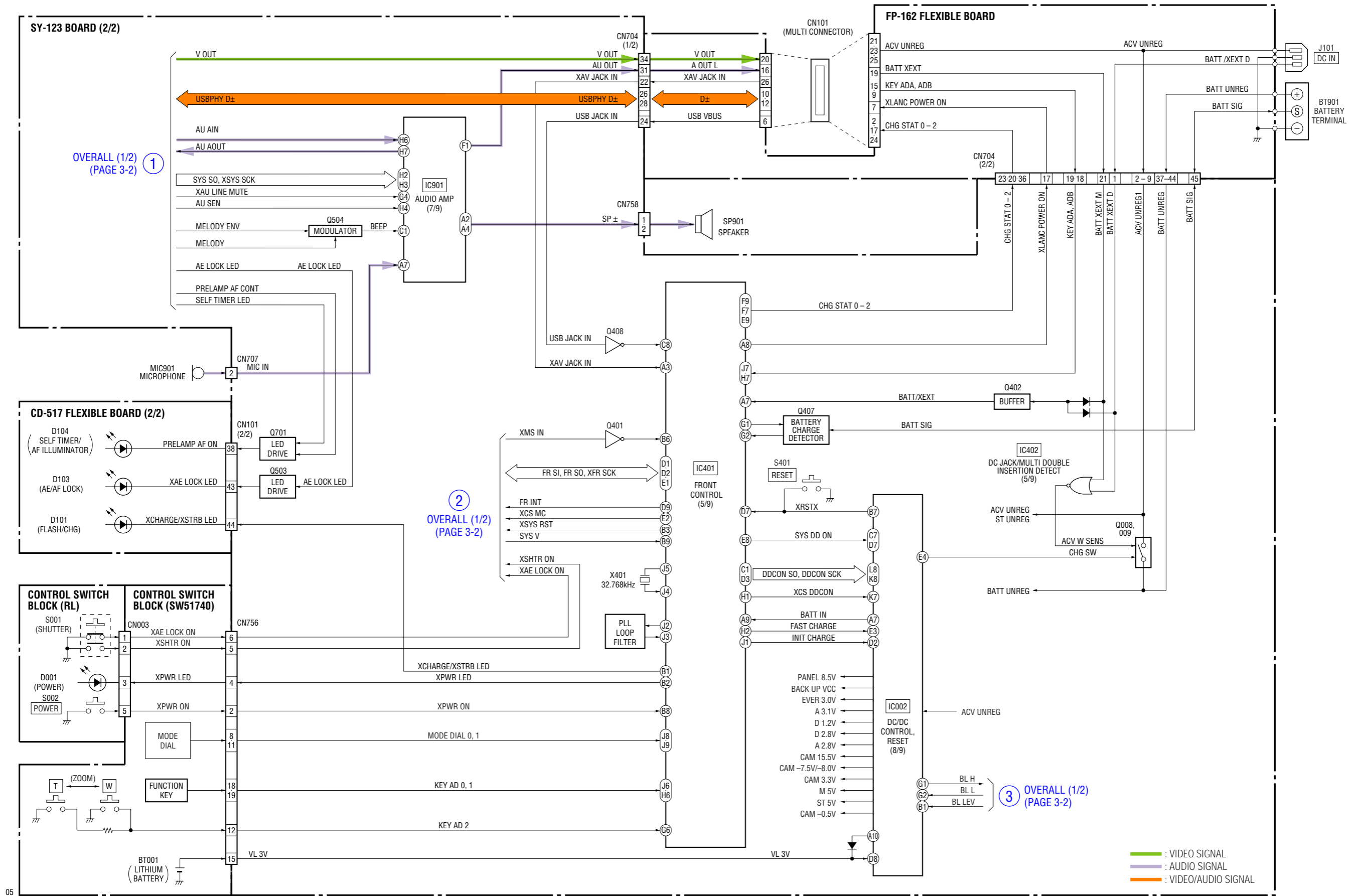

3-3. POWER BLOCK DIAGRAM (1/2) () : Number in parenthesis () indicates the division number of schematic diagram where the component is located.

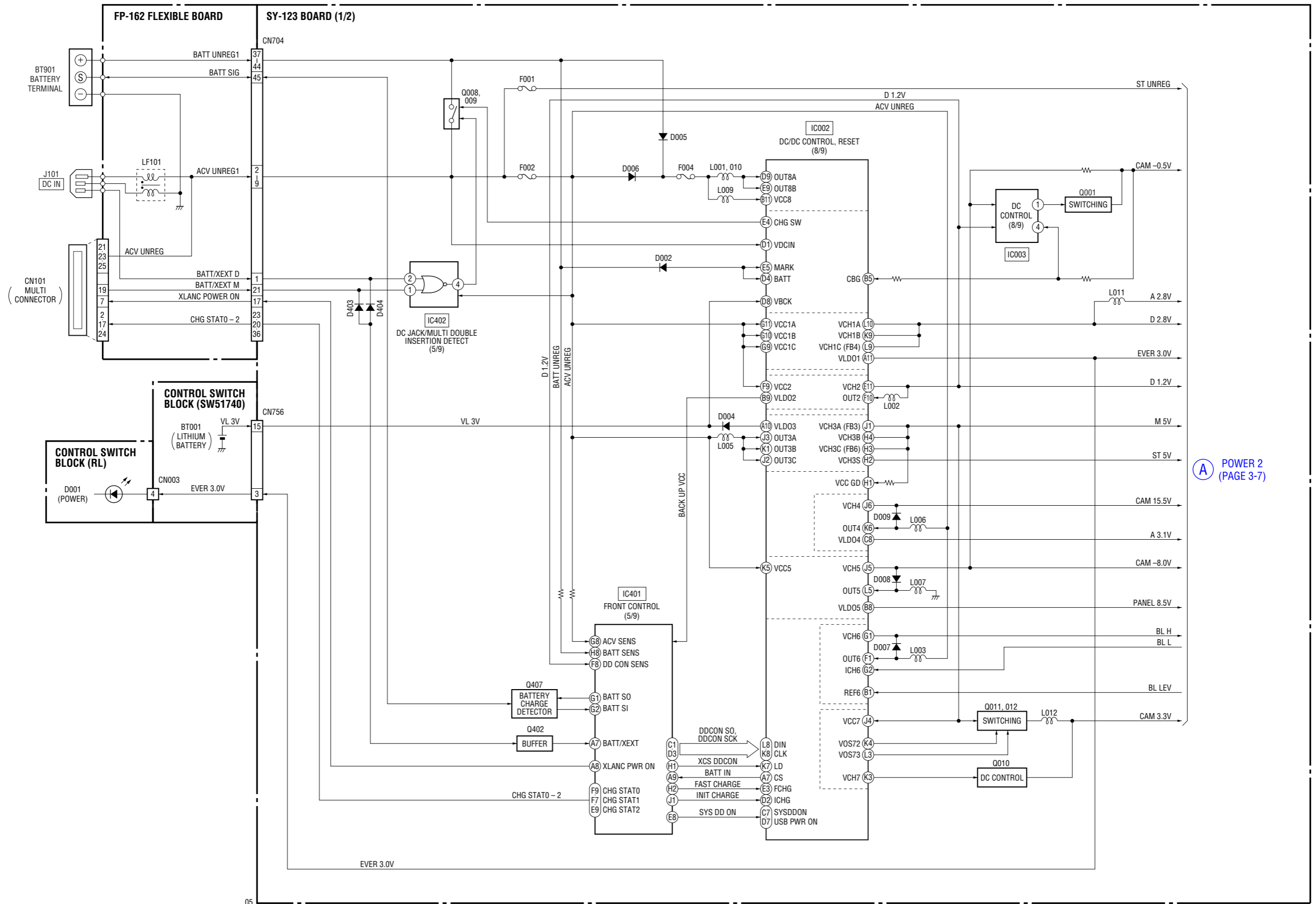

A POWER 2 (PAGE 3-7)

3-4. POWER BLOCK DIAGRAM (2/2) () : Number in parenthesis () indicates the division number of schematic diagram where the component is located.

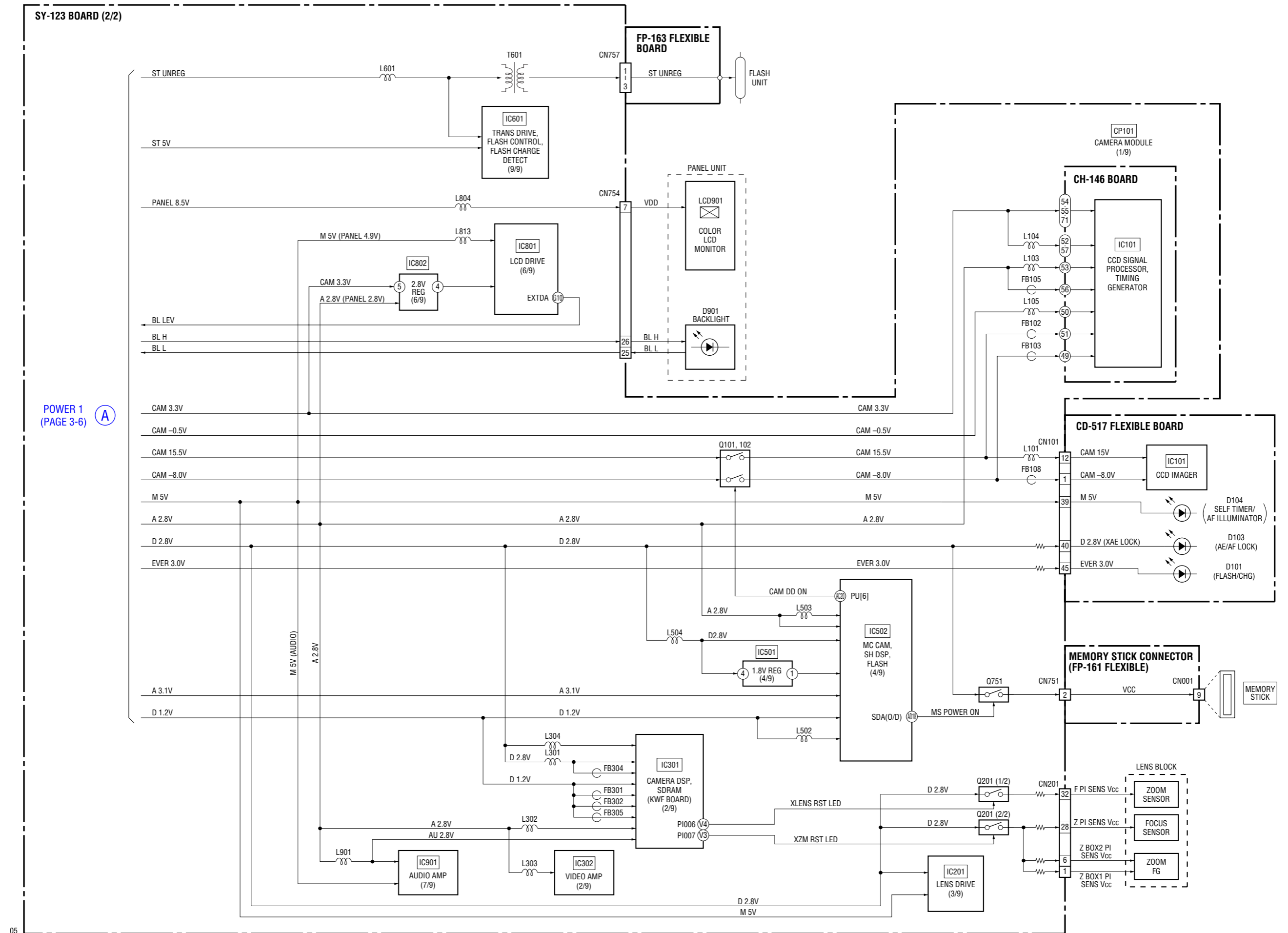

POWER 1 (PAGE 3-6) (A)

4. PRINTED WIRING BOARDS AND SCHEMATIC DIAGRAMS

4-1. FRAME SCHEMATIC DIAGRAM

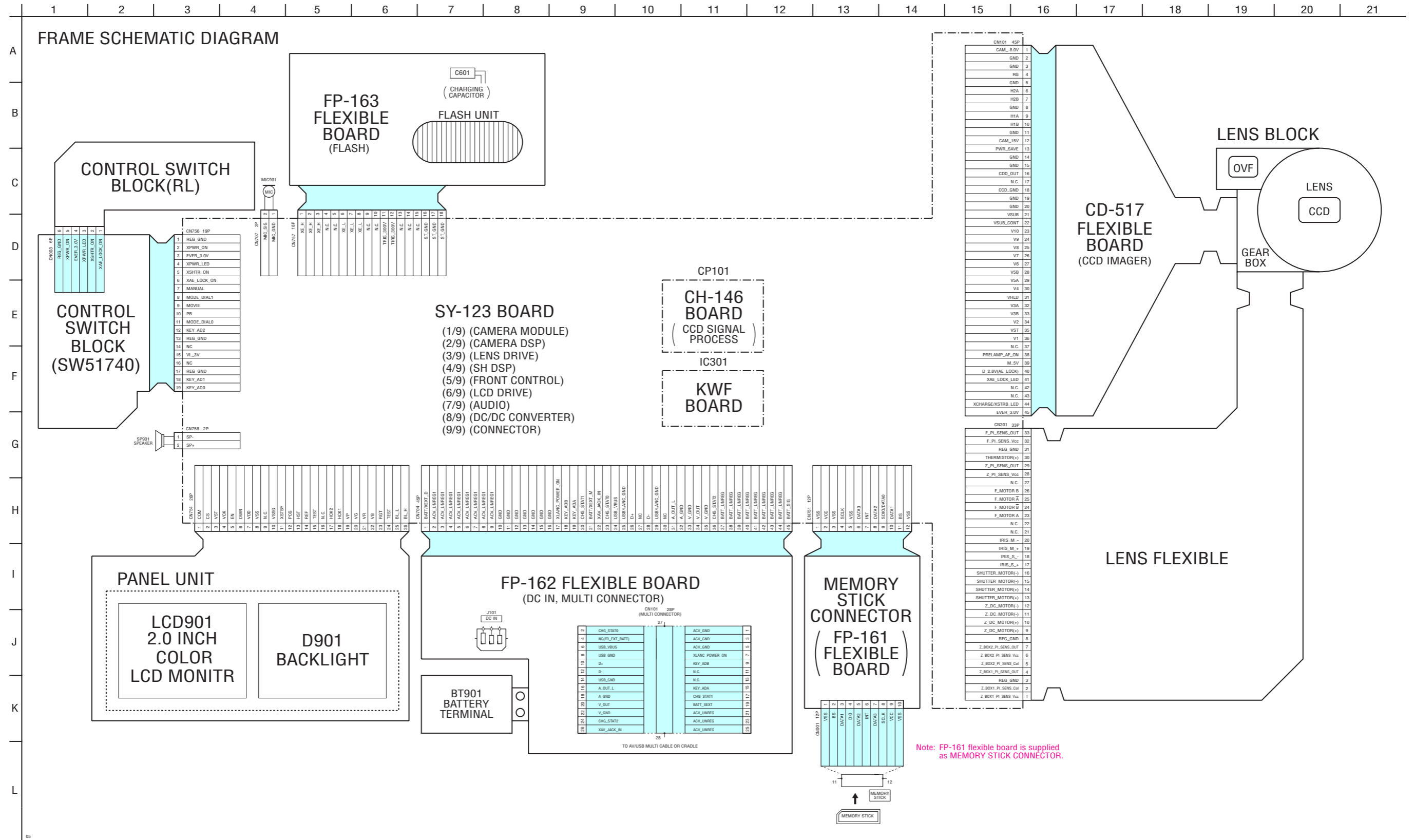

4-2. SCHEMATIC DIAGRAMS

Link

• [CD-517 FLEXIBLE \(CCD IMAGER\)](#)

• [FP-163 FLEXIBLE BOARD \(FLASH\)](#)

• [FP-162 FLEXIBLE BOARD
\(DC IN, MULTI CONNECTOR\)](#)

• [MEMORY STICK CONNECTOR
\(FP-161 FLEXIBLE\)](#)

• [COMMON NOTE FOR SCHEMATIC DIAGRAMS](#)

4-2. SCHEMATIC DIAGRAMS

4-2. SCHEMATIC DIAGRAMS

THIS NOTE IS COMMON FOR SCHEMATIC DIAGRAMS
(In addition to this, the necessary note is printed in each block)

(For schematic diagrams)

- All capacitors are in μF unless otherwise noted. pF : μF . 50 V or less are not indicated except for electrolytics and tantalums.
- Chip resistors are 1/10 W unless otherwise noted. $\text{k}\Omega=1000 \Omega$, $\text{M}\Omega=1000 \text{k}\Omega$.
- Caution when replacing chip parts. New parts must be attached after removal of chip. Be careful not to heat the minus side of tantalum capacitor, Because it is damaged by the heat.
- Some chip part will be indicated as follows.

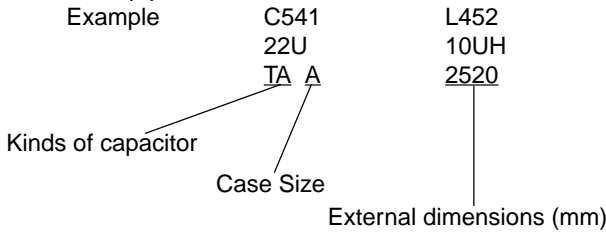

- Constants of resistors, capacitors, ICs and etc with XX indicate that they are not used. In such cases, the unused circuits may be indicated.
- Parts with ★ differ according to the model/destination. Refer to the mount table for each function.
- All variable and adjustable resistors have characteristic curve B, unless otherwise noted.
- Signal name
 $\text{XEDIT} \rightarrow \text{EDIT}$ $\text{PB/XREC} \rightarrow \text{PB/REC}$
- : non flammable resistor
- : fusible resistor
- : panel designation
- : B+ Line
- : B- Line
- : IN/OUT direction of (+,-) B LINE.
- : adjustment for repair.
- : not use circuit
- Circled numbers refer to waveforms.

(Measuring conditions voltage and waveform)

- Voltages and waveforms are measured between the measurement points and ground when camera shoots color bar chart of pattern box. They are reference values and reference waveforms. (VOM of DC 10 M Ω input impedance is used)
- Voltage values change depending upon input impedance of VOM used.)

Note : The components identified by mark Δ or dotted line with mark Δ are critical for safety. Replace only with part number specified.

1. Connection

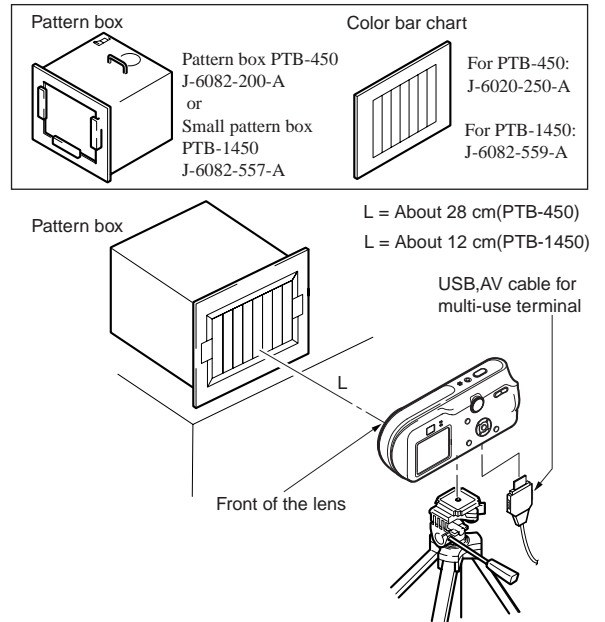

2. Adjust the distance so that the output waveform of Fig. a and the Fig. b can be obtain.

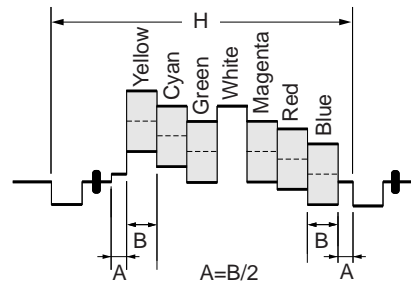

Fig. a (Video output terminal output waveform)

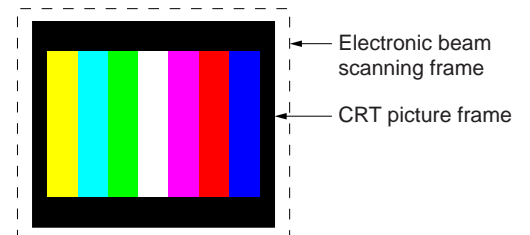

Fig.b (Picture on monitor TV)

When indicating parts by reference number, please include the board name.

Note : Les composants identifiés par une marque Δ sont critiques pour la sécurité. Ne les remplacer que par une pièce portant le numéro spécifiée.

For Schematic Diagram

• Refer to page 4-37 for printed wiring board.

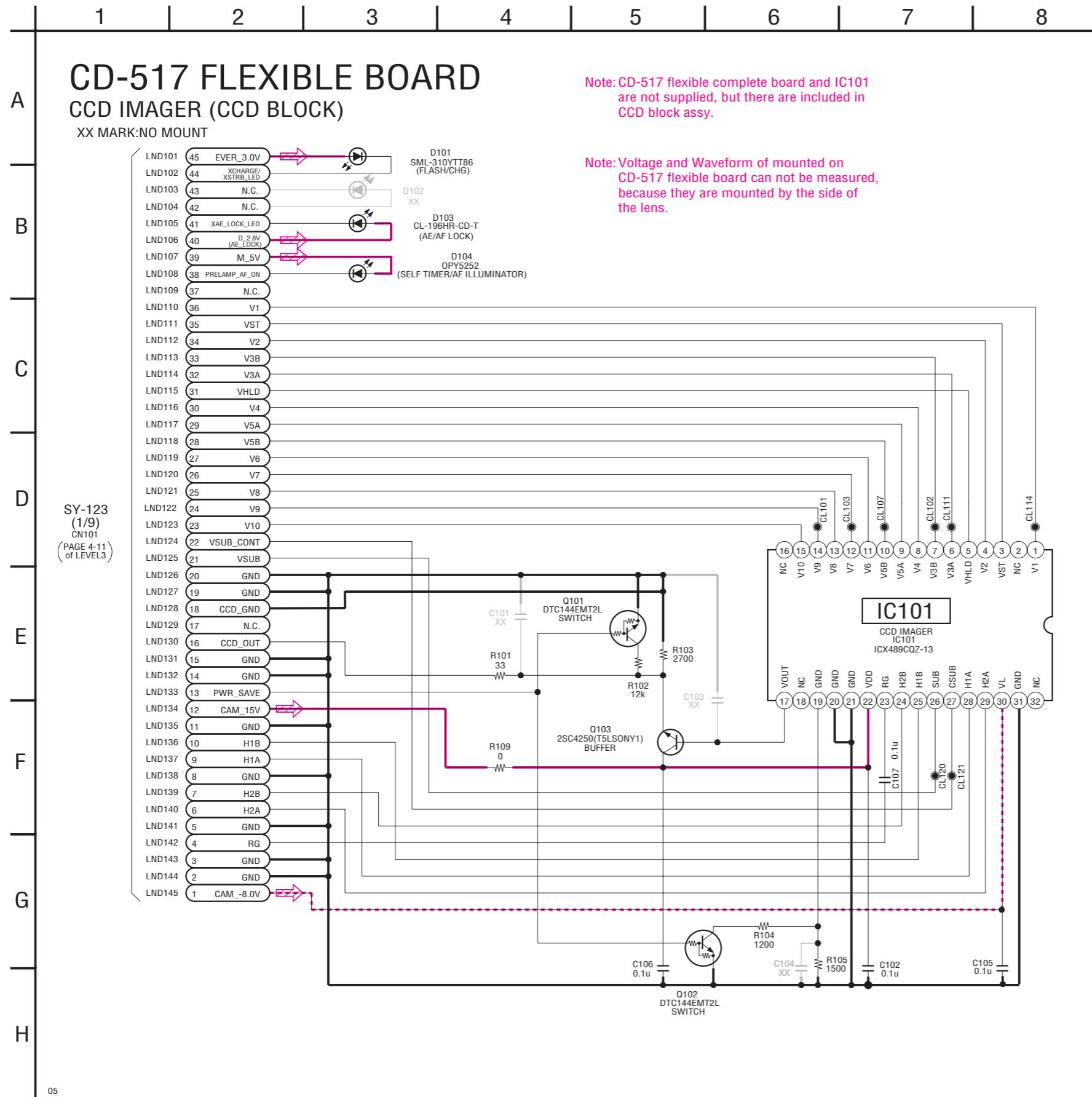

SY-123
(1/9)
CN101
(PAGE 4-11
of LEVEL3)

Precautions for Replacement of CCD Imager

- The CD-517 flexible board mounted as a repair part is not equipped with a CCD imager. When replacing this board, remove the CCD imager from the old one and mount it onto the new one.
- If the CCD imager has been replaced, carry out all the adjustments for the camera section.
- As the CCD imager may be damaged by static electricity from its structure, handle it carefully like for the MOS IC. In addition, ensure that the receiver is not covered with dusts nor exposed to strong light.

Schematic diagrams of the CH-146, SY-123 boards are not shown.
Pages from 4-9 to 4-28 are not shown.

For Schematic Diagram

• Refer to page 4-43 for printed wiring board.

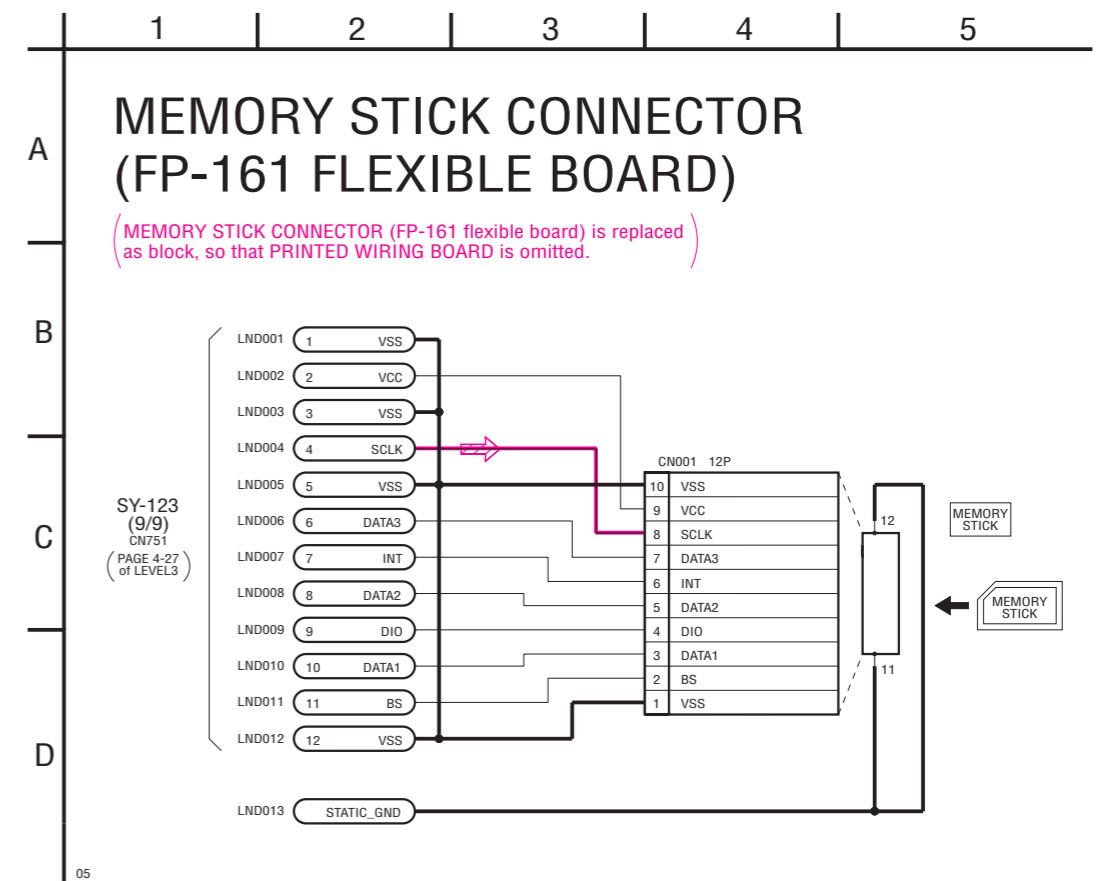
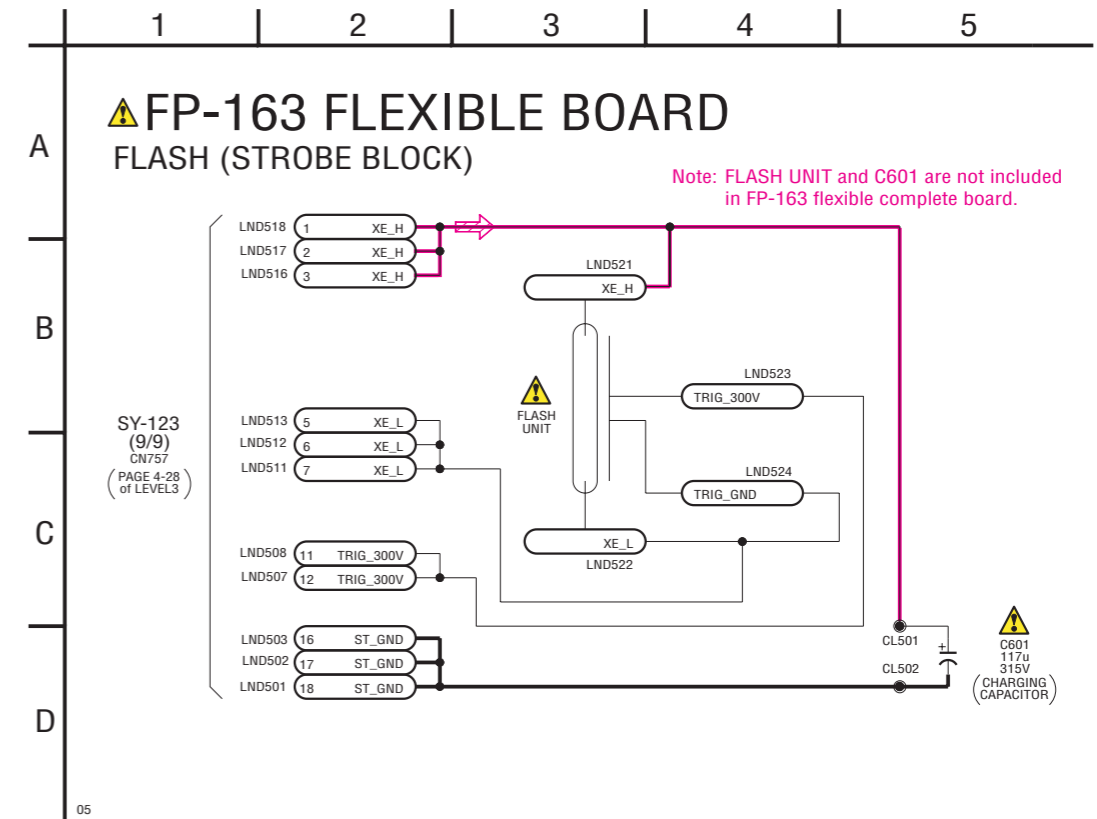
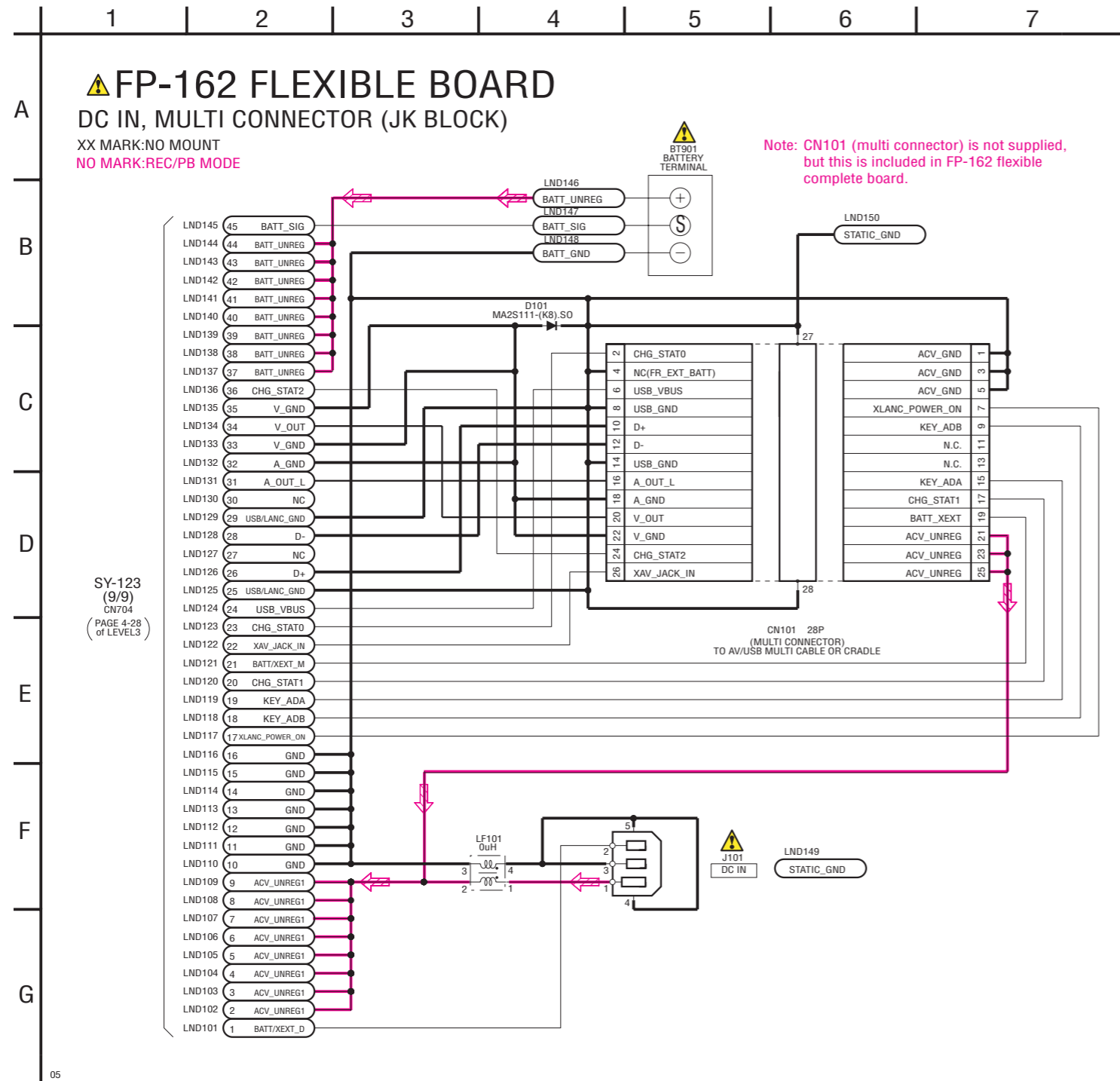

The components identified by mark \triangle or dotted line with mark \triangle are critical for safety. Replace only with part number specified.

Les composants identifiés par une marque \triangle sont critiques pour la sécurité. Ne les remplacer que par une pièce portant le numéro spécifié.

A
B
C
D
E
F
G
H
I
J
K

CONTROL SWITCH BLOCK (SW51740)

(CONTROL SWITCH BLOCK (SW51740) is replaced as block, so that PRINTED WIRING BOARD is omitted.)

SY-123
(5/9)
CN755
(PAGE 4-19
of LEVEL3)

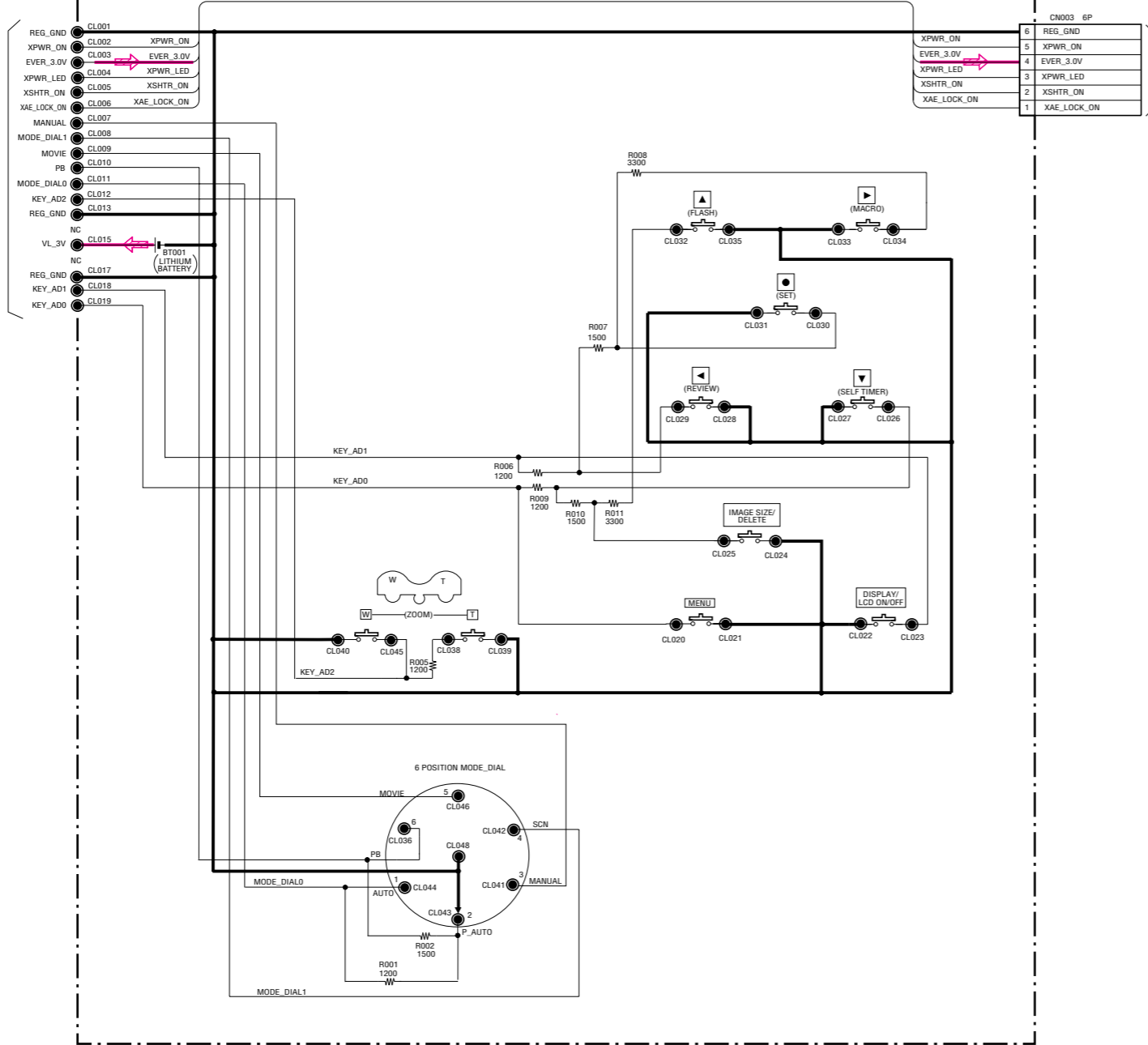

CONTROL SWITCH BLOCK (RL)

(CONTROL SWITCH BLOCK (RL) is replaced as block, so that PRINTED WIRING BOARD is omitted.)

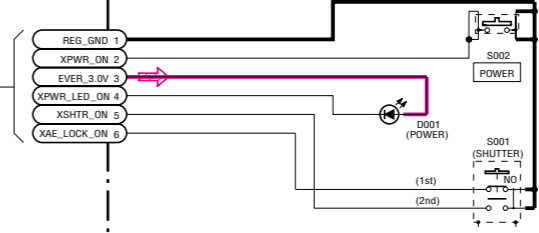

4-3. PRINTED WIRING BOARDS

Link

• [CD-517 FLEXIBLE BOARD](#)

• [FP-163 FLEXIBLE BOARD](#)

• [FP-162 FLEXIBLE BOARD](#)

• [COMMON NOTE FOR PRINTED WIRING BOARDS](#)

• [MOUNTED PARTS LOCATION](#)

• [CIRCUIT BOARDS LOCATION](#)

Board Name	Function
CD-517 flexible	CCD IMAGER
FP-162 flexible	DC IN, MULTI CONNECTOR
FP-163 flexible	FLASH

4-3. PRINTED WIRING BOARDS

4-3. PRINTED WIRING BOARDS

THIS NOTE IS COMMON FOR PRINTED WIRING BOARDS

- : Uses unleaded solder.
- : Circuit board
- : Flexible board
- : Pattern from the side which enables seeing.
- : pattern of the rear side
(The other layers' patterns are not indicated)
- Through hole is omitted.
- Circled numbers refer to waveforms.
- There are a few cases that the part printed on diagram isn't mounted in this model.
- : panel designation

• Chip parts.

Transistor

Diode

Board Name	Parts Location (Shown on Page)	Pattern	
		Total Number of Layers	Layers Not Indicated
CD-517 flexible	4-47	2 layers	–
FP-162 flexible	–	2 layers	–
FP-163 flexible	–	1 layer	–

CD-517 FLEXIBLE

Note for Printed Wiring Board (See page 4-35).

 : Uses unleaded solder.

CD-517 FLEXIBLE BOARD

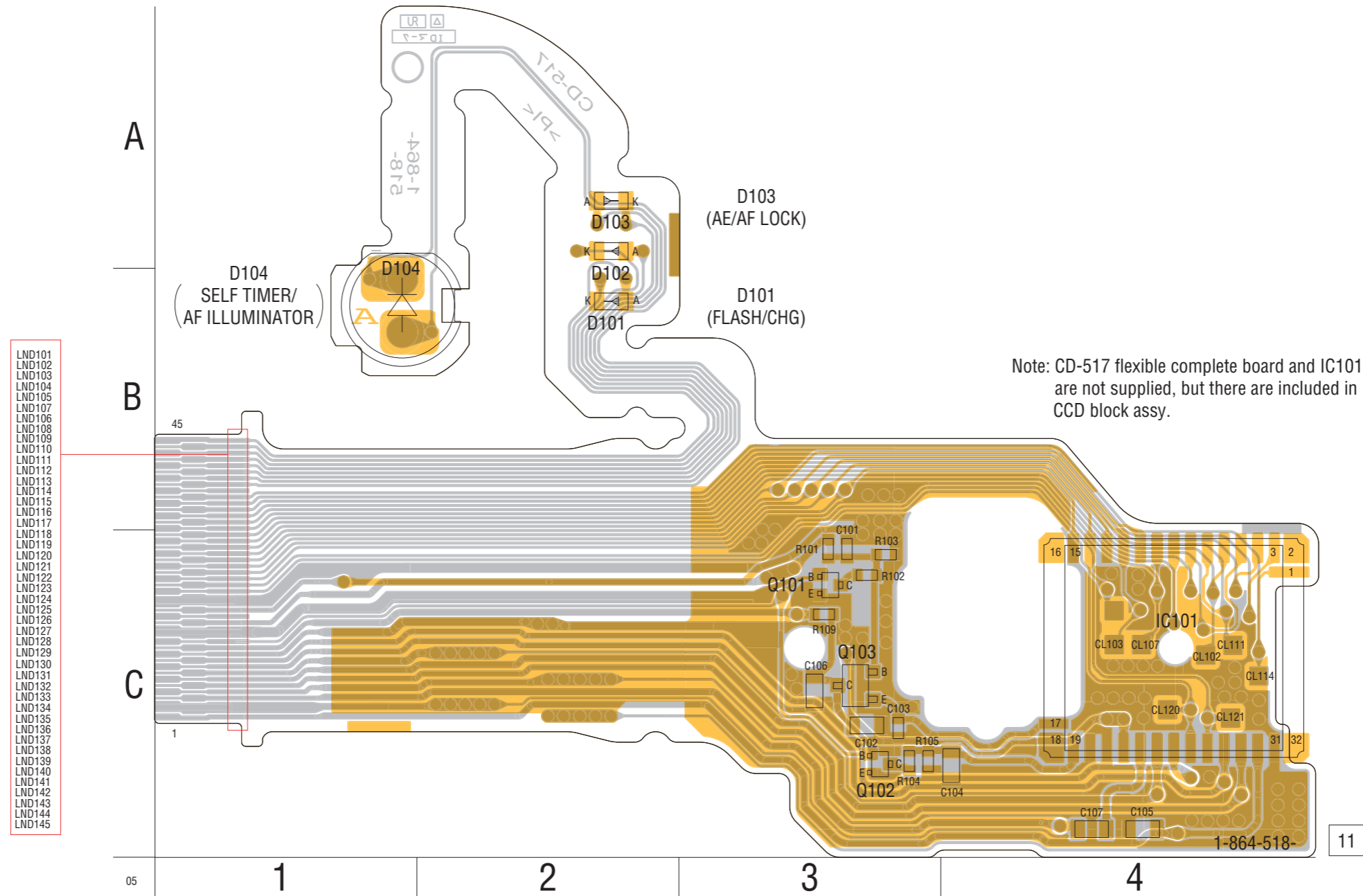

Printed wiring boards of the CH-146, SY-123 boards are not shown.
Pages from 4-39 to 4-42 are not shown.

Note for Printed Wiring Board (See page 4-35).

FP-162 FLEXIBLE

 : Uses unleaded solder.

FP-162 FLEXIBLE BOARD

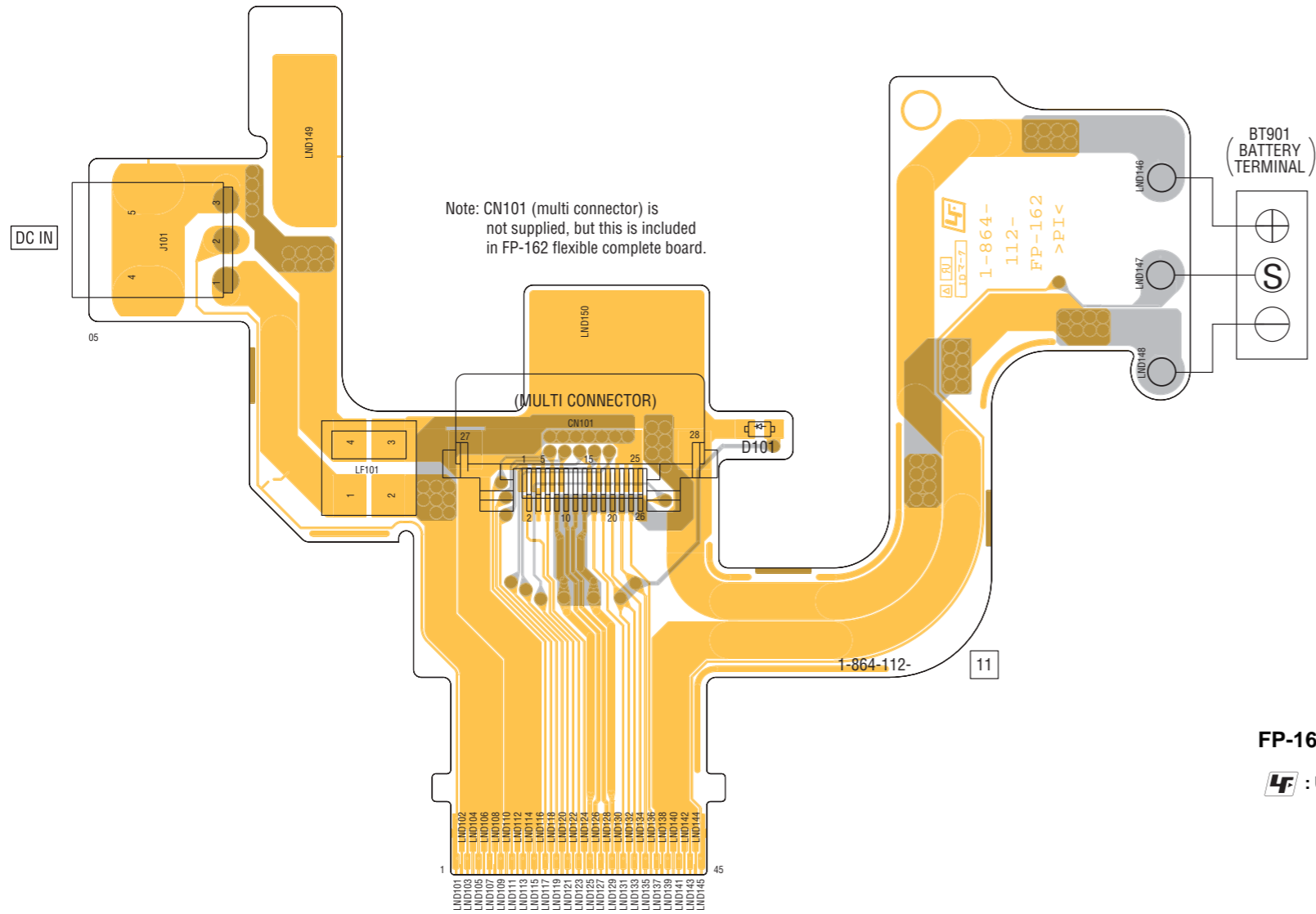

FP-163 FLEXIBLE

 : Uses unleaded solder.

FP-163 FLEXIBLE BOARD

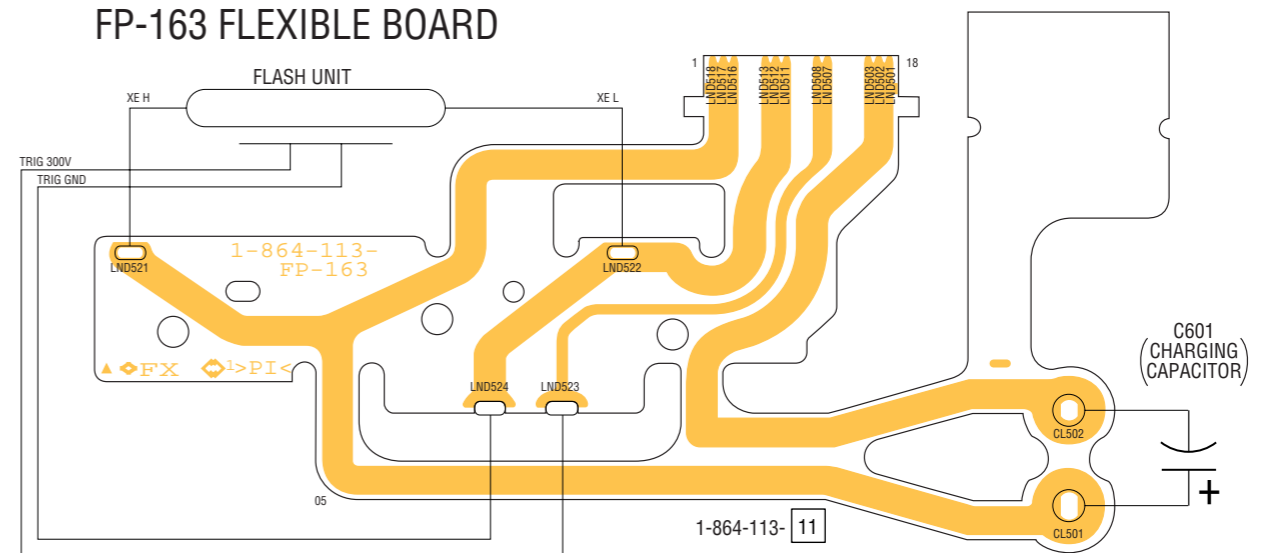

Waveforms of the SY-123 board are not shown.
Pages 4-45 and 4-46 are not shown.

4-3. PRINTED WIRING BOARDS

4-5. MOUNTED PARTS LOCATION

no mark : side A
* mark : side B

CD-517 FLEXIBLE BOARD

C102 C-3
C105 C-4
C106 C-3
C107 C-4

D101 B-2
D103 A-2
D104 B-1

IC101 C-4

Q101 C-3
Q102 C-3
Q103 C-3

R101 C-3
R102 C-3
R103 C-3
R104 C-3
R105 C-3
R109 C-3

Mounted parts location of the CH-146 and SY-123 boards are not shown.
Page 4-48 and 4-49 are not shown.

5. REPAIR PARTS LIST

NOTE: Characters **A** to **Z** of the electrical parts list indicate location of exploded views in which the desired part is shown.

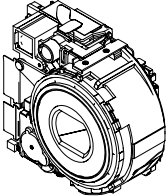
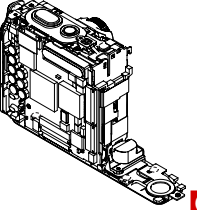
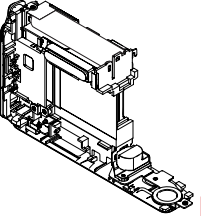
Link	EXPLODED VIEWS		
 <p data-bbox="485 730 507 757">A</p> <p data-bbox="244 786 501 819">OVERALL ASSEMBLY</p>	 <p data-bbox="804 730 826 757">B</p> <p data-bbox="560 786 826 819">LENS BLOCK ASSEMBLY</p>	 <p data-bbox="1123 730 1145 757">C</p> <p data-bbox="879 786 1145 819">MAIN BLOCK ASSEMBLY</p>	 <p data-bbox="1442 730 1465 757">D</p> <p data-bbox="1198 786 1465 819">BT BLOCK ASSEMBLY</p>

Link	ELECTRICAL PARTS LIST		ACCESSORIES
<ul style="list-style-type: none"> CD-517 FLEXIBLE BOARD B 	<ul style="list-style-type: none"> FP-162 FLEXIBLE BOARD C 		
<ul style="list-style-type: none"> FP-161 FLEXIBLE BOARD C 	<ul style="list-style-type: none"> FP-163 FLEXIBLE BOARD D 		

5. REPAIR PARTS LIST

5. REPAIR PARTS LIST

NOTE:

- -XX, -X mean standardized parts, so they may have some differences from the original one.
- Items marked “*” are not stocked since they are seldom required for routine service. Some delay should be anticipated when ordering these items.
- The mechanical parts with no reference number in the exploded views are not supplied.
- Due to standardization, replacements in the parts list may be different from the parts specified in the diagrams or the components used on the set.
- CAPACITORS:
uF: μ F
- COILS
uH: μ H
- RESISTORS
All resistors are in ohms.
METAL: metal-film resistor
METAL OXIDE: Metal Oxide-film resistor
F: nonflammable
- SEMICONDUCTORS
In each case, u: μ , for example:
uA...: μ A... , uPA... , μ PA... ,
uPB... , μ PB... , μ PC... , μ PC... ,
uPD... , μ PD...
- Abbreviation
AR : Argentina model
AUS : Australian model
BR : Brazilian model
CH : Chinese model
CND : Canadian model
HK : Hong Kong model
JE : Tourist model
KR : Korean model

When indicating parts by reference number, please include the board name.

The components identified by mark \triangle or dotted line with mark \triangle are critical for safety. Replace only with part number specified.

Les composants identifiés par une marque \triangle sont critiques pour la sécurité. Ne les remplacer que par une pièce portant le numéro spécifié.

5. REPAIR PARTS LIST

5-1. EXPLODED VIEWS

5-1-1. OVERALL ASSEMBLY

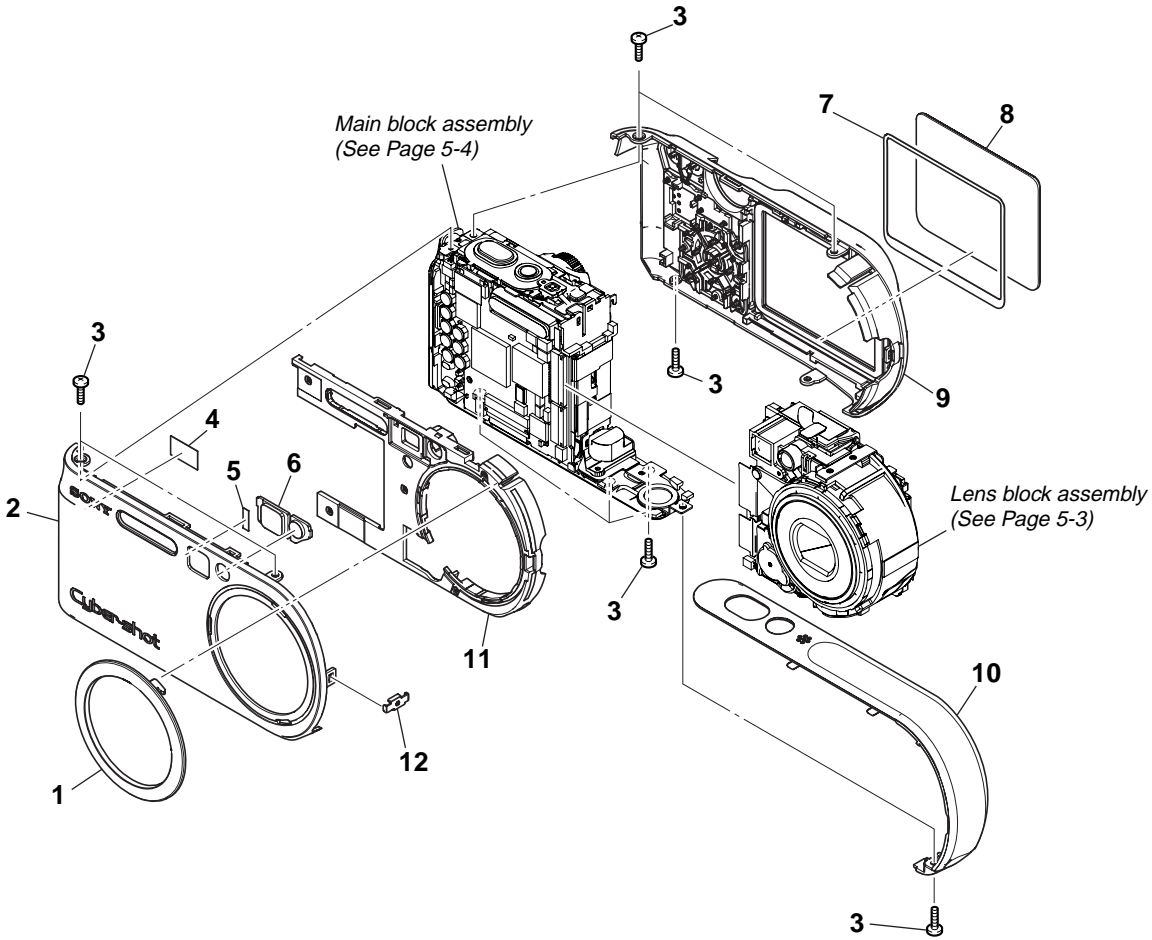

Ref. No.	Part No.	Description	Ref. No.	Part No.	Description
1	2-547-040-01	RING, LENS	7	2-582-186-01	SHEET, LCD WINDOW ADHESIVE
2	2-547-038-01	CABINET (FRONT (SD)) (SILVER)	8	2-582-185-01	WINDOW, LCD
2	2-547-038-11	CABINET (FRONT (SD)) (BLACK)	9	A-1097-047-A	CABINET (REAR) BLOCK ASSY (SILVER)
2	2-547-038-21	CABINET (FRONT (SD)) (BROWN)	9	A-1097-048-A	CABINET (REAR) BLOCK ASSY (BLACK)
3	2-587-151-01	SCREW (M1.4), NEW TRUSTAR.P2	9	A-1097-049-A	CABINET (REAR) BLOCK ASSY (BROWN)
4	2-582-197-01	SHEET (FRONT), ADHESIVE	10	X-2048-862-1	CABINET ASSY, SIDE
5	2-582-196-01	SHEET, OVF WINDOW ADHESIVE	11	2-582-194-01	CABINET (FRONT), INNER
6	2-582-195-01	WINDOW, OVF	12	2-582-184-01	PLATE, CABINET

5. REPAIR PARTS LIST

5-1-2. LENS BLOCK ASSEMBLY

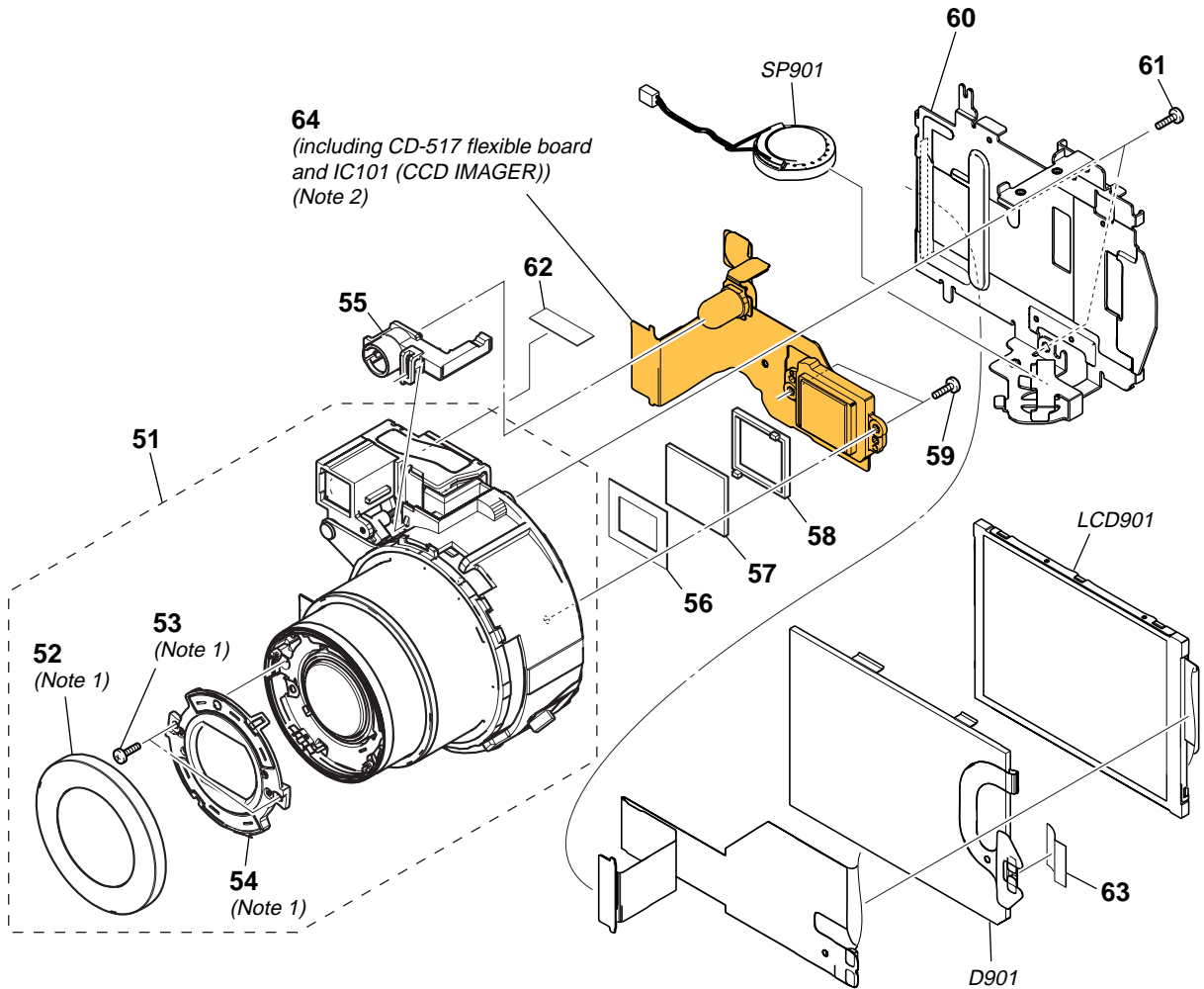

Note 1: Be sure to read "2-3. Exchange Method of Barrier Assy" on page 2-7 when change Ref. No. 52, 53 and 54.

Note 2: Be sure to read "Precautions for Replacement of CCD Imager" on page 4-8 when changing the CCD imager.

Ref. No.	Part No.	Description
51	1-788-208-11	LENS, VIDEO (EC01B)
52	3-091-427-01	RING (A), ORNAMENTAL (Note1)
53	3-086-156-31	SCREW, TAPPING (P2) (Note1)
54	X-3954-476-1	BARRIER ASSY (Note1)
55	3-091-013-01	HOLDER, AF
56	2-021-317-01	MASK, LPF
57	1-788-176-11	OPTICAL FILTERBLOCK (OFB-02-21)
58	2-021-318-01	SEALGOM 890
59	3-348-998-61	SCREW (M1.4X4), TAPPING, PAN

Ref. No.	Part No.	Description
60	2-582-219-01	FRAME, LENS
61	3-080-204-11	SCREW, TAPPING, P2
62	2-589-437-01	GUARD (CD), FLEXIBLE
63	2-582-218-01	SHEET, BL HARNESS PROTECTION
64	A-1089-498-A	CCD BLOCK ASSY (including CD-517 flexible board and IC101 (CCD IMAGER)) (Note2)
D901	1-479-010-11	BLOCK, LIGHT GUIDE PLATE (2.0)
LCD901	8-753-228-05	ACX335AK-3
SP901	1-825-923-31	LOUDSPEAKER (1.3CM)

5. REPAIR PARTS LIST

5-1-3. MAIN BLOCK ASSEMBLY

ns: not supplied

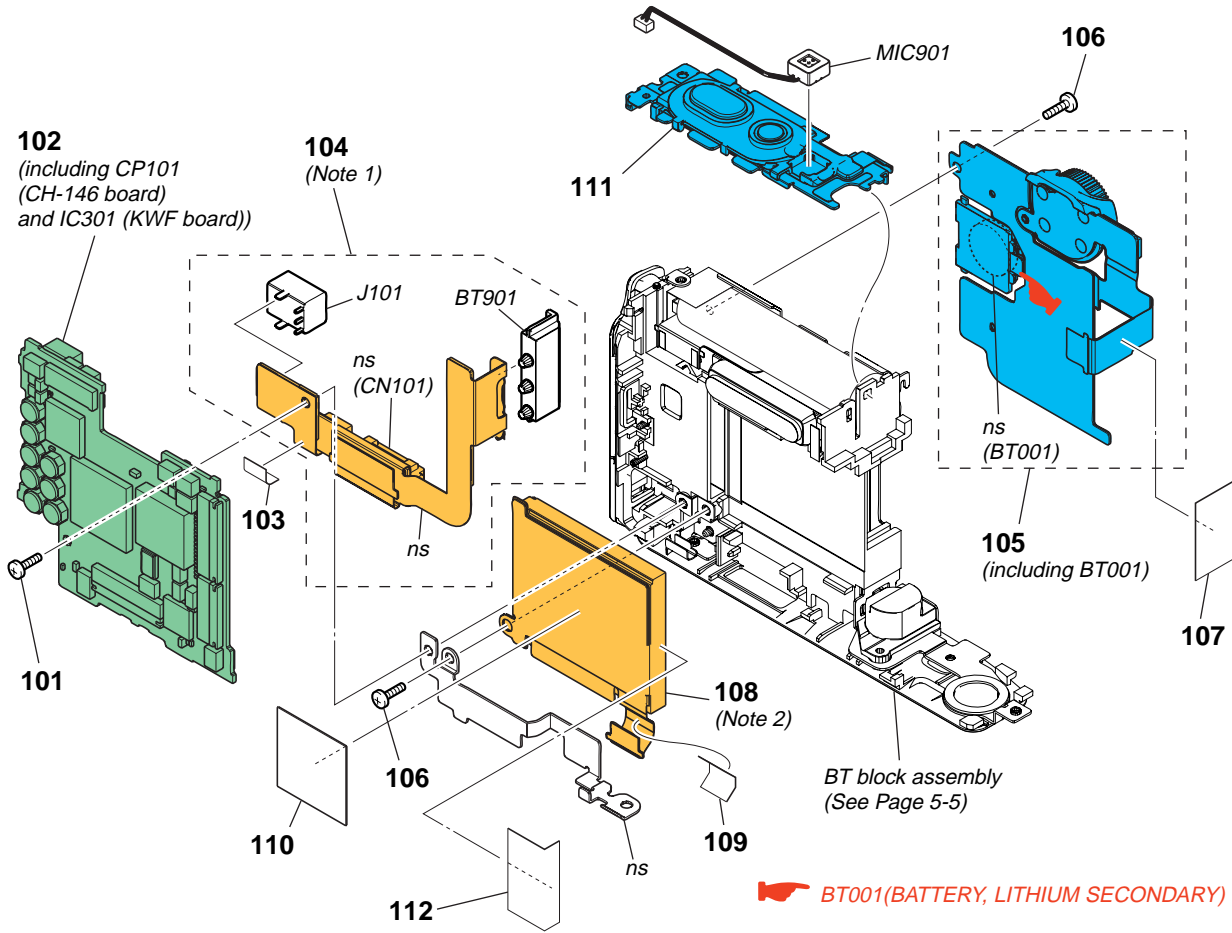

CAUTION
 Danger of explosion if battery is incorrectly replaced.
 Replace only with the same or equivalent type.

Note 1: CN101 (multi connector) is not supplied, but this is included in FP-162 flexible complete board.

Note 2: Part of 108 is including FP-161 flexible board.

The components identified by mark Δ or dotted line with mark Δ are critical for safety. Replace only with part number specified.	Les composants identifiés par une marque Δ sont critiques pour la sécurité. Ne les remplacer que par une pièce portant le numéro spécifié.
--	---

Ref. No.	Part No.	Description
101	3-080-222-31	SCREW (M1.7), TAPPING, P2
102	A-1107-528-A	SY-123 BOARD, COMPLETE (SERVICE) (including CP101 (CH-146 board) and IC301 (KWF board)) (E)
102	A-1107-529-A	SY-123 BOARD, COMPLETE (SERVICE) (including CP101 (CH-146 board) and IC301 (KWF board)) (HK, KR, CH, JE)
102	A-1107-533-A	SY-123 BOARD, COMPLETE (SERVICE) (including CP101 (CH-146 board) and IC301 (KWF board)) (US, CND, AUS)
102	A-1107-534-A	SY-123 BOARD, COMPLETE (SERVICE) (including CP101 (CH-146 board) and IC301 (KWF board)) (AEP, UK)
103	2-582-200-01	SHEET, JK

Ref. No.	Part No.	Description
Δ 104	A-1086-398-A	FP-162 FLEXIBLE BOARD, COMPLETE (Note 1)
105	1-479-099-11	CONTROL SW BLOCK (SW51740) (Including BT001)
106	3-080-204-11	SCREW, TAPPING, P2
107	2-582-202-01	SHEET, CCD RADIATION
108	1-819-094-11	CONNECTOR, MEMORY STICK 10P (Note 2)
109	2-582-205-01	SHEET, MS RADIATION
110	2-590-642-01	SHEET, SY RADIATION
111	1-479-100-11	SWITCH BLOCK, CONTROL
112	2-592-676-01	MS SPACER
Δ BT901	1-780-141-21	BATTERY TERMINAL BOARD
Δ J101	1-817-331-11	DC JACK 5P (DC IN)
MIC901	1-542-623-11	MICROPHONE UNIT

5. REPAIR PARTS LIST

5-1-4. BT BLOCK ASSEMBLY

ns: not supplied

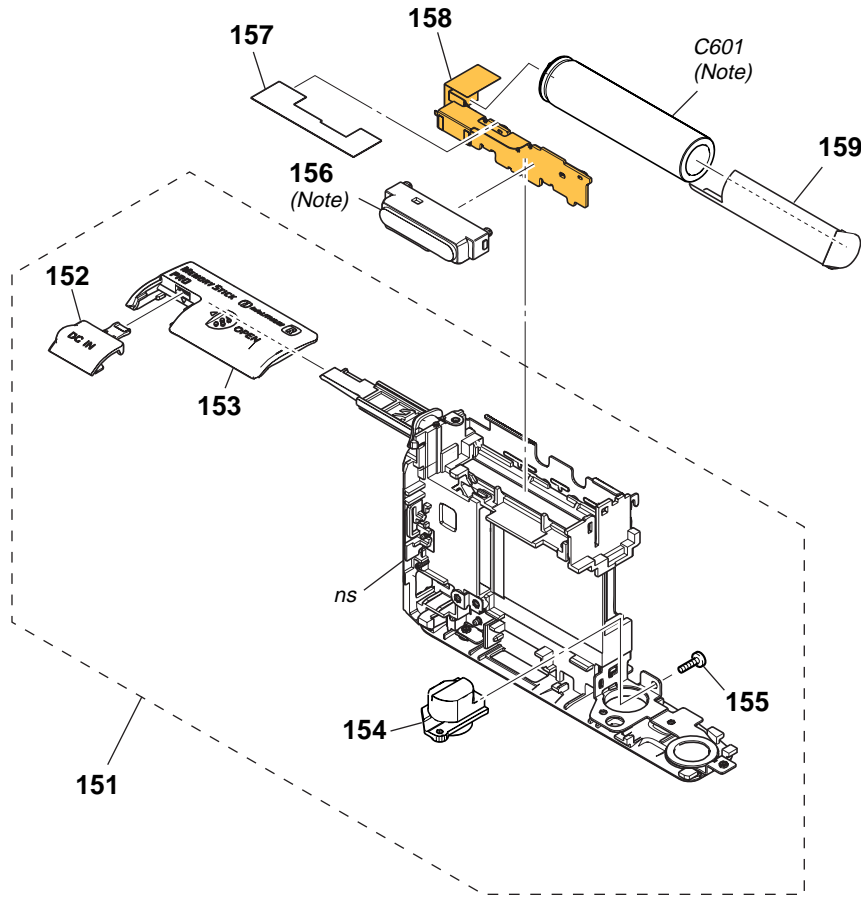

Note: FLASH UNIT and C601 are not included in FP-163 flexible board.

The components identified by mark Δ or dotted line with mark Δ are critical for safety. Replace only with part number specified.

Les composants identifiés par une marque Δ sont critiques pour la sécurité. Ne les remplacer que par une pièce portant le numéro spécifié.

Ref. No.	Part No.	Description
151	X-2048-864-1	HOLDER ASSY, BATTERY (SILVER)
151	X-2048-866-1	HOLDER ASSY, BATTERY (BLACK)
151	X-2048-867-1	HOLDER ASSY, BATTERY (BROWN)
152	2-547-035-01	LID, DC JACK (SILVER)
152	2-547-035-11	LID, DC JACK (BLACK)
152	2-547-035-21	LID, DC JACK (BROWN)
153	2-547-036-01	LID, BATTERY (SILVER)
153	2-547-036-11	LID, BATTERY (BLACK)
153	2-547-036-21	LID, BATTERY (BROWN)

Ref. No.	Part No.	Description
154	2-582-212-01	SCREW, TRIPOD
155	2-587-151-01	SCREW (M1.4), NEW TRUSTAR.P2
Δ 156	1-478-674-11	FLASH UNIT (Note)
157	2-582-204-01	SHEET, STROBOSCOPE INSULATING
Δ 158	1-864-113-11	FP-163 FLEXIBLE BOARD
159	2-590-582-01	SHEET, CAPACITOR INSULATING
Δ C601	1-100-969-11	CAP, ELECT 117uF 315V (Note)

5-2. ELECTRICAL PARTS LIST

Ref. No.	Part No.	Description
	A-1089-498-A	CCD BLOCK ASSY (Not supplied) CD-517 FLEXIBLE BOARD, COMPLETE ***** (CCD block assy is including CD-517 flexible board and IC101 (CCD imager).)
		< CAPACITOR >
C102	1-107-826-11	CERAMIC CHIP 0.1uF 10% 16V
C105	1-107-826-11	CERAMIC CHIP 0.1uF 10% 16V
C106	1-107-826-11	CERAMIC CHIP 0.1uF 10% 16V
C107	1-107-826-11	CERAMIC CHIP 0.1uF 10% 16V
		< DIODE >
D101	8-719-077-34	DIODE SML-310YTT86 (FLASH/CHG)
D103	8-719-075-29	DIODE SML-510MWT86S (AE/AF LOCK)
D104	6-500-505-01	DIODE OPY5052 (SELF TIMER/AF ILLUMINATOR)
		< IC >
IC101	(Not supplied)	ICX489CQZ-13 (Note)
		< TRANSISTOR >
Q101	6-550-119-01	TRANSISTOR DTC144EMT2L
Q102	6-550-119-01	TRANSISTOR DTC144EMT2L
Q103	8-729-050-22	TRANSISTOR 2SC4250 (T5LSONY1)
		< RESISTOR >
R101	1-218-935-11	RES-CHIP 33 5% 1/16W
R102	1-218-966-11	RES-CHIP 12K 5% 1/16W
R103	1-218-958-11	RES-CHIP 2.7K 5% 1/16W
R104	1-218-954-11	RES-CHIP 1.2K 5% 1/16W
R105	1-218-955-11	RES-CHIP 1.5K 5% 1/16W
R109	1-218-990-11	SHORT CHIP 0
	1-819-094-11	CONNECTOR, MEMORY STICK 10P (Not supplied) FP-161 FLEXIBLE BOARD ***** (Memory stick connector is including FP-161 flexible board.)
△	A-1086-398-A	FP-162 FLEXIBLE BOARD, COMPLETE ***** (This flexible complete board is including CN101 (multi connector).)
△ BT901	1-780-141-21	BATTERY TERMINAL BOARD < CONNECTOR >
CN101	(Not supplied)	CONNECTOR, MULTIPLE (SOCKET) < DIODE >
D101	8-719-056-23	DIODE MA2S111-(K8).SO < JACK >
△ J101	1-817-331-11	DC JACK 5P (DC IN)

Ref. No.	Part No.	Description
		< LINE FILTER >
LF101	1-456-681-21	COIL, CHOKE
△	1-864-113-11	FP-163 FLEXIBLE BOARD ***** (FLASH UNIT and C601 are not included in this flexible board.)
△	1-478-674-11	FLASH UNIT < CAPACITOR >
△ C601	1-100-969-11	CAP, ELECT 117uF 315V

Electrical parts list of the CH-146 and SY-123 boards are not shown. Pages 5-7 to 5-11 are not shown.

(Note) Be sure to read "Precautions for Replacement of CCD Imager" on page 4-8 when changing the CCD imager.

The components identified by mark △ or dotted line with mark △ are critical for safety. Replace only with part number specified.

Les composants identifiés par marque △ sont critiques pour la sécurité. Ne les remplacer que par une pièce portant le numéro spécifié.

Checking supplied accessories.

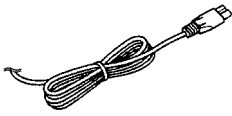

Power cord (1)
 ▲ 1-769-608-31 (AEP, E)
 ▲ 1-782-476-13 (CH)
 ▲ 1-783-374-12 (UK, HK)
 ▲ 1-790-107-22 (US, CND)
 ▲ 1-790-732-12 (JE)
 ▲ 1-823-947-12 (KR)
 ▲ 1-827-945-12 (AUS)

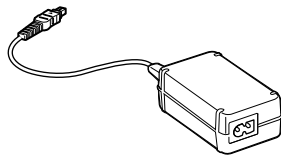

AC adaptor
 AC-LS5/LS5B (1)
 ▲ 1-477-730-51

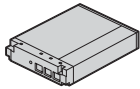

NP-FR1 battery pack (1)
 (not supplied)



Wrist strap (1)
 2-050-981-01

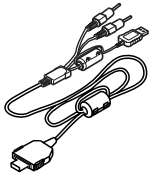

USB, AV cable for
 multi-use terminal (1)
 1-829-866-11

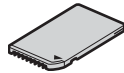

"Memory Stick" (32MB) (1)
 (not supplied)

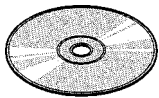

CD-ROM
 (Cyber-shot application software) (1)
 2-583-852-01 (US)
 2-583-853-01
 (CND, AEP, UK, E, HK, KR, AUS, JE)
 2-583-854-01 (CH)



Conversion adaptor (1)
 ▲ 1-569-008-21 (E)



Conversion adaptor (1)
 ▲ 1-569-007-11 (E, JE)

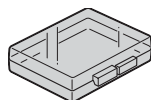

Battery case (1)
 (not supplied)

Other accessories

- 2-582-853-11 INSTRUCTION (READ THIS FIRST) (ENGLISH)
 (EXCEPT AEP, KR, CH)
- 2-582-853-21 INSTRUCTION (READ THIS FIRST)
 (FRENCH, ITALIAN) (CND, AEP)
- 2-582-853-31 INSTRUCTION (READ THIS FIRST)
 (SPANISH, PORTUGUESE) (AEP, E, JE)
- 2-582-853-41 INSTRUCTION (READ THIS FIRST)
 (GERMAN, DUTCH) (AEP)
- 2-582-853-51 INSTRUCTION (READ THIS FIRST)
 (TRADITIONAL CHINESE, SIMPLIFIED CHINESE)
 (E, HK, CH, JE)
- 2-582-853-61 INSTRUCTION (READ THIS FIRST)
 (RUSSIAN, SWEDISH) (AEP)
- 2-582-853-71 INSTRUCTION (READ THIS FIRST)
 (ARABIC, PERSIAN) (E)
- 2-582-853-81 INSTRUCTION (READ THIS FIRST) (KOREAN)
 (KR, JE)
- 2-582-853-91 INSTRUCTION (READ THIS FIRST) (POLISH, CZECH)
 (AEP)
- 2-582-854-11 INSTRUCTION (READ THIS FIRST)
 (HUNGARIAN, SLOVAKIAN) (AEP)
- 2-582-856-11 INSTRUCTION (USER'S GUIDE) (ENGLISH)
 (EXCEPT AEP, AR, KR, BR, CH)
- 2-582-856-21 INSTRUCTION (USER'S GUIDE) (FRENCH, ITALIAN)
 (CND, AEP)
- 2-582-856-31 INSTRUCTION (USER'S GUIDE)
 (SPANISH, PORTUGUESE) (AEP, E, JE)
- 2-582-856-41 INSTRUCTION (USER'S GUIDE) (GERMAN, DUTCH)
 (AEP)
- 2-582-856-51 INSTRUCTION (USER'S GUIDE)
 (TRADITIONAL CHINESE, SIMPLIFIED CHINESE)
 (E, HK, CH, JE)
- 2-582-856-61 INSTRUCTION (USER'S GUIDE)
 (RUSSIAN, SWEDISH) (AEP)
- 2-582-856-71 INSTRUCTION (USER'S GUIDE) (ARABIC, PERSIAN)
 (E)
- 2-582-856-81 INSTRUCTION (USER'S GUIDE) (KOREAN) (KR, JE)
- 2-582-856-91 INSTRUCTION (USER'S GUIDE) (POLISH, CZECH)
 (AEP)
- 2-582-857-11 INSTRUCTION (USER'S GUIDE)
 (HUNGARIAN, SLOVAKIAN) (AEP)

The components identified by mark ▲ or dotted line with mark ▲ are critical for safety. Replace only with part number specified.

Les composants identifiés par une marque ▲ sont critiques pour la sécurité. Ne les remplacer que par une pièce portant le numéro spécifié.

[Description of main button functions on toolbar of the Adobe Acrobat Reader Ver5.0 (for Windows)]

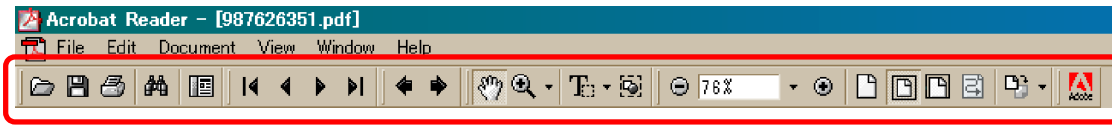

Toolbar



Printing a text

1. Click the Print button .
2. Specify a printer, print range, number of copies, and other options, and then click [OK].

Application of printing:

To set a range to be printed within a page, select the graphic selection tool  and drag on the page to enclose a range to be printed, and then click the Print button.

Reversing the screens displayed once

- To reverse the previous screens (operation) one by one, click the .
- To advance the reversed screens (operation) one by one, click the .

Application to the Service Manual:

This function allows you to go and back between circuit diagram and printed circuit board diagram, and accordingly it will be convenient for the voltage check.

Finding a text

1. Click the Find button .
2. Enter a character string to be found into a text box, and click the [Find]. (Specify the find options as necessary)

Application to the Service Manual:

To execute “find” from current page toward the previous pages, select the check box “Find Backward” and then click the “Find”.

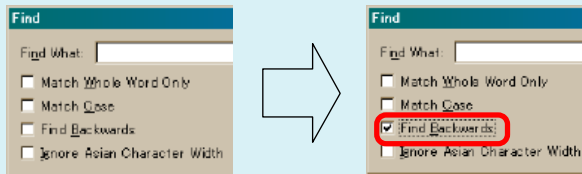





3. Open the find dialog box again, and click the [Find Again] and you can find the matched character strings displayed next. (Character strings entered previously are displayed as they are in the text box.)

Application to the Service Manual:

The parts on the drawing pages (block diagrams, circuit diagrams, printed circuit boards) and parts list pages in a text can be found using this find function. For example, find a Ref. No. of IC on the block diagram, and click the [Find Again] continuously, so that you can move to the Ref. No. of IC on the circuit diagram or printed circuit board diagram successively.

Note: The find function may not be applied to the Service Manual depending on the date of issue.

Moving with link

1. Select either palm tool , zoom tool , text selection tool , or graphic selection tool .
2. Place the pointer in the position in a text where the link exists (such as a button on cover and the table of contents page, or blue characters on the removal flowchart page or drawing page), and the pointer will change to the forefinger form .
3. Then, click the link. (You will go to the link destination.)

Moving with bookmark:

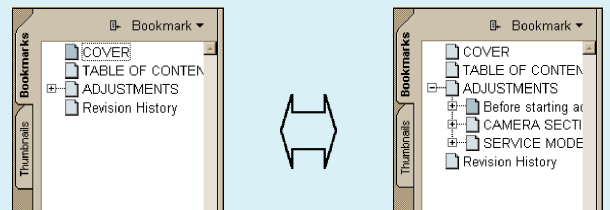

Click an item (text) on the bookmark pallet. and you can move to the link destination. Also, clicking  can display the hidden items.

(To go back to original state, click )



Zooming or rotating the screen display

“Zoom in/out”

- Click the triangle button in the zoom control box to select the display magnification. Or, you may click  or  for zooming in or out.

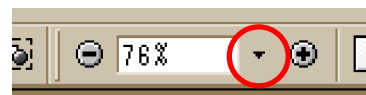





“Rotate”

- Click rotate tool , and the page then rotates 90 degrees each.

Application to the Service Manual:

The printed circuit board diagram you see now can be changed to the same direction as the set.

Switching a page

- To move to the first page, click the .
- To move to the last page, click the .
- To move to the previous page, click the .
- To move to the next page, click the .

Revision History

Ver.	Date	History	Contents	S.M. Rev. issued
1.0	2005.01	Official Release	—	—