

DSC-P10/P12

SERVICE MANUAL

LEVEL 2

Ver 1.0 2003.03

Revision History



Photo: DSC-P10

US Model
Canadian Model
DSC-P10
AEP Model
UK Model
DSC-P10/P12
E Model
Hong Kong Model
Australian Model
Chinese Model
Korea Model
Tourist Model
Japanese Model
DSC-P10

Link

SPECIFICATIONS	BLOCK DIAGRAMS	PRINTED WIRING BOARDS
SERVICE NOTE	FRAME SCHEMATIC DIAGRAMS	REPAIR PARTS LIST
DISASSEMBLY	SCHEMATIC DIAGRAMS	

- For ADJUSTMENTS (SECTION 6), refer to SERVICE MANUAL, ADJ (987622751.pdf).
- For INSTRUCTION MANUAL, refer to SERVICE MANUAL, LEVEL 1 (987622741.pdf).
- This service manual contains information for Japanese model as well.
- **Reference No. search on printed wiring boards is available.**
- [Note in Lens Frame Installation](#)
- [HELP: Sheet attachment positions and procedures of processing the flexible boards/harnesses are shown.](#)

On the JK-243, JK-244 and SY-83 boards

This service manual provides the information that is premised the circuit board replacement service and not intended repair inside the JK-243, JK-244 and SY-83 boards.

Therefore, schematic diagram, printed wiring board and electrical parts list of the JK-243, JK-244 and SY-83 boards are not shown.

The following pages are not shown.

JK-243, JK-244 boards

Schematic diagram Pages 4-35 to 4-36
Printed wiring board Pages 4-51 to 4-52
Electrical parts list Pages 5-6

SY-83 board

Schematic diagram Pages 4-9 to 4-28
Printed wiring board Pages 4-43 to 4-46
Electrical parts list Pages 5-9 to 5-13

The above-described information is shown in service manual Level 3.

DIGITAL STILL CAMERA

SONY®



Cyber-shot
Digital Still Camera



SPECIFICATIONS

■ Camera

[System]

Image device

9,04 mm (1/1.8 type) color CCD
Primary color filter

Total pixels number of camera

Approx. 5 250 000 pixels

Effective pixels number of camera

Approx. 5 090 000 pixels

Lens

3× zoom lens
f = 7.9 – 23.7 mm (5/16 –
15/16 inches) (38 – 114 mm
(1 1/2 – 4 1/2 inches) when converted
to a 35 mm still camera)
F2.8 – 5.2

Exposure control

Automatic exposure, Scene selection
(7 modes)

White balance

Flash, Automatic, Daylight, Cloudy,
Fluorescent, Incandescent

Data format (DCF compliant)

Still images: Exif Ver. 2.2 JPEG
compliant, GIF (for Clip Motion),
DPOF compatible
Audio with still image:
MPEG1 compliant (Monaural)
Moving images:
MPEG1 compliant (Monaural)

Recording media

“Memory Stick”

Flash

Recommended distance (ISO set to Auto):
0.5 m to 3.5 m (19 3/4 inches to
11 feet 5 3/16 inches) (W)
0.6 m to 2.5 m (23 5/8 inches to 8 feet
2 7/16 inches) (T)

[Output connectors]

A/V OUT (MONO) (Monaural)

Mini-jack
Video: 1 Vp-p, 75 Ω, unbalanced,
sync negative
Audio: 327 mV (at a 47 kΩ load)
Output impedance 2.2 kΩ

USB jack mini-B

[LCD screen]

Used LCD panel

3.8 cm (1.5 type) TFT drive

Total number of dots

123 200 (560×220) dots

[General]

Used battery pack

NP-FC11

Power requirements

3.6 V

Power consumption (during shooting)

1.6 W

Operating temperature

0°C to 40°C (32°F to 104°F)

Storage temperature

–20°C to +60°C (–4 °F to +140°F)

Dimensions

108×51.5×35.1 mm
(4 3/8×2 1/8×1 7/16 inches)
(W/H/D, excluding maximum
protrusions)

Mass

Approx. 200 g (7 oz) (including
battery pack NP-FC11, “Memory
Stick” and wrist strap)

Built-in microphone

Electret condenser microphone

Built-in speaker

Dynamic speaker

Exif Print Compatible

PRINT image matching II Compatible

■ AC-LS5 AC Adaptor

Rated input voltage

100 to 240 V AC, 50/60 Hz, 11 W,
0.16 to 0.09 A

Rated output voltage

DC 4.2 V, 1.5 A in operating mode

Operating temperature

0°C to 40°C (32°F to 104°F)

Storage temperature

–20°C to +60°C (–4 °F to +140°F)

Dimensions

Approx. 48×29×81 mm
(1 15/16×1 3/16×3 1/4 inches)
(W/H/D)

Mass

Approx. 130 g (5 oz)

■ NP-FC11 battery pack

Used battery

Lithium-ion battery

Maximum voltage

DC 4.2 V

Nominal voltage

DC 3.6 V

Capacity 2.8 Wh (780 mAh)

Accessories

- NP-FC11 battery pack (DSC-P12: 2, DSC-P10: 1)
- AC-LS5 AC Adaptor
- Power cord (mains lead)
- A/V connecting cable
- USB cable
- Wrist strap
- “Memory Stick” (32 MB)
- CD-ROM (USB driver SPVD-010)
- Operating instructions
- Soft carrying case (DSC-P12 only)

Design and specifications are subject to change
without notice.

SAFETY-RELATED COMPONENT WARNING!!

COMPONENTS IDENTIFIED BY MARK \triangle OR DOTTED LINE WITH MARK \triangle ON THE SCHEMATIC DIAGRAMS AND IN THE PARTS LIST ARE CRITICAL TO SAFE OPERATION. REPLACE THESE COMPONENTS WITH SONY PARTS WHOSE PART NUMBERS APPEAR AS SHOWN IN THIS MANUAL OR IN SUPPLEMENTS PUBLISHED BY SONY.

ATTENTION AU COMPOSANT AYANT RAPPORT À LA SÉCURITÉ!

LES COMPOSANTS IDENTIFIÉS PAR UNE MARQUE \triangle SUR LES DIAGRAMMES SCHÉMATIQUES ET LA LISTE DES PIÈCES SONT CRITIQUES POUR LA SÉCURITÉ DE FONCTIONNEMENT. NE REMPLACER CES COMPOSANTS QUE PAR DES PIÈCES SONY DONT LES NUMÉROS SONT DONNÉS DANS CE MANUEL OU DANS LES SUPPLÉMENTS PUBLIÉS PAR SONY.

SAFETY CHECK-OUT

After correcting the original service problem, perform the following safety checks before releasing the set to the customer.

1. Check the area of your repair for unsoldered or poorly-soldered connections. Check the entire board surface for solder splashes and bridges.
2. Check the interboard wiring to ensure that no wires are "pinched" or contact high-wattage resistors.
3. Look for unauthorized replacement parts, particularly transistors, that were installed during a previous repair. Point them out to the customer and recommend their replacement.
4. Look for parts which, through functioning, show obvious signs of deterioration. Point them out to the customer and recommend their replacement.
5. Check the B+ voltage to see it is at the values specified.
6. Flexible Circuit Board Repairing
 - Keep the temperature of the soldering iron around 270°C during repairing.
 - Do not touch the soldering iron on the same conductor of the circuit board (within 3 times).
 - Be careful not to apply force on the conductor when soldering or unsoldering.

Unleaded solder

Boards requiring use of unleaded solder are printed with the lead-free mark (LF) indicating the solder contains no lead. (Caution: Some printed circuit boards may not come printed with the lead free mark due to their particular size.)

**: LEAD FREE MARK**

Unleaded solder has the following characteristics.

- Unleaded solder melts at a temperature about 40°C higher than ordinary solder. Ordinary soldering irons can be used but the iron tip has to be applied to the solder joint for a slightly longer time. Soldering irons using a temperature regulator should be set to about 350°C. Caution: The printed pattern (copper foil) may peel away if the heated tip is applied for too long, so be careful!
- Strong viscosity. Unleaded solder is more viscous (sticky, less prone to flow) than ordinary solder so use caution not to let solder bridges occur such as on IC pins, etc.
- Usable with ordinary solder. It is best to use only unleaded solder but unleaded solder may also be added to ordinary solder.

TABLE OF CONTENTS

<u>Section</u>	<u>Title</u>	<u>Page</u>
1. SERVICE NOTE		
1-1.	Note for Repair	1-1
1-2.	Discharging of the ST-81 Flexible Board's Charging Capacitor (C001)	1-1
1-3.	Precaution on Replacing the Video Lens or the SY-83 Board	1-2
1-4.	Note in Lens Frame Installation	1-2
1-5.	Description on Self-diagnosis Display	1-3
2. DISASSEMBLY		
2-1.	Battery Lid	2-3
2-2.	Cabinet (Rear) Assembly	2-3
2-3.	LCD Module	2-4
2-4.	Cabinet Front Assembly	2-4
2-5.	Control Switch Block	2-5
2-6.	Cabinet (Lower) Assembly	2-6
2-7.	Lens Block Assembly	2-6
2-8.	ST-81 Board	2-7
2-9.	SY-83 Board	2-7
2-10.	MS-130 Board	2-8
2-11.	SW-386 Board	2-8
2-12.	JK-244 Board	2-9
2-13.	CD-434 Board	2-9
2-14.	Circuit Boards Location	2-10
3. BLOCK DIAGRAMS		
3-1.	Overall Block Diagram (1/2)	3-1
3-2.	Overall Block Diagram (2/2)	3-3
3-3.	Power Block Diagram (1/2)	3-5
3-4.	Power Block Diagram (2/2)	3-7
4. PRINTED WIRING BOARDS AND SCHEMATIC DIAGRAMS		
4-1.	Frame Schematic Diagrams	4-1
4-2.	Schematic Diagrams	4-5
	CD-434 (CCD IMAGER)	4-7
	SW-386 (1/2) (CONTROL SWITCH)	4-29
	SW-386 (2/2) (LCD DRIVE, TIMING GENERATOR)	4-31
	ST-81 (FLASH DRIVE)	4-33
	MS-130 (MEMORY STICK CONNECTOR)	4-37
	CONTROL SWITCH BLOCK	4-38
4-3.	Printed Wiring Boards	4-39
	CD-434	4-41
	SW-386	4-47
	ST-81	4-49
	MS-130	4-53
4-4.	Waveforms	4-56
4-5.	Mounted Parts Location	4-57
5. REPAIR PARTS LIST		
5-1.	Exploded Views	5-2
5-1-1.	Cabinet Section	5-2
5-1-2.	Lens Section	5-3
5-1-3.	Battery Holder Section	5-4
5-2.	Electrical Parts List	5-5



SECTION 1 SERVICE NOTE

1-1. NOTE FOR REPAIR

Make sure that the flat cable and flexible board are not cracked or bent at the terminal.
Do not insert the cable insufficiently nor crookedly.

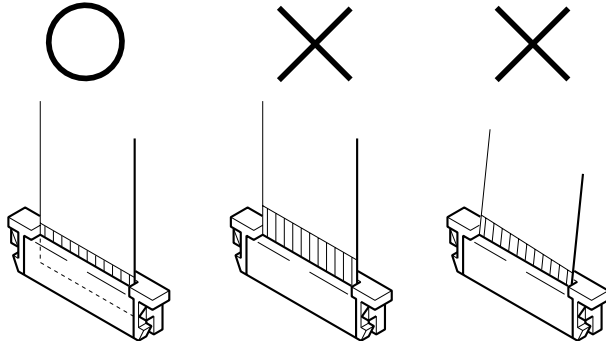

Cut and remove the part of gilt which comes off at the point.
(Be careful or some pieces of gilt may be left inside)

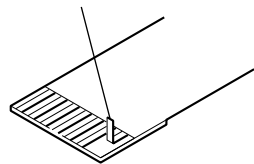

When remove a connector, don't pull at wire of connector.
It is possible that a wire is snapped.

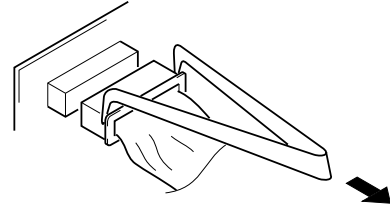

When installing a connector, don't press down at wire of connector.
It is possible that a wire is snapped.

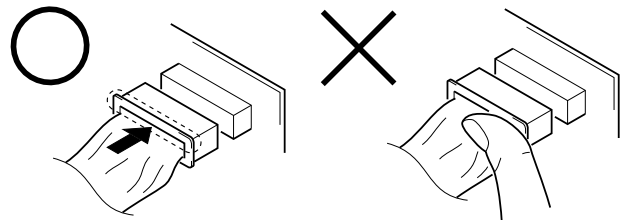

1-2. DISCHARGING OF THE ST-81 FLEXIBLE BOARD'S CHARGING CAPACITOR (C001)

The charging capacitor (C001) of the ST-81 flexible board is charged up to the maximum 300 V potential.

There is a danger of electric shock by this high voltage when the battery is handled by hand. The electric shock is caused by the charged voltage which is kept without discharging when the main power of the unit is simply turned off. Therefore, the remaining voltage must be discharged as described below.

Preparing the Short Jig

To preparing the short jig, a small clip is attached to each end of a resistor of 1 k Ω / 1 W (1-215-869-11).
Wrap insulating tape fully around the leads of the resistor to prevent electrical shock.

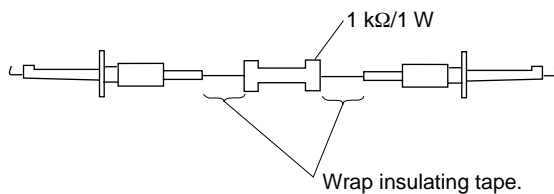

Discharging the Capacitor

Short-circuit between the positive and the negative terminals of charged capacitor with the short jig about 10 seconds.

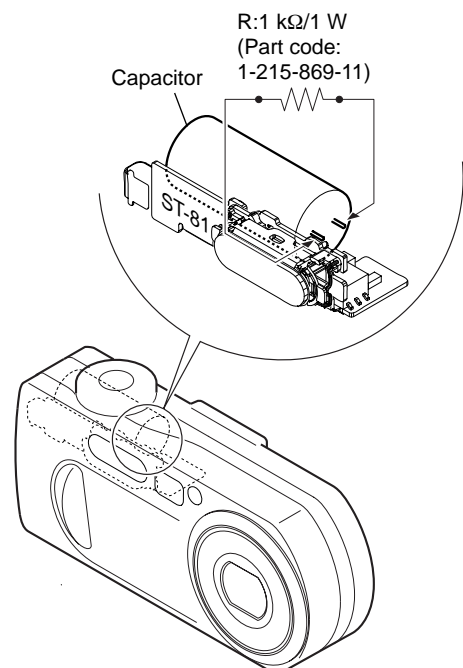

1-3. PRECAUTION ON REPLACING THE VIDEO LENS OR THE SY-83 BOARD

The DSC-P10/P12 uses the position sensor to detect the zoom position.

Accordingly, the zoom position will vary if the position data changes due to the replacement of the video lens or the SY-83 board, thus causing the video lens to collide against the mechanism end when the power is turned off.

Though the position data is calibrated at the “Flange Back Adjustment”, add the following work when making an adjustment at the replacement of video lens to prevent a collision of video lens.

When Replacing the Video Lens

- 1) With current video lens assembled, turn the power on, and set the data of page: 6F, address: 3E to “FF”, then turn the power off.
- 2) Replace the video lens with a new one, turn the power on, and perform the “Flange Back Adjustment”.
Thus, new position data will be written.

When Replacing the SY-83 Board

- 1) Replace the SY-83 board with a new one, set the mode dial to “PLAY”, turn the power on, and set the data of page: 6F, address: 3E to “FF”, then turn the power off.
- 2) Set the mode dial to “CAMERA”, turn the power on, and perform the “Flange Back Adjustment”.
Thus, new position data will be written.

1-4. NOTE IN LENS FRAME INSTALLATION

When tightening a screw, have both sides of the lens block assembly so as not for the load to depend.

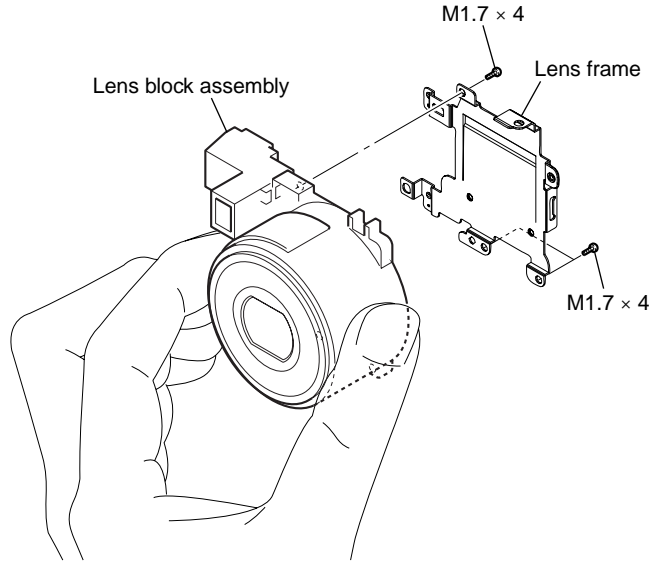

1-5. DESCRIPTION ON SELF-DIAGNOSIS DISPLAY

Self-diagnosis display

The camera has a self-diagnosis display. This function displays the camera condition with five-digits (a combination of a letter and figures) on the LCD screen. If this occurs check the following code chart. The five-digits display informs you of the camera's current condition. The last two digits (indicated by □□) will differ depending on the state of the camera.

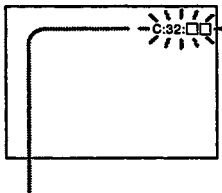

Self-diagnosis display

- C: □□: □□

You can reverse the camera malfunction yourself. (However, contact your Sony dealer or local authorized Sony service facility when you cannot recover from the camera malfunction.)

- E: □□: □□

Contact your Sony dealer or local authorized Sony service facility.

Display Code	Countermeasure	Cause	Caution Display During Error
C:32:□□	Turn the power off and on again.	Trouble with hardware.	SYSTEM ERROR
C:13:□□	Format the "Memory stick".	Unformatted memory stick is inserted.	FORMAT ERROR
	Insert a new "Memory Stick".	Memory stick is broken.	MEMORY STICK ERROR
E:61:□□	Checking of lens drive circuit.	When failed in the focus and zoom initialization.	—
E:91:□□	Checking of flash unit or replacement of flash unit.	Abnormality when flash is being charged.	

[SERVICE POSITION]

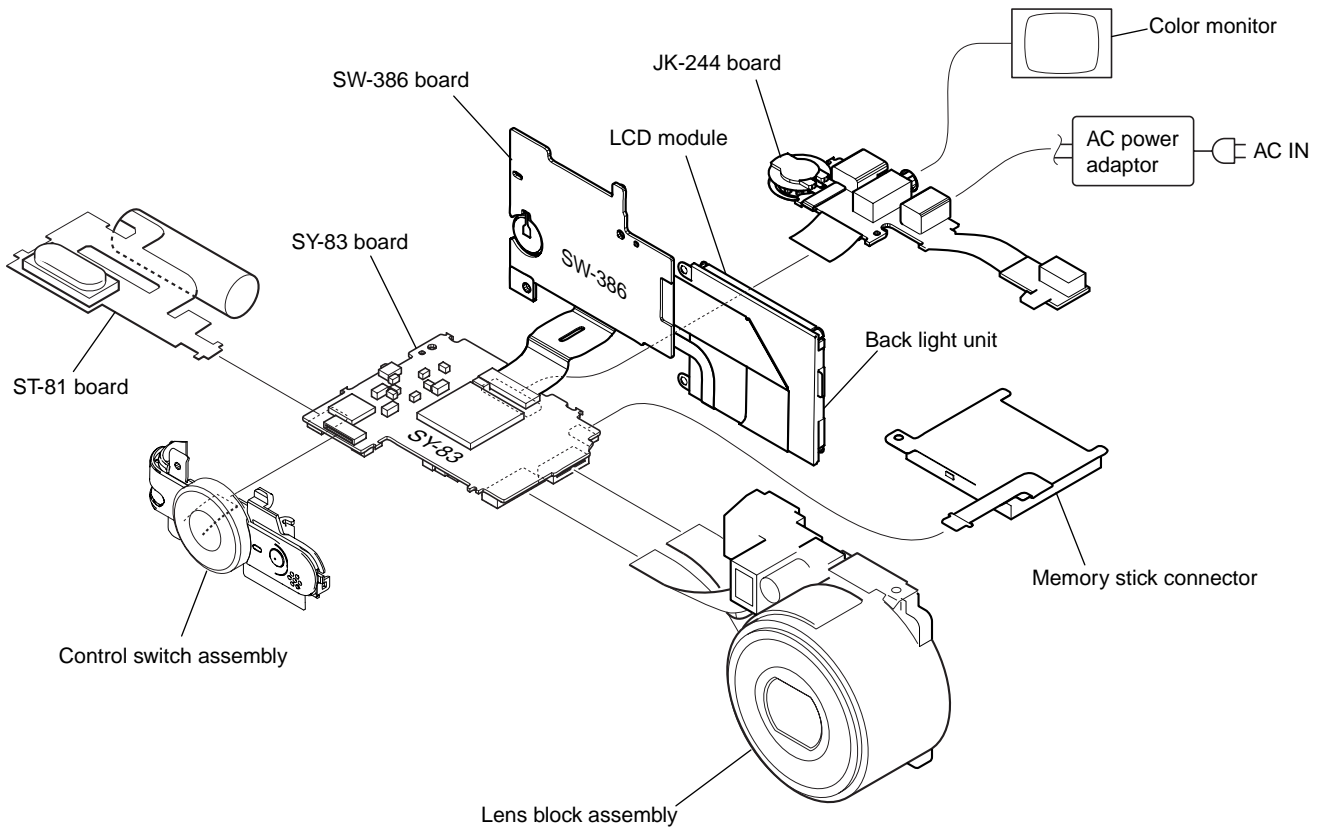

The procedure for a service position

- ① 2-2. CABINET (REAR) ASSEMBLY (PAGE 2-3)
- ② 2-3. LCD MODULE (PAGE 2-4)
- ③ 2-4. CABINET FRONT ASSEMBLY (PAGE 2-4)
- ④ 2-5. CONTROL SWITCH BLOCK (PAGE 2-5)
- ⑤ 2-6. CABINET (LOWER) ASSEMBLY (PAGE 2-6)
- ⑥ 2-7. LENS BLOCK ASSEMBLY (PAGE 2-6)
- ⑦ 2-8. ST-81 BOARD (PAGE 2-7)
- ⑧ 2-9. SY-83 BOARD (PAGE 2-7)
- ⑨ 2-10. MS-130 BOARD (PAGE 2-8)
- ⑩ 2-11. SW-386 BOARD (PAGE 2-8)
- ⑪ 2-12. JK-244 BOARD (PAGE 2-9)

Note: Follow the disassembly procedure in the numerical order given.

2-1. BATTERY LID

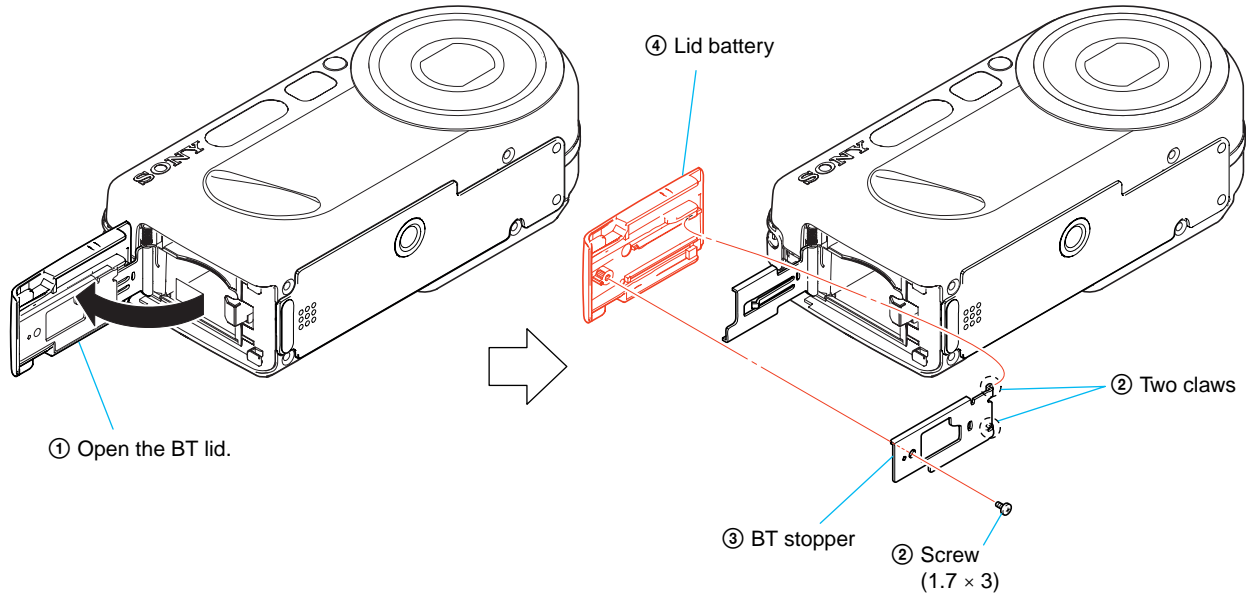

2-2. CABINET (REAR) ASSEMBLY

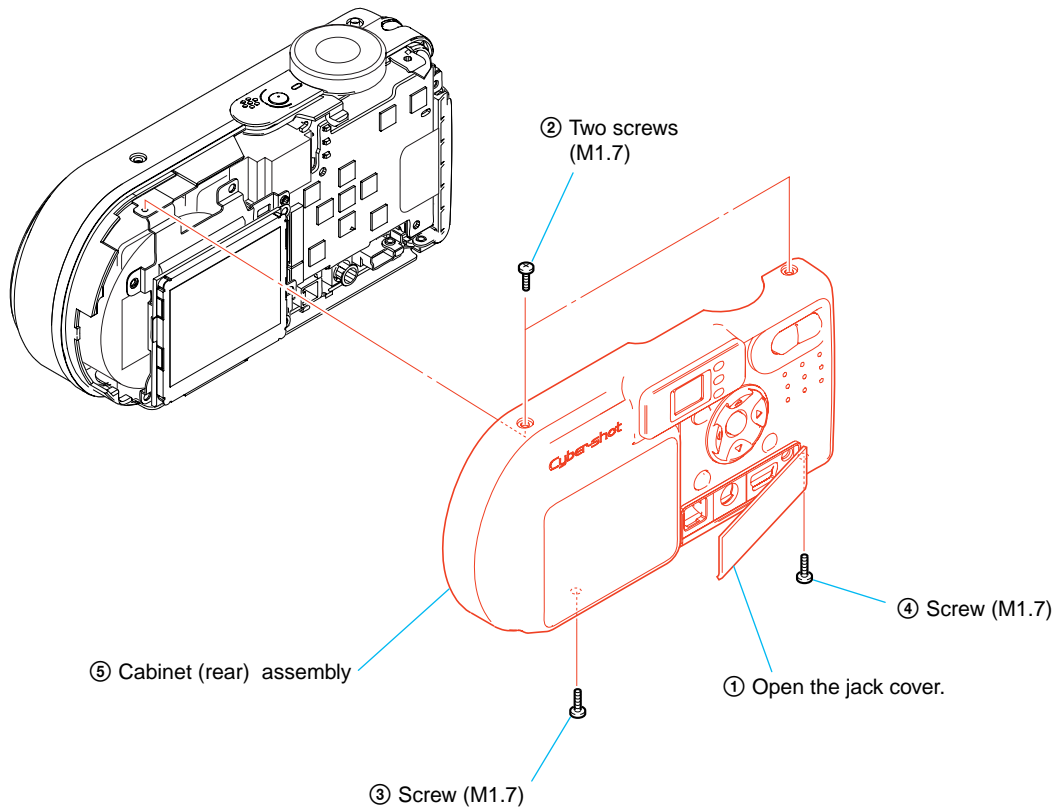

2-3. LCD MODULE

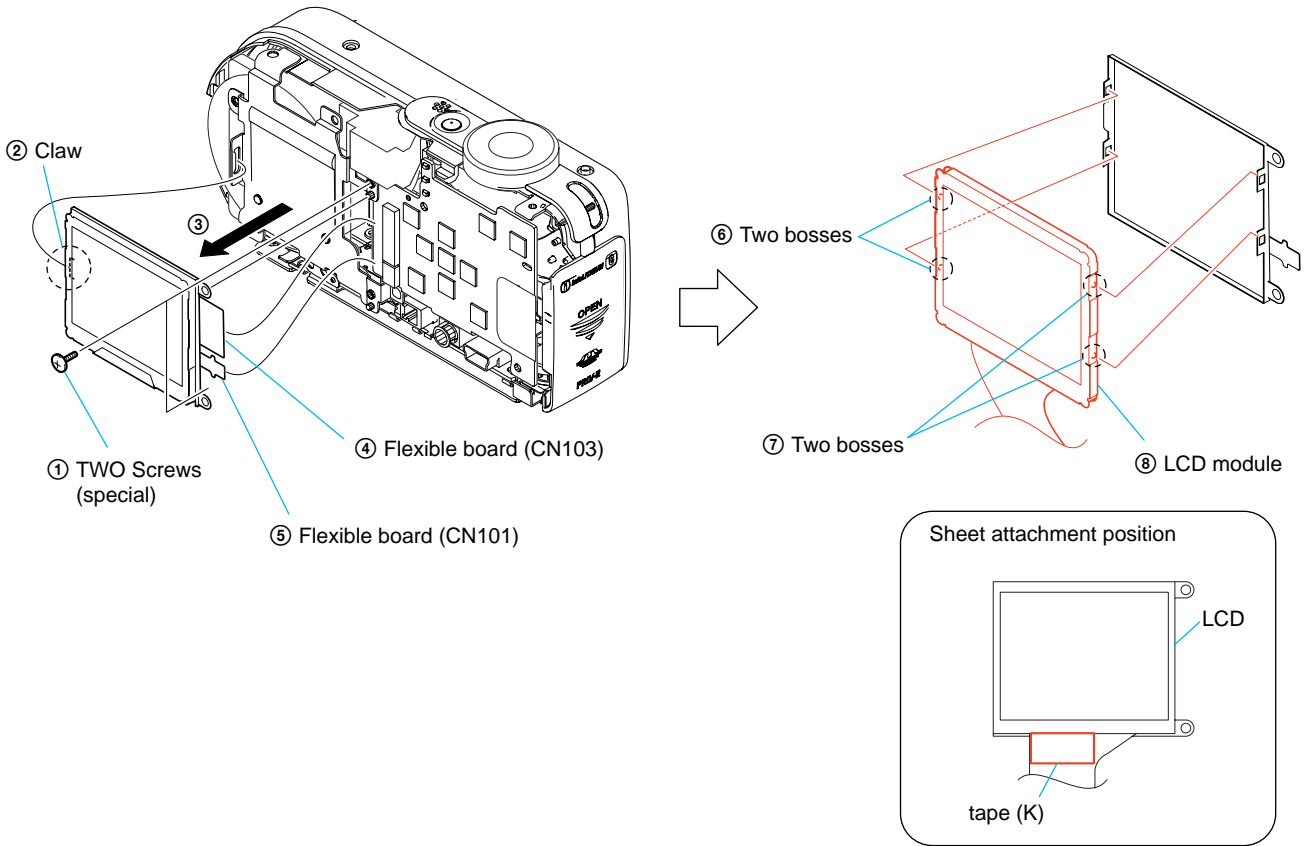

2-4. CABINET FRONT ASSEMBLY

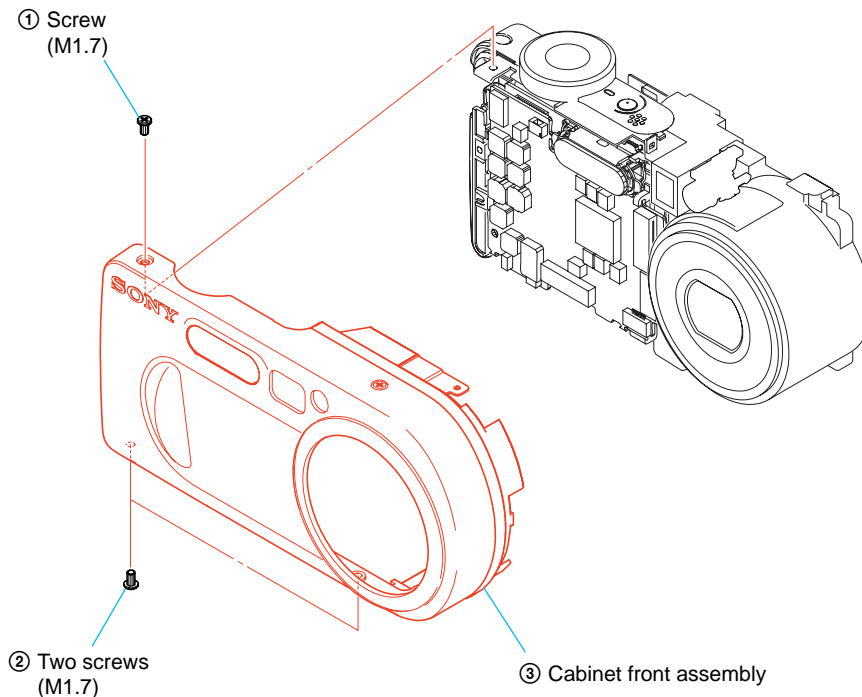

2-5. CONTROL SWITCH BLOCK

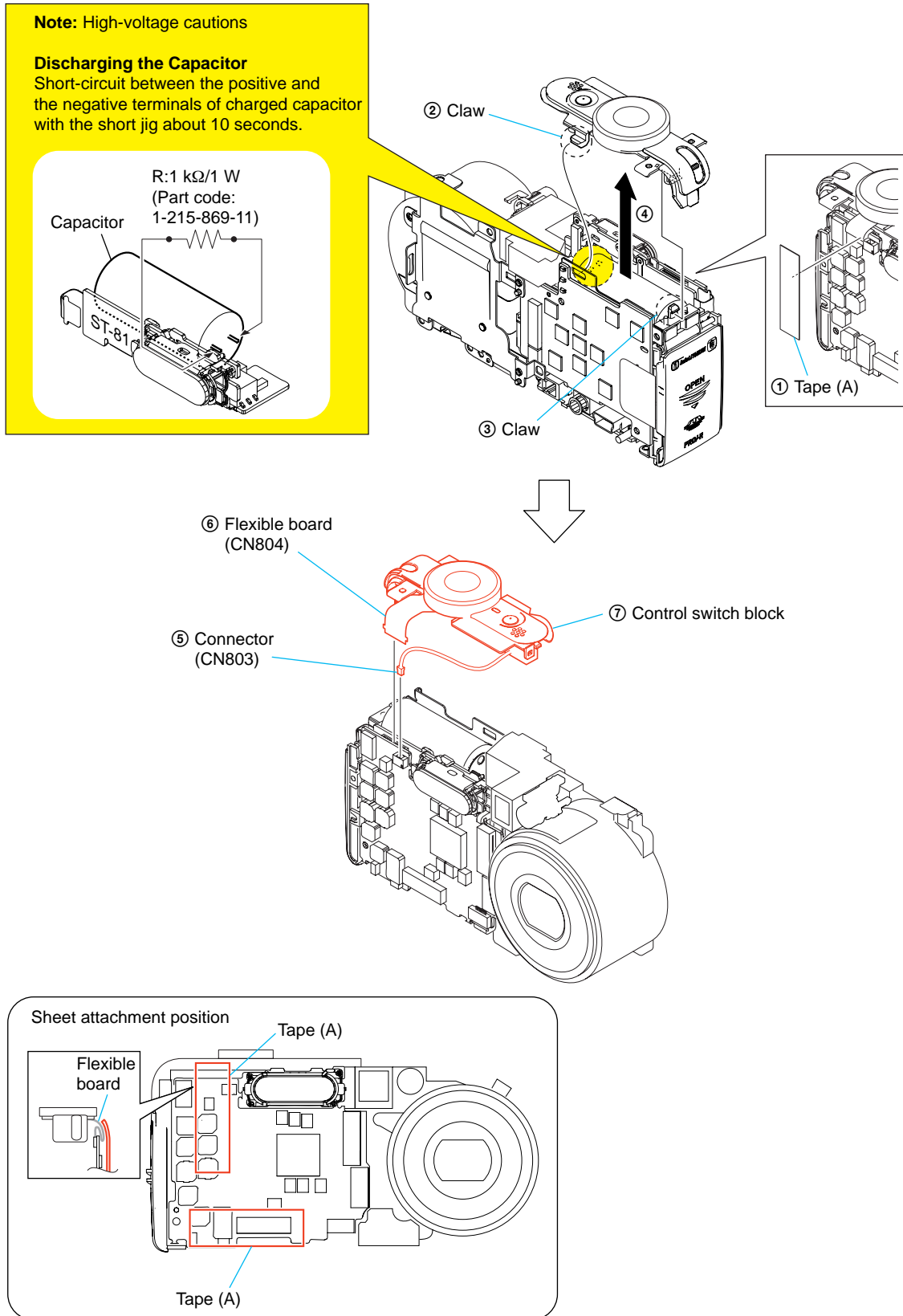

2-6. CABINET (LOWER) ASSEMBLY

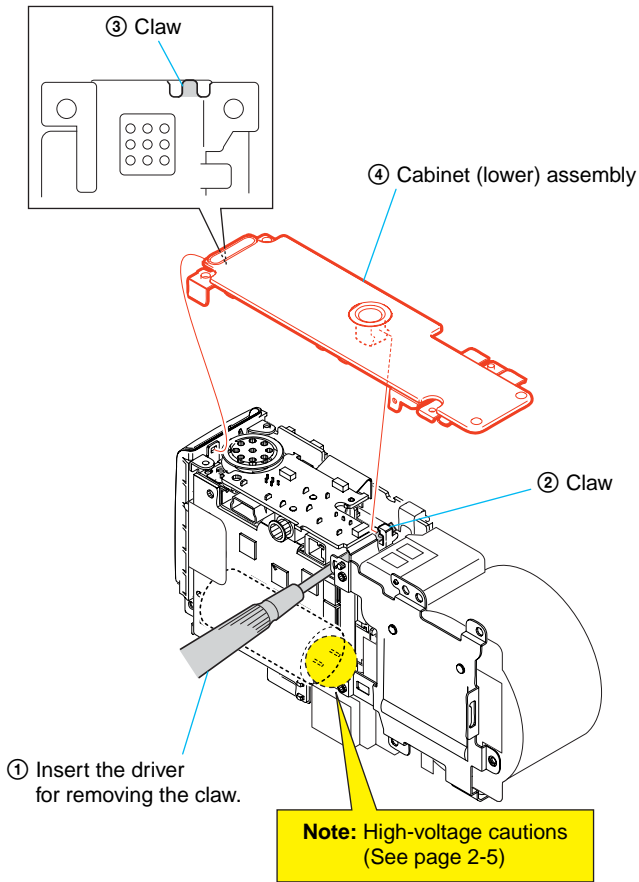

Note: To disengage the claw, pass a flat headed driver under the flexible cable. It may be a cause of breakage of the flexible cable to pass a flat headed driver above the flexible cable.

2-7. LENS BLOCK ASSEMBLY

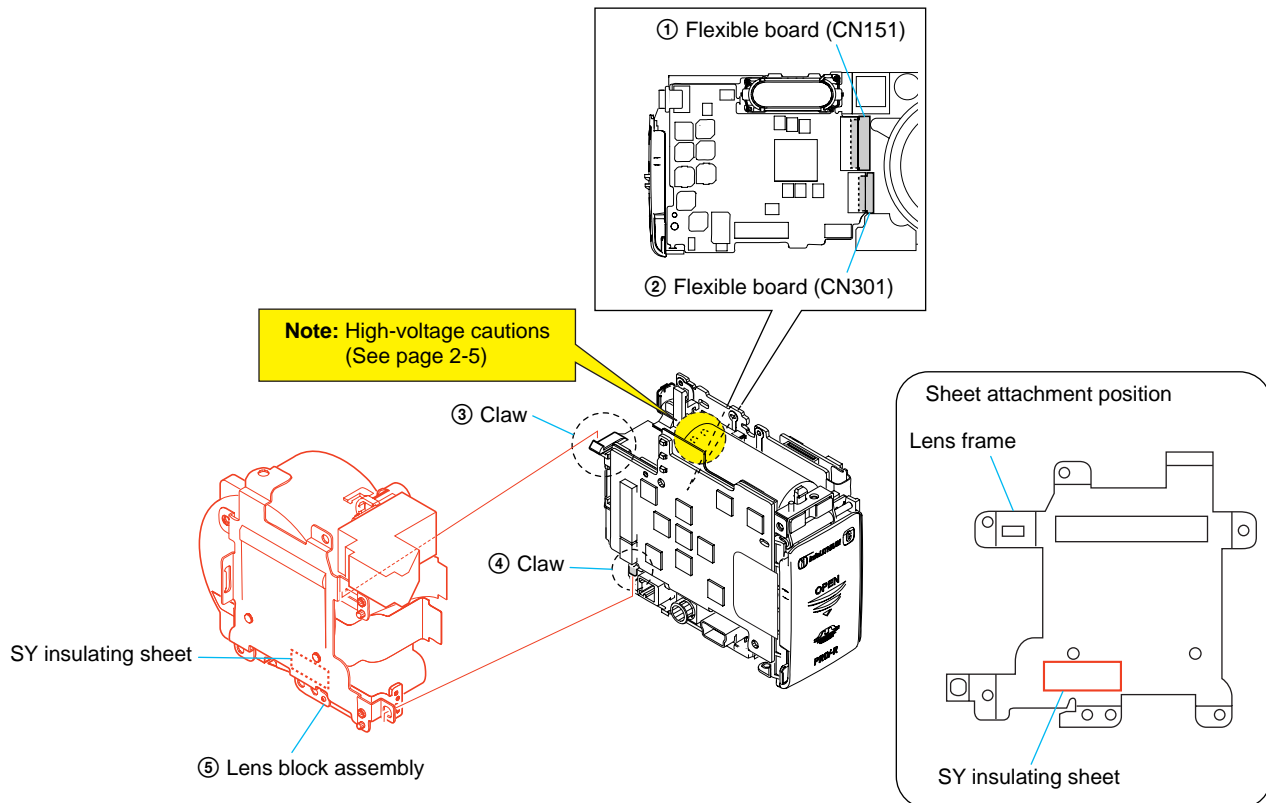

2-8. ST-81 BOARD

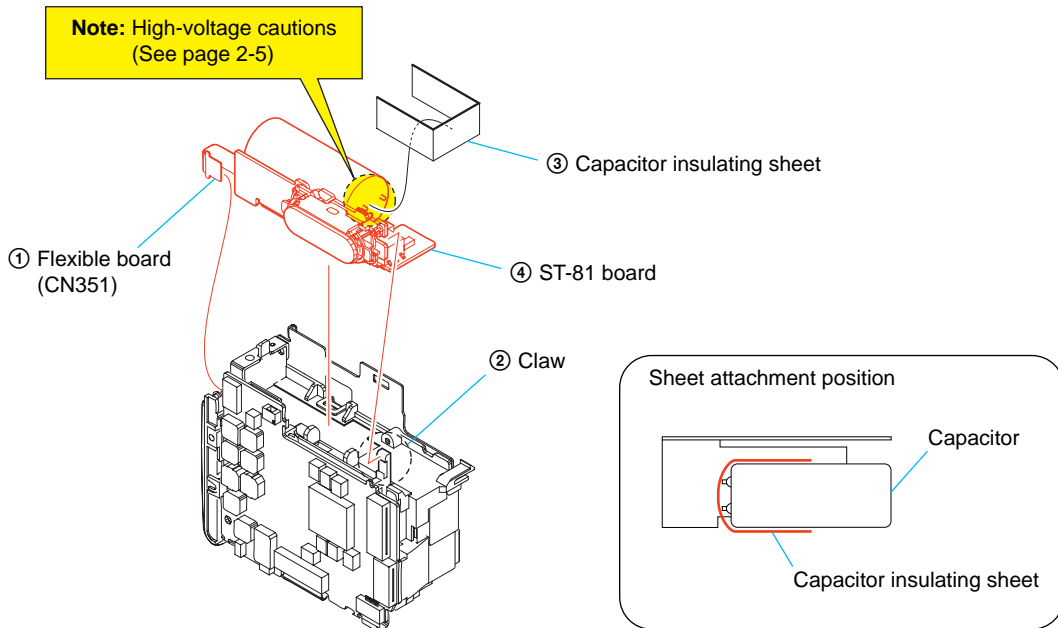

2-9. SY-83 BOARD

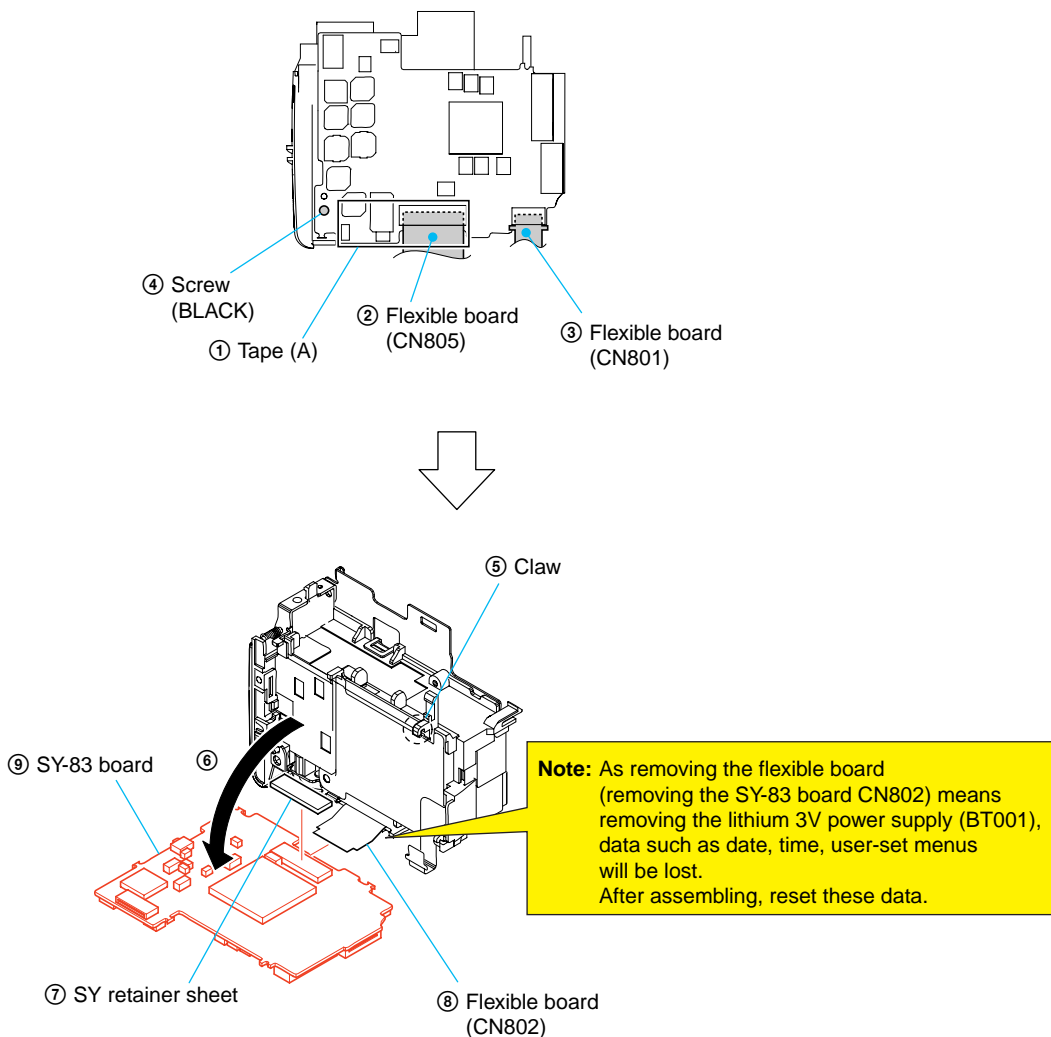

2-10.MS-130 BOARD

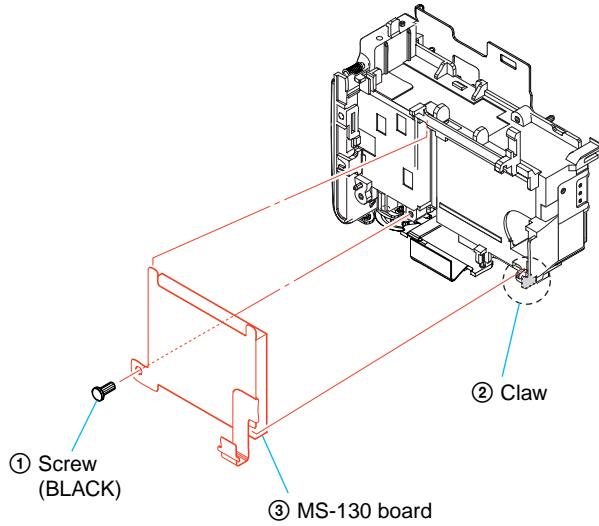

2-11.SW-386 BOARD

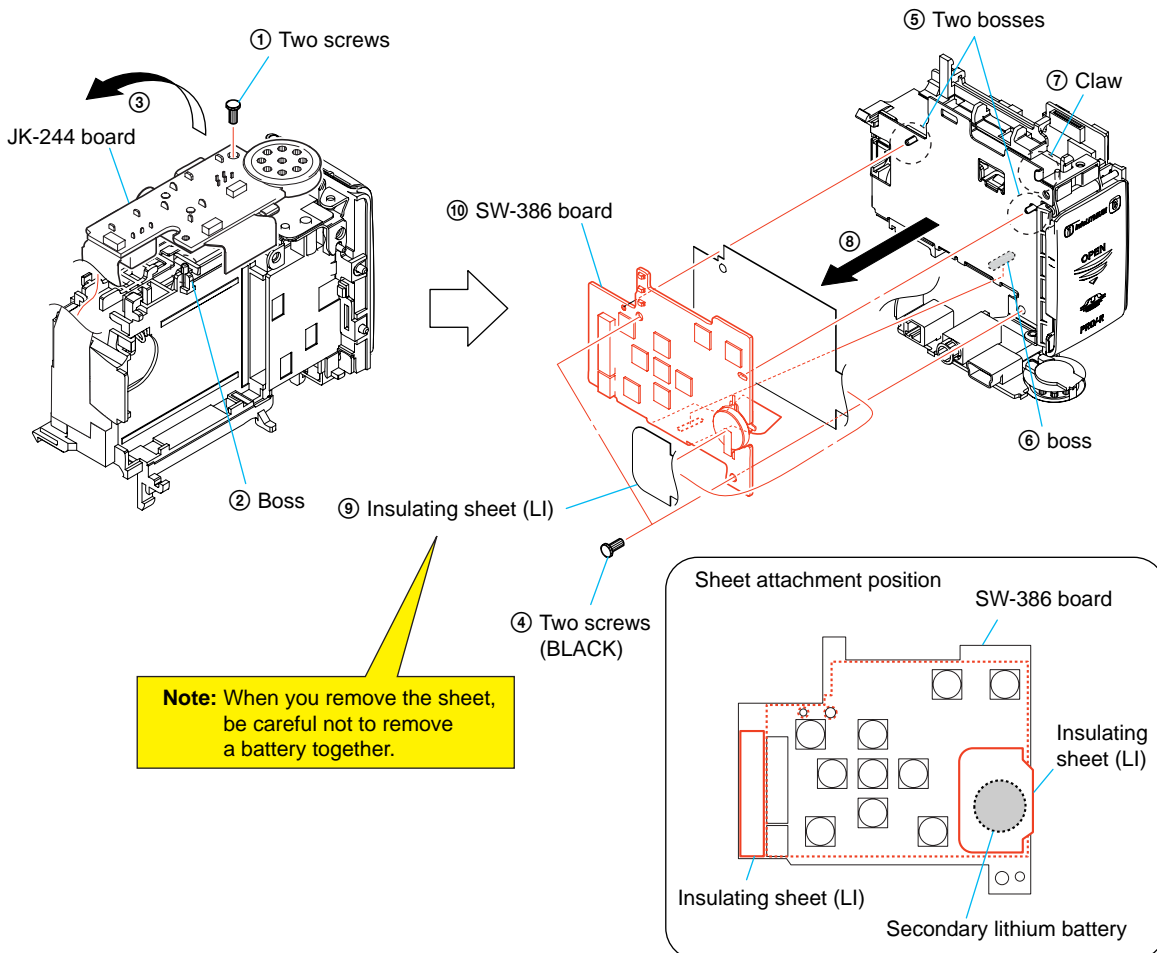

2-12. JK-244 BOARD

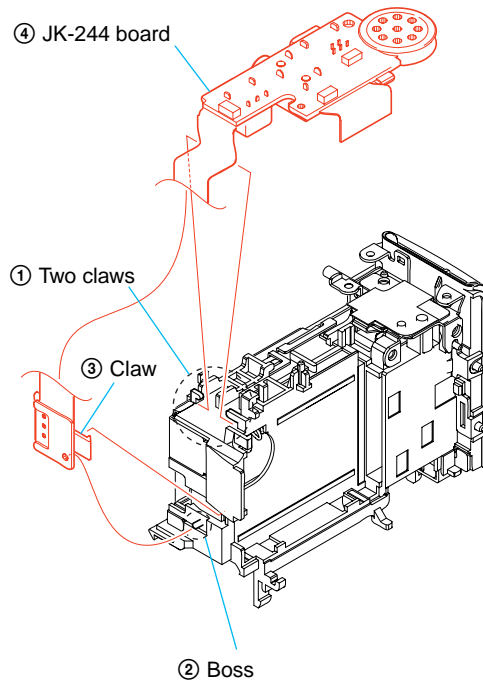

2-13. CD-434 BOARD

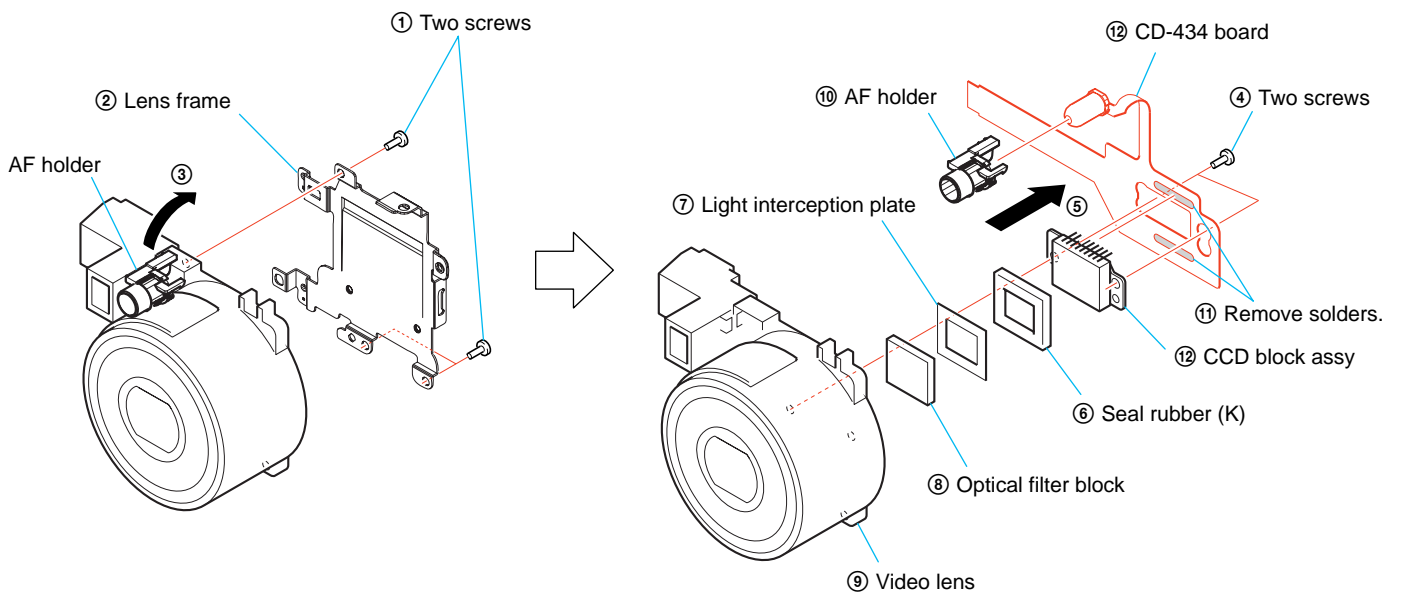



2-14.CIRCUIT BOARDS LOCATION

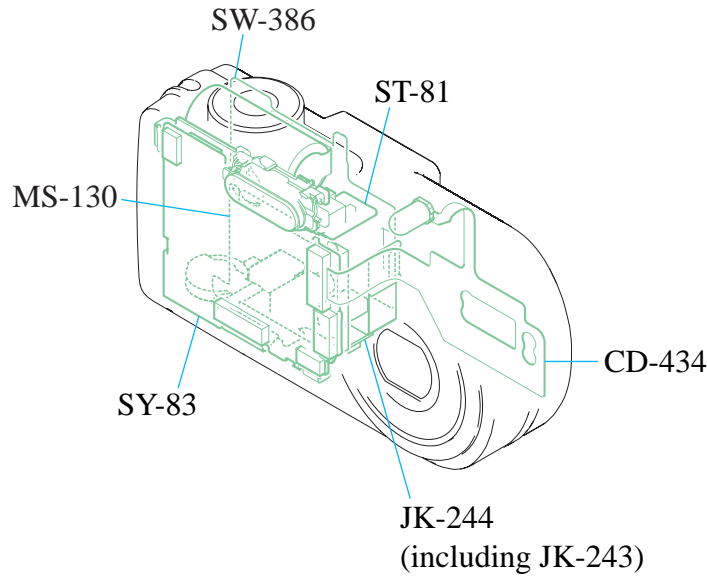

Board Name	Function
CD-434	CCD IMAGER
JK-244 (including JK-243)	JACK
MS-130	MEMORY STICK CONNECTOR
ST-81	FLASH DRIVE
SW-386	CONTROL SWITCH, LCD DRIVE, TIMING GENERATOR
SY-83	CAMERA MODULE, CAMERA DSP, 256M SDRAM, VIDEO AMP, LENS DRIVE, SH DSP, 16M FLASH, MEMORY, CLOCK GENERATOR, FRONT CONTROL, AUDIO, FLASH CONTROL, DC/DC CONVERTER



HELP

Sheet attachment positions and procedures of processing the flexible boards/harnesses are shown.

MAIN BLOCK SECTION

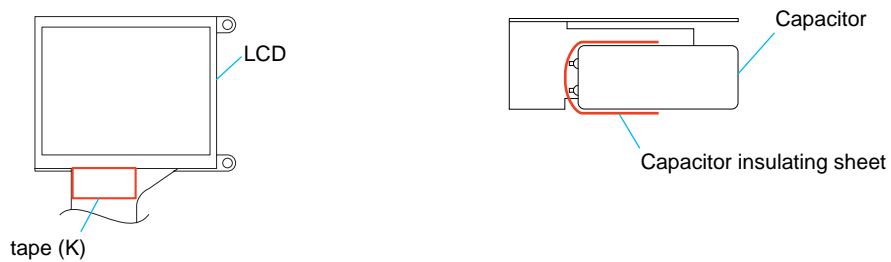
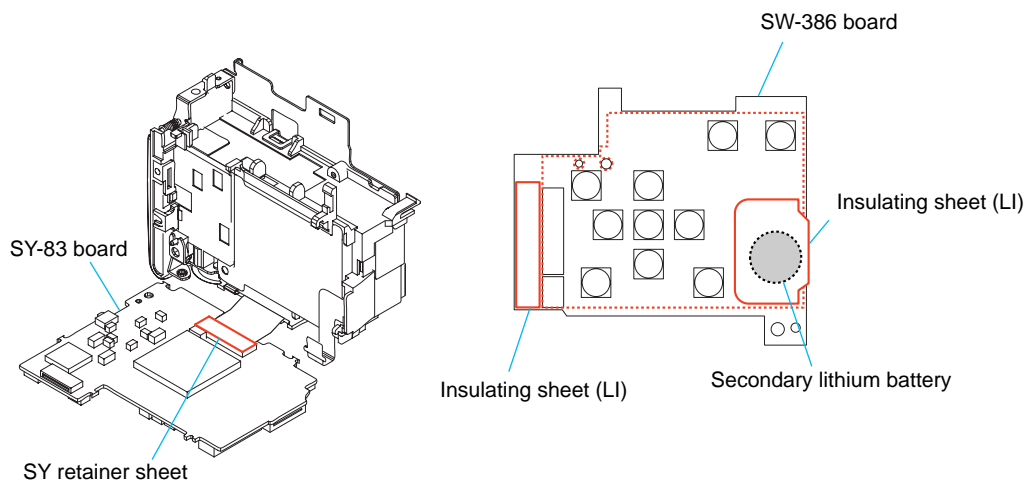
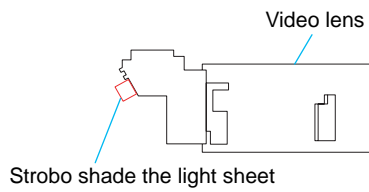
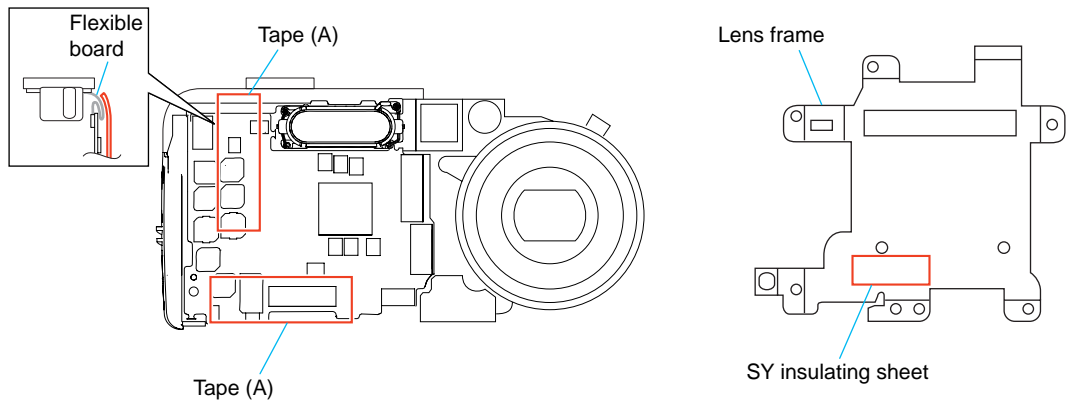



3. BLOCK DIAGRAMS

Link

• [OVERALL BLOCK DIAGRAM \(1/2\)](#)

• [POWER BLOCK DIAGRAM \(1/2\)](#)

• [OVERALL BLOCK DIAGRAM \(2/2\)](#)

• [POWER BLOCK DIAGRAM \(2/2\)](#)



SECTION 3 BLOCK DIAGRAMS

3. BLOCK DIAGRAMS

3-1. OVERALL BLOCK DIAGRAM (1/2) () : Number in parenthesis () indicates the division number of schematic diagram where the component is located.

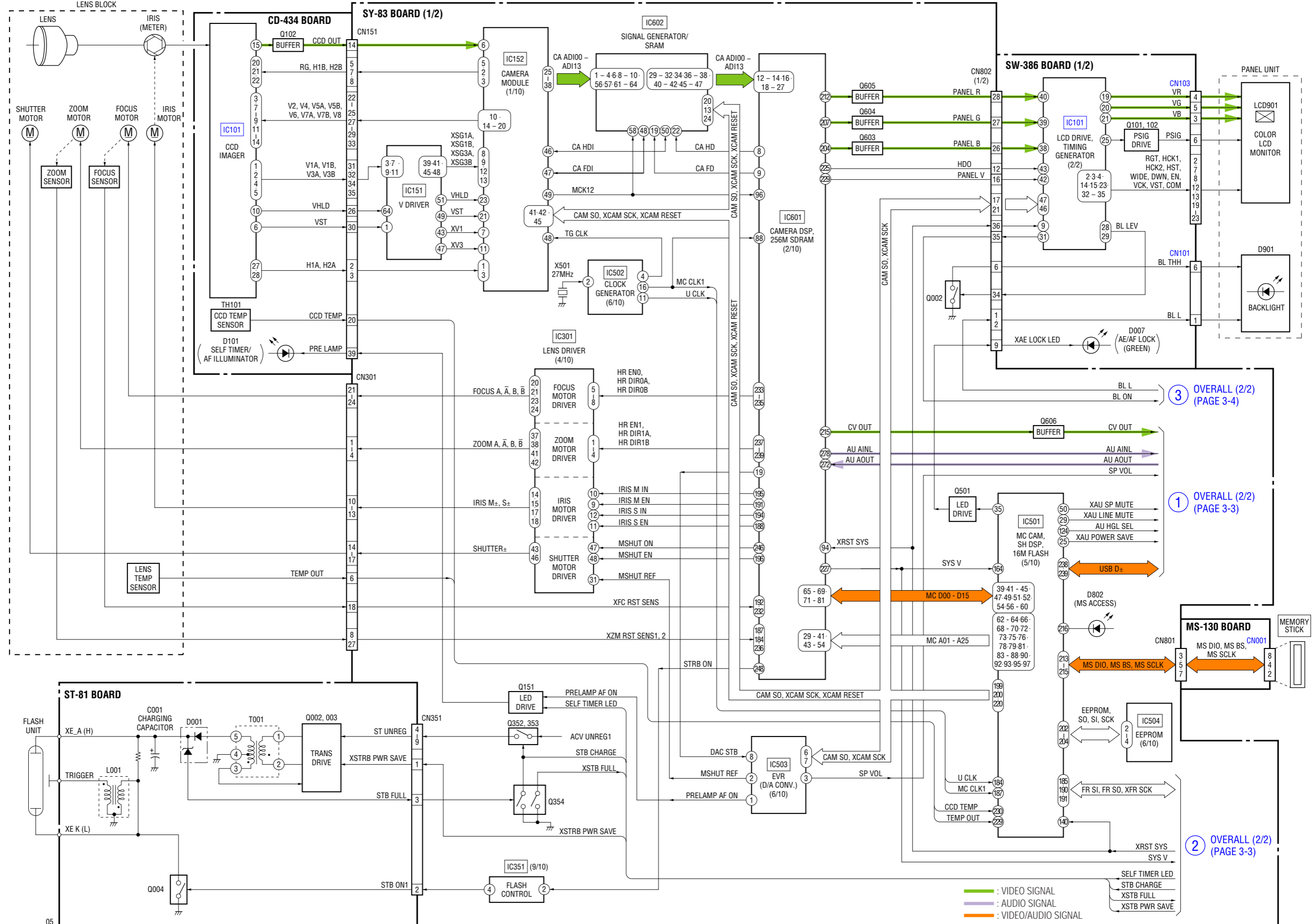

③ OVERALL (2/2)
(PAGE 3-4)

① OVERALL (2/2)
(PAGE 3-3)

② OVERALL (2/2)
(PAGE 3-3)



3. BLOCK DIAGRAMS

3-2. OVERALL BLOCK DIAGRAM (2/2) () : Number in parenthesis () indicates the division number of schematic diagram where the component is located.

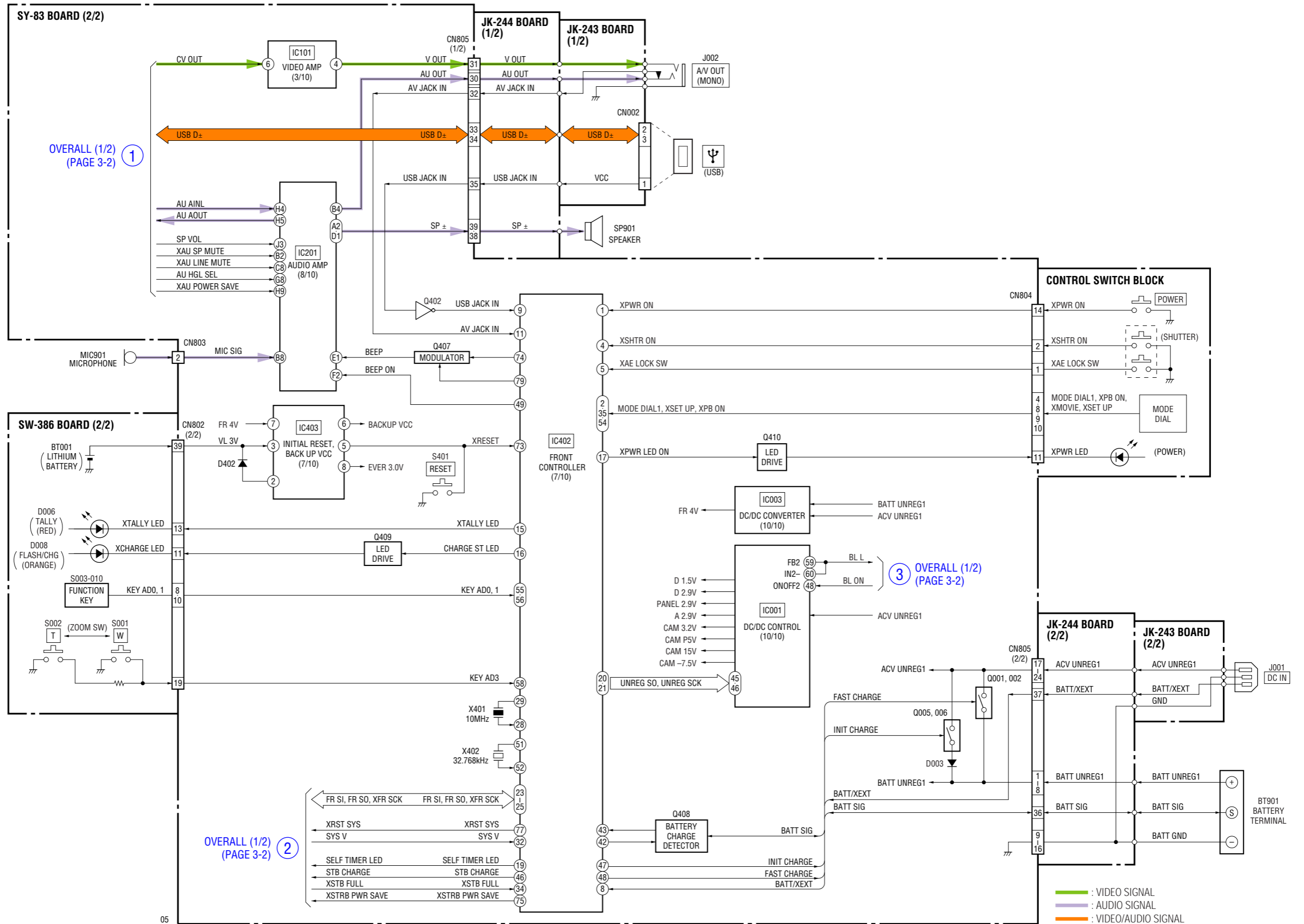



3. BLOCK DIAGRAMS

3-3. POWER BLOCK DIAGRAM (1/2) () : Number in parenthesis () indicates the division number of schematic diagram where the component is located.

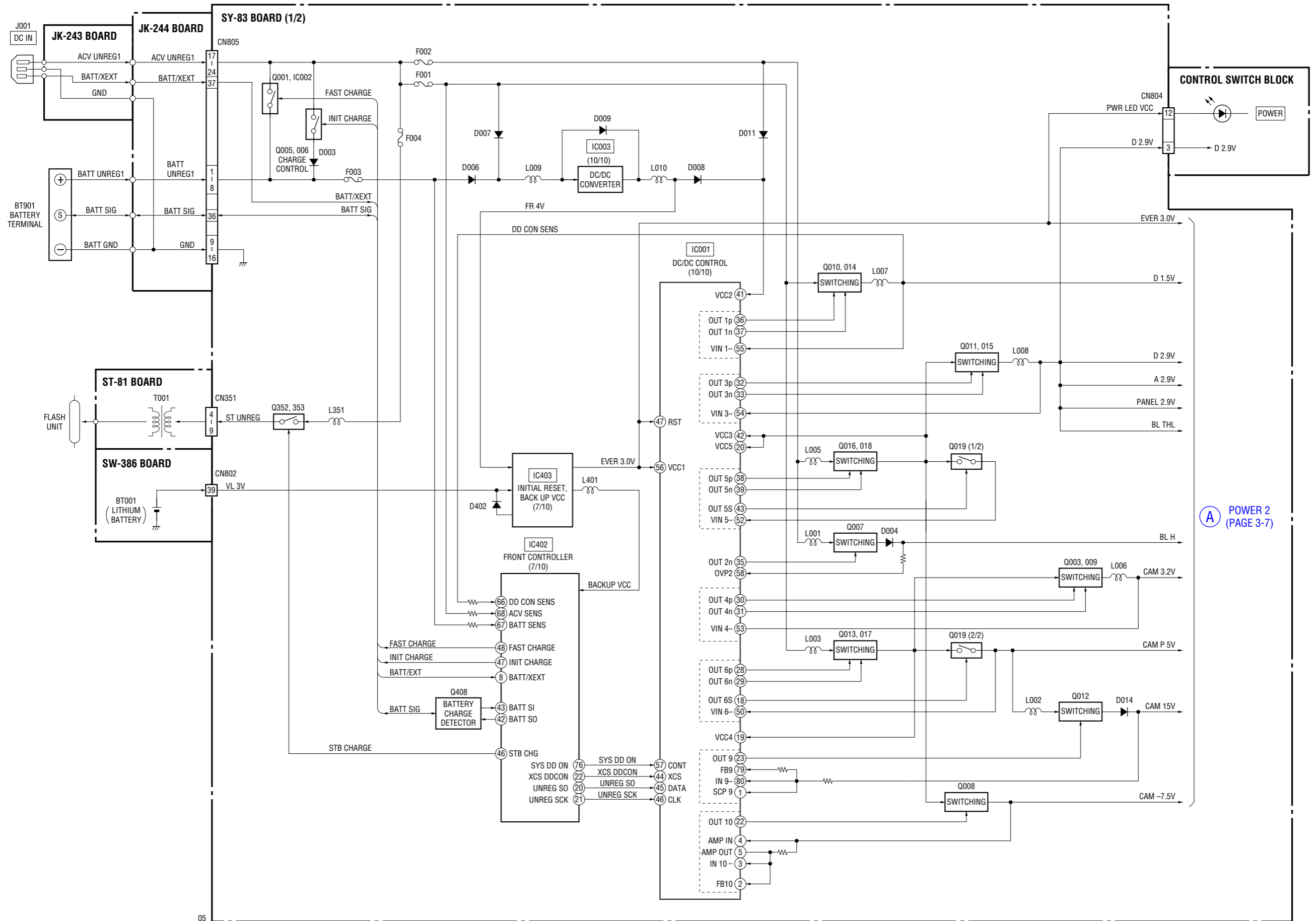

(A) POWER 2 (PAGE 3-7)



3. BLOCK DIAGRAMS

3-4. POWER BLOCK DIAGRAM (2/2) () : Number in parenthesis () indicates the division number of schematic diagram where the component is located.

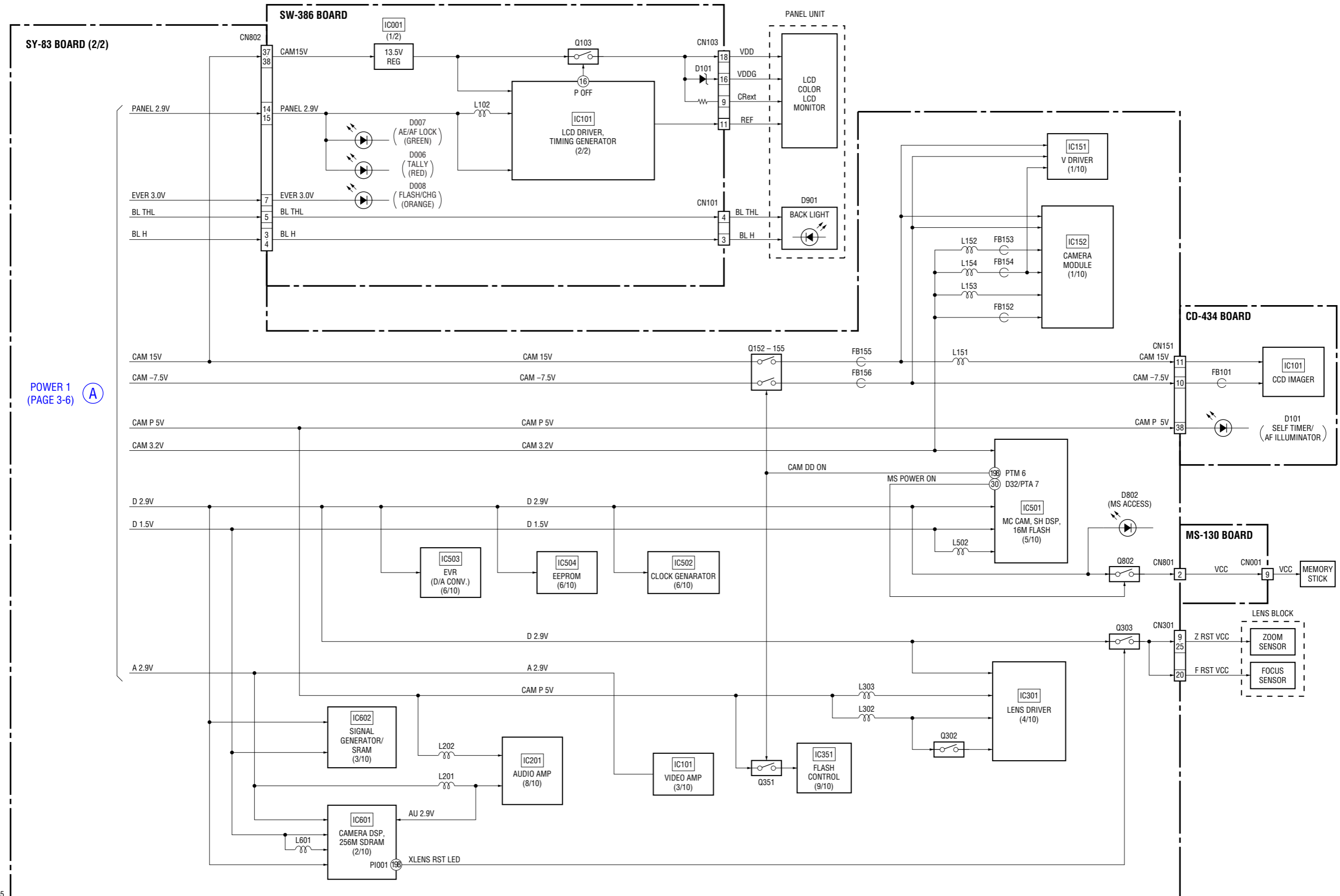

POWER 1 (PAGE 3-6) A



4-2. SCHEMATIC DIAGRAMS

4-2. SCHEMATIC DIAGRAMS

THIS NOTE IS COMMON FOR SCHEMATIC DIAGRAMS
 (In addition to this, the necessary note is printed in each block)

(For schematic diagrams)

- All capacitors are in μF unless otherwise noted. pF : μ μF . 50V or less are not indicated except for electrolytics and tantalums.
- Chip resistors are 1/10 W unless otherwise noted. $\text{k}\Omega=1000 \Omega$, $\text{M}\Omega=1000 \text{k}\Omega$.
- Caution when replacing chip parts. New parts must be attached after removal of chip. Be careful not to heat the minus side of tantalum capacitor, Because it is damaged by the heat.
- Some chip part will be indicated as follows.

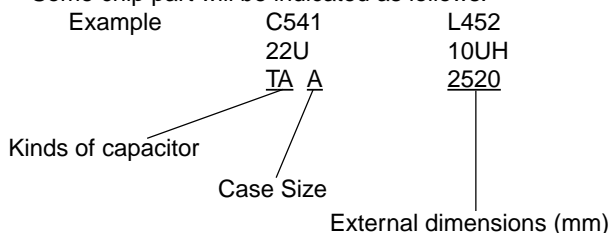

- Constants of resistors, capacitors, ICs and etc with XX indicate that they are not used. In such cases, the unused circuits may be indicated.
- Parts with ★ differ according to the model/destination. Refer to the mount table for each function.
- All variable and adjustable resistors have characteristic curve B, unless otherwise noted.
- Signal name
 XEDIT → EDIT PB/XREC → PB/REC
- : non flammable resistor
- : fusible resistor
- : panel designation
- : B+ Line
- : B- Line
- : IN/OUT direction of (+,-) B LINE.
- : adjustment for repair.
- : VIDEO SIGNAL (ANALOG)
- : AUDIO SIGNAL (ANALOG)
- : VIDEO/AUDIO SIGNAL
- : VIDEO/AUDIO/SERVO SIGNAL
- : SERVO SIGNAL

(Measuring conditions voltage and waveform)

- Voltages and waveforms are measured between the measurement points and ground when camera shoots color bar chart of pattern box. They are reference values and reference waveforms. (VOM of DC 10 M Ω input impedance is used)
- Voltage values change depending upon input impedance of VOM used.)

Note : The components identified by mark Δ or dotted line with mark Δ are critical for safety. Replace only with part number specified.

1. Connection

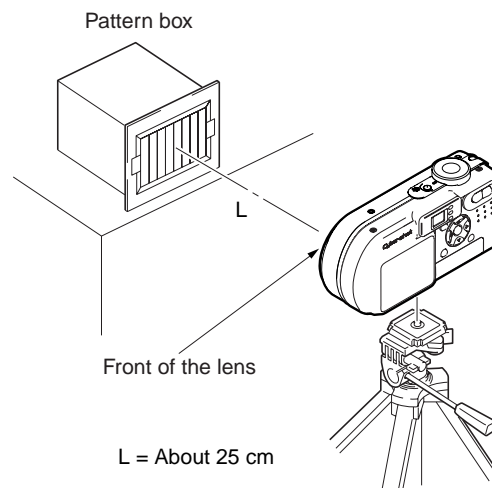

2. Adjust the distance so that the output waveform of Fig. a and the Fig. b can be obtain.

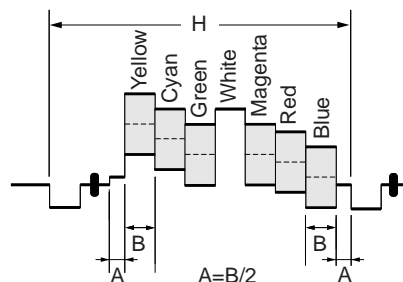

Fig. a (Video output terminal output waveform)

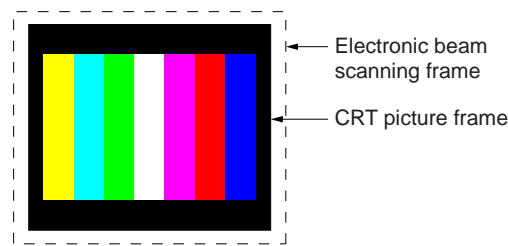

Fig.b (Picture on monitor TV)

When indicating parts by reference number, please include the board name.

Note : Les composants identifiés par une marque Δ sont critiques pour la sécurité. Ne les remplacer que par une pièce portant le numéro spécifiée.



4-2. SCHEMATIC DIAGRAMS

Link

• CD-434 BOARD (CCD IMAGER)

• ST-81 BOARD (FLASH DRIVE)

• SW-386 BOARD (1/2) (CONTROL SWITCH)

• MS-130 BOARD
(MEMORY STICK CONNECTOR)

• SW-386 BOARD (2/2)
(LCD DRIVE, TIMING GENERATOR)

• CONTROL SWITCH BLOCK

• COMMON NOTE FOR SCHEMATIC DIAGRAMS

• WAVEFORMS



For Schematic Diagram

• Refer to page 4-41 for printed wiring board.

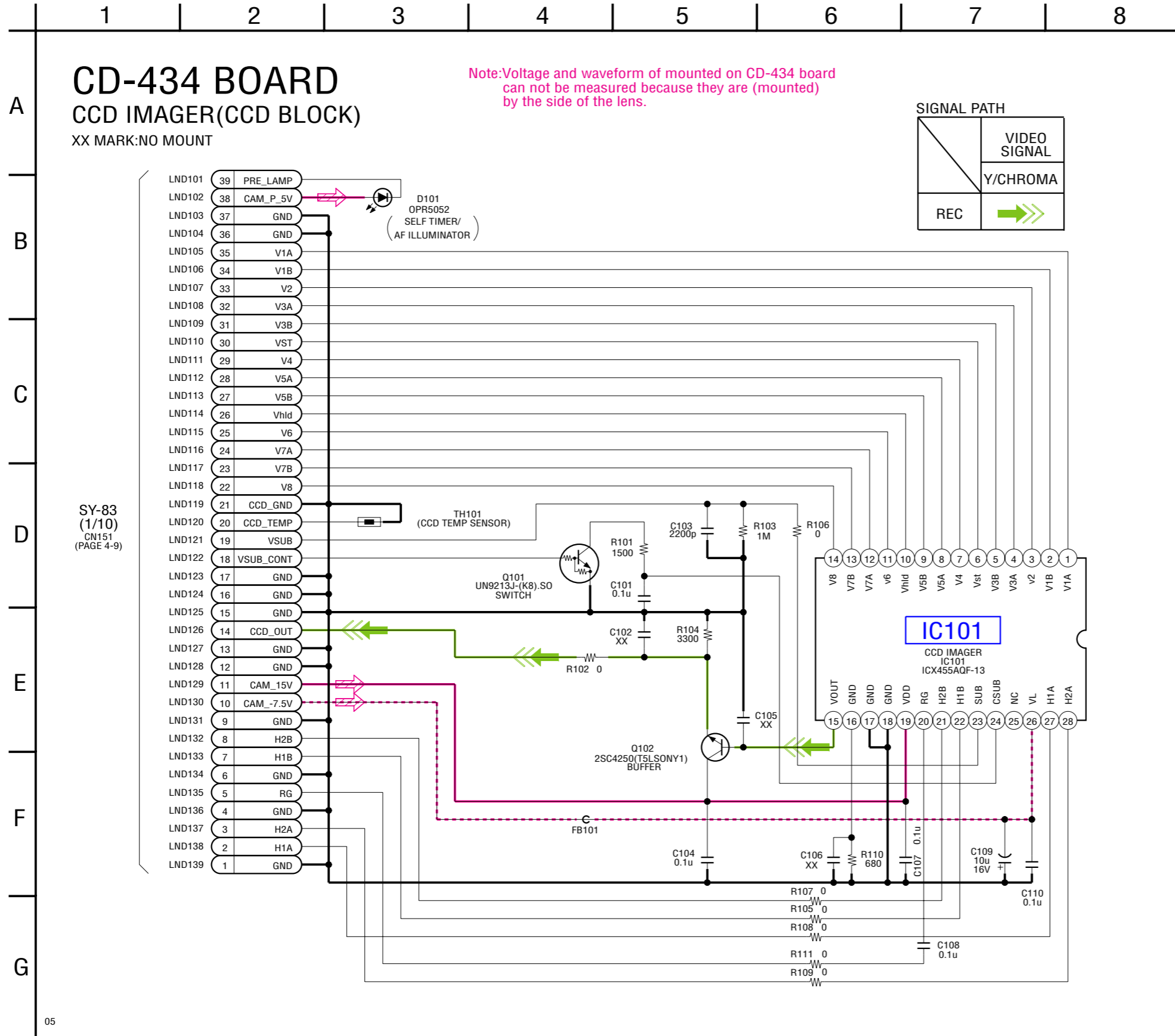

Precautions for Replacement of CCD Imager

- The CD-434 board mounted as a repair part is not equipped with a CCD imager. When replacing this board, remove the CCD imager from the old one and mount it onto the new one.
- If the CCD imager has been replaced, carry out all the adjustments for the camera section.
- As the CCD imager may be damaged by static electricity from its structure, handle it carefully like for the MOS IC. In addition, ensure that the receiver is not covered with dusts nor exposed to strong light.

Schematic diagram of the SY-83 board are not shown.
Pages from 4-9 to 4-28 are not shown.



For Schematic Diagram

• Refer to page 4-47 for printed wiring board.

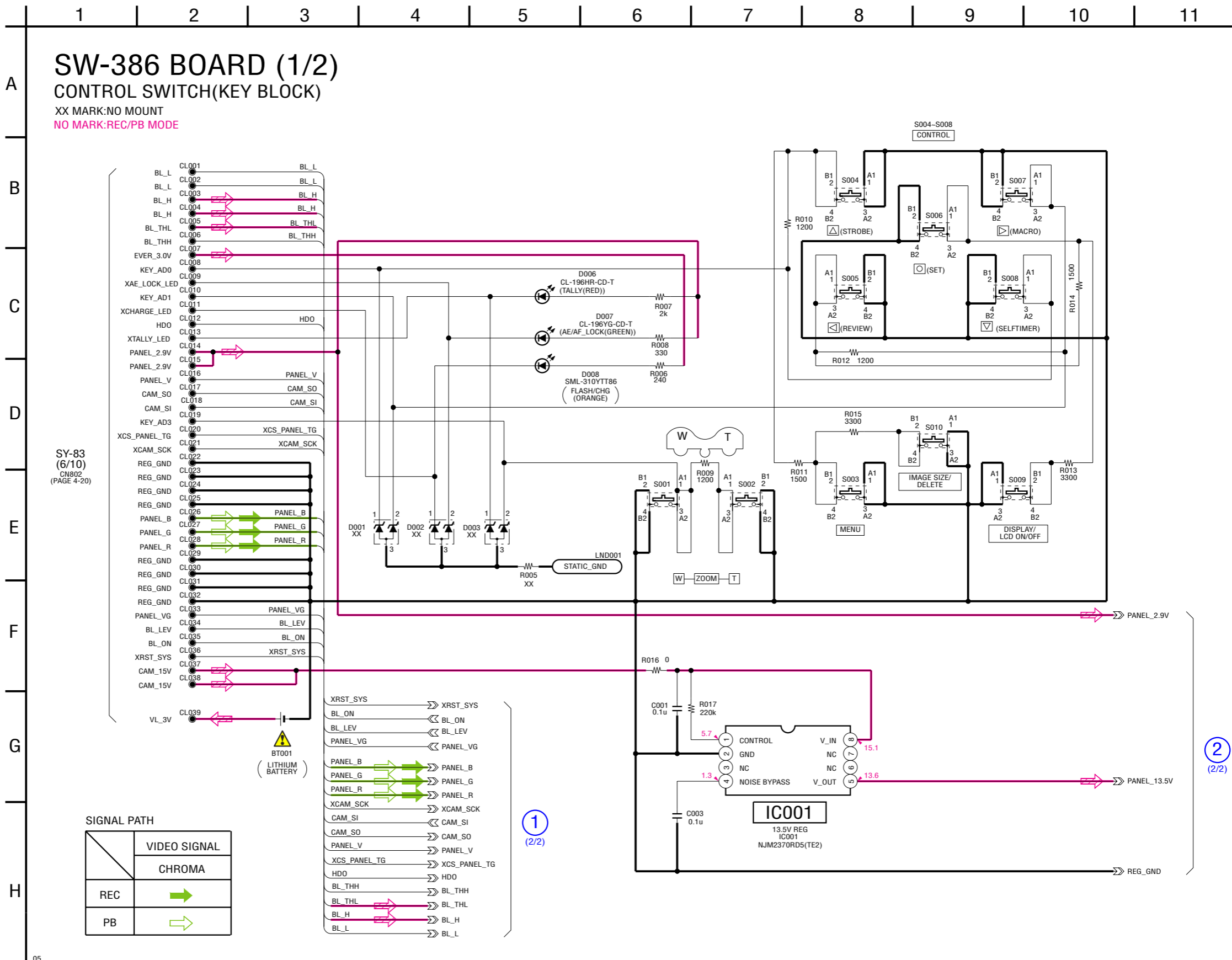

The components identified by mark \triangle or dotted line with mark \triangle are critical for safety. Replace only with part number specified.

Les composants identifiés par une marque \triangle sont critiques pour la sécurité. Ne les remplacer que par une pièce portant le numéro spécifié.



4-2. SCHEMATIC DIAGRAMS

SW-386 PRINTED WIRING BOARD

For Schematic Diagram

- Refer to page 4-47 for printed wiring board.
- Refer to page 4-56 for waveforms.

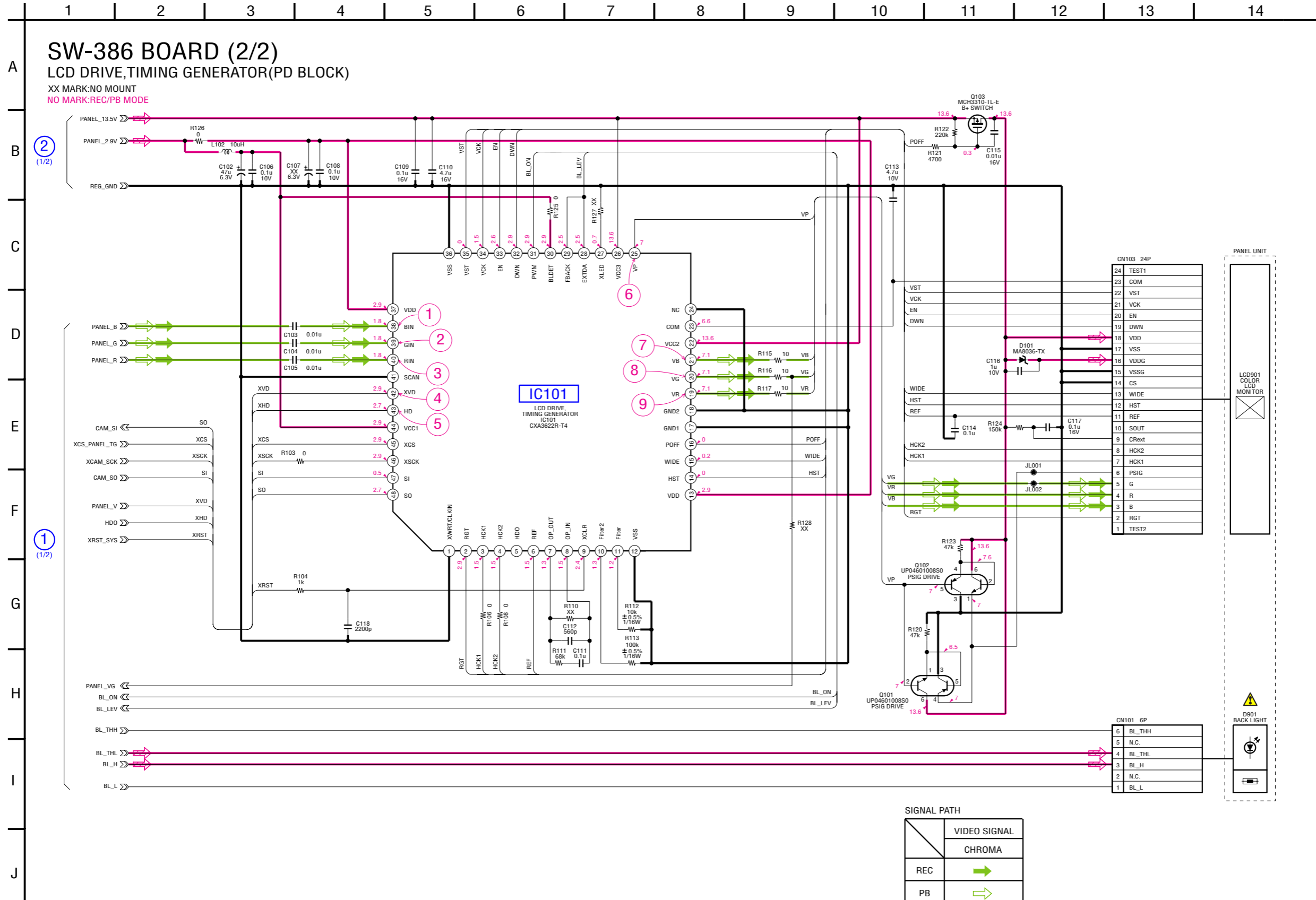

The components identified by mark Δ or dotted line with mark Δ are critical for safety. Replace only with part number specified.

Les composants identifiés par une marque Δ sont critiques pour la sécurité. Ne les remplacer que par une pièce portant le numéro spécifié.



For Schematic Diagram
 • Refer to page 4-49 for printed wiring board.

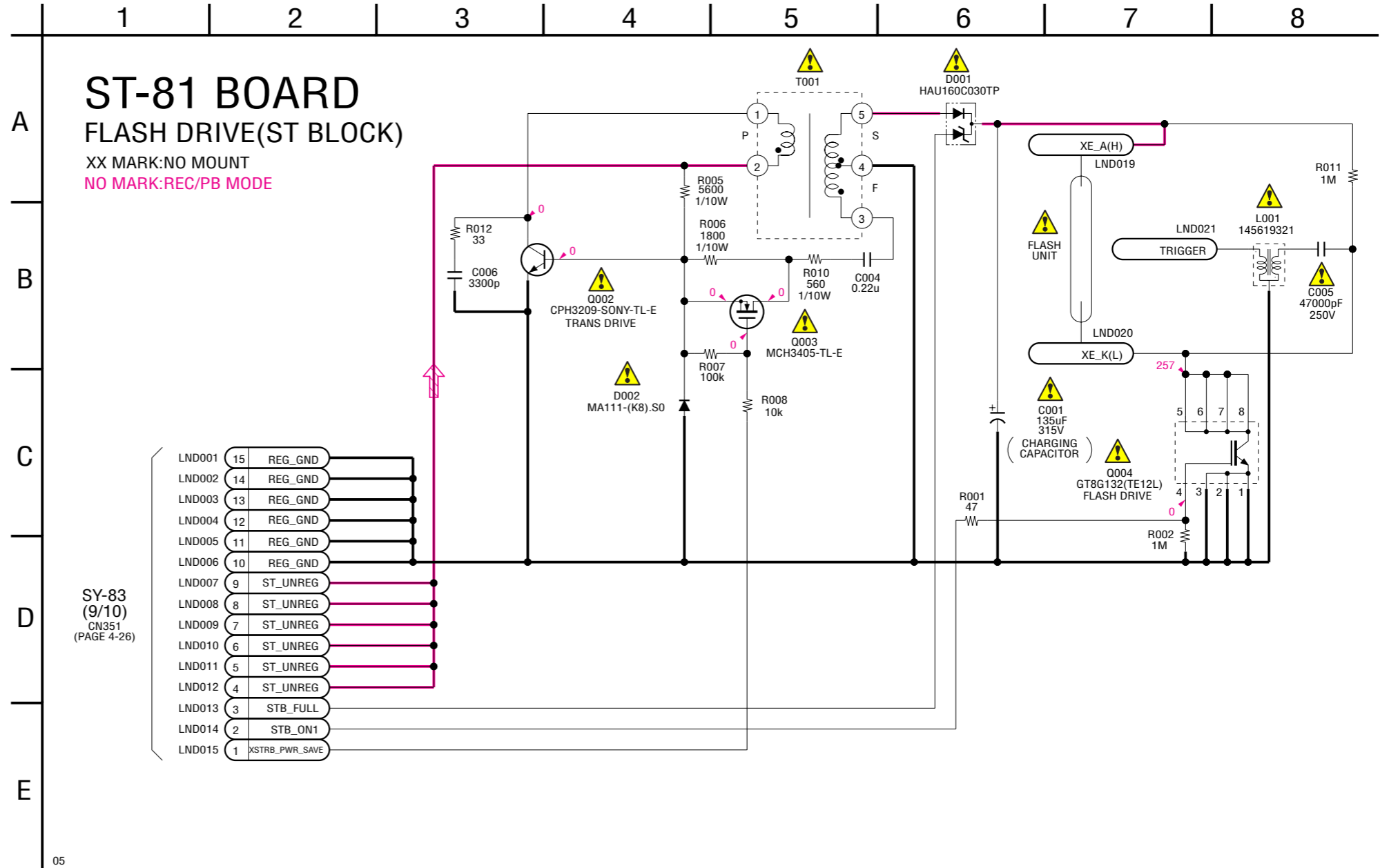

The components identified by mark \triangle or dotted line with mark \triangle are critical for safety. Replace only with part number specified.

Les composants identifiés par une marque \triangle sont critiques pour la sécurité. Ne les remplacer que par une pièce portant le numéro spécifié.

Schematic diagrams of the JK-243 and JK-244 board
are not shown.
Pages from 4-35 to 4-36 are not shown.



For Schematic Diagram
 • Refer to page 4-53 for printed wiring board.

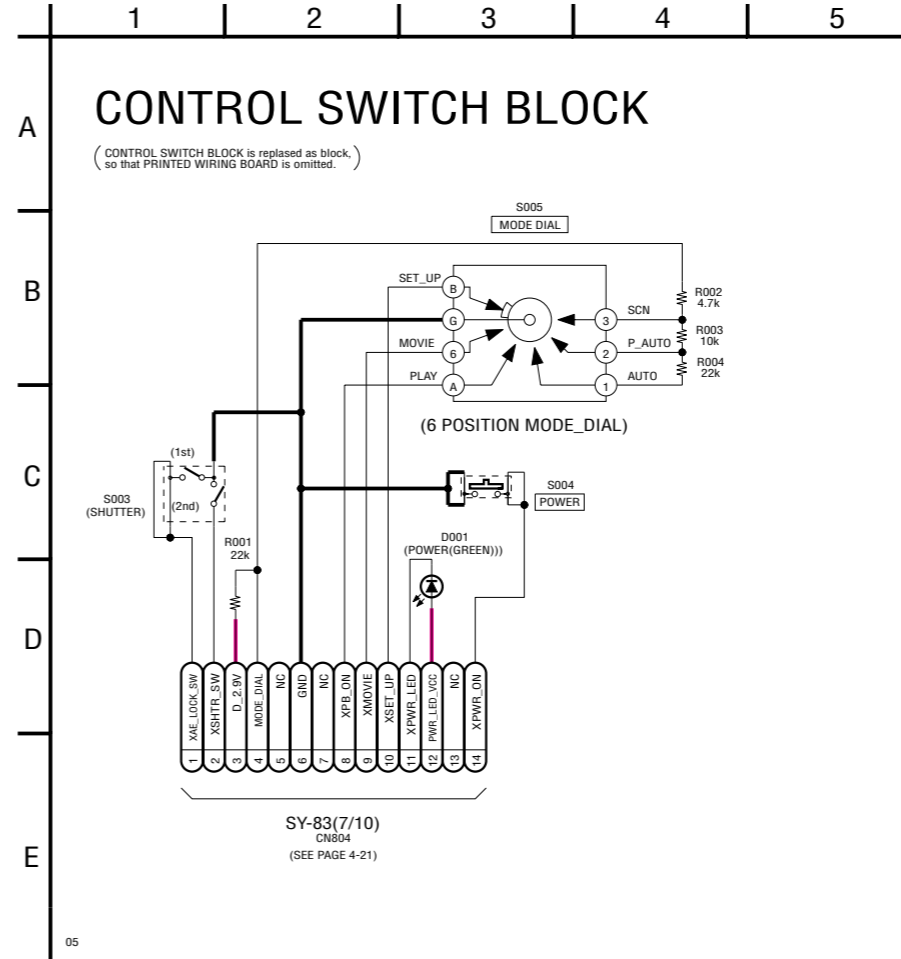
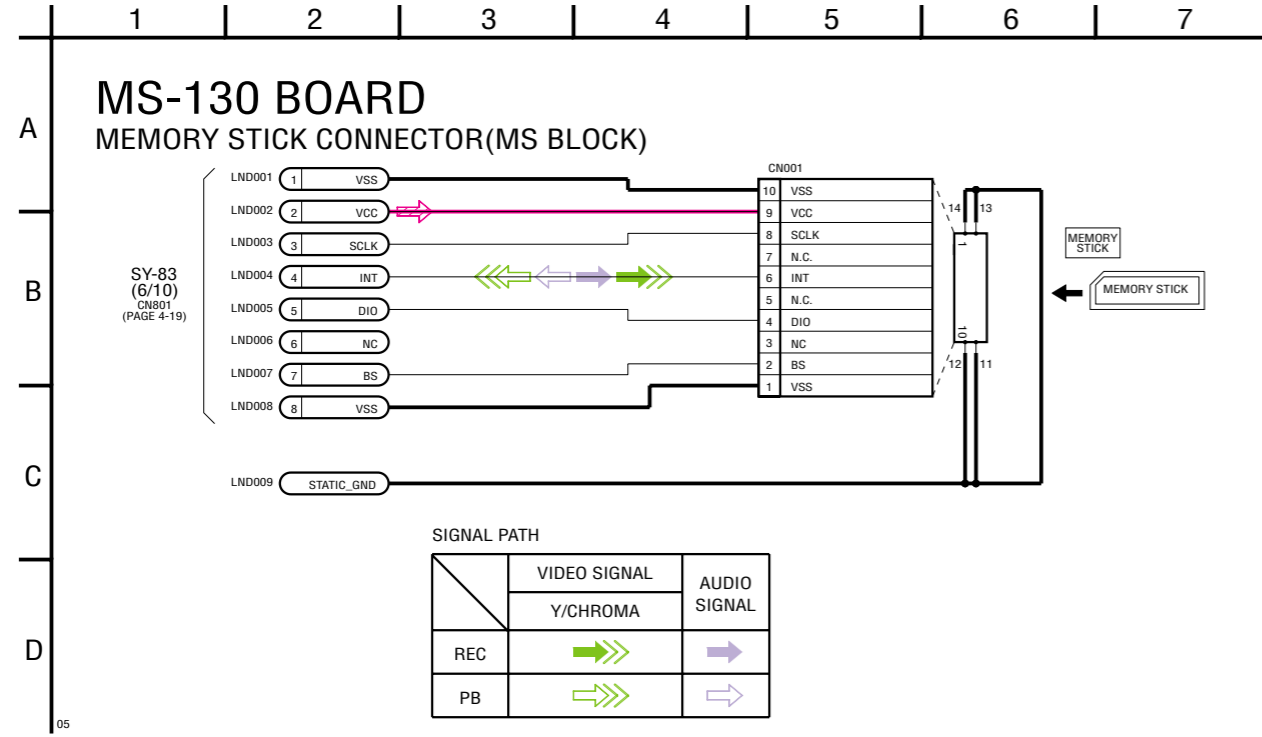



4-3. PRINTED WIRING BOARDS

4-3. PRINTED WIRING BOARDS

THIS NOTE IS COMMON FOR PRINTED WIRING BOARDS

- : Uses unleaded solder.
- : Circuit board
- : Flexible board
- : Pattern from the side which enables seeing. (The other layers' patterns are not indicated)
- : pattern of the rear side (The other layers' patterns are not indicated)
- Through hole is omitted.
- Circled numbers refer to waveforms.
- There are a few cases that the part printed on diagram isn't mounted in this model.
- : panel designation

- Chip parts.
Transistor

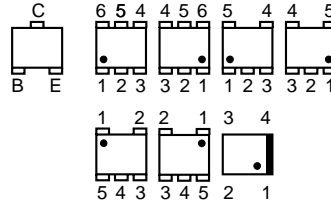

- Diode

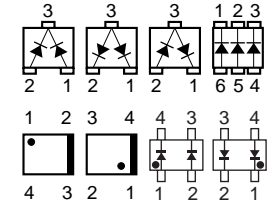

Board Name	Parts Location	Waveforms	Pattern	
			Total Number of Layers	Layers Not Indicated
CD-434	4-57	-	2 layers	-
SW-386	4-60	4-56	2 layers	-
ST-81	4-60	-	2 layers	-
MS-130	-	-	1 layers	-



4-3. PRINTED WIRING BOARDS

Link

• [CD-434 BOARD](#)

• [ST-81 BOARD](#)

• [SW-386 BOARD](#)

• [MS-130 BOARD](#)

• [COMMON NOTE FOR PRINTED WIRING BOARDS](#)

• [WAVEFORMS](#)

• [MOUNTED PARTS LOCATION](#)

• [CIRCUIT BOARDS LOCATION](#)



4-2. SCHEMATIC DIAGRAMS

4-3. PRINTED WIRING BOARDS

MOUNTED PARTS LOCATION

CD-434 (CCD IMAGER)

Note for Printed Wiring Board (See page 4-39).

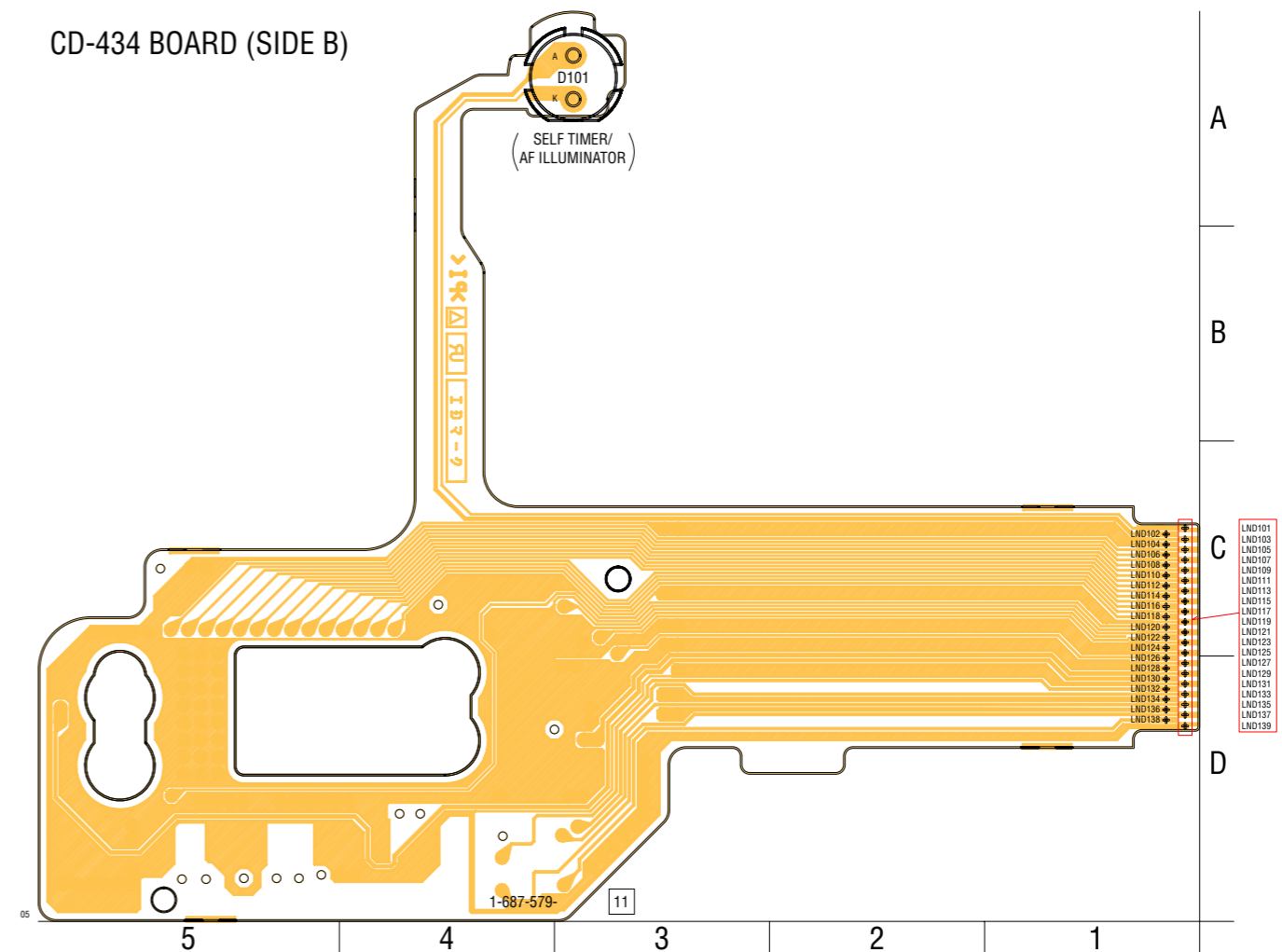
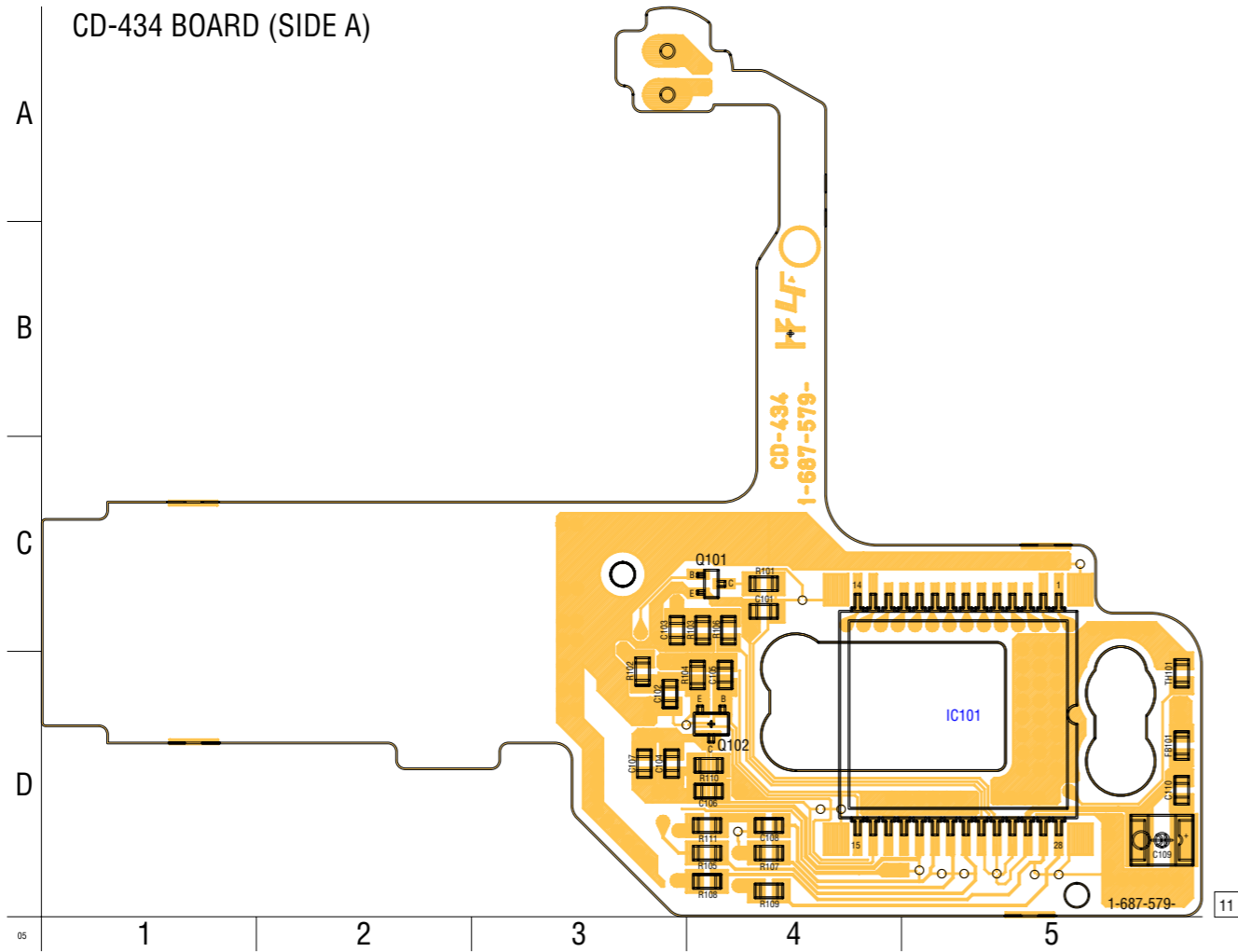

Printed wiring board of the SY-83 board are not shown.
Pages from 4-43 to 4-46 are not shown.



SW-386 (LCD DRIVE, TIMING GENERATOR, CONTROL SWITCH)

Note for Printed Wiring Board (See page 4-39).

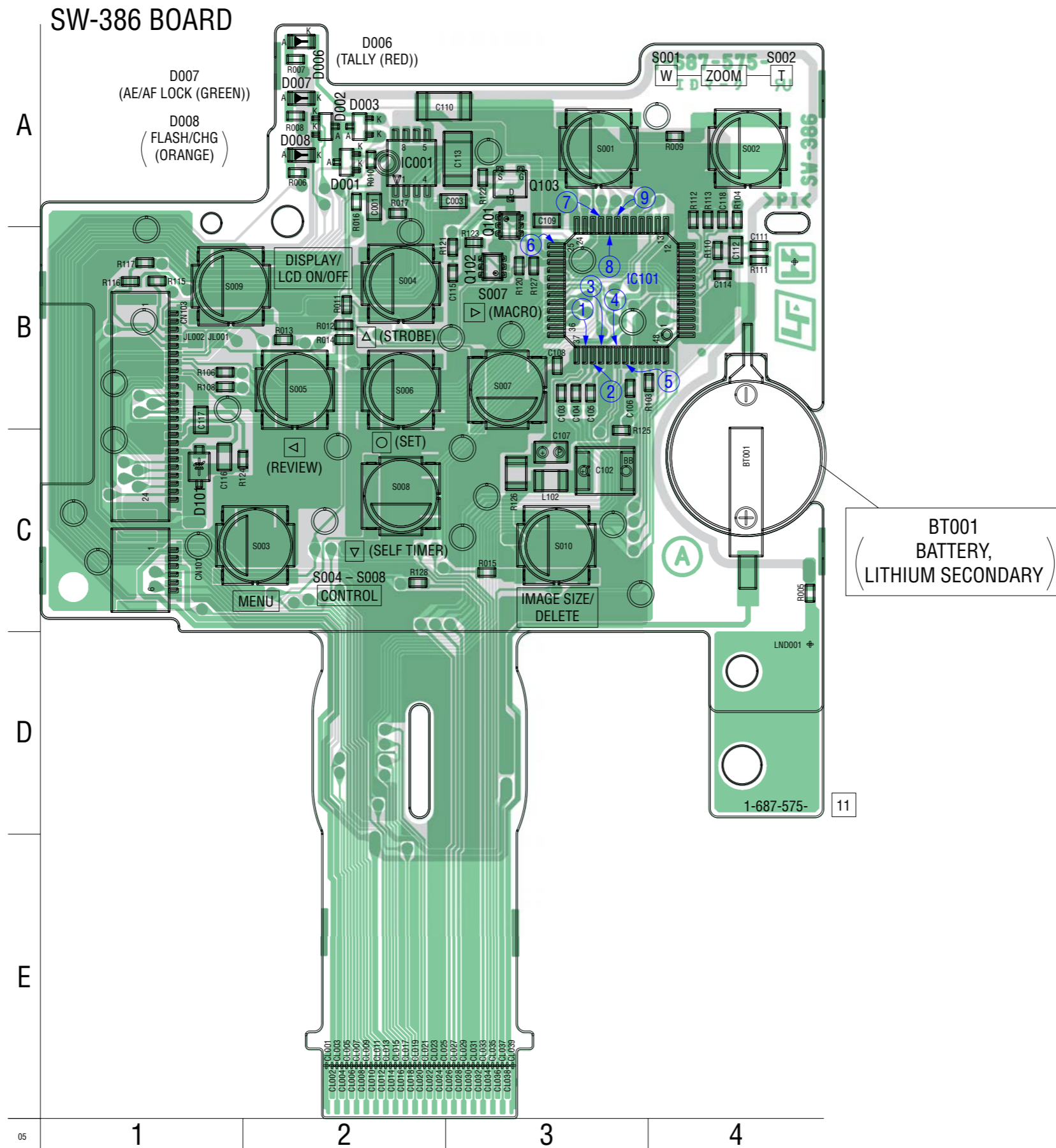



ST-81 (FLASH DRIVE)

Note for Printed Wiring Board (See page 4-39).

ST-81 BOARD (SIDE A)

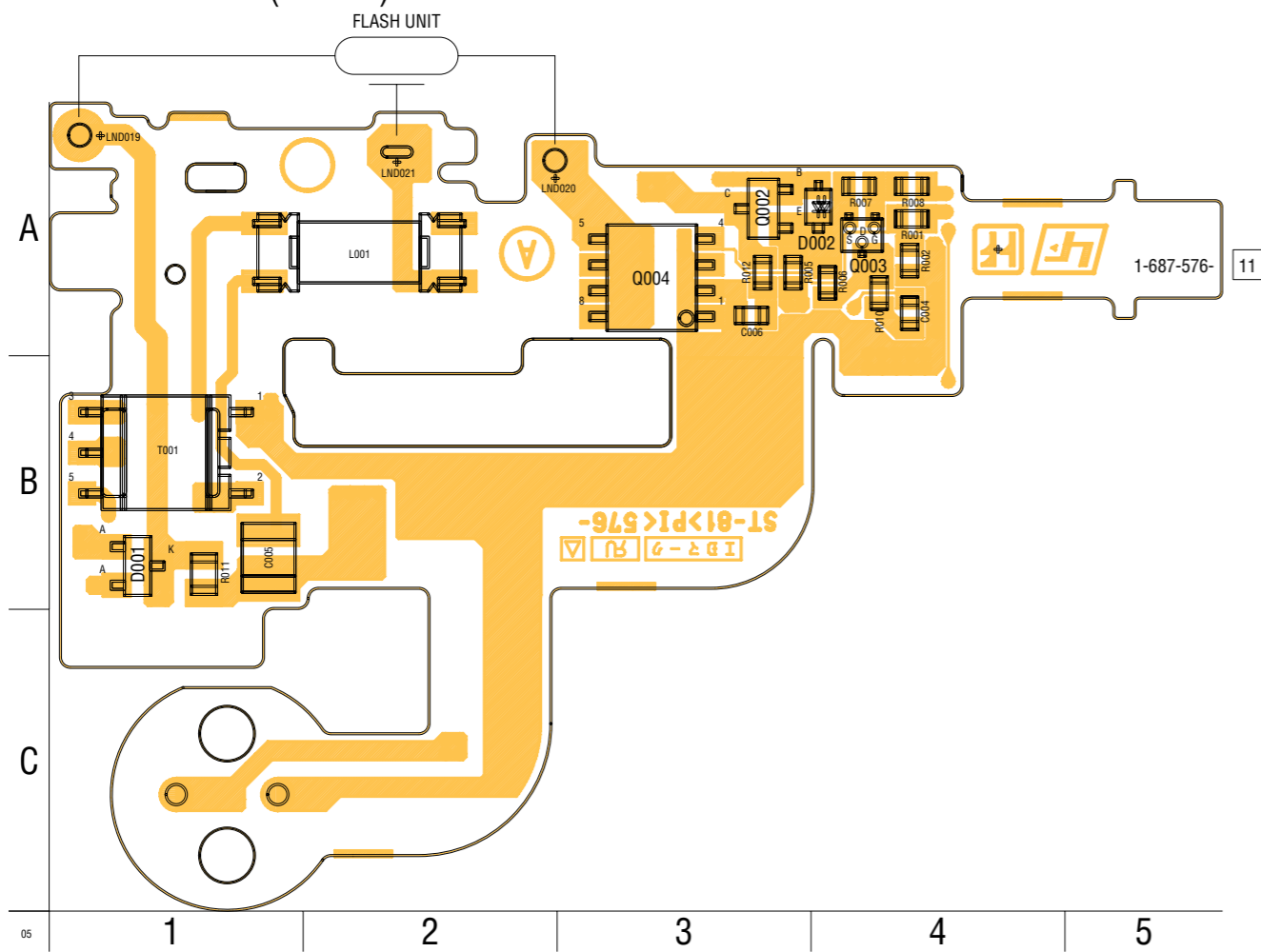

ST-81 BOARD (SIDE B)

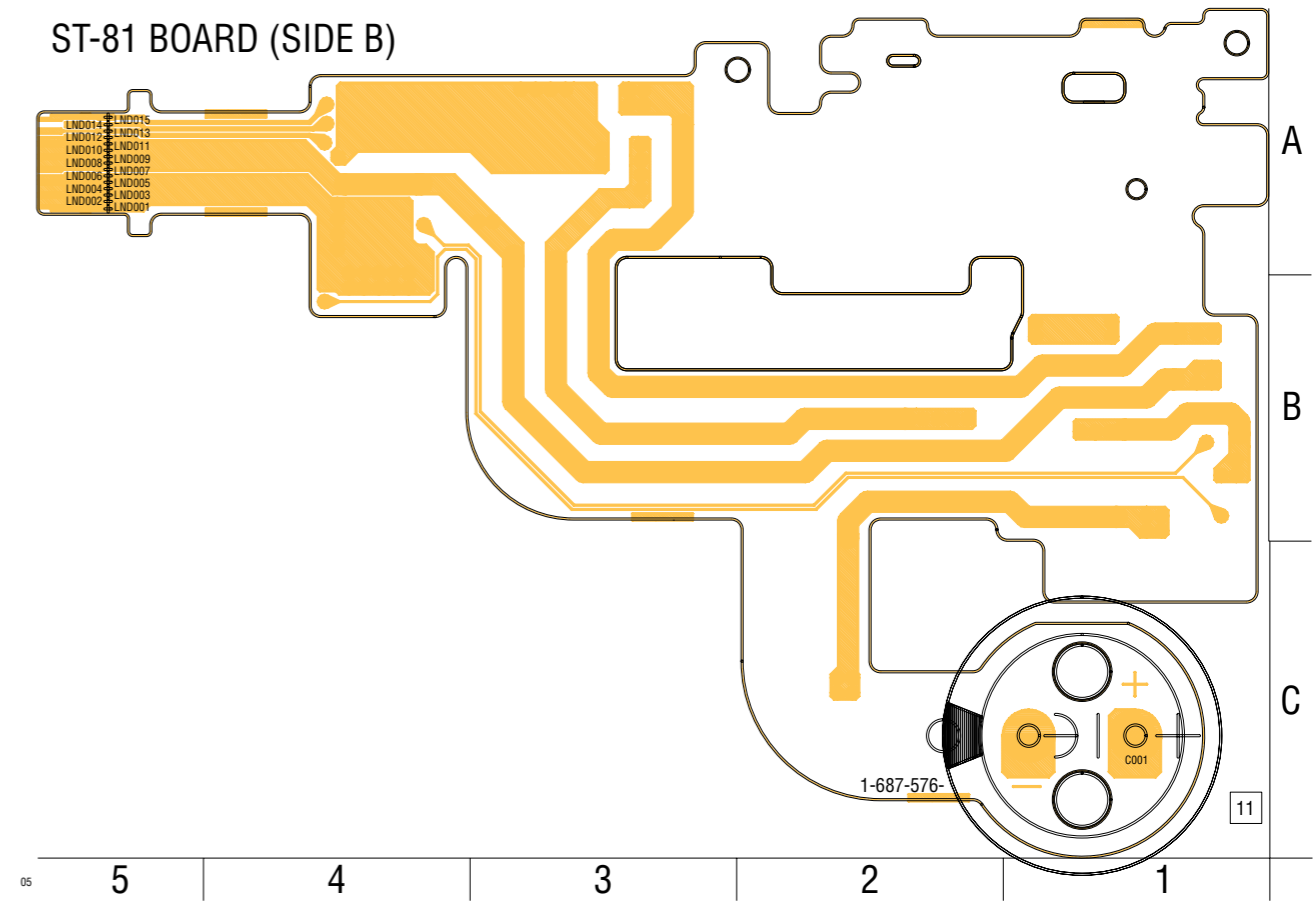

Printed wiring board of the JK-243 and JK-244 board
are not shown.
Pages from 4-51 to 4-52 are not shown.



MS-130 (MEMORY STICK CONNECTOR)

Note for Printed Wiring Board (See page 4-39).

MS-130 BOARD

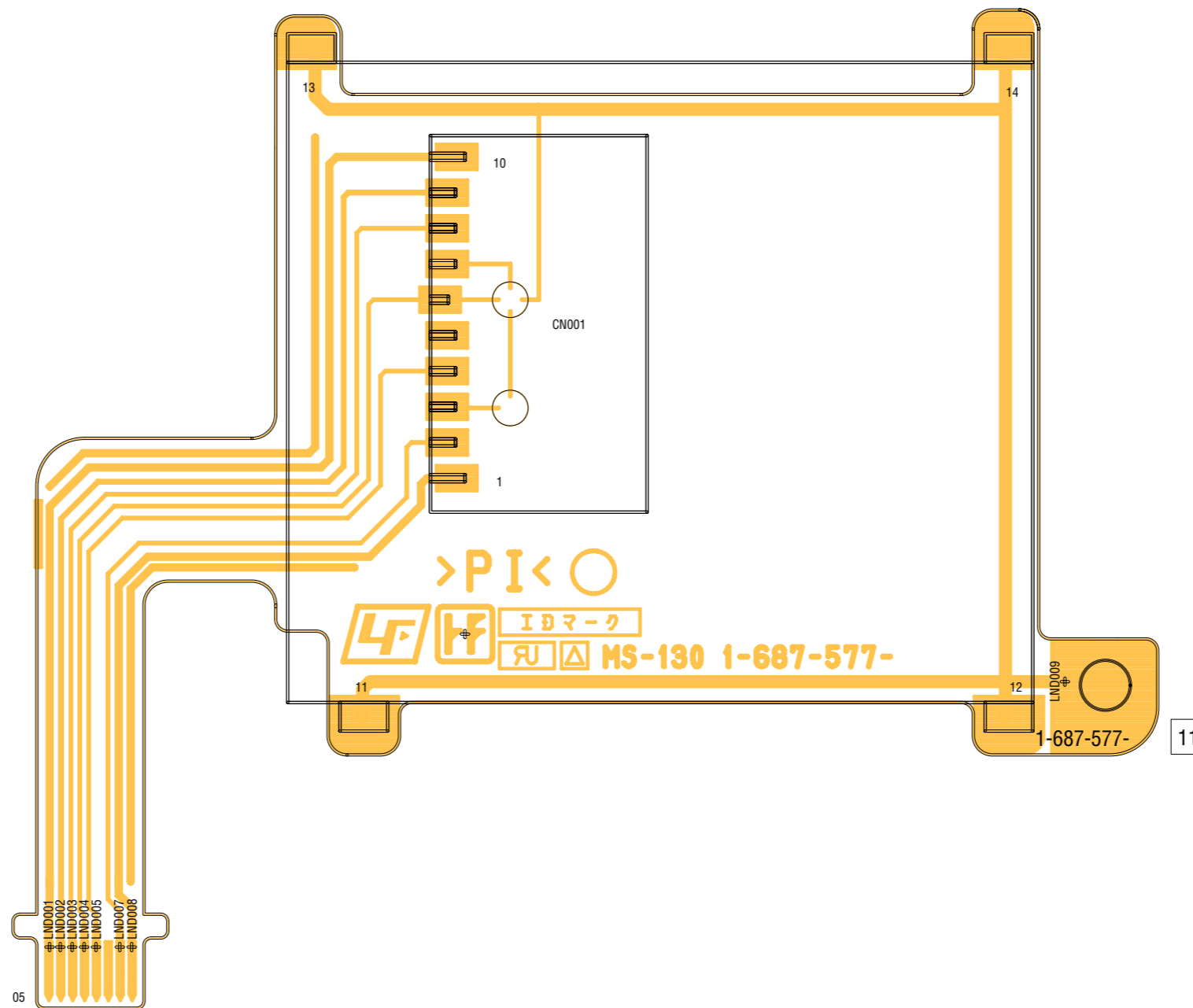

Waveforms of the SY-83 board are not shown.
Page 4-55 is not shown.



4-4. WAVEFORMS

SW-386 BOARD

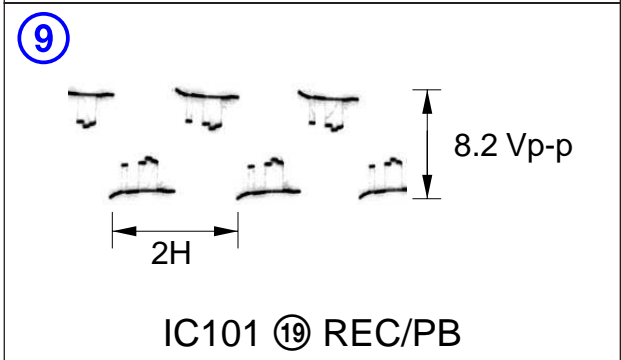
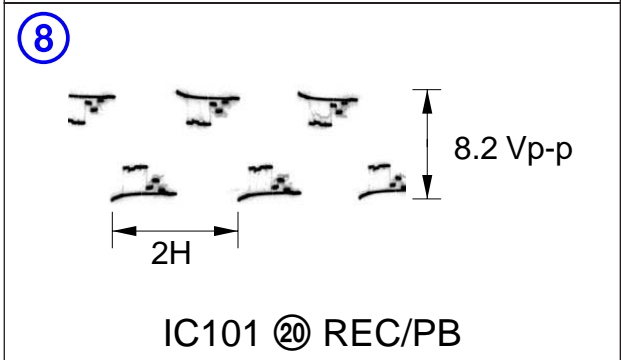
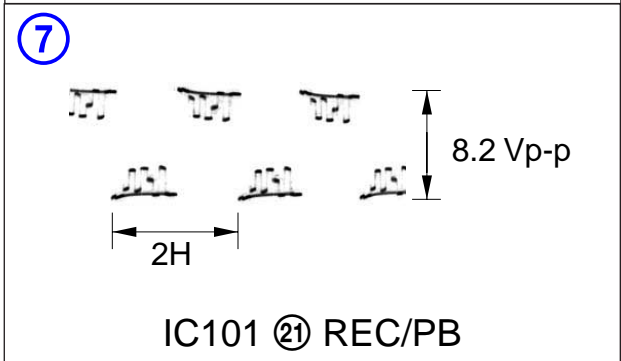
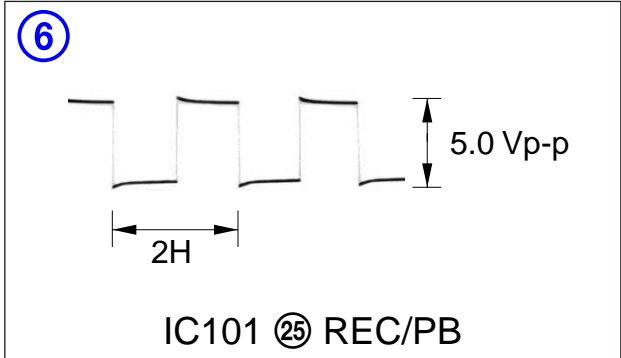
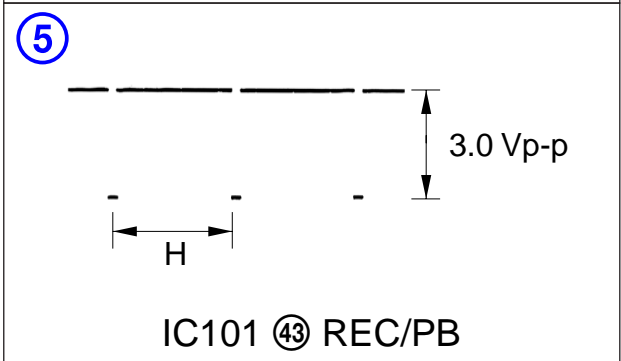
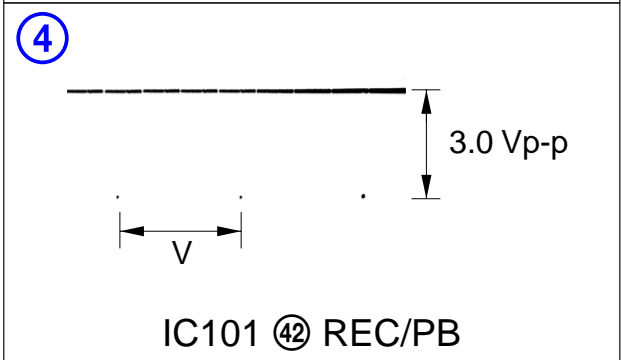
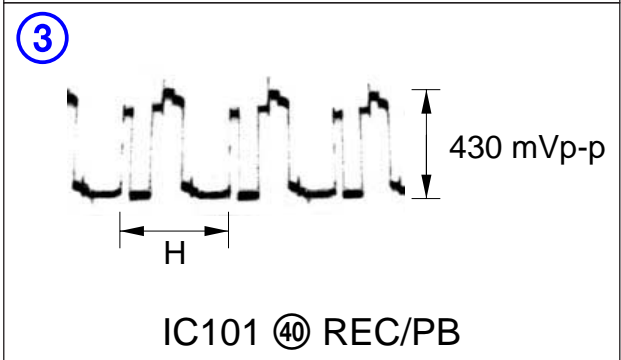
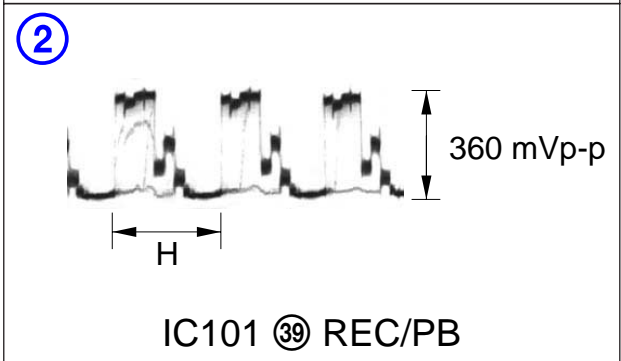
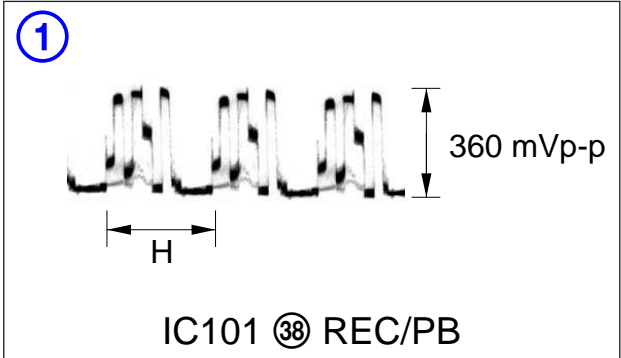

**4-3. PRINTED WIRING BOARDS****4-5. MOUNTED PARTS LOCATION**

no mark : side A
* mark : side B

CD-434 BOARD

C101	C-4
C103	C-3
C104	D-3
C107	D-3
C108	D-4
C109	D-5
*D101	A-3
FB101	D-5
IC101	D-5
Q101	C-4
Q102	D-4
R101	C-4
R102	D-3
R103	C-4
R104	D-4
R105	D-4
R106	C-4
R107	D-4
R108	D-4
R109	D-4
R110	D-4
R111	D-4
TH101	D-5

Mounted parts location of the SY-83 board are not shown.
Page 4-58 is not shown.



4-3. PRINTED WIRING BOARDS

no mark : side A
 * mark : side B

SW-386 BOARD

BT001 C-4
 C001 B-2
 C003 D-3
 C102 C-3
 C103 B-3
 C104 B-3
 C105 B-3
 C106 B-3
 C108 B-3
 C109 B-3
 C110 A-2
 C111 B-4
 C112 B-4
 C113 A-2
 C114 B-4
 C115 B-3
 C116 C-1
 C117 C-1
 C118 B-4
 CN101 C-1
 CN103 B-1
 D006 A-2
 D007 A-2
 D008 A-2
 D101 C-1
 IC001 A-2
 IC101 B-3
 L102 C-3
 Q101 B-3
 Q102 B-3
 Q103 A-3
 R006 A-2
 R007 A-2
 R008 A-2
 R009 A-4
 R010 A-2
 R011 B-2
 R012 B-2
 R013 B-2
 R014 B-2
 R015 C-3
 R016 A-2
 R017 A-2
 R103 B-3
 R104 B-4
 R106 B-2
 R108 B-2
 R111 B-4
 R112 B-4
 R113 B-4
 R115 B-1
 R116 B-1
 R117 B-1
 R120 B-3
 R121 B-3
 R122 A-3
 R123 B-3
 R124 C-2
 R125 C-3
 R126 C-3
 S001 A-3
 S002 A-4
 S003 C-2
 S004 B-2
 S005 B-2
 S006 B-2
 S007 B-3
 S008 C-2
 S009 B-1
 S010 C-3

ST-81 BOARD

* C001 C-1
 C004 A-4
 C005 B-1
 C006 A-3
 D001 B-1
 D002 A-4
 L001 A-2
 Q002 A-3
 Q003 A-4
 Q004 A-3
 R001 A-4
 R002 A-4
 R005 A-3
 R006 A-4
 R007 A-4
 R008 A-4
 R010 A-4
 R011 B-1
 R012 A-3
 T001 B-1

Mounted parts location of the JK-243 board are not shown.
Page 4-60 is not shown.



5. REPAIR PARTS LIST

NOTE: Characters **A** to **C** of the electrical parts list indicate location of exploded views in which the desired part is shown.

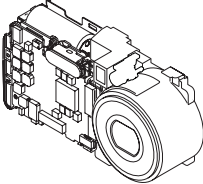
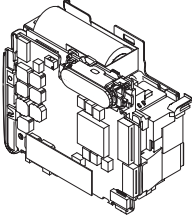
Link	EXPLODED VIEWS		
			
A	B	C	
CABINET SECTION	LENS SECTION	BATTERY HOLDER SECTION	

Link	ELECTRICAL PARTS LIST		ACCESSORIES	
• CD-434 BOARD	B	• ST-81 BOARD	C	
• MS-130 BOARD	C	• SW-386 BOARD	C	



5. REPAIR PARTS LIST

SECTION 5 REPAIR PARTS LIST

NOTE:

- -XX, -X mean standardized parts, so they may have some differences from the original one.
- Items marked "*" are not stocked since they are seldom required for routine service. Some delay should be anticipated when ordering these items.
- The mechanical parts with no reference number in the exploded views are not supplied.
- Due to standardization, replacements in the parts list may be different from the parts specified in the diagrams or the components used on the set.
- CAPACITORS:
uF: μ F
- COILS
uH: μ H
- RESISTORS
All resistors are in ohms.
METAL: metal-film resistor
METAL OXIDE: Metal Oxide-film resistor
F: nonflammable
- SEMICONDUCTORS
In each case, u: μ , for example:
uA...: μ A..., uPA..., μ PA...,
uPB..., μ PB..., uPC..., μ PC...,
uPD..., μ PD...
- Abbreviation
AUS : Australian model
CH : Chinese model
CND : Canadian model
J : Japanese model
JE : Tourist model
HK : Hong Kong model
KR : Korean model
- No deep blue models are made as US or Canadian models.

When indicating parts by reference number, please include the board name.

The components identified by mark \triangle or dotted line with mark \triangle are critical for safety. Replace only with part number specified.

Les composants identifiés par une marque \triangle sont critiques pour la sécurité. Ne les remplacer que par une pièce portant le numéro spécifié.



5. REPAIR PARTS LIST

5-1. EXPLODED VIEWS

5-1-1. CABINET SECTION

ns: not supplied

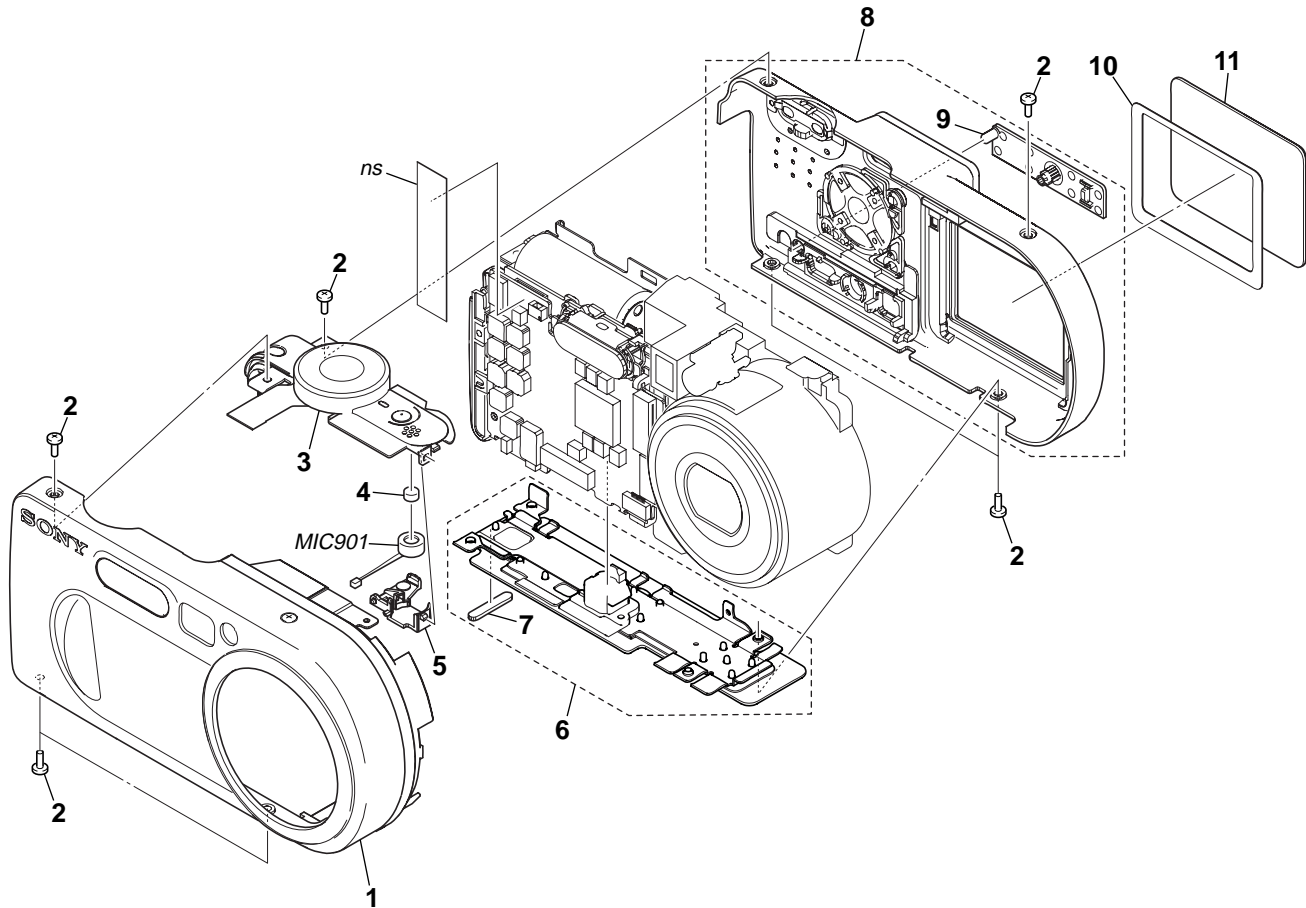

Ref. No.	Part No.	Description	Remark	Ref. No.	Part No.	Description	Remark
1	X-3953-292-1	CABINET FRONT ASSY (SILVER)		7	3-081-764-01	FOOT, RUBBER	
1	X-3953-441-1	CABINET FRONT ASSY (DEEP BLUE)		8	X-3953-269-2	CABINET (REAR) (A) ASSY (P10: SILVER)	
2	3-080-198-11	SCREW (M1.7), LOCK ACE, P2 (DEEP BLUE)		8	X-3953-503-1	CABINET (REAR) (A) ASSY (P12)	
2	4-974-725-01	SCREW (M1.7), LOCK ACE, P2 (SILVER)		8	X-3953-502-1	CABINET (REAR) ASSY (P10: DEEP BLUE)	
3	1-477-771-11	SWITCH BLOCK, CONTROL (SILVER)		9	3-081-742-31	COVER, JACK (SILVER)	
3	1-477-771-21	SWITCH BLOCK, CONTROL (DEEP BLUE)		9	3-081-742-41	COVER, JACK (DEEP BLUE)	
4	3-081-763-01	CUSHION, MICROPHONE		10	3-081-761-01	SHEET, ADHESIVE, LCD WINDOW	
5	3-081-747-01	CASE, MICROPHONE		11	3-081-762-01	WINDOW, LCD	
6	X-3953-264-1	CABINET (LOWER) ASSY (SILVER)		MIC901	1-542-519-11	MICROPHONE	
6	X-3953-456-1	CABINET (LOWER) ASSY (DEEP BLUE)					



5. REPAIR PARTS LIST

5-1-2. LENS SECTION

ns: not supplied

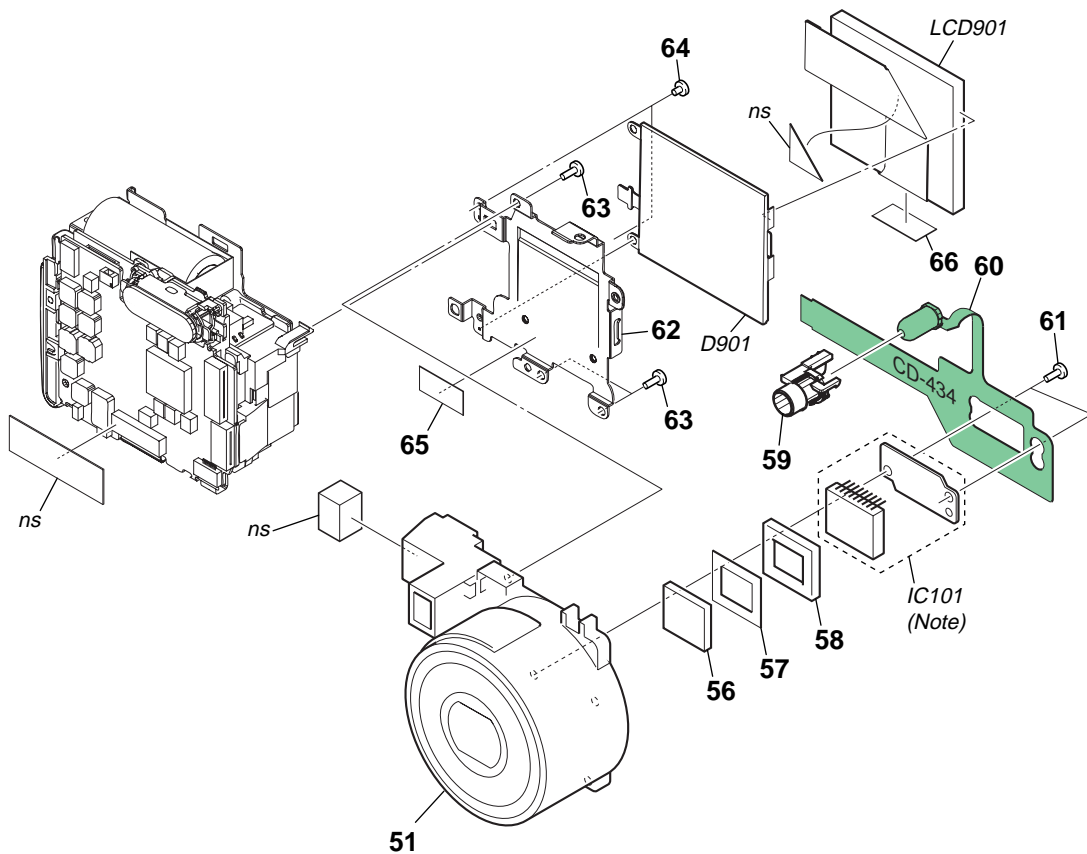

(Note) Be sure to read "Precautions for Replacement of CCD Imager" on page 4-8 when changing the CCD imager.

The components identified by mark Δ or dotted line with mark Δ are critical for safety. Replace only with part number specified.	Les composants identifiés par une marque Δ sont critiques pour la sécurité. Ne les remplacer que par une pièce portant le numéro spécifié.
--	---

Ref. No.	Part No.	Description	Remark	Ref. No.	Part No.	Description	Remark
51	1-758-913-11	LENS, VIDEO (CE01C)		63	3-080-204-11	SCREW, TAPPING, P2	
56	1-758-915-11	FILTER BLOCK, OPTICAL		64	3-081-427-01	SPECIAL	
57	3-070-143-01	PLATE, LIGHT INTERCEPTION		65	3-081-766-01	SHEEY, INSULATING, SY	
58	3-054-555-01	RUBBER (K), SEAL		66	CAUTION TAPE (K)		
59	3-081-681-01	HOLDER, AF		Δ D901	1-477-429-21	BLOCK, LIGHT GUIDE PLATE	
60	A-7078-634-A	CD-434 BOARD, COMPLETE		IC101	A-7016-178-A	CCD BLOCK ASSY	
61	3-078-890-21	SCREW, TAPPING		LCD901	8-753-052-52	ACX309AKC-1	
62	3-081-745-01	LENS FRAME					

CAUTION :
 For the part of 66 : TAPE (K) (3-075-828-01), cut WOVEN (T0.25), FABRIC NON (3-076-631-01) into the desired length and use it.



5. REPAIR PARTS LIST

5-1-3. BATTERY HOLDER SECTION

ns: not supplied

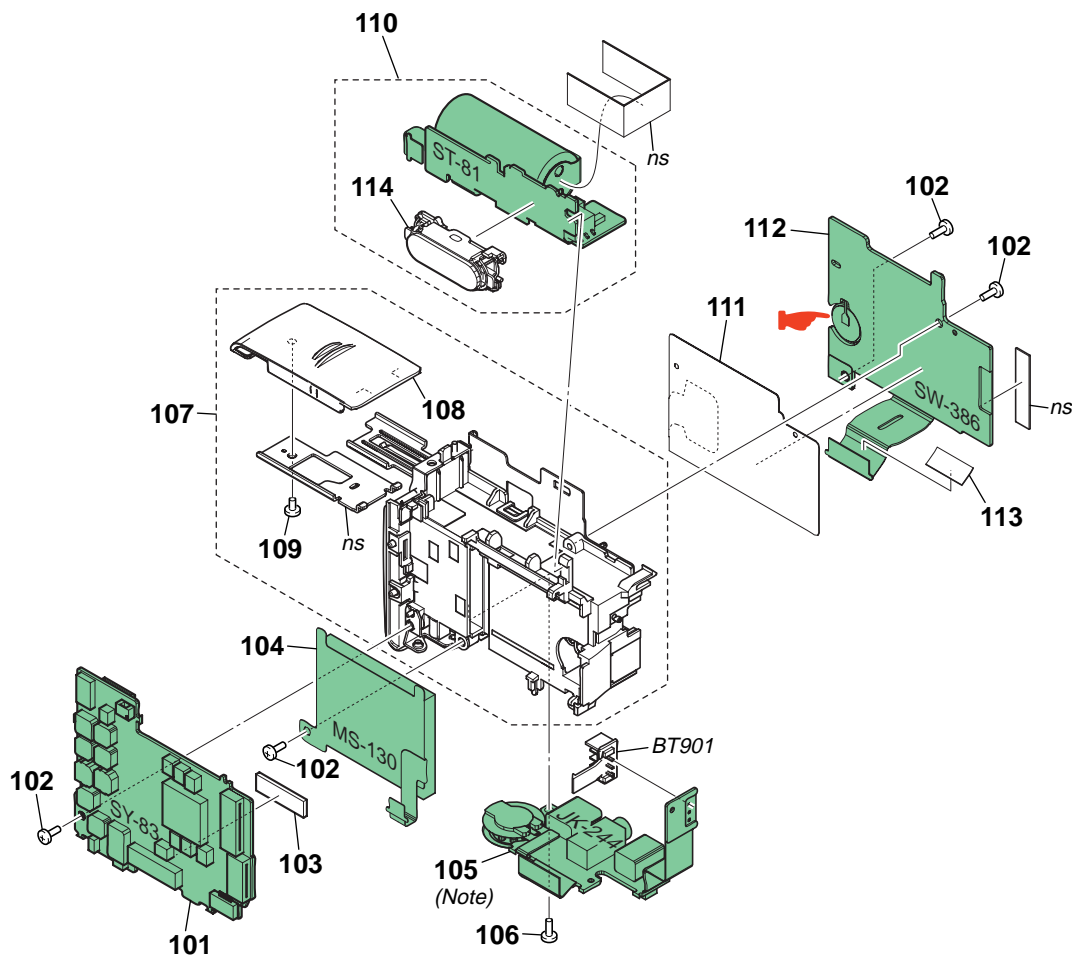

: BT001 (BATTERY, LITHIUM SECONDARY)
Board on the mount position. (See page 4-48.)

(Note) Including the parts mounted on JK-243 board.

The components identified by mark Δ or dotted line with mark Δ are critical for safety. Replace only with part number specified.	Les composants identifiés par une marque Δ sont critiques pour la sécurité. Ne les remplacer que par une pièce portant le numéro spécifié.
--	---

Ref. No.	Part No.	Description	Remark	Ref. No.	Part No.	Description	Remark
101	A-7078-690-A	SY-83 BOARD, COMPLETE (SERVICE)		108	3-081-637-42	LID, BT (DEEP BLUE)	
102	3-080-204-11	SCREW, TAPPING, P2		109	3-318-382-01	SCREW (1.7X3), TAPPING	
103	3-081-765-01	SHEET, SY RETAINER		110	A-7078-618-A	ST-81 BOARD, COMPLETE	
104	A-7078-620-A	MS-130 BOARD, COMPLETE		111	3-081-748-02	SHEET (LI), INSLATING	
105	A-7078-616-A	JK-244 BOARD, COMPLETE		112	A-7078-615-A	SW-386 BOARD, COMPLETE	
106	4-974-725-01	SCREW (M1.7), LOCK ACE, P2		113	3-084-050-01	TAPE SW	
107	X-3953-293-2	HOLDER ASSY, BATTERY (SILVER)		Δ 114	1-477-769-11	STROBO LUMINESCENCE UNIT	
107	X-3953-294-2	HOLDER ASSY, BATTERY (DEEP BLUE)		BT901	1-694-854-11	BATTERY TERMINAL BOARD	
108	3-081-637-32	LID, BT (SILVER)					

5-2. ELECTRICAL PARTS LIST

Ref. No.	Part No.	Description
	A-7078-634-A	CD-434 BOARD, COMPLETE ***** (IC101 is not included in this board)
< CAPACITOR >		
C101	1-107-826-11	CERAMIC CHIP 0.1uF 10% 16V
C103	1-162-966-11	CERAMIC CHIP 0.0022uF 10% 50V
C104	1-107-826-11	CERAMIC CHIP 0.1uF 10% 16V
C107	1-107-826-11	CERAMIC CHIP 0.1uF 10% 16V
C108	1-107-826-11	CERAMIC CHIP 0.1uF 10% 16V
C109	1-135-957-91	TANTAL. CHIP 10uF 20% 16V
C110	1-107-826-11	CERAMIC CHIP 0.1uF 10% 16V
< DIODE >		
D101	6-500-398-01	DIODE OPR5052 (SELF TIMER/AF ILLUMINATOR)
< FERRITE BEAD >		
FB101	1-414-228-11	FERRITE 0uH
< IC >		
IC101	A-7016-178-A	CCD BLOCK ASSY (CCD IMAGER) (Note)
< TRANSISTOR >		
Q101	8-729-037-74	TRANSISTOR UN9213J- (TK).SO
Q102	8-729-050-22	TRANSISTOR 2SC4250 (T5LSONY1)
< RESISTOR >		
R101	1-216-823-11	METAL CHIP 1.5K 5% 1/10W
R102	1-216-864-11	METAL CHIP 0 5% 1/10W
R103	1-216-857-11	METAL CHIP 1M 5% 1/10W
R104	1-216-827-11	METAL CHIP 3.3K 5% 1/10W
R105	1-216-864-11	METAL CHIP 0 5% 1/10W
R106	1-216-864-11	METAL CHIP 0 5% 1/10W
R107	1-216-864-11	METAL CHIP 0 5% 1/10W
R108	1-216-864-11	METAL CHIP 0 5% 1/10W
R109	1-216-864-11	METAL CHIP 0 5% 1/10W
R110	1-216-819-11	METAL CHIP 680 5% 1/10W
R111	1-216-864-11	METAL CHIP 0 5% 1/10W
< THERMISTOR >		
TH101	1-810-816-11	THERMISTOR, NTC (1608)

Electrical parts list of the JK-244 board is not shown.
Page 5-6 is not shown.

(Note) Be sure to read "Precautions for Replacement of CCD Imager" on page 4-8 when changing the CCD imager.

MS-130

ST-81

SW-386

Ref. No.	Part No.	Description
	A-7078-620-A	MS-130 BOARD, COMPLETE *****
		< CONNECTOR >
CN001	1-815-572-61	CONNECTOR, MEMORY STICK
	A-7078-618-A	ST-81 BOARD, COMPLETE *****
△	1-477-769-11	STROBO LUMINESCENCE UNIT < CAPACITOR >
△ C001	1-100-528-11	ELECT 135uF 315V
C004	1-127-715-91	CERAMIC CHIP 0.22uF 10% 16V
△ C005	1-137-723-21	CERAMIC CHIP 0.047uF 10% 250V
C006	1-162-967-11	CERAMIC CHIP 0.0033uF 10% 50V
		< DIODE >
△ D001	6-500-237-01	DIODE HAU160C030TP
△ D002	8-719-073-01	DIODE MA111- (K8).S0
		< COIL >
△ L001	1-456-193-11	COIL, TRIGGER < TRANSISTOR >
△ Q002	6-550-183-01	TRANSISTOR CPH3209-SONY-TL-E
△ Q003	8-729-056-01	TRANSISTOR MCH3405-TL-E
△ Q004	8-729-053-74	TRANSISTOR CY25AAJ-8-T13
		< RESISTOR >
R001	1-216-805-11	METAL CHIP 47 5% 1/10W
R002	1-216-857-11	METAL CHIP 1M 5% 1/10W
R005	1-216-830-11	METAL CHIP 5.6K 5% 1/10W
R006	1-216-824-11	METAL CHIP 1.8K 5% 1/10W
R007	1-216-845-11	METAL CHIP 100K 5% 1/10W
R008	1-216-833-11	METAL CHIP 10K 5% 1/10W
R010	1-216-818-11	METAL CHIP 560 5% 1/10W
R011	1-216-121-11	RES-CHIP 1M 5% 1/10W
R012	1-216-803-11	METAL CHIP 33 5% 1/10W
		< TRANSFORMER >
△ T001	1-439-714-21	DC-DC CONVERTER TRANSFORMER
	A-7078-615-A	SW-386 BOARD, COMPLETE *****
		< BATTERY >
△ BT001	1-756-348-11	BATTERY, LITHIUM (SECONDARY) < CAPACITOR >
C001	1-107-826-11	CERAMIC CHIP 0.1uF 10% 16V
C003	1-107-826-11	CERAMIC CHIP 0.1uF 10% 16V
C102	1-125-839-91	TANTAL. CHIP 47uF 20% 6.3V
C103	1-164-943-11	CERAMIC CHIP 0.01uF 10% 16V
C104	1-164-943-11	CERAMIC CHIP 0.01uF 10% 16V
C105	1-164-943-11	CERAMIC CHIP 0.01uF 10% 16V

Ref. No.	Part No.	Description
C106	1-125-777-11	CERAMIC CHIP 0.1uF 10% 10V
C108	1-125-777-11	CERAMIC CHIP 0.1uF 10% 10V
C109	1-107-826-11	CERAMIC CHIP 0.1uF 10% 16V
C110	1-127-820-11	CERAMIC CHIP 4.7uF 16V
C111	1-125-777-11	CERAMIC CHIP 0.1uF 10% 10V
C112	1-164-739-11	CERAMIC CHIP 560PF 5% 50V
C113	1-115-566-11	CERAMIC CHIP 4.7uF 10% 10V
C114	1-125-777-11	CERAMIC CHIP 0.1uF 10% 10V
C115	1-164-943-11	CERAMIC CHIP 0.01uF 10% 16V
C116	1-165-908-91	CERAMIC CHIP 1uF 10% 10V
C117	1-107-826-11	CERAMIC CHIP 0.1uF 10% 16V
C118	1-164-939-11	CERAMIC CHIP 0.0022uF 10% 50V
		< CONNECTOR >
CN101	1-794-766-21	CONNECTOR, FFC/FPC (LIF) 6P
CN103	1-794-770-11	CONNECTOR, FFC/FPC (LIF) 24P
		< DIODE >
D006	8-719-077-09	DIODE CL-196HR-CD-T (TALLY (RED))
D007	8-719-063-83	DIODE SML-510MWT86 (AE/AF LOCK (GREEN))
D008	8-719-077-34	DIODE SML-310YTT86 (FLASH/CHG (ORANGE))
D101	8-719-017-82	DIODE MA8036
		< IC >
IC001	6-700-712-01	IC NJM2370RD5 (TE2)
IC101	8-752-109-23	IC CXA3622R-T4
		< COIL >
L102	1-469-757-21	INDUCTOR 10uH
		< TRANSISTOR >
Q101	8-759-054-48	TRANSISTOR C010-PW2000SV-V110
Q102	8-759-054-48	TRANSISTOR C010-PW2000SV-V110
Q103	8-729-056-00	TRANSISTOR MCH3310-TL-E
		< RESISTOR >
R006	1-220-175-11	RES-CHIP 240 5% 1/16W
R007	1-208-690-11	RES-CHIP 2K 5% 1/16W
R008	1-218-947-11	RES-CHIP 330 5% 1/16W
R009	1-218-954-11	RES-CHIP 1.2K 5% 1/16W
R010	1-218-954-11	RES-CHIP 1.2K 5% 1/16W
R011	1-218-955-11	RES-CHIP 1.5K 5% 1/16W
R012	1-218-954-11	RES-CHIP 1.2K 5% 1/16W
R013	1-218-959-11	RES-CHIP 3.3K 5% 1/16W
R014	1-218-955-11	RES-CHIP 1.5K 5% 1/16W
R015	1-218-959-11	RES-CHIP 3.3K 5% 1/16W
R016	1-218-990-11	SHORT CHIP 0
R017	1-218-981-11	RES-CHIP 220K 5% 1/16W
R103	1-218-990-11	SHORT CHIP 0
R104	1-218-953-11	RES-CHIP 1K 5% 1/16W
R106	1-218-990-11	SHORT CHIP 0
R108	1-218-990-11	SHORT CHIP 0
R111	1-218-975-11	RES-CHIP 68K 5% 1/16W
R112	1-208-707-11	METAL CHIP 10K 0.5% 1/16W
R113	1-208-935-11	METAL CHIP 100K 0.5% 1/16W
R115	1-208-635-11	RES-CHIP 10 5% 1/16W

The components identified by mark △ or dotted line with mark △ are critical for safety. Replace only with part number specified.	Les composants identifiés par une marque △ sont critiques pour la sécurité. Ne les remplacer que par une pièce portant le numéro spécifié.
--	--

DSC-P10/P12

SW-386

<u>Ref. No.</u>	<u>Part No.</u>	<u>Description</u>			
R116	1-208-635-11	RES-CHIP	10	5%	1/16W
R117	1-208-635-11	RES-CHIP	10	5%	1/16W
R120	1-218-973-11	RES-CHIP	47K	5%	1/16W
R121	1-218-961-11	RES-CHIP	4.7K	5%	1/16W
R122	1-218-981-11	RES-CHIP	220K	5%	1/16W
R123	1-218-973-11	RES-CHIP	47K	5%	1/16W
R124	1-218-979-11	RES-CHIP	150K	5%	1/16W
R125	1-218-990-11	SHORT CHIP	0		
R126	1-216-295-91	SHORT CHIP	0		

< SWITCH >

S001	1-786-157-11	SWITCH, TACTILE (ZOOM SW (W))
S002	1-786-157-11	SWITCH, TACTILE (ZOOM SW (T))
S003	1-786-157-11	SWITCH, TACTILE (MENU)
S004	1-786-157-11	SWITCH, TACTILE (Δ (STROBE))
S005	1-786-157-11	SWITCH, TACTILE (< (REVIEW))
S006	1-786-157-11	SWITCH, TACTILE (○ (SET))
S007	1-786-157-11	SWITCH, TACTILE (▷ (MACRO))
S008	1-786-157-11	SWITCH, TACTILE (▽ SELFTIMER))
S009	1-786-157-11	SWITCH, TACTILE (DISPLAY/LCD ON/OFF)
S010	1-786-157-11	SWITCH, TACTILE (IMAGE SIZE/DELETE)

Electrical parts list of the SY-83 board is not shown.
Pages 5-9 to 5-13 are not shown.

Checking supplied accessories.

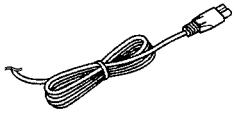

Power cord (1)
 ▲ 1-696-819-11 (AUS)
 ▲ 1-769-608-11 (AEP, E)
 ▲ 1-776-985-11 (KR)
 ▲ 1-782-476-13 (CH)
 ▲ 1-783-374-11 (UK, HK)
 ▲ 1-790-107-22 (US, CND)
 ▲ 1-790-732-11 (JE, J)

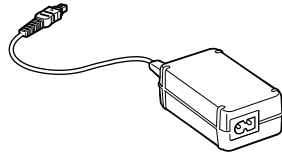

AC adaptor
 AC-LS5 (1)
 ▲ 1-477-730-11 (EXCEPT CH)
 ▲ 1-477-730-21 (CH)

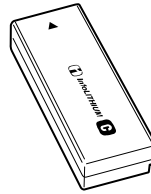

NP-FC11 battery pack
 (P10: 1, P12: 2)

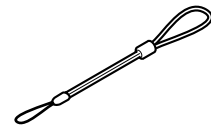

Wrist strap (1)
 3-050-664-11



USB cable (1)
 1-827-038-11

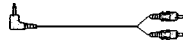

A/V connecting cable (1)
 1-824-111-11

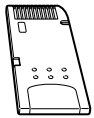

"Memory Stick" (32MB) (1)

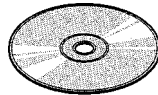

CD-ROM
 (SPVD-010 USB driver) (1)
 3-078-942-03 (EXCEPT US, CND, J)
 3-078-943-03 (US, CND, J)



Conversion Adaptor (1)
 ▲ 1-569-008-12 (E)



Conversion Adaptor (1)
 ▲ 1-569-007-11 (E, JE)

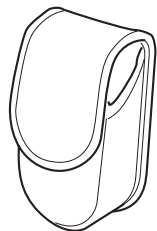

Soft carrying case (1)
 3-082-064-01 (P12)

Other accessories

- 3-080-892-01 MANUAL, INSTRUCTION (for BASIC) (JAPANESE) (J)
- 3-080-892-11 MANUAL, INSTRUCTION (ENGLISH)
 (US, CND, AEP, UK, E, AUS, CH, HK, JE)
- 3-080-892-21 MANUAL, INSTRUCTION (FRENCH, GERMAN)
 (CND, AEP)
- 3-080-892-31 MANUAL, INSTRUCTION (SPANISH, PORTUGUESE)
 (AEP, E, JE)
- 3-080-892-41 MANUAL, INSTRUCTION (ITALIAN, DUTCH) (AEP)
- 3-080-892-51 MANUAL, INSTRUCTION
 (TRADITIONAL CHINESE, SIMPLIFIED CHINESE)
 (E, CH, HK, JE)
- 3-080-892-61 MANUAL, INSTRUCTION (RUSSIAN, SWEDISH) (AEP)
- 3-080-892-71 MANUAL, INSTRUCTION (ARABIC) (E)
- 3-080-892-81 MANUAL, INSTRUCTION (KOREAN) (KR)
- 3-080-893-01 MANUAL, INSTRUCTION (for APPLICATION)
 (JAPANESE) (J)

The components identified by mark ▲ or dotted line with mark ▲ are critical for safety. Replace only with part number specified.

Les composants identifiés par une marque ▲ sont critiques pour la sécurité. Ne les remplacer que par une pièce portant le numéro spécifié.

Revision History

Ver.	Date	History	Contents	S.M. Rev. issued
1.0	2003.03	Official Release	—	—